



Analysis and FEM Simulation of Flow of Fluids in Pipes

Fluid Flow COMSOL Analysis

Saroj Acharya

Bachelor Thesis
Plastics Technology
2016

DEGREE THESIS	
Arcada	
Degree Programme:	Plastics Technology
Identification number:	14552
Author:	Saroj Acharya
Title:	Analysis and FEM Simulation of Flow of Fluids in Pipes
Supervisor (Arcada):	Mathew Vihtonen
Commissioned by:	Arcada University of Applied Sciences
<p>Abstract:</p> <p>Firstly, the experiment is performed in Arcada Laboratory for fluid flow in a pipe. From the experiment, volumetric flow is calculated with the help of analogue flow meter. This makes it possible to calculate the average velocity of fluid in a pipe. Later, the Reynolds number was calculated to determine the type of flow and that is found to be a turbulent.</p> <p>Secondly, the backstep geometry tutorial of Navier-Stokes incompressible fluid flow is solved in simulation software COMSOL to know the path of simulation. So that, fluid flow performed in the laboratory is done based on that tutorial.</p> <p>Lastly, the turbulent flow simulation is done by modelling the same pipeline as of laboratory experiment using standard COMSOL. After the simulation, different velocity and pressure is observed according to the position of pipe during the flow.</p> <p>The average velocity of fluid was calculated to be 0.532 m/s from the laboratory experiment while the average velocity from the COMSOL simulation was found to be 0.529 m/s. Later, the head loss is calculated using Bernoulli's principle for the experimental and COMSOL values i.e. 2.447 m and 0.65 m respectively.</p>	
Keywords:	Standard COMSOL, Fluid flow module, Turbulent flow, Laminar flow, Velocity, Pressure, Head loss, Bernoulli's principle
Number of pages:	65
Language:	English
Date of acceptance:	15.04.2016

CONTENTS

1	INTRODUCTION	1
1.1	Background	1
1.2	Objectives.....	2
2	LITERATURE REVIEW	3
2.1	Bernoulli`s equation.....	3
2.2	Types of fluid flow	5
2.2.1	<i>Laminar flow</i>	5
2.2.2	<i>Turbulent flow</i>	5
2.2.3	<i>Transitional flow:</i>	5
2.2.4	<i>Reynolds number, Prandtl number and Nusselt number</i>	6
2.3	Entrance Region.....	7
2.3.1	<i>Entry length</i>	8
2.4	Laminar Flow in Pipes	9
2.4.1	<i>Pressure drop</i>	10
2.4.2	<i>Head loss</i>	10
2.5	Turbulent Flow in Pipes.....	10
2.5.1	<i>Head loss</i>	12
2.5.2	<i>Turbulent Shear Stress and Viscosity</i>	14
2.6	Relative Surface Roughness.....	14
2.7	Friction factor	15
2.7.1	<i>For laminar flow</i>	15
2.7.2	<i>For turbulent flow</i>	15
2.8	Flow measurement.....	17
2.8.1	<i>Volumetric Flow Rate</i>	17
2.8.2	<i>Mass Flow Rate</i>	17
2.8.3	<i>Fluid velocity</i>	17
2.9	Pump Efficiency	18
2.10	Heat Transfer.....	18
2.10.1	<i>Conduction</i>	18
2.10.2	<i>Convection</i>	19
2.10.3	<i>Radiation</i>	19
2.10.4	<i>Conjugate Heat Transfer</i>	20
3	METHOD.....	22
3.1	Tutorial COMSOL	23
3.2	Practical COMSOL	29

3.2.1	<i>Laminar flow model</i>	30
3.2.2	<i>Turbulent flow Model</i>	33
3.2.3	<i>Heat Transfer Module</i>	38
3.3	Laboratory Experiment	40
3.3.1	<i>Equipment</i>	40
3.3.2	<i>Pipe Flow Framework</i>	40
4	RESULT	43
4.1	Laboratory Experiment	43
4.2	Tutorial COMSOL	48
4.3	Practical COMSOL	49
5	DISCUSSION	51
6	CONCLUSION	54
	REFERENCES	56
	APPENDIX	62
	TABLES	63

Figures

Figure 1: The development of fluid velocity in a pipe	8
Figure 2: Wall shear stress variation in the direction of flow	9
Figure 3: Laminar flow with velocity profile in a pipe	9
Figure 4: Turbulent flow velocity profile	11
Figure 5: Moody Diagram	16
Figure 6: Modes of Heat Transfer	18
Figure 7: Heat transfer in pipe cross section	20
Figure 8: Resistance diagram	21
Figure 9: The backstep geometry	23
Figure 10: Insertion of Fluid Properties in Laminar Flow	24
Figure 11: Inlet Properties	25
Figure 12: Outlet properties	25
Figure 13: Information on default sign	25
Figure 14: Mesh Properties	26
Figure 15: After Mesh	26
Figure 16: Solution for velocity	27
Figure 17: Post processing visualization of velocity and streamlines	28
Figure 18: Colouring and style in Post-processing	28
Figure 19: Results	28
Figure 20: Laboratory Pipeline	29
Figure 21: Velocity Magnitude in Laminar flow	31
Figure 22: Velocity and Pressure value in inlet and outlet in laminar flow	32
Figure 23: Close view of a pipeline Mesh	34
Figure 24: velocity magnitude in turbulent flow	34
Figure 25: Maximum turbulent velocity	35
Figure 26: Minimum turbulent velocity	35
Figure 27: Velocity field shown by arrow line	36
Figure 28: Pressure contour	36
Figure 29: Velocity and Pressure value in inlet and outlet in turbulent flow	37
Figure 30: Laboratory pipeline	40
Figure 31: Reservoir	41

Figure 32: Pressure Gauge	41
Figure 33: Volumetric flow meter	41
Figure 34: Electric Pump	42
Figure 35: Bar graph of Average velocity from Experiment and COMSOL simulation	51

Tables

Table 1: Velocity and Pressure value at inlet and outlet in laminar and turbulent flow COMSOL simulation	37
Table 2: Properties of Water and Copper	39
Table 3: The velocity obtained from experimental and COMSOL simulation	51
Table 4: Tabulation of Experimental value and COMSOL Value for the calculation of head loss	52
Table 5: Typical values of heat transfer coefficient	63
Table 6: Tabulation of the results done experimentally	64
Table 7: Minor loss coefficient according to the type of component or fitting	65

Equations

Equation 1:	Navier-Stokes equations	1
Equation 2:	Continuity equation	1
Equation 3:	Potential Energy	3
Equation 4:	Kinetic Energy	3
Equation 5:	Flow Energy	3
Equation 6:	Total Energy	3
Equation 7:	Extended form of total Energy	3
Equation 8:	Conservation of Energy	4
Equation 9:	Bernoulli`s Energy Equation	4
Equation 10:	Minor Loss	4
Equation 11:	Major Loss	4
Equation 12:	Reynolds number	6
Equation 13:	Prandtl number	7
Equation 14:	Nusselt number	7
Equation 15:	Nusselt number in a fully developed turbulent flow	7
Equation 16:	Entry length	9
Equation 17:	Pressure Drop	10
Equation 18:	Head loss	10
Equation 19:	Darcy`s Equation	12
Equation 20:	Haaland formula for any surface roughness of a pipe	14
Equation 21:	Friction Factor for laminar flow	15
Equation 22:	Colebrook Equation	15
Equation 23:	Volumetric flow rate	17
Equation 24:	Mass flow rate	17
Equation 25:	Pump Efficiency	18
Equation 26:	Fourier`s law	19
Equation 27:	Newton`s law of cooling	19
Equation 28:	The radiation emitted by a body	19
Equation 29:	Volumetric flow rate	43
Equation 30:	Velocity of water in a pipe	43

List of Symbols

S.N	Name	Symbol	Unit
1	length	l	m
2	Temperature	T	K
3	Mass	m	kg
4	Weight	w	N
5	Pressure	p	Pa
6	Density	ρ	kg/m^3
7	Acceleration due to gravity	g	m/s^2
8	Average velocity	v_{avg}	m/s
9	Area	A	m^2
10	Mass flow rate	\dot{m}	kg/s
11	Volumetric flow rate	\dot{V}	m^3/s
12	Dynamic viscosity	μ	Pa*s
13	Kinematic viscosity	ν	m^2/s
14	Head loss	h_L	m
15	Reynolds number	Re_D	-
16	Prandtl number	Pr	-
17	Nusselt number	Nu	-
18	Internal diameter	D_i	m
19	External diameter	D_o	m
20	Turbulent intensity	i_T	-
21	Turbulence length scale	L_T	m
22	Hydraulic diameter	d_h	m
23	Heat Capacity	c_p	J/kg*K
24	Thermal conductivity	k	W/m*K
25	Overall heat transfer rate	q_r	W/m^2
26	Stefan-Boltzmann constant	σ	$\text{W/m}^2 * \text{K}^4$
27	Emissivity of the body	ϵ	-
28	Heat transfer coefficient	C	$\text{W/m}^2 * \text{K}$

FOREWORD

This thesis is an outcome of my Bachelor in Plastics Technology at Arcada University of Applied Sciences. Moreover, it is also the final step of my academic career at Arcada. During my study in Arcada UAS, I got an opportunity to expand my knowledge on fluid flow. I have tried to analyse the accuracy of fluid flow experiment performed in the laboratory with the use of COMSOL simulation.

All the effort put into this bachelor thesis was not enough without the help of my supervisor, teachers and my classmates. Therefore, I would like to express my gratitude to my supervisor Mathew Vihtonen for his colossal backing and motivation during my thesis work. I also appreciate Harri Anukka and Erland Nyroth for their support during the experiments.

Eventually, I am happy that I am able to close one chapter of my life and move to the next. So, I would like to dedicate this thesis work to my family and friends for their love and support in my daily life.

1 INTRODUCTION

The idea of this investigation is to simulate fluid flow and heat transfer in pipes utilizing an economically accessible COMSOL. Ordinarily, this kind of simulation is performed by Standard COMSOL programming package. COMSOL is intended to have the capacity of arranging numerous sorts of issues from different engineering disciplines such as electricity and magnetism, structural mechanics. The standard COMSOL package is more concentrated on fluid analysis that have better 3D geometry set up and better post processing highlights.[1]

1.1 Background

The foundation for almost all COMSOL fluid flow modelling are the Navier-Stokes mathematical statements. Navier-Stokes equations depict three distinct comparisons. They are momentum equation, energy equation, and continuity equation. At times, Navier-Stokes equations can be simplified. In case of constant density, there is an incompressible Newtonian fluid flow.

$$\rho(\mathbf{u} \cdot \nabla) \mathbf{u} = \nabla [-p\mathbf{I} + \mu\{\nabla \mathbf{u} + (\nabla \mathbf{u})^T\}] + \mathbf{F} \quad (1)$$

$$\rho \nabla \cdot \mathbf{u} = 0 \quad (2)$$

Where,

\mathbf{u} is the fluid flow velocity

ρ is the fluid density

p is the fluid pressure

μ is the fluid dynamic viscosity

\mathbf{I} is the identity matrix

∇ is del operator

\mathbf{T} is stress tensor

The Navier-Stokes equations portray the conservation of momentum, while the continuity equation portrays the conservation of the mass. [2]

1.2 Objectives

The objectives of this thesis are as follows:

1. Demonstrate the use of COMSOL for the simulation of fluid flow.
2. To determine velocity and pressure of flow of water in a pipe by COMSOL simulation and compare it with the results obtained in the laboratory i.e. fluid flow module
3. To observe the heat transfer during the flow of fluids in a pipe and compare it with the results obtained in the laboratory i.e. heat transfer module [3]

2 LITERATURE REVIEW

2.1 Bernoulli's equation

“The law of conservation of energy states that energy can neither be created nor be destroyed, but it can be changed from one form to another.” [4]

There are three forms of energy in fluid flow.

Potential energy (PE) that is related to its height

$$\text{i.e. PE} = w * H \quad (3)$$

$$\text{Or, PE} = mgH$$

The w in the above formula represents the weight and H represents the height.

Kinetic energy (KE) occurs by the act of velocity that is due to the movement of fluid

$$\text{i.e. KE} = w * \frac{v^2}{2g} \quad (4)$$

$$\text{Or, KE} = \frac{mv^2}{2}$$

Third one is Flow or pressure energy (FE)

$$\text{i.e. FE} = \frac{w * p}{\gamma} \quad (5)$$

$$\text{Or, FE} = \frac{w * p}{\rho g} \quad \text{since, } \gamma = \rho g$$

Considering these three forms of energy; the total energy at any point in the flow of fluid in a pipe is:

$$E = PE + KE + FE \quad (6)$$

Hence,

$$E = w * H + w * \frac{v^2}{2g} + w * \frac{p}{\gamma}$$

The conservation of energy principle defines that the total energy at two points is equal if no energy is added or removed. [4]

$$\text{This can be rearranged as } E = mgH + \frac{mv^2}{2} + \frac{mp}{\rho} \quad (7)$$

$$\therefore E_1 = E_2 \quad (8)$$

The substitution is done in the above values and then divided by w on both sides.

Bernoulli's equation states that the sum of various forms of mechanical energy in a fluid along a streamline is the same at all points on that streamline in a steady state flow.

Bernoulli's Energy equation is as follow:

$$\frac{P_1}{\rho} + \frac{v_1^2}{2} + gH_1 = \frac{P_2}{\rho} + \frac{v_2^2}{2} + gH_2 + h_L \quad (9)$$

Where,

h_L – head losses due to friction, fittings, bends and valves

H_1 and H_2 are the height of inlet and outlet

Major losses – friction and pumps

Minor losses - valves, fittings and bends

Typically,

$$h_{L-\text{minor}} = k * \frac{v_{\text{avg}}^2}{2g} \quad (\text{Minor}) \quad (10)$$

Where, k = minor head loss coefficient and

$$h_{L-\text{major}} = f * \frac{L}{D} * \frac{v_{\text{avg}}^2}{2g} \quad (\text{Major}) \quad (11)$$

Where,

f = friction factor

L= pipe length (m)

v_{avg} = average velocity (m/s)

D = internal diameter (m)

g = acceleration due to gravity (m/s^2) [5]

2.2 Types of fluid flow

There are three types of fluid flow. They are as follows:

2.2.1 Laminar flow

The type of flow is critical in fluid dynamics to solve any problems. Laminar flow that is also sometimes called as streamline flow occurs when a fluid particle flows in a straight line parallel to a pipe walls comparatively with low velocity without any disturbance between the layers. Reynolds number is an important parameter to know the type of flow in the tube. The flow with Reynolds number less than 2300 is considered to be a Laminar flow for a pipe. In laminar flow, the velocity, pressure and other flow properties at each point in fluid remain constant. This kind of flow is rare in practice in water systems. [6]

2.2.2 Turbulent flow

It is a type of flow in which fluids undergoes irregular fluctuations and mixing. The magnitude and direction are continuously changing in the turbulent flow due to the speed of fluid at a point. The flow of wind and rivers are the example of this kind of flow. Reynolds number is greater than 4000 and has high velocity in this flow. It is the most common type of flow and has to face the difficulty to view with an open eye, fluctuations are very difficult to detect, and laser can be used for the detection. Mathematical analysis for this flow is very difficult, so experimental measurements are applied. [7]

2.2.3 Transitional flow:

It is a type of flow with the medium velocity having the Reynolds number greater than 2300 and lesser than 4000. [7]

2.2.4 Reynolds number, Prandtl number and Nusselt number

Reynolds number

In 1880, Osborne Reynolds discovered that the stream system mainly depend on the ratio of inertial forces to viscous forces in fluid. The transition in case of laminar to turbulent depends on the geometry, surface roughness, flow velocity, surface temperature, and type of fluid. This ratio is called the Reynolds number and is expressed as an internal flow in a cylindrical pipe as:

$$Re = \frac{\text{Inertial Forces}}{\text{Viscous Forces}} = \frac{v_{avg} * D}{\nu} = \frac{\rho * v_{avg} * D}{\mu} \quad (12)$$

Where v_{avg} = average velocity (m/s),

D = internal diameter (m),

μ = dynamic viscosity (Pa*s) and

$\nu = \frac{\rho}{\mu}$ = kinematic viscosity of fluid (m²/s)

Reynolds number is a dimensionless quantity.

Critical Reynolds number (Re_{cr}): It is defined as the number at which the flow becomes turbulent. The calculation of critical Reynolds number depends on the various parameters. The flow condition and structure of a pipe are the examples of it. For the cylindrical flow inside a pipe, the known value of the critical Reynolds number is $Re_{cr} = 2300$. The representation of Reynolds number for the different types of flow is as:

$Re \leq 2300$ Laminar flow

$2300 \leq Re \leq 4000$ Transient flow

$Re \geq 4000$ Turbulent flow

In case of smooth pipes, it is critical to preserve the laminar flow at much higher Reynolds numbers by maintaining a strategic distance from flow unsettling influences and pipe vibrations. In such painstakingly controlled analyses, the laminar stream has been kept at Reynolds numbers of up to 100,000. [8]

The properties of fluids and the different forms of heat transfer can be described by the following dimensionless number.

Prandtl Number: It is the ratio between fluid ability to store heat and to transfer heat through conduction, independent of the system geometry.

$$Pr = \frac{\mu c_p}{k} \quad (13)$$

The above equation is the calculation formula during the turbulent flow in pipes.

Where, c_p = Heat capacity [J/ (kg*K)], k = Thermal conductivity [W/m*K] and $\mu = 1.002 \cdot 10^{-3}$ [Pa*s] [9]

Nusselt Number: It is the ratio between heat transfer through convection and conduction. The convection inside the tubes can be calculated by the following term.

$$Nu = (CD)/k \quad (14)$$

Where C is the convective heat transfer coefficient of fluid [W/(m²*K)]

D = inside diameter of a pipe [10]

Nusselt number in a fully developed turbulent flow in circular pipes can be calculated by the following formula.

$$Nu_D = 0.023 Re_D^{4/5} Pr^{1/3} \quad (15)$$

Where Nu_D = Nusselt number in cylindrical pipe across diameter (D), Pr = Prandtl number. [11]

2.3 Entrance Region

It is a region where a fluid enters in a circular pipe at uniform velocity. Fluid flowing through a pipe at the surface layer comes to a complete stop due to the no-slip condition. As a result of friction, the velocity of fluid increases as it moves towards the centre of a pipe. This velocity reduction due to friction is overcome by fluid in the mid-section of the larger velocity to keep the mass flow rate constant in a pipe.

The section of fluid stream in which viscous shearing forces are felt due to its viscosity is known as the velocity boundary layer. Hypothetically, boundary layers can be divided into two regions:

- a) Boundary layer region: In this region, fluctuation in the velocity and viscous effects can be seen.
- b) Irrotational flow region: In this region, Velocity is constant in a radial direction whereas the friction is neglected.

The region of boundary layer goes in ascending trend until the layer from the opposite ends meets at the centre of the flow in a pipe. The region starting from the entrance of fluid to the meeting point of two boundary layers is called hydrodynamic entrance region. The region beginning at the junction of two different boundary layers is called hydrodynamically fully developed region. The flow is also known as fully developed until there is a change in temperature of fluid.

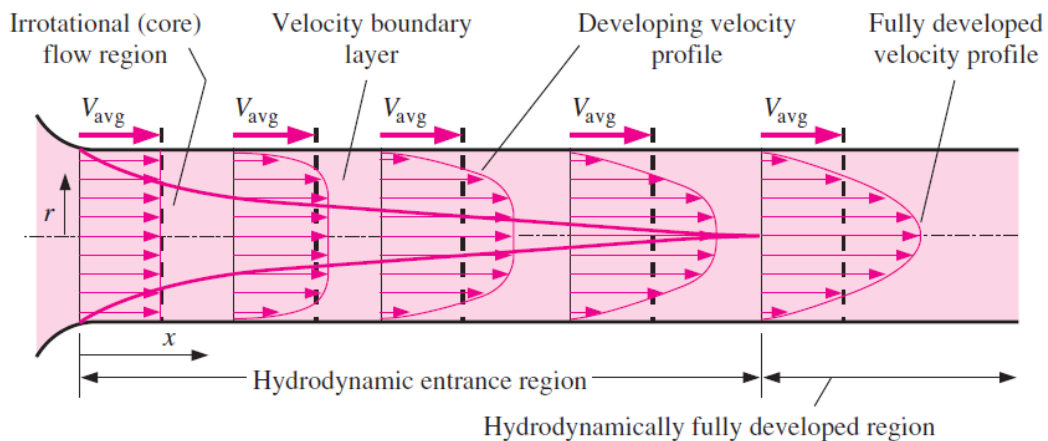

Figure 1: The development of fluid velocity in a pipe [12]

2.3.1 Entry length

The length of the entrance region is called entry length. It is also taken as the distance from fluid entrance to the two percentage wall shear stress of fully developed value. Wall Shear Stress is defined as the shear stress that is located next to the wall of a pipe. In laminar flow, approximate entry length is given as

$$L_{h \text{ Laminar}} \cong 0.05\text{Re}D \quad (16)$$

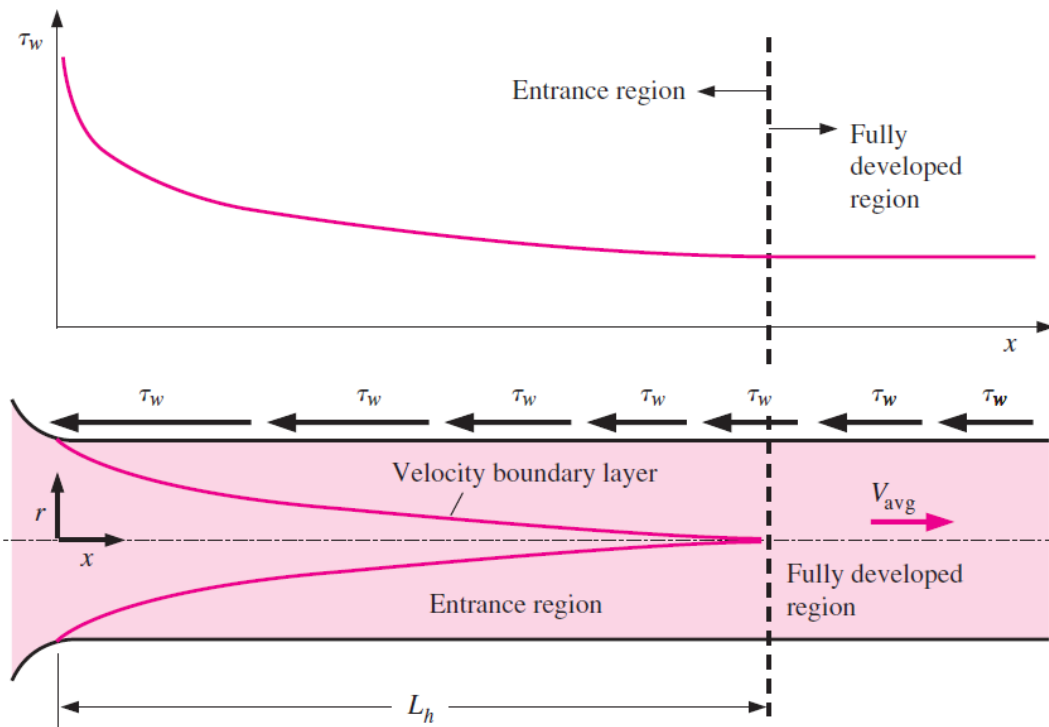

Figure 2: Wall shear stress variation in the direction of flow [13]

2.4 Laminar Flow in Pipes

The flow with Reynolds number less than 2300 is considered to be a Laminar flow for a pipe.

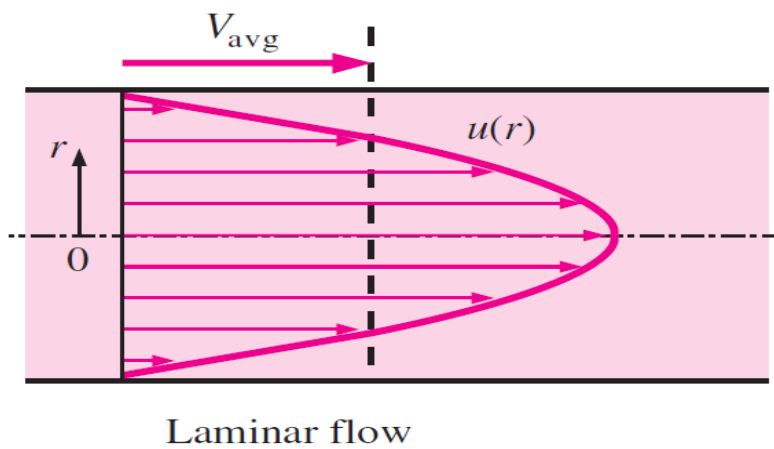

Figure 3: Laminar flow with velocity profile in a pipe [14]

2.4.1 Pressure drop

Pressure drop has a direct relation with the power consumption by the pump to maintain the flow. So, it has been a subject of interest for the analysis of fluid flow. The pressure drop in laminar flow can be calculated by the following formula:

$$\text{Pressure drop } \Delta p = \frac{128\mu L \dot{V}}{\pi D^4}$$
$$\Delta p = \frac{32\mu L v_{\text{avg}}}{D^2} \quad (17)$$

$$\text{Where } \dot{V} = v_{\text{avg}} \frac{\pi D^2}{4}$$

\dot{V} = Volumetric flow rate (m^3/s)

μ = Dynamic viscosity ($\text{Pa}\cdot\text{s}$)

v_{avg} = Average velocity (m/s)

L = Length (m) and

D = Diameter (m) [15]

2.4.2 Head loss

Hagen-Poiseuille's equation is used only for the head loss calculation of laminar flow. The calculation of head loss in a steady laminar flow of incompressible fluid is calculated by the following formula.

For the horizontal pipe with cross-sectional area, head loss is given by

$$h_L = \frac{\Delta p}{\rho g} \quad (18)$$

Where ρ = Density (kg/m^3)

p = Pressure (Pa)

g = Acceleration due to gravity (m/s^2) [16]

2.5 Turbulent Flow in Pipes

It is a most used flow in engineering practice and thus essential to know the turbulence effects in wall shear stress. Despite tremendous research in this sector, engineers are

still unable to find the exact theory regarding the turbulent flow due to its fluctuation complexity.

The development of the velocity boundary layer in a pipe is described by the figure below. Due to the no-slip condition, fluid layer contact with the boundary layer in a pipe come to a complete stop. The velocity of fluid in the adjacent layer from the boundary region keeps slowly increasing towards the central region of a pipe. The thin layer next to the wall is a viscous sublayer where the velocity is linear. The next layer to the viscous sublayer is a buffer layer which is also dominated by the viscous effect. The overlap layer lies just above a buffer layer which is dominated by the turbulent effect. The remaining region is a turbulent layer and has turbulent effect dominating the viscous effect. [17]

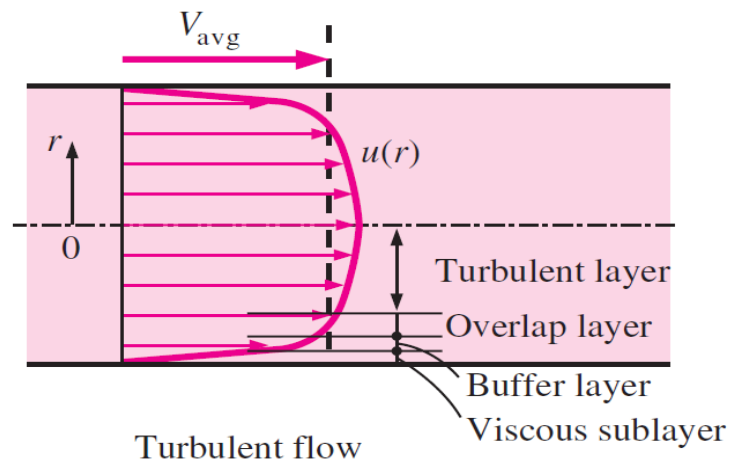

Figure 4: Turbulent flow velocity profile [17]

A turbulence stream demonstrates the arbitrary and fast variety in fluid flow and the condition is known as eddies. The velocity of a flow of this type provides an additional energy that transport mass, momentum and energy to the other region of flow. As a result, turbulent flow has higher values of friction and heat transfer coefficients. [17]

In the COMSOL simulation of turbulent flow, turbulent intensity and turbulence length scale is essential to mention for any Reynolds-averaged Navier-Stokes equations (RANS) turbulence model. In inflow boundary condition, it is better to calculate the turbulent intensity and turbulent length scale value.

Turbulent intensity is a scale defining the turbulence level in percentage and denoted by (i_T). Hence, Turbulent intensity (i_T) = $0.16 \cdot \text{Re}_{d_h}^{-1/8}$ for a fully developed cylindrical flow. [18]

Turbulence length scale is a physical quantity that represents the size of the fluctuation of fluids i.e. eddies in a turbulent flow. In the turbulent flow eddies are used as an inlet parameters. In a fully developed fluid flow in a cylindrical body, it can be calculated with the help of hydraulic diameter (d_h) which is a flow diameter. It can be represented as follows:

$$\text{Turbulence length scale } (L_T) = 0.038 \cdot d_h. \quad [19]$$

2.5.1 Head loss

A certain amount of energy is required to move a given volume of fluid through a cylindrical body. The energy is required for a liquid to move; the pressure difference provides that. The resistance to flow costs some energizing force during the flow. This resistance to flow is called head loss due to friction.

A non-moving liquid at the wall of a pipe reduces the inner diameter of the tube that increases the velocity of fluid passing through it. The head loss from friction is related to the square of the velocity ($v_{\text{avg}}^2/2g$). The liquid in the central part of a pipe has a much higher velocity as compared to the liquid moving at the wall section. [20]

The formula for the calculation of Head loss in fully developed circular flow is below called Darcy's equation.

$$h_L = f \cdot \frac{L}{D} \cdot \frac{v_{\text{avg}}^2}{2g} \quad (19)$$

h_L = Total head loss (m)

f = Friction factor related to the inside roughness of a pipe

L = length of a pipe where fluid flows (m)

D = Internal diameter of a pipe (m)

v_{avg} = Average liquid velocity in a pipe (m/s)

g = acceleration due to gravity ($g = 9.81 \text{ m/s}^2$) [21]

2.5.1.1 Factors that affect Head Loss

The factors affecting the head loss during fluid flow in pipe are as follows:

1. Flow Rate

Flow rate of liquid increases as the velocity increases. It increases the resistance to flow as an act of viscosity. The square of the velocity is linked to the head loss; therefore, the rate of loss is quick.

2. Internal diameter of pipe

Larger inside diameter increases the flow area. As a result, the velocity of the liquid is reduced at a given flow rate. The decreased velocity decreases the head loss due to friction in a pipe. The flow rate decreases with reduced inside diameter and head loss due to friction increases with an increase in velocity.

3. Roughness of a pipe wall

The thickness of non-moving boundary layer increases with the increase in the inside roughness of the tube. As a result, flow areas reduce and cause the rise in the velocity of the liquid and head loss due to friction.

4. Straightness of a pipe

Due to energy, liquid travels in a straight line. The curved path in a pipe disturbs the momentum of fluid. The fluctuation of the liquid occurs in a pipe walls due to energy and the head loss increases. [22]

2.5.2 Turbulent Shear Stress and Viscosity

Viscosity is the resistance in case of fluid flow. The forces of attraction between the molecules held each other and in case of liquid those forces is high enough to keep them together but not enough to put it on the rigid state. Talking about the gasses force of attraction is fragile and cannot hold the mass together. The liquid on the wall surface of a pipe does not move or flow. It is always stationary due to no-slip condition on the wall. Fluid has many surfaces during its flow in a pipe. Fluid flowing over the other surface attaches each other due the force of attraction between them. The liquid layer above the next layer keeps on moving. So that it can be said that there is some shearing forces taking place between these layers. Fluid flows from one to other layers of fluid and needs energy to overcome the friction between them. Viscosity of fluid has a direct relation to the resistance to flow. Due to this, friction loss is higher. [23]

2.6 Relative Surface Roughness

The irregularities in a pipe or some scratches on the internal surface of a pipe disturb the movement of fluid and affect the flow. As compared to the friction factor in laminar flow to that of turbulent flow; turbulent flow is a function of surface roughness. The roughness is a relative concept and has a significant role when the height ε is comparable to the sublayer of laminar flow in fluid which acts as a function of Reynolds number. In Fluid Mechanics, any surface which has the peaks of roughness stick out of the laminar sublayer is considered as being rough. Any surface is described as the smooth one when the sub layer suppresses the roughness elements present. Glass and plastic surfaces are generally considered to be hydrodynamically smooth. Relative roughness $\frac{\varepsilon}{D}$ and Reynolds number has a significant role in friction factor in fully developed turbulent pipe flow. Relative roughness can be defined as the ratio of the mean height of roughness of a pipe to that of a pipe diameter. Haaland has given an equation for calculating any surface roughness of a pipe.

$$\frac{1}{\sqrt{f}} = -1.8 \log_{10} \left\{ \frac{6.9}{\text{Re}_D} + \left(\frac{\varepsilon/D}{3.71} \right)^{1.11} \right\} \quad (20) [24]$$

2.7 Friction factor

Friction factor (f) is a dimensionless quantity that depends on the velocity, density diameter and viscosity. It is also a function of wall roughness that depends on the size of ε . The general form of friction factor can be written as:

$$f \propto \left(\text{Re}, \frac{\varepsilon}{D} \right) \quad [25]$$

2.7.1 For laminar flow

In laminar flow, Friction factor is only dependent on Reynolds number. The following equation gives the friction factor for fully developed laminar flow in circular pipes.

$$f = \frac{64}{\text{Re}_D} \quad (21)$$

This equation is independent of $\frac{\varepsilon}{D}$ i.e. inside roughness of pipe and dimensionless [26]

2.7.2 For turbulent flow

In Turbulent flow, friction factor is calculated on the basis of surface roughness of pipe and Reynolds number. Colebrook equation and Moody diagram are the essential part of friction factor calculation in turbulent flow.

2.7.2.1 Colebrook equation

In 1939, Cyril.F.Colebrook founded a formula for the calculation of friction factor by combining the data of transition and turbulent flow both in smooth and rough pipes known as Colebrook equation. It calculates friction loss coefficients in pipes, tubes, and ducts. It works only on turbulent flow condition.

$$\frac{1}{\sqrt{f}} = -2 \log_{10} \left[\frac{\varepsilon/D}{(3.7)} + \frac{(2.51)}{\text{Re}_D \sqrt{f}} \right] \quad (22) \quad [27]$$

2.7.2.2 Moody Diagram

Laminar and turbulent flow has variation, and due to this reason, it creates difficulties to determine the friction coefficient and make impossible to identify it in the transient phase i.e. if the flow consists of Reynolds number higher than 2300 and lesser than 4000 Friction factor lies between the laminar value having Reynolds number equal to

2300 and the turbulent value of 4000. Darcy-Weisberg major loss equation can be calculated by the use of Moody friction factor. The Moody diagram below helps in determining the friction factor. [28]

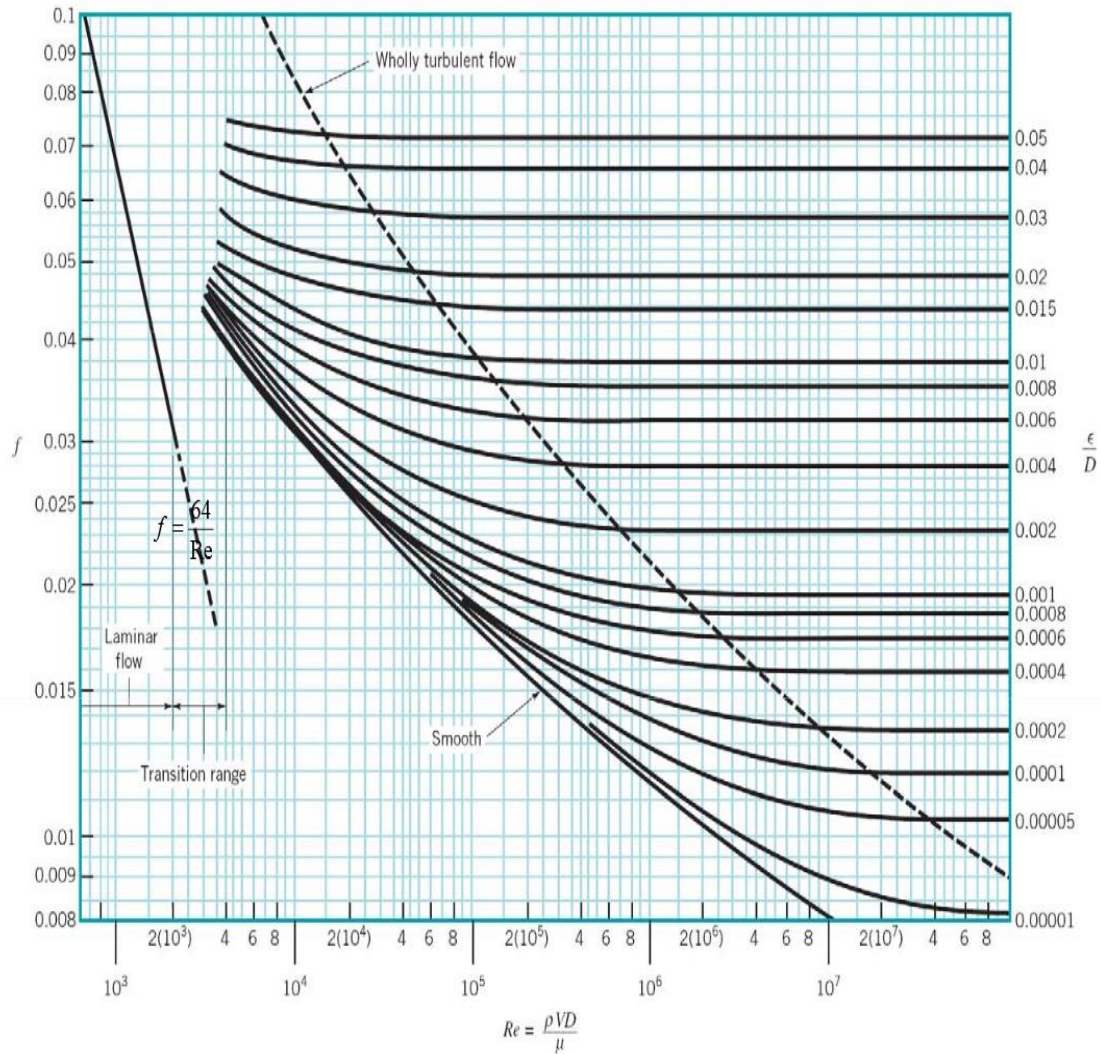

Figure 5: Moody Diagram [29]

2.8 Flow measurement

Flow measurement is regarded as a measurement of fluid velocity within the tubes. It can be measured by Venturimeter i.e. pressure difference based meter. Mechanical flow meters such as Turbine flow meter and Piston meter are also used for the measurement. [30]

2.8.1 Volumetric Flow Rate

It is defined as the Volume of fluid that flows past a given cross-sectional area per second. Its SI unit is m^3/s . Volumetric flow rate is a part of mass flow rate since mass has a relation with volume by means of density. It can be calculated as the product of the cross-sectional area (A) of flow and the average flow velocity (v_{avg}).

$$\therefore \dot{V} = v_{\text{avg}} * A \quad (23) [31]$$

2.8.2 Mass Flow Rate

Mass flow rate is defined as the measure of the mass of fluid passing through a point. Its unit is kg/s . The mass flow rate is related to the volumetric flow rate as explained above. It can be calculated as the product of density (ρ) and volumetric flow (\dot{V}).

$$\dot{m} = \rho * \dot{V}$$

$$\text{Or, } \dot{m} = \rho * v_{\text{avg}} * A \quad (24) [32]$$

2.8.3 Fluid velocity

Average velocity is defined as the average speed through a cross section of a pipe. For a Fully developed laminar pipe flow average velocity is the half of the maximum velocity. Fluid velocity changes from zero to the maximum at the centre of a pipe due to no-slip condition. The average velocity may change during the heating and cooling of fluids due to the change in the density with temperature. Practically, the properties of fluid are calculated at an average temperature and treat that as a constant.

$$v_{\text{avg}} = \frac{\dot{V}}{A}$$

[33]

2.9 Pump Efficiency

Pump efficiency is defined as the ratio of product of volumetric flow rate and pressure head of the pump to input power. Pump efficiency is the dimensionless quantity and expressed in the form of percentage.

$$\eta = \frac{\dot{V}\Delta P}{\text{Input power}} * 100 \% \quad (25)$$

Where \dot{V} = Volumetric flow rate

Δp = Pressure head of pump [34]

2.10 Heat Transfer

Heat transfer is the phenomenon related to temperature and the flow of heat where the temperature represents the thermal energy and flow of heat represent the movement of thermal energy from a hotter body to colder one. Temperature difference is the driving force that causes heat to be transferred. The Modes of heat transfer are shown in the figure below. [35]

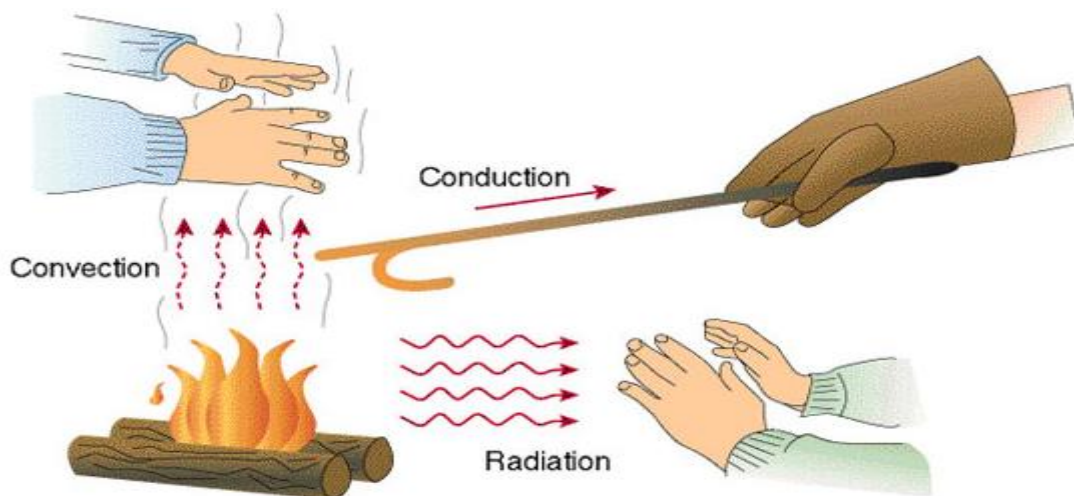

Figure 6: Modes of Heat Transfer [36]

2.10.1 Conduction

Conduction is the process of transfer of heat as a consequence of molecular movement and the ensuing exchange of kinetic energy. Conduction is predominant in solid materials and static fluids. Joseph Fourier in 1822 propounded the law of heat conduction and

later named it as a Fourier's law. It states, "*The heat flux, resulting from the thermal conduction is proportional to the magnitude of the temperature gradient and opposite to it in sign.*"

$$q = -k \frac{dT}{dx} \quad (26)$$

Where 'k' is a thermal conductivity and the unit is W/m*K [37]

2.10.2 Convection

Convection is the flow of heat as a result of macroscopic movement of matter from a hot to a cold region. In 1701, Sir Isaac Newton founded the law of thermal convection and considered as the Newton's law of cooling. *Newton's Law of Cooling states that the rate of change of the temperature of an object is proportional to the difference between its own temperature and the temperature of its surroundings.*

$$q = C(T_{\text{body}} - T_{\text{fluid}}) \quad (27)$$

Where T_{fluid} = temperature of the oncoming fluid at constant body temperature

T_{body} = temperature of a body

C = Heat transfer coefficient at a point on the surface

The unit of C is W/m²*K

[38]

2.10.3 Radiation

Radiation is the transfer of energy in the form of rays or waves or particles (α, β, γ)

The radiation emitted by a body is given by

$$\dot{Q} = \epsilon \sigma A T^4 \quad (28)$$

Where ϵ = the emissivity of the body

σ = the Stefan-Boltzmann constant = $5.67 * 10^{-8}$ W/ m²*K⁴

A = the body surface area (m²)

T = the absolute temperature (K) [39]

2.10.4 Conjugate Heat Transfer

Conjugate heat transfer is the term corresponds to an environment where there is a combination of heat transfer in solids and heat transfer in fluids. In heat transfer in solids, conduction has a vital role while the convection has a significant role in fluids heat transfer. In this process, the heat is transferred from the warm liquid present inside a pipe towards the cold pipe wall. And finally to the environment where there is a low temperature as compared to fluid inside a pipe. In conclusion, heat is dissipated by increasing the exchange area between fluid inside a pipe and the solid pipe. The fusion of heat transfer in solids and fluids can be applied to save the energy losses in various devices. It is because many fluids act as thermal insulators due to the properties of having small thermal conductivities. [40]

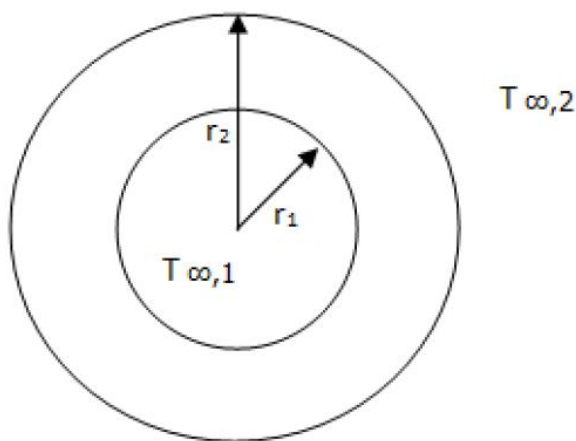

Figure 7: Heat transfer in pipe cross section [41]

In the figure above, it is a pipe having the inside and outside radius of r_1 and r_2 respectively. Fluid inside a pipe has a warm temperature ($T_{\text{fluid},1}$) that transfers in the wall of a pipe. It is followed by the outside cold temperature ($T_{\text{fluid},2}$) comparatively colder than the inside temperature of a pipe. Here, $2\pi rL$ is the lateral area of a pipe. T_{∞} in a figure above is considered as T_{fluid} . k is the thermal conductivity of a pipe. The following resistance diagram represents the way of transfer of heat from the inside of a pipe to the surrounding environment. T_s in the figure below is the temperature of a solid and it is written as T_{body}

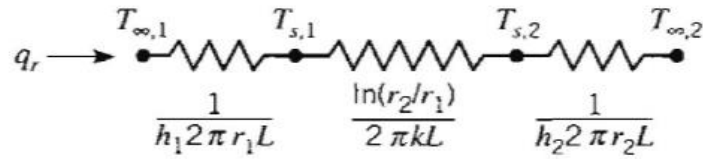

Figure 8: Resistance diagram

[42]

Where,

q_r = Overall heat transfer rate (W/m^2)

h_1 in the above figure is replaced by C_1 = convective heat transfer coefficient of flowing water inside a pipe $\text{W}/\text{m}^2 \cdot \text{K}$

h_2 in the above figure is replaced by C_2 = convective heat transfer coefficient of air $\text{W}/\text{m}^2 \cdot \text{K}$

L = Length of pipe (m)

$T_{\text{body},1}$ = Temperature of inner wall surface (K) and

$T_{\text{body},2}$ = Temperature of outer wall surface (K)

Therefore, the final heat equation is as follows

$$q_r = \frac{T_{\text{body},1} - T_{\text{body},2}}{\frac{1}{C_1 2\pi r_1 L} + \frac{\ln\left(\frac{r_2}{r_1}\right)}{2\pi k L} + \frac{1}{C_2 2\pi r_2 L}}$$

[43]

3 METHOD

The three methods were used in order to find the solution of the topic. COMSOL simulation is the primary method for the study of the topic so that it is mostly focused. The methods are as follows:

1. Tutorial COMSOL
2. Practical COMSOL
3. Laboratory Experiment

COMSOL is the dominant physics simulation software in which Finite element method (FEM) and Partial differential equation are solved. The abilities of the software expand into the following eight add-on modules. Those are AC/DC, Chemical Engineering, Heat Transfer, and Structural Mechanics. Model libraries and supporting software such as Livelinks for SolidWorks and CAD have developed by the company. [44]

COMSOL has many convenient features that have made this software a boon to the many engineers. It has developed in such a way that it is very easy to use for the simulation and modelling of real-world multiphysics. As a result, COMSOL has been a leading provider and developer of technical computing software. COMSOL is now the primary tools for engineers, researchers, and lecturers in the education and high tech product designs fields. [45]

COMSOL simulation is a fundamental apparatus for the development of a new product. It includes various applications such as chemical, mechanical, electrical, and fluid. While talking about the need to couple the physics affecting a system; COMSOL simulation helps by providing an integrated simulation platform. COMSOL has been the unique simulation power offered which allows the present day's researchers and engineers to design the products in a short interval of time with low price. In conclusion, design challenges between physical effects interactions can be solved by the COMSOL Software. [46]

3.1 Tutorial COMSOL

The Steady Incompressible flow tutorial in COMSOL version 4.3 is solved in the newer COMSOL version 4.4. Steady incompressible Navier-Stokes backstep geometry models help to examine the physics of the geometry in the absence of external forces. In the geometry below, fluid enters from the narrower region towards the wider region making a velocity profile of parabolic structure.

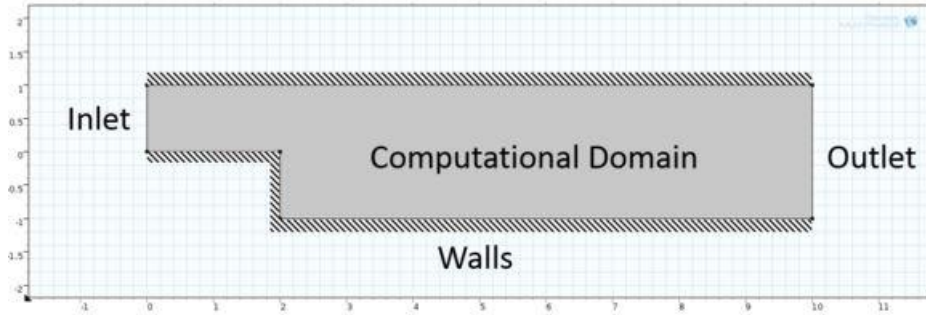

Figure 9: The backstep geometry [47]

The velocity components of fluid $\mathbf{u} = (u, v)$ is computed in the x and y axis and the pressure p in the region is defined by the geometry of the above figure. The stationary incompressible Navier-Stokes equations are used by the Partial Differential Equation (PDE) model of this application. The equations are as follows:

$$\rho(\mathbf{u} \cdot \nabla)\mathbf{u} = \nabla [-p\mathbf{I} + \mu\{\nabla\mathbf{u} + (\nabla\mathbf{u})^T\}] + \mathbf{F} \quad (1)$$

$$\rho \nabla \cdot \mathbf{u} = 0 \quad (2)$$

The first equation is the balance of momentum from Newton's second law. The second equation is the equation of continuity, where zero on the right-hand side states that fluid is incompressible. The pattern of the flow depends only on the Reynolds number.

The properties are as follows:

$$\text{Dynamic viscosity } (\mu) = 1.79 \cdot 10^{-5} \text{ Pa}\cdot\text{s}$$

$$\text{Density } (\rho) = 1.23 \text{ kg/m}^3 \quad [47]$$

First of all, software for the analysis of COMSOL Multiphysics is opened, and the selection of laminar flow model is done for the simulation. Under fluid flow, single phase

flow and laminar flow were selected respectively. After the selection of flow model, study method was chosen as a stationary in which the field variables do not change according to the time. Then the geometry of the backflow is drawn. Here, a property of air is taken as fluid.

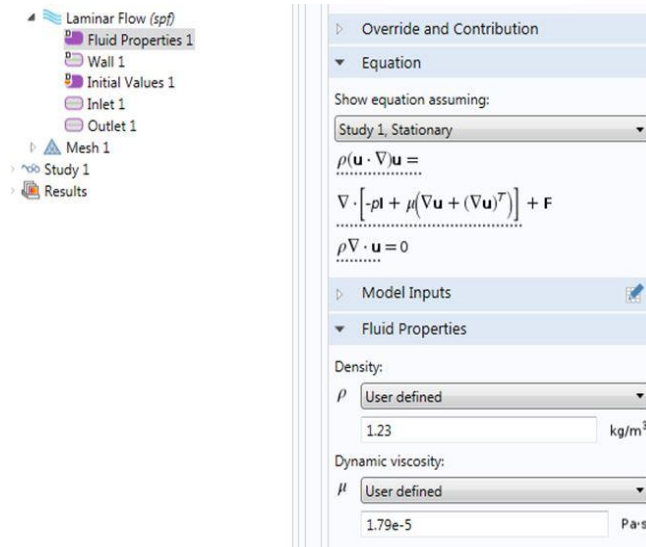

Figure 10: Insertion of Fluid Properties in Laminar Flow

Inlet

Average velocity was $V_{\text{mean}} = 0.554$ m/s used by COMSOL in this model and the same velocity were used to solve this tutorial. The u and v value was set as $(u, v) = (6 \cdot V_{\text{mean}} \cdot s \cdot (1-s), 0)$ at 'normal inflow velocity' in an inlet boundary condition to obtain the parabolic velocity profile. In 2D, the 's' in the inlet velocity box above denotes the internal variable ranges from 0 to 1. The arrows in the edge mode during post processing define the direction. The $s \cdot (1-s)$ is a parabola beginning and ending at 0 for 's' value 0 and one respectively. This parabolic form represents the velocity flow in a 'no-slip' wall condition. The use of 's' is less evident in 3D geometry so it does not exist. [48]

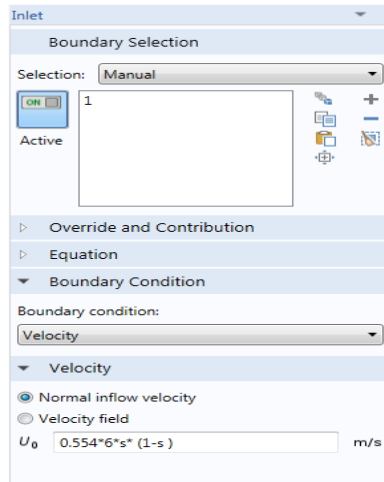

Figure 11: Inlet Properties

Outlet

At outlet, pressure was selected as a boundary condition and was zero as a suppress backflow.

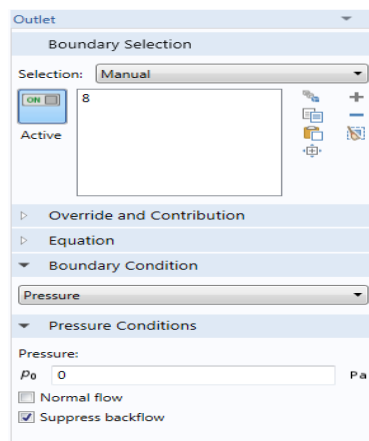

Figure 12: Outlet properties

“D” in the corner of fluid properties in the model builder of following figure is known as default.

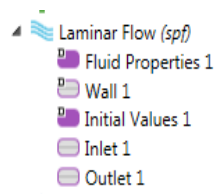

Figure 13: Information on default sign

Meshing

After inserting all properties, meshing is another step for the COMSOL simulation of the laminar flow under fluid analysis. Meshing is defined as the representation of geometric shapes expressed as a set of finite elements. In this flow analysis, all of the meshes created were physics controlled and automatically generated. The meshes varied in size ranging from a coarser mesh all the way up to a ‘normal mesh’

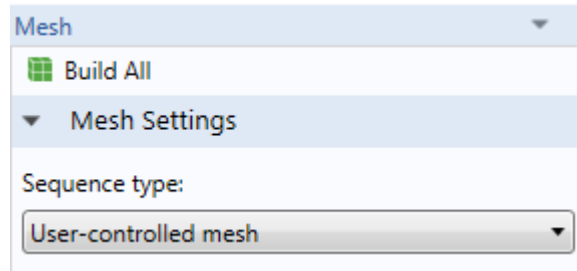

Figure 14: Mesh Properties

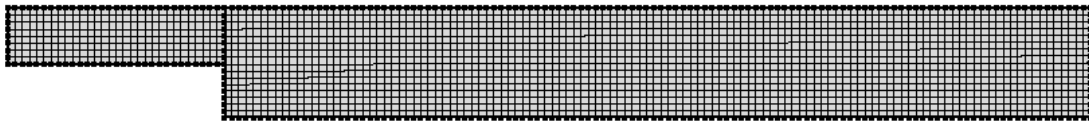

Figure 15: After Mesh

Study

After the meshing process, backflow geometry was then subjected to simulate for the velocity magnitude. On the “Home” toolbar, “compute” was clicked to find the result of the velocity magnitude. The velocity distribution was found out by the computation where the difference in the velocity is shown by the various colour as in the figure below. The velocity at the boundary layer is zero and keeps increasing while moving towards the central region.

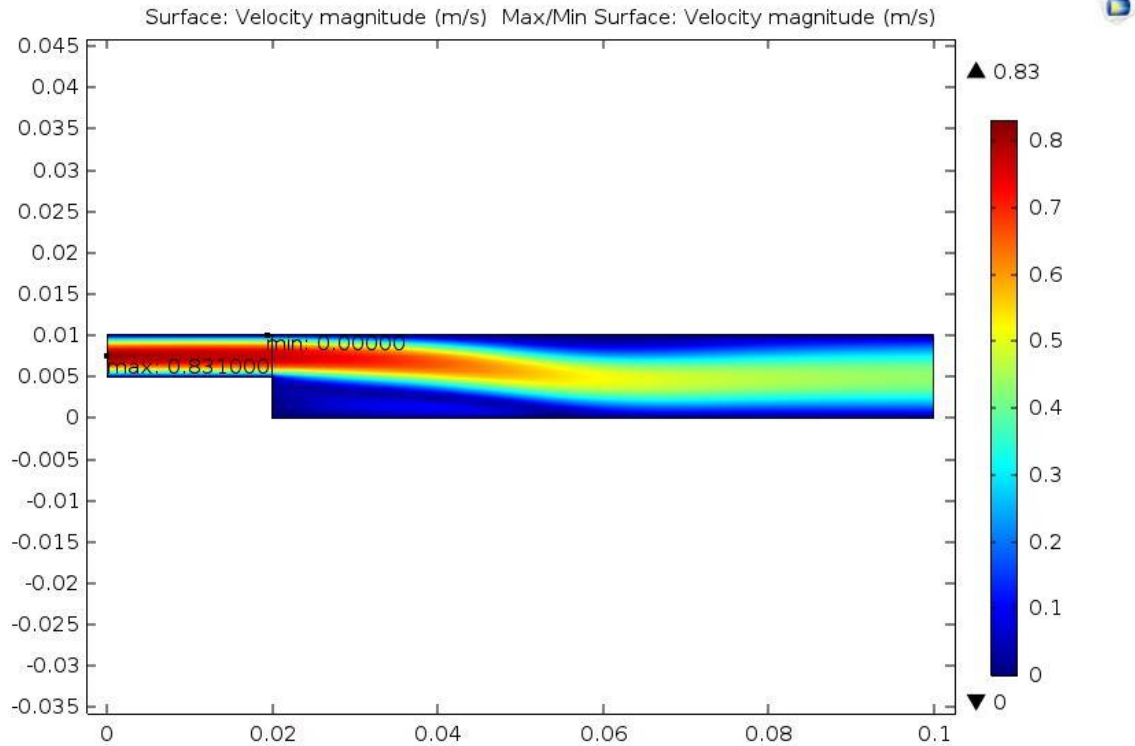

Figure 16: Solution for velocity

Post Processing

In the post processing and visualization, a combination of arrow and surface plots were used to see the velocity field and pressure field simultaneously. “Plot parameters” was chosen to open the plot parameters dialog box from the post processing menu. Then the “surface” tab was clicked. “Pressure” was selected from the “pre-defined quantities” list on the “surface Data” page. “Arrow” tab was clicked followed by “Arrow plot” check box. Hence, “OK” was clicked to view the combined plot.

“Plot Parameters” dialog box was reopened. Streamline plot was added and arrows were removed by selecting the “Streamline” check box and the “arrow” check box was cleared on the “general” page. “Streamline” tab was clicked and “start points” was selected to 20 to specify the number. Then “line colour” tab was clicked followed by “colour” button. The lightest grey swatch was clicked in “Streamline Colour” dialog box, then “OK” was clicked. Finally, “OK” was clicked to close the “Plot Parameters” dialog box and the new plot was displayed. [49]

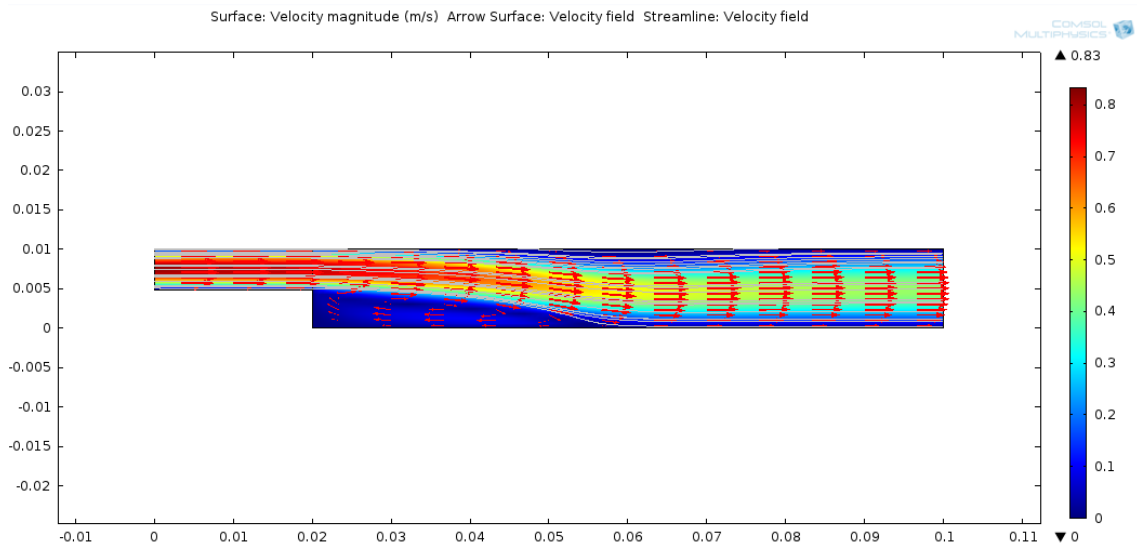

Figure 17: Post processing visualization of velocity and streamlines

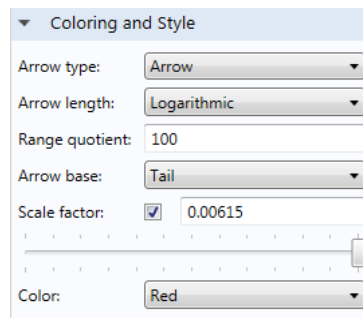

Figure 18: Colouring and style in Post-processing

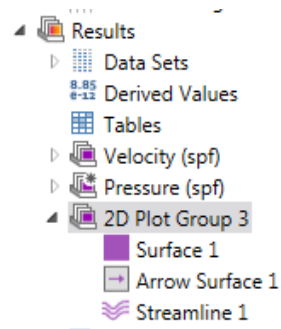

Figure 19: Results

3.2 Practical COMSOL

A pipeline in the heat transfer laboratory was taken as a reference and was designed in SolidWorks software. It can be imported in the COMSOL software as (Virtual Reality Modelling Language) VRML file type but in this case it was difficult to solve. So, the geometry of design was drawn on the COMSOL graphics after inserting every property. After the successful simulation of turbulent flow, different values in the pipeline were detected for velocity and pressure.

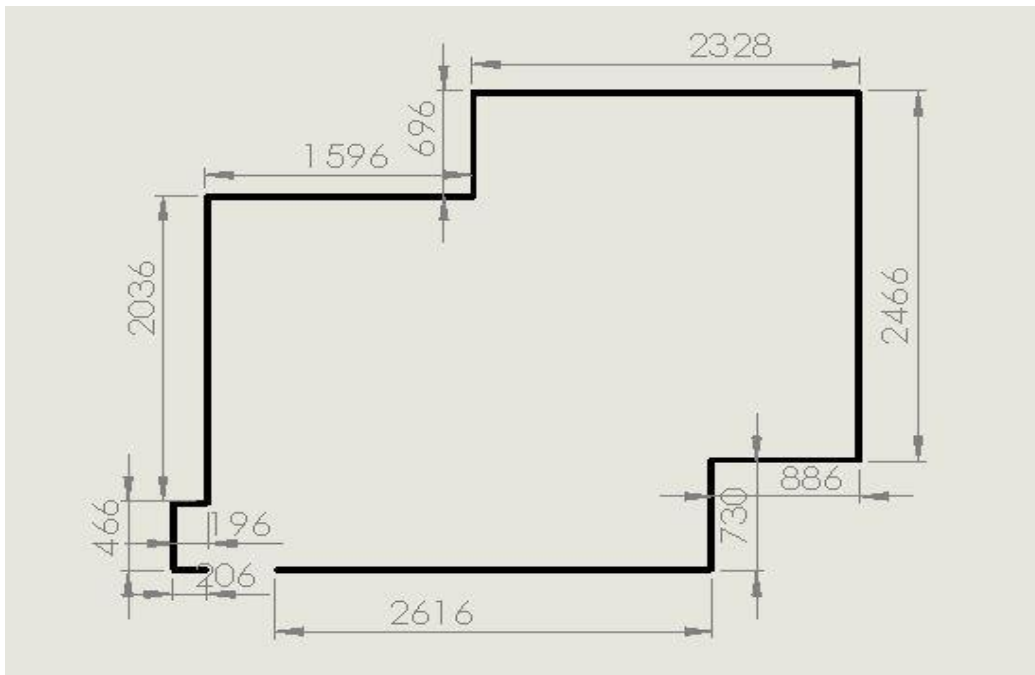

Figure 20: Laboratory Pipeline

Conditions for fluid flow COMSOL analysis:

Incompressible flow

Density (ρ): Water (1000 kg/m^3)

Viscosity (μ): $1.002 \cdot 10^{-3} \text{ Pa}\cdot\text{s}$

Inlet Pressure (P_i): 248 kPa

Outlet Pressure (P_o): 224 kPa

3.2.1 Laminar flow model

First of all, software for the analysis of COMSOL Multiphysics is opened, and the selection of laminar flow model is done for the simulation. Under fluid flow, single phase flow and laminar flow were selected respectively. After the selection of flow model, study method was chosen as a stationary in which the field variables do not change according to the time. Then the geometry of a pipe channel was drawn in the COMSOL as that of laboratory.

Another step of the analysis was to set up the correct domains and input necessary boundary conditions. The flow was selected as an incompressible. In COMSOL, there are many default boundary conditions such as fluid properties, initial values and wall condition. But under the laminar flow in the model builder, fluid property was selected. The selection of the domain was done in fluid property where the density and the dynamic viscosity of fluid were inserted. The initial value was kept as a default one, and the 'Wall property' was considered as 'No-slip' where the velocity of fluid is in the rest. In the model builder, under the laminar flow, it was then essential to add inlet boundary condition in fluid properties that was done by right clicking on the laminar flow under the model builder. Inlet was selected as the boundary condition where the normal inflow velocity was inserted. Outlet Boundary condition was also chosen in the same way as that of inlet. At outlet, "pressure" was chosen as a boundary condition in another end of pipeline geometry and normal flow was selected in the check box.

After inserting all properties, meshing is another step for the COMSOL simulation of the laminar flow under fluid analysis. Meshing is defined as the representation of geometric shapes expressed as a set of finite elements. In this flow analysis, all of the meshes created were physics controlled and automatically generated. The meshes varied in size ranging from a coarser mesh all the way up to a 'normal mesh'. [50]

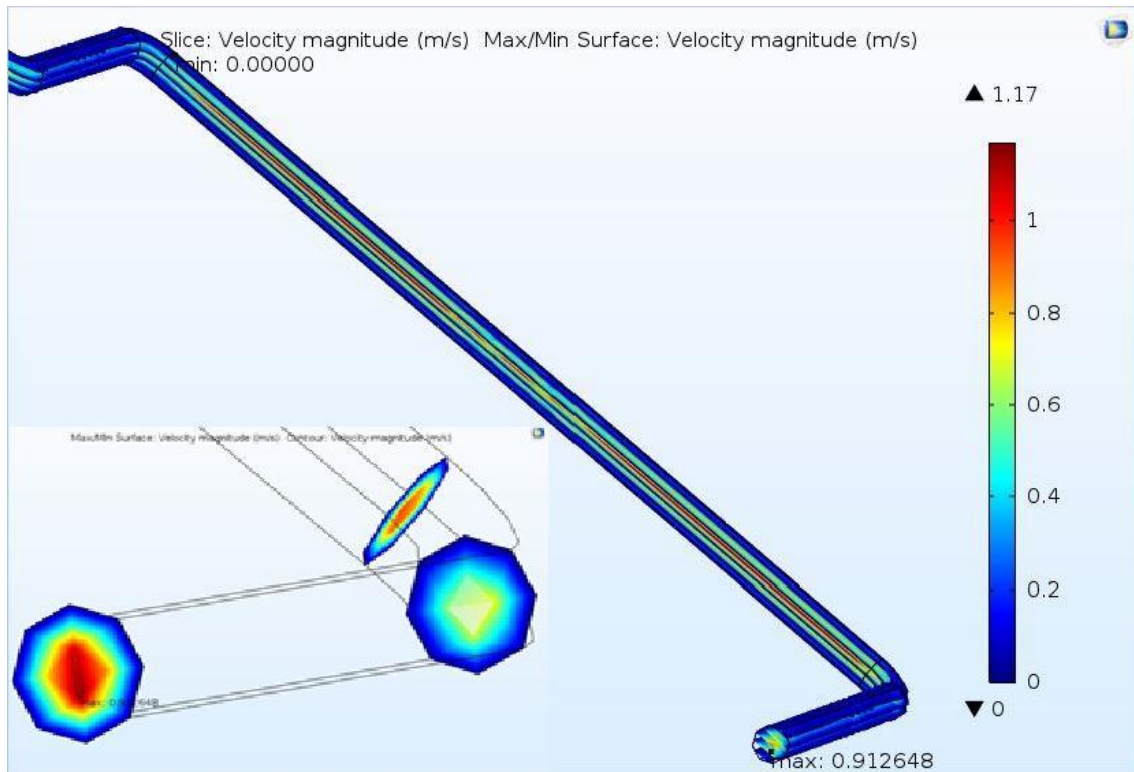

Figure 21: Velocity Magnitude in Laminar flow

In the Results toolbar, further processing is done. The point evaluation for the pressure and velocity in the different region of the flow was done in the results section. From this evaluation, inlet and outlet values for the pressure and velocity were extracted from a pipeline after the simulation. The scale in the above figure is called legends that describe the change in velocity by colour variation in it. In the figure below, point 76 is the centre point of inlet and the point 74 is the centre point of outlet.

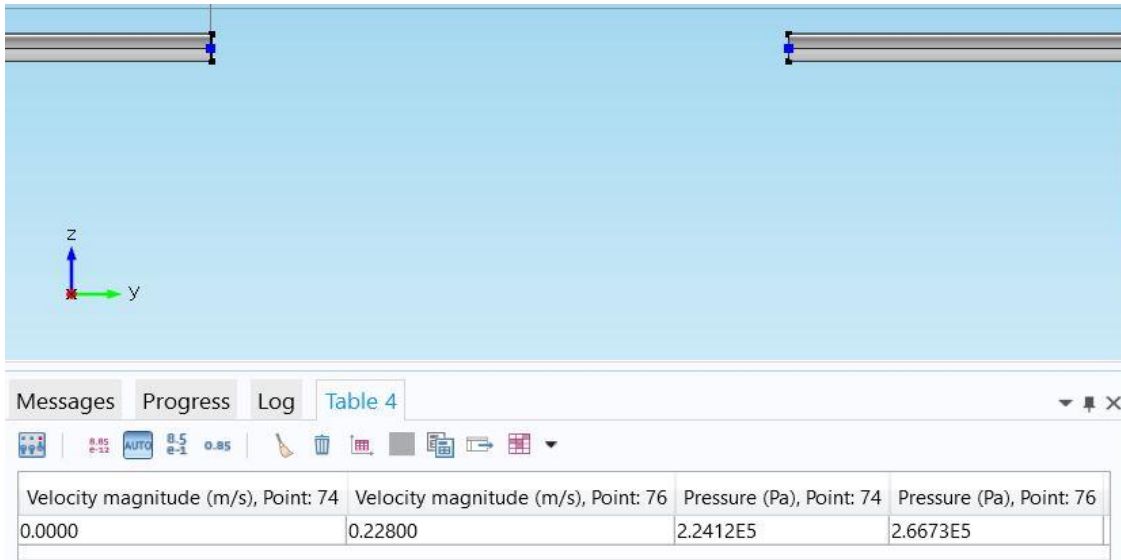

Figure 22: Velocity and Pressure value in inlet and outlet in laminar flow

3.2.2 Turbulent flow Model

Turbulent flow model simulation in COMSOL is a bit different from the laminar flow. In turbulent flow, k- ϵ approach was selected as a turbulence model due to its good convergence rate and relatively low memory requirements. The k- ϵ model is the most common two-equation turbulence model. The convection and diffusion of turbulent energy is calculated by this model. “k” is a variable of turbulent kinetic energy that determines energy in turbulence while “ ϵ ” is turbulent dissipation variable that determines the scale of the turbulence. [51]

Initially, the 3D model was chosen for the simulation of fluid flow, single phase flow and turbulent flow correspondingly. After these physics settings, stationary study method was used. Hence, a COMSOL model builder was seen in the screen.

A simulation of the model was then started with the geometry of pipeline. The geometry was drawn in the COMSOL graphics with required unit of measurement. After the successful design of the graphics, Compressibility was selected as “incompressible flow” in the physics model as an interface identifier. Later, fluid properties present in the turbulent flow were added where the density (ρ) 1000 kg/m³ and dynamic viscosity (μ) 1.002*10⁻³ were inserted. In initial values settings, average velocity 0.532 m/s was inserted as a reference value from the laboratory experiment in the y-axis as the geometry was drawn in the same axis and 2 * 10⁵ Pa pressure value as in the laboratory. In wall settings, “wall functions” was selected as the boundary condition for the wall.

The “inlet” was added in the model builder under turbulent flow. In the settings window for inlet, the velocity was selected and average velocity was placed. There is a difference in “inlet” settings between the laminar and turbulent flow. In this flow, in velocity boundary condition, turbulent length scale and intensity must be specified. Turbulent intensity (i_T) = 0.05 and turbulence length scale (L_T) = 7.6 * 10⁻⁴ m were calculated as explained in the theory section and inserted respectively in the boundary condition. Again, the “outlet” was added in the model builder under turbulent flow. Pressure condition was located and outlet pressure was inserted. The normal flow was selected in the check box. After inserting the value for boundary condition, mesh was done using user-controlled mesh followed by solving [52]

Mesh is performed for the successful simulation of the flow. The following figure is the mesh of a pipeline. As the mesh is very small to view properly, the close view of mesh is shown below. The design can be zoomed by pressing the mouse roller in and out for the close view.

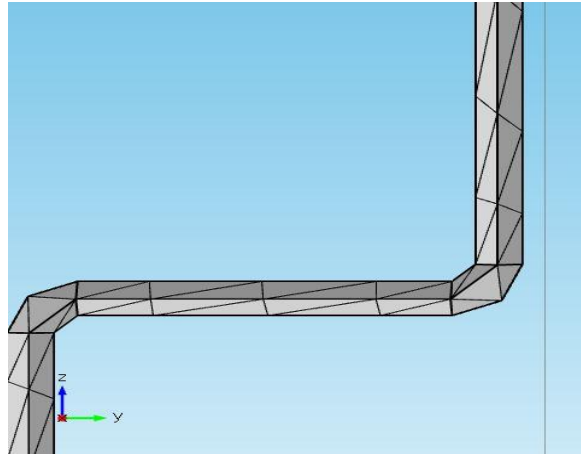

Figure 23: Close view of a pipeline Mesh

The velocity magnitude is shown in the figure below. Different colour seen in the legends represents the difference in velocity according to the position of a pipe. The maximum and minimum velocity is also located in a pipeline figure below.

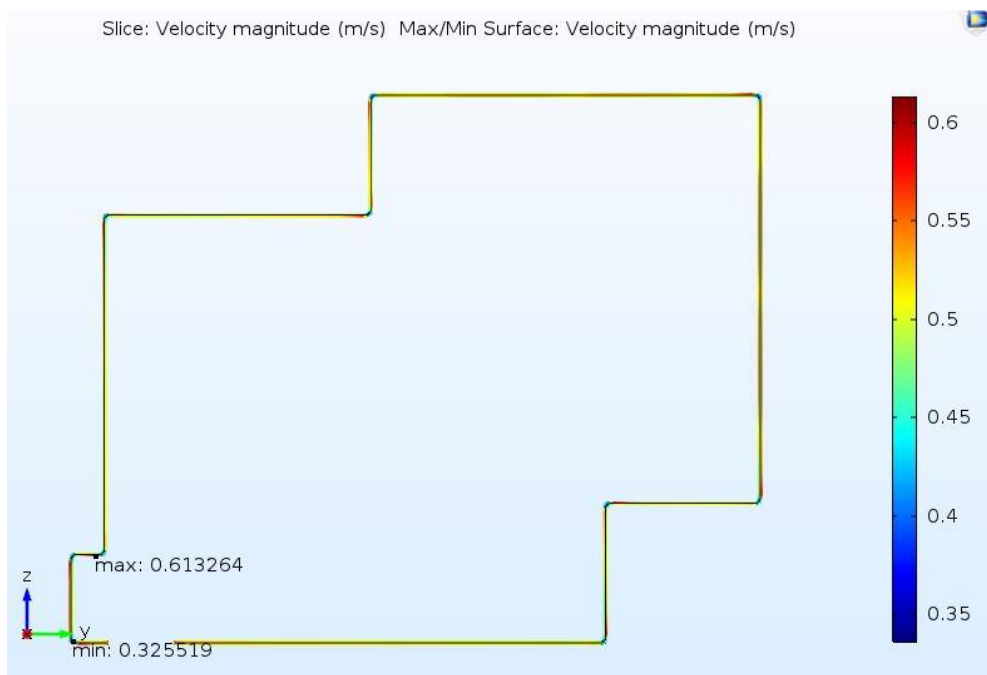

Figure 24: velocity magnitude in turbulent flow

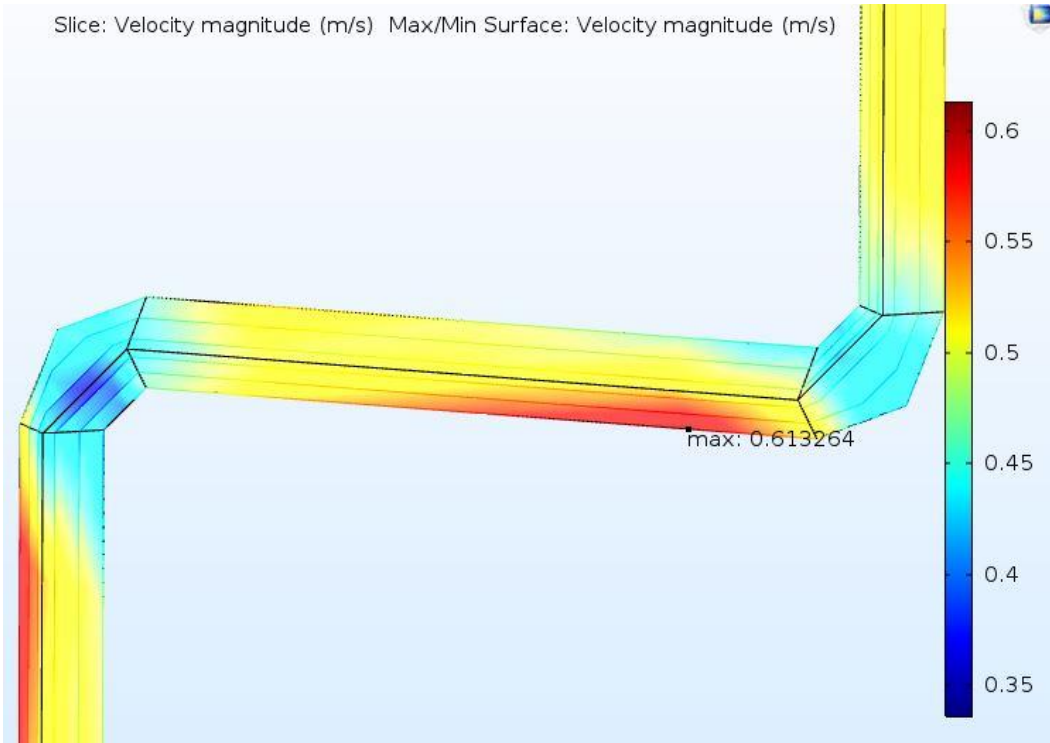

Figure 25: Maximum turbulent velocity

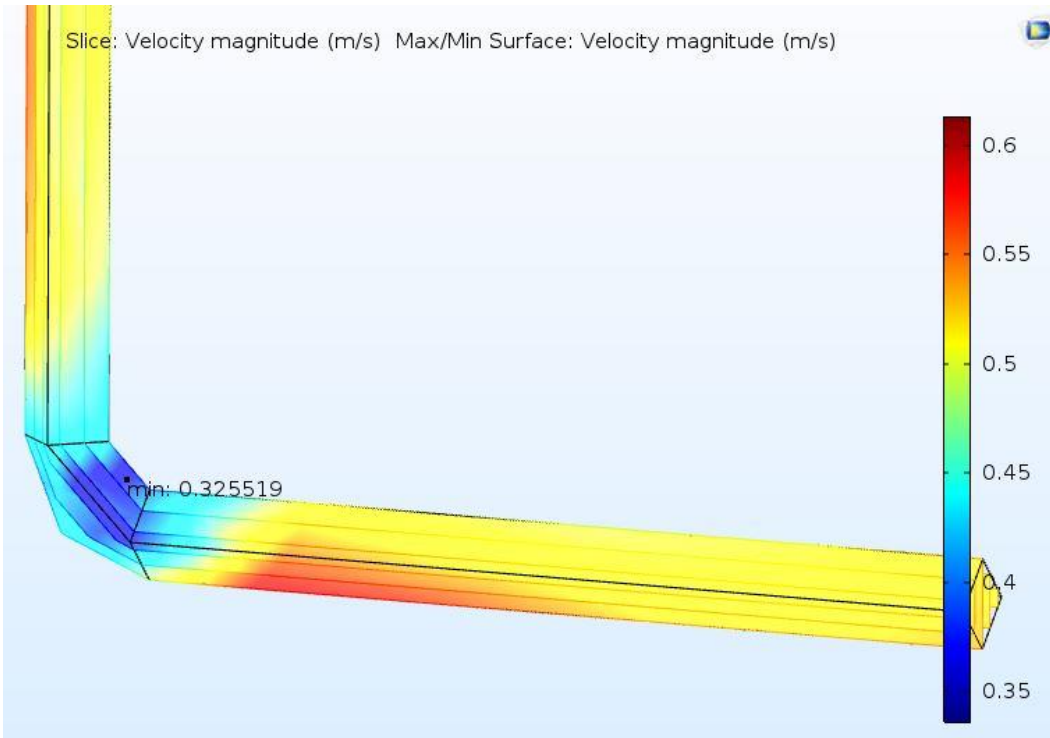

Figure 26: Minimum turbulent velocity

The arrow in a pipeline shows the path of the flow of fluid. The longer arrow in the figure shows that velocity is high in that region.

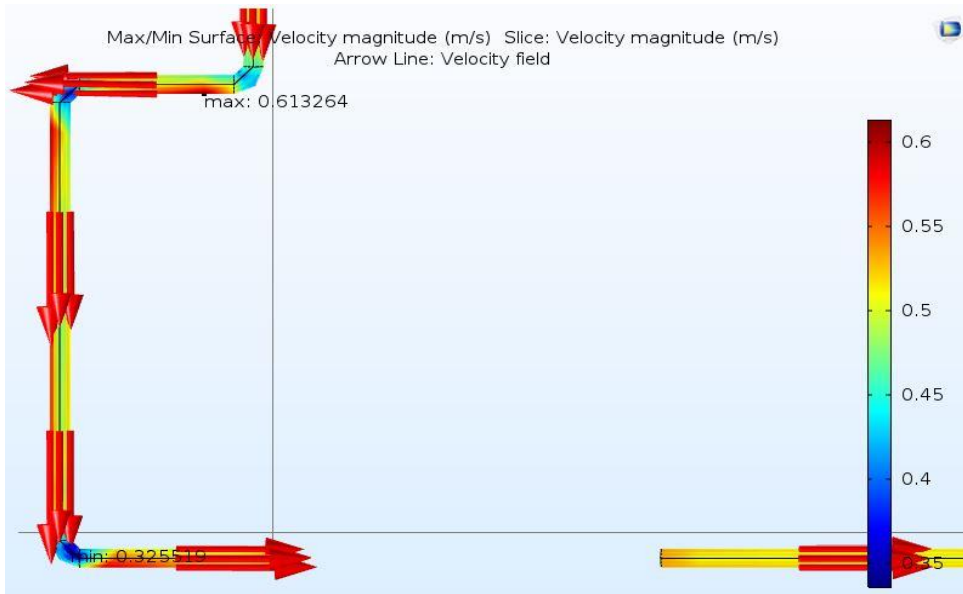

Figure 27: Velocity field shown by arrow line

The pressure in the different region of pipeline is represented by the variation in the colour shown in the figure below. The figure shows that the pressure is in decreasing order starting from inlet towards outlet.

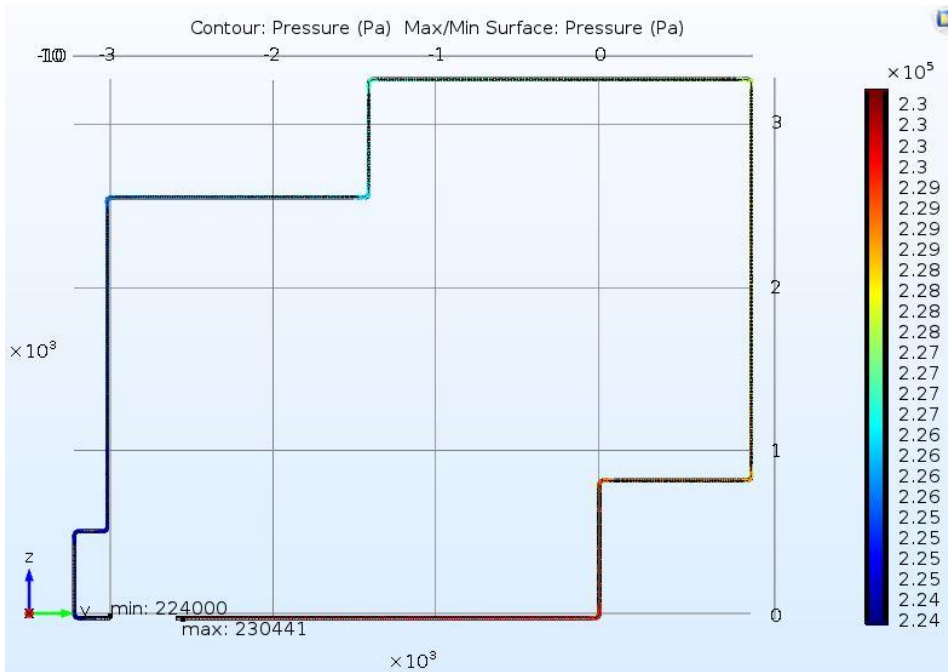

Figure 28: Pressure contour

In the figure below, point 76 is the centre point of inlet and the point 74 is the centre point of outlet.

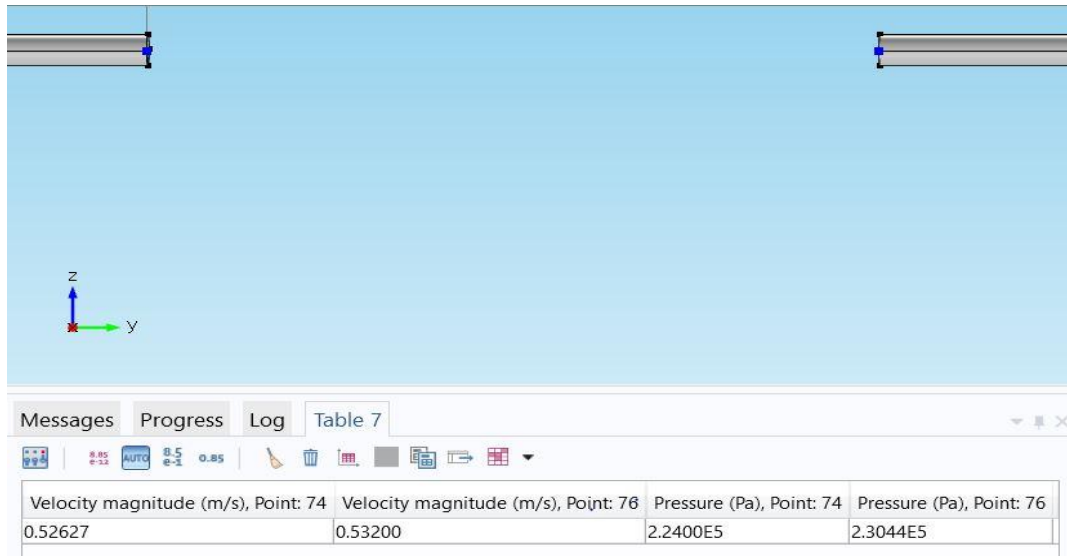

Figure 29: Velocity and Pressure value in inlet and outlet in turbulent flow

In the Results toolbar, further processing is done. The point evaluation for the pressure and velocity in the different region of the flow was done in the results section. From this evaluation, inlet and outlet values for the pressure and velocity were extracted from a pipeline after the simulation. These extracted values can be used for the head loss calculation using Bernoulli's equation. In velocity section, Max/Min Volume is added to know the point of maximum and minimum value. In Pressure section, Contour is added to view the different value of pressure in a pipeline. Finally, report is added to view the whole process during the simulation. The simulation results of both the type of flow are summarized in the table below:

Table 1: Velocity and Pressure value at inlet and outlet in laminar and turbulent flow COMSOL simulation

	Turbulent		Laminar	
	Velocity (v) (m/s)	Pressure (kPa)	Velocity (v) (m/s)	Pressure (kPa)
Inlet	0.53200	230.44	0.22800	266.73
outlet	0.52627	224.00	0.00	224.12

3.2.3 Heat Transfer Module

The successful simulation turbulent flow in fluid flow module leads to the Heat Transfer simulation of fluid in a pipe. Heat transfer analysis and either laminar flow or turbulent flow is coupled, and a simulation process is known as Conjugate heat transfer. This combining simulation can be proved as a tough task as compared to fluid flow.

First of all, COMSOL is opened, and the 3D model was selected. After the selection of the model, non-isothermal flow physics was chosen for the simulation that has also been proved to be a best method to couple the heat transfer method and fluid flow method. Stationary study was chosen in this case too and was added in the COMSOL, model builder. Then model was either imported or drawn in the graphics section by using available geometrical shapes.

The primary task of this simulation is to setup correct domains. This simulation is a bit complicated as compared to the simulation of flow only. It is because in this type of simulation many domains in a single model such as fluid flow analysis, heat transfer in liquid and heat transfer to the solid are simulated at an only time.

Under isothermal flow in the model builder, default heat transfer model for fluid was chosen. All the domains were selected, and the properties were input. After inserting the values into isothermal flow; fluid properties were inserted in the non-isothermal flow. The Properties were thermal conductivity, fluid type, density of the material, heat capacity at constant pressure, ratio of specific heats, and dynamic viscosity.

No-slip and wall functions were the wall condition selected for laminar and turbulent analysis respectively. Initial values and other properties were inserted in the COMSOL module in a similar manner as before. Heat transfer in solids was added in the non-isothermal flow in order to know the amount of heat transferred to the copper pipe. Solid properties are set by adding the material to the solid. In this case, water and copper properties are set for the analysis. In the model builder under the non-isothermal flow, inlet and outlet were set, and the respective properties were inserted. Then the inlet and outlet were added under the non-isothermal heading, and boundary conditions and their individual properties were also inserted. Inlet temperature and wall temperature were also added under the non-isothermal flow by right clicking on the heading. Then the

outflow condition was set as flow outlet and its boundary condition was also inserted. Finally, the model was ready for the simulation.

Table 2: Properties of Water and Copper

Properties	Water	Copper
Thermal Conductivity (k)	0.6 W/m*K (293 K)	385 W/m*K
Heat capacity (c_p)	4186 J/kg*K	384.4 J/kg*K
Density (ρ)	1000 kg/m ³	8940 kg/m ³

[53]

3.3 Laboratory Experiment

3.3.1 Equipment

The equipment used in the laboratory experiment is as follows:

1. Digital pressure gauge
2. Water pump
3. Vernier caliper and measuring tape
4. Analogue flow rate meter
5. Stopwatch
6. Pipe
7. Water as a fluid flowing in a pipe

3.3.2 Pipe Flow Framework

A pipe flow experiment helps in determining the experimental backbone on how to apply engineering equations in a real life situation where fluid flows. This analysis is mainly oriented to find the velocity of fluid flow in a pipe. The operation is performed at the Heat Transfer lab located at the Arcada University of Applied Sciences. During the test, water from the reservoir is used as fluid flowing in the stream channel by using a pump. The water flowing through a channel travels in a pipe network and again collects in the reservoir. It is a cyclic process in the laboratory.

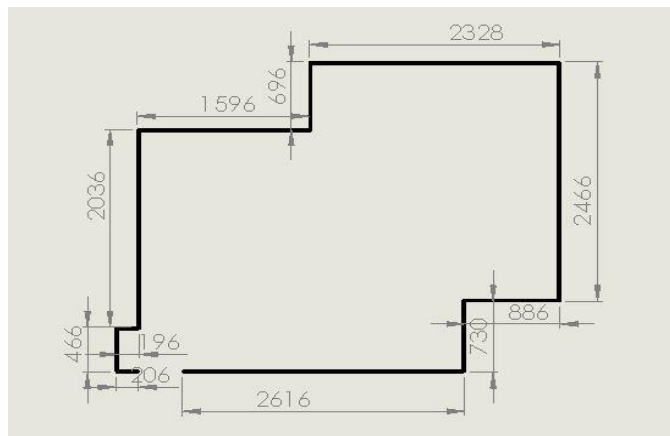

Figure 30: Laboratory pipeline

1. Reservoir: The water storage house is mainly called reservoir where the process of incoming and outgoing flow of water continues during the experiment.



Figure 31: Reservoir

2. Digital Pressure Gauge: It is connected to a pipe channel at the starting and ending point of flow. The inlet pressure gauge reads 248 kPa while the outlet gauge reads 224 kPa and the pressure difference is found to be 24 kPa.



Figure 32: Pressure Gauge

3. Analogue flow meter: It is the flow meter that is attached to a pipe network to read analogously. The number of revolutions made by the flow meter was five times. The flow meter has ten units and time taken as shown by stop watch was 30s.



Figure 33: Volumetric flow meter

4. Pump: The pump helps in pumping the water in a pipe network. In this experiment, the power reading in the pump was 22W.



Figure 34: Electric Pump

4 RESULT

Description of the various calculation and results obtained from different types of study are as follows:

4.1 Laboratory Experiment

The known values for the calculation are:

Power of the Pump = 22 W

Inlet Pressure = 248 kPa

Outlet Pressure = 224 kPa

Inside diameter of a pipe = 20 mm = 0.02 m

Outside diameter of a pipe = 22 mm = 0.022 m

Flow Rate =?

Velocity =?

Head loss =?

Calculating Flow rate,

The Analogue flow meter has a dial of 10 units which revolved 5 times in 30s.

1 revolution = 0.0001 m³

So,

$$\text{Volumetric flow rate } (\dot{V}) = \frac{\text{Number of revolution} \times \text{flow meter unit}}{\text{Time taken (s)}} \quad (29)$$

$$\text{Or, Volumetric Flow rate} = \frac{50 \times 10^{-4}}{30}$$

$$\therefore \text{Volumetric Flow rate} = 1.67 \times 10^{-4} \text{ m}^3/\text{s}$$

Calculating Velocity,

$$v_{\text{avg}} = \frac{\dot{V}}{A} \quad (30)$$

where A is the cross-sectional area of a cylindrical pipe

$$\text{Or, } A = \pi r^2 = 3.1416 \times (0.01)^2 = 3.1416 \times 10^{-4} \text{ m}^2$$

$$\text{Or, } v_{\text{avg}} = \frac{1.67 \times 10^{-4}}{3.1416 \times 10^{-4}}$$

$$\text{Or, } v_{\text{avg}} = 0.532 \text{ m/s}$$

Calculation of Reynolds number,

$$Re_D = \frac{\rho V_{avg} D}{\mu}$$

Where $\rho = 1000 \text{ kg/m}^3$

$v_{avg} = 0.532 \text{ m/s}$

$D = 0.02 \text{ m}$ (Diameter is used for the Reynolds number calculation of fully developed internal flow)

The dynamic viscosity (μ) = $1.002 * 10^{-3} \text{ Pa}\cdot\text{s}$

Now,

$$Re_D = \frac{\rho V_{avg} D}{\mu}$$

$$\text{Or, } Re_D = \frac{1000 * 0.532 * 0.02}{1.002 * 10^{-3}}$$

$$\text{Or, } Re_D = 10618.76$$

This Reynolds number value is greater than 4000. Hence, it determines that the flow is turbulent.

Calculation of head loss experimentally,

The Head loss calculation is done by using the following Bernoulli's equation.

$$\frac{P_1}{\rho} + \frac{v_1^2}{2} + gH_1 = \frac{P_2}{\rho} + \frac{v_2^2}{2} + gH_2 + h_L$$

Where, h_L is the head loss occurs due to friction. Actually, head loss is the length representation of pressure difference across experimental pipe. The experiment is performed on a pipe which has same inlet and outlet height. i.e. $H_1=H_2$. The flow is fully developed one so that the velocity at the two ends of a pipe is same. i.e. $v_1=v_2$. Total head loss (h_L) is given in unit m^2/s^2 .

$$\text{Or, } h_L = \frac{(P_1 - P_2)}{\rho}$$

$$\text{Or, } h_L = \frac{(248 * 10^3 - 224 * 10^3)}{10^3}$$

$$\text{Or, } h_L = 24 \text{ m}^2/\text{s}^2$$

Now, this value is divided by acceleration due to gravity, g (m/s^2) to obtain the value in meter (m).

$$\text{Hence, } h_L = \frac{24 \text{ m}^2/\text{s}^2}{9.806 \text{ m/s}^2}$$

$$\therefore h_L = 2.447 \text{ m}$$

Calculation of head loss by friction factor,

The formula for the calculation of Head loss in fully developed circular flow is below called Darcy's equation.

$$h_{L-\text{major}} = f * \frac{L}{D} * \frac{V_{\text{avg}}^2}{2g}$$

h_L = Total Head Loss

f = Friction factor related to the inside roughness of a pipe i.e. 0.013 taken from Moody Diagram

L = length of a pipe where fluid flows i.e. 14.2 m

D = Internal diameter of a pipe i.e. 0.02 m

v_{avg} = Average liquid velocity in a pipe i.e. 0.532 m/s

g = Acceleration due to gravity ($g = 9.806 \text{ m/s}$)

$$\text{Or, } h_{L-\text{major}} = f * \frac{L}{D} * \frac{V_{\text{avg}}^2}{2g}$$

$$\text{Or, } h_{L-\text{major}} = 0.013 * \frac{14.2}{0.02} * \frac{(0.532)^2}{2 * 9.806}$$

$$\text{Or, } h_{L-\text{major}} = 0.133 \text{ m}$$

Calculation of minor head loss due to number of bends:

Total number of bends = 10

From table 6, regular 90° elbows has minor coefficient (k) = 0.3

So, minor loss equation for the bends is given by,

$$\text{Or, } h_{L-\text{minor}} = k \frac{v_{\text{avg}}^2}{2g}$$

$$\text{Or, } h_{L-\text{minor}} = 0.3 * \frac{0.532^2}{2*9.806}$$

$$\text{Or, } h_{L-\text{minor}} = 4.33 * 10^{-3} \text{ m}$$

Hence, the total head loss is found to be

$$h_L = h_{L-\text{major}} + h_{L-\text{minor}}$$

$$\text{Or, } h_L = (0.133 + 4.33 * 10^{-3}) \text{ m}$$

$$\therefore h_L = 0.138 \text{ m}$$

Calculation of Prandtl Number (Pr):

$$\text{Pr} = \frac{\mu * c_p}{k}$$

Where,

μ is the dynamic viscosity

c_p = heat capacity

And k is thermal conductivity

$$\text{Or, } \text{Pr} = \frac{1.002*10^{-3}*4186}{401}$$

$$\therefore \text{Pr} = 1.046 * 10^{-2}$$

Calculation of Nusselt Number:

Nusselt number in a fully developed turbulent flow in circular pipes can be calculated by the following formula.

$$\text{Nu}_D = 0.023 \text{Re}_D^{4/5} \text{Pr}^{1/3}$$

Where Nu_D = Nusselt number in cylindrical pipe across diameter (D), Pr = Prandtl number

$$\text{Or, } \text{Nu}_D = 0.023 \text{Re}_D^{4/5} \text{Pr}^{1/3}$$

$$\text{Or, } \text{Nu}_D = 0.023 * 10618.76_D^{4/5} * (1.046 * 10^{-2})^{1/3}$$

$$\text{Or, } Nu_D = 0.023 * 1662.87 * 0.22$$

$$\text{Or, } Nu_D = 8.41$$

The convection inside the tubes can be calculated by using Nusselt number.

Calculation of Overall heat transfer rate:

Overall heat transfer rate is given by:

$$q_r = \frac{T_{\text{body},1} - T_{\text{body},2}}{\frac{1}{C_1 2\pi r_1 L} + \frac{\ln\left(\frac{r_2}{r_1}\right)}{2\pi k L} + \frac{1}{C_2 2\pi r_2 L}}$$

q_r = Overall transfer rate (Wm^2)

C_1 = convective heat transfer coefficient of flowing water inside a pipe [$W / (m^2K)$]

C_2 = convective heat transfer coefficient of air [$W / (m^2K)$]

L = Length of pipe (m)

Inside diameter of a pipe = 20 mm = 0.02 m

Outside diameter of a pipe = 22 mm = 0.022 m

T_1 = Temperature of inner wall surface (K) and

T_2 = Temperature of outer wall surface (K).

So,

$$q_r = \frac{313 - 306}{\frac{1}{3000 * 2 * \pi * 0.02 * 14.2} + \frac{\ln\left(\frac{0.022}{0.02}\right)}{2 * \pi * 401 * 14.2} + \frac{1}{200 * 2 * \pi * 0.022 * 14.2}}$$

$$q_r = \frac{7}{1.87 * 10^{-4} + 2.66 * 10^{-6} + 2.55 * 10^{-3}}$$

$$q_r = \frac{7}{2.74 * 10^{-3}}$$

$$q_r = 2554.74 \text{ W/m}^2$$

4.2 Tutorial COMSOL

The Navier-Stokes incompressible fluid problem was solved by following the path of COMSOL 4.3b that was later solved in the new version COMSOL 4.4. The obtained value of velocity from the analysis was 0.831 m/s and exactly the same as in the previous version.

4.3 Practical COMSOL

The Reynolds number was calculated by using the velocity obtained to find the type of flow. It was found to be 10618.76 i.e. above 4000. This indicates the flow as turbulent. Then the turbulent flow simulation was used in COMSOL to find the velocity magnitude of the flow. The velocity magnitude in the inlet and outlet was found to be 0.532 m/s and 0.526 m/s respectively.

The velocity obtained from the COMSOL was compared well with that pressure drop by lab equipment of Arcada. In real flows and non-uniform velocity in the cross section, Bernoulli's principle can be used and can be written as follows.

$$\frac{P_1}{\rho} + \frac{v_1^2}{2} + gH_1 = \frac{P_2}{\rho} + \frac{v_2^2}{2} + gH_2 + h_L$$

In head loss calculation from the values obtained from the turbulent flow COMSOL simulation, different velocity and pressure was observed in inlet and outlet of a pipe. Head loss calculation is done by the values obtained from COMSOL simulation by using Bernoulli's equation. Bernoulli's equation is given by,

$$\frac{P_1}{\rho} + \frac{v_1^2}{2} + gH_1 = \frac{P_2}{\rho} + \frac{v_2^2}{2} + gH_2 + h_L$$

Where h_L is given in m^2/s^2

$$\text{Or, } h_L = \frac{(P_1 - P_2)}{\rho} + \frac{v_1^2}{2} - \frac{v_2^2}{2}$$

$$\text{Or, } h_L = 6.4097 + 0.1415 - 0.1418$$

$$\text{Or, } h_L = 6.4097 \text{ m}^2/\text{s}^2$$

Now, this value is divided by acceleration due to gravity, g (m/s^2) to obtain the value in meter (m).

$$\text{Hence, } h_L = \frac{6.4097 \text{ m}^2/\text{s}^2}{9.806 \text{ m/s}^2}$$

$$\therefore h_L = 0.65 \text{ m}$$

Calculation of Turbulent intensity,

As explained in the theory turbulent intensity is given by

$$\text{Turbulent intensity } (i_T) = 0.16 * \text{Re}_{d_h}^{-1/8}$$

Where d_h is the hydraulic diameter in a fully developed flow

Re is Reynolds number

$$\text{Or, } (i_T) = 0.16 * 10618.76^{(-\frac{1}{8})}$$

$$\therefore (i_T) = 0.05$$

Calculation of Turbulence length scale,

As explained in the theory turbulent length scale is given by

$$\text{Turbulence length scale } (L_T) = 0.038 * d_h$$

$$\text{Or, } (L_T) = 0.038 * 0.02$$

$$\therefore (L_T) = 7.6 * 10^{-4} \text{ m}$$

5 DISCUSSION

The velocity of fluid in turbulent flow was calculated to be 0.532 m/s from the laboratory experiment for a maximum pressure drop of 5 Pa. The Reynolds number was calculated to find the type of flow. It was found to be 10618.76 i.e. above 4000. This indicates the flow as turbulent. Then the turbulent flow simulation was used in COMSOL to find the velocity magnitude of the flow. The average velocity from the COMSOL simulation was found 0.529 m/s. The velocity found experimentally and from COMSOL simulation is approximately the same. Whereas, average laminar Velocity obtained from the COMSOL simulation for the same design was found 0.114 m/s. Average velocity obtained from the different analysis are tabulated below.

Table 3: The velocity obtained from experimental and COMSOL simulation

1	Average Velocity obtained from Laboratory experiment	0.532 m/s
2	Average turbulent Velocity from the inlet and outlet obtained by COMSOL simulation for the same design	0.529 m/s
3	Average laminar Velocity from the inlet and outlet obtained by COMSOL simulation for the same design	0.114 m/s

This data in the above table can be represented in the bar graph using excel.

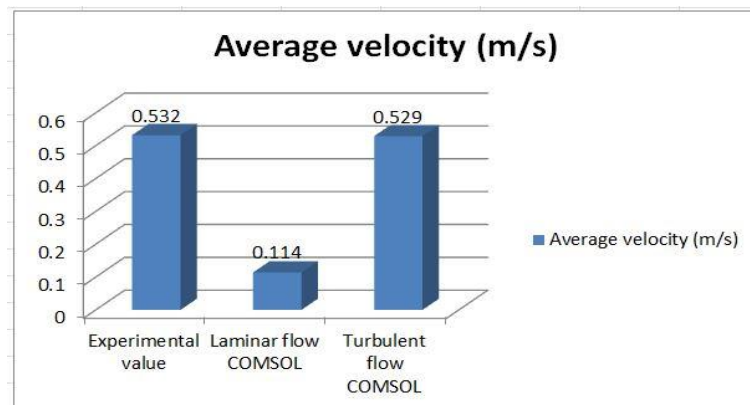

Figure 35: Bar graph of Average velocity from Experiment and COMSOL simulation

Hypothetically, type of flow can be determined by calculating the Reynolds number and simulating can be done directly by following the type of flow. But in this thesis, COMSOL simulation was performed before the calculation of Reynolds number for both the type of fluid flow. Later, the average value of the velocity from the simulation assisted to know the type of flow. The laminar average value obtained has a high difference with the experimental velocity. So, the type of flow cannot be laminar. The bar graph above also shows that the average velocity for the turbulent flow COMSOL simulation and experimental average velocity is approximately same. Hence, the flow type is demonstrated as turbulent. This is the engineering way of solving the problem. The above data helps to verify this statement.

Table 4: Tabulation of Experimental value and COMSOL Value for the calculation of head loss

	Inlet Velocity (m/s)	Outlet velocity (m/s)	Inlet pressure (kPa)	Outlet pressure (kPa)	Head loss (h_L) value using Bernoulli's equation (m)
COMSOL Value (turbulent)	0.53200	0.52627	230.44	224.00	0.65
Experimental Value	0.53200	0.53200	248.00	224.00	2.447

The comparison of head loss results in experimental method and the COMSOL simulation can be discussed. In case of experimental calculation of head loss, average velocity is used but the COMSOL simulation provides the different velocity and pressure at inlet and outlet. So, the different value of velocity and pressure has a direct impact on the head loss result in COMSOL method. It is the main reason behind the difference in the value of head loss between these cases.

Likewise, theoretical calculation for overall heat rate from heat transfer analysis was calculated 2554.74 W/m^2 in the same flow whereas heat transfer COMSOL simulation did not converge to give a solution.

The problem was aroused during the analysis of both the flow type in COMSOL while importing the model. The model of pipeline that was drawn in SolidWorks software goes indefinite computing. Later the model was drawn in COMSOL that simulation undergoes finding the result.

6 CONCLUSION

The Navier-Stokes equations are well modelled for fluid flow describes three different equations. They are momentum equation, energy equation and continuity equation. The Navier-Stokes equations can be simplified in some cases but in most of the cases like turbulence it is complicated in nature. Due to this, it creates various opinions on laboratory experiments.

The basic idea of this thesis is to use standard COMSOL for the observation of the flow of fluids in a pipe i.e. fluid flow module and to observe the heat transfer during the flow of fluids in a pipe i.e. heat transfer module and compare it with the results obtained in the laboratory. Hence, fluid flow was able to compare after the successful simulation but heat transfer did not converge to give a result.

The laboratory experiment was performed for the flow of fluid in pipe. The velocity was calculated with the help of flow rate and the obtained value was 0.532 m/s from the experiment for maximum pressure drop for the Arcada lab equipment. Later, the Reynolds number was calculated and the flow was found to be turbulent. The average turbulent velocity from the COMSOL simulation was found 0.529 m/s. These values of velocity found experimentally and COMSOL simulation is approximately the same.

Simulating fluid flow problem is computationally critical. Fine meshes are essential for the simulation of any kind of flow and many variables are required to solve it. If possible, a fast computer having many gigabytes RAM is fruitful for this kind of simulation as they required many hours or days longer for larger 3D models. Hence, it would be better to use as simple of a mesh as possible.

The new users can use these procedures as a guide in fluid flow for simulating the laminar, turbulent and heat transfer in the cylindrical pipe. SolidWorks is recommended as alternate software for the same type of analysis for the interested ones as it is advanced and popular software for this kind of analysis in the present world. The interested user can try to solve the heat transfer in fluid flow which did not converge to give a final result in this thesis.

Generally, mechanics and heat transfer problems are initially performed with analytical tools. Experimentally done such analysis cannot provide the accurate results but COM-SOL simulation yields almost accurate results. Fluid properties such as velocity and pressure in every part of the flow regime are impossible to know but the simulation produces a much more detailed set of results as compared to the experimental analysis and is often faster and less expensive.

REFERENCES

- [1] Introduction to the COMSOL analysis of fluid flow module and heat transfer module, assessed online on 02.10.2014, http://www.wpi.edu/Pubs/E-project/Available/E-project-081611-112631/unrestricted/MQP_Final_Report.pdf
- [2] Description on Navier-Stokes equations; primary theory behind the analysis, assessed online on 02.10.2014, http://www.wpi.edu/Pubs/E-project/Available/E-project-081611-112631/unrestricted/MQP_Final_Report.pdf
- [3] Objectives of the Simulation, short description about COMSOL, Fluid flow module, and Heat transfer module, assessed online on 03.10.2014, www.COMSOL.fi
- [4] Description in three different forms of energy, assessed online on 03.10.2014, <http://udel.edu/~inamdar/EGTE215/Pipeflow.pdf>
- [5] Description about Bernoulli's equation on the basis of laminar and turbulent flow, assessed online on 05.10.2014, http://udel.edu/~inamdar/EGTE215/Laminar_turbulent.pdf
- [6] Description on Laminar flow in fluid dynamics, assessed online on 10.10.2014, http://www.princeton.edu/~achaney/tmve/wiki100k/docs/Laminar_flow.html
- [7] Description on Turbulent flow in fluid dynamics, assessed online on 10.10.2014, http://www.efm.leeds.ac.uk/CIVE/CIVE1400/Section4/laminar_turbulent.htm
- [8] Reynolds number and relation with different types of fluid flow, assessed online on 11.10.2014, http://www.uio.no/studier/emner/matnat/math/MEK4450/h11/undervisningsmateriale/modul-5/Pipeflow_intro.pdf
- [9] H. Schlichting, K. Gersten (2003), eighth edition, Boundary-Layer Theory, chapter 9, description of dimensionless Prandtl number, page 210
- [10] Definition of Nusselt number, assessed online on 02.02.2015, <http://www.homepages.ucl.ac.uk/~ucecesf/tmp/heatandpipes.pdf>

- [11] F. P. Incropera et al. (2006).” Internal flow” in Fundamentals of heat and mass transfer, 6th edition, chapter 8, page 514, Nusselt number calculation in a fully developed turbulent flow in circular pipes.
- [12] Y.A. Çengel; J.M. Cimbala (2010), Fluid mechanics: fundamentals and applications, Chapter 8, Flow in Pipes, description about entrance region and figure, page 325
- [13] Y.A. Çengel; J.M. Cimbala (2010), Fluid mechanics: fundamentals and applications, Chapter 8, Flow in Pipes, description about entry length and figure, page 326.
- [14] Y.A. Çengel; J.M. Cimbala (2010), Fluid mechanics: fundamentals and applications, Chapter 8, Flow in Pipes, description about laminar and turbulent velocity profile and their respective figures, page 338
- [15] Y.A. Çengel; J.M. Cimbala (2010), Fluid mechanics: fundamentals and applications, Chapter 8, Flow in Pipes, pressure drop formula for laminar flow, page 329
- [16] Hagen-Poiseuille’s equation for the head loss calculation of laminar flow, retrieved online on 25.11.2014. http://udel.edu/~inamdar/EGTE215/Laminar_turbulent.pdf
- [17] Y.A. Çengel; J.M. Cimbala (2010), Fluid mechanics: fundamentals and applications, Chapter 8, Flow in Pipes, description about turbulent flows in pipe and figure, page 335.
- [18] Definition of Turbulent intensity and formula for the calculation, assessed online on 14.03.2016, http://www.cfd-online.com/Wiki/Turbulence_intensity
- [19] Definition of Turbulence length scale and formula for calculation, assessed online on 14.03.2016, http://www.cfd-online.com/Wiki/Turbulence_length_scale
- [20] Theory about the head loss in turbulent flow, assessed online on 05.11.2014, http://www.ecourses.ou.edu/cgi-bin/ebook.cgi?doc=&topic=fl&chap_sec=08.3&page=theory
- [21] Y.A. Çengel; J.M. Cimbala (2010), Fluid mechanics: fundamentals and applications, Chapter 8, Flow in Pipes, Darcy’s equation for the calculation of Head loss in fully developed circular pipe, page 330

- [22] Factors that affect head loss, assessed online on 06.11.2014, http://www.hydromatic.com/ResidentialPage_techinfopage_headloss.aspx
- [23] Description about turbulent shear stress and viscosity, assessed online on 17.09.2014, http://www.hydromatic.com/ResidentialPage_techinfopage_headloss.aspx
- [24] Y.A. Çengel; J.M. Cimbala (2010), Fluid mechanics: fundamentals and applications, Chapter 8, Flow in Pipes, Haaland Equation for the calculation of any surface roughness of pipe, page 341
- [25] Definition of friction factor and its correlated terms, assessed online on 16.03.2016 <http://www.thermopedia.com/content/789/>
- [26] Y.A. Çengel; J.M. Cimbala (2010), Fluid mechanics: fundamentals and applications, Chapter 8, Flow in Pipes, calculation of friction factor for laminar flow, page 330
- [27] Y.A. Çengel; J.M. Cimbala (2010), Fluid mechanics: fundamentals and applications, Chapter 8, Flow in Pipes, Friction factor calculation for turbulent flow by Colebrook equation, page 341
- [28] Description on Moody Diagram for the calculation of friction coefficient, assessed online on 25.09.2014, http://udel.edu/~inamdar/EGTE215/Laminar_turbulent.pdf
- [29] Figure of Moody Diagram for the calculation of friction factor, assessed online on 25.09.2014, http://www.engineeringtoolbox.com/moody-diagram-d_618.html
- [30] K.D. Jenson (2004), Flow measurement and measuring techniques, assessed online on 25.09.2014, <http://www.scielo.br/pdf/jbsmse/v26n4/a06v26n4>
- [31] Introduction to Volumetric flow rate, fluid flow equations, assessed online on 10.09.2014, http://www.engineersedge.com/fluid_flow/volumeetric_flow_rate.htm
- [32] Introduction to the mass flow rate, fluid flow equations, assessed online on 10.09.2014, http://www.engineersedge.com/fluid_flow/mass_flow_rate.htm

- [33] Y.A. Çengel; J.M. Cimbala (2010), Fluid mechanics: fundamentals and applications, Chapter 8, Flow in Pipes, Introduction to the velocity of a pipe flow, fluid mechanics, page 322
- [34] F. White, "Introduction" in Fluid Mechanics, 4th ed., J. Holman and J. Lloyd, Eds. McGraw-Hill Higher Education, 1998, pp. 47
- [35] J.H. Lienhard (2011), A Heat Transfer Textbook, Introduction to heat transfer, page 3
- [36] Figure of modes of heat transfer, assessed online on 18.02.2015, <http://www.roasterproject.com/2010/01/heat-transfer-the-basics/>
- [37] J.H. Lienhard (2011), A Heat Transfer Textbook, description of heat conduction on the basis of Fourier's law, page 10.
- [38] J.H. Lienhard (2011), A Heat Transfer Textbook, description of heat convection on the basis of Newton's law of cooling, page 20.
- [39] D.W. Mueller, heat transfer formulation for radiation, assessed online on 24.02.2015, http://www.etc.s.ipfw.edu/~mueller/heat_transfer.pdf
- [40] Conjugate heat transfer COMSOL blog (2014), assessed online on 17.11.2014, <http://www.COMSOL.fi/blogs/conjugate-heat-transfer/>
- [41] The figure regarding heat transfer in cross-section of a pipe, conjugate heat transfer, assessed online on 17.11.2014, http://www.cham.co.uk/phoenics/d_polis/d_enc/conjug.htm
- [42] F. P. Incropera et al. (2006). Fundamentals of heat and mass transfer, 6th edition, chapter 3, resistance diagram and its description regarding the heat transfer in pipes, page 116.
- [43] F. P. Incropera et al. (2006). Fundamentals of heat and mass transfer, 6th edition, chapter 3, final heat equation for the heat transfer in pipes, page 118.

[44] Roger W. Pryor (2001), Introduction on Multiphysics Modelling Using COMSOL; A First Principles Approach

[45] Highlights of COMSOL software, assessed online on 20.09.2014,
<http://www.COMSOL.fi/company>

[46] Multiphysics simulation with COMSOL, assessed online on 20.09.2014,
http://www.COMSOL.com/paper/download/200169/elshazly_paper.pdf

[47] Fluid flow COMSOL tutorial, Steady Incompressible flow, introduction and model definition, assessed online on 20.09.2014,
http://www.ewp.rpi.edu/hartford/users/papers/engr/ernesto/xiex4/ME_Project/Important%20Files/Reference/backstep_sbs.pdf

[48] Fluid flow COMSOL community discussion forum, inlet boundary conditions and the meaning of 's' in the property box, assessed online on 20.09.2014,
<http://www.COMSOL.com/community/forums/general/thread/17018>

[49] Fluid flow COMSOL tutorial, Steady Incompressible flow, meshing, study and post processing of the tutorial, assessed online on 20.09.2014,
http://www.ewp.rpi.edu/hartford/users/papers/engr/ernesto/xiex4/ME_Project/Important%20Files/Reference/backstep_sbs.pdf

[50] COMSOL setup for laminar flow module, assessed online on 03.01.2015,
http://www.wpi.edu/Pubs/E-project/Available/E-project-081611-112631/unrestricted/MQP_Final_Report.pdf

[51] Wilcox, David C (1998), "Turbulence Modelling for CFD", second edition, Anaheim: DCW Industries, 1998, page 174.

[52] COMSOL setup for turbulent flow module, assessed online on 03.01.2015,
http://www.wpi.edu/Pubs/E-project/Available/E-project-081611-112631/unrestricted/MQP_Final_Report.pdf

[53] COMSOL setup for heat transfer module, assessed online on 03.01.2015,
http://www.wpi.edu/Pubs/E-project/Available/E-project-081611-112631/unrestricted/MQP_Final_Report.pdf

[54] Table for the typical values of heat transfer coefficients, assessed online on 11.10.2015,
http://www.engineersedge.com/heat_transfer/convective_heat_transfer_coefficients_13378.htm

[55] [Data for minor loss coefficient on the basis of type of fittings or component, assessed online on 16.03.2016, http://www.engineeringtoolbox.com/minor-loss-coefficients-pipes-d_626.html](http://www.engineeringtoolbox.com/minor-loss-coefficients-pipes-d_626.html)

APPENDIX

The Turbulent flow analysis in pipe (COMSOL 5.1.0.136)

1. Open COMSOL → Click Model wizard → Select Physics → Fluid flow → Single phase flow → Turbulent flow → Turbulent flow, K-ε (spf) → Click Add → Click study → Select Stationary study → Click Done
2. Import Geometry or draw the geometry in COMSOL graphics with required unit of measurement.
3. In Material, select the required material. Water, liquid is used here.
4. In Turbulent flow Model Builder settings,
 - A fluid property is that of water.
 - In Initial values, velocity field should be placed according to the graphics drawn; here the figure is drawn in y-axis hence velocity is placed in y.
 - Pressure value is placed as 2×10^5 Pa as that of Arcada Laboratory.
 - Boundary condition in wall is “Wall Functions”
 - Inlet is added, velocity is placed; Turbulent intensity and turbulent length scale value was kept by the calculation i.e. Turbulent intensity (i_T) = $0.16 * Re_{dh}^{-1/8}$ and $(L_T) = 0.038 * d_h$.
 - Outlet is added, Pressure is placed; $224 * 10^3$ Pa.
5. Mesh is done, using user-controlled mesh.
6. Study is done by clicking **Compute**.
7. In **Results** toolbar, **Point Evaluation** is done in inlet and outlet of a pipeline.

	Turbulent		Laminar	
	Velocity (v) (m/s)	Pressure (kPa)	Velocity (v) (m/s)	Pressure (kPa)
Inlet	0.53200	230.44	0.22800	266.73
outlet	0.52627	224.00	0.00	224.12

8. In velocity section, **Max/Min Volume** is added to know the point of maximum and minimum value.

9. In Pressure section, **Contour** is added to view the different value of pressure in a pipeline.
10. Finally, **Report** is added to view the whole process during the simulation.

TABLES

Table 5: Typical values of heat transfer coefficient [54]

Flow type	(W/m ² K)
Forced convection; low speed flow of air over a surface	10
Forced convection; moderate speed flow of air over a surface	100
Forced convection; moderate speed cross- flow of air over a cylinder	200
Forced convection; moderate flow of water in a pipe	3000
Forced Convection; molten metals	2000 to 45000
Forced convection; boiling water in a pipe	50,000
Forced Convection - water and liquids	50 to 10000
Free Convection - gases and dry vapors	5 to 37
Free Convection - water and liquids	50 to 3000
Air	10 to 100
Free convection; vertical plate in air with 30°C temperature difference	5
Boiling Water	3.000 to 100.000
Water fowing in tubes	500 to 1200
Condensing Water Vapor	5.0 - 100.0
Water in free convection	100 to 1200
Oil in free convection	50 to 350
Gas flow on tubes and between tubes	10 to 350

Table 6: Tabulation of the results done experimentally

1	Flow Rate (\dot{V})	$1.67 * 10^{-4} \text{ m}^3/\text{s}$
2	Velocity (v_{avg})	0.532 m/s
3	Reynolds number (Re_D)	10618.76
4	Prandtl Number (Pr)	$1.046 * 10^{-2} \text{ W/m}^*\text{K}$
5	Nusselt Number (Nu)	$0.25 \text{ W/m}^2*\text{K}$
6	Internal diameter (D_i)	0.02 m
7	External diameter (D_o)	0.022 m
8	Water Temperature (T_{fluid})	313 K
9	Outside Pipe temperature (T_{body})	306 K
10	Heat Capacity of Water (c_p)	4186 J/kg*K
11	Thermal conductivity of laboratory pipe (k)	401 W/m*K
12	Overall Heat rate (q_r)	2554.74 W/m^2

Table 7: Minor loss coefficient according to the type of component or fitting [55]

Type of Component or Fitting	Minor Loss Coefficient - ξ -
Tee, Flanged, Dividing Line Flow	0.2
Tee, Threaded, Dividing Line Flow	0.9
Tee, Flanged, Dividing Branched Flow	1.0
Tee, Threaded, Dividing Branch Flow	2.0
Union, Threaded	0.08
Elbow, Flanged Regular 90°	0.3
Elbow, Threaded Regular 90°	1.5
Elbow, Threaded Regular 45°	0.4
Elbow, Flanged Long Radius 90°	0.2
Elbow, Threaded Long Radius 90°	0.7
Elbow, Flanged Long Radius 45°	0.2
Return Bend, Flanged 180°	0.2
Return Bend, Threaded 180°	1.5
Globe Valve, Fully Open	10
Angle Valve, Fully Open	2
Gate Valve, Fully Open	0.15
Gate Valve, 1/4 Closed	0.26
Gate Valve, 1/2 Closed	2.1
Gate Valve, 3/4 Closed	17
Swing Check Valve, Forward Flow	2
Ball Valve, Fully Open	0.05
Ball Valve, 1/3 Closed	5.5
Ball Valve, 2/3 Closed	200
Diaphragm Valve, Open	2.3
Diaphragm Valve, Half Open	4.3
Diaphragm Valve, 1/4 Open	21
Water meter	7