



**SAVONIA**

■ OPINNÄYTETYÖ - AMMATTIKORKEAKOULUTUTKINTO  
TEKNIIKAN JA LIIKENTEEN ALA

# NEW TECHNOLOGY AND OPTIMIZATION OF MOBILE PHONE BATTERY

Authors:      Liu Jian  
                    Zhang Yixian

|   |           |                  |    |
|---|-----------|------------------|----|
| Field of Study<br>Technology, Communication and Transport   |           |                  |    |
| Degree Programme<br>Degree Programme in Industrial Engineering and Management   |           |                  |    |
| Author(s)<br>Liu Jian; Zhang Yixian   |           |                  |    |
| Title of Thesis<br>New Technology and Optimization of Mobile Phone Battery  |           |                  |    |
| Date  | 19.5.2016 | Pages/Appendices | 35 |
| Supervisor(s)<br>Principal Lecturer Harri Heikura, Olli-Pekka Kähkönen  |           |                  |    |
| Client Organisation /Partners   |           |                  |    |
| <p>Abstract</p> <p>Mobile phone battery has faced three major bottlenecks. Poor battery life is the first hurdle, and then some the limitation of the fast charge mode, the last one is lithium principle limit, implying that material progress is slow. We see that lithium battery technology advances have indeed been great in this decade, but there is a lack of revolutionary change. There is no difference in the structure of Lithium batteries compared to the ones ten years ago, the main supporting material has remained substantially unchanged. Especially cathode material is still the same as 10 years ago which is lithium cobalt oxide, lithium manganese oxide, and lithium iron phosphate and ternary materials. Slow material progress also limits the further development of battery technology.</p> <p>The aim of the thesis was to study new mobile phone battery control and optimization. In this thesis, basic principle of first chapters is to discuss the condition of battery and its development, which includes the types of mobile phone batteries, the current problem with the existing ones and new batteries. The battery we used, what we are using and what we will see in the future. The problem includes safety and life of batteries and the operation habits of users.</p> <p>Then the new mobile phone battery technology and the battery's control and optimization are discussed. For example, quick charging has been used quite frequently. After that the market of the mobile phone battery is analyzed.</p> |           |                  |    |
| Keywords<br>Mobile Phone Battery, Quick Charging, New technology, Optimization  |           |                  |    |
|   |           |                  |    |

## CONTENTS

|       |   |    |
|-------|---|----|
| 1     | INTRODUCTION .....  | 5  |
| 2     | BACKGROUND .....  | 5  |
| 2.1   | The history of mobile phone battery .....                       | 5  |
| 2.1.1 | Early mobile phone's battery .....                              | 5  |
| 2.1.2 | Mobile phone battery evolved with phone .....                   | 6  |
| 2.1.3 | Nickel Cadmium Cell Phone Batteries .....                       | 7  |
| 2.1.4 | Nickel Metal Hydride Batteries .....                            | 7  |
| 2.1.5 | History of mobile phone battery charger .....                   | 7  |
| 2.2   | Current condition of mobile phone battery .....                 | 9  |
| 2.2.1 | Lithium Poly Ion Batteries .....                                | 9  |
| 2.2.2 | Lithium Polymer Batteries .....                                 | 9  |
| 2.2.3 | Current phone charger .....                                     | 10 |
| 3     | CURRENT PROBLEMS AND EXPECTATIONS OF MOBILE PHONE BATTERY ..... | 10 |
| 3.1   | Common misconceptions about mobile phone batteries .....        | 10 |
| 3.2   | Accident .....  | 12 |
| 3.3   | Environmental problems .....                                    | 12 |
| 3.4   | Expectations .....  | 13 |
| 4     | NEW TYPES OF BATTERIES .....                                    | 14 |
| 4.1   | Fuel cell .....   | 14 |
| 4.1.1 | Proton exchange membrane fuel cell .....                        | 15 |
| 4.1.2 | Direct Methanol Fuel Cell .....                                 | 15 |
| 4.2   | Aluminium ion Battery .....                                     | 16 |
| 4.3   | Graphene Battery .....  | 17 |
| 4.4   | Flexible battery .....  | 17 |
| 4.5   | Nano Tritium .....  | 18 |
| 5     | NEW TECHNOLOGY OF MOBILE PHONE BATTERY .....                    | 18 |
| 5.1   | Quick charging .....  | 18 |
| 5.1.1 | Lithium battery charging process .....                          | 19 |
| 5.1.2 | Quick charge principles .....                                   | 20 |
| 5.1.3 | Typical quick charge .....                                      | 20 |
| 5.2   | Wireless charging .....   | 22 |

|       |   |    |
|-------|---|----|
| 5.2.1 | Principle of Wireless charge .....                              | 22 |
| 5.2.2 | Wireless charging standards .....                               | 23 |
| 5.3   | High-capacity Li-ion Battery .....                              | 24 |
| 6     | THE MOBILE OPTIMIZATION AND CONTROLLING.....                    | 25 |
| 6.1   | Charging a Mobile phone battery .....                           | 25 |
| 6.1.1 | Operating and controlling of mobile phone charger circuit ..... | 25 |
| 6.1.2 | Improvement of mobile phone battery charging .....              | 26 |
| 6.2   | The optimization of the phone's components .....                | 27 |
| 6.2.1 | The optimization of CPU .....                                   | 27 |
| 6.2.2 | The Optimization of Screen.....                                 | 28 |
| 6.2.3 | The Optimization of Storage .....                               | 28 |
| 6.3   | The optimization of cell phone's system .....                   | 28 |
| 6.4   | Improvement of operating habits.....                            | 29 |
| 7     | MARKETS OF MOBILE PHONE BATTERY .....                           | 30 |
| 7.1   | Outlook of Mobile phone battery market.....                     | 30 |
| 7.2   | Factors Affecting Market.....                                   | 31 |
| 7.3   | Mobile phone battery manufacturers in China .....               | 31 |
| 8     | CONCLUSION.....   | 32 |
| 9     | REFERENCES .....  | 33 |

## 1 INTRODUCTION

Nowadays, we live in a society where people are dependent on their mobile phones. Almost everyone is using mobile phones, they have become an indispensable part of life. In 2015 there are more than 7 billion mobile cellular subscriptions worldwide, up from less than 1 billion in 2000.<sup>[1]</sup>

The battery is filled with electrolyte solution and a metal electrode to produce a current container. As an energy source when using a battery, it can be obtained with stable voltage, constant current, stable power supply for a long time. And the cell structure is simple, easy to carry, charge and discharge operation is simple, it is free from outside weather and temperature influence, with stable and reliable performance in modern social life. Those elements all play significant roles. Obviously, the battery is the critical part of a mobile phone, and Lithium-ion battery is the most common battery with a high energy density, tiny memory effect and low self-discharge whatever your mobile phone platform is, iOS from Apple, Android from Google or Windows Phone from Microsoft.

Actually, the technology of battery is still not so mature which causes all kinds of problems. In the course of frequent use, the use of mobile phone battery cannot reach our requirements. So we are mainly interested in increasing the capacity of the mobile phone, prolonging the service life of the battery and the application of new technology.

The purpose of writing the thesis is to study the development of mobile phone battery and the improvement of the battery, and it is aimed at finding more flexible ways to utilize of mobile phone's battery. It is also aimed at letting people pay more attention to the new battery technology and understand deeply, correcting people's wrong operating habits of mobile phone's battery. We were also interested in the application of new battery technologies in practice. We hope the new battery market will be better in the future.

## 2 BACKGROUND

The number of Mobile phones is growing rapidly, they have become an indispensable part of people's life. All sorts of problems will ensue. And battery is an integral part of the cell phone.

### 2.1 The history of mobile phone battery

It has developed less than one hundred years from the first mobile phone battery appeared to now.

#### 2.1.1 Early mobile phone's battery

Famous bell LABS of the US army made the world's first mobile phone "mobile phone". It means the first Hand-held radio transceivers available in the 1940s. They were all manual power driven or there was an external power supply.



FIGURE 1. The first Hand-held radio transceivers<sup>[2]</sup>

This mobile phone providing its own energy technique was used in the 1940s. That is a kind of development of old two-way radio technology. It was used in taxis and police cars and other service vehicles. The drivers, police or others could communicate with each other or connect with the people in central departments. The Swedish police used the first mobile phone connected to the telephone network in 1946. This phone was not as practical as nowadays, because car batteries would be drained after only making 6 phone calls. This first phone battery was connected directly to a car's battery for operation. At the beginning the phone was heavy and hard to carry. So it could only be used in the vehicle rather than carried on body because the duration of the mobile phone battery was very short at that time and needed more powerful battery. For instance, Eriksson had an 80 pounds mobile phone in the 1950s.

The modern mobile phones were tested in trials in Chicago, Washington D.C. and Baltimore in 1977 and in Japan in 1979<sup>[3]</sup>. These phones could only run and insist for 30 minutes without charging the mobile phone battery. However, this short-lived battery needed to be recharged for 10 hours. They were only used to make and receive calls. The mobile phone battery has a very big promotion, which was due to its small size, light weight and longtime power offering.

### 2.1.2 Mobile phone battery evolved with phone

The mobile phone became more and more popular in the 1980s. It was still mostly used in the car, because these early models of the phones had large demand for batteries. People called that was "car phone" for these devices at that time. And some were held in the package, which could also offer a large amount of mobile phone batteries. Mobile phones and batteries became smaller in the 1990s. There were GSM, TDMA and CDMA phone systems which came into existence. There were even digital phone networks in the US and Europe by 1991. Those phones were able to be carried which made moving easier, because the weight of batteries was between 100 and 200 grams.

### 2.1.3 Nickel Cadmium Cell Phone Batteries

Nickel cadmium battery consists of two plates, one is made of nickel, another is made of cadmium, both metals have reversible reaction in the cell, thus can recharge the battery.

Nokia introduced the first mobile phone Mobira Cityman in 1987<sup>[4]</sup>. The phone valued at thousands of dollars at that time. The battery could support less than ten hours. Nickel-cadmium batteries were almost occupying the entire phone's half of the weight and volume.

The advantages of nickel cadmium were that it is durable and the price is cheap, the disadvantages were that the battery capacity is small and life is short. So the nickel cadmium battery is the cheapest of batteries.

Nickel-cadmium batteries have a serious memory effect, the battery must be fully depleted once before recharging, and otherwise the battery will remember the shortened time, causing shorting of serious charge cycles. It could work even less than one hour. And after a long time calling, nickel-cadmium batteries will deform because of heat. Cadmium metal causes pollution to the environment, therefore there is a problem with disposal of after running out of battery. The market needed a new battery technology.

### 2.1.4 Nickel Metal Hydride Batteries

In 1989, after years of accumulation, nickel-metal hydride, otherwise known as NiMH, batteries started to be used in mobile phones. Nickel Metal Hydride battery had a lot more progress than nickel-cadmium batteries.<sup>[5]</sup>

Nickel metal hydride battery's capacity is 30% higher than that of nickel cadmium, manufacturing materials cause very little environmental pollution, people used to call it green cells. Voltage is 1.2 V. It is lighter, thinner, and non-toxic with greater energy density while the battery memory effect is greatly reduced. Although it still needed 20 times full charge and discharge, it represented very significant progress compared with before. However, the heat of the problem still existed and it still deformed.

### 2.1.5 History of mobile phone battery charger

There has been a mobile phone battery charger since a mobile phone. Charger is included in the purchase of a mobile phone. There are two original chargers, one is with the phone docked in direct charger, and the other is mounted battery charger.



FIGURE 2. Direct charger<sup>[6]</sup>



FIGURE 3. Universal Battery Charger<sup>[7]</sup>

Direct charger and Universal Battery Charger voltage requirements are not the same when charging. The output voltage of direct charger is 5V. Otherwise, the Universal Battery Charger is 4.2V. The charging current is generally 100mA-500mA. Charging output current is fast, on the contrary, charging would be slow. Due to the varieties of mobile phones, charging ports and battery sizes, the chargers can also be different. Once the charger is damaged or lost, it is difficult to buy one to match the charger, even if they can be matched, then the price is expensive. In view of this situation, after that there is a universal charger on the market.



FIGURE 4. Universal charger<sup>[8]</sup>

This charger is used to recharge cell phones of different sizes by adjusting the output power contacts with a clamp holding the battery in order to achieve the purpose. The charger also has several disadvantages. Each time when adjusting charging contacts, it is more difficult to get it to the right position. Even if contacted correctly with the battery, the contacts easily fall off. Due to fierce market competition, this also led to poor quality of this charger and it is very easy to break the battery. The phenomenon occurs when charging the battery, explosions also occurred.



According to the bad quality of the charger and resource wasting, the Chinese Ministry of Industry and Information Technology announced a new standard, "Technical Requirements and Test Method of Charger and Interface for Mobile Telecommunication Terminal Equipment"<sup>[9]</sup>.

## 2.2 Current condition of mobile phone battery

Under the efforts of people, new batteries have appeared constantly one by one. With the development of technology, the main focus and the most common cell phone batteries are lithium battery.

### 2.2.1 Lithium Poly Ion Batteries

The use of lithium-ion battery is a battery revolutionary milestone, which holds 40% more energy than the last generation battery. That is the newest addition to phone battery. In 1991, the lithium-ion battery became commercial for the first time, and performance improvement compared to previous battery was five times<sup>[10]</sup>. Without lithium-ion battery, the phone could not have been made from the huge "brick" to now developed pocket size version. It is super light actually, and there is no memory effect issue when charging. All the parts of the lithium-ion battery are safe to the phone device's environment. Mobile phones with lithium-ion batteries are mostly used, then standby time can often reach four to five days.

### 2.2.2 Lithium Polymer Batteries

It will never cease that people pursuit a longer duration, shorter charging time. In 2008, lithium polymer battery began appearing in people's field of vision. Due to the using of special technology when processing Lithium-ion batteries, the battery can be charged quickly within 2 hours and this greatly improved the safety performance. The lithium-ion battery's working temperature range is between - 20 °C to + 60 °C. Monomer of lithium ion battery voltage is 3.6 V, high quality lithium ion battery life can reach more than 1200 times. Batteries' life is long, far higher than other kinds of cells. It holds the largest capacity but the price is more expensive. There is high demand for phone battery charger. They need specialized charger. At present, most of the mobile phones with battery have a lithium battery.

Based on different electrolytic materials used in lithium-ion batteries, there are two kinds of batteries. One is lithium-ion battery and another is polymer lithium-ion battery. The main area is that different electrolytes, liquid lithium-ion battery use a liquid electrolyte, the polymer lithium-ion batteries uses solid polymer electrolyte. The polymers can be "dry" and "colloidal ". There is mostly polymer gel electrolyte currently.

The polymer lithium-ion battery can be divided into three categories:

- (1) Solid polymer electrolyte lithium-ion batteries. Electrolyte is mixture that is polymer mix with salts. At room temperature, the battery has low ionic conductivity, which is suitable for using at high temperatures.

- (2) Gel polymer electrolyte lithium ion batteries. That is added to the solid polymer electrolyte additive such as a plasticizer, thereby improving ionic conductivity, so that the battery can be used at room temperature.
- (3) Polymer as cathode materials for lithium-ion batteries. Using a conductive polymer as the cathode material, which is three times the energy of existing lithium-ion battery is the latest generation of lithium-ion batteries.

### 2.2.3 Current phone charger

- (1) Micro USB is the USB standardization organization Implementers Forum (USB - IF) introduced on January 4, 2007.
- (2) Apple's Lightning interface has three characteristics. The first is to reduce the volume, apple announced that the volume of a new interface decreased by 80%. On both sides of the second characteristic is the general, both positive and negative, and so can be convenient for the user. The third characteristic is easy to clean.
- (3) USB 3.1 Standard is the maximum data transfer speed of up to 10Gbit / s, Type-C interface socket terminal size is about 8.3mm × 2.5mm slim design. Supported from both sides and can be inserted with "reverse swap" function, without worrying about whether the anti-plug is inserted wrong, and can withstand 10,000 times repeated mating.
- (4) Wireless charging is a way that converting the power into rechargeable electric wave by a special device. And the battery can be charged without wires. Wireless charging is generally delivering energy through a magnetic field, and the efficiency of wireless charging is up to 70%.

## 3 CURRENT PROBLEMS AND EXPECTATIONS OF MOBILE PHONE BATTERY

Today's mobile phone battery technology is still not so mature, related problems always continue to happen. For instance, wrong ways of using mobile phone batteries and the environment problem. Based on it, the users hope it can be developed.

### 3.1 Common misconceptions about mobile phone batteries

When using the mobile phone battery, some problems are faced inevitably. But there are many mistakes in the internet which tell you how it should be used. Nowadays, almost all of the phone's battery is lithium-ion battery. So the following misconceptions are linked to lithium-ion battery.<sup>[11]</sup>

(1) Batteries have a memory

When we get a new phone, we used to train the battery in the ways of charging it after it is empty. We would often not to plug it in when it is over 50%. That idea is outdated that the battery would develop a memory and allow for just a percentage of the charge. Frequent charges will do no damage to your battery even it is over 80%.

(2) Off-brand chargers will damage your battery

They will not harm it, as long as the charger is adaptive and working properly. When choosing the charger, you should take one that standard of which is suitable for the batteries. Otherwise, don't believe the fast charger unless the device holds the function.

(3) Charging your phone overnight will damage your battery

In totally, the idea is not right. Now, the mobile phone will stop charging when the battery is filled. Of course it is not a good habit when charging. One is the waste of electricity, another is that will enhance wastage of your equipment.

(4) Don't use your phone while it charges

In fact, when charging the battery, even if you don't use the phone, it would still be working, for instance the chat application or the data transmission. But it is better not to make a call when you charging while the charging radiation is not healthy for you.

(5) Turning off your phone can damage your battery

On the contrary, appropriate shutdown can help battery to restore, is good for using. Also it can provide you better phone experience.

(6) You need to charge your phone to full before first using it

Actually Smart phone battery's best working state is from 40% to 80% power. We don't need to charge fully when we used for the first time.

(7) Putting your battery in the freezer will enlarge its life

It would not improve the battery life. There are even many adverse effects in cold environment. In fact, the battery's best working temperature is the normal room temperature level.

(8) Using the internet will drain the battery faster than anything else

Graphics engine is actually a huge dissipative system. So playing the game is the first consumption of power. But when you use the internet to watch videos or other activities by graphics engine, the battery will be run down faster.

(9) Task managers help prolong your battery life

The third-party task managers won't improve the battery life. But it can help you to manage your phone's application that you can enjoy a better operation experience.

### 3.2 Accident

To be honest, the cell phone battery is dangerous goods. We must have heard that news when someone's mobile phone was exploded. The most impressive one is that accident happened in the USA. With the help of a medium of the Internet and microblogging, this quickly became sensational news. It occurred on March 21st, 2012, when a woman from Colorado was waken by her iPhone 4, she found her mobile smoked, spit and made a little explosive noise. She wrapped it up with a computer bag into bathroom sink. Luckily she hadn't got hurt. According to the surveys, the main reason was that lithium-ion battery overheated.



FIGURE 5. The mobile after explosion<sup>[12]</sup>

### 3.3 Environmental problems

The intensified competition in mobile communication, higher capacity, and longer standby time will continue in pursuit to replace the old battery, update style, have more features, and better call quality of personalized mobile phone. And between the old and new alternatives, (due to the particularity of mobile phone batteries, a certain type of battery only fits with a certain type of machine) will have tens of millions of old cell phone batteries.

In general, Li-ion batteries are classified as non-hazardous waste because they contain less toxic metals than other types of batteries which may contain lead or cadmium. There are iron, copper, nickel and cobalt in lithium-ion batteries. These metals are regarded as safety for incinerators and landfills and can be recycled. Nowadays, there are not so much investment in recycling of Li-ion batteries because of costs, complexities and low yield. Also recycling is generally more expensive than

the mining. Lithium is less expensive than other metals used, but recycling could prevent a future shortage.<sup>[13]</sup>

### 3.4 Expectations

At the end of 2015, technology website PhoneArena had taken a vote for the most expectation of 2016 mobile technology improvement. If it were up to you, what would you have manufacturers focus on in 2016?

As the figure 6 shows, the number of users who hope battery life improved in the coming year is as high as 63.7%, and the second user experience is only 16.17% of the vote, other aspects of the vote are much rarer.

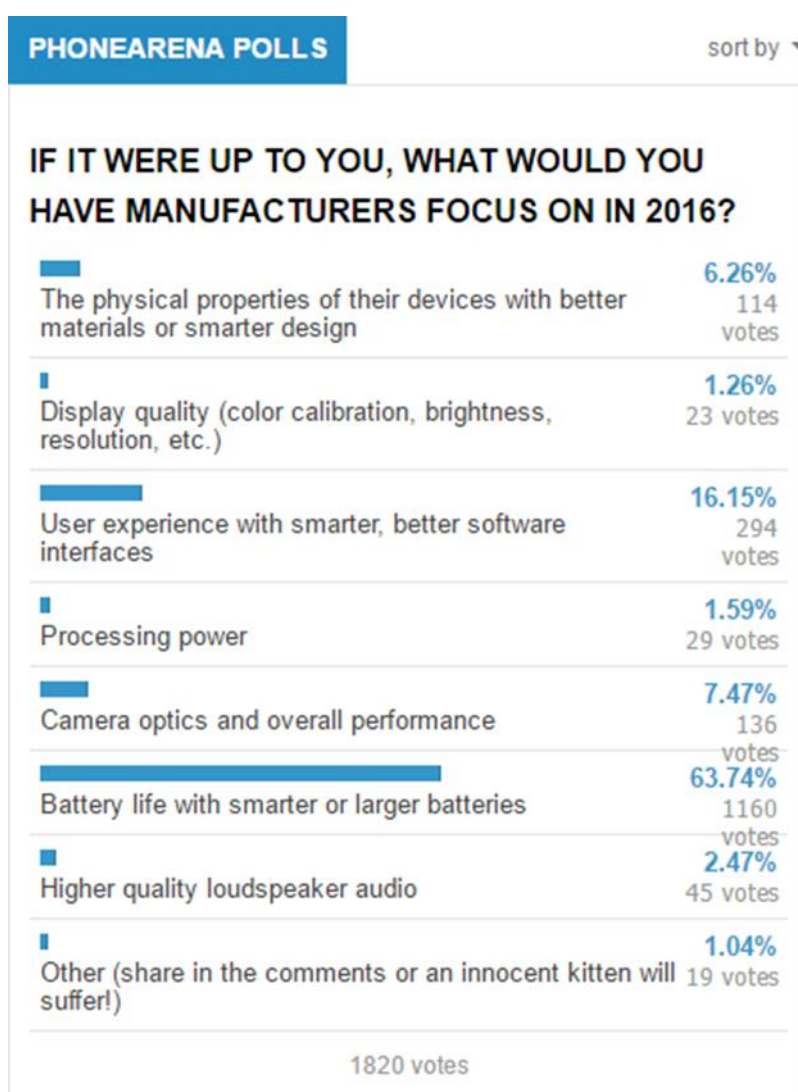

FIGURE 6. The results for voting<sup>[14]</sup>

Anyway, the capacity of mobile phone battery always needs to be improved. Especially in the time of smart phone, phone battery is always a problem. We want to charge it anytime and anywhere. So prolonging the ability of battery and improving the use efficiency is the most anticipated thing.

## 4 NEW TYPES OF BATTERIES

Now phone is more and more intelligent, lithium battery couldn't catch up with the development of the mobile phone schedule. People are not content with the current lithium-ion batteries, hope to create a new battery. With the passing of time, the new technology and new concept are already more and more popular to people.

### 4.1 Fuel cell

British energy technology developer Intelligent Energy announced that they have made a major breakthrough in the world's first smart phone hydrogen fuel cell technology, which said it had assembled its own hydrogen fuel cell into an iPhone 6. The battery life can reach a full 7 days' time without changing the shape and size of the iPhone. Then everything operates normally. However, because the battery is generated by the reaction of hydrogen and oxygen, it will produce a little bit of water and heat, as long as the holes allow water vapor to drain back immediately. In general we do not feel this is completely physical change.



FIGURE 7. The fuel was used in iPhone 6<sup>[15]</sup>

Swedish innovation company MYFC has created a kind of mini power plant which is fuel cell charger with USB.

It can be used when you add any available water in emergency. The devices, producing hydrogen gas that powers the fuel cell, generates power by mixing sodium silicide with the water. It can provide almost 10 hours as four AA batteries.

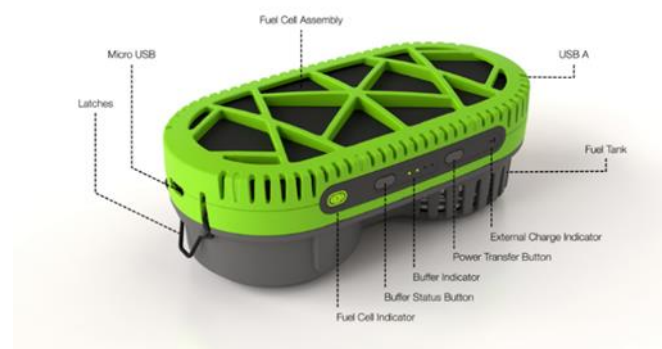

FIGURE 8. Stockholm techies use water to charge mobile phones<sup>[16]</sup>

#### 4.1.1 Proton exchange membrane fuel cell

When the battery is used, first hydrogen will be sent to the fuel cell anode plate (anode) through the role of a catalyst (platinum). Then the hydrogen atoms of an electron are separated, losing electrons hydrogen ions (protons) to pass through the proton exchange film and reaching the fuel cell cathode plate (positive electrode). The external electronic circuit board to the fuel cell cathode, thus generating a current in the external circuit, the electrons reach the cathode plate after an oxygen atom and hydrogen ions recombine to water.

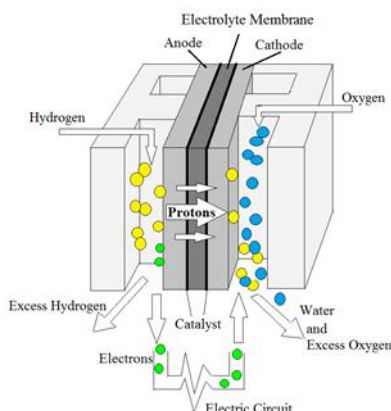

FIGURE 9. How a fuel cell works<sup>[17]</sup>

#### 4.1.2 Direct Methanol Fuel Cell

Direct Methanol fuel cell's methanol flows into the anode and reacts with the and hydroxyl ions produced in cathode. The result is carbon dioxide and water, among the rest the hydrogen atoms in the molecule of methanol to produce water (H<sub>2</sub>O), generating carbon dioxide (CO<sub>2</sub>). On the other hand, oxygen is used in cathode, the metal catalysts are ruthenium, rhenium, molybdenum, tungsten and other precious metals or transition metal. Due to the simple structure of battery and requiring a very short time from start to stabilize power generation, coupled with high stability, low operating temperature, convenient refueling. This kind of battery is currently the only widely used in a variety of mobile electronic products, vehicles. However the only disadvantage is that fuel cell energy conversion efficiency is low currently around 30%. In addition, scientists use nano-catalyst to produce this fuel cell into a small volume. "Micro fuel cells" can be used in mobile phones, PDA, notebook com-

puters and other handheld electronic products. The number of energy density is ten times higher than in lithium batteries, you can make phone standby for more than 100 days, but the higher cost nano catalyst, and a proton exchange membrane prices are high, there are still difficulties in commercialization.

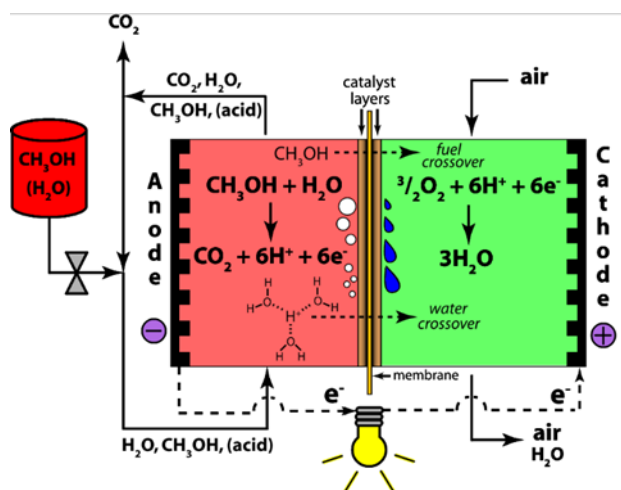

FIGURE 10. Direct Methanol Fuel Cell Methanol and Water Crossover<sup>[18]</sup>

US Energy Related Devices companies and Manhattan Scientifics Company AGL open up the mobile phone market with a fuel cell. The two companies' prototype's fuel cell is half the volume of a matchbox. When injected into the methanol fuel 42g, the mobile phone talk time is 100h, standby time up to 41d<sup>[19]</sup>. Due to the fact that small fuel cell is used together with the semiconductor integrated circuit, the system structure is subjected to special constraints. In the portable electronic device in the application of fuel cells, high-density assembly must be used. The most prominent member of the system structure, called an electrolyte membrane and electrode structure is integrated. It allows convenient scale manufacturing of a flat type fuel cell stack.

#### 4.2 Aluminium ion Battery

Hu Nan University and Stanford University have just developed a new battery when the battery is fully charged only takes a minute and it is safer than lithium-ion battery<sup>[20]</sup>. Anode material is graphite, and salt solution with an equivalent ionic liquid as the electrolyte, aluminium cell research has solved the bottleneck of the material. It was found that the three-dimensional graphite as a battery cathode material can greatly shorten the battery charging time. In addition, the high-performance battery is difficult to catch fire or explosion. According to the study, the new battery can be recharged 7500 times and maintain performance. Normal cycle life of lithium is generally 300 times, while the experiments show that the aluminium battery cycle is 7500 times, the capacity with little attenuation, which is equivalent to charging twice a day, 20 years later battery usage is still as at the beginning. Lithium battery production costs will be lower, and electrolysis of ionic liquid non-toxic provides environmental advantages. In the future, the aluminum battery not only can be used in mobile phones and other small appliances, but also in electric vehicles and other violent collision



prone areas and high temperatures replace the current batteries. Because it is safe, long life and quick charging.

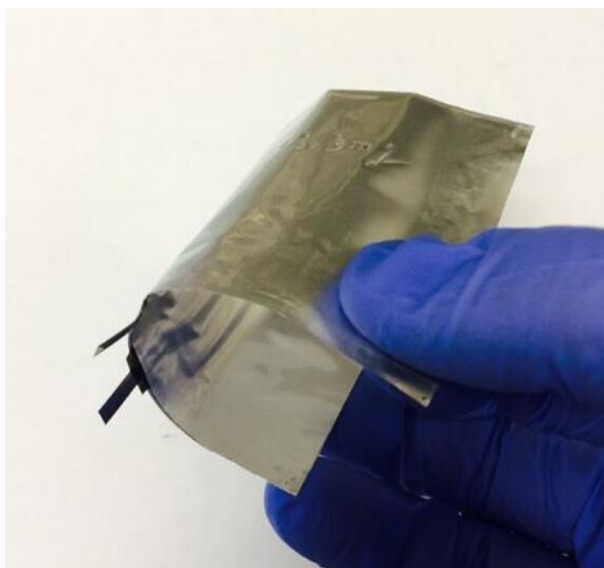

FIGURE 11. New type of Aluminium ion Battery<sup>[21]</sup>

#### 4.3 Graphene Battery

An innovative graphene battery is in the traditional cell phone lithium battery added to graphene composite conductive powder to increase the magnification of the battery charge and discharge performance and cycle life.

Conductive properties of graphene are very good. With the conductive carbon black to join the electrode film, sheet resistance can be reduced, making the phone battery faster charging and providing longer life. "After the phone battery using graphene technology, the charging rate is increased by 40%, to extend life expectancy by 50%<sup>[22]</sup>."

At the same time, because of the flexibility of the graphene, pressing graphene can improve battery capacity. In the case of the same volume graphene battery energy density than conventional batteries can be increased by 10%, so that the phone's standby time can be increased.

#### 4.4 Flexible battery

Arizona State University research team has come up with a flexible battery. This result shows that the smart watch can be used with flexible longer battery life and smaller versions.

Although the scientists have succeeded in driving a Samsung gear 2 with a flexible battery, it is a little bigger than the initial prototype battery would be, which means that it is less flexible. <sup>[23]</sup>It is flexible enough to move from wrist to biceps and bending movement, while still powering the smartwatch. This type battery is safety, there is no explosion or leaking even it is broken. If the mobile phone is equipped with the flexible battery, it would be amazing.

## 4.5 Nano Tritium

The NanoTritium is a thumb-sized battery that draws on the energy released from its radioactive element to provide continuous NanoWatt power.

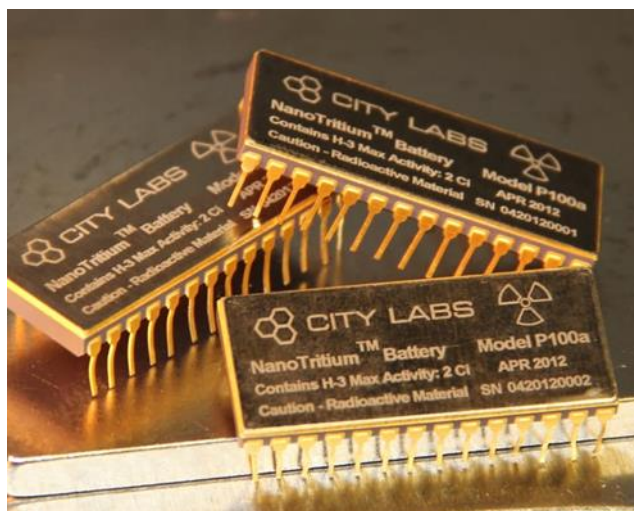

FIGURE 12. 20-year battery life of tritium<sup>[24]</sup>

Tritium battery biggest features are long life, ultra-compression seismic capacity, and superior resistance to low temperature high temperature capability. Its life is up to 20 years, this type of battery is able to withstand a temperature range from minus 50 degrees Celsius to 150 degrees Celsius. It can work in extreme temperature environment and altitude without pressure. The world's first battery Nano Tritium has been successfully developed by the Florida City Labs laboratory.

Priced at \$ 1,000, the current tritium battery voltage is 2.4V, the current 50 ~ 350 nA, power up to only 840 nW.

## 5 NEW TECHNOLOGY OF MOBILE PHONE BATTERY

We all know that the battery technology won't be changed immediately, but all of the concerned technicians are trying to break down those technological puzzles. Here is some new technology about mobile battery.

### 5.1 Quick charging

For smartphone users, whether the charging is convenient or not is also the consumer concerned. In addition to mobile phone manufacturers thinking about how to reduce the power consumption of the phone from hardware and software aspects, the built-in wireless charging and fast charging of mobile phones has become more and more important, in recent years the popularity of fast charging speed has been quite fast. Because from the phone's function with built-in quick charge, the user can clearly feel not only shorter charging time, but also almost no adjustment of the original usage.

### 5.1.1 Lithium battery charging process

All the quick charging functions are based on Lithium battery, so firstly the essential Lithium battery charging process will be introduced. In the figure 13, abscissa for time, ordinate for lithium battery voltage. Due to the particularity of lithium batteries, over voltage or under voltage will cause the battery breaking down, so now the lithium battery charge and discharge protection circuit principle is measurement of lithium battery voltage.

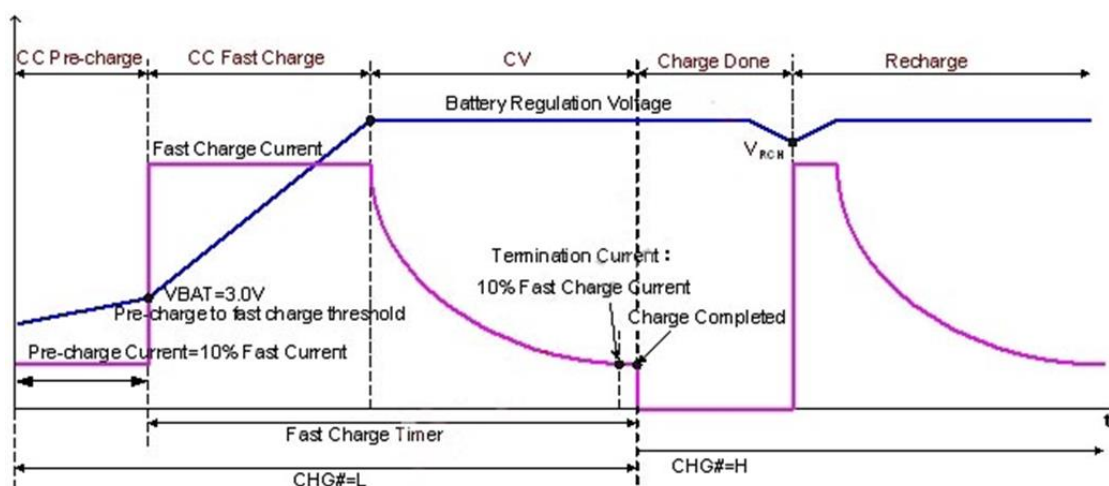

FIGURE 13. Lithium battery charging process<sup>[25]</sup>

Lithium battery charging current is as shown in the above pink line. Lithium battery charge is divided into three stages, respectively there are constant current charging, large constant current charging and constant voltage charging.

When the voltage is lower than 3.0 V, the charger will use 1/10 setting current for lithium battery charging when it is above the CC Pre - at stage, purpose is slowly recovering discharge of the lithium battery, this is a kind of protection measure. Qualified charger will have this stage.

When lithium battery voltage is higher than 3.0 V, it enters the second stage, the large constant current charging stage. The charging current can increase appropriately, depending on the battery, the size of the current can range from 0.2C to a few C, which the C means the battery capacity, as 2600mAh lithium battery, 0.1C means 260mA current size.

And the last stage in recharging is constant voltage charging phase, in which it is detected that when the lithium battery voltage is equal to 4.2V, the charger enters constant-voltage mode. This stage is a constant charging voltage 4.2V, the charging current is getting smaller and smaller. When the charging current is less than 1/10 setting current, it is determined that the battery is full, cut off the charging circuit.

### 5.1.2 Quick charge principles

We all know this basic formula :

$$P = U * I \quad (1)$$

Where:

$U$  is output voltage(V)

$I$  is output current(A)

Under the condition of guaranteeing that the charger voltage is higher than the battery voltage, quick charge is according to dynamic parameters, such as the battery voltage, power, and even temperature, to let charger in real time adjust to the input voltage, output current. It is specifically divided into three ways as follow.

- (1) The boost voltage, constant current: In this way large amounts of heat are produced, power consumption is increased, and the battery and mobile phone would have damaged.
- (2) Constant voltage, current promotion: When shunt in the parallel circuits, each pressure of circuit decreases.
- (3) Increasing the voltage and current, although this is the best way to increase charging speed. But the same as the first point, at the same time increase of the voltage and current will produce more heat, so as to increase consumption of the battery and the device itself.

### 5.1.3 Typical quick charge

#### Qualcomm Quick Charge

Chip giant Qualcomm Company has developed a technology called Quick Charge, the 3.0 version is already.

|                  | Quick Charge 3.0                       | Quick Charge 2.0  | Quick Charge 1.0 |
|------------------|--|---|------------------|
| <b>Voltages</b>  | 3.2v - 20v dynamic                     | 5V / 9V/ 12V  | 5V               |
| <b>Max Power</b> | 18W                                    | 18W   | 10W              |
| <b>SoCs</b>      | Snapdragon 820, 620, 618, 617, and 430 | Snapdragon 200, 400, 410, 615, 800, 801, 805, 808 and 810 | Snapdragon 600   |

FIGURE 14. Charging values between each of Qualcomm's Quick Charge revisions<sup>[26]</sup>

The figure 14 shows that vision 3.0 provides more range of voltage to allow the better efficiency of fast charging. New standards use the call "Intelligent Negotiation for Optimum Voltage" (INOV) algorithm, let the mobile phones continue to ask the charger voltage level, ranging from 3.6 V to 20 V,

the interval of each is 200 mV. In contrast, the Quick Charge 2.0 only provides 3 charging voltages, but 3.0 provide 82 different voltage levels. It will "minimize the loss, increase efficiency, and at the same time improve the thermal performance".

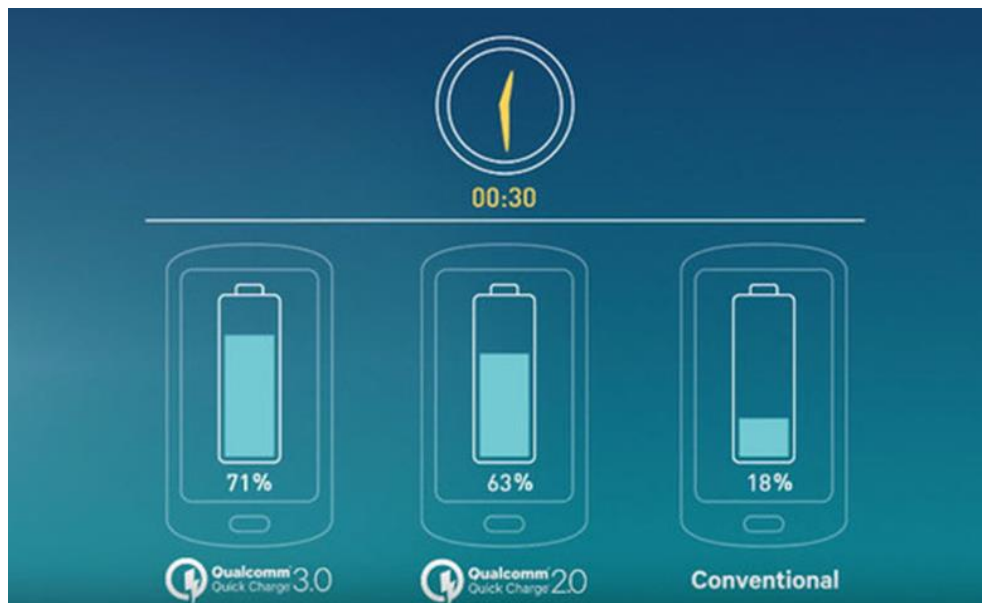

FIGURE 15. Charging in 30 minutes<sup>[27]</sup>

The Quick Charge 3.0 provides for compatibility versions 1.0 and 2.0, independent of the connector type at the same time. Of course, users need a new mobile phone and chargers to enjoy the advantages of this standard. Qualcomm expects the technology will start gradually spreading from this year. The limitation of the technology is the chip, which are qualcomm technical barriers. Although Snapdragon 200 is also supported, but not qualcomm chip, such as Samsung Exynos, Huawei haisi, as well as MTK6595 can't be supported.

#### VOOC Flash Charge

The idea of OPPO fast charge is clearly more radical. It is used in low-voltage and high current, such as Find 7 is equipped with a 5V voltage + 5A current charging mode, 30 minutes probably charged 75% of the electricity.



FIGURE 16. OPPO batteries<sup>[28]</sup>

VOOC flash charging system hardware's distinctive design is 7-pin micro USB port and eight metal contacts in the battery. In general, the conventional micro USB 5-pin interface, and mobile phone battery have 4-5 contacts, but OPPO Find 7 has a 7-pin, 8-contact. The extra pins and contacts can be formed similar to multiple batteries in series channel, so as to enhance the charging speed.

Since VOOC flash charging technology is not the platform technology, currently only supports OP-PO's own products, such as OPPO Find 7, N3, R7, and should be used with flash Charger, it has greater limitations.

## 5.2 Wireless charging

Although the wireless charging technology has been widespread concerned in recent years, it has still not yet gained popularity in the field of consumer electronics. In fact, electric vehicles and intelligent households have become increasingly popular, it is not hard to imagine wireless charging technology will play a vital role in the future.

### 5.2.1 Principle of Wireless charge

There are three principles of wireless charge which are electromagnetic induction charging, magnetic resonance charging and radio waves charging.

Electromagnetic induction charging is mainly two parts, one is the electromagnetic induction, and another is inductive electromotive force. The main principle of the law of electromagnetic induction is part of a closed circuit in a magnetic field generating an induced electromotive force. When cutting magnetic induction line movement, then the induced electromotive force can drive electrons form current. By this principle we offer the coil a changing magnetic flux. Within the coil current is generated, then this part of the current is integrated into DC current to charge the phone battery.

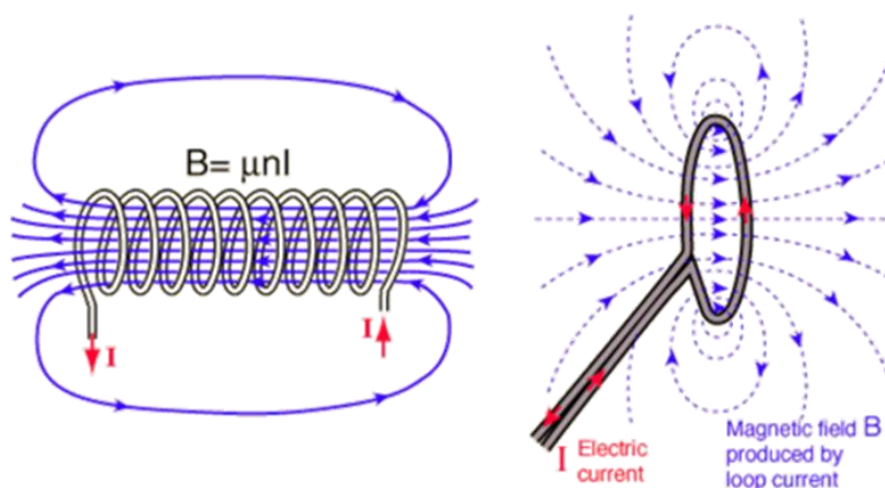

FIGURE 17. An example of electromagnetic fields produced by a solenoid and loop of wire<sup>[29]</sup>

Magnetic resonance charging consists of the energy transmission device and the energy receiving device. When the two devices are adjusted to the same frequency, or at a particular resonant frequency, they exchange energy with each other.

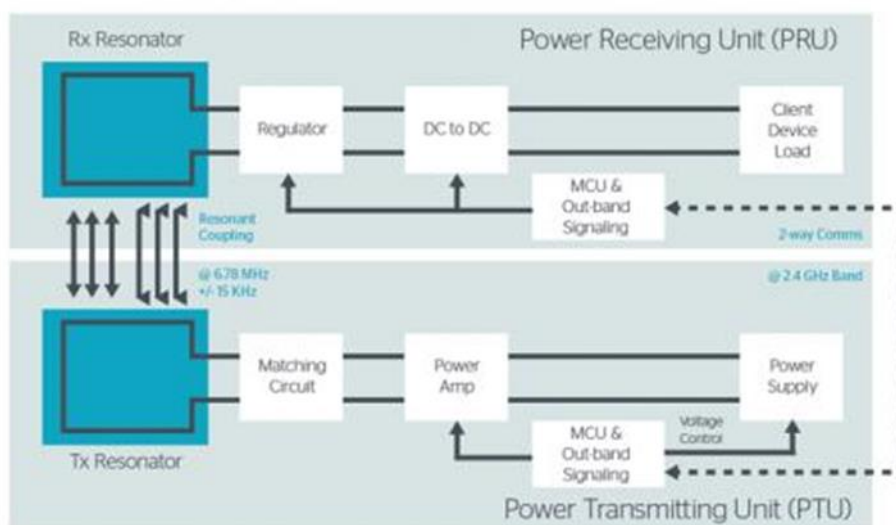

FIGURE 18. Resonance block diagram (source: A4WP)<sup>[30]</sup>

Radio waves charging mainly includes a microwave transmitting device and a receiving device. You can capture energy from the radio waves bouncing off the walls, with the load at the same time making adjustments to maintain a stable DC Voltage.

### 5.2.2 Wireless charging standards

Compared with fast charging, wireless charging technology subverts the traditional charging mode. There are now three major international wireless charging standards: WPC Qi standard, Duracell Powermat PMA standards and A4WP standard by Qualcomm, Samsung and Powermat together. Today A4WP standard and PMA standards have been merged.



FIGURE 19. Qi wireless charge<sup>[31]</sup>

Qi standard is the world's first organization to promote standardization of wireless charging technology. It was launched the Wireless Charging Consortium (WPC). It adopted the most mainstream electromagnetic induction technology, has the compatibility and commonality characteristics. As long as it is with Qi logo products, Qi wireless charger can be used.

On the issue of improving the efficiency of energy transmission, A4WP solution and Qi are completely different. Compared with Qi, A4WP adopted a bigger output coil and it can at the same time charge for multiple devices. Due to setting a precise resonant frequency at the same time, even the weak inductive magnetic field can also charge equipment, which means that the charging A4WP range will be much bigger than that of the Qi.

### 5.3 High-capacity Li-ion Battery

Hitachi uses a newly developed and silicon-based material to constitute the negative electrode of the battery, which can double the density of the battery. Hitachi has showed the technologies about producing the lithium batteries on Tokyo Second Wearable Fair (Wearable Expo), held from January 13 to 15, 2016.





FIGURE 20. Lithium-Ion Battery (Medium-sized)<sup>[32]</sup>

Maxell's original technologies, such as electrode technology, have realized thin batteries with high capacity that can be used in compact high-performance mobile devices.

## 6 THE MOBILE OPTIMIZATION AND CONTROLLING

People want to get a better experience. Therefore the mobile phone battery has to be controlled and optimized to a certain extent. When cell phone battery life is longer, people will get rid of a lot of trouble.

### 6.1 Charging a Mobile phone battery

Battery has to be charged at least once a day for people who have a mobile phone. Thus, charging is very important. How to improve and control the charging is also an issue for people concerned.

#### 6.1.1 Operating and controlling of mobile phone charger circuit

Circuit is very simple, it is a small switch with power supply. The switch triode is the easiest part to break down. And this is a cheap type charger.

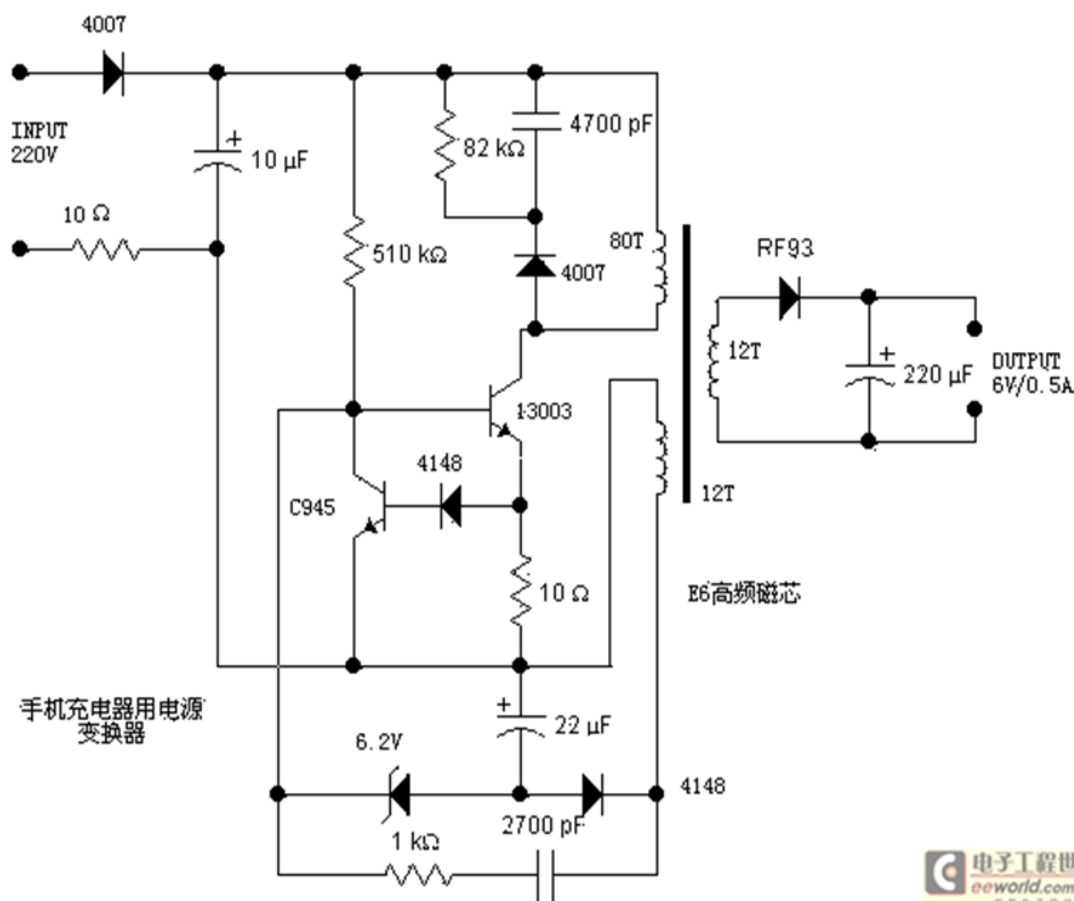

FIGURE 21. Normal Mobile Phone Charge Circuit<sup>[33]</sup>

This circuit can adjust voltage stably and limit current. The 10-ohm resistor is used for protection. If the latter over flow or broken, then the resistance will be burnout, and thus a bigger failure is avoided.

High-voltage absorption circuit consists of the right half-wave rectifier 4007, capacitances 4700pF and resistor 82KΩ. This circuit is responsible for preventing the switch 13003 getting high voltage when the switch 13003 is turned off. The switch MJE13003 can withstand 400V, maximum current loading up to 1.5A. When the 10-ohm resistor voltage is higher than 1.4V, then transistor C945 is turned on, so that the voltage of switch 13003 will be reduced. The limited current prevents switch from burning because of overcurrent. The induced voltage of windings under left bottom transformer, which is rectified by rectifier diode 4148 and filtered by capacitor 22uF, becomes sampling voltage. It can generate steady output voltage by controlling increasing the voltage in the right of secondary winding.

### 6.1.2 Improvement of mobile phone battery charging

Built-in power management ICs PMIC, allow charger charging decisions based on the current needs of the initial voltage, then the current command PMIC pulsing through the USB Vbus (USB voltage) to the charger, follow the instructions to regulate the output voltage, the voltage maximum charging current increases eventually 5V.

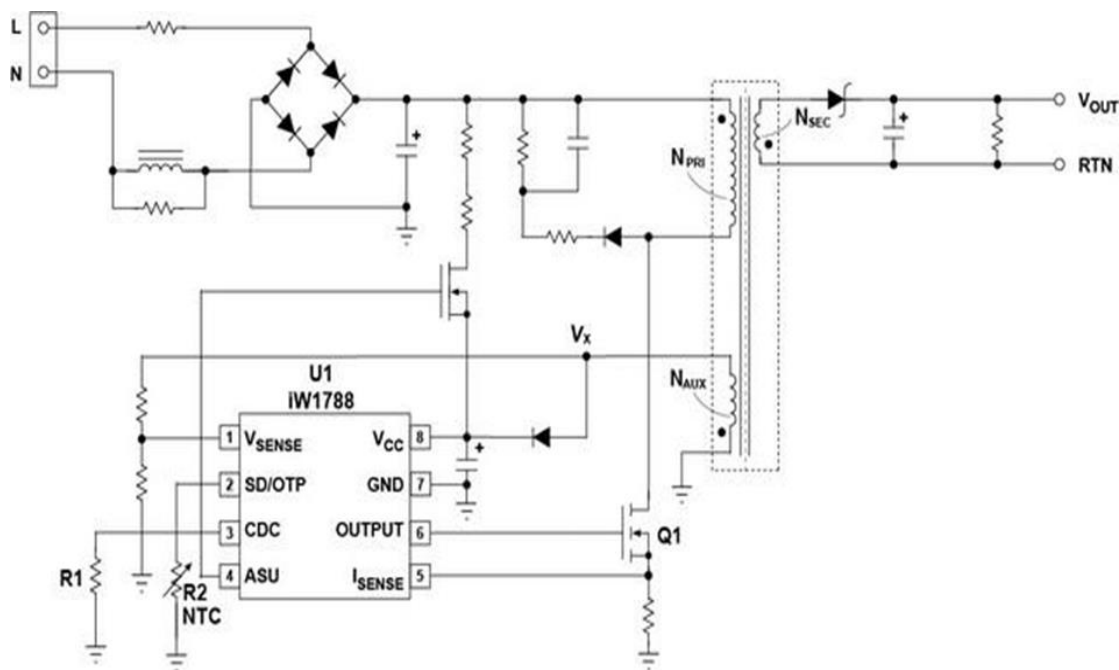

FIGURE 22. Quick Mobile Phone Charging Circuit<sup>[34]</sup>

Voltage and current from Nsec to Naux composition reverse the transformer fluctuations. The output current Naux gave Vsense pin, Vsense circuit calculates the current changes, then increasing the voltage of Npri transformer. After that the output of the secondary coil Nsec voltage is also increased. According to the formula  $P = UI$ , the power is increased when exporting to cell phone charger, IC (integrated circuit) increases. It ensures that when the battery voltage is close to 4.2V, constant adjustment is performed from  $P = UI$  (5V × low current) to  $P = UI$  (greater than 5V low voltage × current). This achieves quick charging of the battery. And another one is the 7-pin micro USB port and 8-contact Battery.

## 6.2 The optimization of the phone's components

The capacity of the battery can't be a breakthrough in short time, people are concerned with other aspects of improvement. Better internal components can reduce the consumption of electricity.

### 6.2.1 The optimization of CPU

A common way for many companies is to use "big.LITTLE CPU" structures which were developed by ARM to improve the performance of the chip and reduce or maintain power the core. They combined the core of high-performance and low power consumption to select the best processor for each program for reaching balance between performance and power consumption. Samsung's latest Exynos 8890 is combined four self-developed high-performance cores with "big.LITTLE CPU" structures Mongoose which was four public version A53.

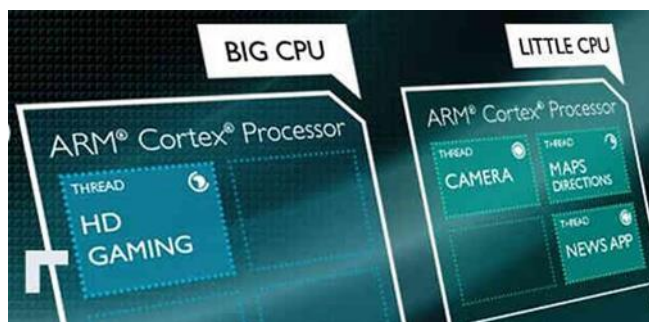

FIGURE 23. Big.LITTLE CPU<sup>[35]</sup>

MediaTek released that Helio X20 has developed further the concept of “big. LITTLE CPU” to new structure of Tri-Cluster three clusters with 2 + 4 + 4 all 10 core design. This kind of design accommodated more usage scenarios and improved efficiency, which is very similar to the car high and low gear design. Although the size of the structure Qualcomm Snapdragon 820 is not “big. Little CPU” in the strict sense, four major core Kryo was divided into different sizes in frequency to achieve low power consumption and performance improvement. And the new one was joined with the Hexagon 680 DSP to reduce the burden on the CPU. In addition to optimization of the structure, increasing process technology of SoC is also the main factor reducing the power consumption. Transistor structure has evolved from 28 nm, 20 nm to 16 nm even 14 nm, which is developed from 2 d to 3 d FinFET process. The new technology improves significantly the circuit control and reduces the leakage current, making the processor save more electricity.

### 6.2.2 The Optimization of Screen

Of course, in addition to SoC, the consumption of the big screen is also very high. Major suppliers developed a variety of new technologies to reduce power consumption, for example, the most energy saving AMOLED screen, which does not require a backlight material also contributed to the popularity of Always On Display.

### 6.2.3 The Optimization of Storage

In storage, the new LPDDR4 memory specification of 1.1V voltage drop compared to the past LPDDR3 a 0.1V; UFS 2.0 flash memory eMMC 5.0 faster performance than 87%, mean to completing the same task takes less, save power and thus plays an important role.

## 6.3 The optimization of cell phone's system

Many mobile phone manufacturers have developed a new operating system for the battery improvements. Improvement of the operating system also has a lot improvement on manufacturers selling competitiveness. More simple and convenient operating systems will be more suitable for people. There are some practical operations as follows.

#### (1) Adjusting the screen brightness

The consumption of screen is very high, according to the current ambient light the system defaults to adapt automatically. So, then you can turn off the screen adjusting the screen automatically, then adjusting the brightness of the screen to an appropriate location for saving power.

#### (2) Turning off Bluetooth

It was found that when iPhone users get the first boot, the phone's Bluetooth is turned on by default. After updating a system, phone will turn on the Bluetooth automatically. Although the consumption of Bluetooth may be just a small part of the power, it is not needed used.

#### (3) Reducing application background refresh

Most people like switching back and forth between different applications constantly, but less people know too many applications running in the background is a huge demand. It can be set closed in the background in most applications refresh. This situation happened particularly in the Facebook application background refresh, with really high consumption. Reloading that is a more effective method of saving each time you want to use it.

#### (4) Turning off location services

GPS positioning chips can be obtained targeting parameters where we are presently, then you can map server through the network and combined display specific location currently resides. This feature is very useful for us at the moment, but its consumption of electricity is large.

#### (5) Intelligent power saving

A good software can closed daemon intelligently. There are some options for you to operate just IOS 9, which is battery saving mode. Using the power-saving mode the system will reduce the consumption of battery. Another one is alerting users smart to maintain the battery.

### 6.4 Improvement of operating habits

The best option for saving power is developing habits. Do not wait to charge until completely discharged and do not over-charge for long hours. Another one is trying to use less while charging the phone.

It may hurt people and battery when receiving calls and doing other operations at the same time while charging. Because phone's battery voltage would be many times higher than usual. Secondly, while charging the phone, radiation is also higher than usual. Furthermore, people should use the original charger that is usually with output voltage DC + 5V, output current of 1A. There is important significance for the protection of the battery and safety.

## 7 MARKETS OF MOBILE PHONE BATTERY

There is a huge market for mobile phone battery. With the increase of mobile phone functions, consumption of batteries will inevitably increase in the future. A huge cell phone market has taken shape. In recent years, when reviewing the development history of mobile phone batteries, we can find that no vendor stands out. This is a highly competitive market, while traditional mobile phone batteries in the field in recent years have had no technological breakthroughs and innovation, the only way is multi-brand operation for mobile phone battery manufacturers as much as possible to occupy the market. Research and development of technology determine the position in the market. The solutions about high-capacity and quick charging mobile phone battery in this market are the most competitive hot spots currently.

### 7.1 Outlook of Mobile phone battery market

In recent of years, the smartphone has become more and more popular. The smartphone plays an important role in our daily life during the intelligent era. In 2014, the smartphone users was up to about 1.6 billion. In the next few years, the smartphone users will increase steadily as we can see from the figure 24.

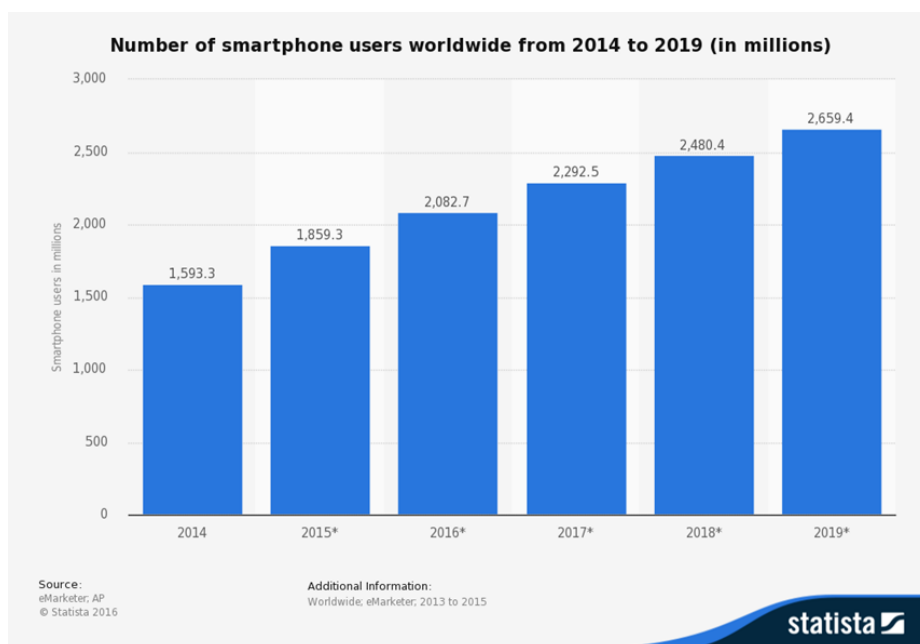

FIGURE 24. Number of smartphone users<sup>[36]</sup>

The worldwide smartphone sales were up to 1.4 billion in 2015. As the smartphone demand rises, the consumption of batteries will also grow. It shows that new batteries have a tremendous potential.

TABLE 1. Worldwide Smartphone Sales to End Users by Vendor in 2015 (Thousands of Units)<sup>[37]</sup>

| Company | 2015 Units  | 2015 Market Share (%) | 2014 Units  | 2014 Market Share (%) |
|---------|-------------|-----------------------|-------------|-----------------------|
| Samsung | 320,219.7   | 22.5                  | 307,596.9   | 24.7                  |
| Apple   | 225,850.6   | 15.9                  | 191,425.8   | 15.4                  |
| Huawei  | 104,094.7   | 7.3                   | 68,080.7    | 5.5                   |
| Lenovo* | 72,748.2    | 5.1                   | 81,415.8    | 6.5                   |
| Xiaomi  | 65,618.6    | 4.6                   | 56,529.3    | 4.5                   |
| Others  | 635,368.5   | 44.6                  | 539,691.3   | 43.4                  |
| Total   | 1,423,900.3 | 100.0                 | 1,244,739.8 | 100.0                 |

\*The figures for Lenovo include sales of mobile phones by both Lenovo and Motorola

## 7.2 Factors Affecting Market

The trend of the cell phone battery market development currently will not be cheap and low volume. It should be a high-stand product. As intelligent mobile phone functions increase, mobile phone has become large sized with a colourful touch screen and more functional from small dark screen and simple functions. The mobile phone should be in standby for long time in such frequency operational situation. Previous phones original battery capacity was generally in about 1000 mA even lower. Normal using may last 5-6 days. But now smartphones original battery capacity is 2000 mAh or more generally, in the case of normal use with less a day. So the higher capacity batteries would meet market demand.

The development trend of mobile phone battery market will follow the development of intelligent phone functions and is bound to become the high-end products as the leading trend.

The new models battery selling prices are high nowadays, because the big battery capacity costs more. For example, the Samsung I9500 mobile phone battery capacity is 2600 mA, the price of 59 Yuan.

The safety of the battery is also concerned by the users, especially when the mobile phone is an indispensable device for the daily life. No one want to take a dangerous goods every day. Safe mobile phone battery is easier access to markets.

## 7.3 Mobile phone battery manufacturers in China

Mobile phone battery industry in China started in about 1990. In recent years, with the rapid growth of Chinese mobile communications industry, especially explosive growth of the mobile phone market, mobile phone batteries get widespread concern in various industries. China's major mobile phone battery manufacturers are very concentrated. At present, there are more than 1,000 in total Chinese battery enterprises distributed mainly in Guangdong Province. In addition, although there are a small number of foreign battery enterprises in China, its gross profit is highest of all enterprises. With the maturation of Chinese lithium-ion battery technology, the global lithium-ion batteries began to shift to China. Foreign companies are adjusting their global strategy, China will be its global mobile phone battery key production base. The leading global mobile phone battery company Sanyo

Electric has its own production bases in Beijing and Tianjin. In addition, Panasonic and Sony established bases in Wuxi. Korea VK batteries came into Fujian.

Although there are many problems to be solved in Chinese mobile phone battery market, there are hidden opportunities that cannot be ignored. Because of the huge amount of Chinese mobile phone users, the consumption of the phone battery is also large. In the next few years' Chinese mobile phone battery market will continue to show an increasing trend. Fuel cells and other new batteries are widely regarded as the industry's future development trend of mobile phone battery.

## 8 CONCLUSION

From the first successful mobile phone battery developed to the world's first mobile phone, then to today's intelligent era. Smartphones have become essential tools for communication and Internet surfing. With a variety of applications and mobile games frequently used, the lasting time of mobile phone battery, has a direct impact on experiencing powerful smartphone's functions and normal communication. The battery should be developed and this will play an important role for users. These changes will bring people into the real information age. Today, lithium batteries have reached an unprecedented position, although there are still many drawbacks, such as short battery life and high prices.

In the process of doing the final thesis, we realized how people desired to have a technology revolution on mobile phone batteries. A huge potential market is waiting for us. But there are still many counterfeit or substandard mobile phone batteries on the markets under the slogan of large capacity or new technology. When changing the battery, we should be aware of that. Furthermore, those fakes have no safety for using.

There is no doubt that wireless charging will be one of the direction of a mobile device development in the future, that is also one of the hottest technologies for manufacturers to study. In fact, electronic products are so popular today, each of us has a number of different kinds of chargers and charging cables. It is not convenient for us. The wireless charging technology is trying to solve this problem. On the one hand, wireless charging technology allows users to get rid of cable trouble, on the other hand it can also solve the general problem of the charger. Quick charging and wireless charging have improved charging efficiency at a large extent.

In addition, quick charging is just to charge up to 50% or 60% in some minutes rather than 100%. This is a kind of way to protect the battery. It is necessary to control the charging speed when the battery is almost full time. Each person must develop good habits of charging, so that battery life will be longer.

In the end, the new mobile phone battery technology seems very promising but many are still in the laboratory stage, due to various reasons such as cost, practicality that the battery could not into



mass production. So the biggest concerning point is still the lithium batteries. We expect that there will be a breakthrough and revolution about the new mobile phone batteries in the future.

## 9 REFERENCES

- [1] Internet & Mobile Phone Users Worldwide 2015: 50% Population Is On Internet [REPORT]. By Rajeesh Nair, Posted on 27 May, 2015. Available from <http://dazeinfo.com/2015/05/27/internet-mobile-phone-users-worldwide-2000-2015-report/>
- [2] The Best Thing Ever. By rudyblues57, Posted on 16 February, 2016. Available from <https://rudyblues.wordpress.com/2016/02/16/the-best-thing-ever/>
- [3] Cell Phone Battery History. By ChargeTech, Posted on 31 March, 2012. Available from <https://charge.tech.com/cell-phone-battery-history/>
- [4] First mobile phones, Available from <http://phone70.blogspot.fi/2009/11/first-mobile-phones.html>
- [5] Nickel-Metal Hydride Batteries, By John Ewing, Posted on 29 September, 2014. Available from [https://prezi.com/ui\\_xcdkh\\_bqa/nickel-metal-hydride-batteries](https://prezi.com/ui_xcdkh_bqa/nickel-metal-hydride-batteries)
- [6] Mobile Phone Chargers - Other makes and models, Available from [http://uplinkitsolutions.com/index.php?main\\_page=product\\_info&products\\_id=56](http://uplinkitsolutions.com/index.php?main_page=product_info&products_id=56)
- [7] Universal Li-Ion Battery Charger with USB Output for Mobile Phones: Nokia, LG, Sony Ericsson, Samsung, Motorola, Blackberry. Available from <http://www.amazon.co.uk/Universal-Li-Ion-Battery-Charger-Output/dp/B005EW2U6Q>
- [8] Universal Mobile Charger. Available from <http://www.elect-spec.com/universal-mobile-charger/>
- [9] How to conform to China's new mobile phone interface standards, By Crystal LAM Yan Yan and Harry LIU Yao Hui, Posted on 22 July, 2007. Available from [http://www.eetimes.com/document.asp?doc\\_id=1275077](http://www.eetimes.com/document.asp?doc_id=1275077)
- [10] The man who brought us the lithium-ion battery at the age of 57 has an idea for a new one at 92, By Darren Carroll, Posted on February 05, 2015. Available from <http://qz.com/338767/the-man-who-brought-us-the-lithium-ion-battery-at-57-has-an-idea-for-a-new-one-at-92>
- [11] 10 common misconceptions about mobile device batteries, By Jack Wallen, Posted on 29 January, 2015. Available from <http://www.techrepublic.com/blog/10-things/10-common-misconceptions-about-mobile-device-batteries/>
- [12] The United States women's iPhone 4 charging explosion, CCTV, Posted on 23 March, 2012. Available from <http://news.163.com/12/0323/09/7T97QPLP00011229.html>
- [13] Lithium-ion battery, Wikipedia. Available from [https://en.wikipedia.org/wiki/Lithium-ion\\_battery](https://en.wikipedia.org/wiki/Lithium-ion_battery)
- [14] If it were up to you, what would you have manufacturers focus on in 2016? By Chris P, Posted on 28 Dec 2015. Available from [http://www.phonearena.com/news/If-it-were-up-to-you-what-would-you-have-manufacturers-focus-on-in-2016\\_id76976](http://www.phonearena.com/news/If-it-were-up-to-you-what-would-you-have-manufacturers-focus-on-in-2016_id76976)

- [15] Revealed: the first hydrogen-powered battery that will charge your Apple iPhone for a week, By Christopher Williams, Posted on 22 Aug 2015. Available from <http://www.telegraph.co.uk/finance/newsbysector/mediatechnologyandtelecoms/11818151/Revealed-the-first-hydrogen-powered-battery-that-will-charge-your-Apple-iPhone-for-a-week.html>
- [16] Stockholm techies use water to charge mobile phones, By Nancy Owano, Posted on 12 January, 2012. Available from <http://phys.org/news/2012-01-stockholm-techies-mobile.html>
- [17] MICRO FUEL CELLS, By Mikayla Smith and Robert F. Savinell, Posted on January, 2013. Available from <http://knowledge.electrochem.org/encycl/art-f05-fc-micro.htm>
- [18] Direct Methanol Fuel Cell Methanol and Water Crossover. Available from [https://www.wpclipart.com/science/how\\_things\\_work/Direct\\_Methanol\\_Fuel\\_Cell\\_\\_Methanol\\_and\\_Water\\_Crossover.png.html](https://www.wpclipart.com/science/how_things_work/Direct_Methanol_Fuel_Cell__Methanol_and_Water_Crossover.png.html)
- [19] What are new battery types at present? Posted on 30 October, 2009. Available from <http://www.elecfans.com/yuanqijian/dianchi/dianchishengchang/20091030100783.html>
- [20] New mobile phone battery charging only takes a minute, China Youth Daily, Posted on April 7, 2015. Available from [http://news.xinhuanet.com/tech/2015-04/07/c\\_127662640.htm](http://news.xinhuanet.com/tech/2015-04/07/c_127662640.htm)
- [21] Our school posted in "Nature" achieving a breakthrough, Posted on 07 April, 2015. Available from <http://news.hnu.edu.cn/zhyw/2015-04-07/6297.html>
- [22] More sensitive touch screen and longer battery life of the graphene mobile phones is coming, Available from <http://mobile.163.com/15/0303/10/AJPCIHDA00111790.html>
- [23] The flexible battery is here, soon your watch strap will be a power supply, Posted on 18 June, 2015. Available from <http://www.pocket-lint.com/news/134338-the-flexible-battery-is-here-soon-your-watch-strap-will-be-a-power-supply>
- [24] Commercially-available NanoTritium battery can power microelectronics for 20+ years, By Paul Ridden, Posted on August 15, 2012. Available from <http://www.gizmag.com/city-labs-nanotritium-betavoltaic-battery/23720/>
- [25] What is the principle of battery fast charge? By Ma Lili, Posted on 20 May, 2014. Available from <https://www.zhihu.com/question/23831848>
- [26] Quick Charge 3.0 vs. 2.0 vs. 1.0. By Angela, Posted on 16 March, 2016. Available from <http://www.easyacc.com/media-center/quick-charge-3-0-vs-2-0-vs-1-0/>
- [27] Quick Charge 3.0 vs. 2.0 vs. 1.0. By Angela, Posted on 16 March, 2016. Available from <http://www.easyacc.com/media-center/quick-charge-3-0-vs-2-0-vs-1-0/>
- [28] Is Mobile phone charging too slow? The quick charge technology can help you. By Wang Yang, Posted on 12 August, 2015. Available from <http://digi.tech.qq.com/a/20150812/008188.htm>
- [29] Qi vs. A4WP: War of the wireless charging standards. By ROB TRIGGS. Posted on 15 April, 2013. Available from <http://www.androidauthority.com/qi-a4wp-wireless-charging-standards-190836/>

- [30] Wireless Charging: Magnetic Induction or Magnetic Resonance? By Majeed Ahmad. Posted on 18 January, 2015. Available from <https://www.semiwiki.com/forum/content/4191-wireless-charging-magnetic-induction-magnetic-resonance.html>
- [31] Qi Wireless Charger Face-Off: Nokia DT-900 vs. Energizer (Video). By Joe Levi. Posted on 30 January, 2013. Available from <http://pocketnow.com/2013/01/30/nokia-dt-900-vs-energizer>
- [32] Lithium-Ion Battery (Medium-sized). Available from [http://biz.maxell.com/en/rechargeable\\_batteries/lithium\\_ion\\_m.html](http://biz.maxell.com/en/rechargeable_batteries/lithium_ion_m.html)
- [33] The mobile phone charger uses the circuit analysis of the supply convertor, Posted on 10 December, 2013. Available from <http://ele-tech.com/html/the-mobile-phone-charger-uses-the-circuit-analysis-of-the-supply-convertor.html>
- [34] Is Mobile phone charging too slow? The quick charge technology can help you. By Wang Yang, Posted on 12 August, 2015. Available from <http://digi.tech.qq.com/a/20150812/008188.htm>
- [35] Is an Octa-Core Better than a Quad-Core? Not Always! Android Processors Explained, By Mihir Patkar, Posted on 25 May, 2015. Available from <http://www.makeuseof.com/tag/is-an-octa-core-better-than-a-quad-core-not-always-android-processors-explained/>
- [36] Number of smartphone users worldwide from 2014 to 2019 (in millions). Available from <http://www.statista.com/statistics/330695/number-of-smartphone-users-worldwide/>
- [37] Gartner Says Worldwide Smartphone Sales Grew 9.7 Percent in Fourth Quarter of 2015, By Eg-ham, UK, Posted on February 18, 2016. Available from <http://www.gartner.com/newsroom/id/3215217>

