

Sandeep Adhikari

# Smart nest box

---

Helsinki Metropolia University of Applied Sciences

Bachelor of Engineering

Electronics

Thesis

3 February 2017

## **ACKNOWLEDGEMENT**

I want to thank Mr. Matti Fischer for giving me this opportunity to work on this project and helping me whenever I find myself in difficult situation. I would also like to thank Mr. Dibas Bhandari who was my partner for this project without whom our project would not be complete.

I would also like to thank Mr. Petri Valve for guidance on my writing and managing.

Helsinki 2 February 2017

Sandeep Adhikari

Author(s)	Sandeep Adhikari
Title	Smart Nestbox
Number of Pages	3 February 2017
Degree	Bachelor of Engineering
Degree Programme	Electronics
Specialisation option	
Instructor(s)	Matti Fischer, Principal Lecturer
<p>This is a bachelor degree thesis with an aim to design the intelligent nest box with sensors which will help to study about the living condition of the certain bird. At the same time this also helps to analyze the daily activities of the birds and also to be aware of presence of other creatures.</p> <p>In this project, different measurement were carried out from the help of sensors. Values of carbon-dioxide, humidity and temperature were measured inside the box whereas with the help of IR sensors the number of exit and entrance of the bird or other creature were counted. Different methods were used to verify the reading of sensors to be correct like Test Chamber, Multisim. A camera was used to monitor the activities of the bird.</p> <p>The data readings of sensors were read through LabVIEW. From this project, it was found that analog sensors when amplified correctly can give more precise data. The project was success to study the environmental status of the bird but further studies from this project can be continued.</p>	
Keywords	Data-acquisition, Sensors, Microcontroller, LabVIEW, Visitor Counter,

## Contents

1	Introduction	1
2	Background study	2
3	Smart Nest box	3
3.1	Temperature sensor	4
3.2	Humidity sensor	7
3.2.1	Communication Process DHT22	8
3.3	Visitor Counter	9
3.4	Air quality sensor	10
3.5	Web camera	11
4	Microcontroller	12
4.1	Arduino UNO	12
4.2	Measurement with microcontroller	13
4.2.1	Tmp36	14
4.2.2	Dht22 sensor	14
4.2.3	Infrared sensors:	16
4.2.4	Mq135 sensor	17
5	Measurement in test chamber	18
5.1	Tmp36 sensor	18
5.2	Dht22 sensor	19
5.3	Temperature test	19
6	Controller unit	21
6.1	LabVIEW	21
6.2	Arduino IDE	22
6.3	Webcam	22
7	Interface with LabVIEW	22
7.1	Block diagram for sensors	23
7.2	Block diagram for camera	24
7.3	Front panel view	24
8	Prototype installation	25

9	Result and discussion	25
10	Further development and possibilities	27
11	Conclusion	27
	References	29

## Abbreviations

MCU	Micro Controller Unit
UVC	USB (Universal Serial Bus) Video Class
VI	Virtual Instruments
IDE	Integrated Development Environment
PWM	Pulse Width Modulation
IR	InfraRed
LED	Light Emitting Diode
RH	Relative Humidity
USB	Universal Serial Bus
ICSP	In-Circuit Serial Programming
ADC	Analog to Digital Converter

## Appendices

- Appendix 1. Main Code
- Appendix 2. Block Diagram for Camera
- Appendix 3. Installation
- Appendix 4. Prototype with Result

## 1 Introduction

Nowadays world is very much dependent on the electronics and on its achievement. Not only the life of human but it has affected the life of other creatures too. Advancement in electronics has helped the world to be better place. In the field of research and study electronics plays the vital role. From the help of this advancement, along with human, various living creature's livelihood can be studied and make it better.

It is hard to imagine a life without electronics in this technology dominated world. With this world, so dynamic it is very difficult to cope up with changing environment, climate and resources. Human, as the most intellectual being may be able to accept and challenge the changing world but it is very hard for other creatures. In such situations, the latest development can be used with the help for this advance technology we can study the living condition of other being like animals and birds.

This thesis thus, focus on the study of living place of the birds. A smart nest that help to know the humidity level, carbon-dioxide concentration and temperature inside the nest of the bird. Another important function is to know whether other birds or creature enter inside the nest or not. And also, the camera which will help to capture the daily activities of the bird and helps in our study.

The aim of this thesis was to design a sample intelligent nest box. The idea was to measure the physical and environment conditions like temperature, humidity level, air quality. The final reading then can be seen on single screen through any means of platform like computer or laptops.



## 2 Background study

Nest box is a man-made home for any kind of species of bird to provide shelter for living. Due to increment in deforestation, many species had lost their natural habitat and were in risk of being endangered. Thus, to protect and provide house for them, British conservationist invented artificial box in 18<sup>th</sup> century. There can be different kinds of nest boxes varying in design, shape and size and can be made from different materials like wood, metals. Nest boxes can be as simple and natural as the bird needs or can be advanced with technology for study and research purposes.

After approving the topic from teachers, a brief background study was done to get the basic idea on how the nest box and its components should be. While studying for background it was found that, different programs were completed in this bird's nest. Different projects had different views and perspectives. For example, many mini projects were carried out in many schools of Belgium using camera and raspberry pi to monitor and study the bird species. Another similar kind of project was implemented in collaboration between Czech technical university and Czech university of life science to get biological data of any bird.

While collecting ideas for a good Nestbox, one research was found which had the similar theme as our thesis which was carried out in Spain having title "monitoring falcons with intelligent nest" by Zoe Romano. This research had similar concept like using microcontroller, sensors, IR sensors for real-time monitoring of falcons [1]. After some research on similar project, the basic plan was made to carry the work forward. A simple flow chart was made to continue the work smoothly.

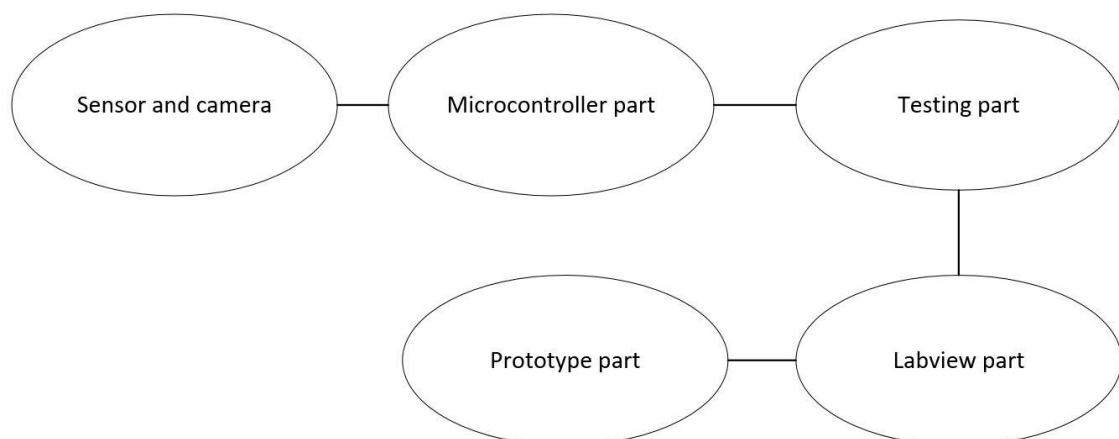

Figure 1. Working plan for thesis

As it was planned, first part was selecting sensors from many options. The sensors were chosen by their accuracy, input-output type, operating conditions, cost, size and other properties which were needed. After the selection of the sensors and their background study, microcontroller was chosen. Sensor which were needed to amplify through amplifier were amplified.

Along with sensors a simple webcam was picked up which could save image with high resolution and could save video if needed. To make it easier a simple HP webcam was used. Arduino Uno was chosen as platform to make the program to run the sensors. Microcontroller selection was to read the data result given from sensors to readable form. Arduino UNO was best for us in this part.

After the microcontroller part, testing part was included to show the working of the sensors were accurate. In LabVIEW part, the function was to communicate with sensors through Arduino and create a required block diagram to present all data result into simpler form. Last part in the plan was to install all the work done into sample Nestbox and to test the prototype in real environment.

### **3 Smart Nest box**

This is also simple living home for any bird like other nest boxes. But it features some scientific materials like sensors, camera, microcontroller and battery or external power. When all these components are connected to computer/laptop/phones the bird's everyday life can be checked and can provide assist if needed. The whole thesis was based on developing and testing this smart bird's home box. The nest box must be cost friendly, easy to install and outcome result should be easy to read for general people. The Figure 2 is just a rough sample design for our thesis.

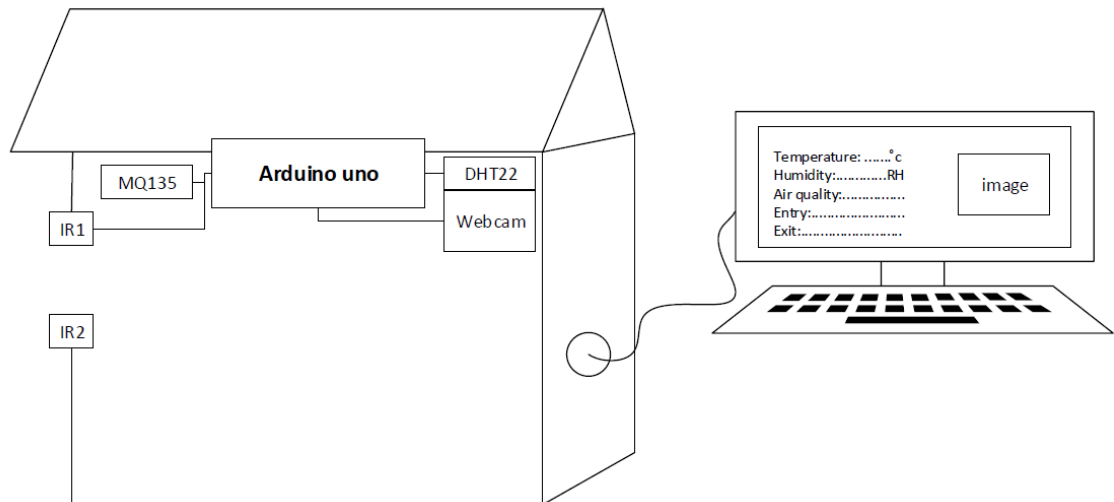

Figure 2. Simple design of nest box

As can be seen from the figure above, the thesis consists of nest box part and computer part or observable part to see the result. Nest box mainly has hardware components like sensors, webcam, Arduino, wires and box whereas the computer part consists mainly software part to support components of the nest box and communicating software LabVIEW from where the results can be seen.

While choosing the sensors part inside the nest box, many different sensors were taken into consideration. A good background study was done and the sensors were chosen according to the character and requirement for our thesis. A simple explanation of components can be found below:

### 3.1 Temperature sensor

One temperature sensor was needed to measure the temperature outside the nest box. The sensor should have the characteristic to work even in worse environment. TMP36 sensor is low voltage, precision centigrade temperature sensor. It could provide a voltage output which is linearly proportional to the Celsius temperature. It is stable with large capacitive loads which can be specified from  $-40^{\circ}\text{C}$  to  $+125^{\circ}\text{C}$ , provides a 750 mV output at  $25^{\circ}\text{C}$  and could operate to  $125^{\circ}\text{C}$  from 2.7 V supply, and had an output scale factor of  $10\text{ mV}/^{\circ}\text{C}$  [2.].

This sensor uses solid-state technique to determine the temperature that means if the temperature increases, the voltage across the diode increases. TMP36 is precise, doesn't need calibration which can work under many environmental conditions and is easy to use. TMP36 has many applications such as thermal protection, fire alarms, power system monitor and many others [2]. However, this sensor in our thesis was used to measure the temperature outside the nest box. TMP36 can be seen in Figure 3.

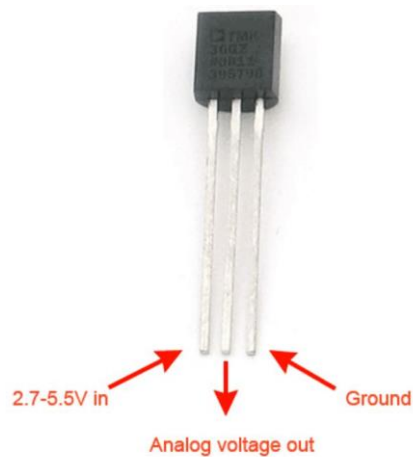

Figure 3. TMP36 temperature sensor [2]

It was known, TMP36 is an analog sensor, so a lot of different options were available to read the sensor value, for example using directly with microcontroller or with connecting first operational amplifier and then with microcontroller for precise readings. Since, the final prototype size needed to be small enough for bird it was decided not to use operational amplifier to make the work easier and simpler.

To show electronics part of the sensor, the operation with operating amplifier is also included. From datasheet of TMP36 the slope of this sensor could be calculated. The equation was then used to measure required values. Figure 4 shows the relation of this temperature sensor with output voltage vs temperature.

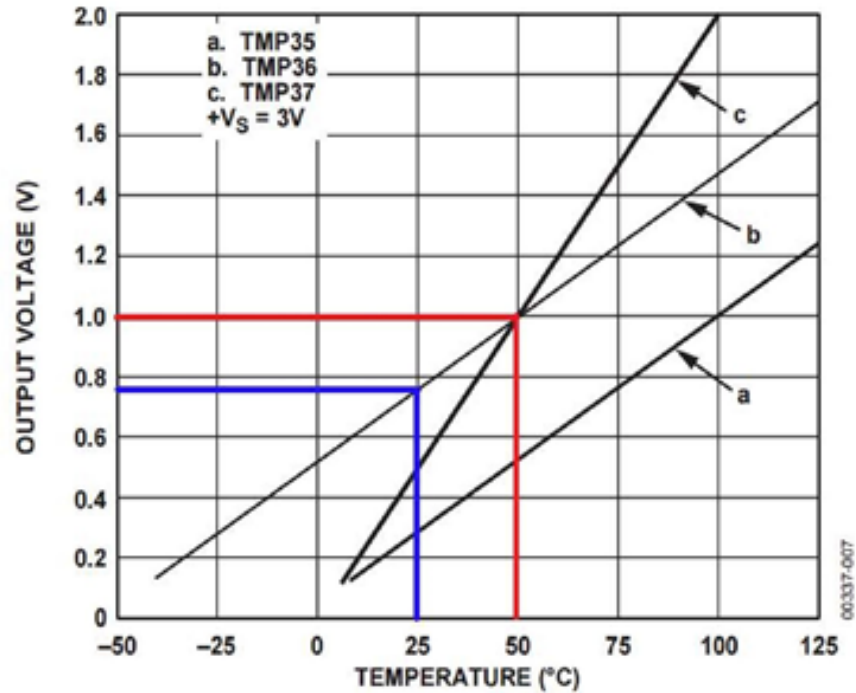

Figure 4. TMP36 output voltage vs temperature

Above figure taken from data sheet of tmp36 shows the linear relation of temperature with output voltage so, we get;

$$(x_1, y_1) = (750mV, 25^{\circ}C); (x_2, y_2) = (100mV, 50^{\circ}C) \quad (1)$$

From calculation of slope of straight line, we get

$$y = (x - 0.5) \times 100 \quad (2)$$

Using this above equation to calculate the minimum and maximum output voltage required to send towards the microcontroller. It was measured that at lowest temperature  $-40^{\circ}C$  the output voltage of sensor is equivalent to 0.1 V whereas at highest temperature of sensor capacity the tmp36 can give 1.75 V as an output voltage (Specification of TMP36 is from  $-40^{\circ}C$  to  $125^{\circ}C$ ) [2.]. The function of operational amplifier was known to us that it can be used to amplify the output was required.

Now by using operational amplifier and some resistors required circuit was designed which could amplify all values from (0.1-1.75) volts to (0-5) volts so that we could control

the input value and get the precise result from microcontroller. The circuit can be seen below with calculated resistors values.

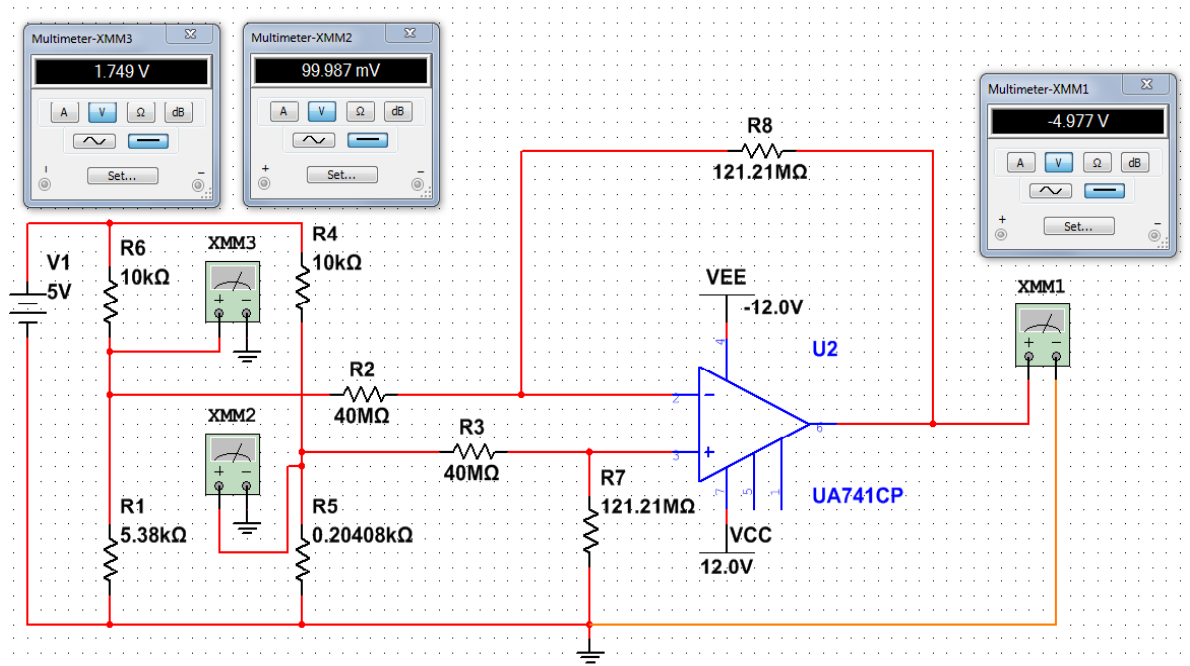

Figure 5. amplification circuit for the TMP36 sensor

In above figure, R1 resistor was considered as a variable resistor. The R1 variable resistor was then maintained in such ratio with other resistors to maintain the output voltage from minimum to maximum. The R1 resistor then could be replaced by TMP36. This figure shows the amplification at highest level.

### 3.2 Humidity sensor

Inside the nest box, both temperature level and humidity percentage were to be measured. First, two different sensors were thought to be used to measure these two different environmental conditions but while researching DHT22 was known to us which can measure both values from single sensor. This sensor is simple and basic for data logging. It is composed of two part a capacitive humidity sensor and thermistor.

This sensor converts data from analog to digital to give digital signal which is easy to read through any microcontroller. It is good to use in temperature condition from  $-40$  to  $125^{\circ}\text{C}$  temperature readings and 0-100% humidity readings [3.]. This sensor features a temperature and humidity sensor complex with a calibrated digital signal output. By using the

exclusive digital-signal-acquisition technique and temperature and humidity sensing technology, it ensures high reliability and excellent long-term stability [3].

Along with these it has others features like fast response, precise calibration, anti-interference ability, excellent quality. [3]. This sensor was used to measure the temperature and humidity level inside the nest box. The figure is dht22 sensor pin modes.

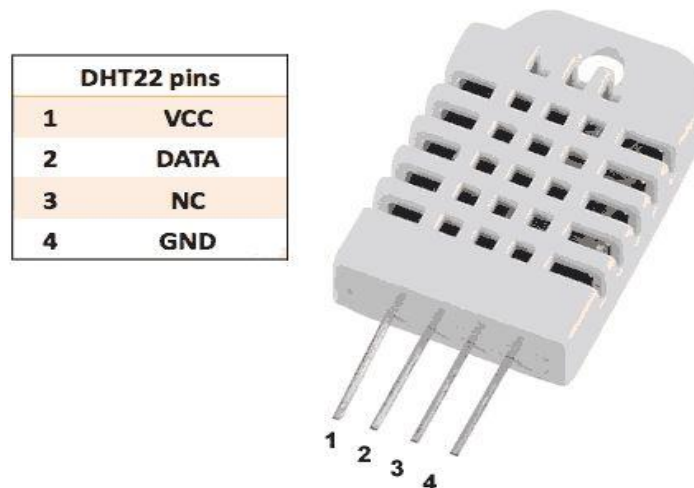

Figure 6.simple DHT22 sensor [3]

### 3.2.1 Communication Process DHT22

DHT22 uses single- bus data format to communicate and synchronize with MCU (micro-controller unit). This data consists decimal and integral parts and single process will take about 4ms.Data transmission format will be as follows:

- 8bit integral RH data + 8bit decimal RH data + 8bit integral T data + 8bit decimal T data + 8bit check sum.

Data transmission is said to be correct, when the check sum is equal to the last 8bit of the result of “8bit integral RH data + 8bit decimal RH data + 8bit integral T data + 8bit decimal T data” [4]. When the communication starts MCU pull down the data pin for at least 18ms and then will pull up data pin for 20-40 $\mu$ s until the dht11 response [4].when DHT22 detects the signal, it will pull down data pin for about 80 $\mu$ s followed by the data pin pull up for another 80  $\mu$ s.

While transition of the data, single data bit begins low-voltage-level for  $50\mu\text{s}$  and high-voltage level signal, the length of which decides whether the bit is 0 or 1. Data bit 0 has  $26\text{-}28\mu\text{s}$  high voltage length while data bit 1 has  $70\mu\text{s}$  high voltage length [4].

Figure 7 describe the complete data transmission

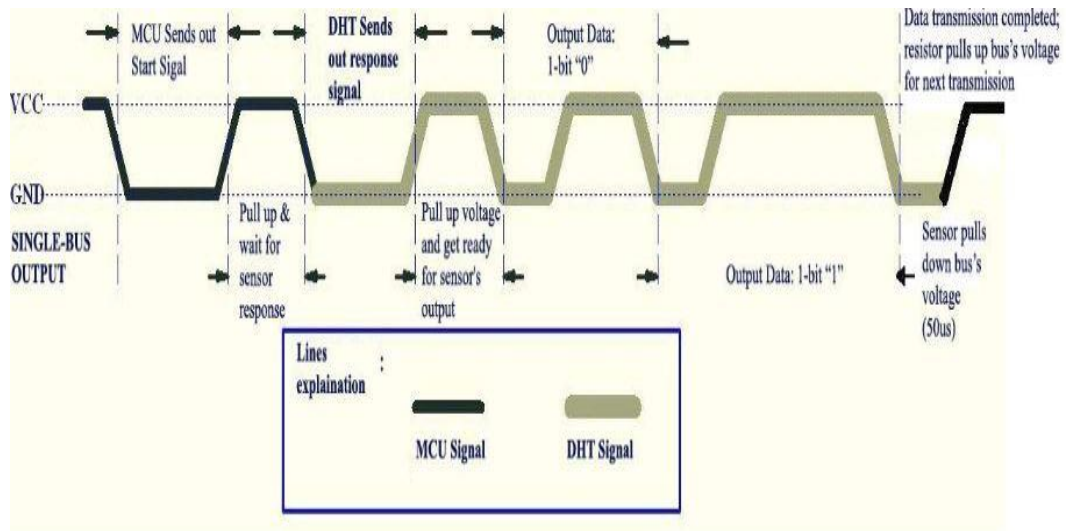

Figure 7. complete data transmission of DHT22 sensors [4]

### 3.3 Visitor Counter

To ensure the safety of the bird, the counting of entries or exits of bird or any other object needed to be done inside or outside the nest box. For that Infrared Sensors were used to count the number of entry and exit. IR sensor basically consist an IR LED (Light Emitting Diode) and a Photodiode, this pair is generally called IR pair or Photo coupler. IR sensor work on the principal in which IR LED emits IR radiation and Photodiode sense that IR radiation. Photodiode resistance change according to the amount of IR radiation falling on it. Hence, the voltage drop across it also changes and by using the voltage comparator we can sense the voltage change and generate the output accordingly [5].

#### Operating principle

In our thesis, sensors are used in indirect positioning; IR LED and photodiodes are placed parallel to each other. The obstacle help the falling of the IR radiation to photodi-



odes. As the transmitter emits radiation, the objects reflect some radiation to the IR receiver thus the output the sensor is defined [5]. Figure 8 demonstrate the circuit to sense the obstacle from IR sensors.

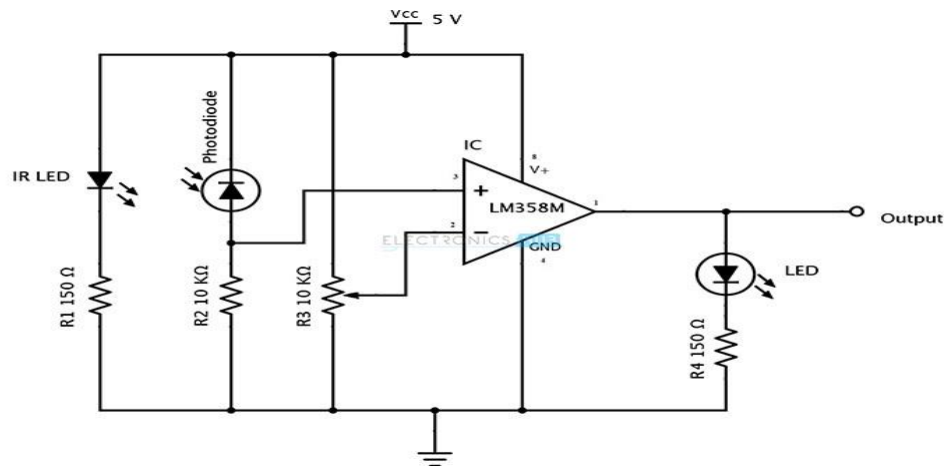

Figure 8. IR Sensor circuit [5]

The figure above consists of IR LED which emits infrared light, a photodiode that detects the light, a potentiometer which is used to calibrate the output of the sensor, an IC operational amplifier is used as voltage comparator and an LED [5].

### 3.4 Air quality sensor

One of the main necessity for any living being is air and the air should be of good quality for healthy life. The quality of air need to be measured so MQ135 was simple, easy to measure. MQ135 is an analog sensor that detects the air quality. It can detect gases like ammonia, benzene steam, sulphide, CO<sub>2</sub> and many others. It has SnO<sub>2</sub> as the sensitive material which help to convert chemical concentration in air to appropriate voltage range for the microcontroller. Sensor also contains electrode and heater made from plastic and stainless steel [7.].

Figure 9 is a figure of MQ135 sensor.



Figure 9.mq135 gas sensor [6]

This sensor needs 5V for operating and the power should be given externally since the heating needs 200mA current. The sensor needs to be heated for about 24 hours for the operating condition. The sensor consists 6 pins 4 of them are used as output signals and 2 pins are for heating current.

### 3.5 Web camera

For the better study and monitor every minutes of the bird's activity we decided to install a web camera inside the nest. Logitech HD webcam c525 was simple webcam used in home which also meet our required condition. This camera is capable of recording video quality 720 pixels and resolution of 8 megapixels for photo, along with other features like automatic light correction, autofocus, fluid crystal technology, 360° rotation design all of which are very useful to our project [9.]. Below is a simple picture of our webcam.



Figure 10.Logitech HD webcam C525 [7]

## 4 Microcontroller

A microcontroller is a compact microcomputer designed to govern the operation of embedded systems in motor vehicles, robots, office machines, complex medical devices, mobile radio transceivers, vending machines, home appliances and other various devices. A typical microcontroller includes a processor, memory and peripherals [10].

Nowadays there are many different microcontrollers available from different companies. We can choose the type according to our need and availability. Arduino Uno was used for our thesis. The description the microcontroller and use in the thesis can be observed below:

### 4.1 Arduino UNO

Arduino Uno is a microprocessor develop by the Arduino company that includes all the features of the microcontroller. It is based on the Atmega328. Arduino has operating voltage of 5V which can be from either computer or power. Generally, voltage from 7-12V is recommended, above voltage can cause overheating. It has 14 digital input/output pins and 6 analog input pins. It also includes power pins and USB connection, a power jack, 16 MHz quartz crystal, an ICSP header and reset button [11.]. *Figure 11* includes parts and their description of the Arduino UNO.

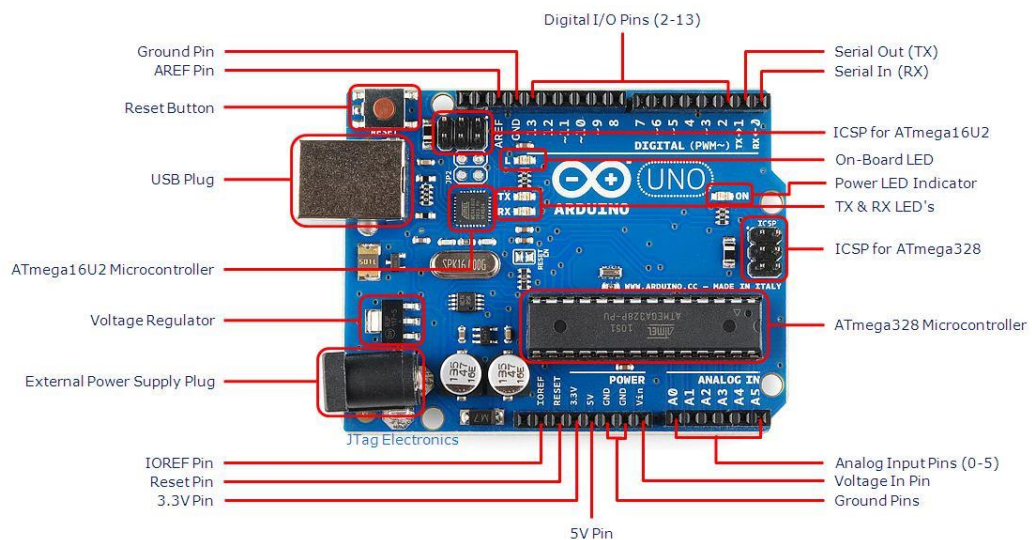

Figure 11 Arduino UNO board [8]

As shown in the figure 11, power pins that can be connected from external power sources. 5V pin is for board regulation, 3.3V pin is for 3.3 volt generated by on-board regulator. The board also has ground pins for the circuit. Similarly, IOREF pin provides the voltage reference with which the microcontroller operates [11.].

## INPUT AND OUTPUT PINS

There are 14 digital pins can be used as an input or output which operates in 5 volts. Each pin has 20-50k pull-up resistors and provide or receive 40 mA

- Serial out(TX) and serial In(RX) are used to transmit and receive serial data
- Pins next to the sign (~) can be normal digital pins and it can also act as pulse-width modulation(PWM)
- SPI (serial peripheral interference) pins support SPI communication using SPI library
- Analog input pins A0 -A5 which converts analog input values and convert to readable digital value
- Atmega328 are the integrated circuit which as a brain or Arduino
- Atmega16U2 take care the USB connecting part of Arduino Uno
- ICSP header are to upgrade or load firmware into microcontroller [11.].

## 4.2 Measurement with microcontroller

Sensors reading were done through Arduino Uno and Arduino IDE software was used to create the suitable program to translate the sensors result into simpler form which can be read with unit. The description of every sensors with codes are done below:

#### 4.2.1 TMP36

Since, the decision was made to connect sensor directly with Arduino. 3 pins of sensor were connected to A0 as output, ground and 5V from the Arduino. The Arduino codes to read the analog data are as follows:

```

Int sensorPin = 0;
Void setup() {
Serial.begin(9600);
}
Void lopp() {
Int reading = analogRead(sensoroutput);
Float voltage = reading * 5.0;
Voltage/ = 1024.0;
Serial.print(voltage);
Serialprintln("volts");
Float temperatureC = (voltage - 0.5) * 100; Serial.println(tem-
perature);
Serial.print("degrees C");
Float temperatureF = (temperature * 9.0 / 5.0) + 32.0; Se-
rial.print(temperatureF);
serial.println("degrees F");
delay(1000);
}

```

From the code above it can be known, the temperature values in Celsius and Fahrenheit are through function `Serial.print()`. `Float()` helps to converts the data while `loop()` helps to run the programmed repeatedly. `setup()` help to run the Arduino and connect to the computer for the result display. `delay()` function delays the result to be displayed. After verification, the temperature reading from serial monitor can be studied.

#### 4.2.2 DHT22 sensor

This sensor is digital sensor so direct connection with microcontroller was done to get result. DHT22 sensor has four pins, first pin is for the voltage so we connected it to Arduino either 3.3 or 5V. Second pin is for the output so it goes to port 2 and the forth

one is used to connect the ground. Extra 10k resistor was needed between VCC and output for pulling up data line.

At first, a library was downloaded to initialize the sensor. Then adfruit library was installed to make the process easier for sensor. Now on the class dht11 can be used without a change. Using read22() function the values of temperature and humidity can be read. The values then can be put into the variables t and h. The Arduino codes for DHT22 sensor can be seen below:

```
#include <DHT.h>
#include <DHT_U.h>
#define DHTPIN 2
#define DHTTYPE DHT22
DHT dht(DHTPIN, DHTTYPE);
Then sensor is initialized.
Void setup()
{
Serial.begin(9600);
Dht.begin();
{
    delay(2000);
    float h = dht.readHumidity();
    float t = dht.readTemperature();
Serial.print("Humidity");
Serial.print(h);
Serial.print("\t");
Serial.print("Temperature");
Serial.print(t);
Serial.print("\t");
Serial.print("Farenheit");
Serial.print(tf);
Serial.print("\n");
delay(2000);
}
```

Final results are the temperature and humidity values. Two libraries `<DHT.h>()` and `<DHT_U.h>()` were needed to convert reading to humidity and temperature values. As this code are verified, the temperature and humidity values in degree, Fahrenheit and humidity percent is printed in serial monitor window in delay of every 2 seconds.

#### 4.2.3 Infrared sensors:

Two IR sensors were used to count the entry and exit of obstacle placing them parallel so the output of the counter was connected to 7 and 8 pins of Arduino for digital reading. Remaining two ports of the two IR sensors to the ground the ground and VCC 5 V. The Arduino codes to count the entry and exit of the obstacle in the nest bird are;

```

Int total = 0;
Int total1 = 0;
Void setup()
{
pinMode(8, INPUT);
pinMode(7, INPUT);
Serial.begin(9600);
}
Void show()
Serial.println(total);
Serial.println("Entry.");
Serial.print(total1);
Serial.println("EXIT");
}
Void loop()
If (digitalRead(7) == LOW){
While (digitalRead(8) == HIGH){
}
Total++;
Show();
Delay(1000);
}
else if(digitalRead(8) == LOW){
while (digitalRead(7) == HIGH){

```

```

}
total1++;
delay(1000);
}
}

```

Two values were recorded through total and total1 function. As in listings above the setup() function was used to start the Arduino. Pin mode 7 and 8 were used for the communication to print the result entry and exit. After the counting function show(), values were read from either 7 or 8 pins noticing the value is HIGH OR LOW. Verification of the above codes were done to count the number entries and exits; the data result could be seen in 1000 seconds' time gap.

#### 4.2.4 MQ135 sensor

The MQ135 can be used as analog sensor to get the air quality measurement. The output of the sensor was connected to A1 pin of Arduino Uno to get the result. Figure 12 shows the circuit we used for our test.

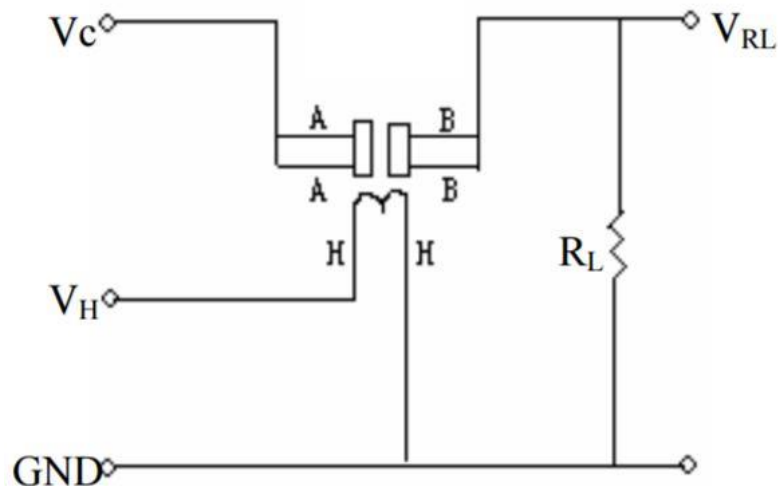

Figure 12.test loop for mq135 [9]

As can be seen in figure we connected A pins to power source. B pins to the output pins and Ground. From two H pins, one pin was used to get the required heat for sensor and another to ground through load resistor( $R_L$ ). 22k potentiometer was required to connect for the accuracy of the readings. The Arduino code can be seen below:



```
int analogVoltage;
void setup()
{
  Serial.begin(9600);
}
void loop()
{
  analogVoltage = analogRead(1);
  Serial.println(analogVoltage, DEC);
  delay(100);
}
```

Listing 1.Arduino code for mq135 sensor

Above Listing 1 defines the integer of analog voltage. The analog voltage value was printed from `Serial.println()`. `loop()` was used to run the program as used in above listings and to get the better result some seconds were delayed in every loop.

## 5 Measurement in test chamber

The readings taken from microcontroller was a result from single experiment so the accuracy of the data was questionable. Therefore, to show that our test give accurate result, test chamber testing was done. The idea was to compare the value from the microcontroller with situation given from test chamber. The study of the sensors is described below:

### 5.1 TMP36 sensor

After keeping the temperature sensor inside the test chamber, different conditions were given inside the chamber like changing the temperature values. When the temperature was constant inside the chamber then Arduino result was monitored. The data were then compared in graph and we got the following result.

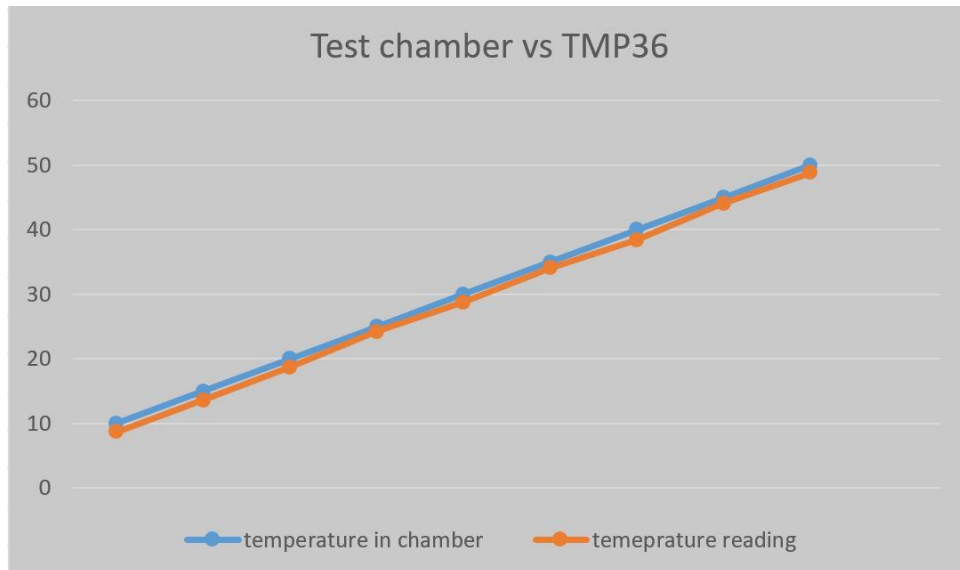

Figure 13. Test chamber vs reading graph

After the comparison, the result from both microcontroller and test chamber, the data were almost equivalent to each other at every environmental condition so the decision was taken to use TMP36 for the thesis.

## 5.2 DHT22 sensor

Two different tests were done for DHT22 sensor at the same time, first to compare temperature values with Arduino values and for humidity level comparison with microcontroller values. To test inside the test chamber, temperature and humidity were maintained inside the chamber, when the test chamber reached up to the given condition then the Arduino values. The sensor was still connected to the Arduino Uno while testing in test chamber. Following results were found after the tests:

## 5.3 Temperature test

After maintaining various values, the data given from both components (Arduino and test chamber) were compared in graph that can be seen below

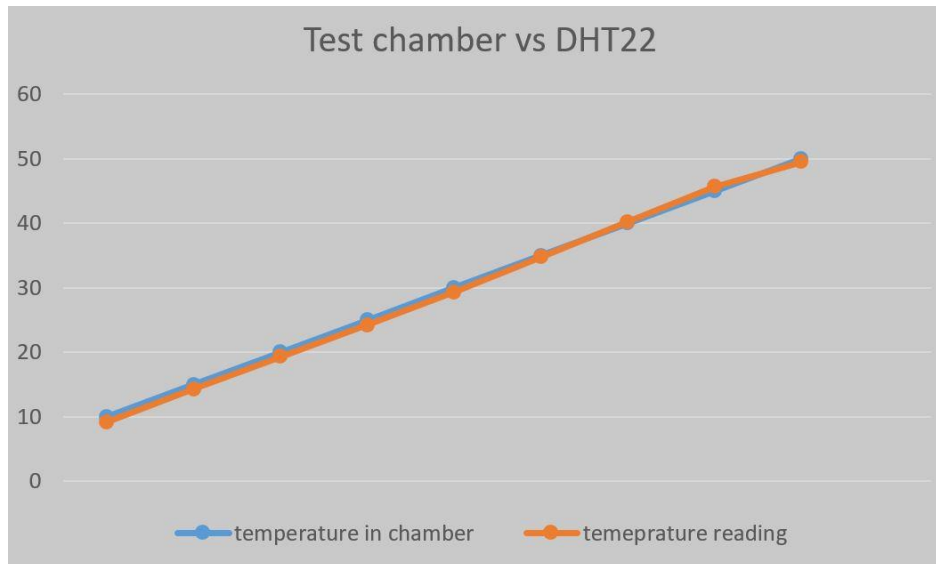

Figure 14. Test chamber vs reading graph dht11

Above table as graph shows that the results in test chamber and our sensor reading were almost similar which made our test success.

### 5.2.2 Humidity test

same process was repeated as temperature to test the precision of microcontroller reading with test chamber. The results can be seen

Figure 15.

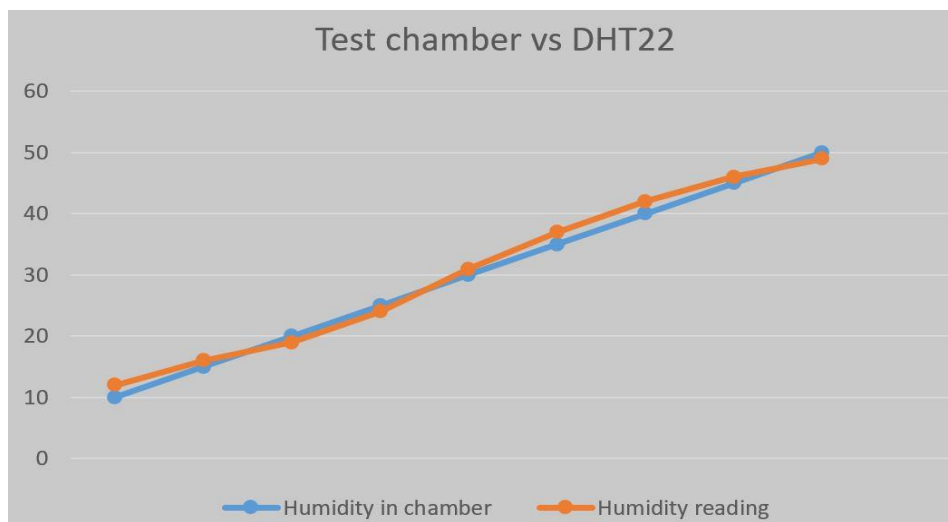

Figure 15. Humidity precision test graph dht11

Thus, from this test it was considered that the working was heading for right direction. The Arduino codes and sensor can be used for practical purpose.

## 6 Controller unit

As it can be noticed in Figure 2 the other part from nest box is controller unit which consists the computer part. All the required software was installed in controller part. The result can be seen in this part. The work done in the thesis was to be used in daily life so the final product should not be complex to read. To make it simple, a controller unit was necessary where all the output could be examined. After all the testing, the result was to be shown in a simpler form. LabVIEW was chosen as the controller software from where we could easily observe all the result in one front panel.

### 6.1 LabVIEW

National instruments developed a platform for visual programming language which has its language “G”. With a graphical programming syntax that makes it simple to visualize, create and code engineering systems. LabVIEW is very helpful in time saving for testing. LabVIEW also enable us to operate with other software either form alternative development or open-source platform [12.].

LabVIEW is highly productive environment for creating custom application which help to interact with real world such as in fields of science and technology. The programming that we use in LabVIEW helps us to tie together data acquisition, analysis, and logical operation. The graphical approach is simpler that focuses more on data and operation that are being performed on the data. LabVIEW can support many hardware devices like cameras, sensors, data acquisition devices, familiar programming model for all hardware devices and many more. The integration with hardware is also much easier form consistent programming approach. LabVIEW is flexible to many hardware to deploy our code [13.].

The LabVIEW enable us to handle hundreds of specialized functions and algorithm which are not included with general programming languages. Different libraries for signal processing, communication, connectivity with many others are available. Different interactive tools such as graph and tables enable us to view our data [13.]. Visa serial port and

Visa acquisition software allowed us to communicate our external hardware sensors, camera and microcontroller with LabVIEW to see the result of our project in LabVIEW window.

## 6.2 Arduino IDE

The Arduino Integrated Development Environment is web editor that makes easy to write code and upload it to the board. Sketches are software for writing programs and are written in text editor which can be saved in file extension .ino. Since it is online web editor it is always up-to-date. The editor allows us to write code, edit, copy/paste, add or use libraries, and also shows us the errors. It allows us to save the file according to our desired location. Another advantage of Arduino IDE is that the file is also saved in cloud which prevent from being deleted [14.]. With different commands, available make it more reliable to use the software.

Arduino IDE allows us to manage more than one files like .c extension, C++ files or header files. There is good updated communication system between software and computer with different port available. The connection can be checked form computer and Arduino board [14.]. If codes and files update correctly, final result can be studied in serial monitor.

## 6.3 Webcam

The webcam was connected to the computer with the help of UVC {USB (Universal Serial Bus) Video Class} drivers installed in computer and Visa acquisition software was used to interface with LabVIEW that helps to display and save images and allowed us to monitor the bird and other activities inside the nest box.

## 7 Interface with LabVIEW

First, all the sensors were interfaced with microcontroller then the results were compared with results in test chamber. A platform was required to communicate all the results from microcontroller and display the results in single screen. For that LabVIEW was chosen which was easy and meet all our required needs. Camera was also able to interface with LabVIEW to monitor the bird.

## 7.1 Block diagram for sensors

First, through VI package manager Arduino was interfaced with LabVIEW. A new blank VI was created, with the help of tools and components available a suitable program was created. Visa serial port was used to communicate Arduino to LabVIEW through any means of computer device. Visa serial was then used to read all the data from Arduino. Then while loop was created to run the program until the desired time. Figure 16 is complete program created for all sensors in LabVIEW.

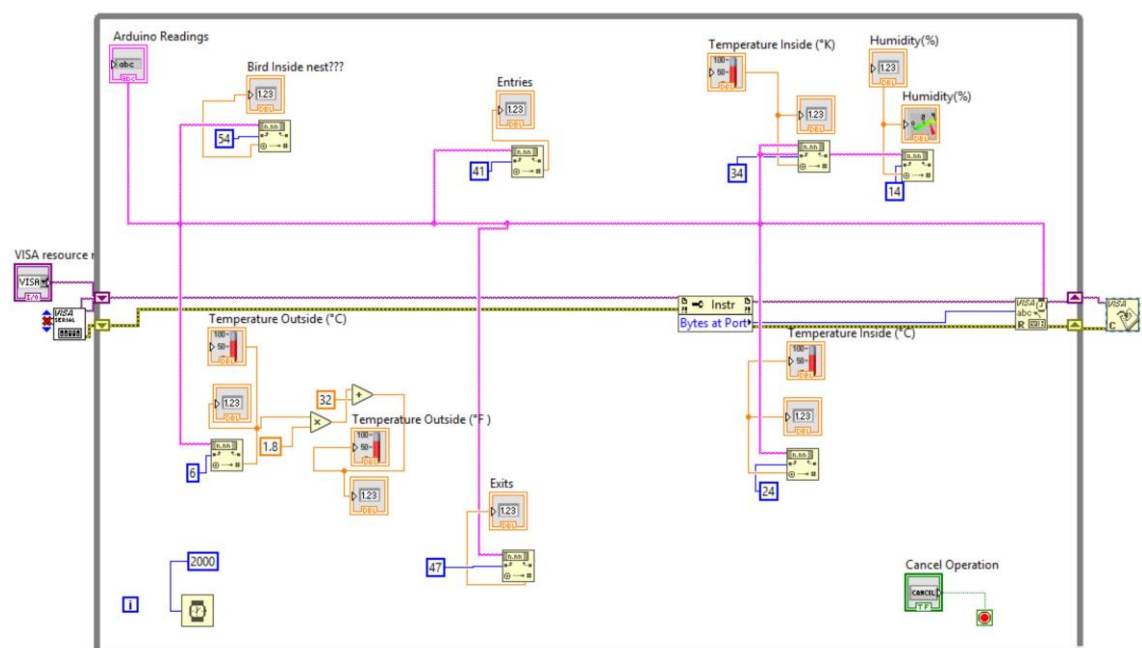

Figure 16. complete block diagram for all sensors

All the sensors result was displayed as shown in the above figure. All the results of Arduino are dragged in Arduino readings where the reading of all sensors can be seen together in single line. Then for every different data result, specific constants were given to read the character from the Arduino readings which then can be displayed in their given area. For example, to extract the data result of only outside temperature, a sub-program was created with the help of constant, control and indicator.

The conversion function was used to read the certain number of data. Here in this example, the number 6 indicates that the character from 0 up to 6 are dragged for this function. The character is then displayed in front panel where the outside temperature is

located. Same process was done for humidity sensor and IR sensors. A timer was given for the function to show the data and through the loop can be ended. Visa read function was then used to read the bytes from visa resource name. A close function was needed to close the function which also contains error information.

## 7.2 Block diagram for camera

Separate block diagram was created for the webcam to save image and store which could be shown along with other sensors. First a port was specified then camera was opened. The IMAQ then would help to create image which is captured by the IMAQ grab. Image location is then given to store and unique name is given to the filename. The image is then saved to file path specified, with appended name. If any errors occurred in the loop then it can be stopped and the errors can be handled. Appendix (2) shows the block diagram needed for camera.

## 7.3 Front panel view

Figure 17 is the front panel of the LabVIEW to show the final data of the thesis.



Figure 17. Front panel view for all the data results

"VISA resource name" indicates in which port microcontroller is connected. After that, all the values can be observed in "Arduino reading". Camera port also can be seen in top part of the front panel. Below them are bar meters and indicators to view the humidity

and temperature value analogically and also small window that display the digital value for the same.

The right most side has a small window for camera from where image and videos can be monitored, the locations where all the image are saved with their numbers. The left bottom part of front panel has display for the counter of number entry and exit of the bird. Also, the existence of bird in nest can be seen. The quality of air is displayed in with led light where the air is clean or polluted with warning sign is the air is polluted.

## **8 Prototype installation**

The complete work done was to be observed in the prototype for the final success. To install hardware a metal box from our school laboratory was used. The box was used to replicate as the nest box. Since we had a rough idea where all the components should be placed in actual nest box. DHT22 sensor, camera, MQ135, two infrared counter sensors to count the number of exit and existence of bird were kept inside the Nest box.

TMP36, microcontroller, and one infrared counter sensor to count entry were kept outside the box. The positioning of the components can be seen appendices (3) and (4). The components and wiring were tried to place in box in such a way they do not interfere with bird. Then from microcontroller it was connected to computer/laptop for LabVIEW results.

## **9 Result and discussion**

After the selection of right sensors for our project, further studies were done about the sensors. All the hardware was dealt individually and proceed toward microcontroller part. Sensors and camera were tested individually with Arduino. Single Arduino program was created for all the sensors to get the result in single window. The final code for the thesis can be seen in appendix (1). The results were then compared with test chamber results Since our goal of the thesis was to measure environmental conditions through our sensors like temperature conditions, humidity, air quality and counting of bird.



In the prototype Nestbox created in laboratory, a demonstration was done with hair dryer, ice packed bag and small balls (referred as birds). All sensors worked as expected, temperature sensors rose when dealt with hair dryer and fell with ice packed bag. Humidity sensor when interacted with dryer showed decreased in humidity percent. Air quality sensor also reacted when encountering with the help of burning matchstick by increasing the analog values. Camera was also able to take pictures of activities inside the prototype. The Infrared sensors counted the number of entries and exits of a small ball which was referred as bird. All the results could be seen in LabVIEW, front panel which showed that our final work met the primary goal which was set at the starting of thesis. A sample result can be seen in below figure.

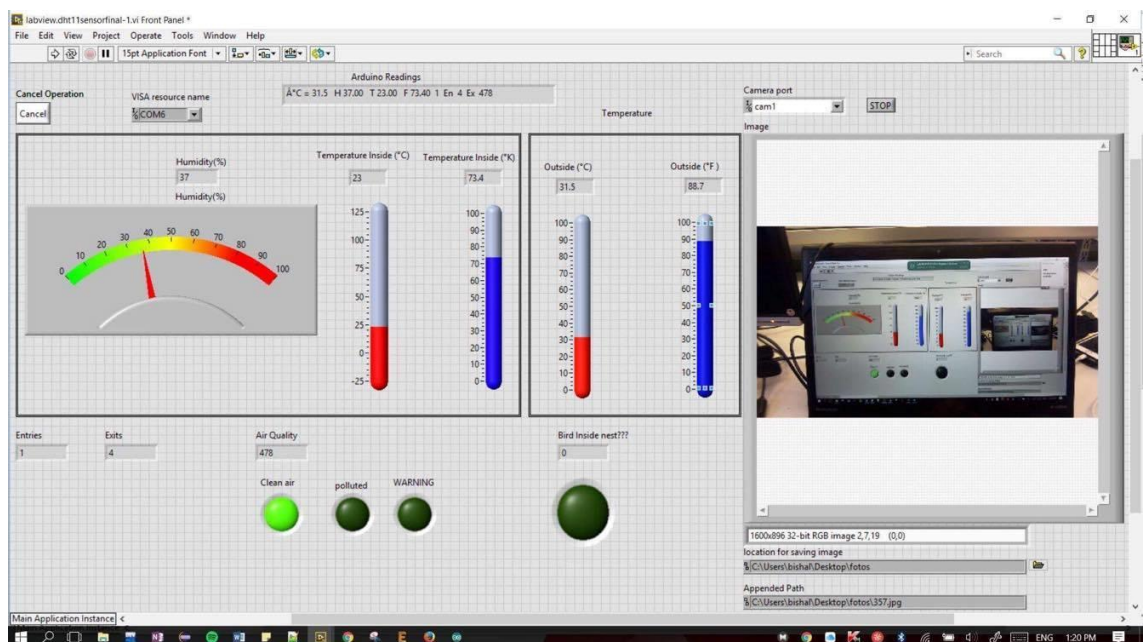

Figure 18. sample result of the thesis

The result above was from Metropolia school laboratory. Temperature sensor TMP36 was kept inside test chamber with the temperature maintained about 33 degree Celsius. DHT22 sensor, MQ135 sensor, counter sensors and camera was kept outside test chamber in a room with room temperature. As can be seen in the result above, the DHT22 sensor showed temperature value of 23 degree Celsius and 37 percent humidity level. Refereeing small balls as birds, they were used to count the number of entries and exits. Three balls were taken outside and one ball was kept inside and the number result were shown correctly.

The images or videos recorded from the webcam are redirected to the LabVIEW. The images then can be monitored in the right most part of the front panel. The images are saved in the given location. The status of the air was clean while testing. All the sensors were connected from COM6 and for camera the communication was done through CAM1.

## **10 Further development and possibilities**

Since this whole project is research and development work. A lot of advancement can be added to make this more scientific. Even the hardware and software used for this project can be upgraded through research and finding to get better results comparing with this one like. Wireless connectivity, DC power, video and audio recording are few of many aspects that can be developed. Not only inside the nest box but an application can be developed to monitor the Nestbox. The application which can be operated through any means of devices like mobile, laptops or tablets to stay check the nest whenever got free time.

The alarm also can be set to aware if system goes wrong. The alarm can also help in hazardous conditions like appearances of prey or any environmental situations. Not only for measuring the physical condition, the program can be further developed to help the living condition of a bird. If needed further assistance can be done like maintaining suitable weather and environment to breed. The physical condition of the bird also can be checked by placing weighing machine. If needed food storage can also be added in severe environmental conditions to help in survival of bird.

All in all, taking the idea of this thesis as reference, the study can be performed to different species. To study various creatures may acquire different infrastructures according to their natural habitat but this concept can play a significant role in preservation of wildlife.

## **11 Conclusion**

The main objective of the whole concept was to develop an advanced prototype of Nestbox. The sample box which is able to study temperature, humidity, air quality and monitor the bird's activities. Along with this, the project should be cost efficient and simple

to study the result. We were able to meet most of the aim. The final data result from microcontroller was compared with test chamber, and with real world test, outcome was satisfactory. Due to factors like time and cost limitation, availability of infrastructures, the final product ready to apply in field could not be completed but the project achieved its core goal.

Since this project was one of a kind, lot of new things were learned. Many challenges were faced during the working process but most of them were resolved. With more study and facilities, this project has lot of scope of improvement within itself or it can be ground base for complete new design. The various part of the project was dealt with good background research which helped to finish the work smoothly. With the concept of making good prototype to study the temperature, humidity, air quality and activities of bird, the hardware and software part were chosen wisely to give the long-term result with more accuracy. This thesis was to be used for daily basis so every part are explained and approved.

After installation of final prototype, the conclusion of the project was regarded as a success. As this thesis is an open field application project, many more ideas can be added to deal with nature and its challenges.

## References

- [1] z. romano, "monitoring falcons with intelligent nestbox," 24 6 2013. [Online]. Available: <https://blog.arduino.cc/2013/06/24/monitoring-falcons-with-intelligent-nests/>. [Accessed 10 4 2017].
- [2] l. ada, "Adafruit," 29 7 2012. [Online]. Available: <https://learn.adafruit.com/tmp36-temperature-sensor/overview>. [Accessed 27 3 2017].
- [3] codebender\_cc, "Instructables," [Online]. Available: <http://www.instructables.com/id/How-to-use-DHT-22-sensor-Arduino-Tutorial/>. [Accessed 1 4 2017].
- [4] uugear, "uugear," [Online]. Available: <http://www.uugear.com/portfolio/dht11-humidity-temperature-sensor-module/>. [Accessed 16 03 2017].
- [5] E. hub, "Electronic Hub," [Online]. Available: <http://www.electronicshub.org/ir-sensor/>. [Accessed 16 03 2017].
- [6] good4deal999, "ebay," [Online]. Available: <http://www.ebay.com/itm/Air-Quality-Sensor-MQ-135-Probe-Hazardous-Gas-Ammonia-Sulfide-Detection-Hot-us99-/261831427954>. [Accessed 21 3 2017].
- [7] logitech, "logitech support," [Online]. Available: [http://support.logitech.com/en\\_us/product/hd-webcam-c525](http://support.logitech.com/en_us/product/hd-webcam-c525). [Accessed 2017 21 3].
- [8] Jtagadmin, "Jtag electronics," 2 8 2015. [Online]. Available: <http://www.jtagelectronics.com/?p=75>. [Accessed 3 2017].
- [9] d. g. house, "Dream green house," 11 1 2014. [Online]. Available: <http://www.dreamgreenhouse.com/datasheets/MQ-135/MQ135.pdf>. [Accessed 21 3 2017].
- [10] M. Rouse, "Iot Agenda," 03 2012. [Online]. Available: <http://internetofthingsagenda.techtarget.com/definition/microcontroller>. [Accessed 20 3 2017].

- [11] N. Instruments, "labview," [Online]. Available: <http://www.ni.com/labview/>. [Accessed 22 03 2017].
- [12] S. Hogg, "National Instruments," 16 8 2013. [Online]. Available: <http://www.ni.com/newsletter/51141/en/>. [Accessed 22 3 2017].
- [13] SM, "ARDUINO," 7 09 2015. [Online]. Available: <https://www.arduino.cc/en/guide/environment>. [Accessed 22 3 2017].
- [14] jayant, "CIRCUIT DIGEST," [Online]. Available: <https://circuitdigest.com/electronic-circuits/ir-sensor-circuit-diagram>. [Accessed 23 04 2017].

```

#define DHTTYPE DHT22 //The DHT11 and DHT22 has same code for operation, but they take different values different from
//library, hence the DHT22 type of sensor is defined

DHT dht(DHTPIN, DHTTYPE);

int sensorPin = A1; //The output of the MQ-135 sensor is connected to A1 pin of arduino.
//the output value obtained is integer

int sensorValue = 0; //the output value of MQ-135 sensor is obtained as integer value

int RawValue = 0; //raw voltage obtained from TMP36. which is in millivolts. obtained as integer value

const int analogIn = A0; //The output of TMP36 sensor is connected to analog input A0 of arduino.
//analog value (mV) received is integer

double Voltage = 0; //the output voltage(V) in the in decimal form

double tempC = 0; //Temperature value is dispalyed in decimal form as well

String in, out; //total representing entry of obstacle.it is set to be 0 at beginning

int total=0; //total representing entry of obstacle.it is set to be 0 at beginning

int total1=0; //total1 representing exit of obstacle.it is set to be 0 at beginning

int LED = 13; // Use the onboard Uno LED

int isObstaclePin = 4; // the output pin of one IR sensor module is connected to digital pin 4 of arduino.
//This is our input pin for indicating if there is bird inside or not.this sensor may or may not be used according
//to the desire of the project

int isObstacle = HIGH; // HIGH MEANS NO OBSTACLE,is the IR sensor module do not sense anything, the digital output is 1.
//if it senses something, the output becomes LOW

void setup() //initialiazng the input pins and variables
{
  pinMode(8, INPUT); //for IR sensor module
  pinMode(7, INPUT); //for IR sensor module
  pinMode(LED, OUTPUT); //for LED
  pinMode(isObstaclePin, INPUT); //initialiazng the pin 4
  Serial.begin(9600); //initialiazng the serial monitor
  dht.begin(); //initialiazng the DHT sensor library
}

void loop() //running the loop continuously until the microcontroller is stopped or reset
{
  sensorValue = analogRead(sensorPin); //reads the analog voltage value (mV) from MQ-135 sensor
  float h = dht.readHumidity(); // Reads humidity value from DHT22
  float t = dht.readTemperature(); // Reads temperature as Celsius from DHT22 (the default)
  float tf = dht.readTemperature(true); // Check if any reads failed and exit early (to try again)

  Serial.print("\n"); //prints new line
  Serial.print("°C = "); //prints '°C' after temperature value
  Serial.print(tempC,1); //prints temperatuere value
  Serial.print(" "); //leaves two character space between previous and next value
  Serial.print(" H "); //prints Humidity value
  Serial.print(h);
  Serial.print(" ");
  Serial.print(" T "); //prints temperatuere value
  Serial.print(t);
  Serial.print(" ");
  Serial.print(" F "); //prints temperatuere value in Fahrenheit
  Serial.print(tf);
  Serial.print(" ");
  Serial.print(total); //prints total entry integer value
  Serial.print(" ");
  Serial.print("En"); //prints En. meaning Entry after 'total' value
  Serial.print(" ");
  Serial.print(total1); //prints total exit integer value
  Serial.print(" ");
  Serial.print("Ex"); //prints Ex. meaning Exit after 'total1' value
  Serial.print(" ");
  Serial.print(sensorValue); //prints analog output value of MQ-135 sensor
  Serial.print(" ");

```



