

# CFD MODELING OF AIRFLOW IN A KITCHEN ENVIRONMENT

Towards improving energy efficiency in buildings

Srujal Shah & Kari Dufva



Kaakkois-Suomen  
ammattikorkeakoulu

Srujal Shah & Kari Dufva

# CFD MODELING OF AIRFLOW IN A KITCHEN ENVIRONMENT

Towards improving energy efficiency  
in buildings



ETELÄ-SAVON  
MAAKUNTALIITTO



Euroopan unioni  
Euroopan sosiaalirahasto

Vipuvoimaa  
EU:lta  
2014–2020

**XAMK TUTKII 1**

SOUTH-EASTERN FINLAND UNIVERSITY OF APPLIED SCIENCES  
MIKKELI 2017

© Authors and South-Eastern Finland University of Applied Sciences

Cover picture: Pixabay, CCO Public Domain

Cover layout: Mainostoimisto ILME

Layout and printing: Grano Oy

ISBN: 978-952-344-021-0 (nid.)

ISBN: 978-952-344-022-7 (PDF)

ISSN 2489-2459 (nid.)

ISSN 2489-4575 (verkkojulkaisu)

[julkaisut@xamk.fi](mailto:julkaisut@xamk.fi)

# PREFACE

The building sector accounts for a large fraction of total energy consumption. Thus, there is a need to find methods for improving the energy efficiency of homes and houses. Among all the building services, heating, ventilation and air conditioning (HVAC) systems play an important role in building energy use. In HVAC, proper ventilation is very important because it helps in controlling the indoor air quality and providing thermal comfort. Computational fluid dynamics (CFD) is a highly used tool to predict the design, function and analysis of ventilation systems. This research report presents a computational model in conjunction with laboratory tests for better understanding of the indoor climate of kitchen environments.

A test room located at South-Eastern Finland University of Applied Sciences in Mikkeli was chosen for the case study. A kitchen hood was installed in the room. The purpose of the hood was to allow mixing of the air coming through the supply inlets with the contaminants in the kitchen and effectively remove those contaminants through the outlets in the hood. In the experimental measurements, CO<sub>2</sub> was used as a tracer gas and its mixing with the air was studied. CFD-predicted distribution of the tracer gas around the room, using various airflow rates for the air and CO<sub>2</sub>, was compared with the experimental measurements of the CO<sub>2</sub> concentrations at different locations in the room. Comparison between the experimental and CFD results showed that computer simulations have great potential in studying airflows in ventilated spaces when applied in the proper way.

It was observed that ventilation airflow rates have a large effect on the overall airflow distribution in the indoor environment. When the airflow rate is unnecessarily high, energy is wasted. A higher airflow rate does not necessarily help to remove pollutants from the kitchen environment and also increases the energy cost. Instead, a lower airflow rate helps with proper mixing of the air and results in a lower energy cost. However, the determination of an optimal airflow rate that is energy-efficient and provides acceptable indoor airflow

quality needs further research. The research conducted in this project will be useful for professionals working on the design and operations of commercial kitchen hoods.

The authors would like to acknowledge the CSC–IT Center for Science Ltd., Finland for providing the ANSYS software and allowing the use of their computational resources. Finally, the authors are grateful to the Regional Council of South Savo, Jeven Ltd. and Iloxair Ltd. for providing funding to conduct this research.

**Authors:**

*Srujal Shah*

*Kari Dufva*

Mikkeli 2017

# CONTENTS

1 INTRODUCTION .....	8
2 CONSTRUCTION LEGISLATION .....	12
3 INDOOR AIR QUALITY .....	14
4 LITERATURE REVIEW .....	16
4.1 CFD modeling in building services.....	16
4.2 CFD modeling in kitchen environments.....	20
4.3 CFD modeling of kitchen hoods .....	20
5 MODELING AND SIMULATIONS .....	22
5.1 Geometry and mesh of the test room.....	22
5.2 Experimental measurements.....	26
5.3 CFD model.....	28
5.4 Fluid Properties .....	32
5.5 Boundary conditions.....	32
5.6 General guidelines for performing simulations .....	33
5.6.1 Computational mesh.....	34
5.6.2 Modeling.....	34
5.6.3 Boundary conditions.....	35
5.6.4 Numerical procedure.....	35
5.7 Simulations.....	36
6 RESULTS .....	38
6.1.1 Comparison of CFD results with experimental measurements.....	38
6.1.2 Carbon dioxide distributions.....	39
6.1.3 Comparison of different mole fractions of tracer gas .....	40
7 IMPROVING BUILDING ENERGY EFFICIENCY.....	42
7.1 Increasing energy efficiency and improving indoor air quality.....	42
7.2 Effect of the heat source on the hood .....	45
8 DISCUSSION .....	47
9 SUMMARY .....	50
REFERENCES.....	52

# 1 INTRODUCTION

The demand for energy and its supply is one of the biggest challenges in the world today. Population growth, an expanding economy and a quest for improved quality of life have led to further increase in energy demand (Harish and Kumar, 2016). In meeting energy demand, consumption of fossil fuels such as oil, gas and coal has indirectly affected water and air due to pollution. The increase in pollution has already increased the concentrations of greenhouse gases in the earth's atmosphere, which has a direct effect on global warming. Limited use of renewable energy options and wastage of energy are also some of the factors restricting the smooth supply of energy. Rapidly growing world energy use has raised concerns over supply difficulties, exhaustion of energy resources and huge environmental impacts such as climate change (Pérez-Lombard et al., 2008).

Thus, in order to produce enough energy for its ever-increasing consumption demands, we have posed a great threat to the environment. We cannot prevent climate change anymore, but its consequences can be delayed by using better technologies. Countries across the world are working together to make strategies for developing energy-efficient techniques. Energy efficiency is an effort to reduce the amount of energy required, possibly achieved through adopting more efficient technology. This includes more usage of renewable energy sources and utilizing energy in an appropriate way. Awareness among the public is also equally important, so that unnecessary usage of energy can be reduced.

The building sector represents a large fraction of total energy consumption. In the U.S. and Europe, buildings consume more than 40% of total energy (Cao et al., 2016). Due to the enhancement of building services and living comfort, along with the amount of time spent indoors, the levels of building energy consumption have increased (Pérez-Lombard et al. 2008). Energy consumption in buildings stems from lighting and electrical appliances as well as from heating, ventilation and air conditioning (HVAC) systems. For example, in countries experiencing cold weather, people tend to spend more time indoors rather than outdoors, therefore increasing energy consumption. Thus, there is a need to reduce energy consumption, and, in fact, according to the Directive 2010/31/EU (Energy Performance of Buildings Directive), all new buildings of the European Union member states must be nearly zero-energy buildings by

the end of 2020. This sets challenges to building engineers for the development of better designs, constructions and operations, while maintaining thermal comfort and acceptable indoor air quality.

The building services sector must consider efficient steps via which energy consumption can be reduced and energy efficiency improved. HVAC systems play an important role in how the total energy of buildings is used. In HVAC, proper ventilation is very important because it helps in controlling the indoor air quality (IAQ). This mainly consists of fans and ducts that supply fresh air from the exterior, and replace polluted air from the interior. If a proper ventilation system is not installed, it can lead to poor indoor air quality. An efficient ventilation system is not only necessary from an engineering point of view, but also has an impact on health, as we tend to spend most of our time indoors. In addition, the indoor environment can easily be vulnerable to air pollutants. Thus, a proper ventilation system is needed to efficiently remove these pollutants from the indoor environment. To summarize this, Chenari et al. (2016) discusses steps by which sustainable, energy-efficient and healthy ventilation strategies can be applied.

Ventilation is used in buildings to create indoor environments with acceptable air quality and thermal comfort using parameters such as air temperature, air velocity, and humidity. In addition, the use of a proper ventilation system is important, as it is one of the factors responsible for building energy consumption. Improving ventilation systems is not only necessary in fostering energy efficiency but also in providing a better indoor climate. Designing ventilation systems for buildings requires a suitable tool to predict their performance. Different tools to predict ventilation performance, such as analytical, empirical, and CFD, are presented in the literature (Chen, 2009; Chen et al., 2010).

The main aim of this work is to study the ventilation of indoor airflow systems such as in a kitchen environment. The kitchen is an important entity in the building systems because it is a place where pollutants are generated due to cooking activities. If these pollutants are not effectively removed from the kitchen, then they can spread to other rooms and their presence can raise risk of health problems. Thus, the kitchen environment is considered in order to get a better understanding of the distributions of the pollutants, and the efficiency of the ventilation system can be studied. In this study, a test room located at South-Eastern Finland University of Applied Sciences was selected as a case study. In the test room, air was supplied to the room through the installed



ventilating kitchen hood. Carbon dioxide was used as a tracer gas and its mixing with the air and water vapor was studied using CFD methods.

CFD is a powerful tool routinely used to predict the design and function of ventilation systems. Many papers can be found in the literature that have shown the importance of CFD in the studies of ventilation systems (Chen, 2009; Li and Nielsen, 2011; Nielsen, 2004; 2015). ANSYS® Release 16 software was used to perform CFD modeling and to analyze the airflow in a kitchen. Temperature effect was taken into account using a heat source. The distribution of the tracer gas around the room, using various flow rates for the air and CO<sub>2</sub>, was simulated. Comparison of different turbulence models was performed. Additional simulations were also performed to test the effect of different values of mole fractions for the CO<sub>2</sub> and its distribution in the domain.

From a modeling point of view, the kitchen is a relatively complex environment, and the experimental results are important in validating the computational model for trustworthy results. In this study, experimental measurements were conducted using three sensors located at different places in the room to measure the CO<sub>2</sub> concentrations. Comparison between the experimental and CFD results shows that computer simulations have great potential in studying airflows in ventilated spaces when applied in the proper way. This type of CFD simulation is useful in studying, for example, distribution of different pollutant gases emitting from cooking activities.

The main purpose of ventilation is to remove contaminants and create good indoor air quality that reduces the risk of health problems. It is therefore important that a sufficient ventilation rate be used to maintain acceptable indoor air quality. If the ventilation rate is too low, energy can be saved but the indoor air quality is not maintained because the pollutants are not properly removed from the kitchen. If the ventilation rate is more than required, it can improve the indoor air quality, but it results in unnecessary energy consumption.

In this report, the contribution of different chapters is summarized as follows. The introduction points out the general aim of the project: to study the modeling of airflow in kitchen environments and how the energy efficiency of buildings can be improved. A literature review on CFD simulations for building services, kitchens and kitchen hoods is carried out to illustrate the role of CFD in building services. CFD modeling and simulations of airflow in a kitchen environment are presented as a case study. CFD results are presented for different

ventilation airflow rates, turbulence models, and different concentrations of the tracer gas. Different ventilation methods to improve energy efficiency as presented in the literature, as well as how CFD supports the findings of the ways to improve energy efficiency by lowering the ventilation airflow rate are presented. In the end, a discussion is carried out regarding the CFD modeling of ventilation systems, design of the modeled kitchen hood, and general remarks regarding energy efficiency and indoor air quality.

The main tasks of this work can be summarized as follows:

- A literature review on CFD modeling and simulations is presented for indoor environments such as buildings and kitchens.
- CFD modeling and simulations were performed to study the ventilation of airflow in a kitchen environment.
- Detailed geometrical model of the kitchen hood was prepared for simulations.
- Experimental measurements for study of airflow and its mixing with the tracer gas (carbon dioxide) and water vapor were performed.
- Comparison of experimental measurements and CFD simulations showed good agreement.
- Some of the strategies to improve energy efficiency of ventilation systems as presented in the literature are discussed.
- The findings of the CFD predictions support the strategy of reducing ventilation rate in order to improve energy efficiency.

## 2 CONSTRUCTION LEGISLATION

The Energy Performance of Buildings Directive (EPBD) 2010 and Energy Efficiency Directive 2012 cover the EU's main legislation regarding building energy consumption. In these frameworks member states are committed to reducing greenhouse gas emissions. These directives set requirements and targets for building energy consumption and efficiency calculations. At the national level in Finland, main documents and regulations can be found in the National Building Code of Finland. For the energy efficiency and indoor climate sector, important documents are Energy Efficiency of Buildings, Regulations and Guidelines D3 (2012), and Indoor Climate and Ventilation of Buildings, Regulations and Guidelines D2 (2012) (Ministry of the Environment 2017).

At the moment, the legislation is changing and new proposals for EPBD have been made in 2016 (European Commission, Energy 2017). The objectives of the new proposal are focused on accelerating the renovation of existing buildings, creating a vision for a decarbonized building stock by 2050, and accelerating the integration and use of ICT and smart technologies (COM (2016) 765 final). In Finland, the regulations are also changing and preparation of the energy efficiency section and the regulations for indoor climate and ventilation (D2) of new buildings is ongoing.

In order to further comparison of different products and to promote the environmental performance of the products, the EU has legislation for Ecodesign and energy labeling. The labeling requirements for individual product groups are created under the EU's Energy Labelling Directive. The Ecodesign Directive defines the minimum mandatory requirements for the energy efficiency of the products included. Both directives are complemented by harmonized European standards. (European Commission, Ecodesign 2017)

One way to improve the energy efficiency of an air conditioning system is to focus on necessary ventilation and fan airflow control. Regarding legislation, the energy label for household electric hoods became mandatory starting in 2015. The energy efficiency rating was tightened at the beginning of 2016 so that the energy efficiency classes of devices placed on the market after 1 January 2016 are A + ... F. In future, the energy efficiency grading of hood fans will change in stages so that after 1 January 2018 the rating should be A ++ ... E and 1.1.2020

A +++ ... D (Motiva 2016). However, this labeling does not tell much about the capture efficiency of the hood, and comparison of overall performance is not straightforward. For this reason, it has been considered important to study the relation between the minimum airflow rate and room contamination with pollutants.

### 3 INDOOR AIR QUALITY

The human body, from the very beginning of its life, is exposed to air, and so it is very important that the air around us is clean enough. Since most of our time is spent indoors, it is extremely necessary that the indoor air is free from pollutants. The term “indoor air” refers to the air that is inside confined spaces, such as homes, offices, schools, etc. The quality of air around us plays an important role in our lives. The term “indoor air quality” (IAQ) generally refers to the amount and type of contaminants present in the air. There are well-defined ASHRAE standards, which give information about the permissible quantity of pollutants in the air. It also essentially refers to the air quality within and around buildings, which relates to the health and comfort of building occupants. People normally tend to believe that only improving the quality of outdoor air is important since most of the major pollutant sources exist in the outdoor environment. People believe that the indoor environment is safe and the air they breathe is free from pollutants.

Over the last 30 years, there have been significant developments both in the intensity with which indoor air quality (IAQ) is being challenged and in the understanding of various parameters that influence IAQ (Tham, 2016). The paper of Tham also further presents that the indoor environment is dynamic and affected by several parameters, such as materials (furniture and fabrics), HVAC systems, and presence of human beings. All these parameters bring impurities into the air and makes the air polluted. These parameters are parts of the indoor environment that cannot be neglected and, therefore, a more holistic approach is needed to efficiently remove the impurities from indoor air.

Several studies can be found in the literature that have shown the importance of indoor air quality on health. The health effects of household air pollution are aggravated when polluted air takes a long time to be flushed out of the cooking area, which is directly related to the indoor ventilation rate. Jones (1999) presented a large number of emission sources that can lead to indoor air pollution, and these can cause significant effects on health. Sundell (2004) mentioned that indoor air was believed to be a major environmental factor in the past, but then other factors, such as outdoor air quality, energy consumption, and sustainable buildings, became dominant. It is true that a major environmental concern today regards climate change due to outdoor air pollution, but indoor air quality is not something that can be ignored.

Many studies have focused on the health issues stemming from lack of efficient ventilation techniques. Especially in Asian countries, this problem is more demanding as cooking habits and lifestyle play an important role in health. Lai and Ho (2008) mentioned in their paper that Chinese cooking includes frying or deep frying food while preparing in a wok and it requires oil. Thus, high temperatures and such cooking practices generate a large amount of smoke fumes from oil that nucleates to form particles. Such types of oil fumes generated from cooking increase the risk of lung cancer in Chinese women (Metayer et al., 2002). In Taiwan, even though the percentage of women smoking is relatively small, females still have a high prevalence of lung cancer (Yu et al., 2015). In India, this problem is even more severe as cooking from biofuels is a common practice. The use of biofuels for cooking generates a lot of pollutants that have a great adverse effect on health in relation to lung and respiratory functions (Dutt et al., 1996).

In developed countries, concern and awareness regarding indoor air quality can still be relevant. Due to cold weather conditions, airtight buildings have restricted the natural flow of air. In such circumstances, proper ventilation systems must be present for effective removal of pollutants from the air. Health problems such as allergies, airway infections and cancers are some of the consequences of poor ventilation systems (Sundell, 2004).

In addition to indoor air quality, the thermal comfort of the occupant within the indoor environment is also important. Thermal comfort essentially means the condition of mental satisfaction with the thermal environment. In practice, it is not necessary to provide thermal comfort that satisfies each person. Instead, a level of thermal comfort that can satisfy the majority of occupants should be provided. The indoor thermal environment also influences the perception of air quality and can directly or indirectly affect occupant health.

It is a known fact that there are differences in factors such as climatic conditions, lifestyles, and building design. Thus, the strategies and methods for maintaining suitable indoor environment conditions such as indoor air quality and thermal comfort are different for different countries as well.

## 4 LITERATURE REVIEW

Due to the advancements in high performance computing facilities, computational simulations are gaining popularity. Nowadays, computational fluid dynamics (CFD) is a powerful tool routinely used in the design, development, analysis and understanding of various systems in industries. The increase in computational resources and development of powerful software have allowed researchers and engineers to carry out accurate analysis of air movement, which is often not possible with expensive measurements. Indoor airflow modeling has been possible using CFD that not only predicts fluid dynamics, but also estimates air quality and thermal comfort.

### 4.1 CFD modeling in building services

As mentioned earlier, HVAC plays an important role in overall building energy use. In HVAC, proper assessment of ventilation is important in building service applications. Ventilation refers to the process of introducing fresh outside air and replacing indoor air. Ventilation is especially important because it provides a thermally comfortable environment and acceptable air quality. Actually, ventilation is also a factor affecting a building's energy use. Study of indoor air is of interest because we spend a large amount of our time indoors. Chen (2009) and Chen et al. (2010) presented several tools that are used to predict ventilation performance in buildings, such as analytical models, empirical models, small-scale experimental models, full-scale experimental models, multizone network models, zonal models, and CFD models. Each of these tools are briefly discussed below based on the studies in the above research. Much attention is given to CFD models, and this is the modeling approach used in this study.

The analytical models are derived from the fundamental equations of fluid dynamics and heat transfer. They use a simplified approach by making assumptions so that a solution can be obtained. They do not predict the detailed flow information, but instead these models are used to obtain a rough estimate of ventilation performance. The empirical models are quite similar to the analytical models. These types of models are not only developed from the fluid dynamics and heat transfer equations, but also from the experimental measurements or advanced computer simulations.

Small-scale experimental models use measuring techniques to predict or evaluate ventilation performance on a reduced scale of the buildings or rooms. Certainly it is convenient to use a small-scale model in comparison to a full-scale building. In order to achieve flow similarity between a small-scale experimental model and a building or room, important dimensionless flow parameters in the small-scale model such as Reynolds number, Grashof number, Prandtl number, etc. must remain the same as in the building or room. Due to the complexities of scaling down complex geometry, small-scale experimental models are mainly used to validate analytical, empirical or numerical models.

Full-scale experimental models are used quite similarly to small-scale models. Full-scale experimental models can be further classified into two categories: laboratory experiment and in-situ measurements. Laboratory experiments often use an environmental chamber to mimic a room or a single storey building with several small rooms. In-situ measurements are more often used to evaluate the performance of existing buildings. However, these are generally expensive and time consuming. The current trend seems to be to use full-scale experimental models of laboratory equipment and in-situ measurements to obtain data for validating CFD models, and then using the validated computer models to conduct the predictions of ventilation performance or to design ventilation systems.

Multizone models are mainly used to predict air exchange rate and airflow distributions in buildings with or without mechanical ventilation systems. These models solve mass, energy and species conservation equations. These models assume uniform air temperature and uniform species concentrations in a zone. Furthermore, the momentum effect is not considered as the air is assumed to be in a quiescent state. Wang and Chen (2008) showed that making these assumptions can lead to errors. They proposed solving this problem by coupling a multizone program, CONTAM, with a CFD program.

Zonal models are developed in comparison to the multizone models, since mixing assumption is not valid for large spaces. Zonal models are based on measured airflow patterns or on solving mass and energy equations. In zonal models, for a three-dimensional space, the room is discretized into a limited number of cells, and the air temperature is calculated in each of the cells. If the flow momentum is strong, a zonal model does not predict accurate results, because it does not consider the momentum equation.



With the ever-increasing computational speed and better visualization capabilities, computational fluid dynamics (CFD) models are increasingly gaining popularity in studying ventilation performance in buildings. CFD refers to the analysis of systems involving fluid flow, heat transfer and phenomena such as chemical reactions using computer-based simulation (Versteeg and Malalasekera, 1995). A CFD simulation involves three major steps: pre-processing, solver and post-processing. Pre-processing refers to the definition of the problem and creation of the flow domain using geometry construction software, and then discretizing it into a number of grid points (mesh generation). The next step is the solver, which refers to setting of the model, fluid properties, boundary conditions and solution of the flow equations. This step involves use of a solver to solve the fluid flow equations numerically. This can be done by discretization of the differential equations around each grid point to obtain the algebraic equations of the flow variables that are solved using the iterative procedure. Post-processing refers to the visualization of the flow variables once the solution is converged and interpretation of the predicted results. A schematic of the steps in a CFD simulation from pre-processing to post-processing is shown in Figure 4.1.

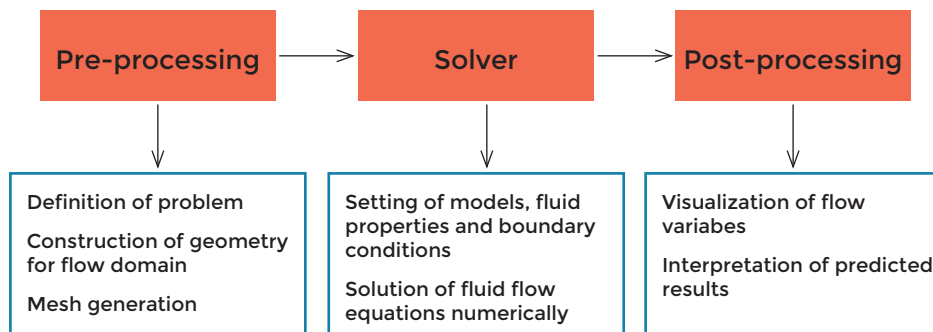

FIGURE 4.1. Steps in a CFD simulation from pre-processing to post-processing.

Chow (1996) demonstrated the application of CFD in building services engineering, and illustrated different systems such as fire engineering, prediction of smoke movement in large enclosures, sprinkler and hot air interaction, combustion with a simple chemical reaction system approach, HVAC design and air-conditioned gymnasiums and offices. Fletcher et al. (2001) did a similar type of study and showed the importance of CFD as a building services engineering tool. In their work, different examples showing applications of CFD were presented, including contamination and thermal comfort in a room, pollution control in a car park, natural ventilation and thermal comfort with

solar heating, the heat-stacking effect in a high-rise air wall, and thermal plumes in a high-rise apartment building. Zhai (2006) showed various applications of CFD in building design such as in site planning, ventilation, and pollution dispersion and control. Norton and Sun (2006) gave a detailed review on the use of CFD as a design and analysis tool for the food industry.

CFD has gained importance and emerged as a useful tool for the prediction of air movement in ventilated spaces (Nielsen, 2015). CFD numerically solves the conservation of mass and momentum (Navier-Stokes equations) for the isothermal flow conditions. It solves the energy transport equation when a heat source is involved, which demands calculation of the temperature distribution in the flow domain. Most often CFD studies involving indoor air also solve the species transport equation to determine contaminant distribution. Indoor airflows are often turbulent, and thus require a turbulence model to be solved simultaneously. The solutions of these equations give the distributions of air velocity, temperature, pressure and contaminants present in the computed space.

In general, modeling and simulation of buildings is challenging. First of all, the design itself is relatively complicated due to the large number of entities in it. Secondly, the flow domain of the whole building is very complex, and hence, simulations require a significant amount of user experience. Also, a large amount of data is required to incorporate proper boundary conditions. Researchers and engineers have mainly undertaken simulations of individual units within buildings. For example, an individual room or a set of rooms is usually simulated. Lee et al. (2002) studied dispersion of indoor contaminants using CFD for two different air inlet velocities in a workroom. Posner et al. (2003) studied the indoor airflow in a model room and showed that obstacles in the room can have a significant effect on the airflow motion in the room. Khan et al. (2006) did CFD simulations to study the effects of inlet and exhaust locations and gas densities on contaminant concentrations. Bulińska et al. (2014) performed CFD simulations in a room with one sleeping person to find the measuring area of mean CO<sub>2</sub> concentration. Rojas et al. (2015) studied the mixing of living room air and bedroom air while using supply air nozzles only in bedrooms. Gilani et al. (2016) did sensitivity analysis for CFD simulations of a test room using different grid sizes, turbulence models, discretization schemes and convergence criteria. Ning et al. (2016) used CFD to simulate airflow field, mean age of air and CO<sub>2</sub> distributions inside a bedroom using different heights of conditioned air supply outlet. Thus, several papers are available in the literature showing different applications of CFD modeling in indoor environments.

## 4.2 CFD modeling in kitchen environments

Kitchens play a very important role in building services, as they are the main source from which contaminants are generated, due to the cooking process. These contaminants significantly affect indoor air quality and have a serious impact on our health. The ventilation system in the kitchen plays a crucial role in facilitating comfortable conditions and it is of prime interest to ensure that cooking contaminants are removed from the kitchen. Several CFD studies are presented in the literature that essentially focuses on the calculation of the flow field, temperature distribution and pollutant concentrations in kitchen environments. This type of study helps in understanding of the behavior of airflow and accumulation of pollutants. This further helps in determination of proper design and function of ventilation systems.

Chiang et al. (2000) did CFD analysis to investigate indoor air environment via flow fields, temperature and air contaminant distributions in conventional kitchens. Chen et al. (2001) modeled pollutants arising from unflued combustion in a kitchen environment. Kosonen (2006) studied the effect of thermal plumes on the performance of ventilated ceilings in commercial kitchens. Lai and Ho (2008) studied the spatial concentration variation of cooking-emitted particles in a residential kitchen. Saha et al. (2012) compared experimental and computational investigation of indoor air quality inside several community kitchens in a large campus. Gao et al. (2013) studied the dynamic intake fraction of cooking-generated particles in the kitchen. Zhou et al. (2016) studied the pollution control in residential kitchens based on the push-pull ventilation system.

Various CFD programs are used in the literature to simulate airflow in kitchens. For example, Chen et al. (2001) used ANSYS® CFX, Lai and Ho (2008) and Saha et al. (2012) used ANSYS® Fluent, and Kosonen (2006) used AirPak for performing their CFD simulations.

## 4.3 CFD modeling of kitchen hoods

The cooking process generates pollutants that must be removed from the kitchen. If ventilation is not adequate, then these pollutants may also travel to adjoining rooms. These can be unpleasant not only to the kitchen's occupants but also to occupants in other rooms. In general, the modern kitchen contains

a hood, which helps to remove contaminants from the kitchen. As described by Abanto and Reggio (2006), a hood can be seen as an elementary turbomachine that extracts a volume of air from a given environment under standard operating conditions. Normally, hoods are located above the stove. It is very important that an appropriate exhaust rate be applied so that it can definitely remove the contaminants generated by the cooking process. Thus, in all, it demands an efficient ventilation system through which incoming and outgoing air flows smoothly.

There are some studies presented in the literature that deal with CFD modeling of kitchen hood systems. Abanto and Reggio (2006) studied the numerical investigation of the flow in a kitchen hood system. Lim and Lee (2008) studied the flow field, temperature and concentration distribution when changing the shape of the separation plate of the kitchen hood system.

# 5 MODELING AND SIMULATIONS

Significant development and improvement has taken place in CFD and its application in science and engineering during the last 40 years. Nowadays, many engineering flow problems are analyzed and predicted using CFD. Modeling is an important feature of the system analysis in which we actually represent the complex phenomena through virtual engineering. CFD is less about getting estimates for the flow variables than it is about our understanding of the behavior of the flow phenomena. CFD is in itself a complex field, having several parameters that need to be carefully considered.

As perceptively quoted by Sørensen and Nielsen (2003), computational fluid dynamics refers to two independent disciplines, ‘fluid dynamics’ and ‘computational’. Fluid dynamics refers to the selection of governing equations, boundary conditions and fluid properties. Computational refers to the selection of methods for solving the governing equations, including mesh, discretization schemes and convergence errors. Many errors can occur in prediction due to choice of numerical methods, chosen models, relevant boundary conditions and possibly due to user experience (Peng et al., 2016). Generally, the solution procedure for all the flow problems using CFD is problem dependent. In the book “Computational Fluid Dynamics in Ventilation Design” prepared by REHVA: Federation of European Heating and Air-conditioning Associations, general guidelines are described which must be followed by the user to ensure the quality of the CFD simulations (Nielsen et al., 2007).

The CFD modeling and simulations in this work were conducted with the software ANSYS® Workbench 16 using the ANSYS® Fluent fluid flow systems. This software provides multiple tools for performing simulations, which the software covers from geometry generation to post-processing of the predicted CFD results. In this chapter, we discuss the geometry and mesh of the test room, boundary conditions, CFD model and numerical simulations.

## 5.1 Geometry and mesh of the test room

The geometry used in this work was built based on the dimensions of the actual test room located at South-Eastern Finland University of Applied Sciences. The

length of the room is 6.2 m, height 2.8 m and width 2.75 m. The room is otherwise empty, and is specially prepared for studying indoor ventilation. An industrial level kitchen hood is installed in the room and it represents a portion of a larger hood assembly.

An air processing unit is located outside the room. It consists of a ventilation system by which the fresh air is allowed to enter the room through the supply air inlets located in the hood and the stale air is removed from the room through the outlets located in the hood. There are two supply air inlets and two outlets located in the hood. Each of the supply air inlets contains multiple inlets through which the air is introduced into the room in different directions. The room has one door and three windows. Figure 5.1 shows the test room with the hood installed.



FIGURE 5.1. The test room located at South-Eastern Finland University of Applied Sciences.

The geometry of the test room was prepared using the software ANSYS® DesignModeler. Figure 5.2 shows the schematic representation of the room with the installed kitchen hood. The schematic also shows the table below the hood. The heat source was kept on the table during the experimental measurements that are described below.

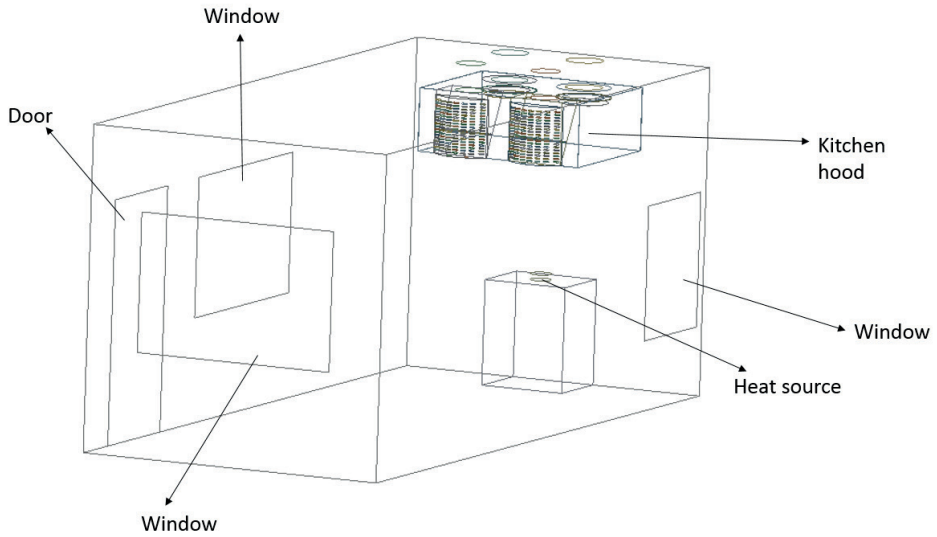

FIGURE 5.2. Schematic of the room with the installed kitchen hood.

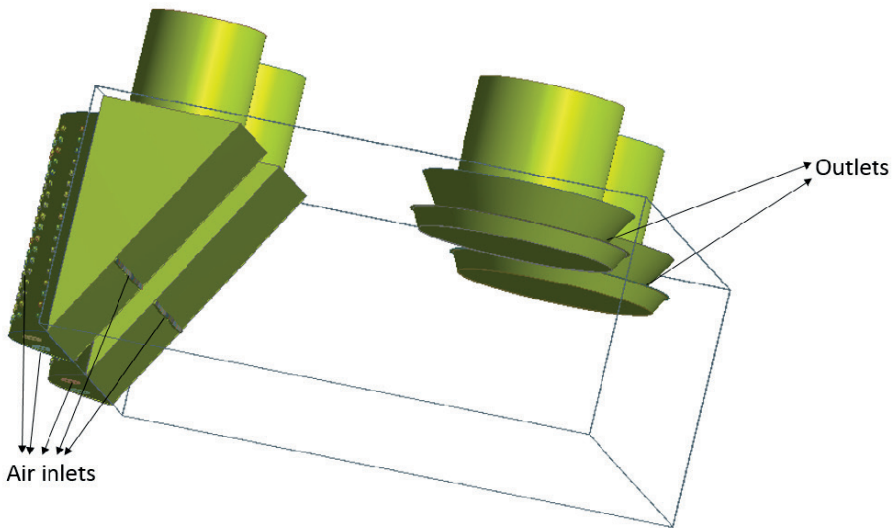

FIGURE 5.3. Detailed hood geometry showing the supply air inlets and outlets.

A detailed hood geometry was prepared in this study, so that it calculates the flow in a detailed manner. The detailed hood geometry prepared for this study is shown in Figure 5.3. As seen from the detailed hood geometry, the air enters the room through multiple air inlets.

The mesh for the geometry was prepared using ANSYS® Meshing. Two types of mesh were prepared for the geometry: the mesh using hex dominant cells and the mesh using tetrahedral cells. Figures 5.4 and 5.5 shows both the types of mesh prepared. A mesh using only hexahedral cells was complicated due to the design of the hood. Thus, a mesh using hex dominant cells was generated. For both the mesh types, the number of computational cells was about 3.7 million.

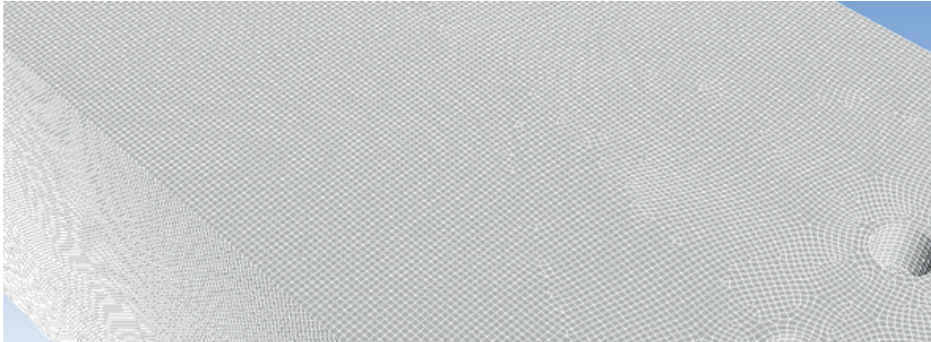

Figure 5.4. Mesh of the test room using hex dominant cells.

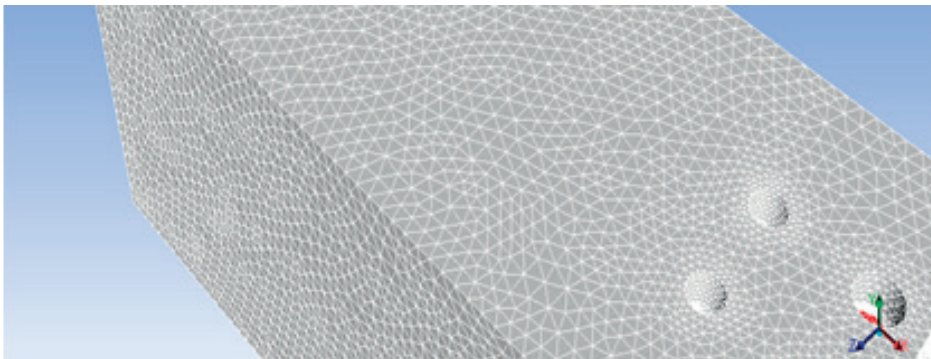

Figure 5.5. Mesh of the test room using tetrahedral cells.



## 5.2 Experimental measurements

As discussed earlier, the cooking process generates lot of heat and pollutants that must be removed efficiently from the kitchen environment. Ventilation is one of the key elements that helps to remove cooking-generated pollutants and consumes some amount of energy in order to perform acceptably. Experimental measurements were carried out to study the mixing of the air with the tracer gas.

To perform this task, air was used as the main gas that was introduced to the room from the supply air inlets. The volumetric airflow rate at the supply air inlets can be calculated with the formula,  $Q = K\sqrt{P_m}$ , where  $K$  is the hood specific supply air coefficient,  $P_m$  is measured pressure difference. For the installed hood in the test room, the value of the supply air coefficient is  $K = 0.192\text{m}^3/\text{hr}$ . Each of the supply air inlets contains a measuring point at which pressure difference can be measured. The instrument used to measure the pressure difference was TSI AirFlow 465P. Thus, the volumetric airflow rate was calculated for both the supply air inlets. During the experimental measurements, the airflow rate of the supply air at the left side inlet was  $0.148\text{m}^3/\text{s}$  and for the right side inlet was  $0.152\text{m}^3/\text{s}$ . This makes a total of  $0.3\text{m}^3/\text{s}$  for both the supply air inlets. The temperature of the air coming from the supply air inlets was  $20^\circ\text{C}$ .

One way to study the mixing of pollutants with the air is to use a tracer gas. Carbon dioxide was used in experimental measurements as a tracer gas. The experimental arrangement of the system was as follows. A box of nearly the same dimensions as commonly available stoves was kept below the kitchen hood. The height of the box was 90 cm, width 75 cm and depth 60 cm.

An induction cooker was placed on top of the box and water was boiled on it in a stainless steel vessel. The power of the induction cooker was 2 kW and the set temperature of the cooker was  $100^\circ\text{C}$ . The source of the tracer gas was kept next to the vessel. Figure 5.6 shows the experimental arrangements for the water in the vessel kept on the induction cooker and the source of the tracer gas kept next to the vessel. The figure also shows the instrument (discussed below) placed in front of the box for measuring the carbon dioxide concentrations. It should be noted that in the modeled geometry, the source was the same for the water vapor from the boiling water as it was for the tracer gas.

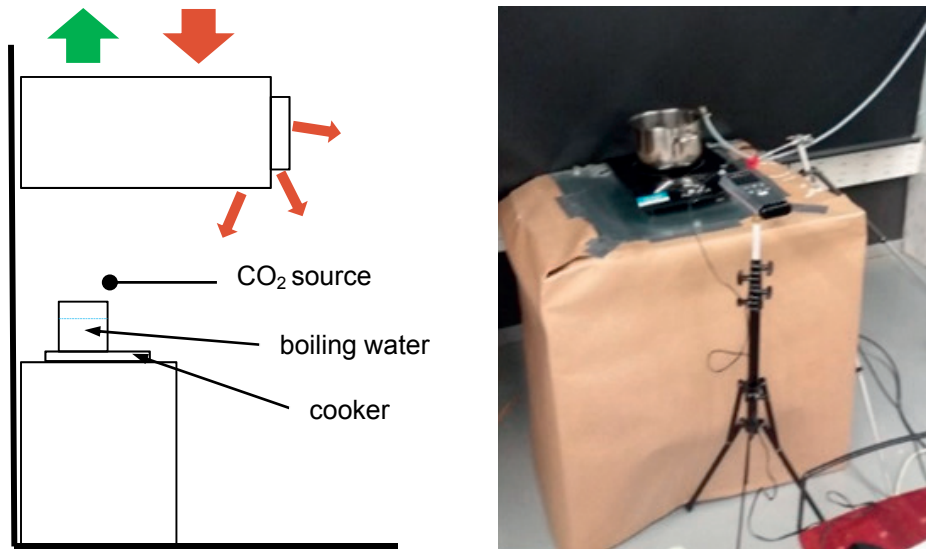

Figure 5.6. The experimental arrangements showing the water in a vessel kept on the cooker and the source of the tracer gas kept next to the vessel.

Three instruments were placed in the room for monitoring the CO<sub>2</sub> concentrations (ppm) at different places in the room. Two of the instruments were Rotronic CP11 and the third instrument was the TSI IAQ-Calc 7535. The locations of these instruments are shown in Figure 5.7. The values were recorded for about 30 minutes.

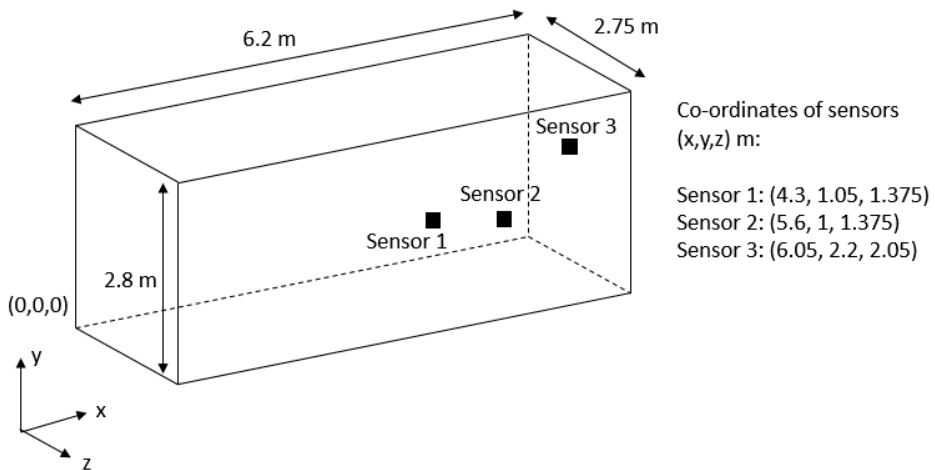

FIGURE 5.7. Locations of sensors for measuring CO<sub>2</sub> (in ppm) in the room.

### 5.3 CFD model

The CFD model in this work is comprised of a 3D, steady, incompressible Navier-Stokes equations with a two-equation turbulence model. The temperature distribution in the domain is computed simultaneously using the Energy Equation. Since we need to analyze the behavior of the tracer gas introduced into the air, a species transport equation is also solved together with the others. The governing equations for the mass, momentum, turbulence, energy and species transport are given in this section.

Ideally, the airflow in the ventilated room is always turbulent. Turbulence in the flow is characterized by eddies of varying length and time scales. Direct numerical simulations to capture the smallest eddies are impossible due to the very large memory requirements. To remedy this problem, the Reynolds averaging is performed over the Navier-Stokes equations leading to the additional terms in the averaged equations that must be modeled. This can be done by defining the flow variables of the instantaneous equations as the sum of mean and fluctuating components. For example, the velocity components,  $i = 1,2,3$  representing co-ordinate directions, can be written as  $u_i = \bar{u}_i + u'_i$ .

The fluctuations are defined in such a way that their time average equals zero. Substituting these values to the Navier-Stokes equations for an incompressible flow (and dropping the overbar for the mean components), we get the equations for the steady state as follows

$$\frac{\partial u_i}{\partial x_i} = 0,$$

$$\frac{\partial}{\partial x_j} (\rho u_i u_j) = -\frac{\partial p}{\partial x_i} + \frac{\partial}{\partial x_j} \left[ \mu \left( \frac{\partial u_i}{\partial x_j} + \frac{\partial u_j}{\partial x_i} \right) \right] + \frac{\partial}{\partial x_j} (-\rho \overline{u'_i u'_j}) + \rho g_i,$$

where  $\rho$  is the density,  $p$  is the pressure,  $\mu$  is the molecular viscosity, and  $g$  is the gravity. To close these equations, the Reynolds stresses,  $(-\rho \overline{u'_i u'_j})$ , must be modeled. One of the most common methods is the use of the Boussinesq hypothesis as given by

$$-\rho \overline{u'_i u'_j} = \mu_t \left( \frac{\partial u_i}{\partial x_j} + \frac{\partial u_j}{\partial x_i} \right) - \frac{2}{3} \rho \kappa \delta_{ij},$$

where  $\mu_t$  is the turbulent viscosity,  $\delta_{ij}$  is the Kronecker delta and  $\kappa$  is the turbulent kinetic energy.

There are several turbulence models available in the literature to model the Reynolds stresses. Zhai et al. (2007) presented a summary of the prevalent turbulence models used in the CFD modeling of air distribution in enclosed environments. Out of the several models available, the  $\kappa - \epsilon$  model and the  $\kappa - \omega$  model are the most common turbulence models used in the CFD simulations on ventilation. There are several studies available in the literature which have used and compared different turbulence models in airflow simulations (Stamou and Katsiris, 2006; Kuznik et al., 2007; Shen et al., 2012). Different studies have revealed that there is no one particular set of turbulence model that can be generally used. In this work, five different types of turbulence model: the standard  $\kappa - \epsilon$  model, the realizable  $\kappa - \epsilon$  model, the RNG  $\kappa - \epsilon$  model, the standard  $\kappa - \omega$  model and the SST  $\kappa - \omega$  turbulence models are compared. More description of the turbulence models can be found in the ANSYS® Fluent Theory Guide (ANSYS, 2014).

The governing equations for all of the abovementioned turbulence models can be found in the ANSYS® Fluent Theory Guide (ANSYS, 2014). However, to familiarize readers with the equations, a complete set of governing equations for the SST  $\kappa - \omega$  turbulence model is given below

$$\frac{\partial}{\partial x_j} (\rho \kappa u_j) = \frac{\partial}{\partial x_j} \left( \Gamma_\kappa \frac{\partial \kappa}{\partial x_j} \right) + G_\kappa - Y_\kappa$$

$$\frac{\partial}{\partial x_j} (\rho \omega u_j) = \frac{\partial}{\partial x_j} \left( \Gamma_\omega \frac{\partial \omega}{\partial x_j} \right) + G_\omega - Y_\omega + D_\omega,$$

where  $\kappa$  represents the turbulence kinetic energy,  $\omega$  represents the specific dissipation rate,  $G_\kappa$  represents the production of  $\kappa$ ,  $G_\omega$  represents the production of  $\omega$ ,  $\Gamma_\kappa$  and  $\Gamma_\omega$  represent the effective diffusivity of  $\kappa$  and  $\omega$ , respectively,  $Y_\kappa$  and  $Y_\omega$  represent the dissipation of  $\kappa$  and  $\omega$  due to turbulence, and  $D_\omega$  represents the cross-diffusion term. The effective diffusivities for the turbulent kinetic energy and the specific dissipation rate are described by

$$\Gamma_\kappa = \mu + \frac{\mu_t}{\sigma_\kappa} \quad \text{and} \quad \Gamma_\omega = \mu + \frac{\mu_t}{\sigma_\omega},$$

where the turbulent viscosity is then calculated by  $\mu_t = \frac{\rho \kappa}{\omega} \frac{1}{\max\left[\frac{1}{\alpha^*}, a_1 \omega\right]}$ , where  $S$  is the strain rate magnitude.  $\sigma_\kappa$  and  $\sigma_\omega$  are the turbulent Prandtl numbers for  $\kappa$  and  $\omega$ , respectively, given by

$$\sigma_\kappa = \frac{1}{F_1/\sigma_{\kappa,1} + (1-F_1)/\sigma_{\kappa,2}} \quad \text{and} \quad \sigma_\omega = \frac{1}{F_1/\sigma_{\omega,1} + (1-F_1)/\sigma_{\omega,2}}.$$

The blending functions  $F_1$  and  $F_2$  are given by

$$F_1 = \tanh\left(\left\{\min\left[\max\left(\frac{\sqrt{\kappa}}{0.09\omega y}, \frac{500\mu}{\rho y^2\omega}\right), \frac{4\rho\kappa}{\sigma_{\omega,2}D_\omega^+ y^2}\right]\right\}^4\right), \text{ where,}$$

$$D_\omega^+ = \max\left[2\rho\frac{1}{\sigma_{\omega,2}}\frac{1}{\omega}\frac{\partial\kappa}{\partial x_j}\frac{\partial\omega}{\partial x_j}, 10^{-10}\right], \text{ and } F_2 = \tanh\left(\left\{\max\left[2\frac{\sqrt{\kappa}}{0.09\omega y}, \frac{500\mu}{\rho y^2\omega}\right]\right\}^2\right),$$

where  $y$  is the distance to the next surface and  $D_\omega^+$  is the positive portion of the cross-diffusion term. The coefficient  $\alpha^*$  dampens the turbulent viscosity causing a low-Reynolds number correction which is given by

$$\alpha^* = \alpha_\infty^* \left(\frac{\alpha_0^+ Re_t / R_\kappa}{1 + Re_t / R_\kappa}\right), \text{ where, } Re_t = \frac{\rho\kappa}{\mu\omega}, R_\kappa = 6, \alpha_0^* = \frac{\beta_i}{3}, \beta_i = 0.072. \text{ It should be noted that in the high-Reynolds number form of the } \kappa - \omega \text{ model, } \alpha^* = \alpha_\infty^*.$$

The turbulence dissipation is modeled as follows

$$Y_\kappa = \rho\beta^*\kappa\omega \text{ and } Y_\omega = \rho\beta\omega^2,$$

where  $\beta = F_1\beta_{i,1} + (1 - F_1)\beta_{i,2}$ . It should be noted that in the high-Reynolds number form of the  $\kappa - \omega$  model for the incompressible form,  $\beta^* = \beta_\infty^*$ .

The production terms of the turbulent kinetic energy and the specific dissipation rate are given as

$$G_\kappa = -\rho\overline{u'_i u'_j} \frac{\partial u_j}{\partial x_i} \text{ and } G_\omega = \alpha \frac{\rho}{\mu_t} G_\kappa,$$

where  $\alpha = \frac{\alpha_\infty}{\alpha^*} \left(\frac{\alpha_0^+ Re_t / R_\omega}{1 + Re_t / R_\omega}\right)$ ,  $R_\omega = 2.95$ ,  $\alpha_0 = \frac{1}{9}$  and  $\alpha_\infty$ . The value of  $\alpha$  is given by  $\alpha_\infty = F_1\alpha_{\infty,1} + (1 - F_1)\alpha_{\infty,2}$ , where  $\alpha_{\infty,1} = \frac{\beta_{i,1}}{\beta_\infty^*} - \frac{\kappa^2}{\sigma_{\omega,1}\sqrt{\beta_\infty^*}}$  and  $\alpha_{\infty,2} = \frac{\beta_{i,2}}{\beta_\infty^*} - \frac{\kappa^2}{\sigma_{\omega,2}\sqrt{\beta_\infty^*}}$ , where  $\kappa$  is 0.41. The cross-diffusion term is defined as

$$D_\omega = 2(1 - F_1)\rho\frac{1}{\omega\sigma_{\omega,2}}\frac{\partial\kappa}{\partial x_j}\frac{\partial\omega}{\partial x_j}.$$

The constants in the SST  $\kappa - \omega$  turbulence model are given as below:

$$\alpha_{\infty}^* = 1, \quad \sigma_{k,1} = 1.176, \quad \sigma_{k,2} = 1, \quad \sigma_{\omega,1} = 2, \quad \sigma_{\omega,2} = 1.168,$$

$$a_1 = 0.31, \quad \beta_{\infty}^* = 0.09, \quad \beta_{i,1} = 0.075, \quad \beta_{i,2} = 0.0828$$

The following form gives the energy equation

$$\frac{\partial}{\partial x_j}(\rho u_j h) = \frac{\partial}{\partial x_j} \left( k_{eff} \frac{\partial T}{\partial x_j} - \sum_i h_i \vec{J}_i \right),$$

where  $k_{eff}$  is the effective conductivity ( $k_{eff} = k + k_t$ , where  $k$  is the thermal conductivity and  $k_t$  is the turbulent thermal conductivity, given as  $\frac{c_p \mu_t}{Pr_t}$ , where  $Pr_t$  is the turbulent Prandtl number with value 0.85),  $\vec{J}_i$  is the diffusion flux of species  $i$ . For incompressible flows,  $h = \sum_i Y_i h_i$ .  $Y_i$  is the mass fraction of species  $i$  and  $h_i = \int_{T_{ref}}^T c_{p,i} dT$ , where  $T_{ref}$  is 298.15 K and  $c_{p,i}$  is the specific heat of species  $i$ .

The species transport equations are used when there is a need to model components in a mixture. In this study, CO<sub>2</sub> is a tracer gas that mixes with the air. The air used in this work consisted of four species: oxygen (O<sub>2</sub>), carbon dioxide (CO<sub>2</sub>), Nitrogen (N<sub>2</sub>) and water vapor (H<sub>2</sub>O). The conservation equation for the  $i$ th species transport is given as

$$\frac{\partial}{\partial x_j}(\rho u_j Y_i) = - \frac{\partial}{\partial x_j} \vec{J}_i,$$

where the mass diffusion term is given by  $\vec{J}_i = - \left( \rho D_{i,m} + \frac{\mu_t}{Sc_t} \right) \nabla Y_i$ , where  $Sc_t$  is the turbulent Schmidt number. Its value used in this work is 0.7. The  $D_{i,m}$  is the mass diffusion coefficient for  $i^{th}$  species in the mixture which is specified in this study as a constant value. An equation of this form is solved for  $N - 1$  species, where  $N$  is the total number of fluid phase chemical species. The  $N^{th}$  species mass fraction is determined as one minus the sum of the  $N - 1$  solved mass fractions.

## 5.4 Fluid Properties

In the above sections, various equations contain terms which need to be modeled. The fluid properties are described here. The density is modeled as the incompressible ideal gas law which is given as

$$\rho = \frac{p_{op}}{RT \sum_i \frac{Y_i}{M_{w,i}}},$$

where  $R$  is the universal gas constant,  $M_{w,i}$  is the molecular weight of species  $i$  and  $p_{op}$  is the operating pressure. The value of the specific heat capacity is defined as the mixing law which is given as  $c_p = \sum_i Y_i c_{p,i}$ , where  $c_{p,i}$  is the specific heat capacity of each of the species components modeled by the piecewise polynomial as a function of temperature.

The thermal conductivity is calculated using the mass-weighted-mixing-law which is computed based on a simple mass fraction average of the pure species conductivities as  $k = \sum_i Y_i k_i$ , where  $k_i$  is the thermal conductivities of species  $i$ . In a similar way, the viscosity is calculated using the mass-weighted-mixing-law which is computed based on a simple mass fraction average of the pure species viscosities as  $\mu = \sum_i Y_i \mu_i$ , where  $\mu_i$  is the viscosities of species  $i$ .

## 5.5 Boundary conditions

The boundary conditions for the simulations are based on the experimental setup that was described earlier. As described before in the section experimental measurements, the volumetric flow rate of the left inlet was  $0.148\text{m}^3/\text{s}$ , and the flow rate for the right inlet was  $0.152\text{m}^3/\text{s}$ . The air enters the room through multiple small inlet nozzles. Unfortunately, the airflow rate for the individual small inlets for both supply air inlets are not known. The air velocity is thus calculated based on the area of the nozzles. Thus, it is up to the user what type of air velocity is specified at each boundary. The only condition is that the total volumetric flow remains the same as in the experiments. The boundary conditions for the CFD simulations are prescribed as in Table 1.

TABLE 1. Boundary conditions for the CFD model.

Parts of the domain	Boundary conditions
Supply air inlets located in the hood	velocity inlet
Supply air outlets located in the hood	pressure-outlet
Door and windows	wall
Walls of the room, table and hood	wall
Heat source	velocity-inlet

As mentioned earlier in the CFD model, the air was modeled as a mixture of four species: oxygen, carbon dioxide, nitrogen and water vapor. The boundary conditions for the species components as used in the model are described in Table 2.

TABLE 2. Mole fractions of the species components in the model [%].

Source	O <sub>2</sub>	CO <sub>2</sub>	N <sub>2</sub>	H <sub>2</sub> O
Supply air inlets	20.9	0.043	79.057	0
Heat source	0	5, 10, 20	0	95, 90, 80

Table 2 describes that at the supply air inlets, air is modeled as consisting of only three species: oxygen, carbon dioxide and nitrogen. Thus, at the supply air inlets, the mass fraction of water vapor is defined as 0. At the heat source, different values of the mole fraction of carbon dioxide were defined in order to analyze the effect of carbon dioxide proportion on the overall distribution.

## 5.6 General guidelines for performing simulations

Simulation has emerged as a useful tool supporting design, working and analysis of ventilation systems. However, in some cases numerical predictions can even replace expensive experimental measurements. Thus, it is very important that the CFD simulations be conducted in a correct manner. Here, we address the mentioned guidelines in the REHVA book (Nielsen et al., 2007) to verify that the simulations in this work were conducted according to guidelines and using the standard practice. The quality of CFD simulations can depend on various factors such as proper mesh, models, boundary conditions and numerical procedures.



## 5.6.1 Computational mesh

One of the most important parts on which the solution of the flow equations depend is the selection of an appropriate mesh. The mesh represents how a computational domain is discretized into a finite number of control volumes. Obviously, the accuracy of the solution improves with the increase in the number of control volumes. Due to limited resources in computational speed and memory, a large number of control volumes is often not possible. At the very least, a fine enough mesh is required to ensure that the solution is accurate. For this kind of studies, using a small enough mesh size can be too computationally expensive.

Nielsen et al. (2007) in their book mentioned a formula (derived from the German guideline VDI 6019) that can be used as a rough guideline for the sufficient number of cells as  $44.4 \times 10^3 V^{0.38}$ , where  $V$  is the room volume. Using this formula for the simulated room gives the number of cells as about 190000. The number of cells used in this work, 3.7 million, is much higher than obtained from this formula. However, this formula does not address the cell distribution and the quality of the cells. Generally, higher resolution is needed in areas of relevant flow phenomena such as plumes above the heat source. The chosen meshing method for generating tetrahedral cells does take into account a greater number of cells at the boundary interface. Generally, in CFD studies, it is important to find a mesh-independent solution. By this, it means that the solution does not change significantly if a mesh is further refined. A study to find a mesh-independent solution was not conducted here.

## 5.6.2 Modeling

Fluid dynamics modeling is an important part of CFD analysis because it deals with the actual fluid flow equations that are solved numerically. In addition to the correct settings in the software and using the right numerical procedure, the prediction might still be different from the real situation. This is because the right equations were not selected for the modeling. One of the most important models in room airflow is the turbulence model. For turbulence modeling, several studies can be found in the literature that compare different turbulence models. The known deficiencies of the  $\kappa - \epsilon$  model can be partly overcome by the SST model which is a blend of the  $\kappa - \epsilon$  and the  $\kappa - \omega$  models. Thus, it is important to test the different turbulence models and compare them with experimental measurements

because there is no generally accepted turbulence model. In this study, a comparison of different turbulence models was made to check their feasibility.

### **5.6.3 Boundary conditions**

It is crucial in CFD simulations that proper and accurate boundary conditions are specified. Boundary conditions indicate how the user interprets the specific physical phenomena into a CFD code. Thus, detailed information about the boundary conditions is important in proper prediction of CFD results. If a physical phenomenon is not properly incorporated through the boundary conditions, then the corresponding analysis can give false results and its interpretation can be inaccurate.

Some errors can typically occur in specifying proper boundary conditions. Sometimes the exhaust outlet is specified through specific velocity rather than a pressure boundary. If a window is open, then assumption of appropriate values for the free flow boundary condition can be very difficult to estimate. Sometimes the values of airflow rate at inlets are not accurately specified which can cause some uncertainties in predicted results. For the modeled kitchen hood used in this work, the airflow is specified through multiple inlets. Unfortunately, the airflow rate for each inlet is not known in detail and this can influence the predicted results. This issue is addressed later in the discussion chapter.

### **5.6.4 Numerical procedure**

Discretization schemes also play an important role in the quality of the solution of flow equations. This type of discretization deals with how governing equations are discretized over the mesh. This step involves discretization of the differential equations around each mesh point (also called nodes) to obtain the algebraic equations for the flow variables that are solved using the iterative procedure. The numerical schemes developed earlier used the central difference formula for approximation of the governing equations. Even though the central differencing scheme is second order accurate, this scheme is unstable and results in oscillatory solutions. To remedy this, a denser mesh, i.e. a higher number of node points, is needed, which results in an increase in computational time.

Due to the unstable nature of the central differencing scheme and its inability to identify the flow direction, the upwind scheme (first order) was developed which was known to be unconditionally stable, but it led to false diffusion in the solution. To overcome this, the second-order upwind scheme was introduced which is more accurate and reduces the false diffusion in the solution. It is a highly recommended scheme in commercial codes and some journals prefer to at least use the second-order upwind scheme. Another higher order scheme such as QUICK is also recommended and works well for quadrilateral and hexahedral meshes.

Before performing a CFD simulation, the number of iterations and levels of residuals are defined. In the code ANSYS® Fluent, default values of convergence criteria are given. Normally, the required level of residuals to ensure that the convergence is achieved is always problem dependent. In order to be sure of the converged solution, lower values of residuals are needed. This can be accomplished by using a stricter criterion for the residuals' level. However, in some cases, the residuals do not converge below certain values, and hence continuing the solution procedure might be unnecessary.

## 5.7 Simulations

The CFD simulations in this work were conducted using ANSYS® Fluent. After the mesh was imported to ANSYS® Fluent, and after selecting the CFD models as described above, the general solution methods were set. The phase coupled SIMPLE algorithm was used for pressure-velocity coupling. Standards for pressure and second order upwind for momentum, turbulence equations, energy equations, and species variables equations were set as the discretization schemes. The limits for residuals for all the equations was set as  $1e-03$  and for the energy equation as  $1e-06$ . The under-relaxation factors were set to default.

To predict the effect of the airflow rates, different airflow rates were used in the CFD simulations, these being 150 l/s, 75 l/s, and 37.5 l/s, thus making a total of 4 cases. All the other settings as above remained the same. Only the amount of airflow rate has been changed. Experimental measurements with the lower airflow rates (150 l/s, 75 l/s and 37.5 l/s) were not performed. The comparison of CFD-predicted values and experimental measurements of lower airflow rates results is within the scope of future research work.

It is also interesting to perform numerical simulations with different rates of mole fractions for the tracer gas from the source to predict its mixing with the air. Thus, additional simulations were conducted for the different values of the mole fractions for the CO<sub>2</sub> and the H<sub>2</sub>O at the heat source as mentioned in Table 2.

# 6 RESULTS

## 6.1.1 Comparison of CFD results with experimental measurements

It is important to compare the results predicted using the CFD models with the experimental measurements. It should be noted that using CFD does not necessarily ensure that the results will be accurate. Thus, it is also of prime interest to focus on the aspect of how to verify, validate and report the CFD analysis (Chen and Srebric, 2002).

In this study, three different sensors were used to measure the concentrations of carbon dioxide in the room. Table 3 compares the measured and CFD-predicted values of carbon dioxide. Comparison was done for the case of inlet airflow rate of 300 l/s and for 0.2 mole fraction CO<sub>2</sub> at the source. In this section, the main aim was to compare the CO<sub>2</sub> concentration at sensor locations for different turbulence models with the measured values.

It can be clearly seen in Table 3 that the effect of turbulence models is significant. The predictions with all three of the  $\kappa - \epsilon$  models shows overestimation of the CO<sub>2</sub> concentrations. With the use of the  $\kappa - \omega$  models, the prediction is better. The SST  $\kappa - \omega$  model showed better prediction of values with experimental measurements in comparison to other turbulence models. However, it should be noted that none of the models matched the measured values very well. This could be due to several reasons, for example in the proper selection of CFD models or the way in which the solution of the flow equations was calculated. More experimental measurements must be performed for different airflow rates and then a suitable comparison for turbulence models can be made.

TABLE 3. Comparison of carbon dioxide concentrations using measured values and CFD values for different turbulence models.

	Sensor 1	Sensor 2	Sensor 3
Measured value	438 ppm	440 ppm	536 ppm
Standard $\kappa - \epsilon$ model	3514 ppm	5374 ppm	9765 ppm
Realizable $\kappa - \epsilon$ model	5585 ppm	6055 ppm	8187 ppm
RNG $\kappa - \epsilon$ model	6121 ppm	5029 ppm	8967 ppm
Standard $\kappa - \omega$ model	544 ppm	558 ppm	1284 ppm
SST $\kappa - \omega$ model	501 ppm	550 ppm	835 ppm

## 6.1.2 Carbon dioxide distributions

In this section, we compare the CFD results for  $\text{CO}_2$  distribution in the room for the different cases of supply inlet airflow rates. The selected turbulence model for the comparison was the SST  $\kappa - \omega$  model and the  $\text{CO}_2$  mole fraction at the heat source was 0.2. Figure 6.1 shows the carbon dioxide concentrations for different cases of airflow rates. It can be seen from Figure 6.1 that the airflow rate has a great effect on the carbon dioxide concentrations. For higher airflow rates, the carbon dioxide is accumulated above the heat source and below the hood. With a slightly lower airflow rate, a little dispersion of the tracer gas can be seen. For a still lower airflow rate, the dispersion is significant and the tracer gas travels upwards towards the outlet. With the lowest airflow rate, the maximum concentration of tracer gas can be observed near the outlet of the hood. This clearly shows that the airflow rate has a great effect on overall carbon dioxide distributions.

Thus, use of a higher airflow rate is unnecessary and, due to the design of the supply air inlets on the inner side of the hood, the airflow restricts the flow of carbon dioxide from traveling upwards. In a similar manner, Figure 6.2 shows the cross-sectional contours of carbon dioxide concentrations for all four cases on a different plane. The contours are taken on the YZ-plane at a distance of  $x=5.9$  m. The same conclusions can be made when a different cross-sectional view is seen, as in Figure 6.1. The airflow rates have a great effect on the carbon dioxide concentrations in the room.

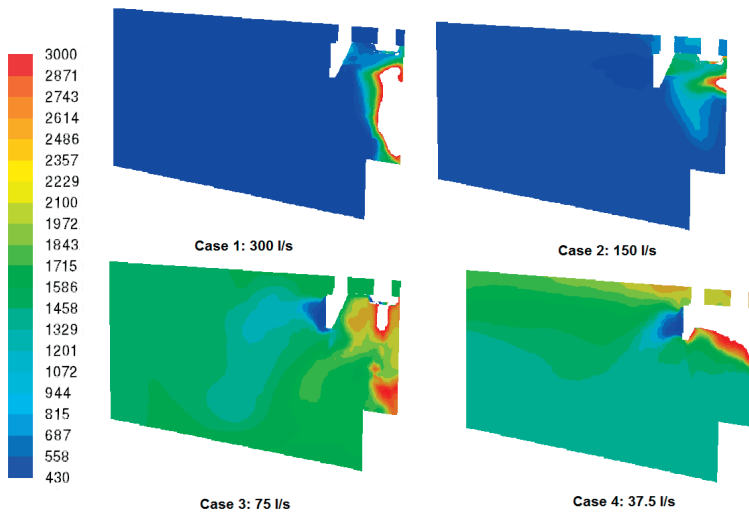

Figure 6.1. Contours of carbon dioxide concentrations (ppm) on the XY-plane at the distance of  $z = 1.02$  m.

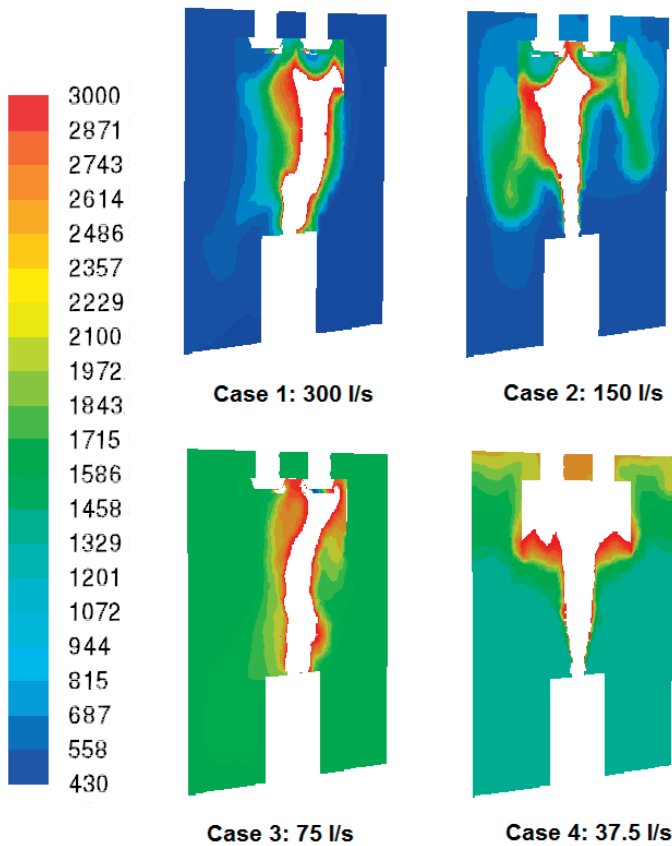

FIGURE 6.2 Contours of carbon dioxide concentrations (ppm) on the YZ-plane at a distance of  $x = 5.9$  m.

### 6.1.3 Comparison of different mole fractions of tracer gas

Additional simulations were also conducted for the different values of the mole fractions of the  $\text{CO}_2$  at the heat source as mentioned in Table 2. This was performed with the aim of comparing the carbon dioxide predictions for different concentrations at the source. The comparison was carried out for the case of 300 l/s airflow rate and using the SST  $\kappa - \omega$  model. Figure 6.3 shows the carbon dioxide distributions on two different planes for different values of  $\text{CO}_2$  mole fractions at the source. For the case of a 5% mole fraction, the concentration is dilute and much of the accumulation can be seen near the hood and the source. For the case of a 20% mole fraction, the maximum concentration is seen in between the hood and the source region. However, it

would be interesting to compare the same type of results for different airflow rates as well. These kinds of simulations can help to find a correlation between the airflow rates and distribution of the pollutants emitted from cooking activities.

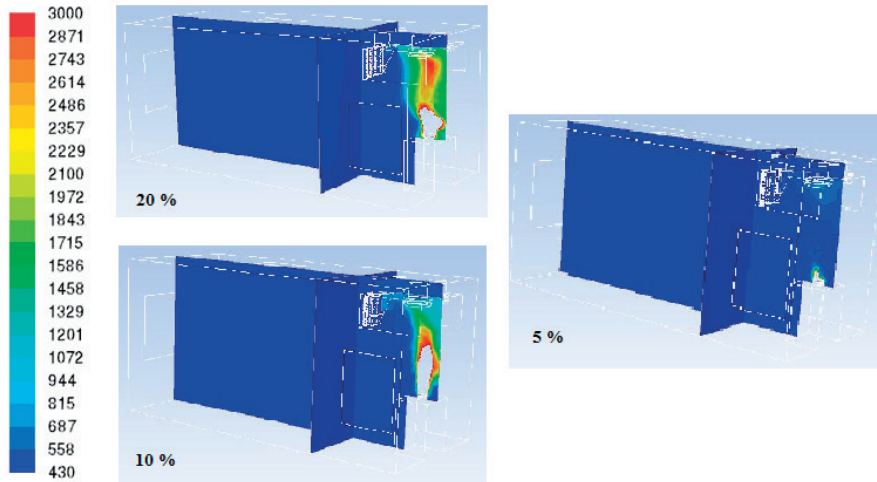

FIGURE 6.3. Contours of carbon dioxide concentrations (ppm) on two different planes using different values of CO<sub>2</sub> mole fractions at the source.



# 7 IMPROVING BUILDING ENERGY EFFICIENCY

## 7.1 Increasing energy efficiency and improving indoor air quality

As discussed in the previous chapters, ventilation is an important part of HVAC systems, which contribute to creating a better environment by providing thermal comfort and acceptable indoor air quality. However, ventilation also contributes to building energy consumption. Thus, in an effort to reduce energy consumption and increase energy efficiency, it is important to improve ventilation methods while maintaining indoor air quality. In this section, we address how the different ventilation strategies to increase energy efficiency and improve indoor air quality have been used and presented in the literature based on the work of Chenari et al. (2016). It should be noted that improvement of ventilation strategies to obtain energy savings must not compromise indoor air quality. In the end, the CFD-predicted results of this work, which support the findings of the literature, are explained .

An efficient ventilation system is one that is sufficient to maintain indoor air quality. The more ventilation, the better the quality of the indoor air. It would efficiently remove all the impurities from the stale indoor air by replacing it with fresh outdoor air. This idea came from the philosophy that it is the chemical properties of the indoor air that determine its quality, while physical properties of the air, such as temperature and humidity, influence thermal comfort (Fang et al., 1998). Thus, for improvements in both indoor air quality and thermal comfort, proper ventilation is very important.

In general, ventilation can be classified into two types: natural and mechanical. Natural ventilation is the type in which no energy or very little energy is used to keep the space ventilated. Mechanical ventilation consists of fans or air ducts that use electricity in order to provide the proper ventilation rate. The ideal situation would be natural ventilation as the sole, cheap source of air circulation. One of the problems with natural ventilation is the determination of the rate of incoming fresh air while simultaneously removing the impure air from the indoor environment. Due to expanding cities and changing lifestyles, there are more and more buildings being constructed, which ultimately reduces the

natural flow of air. Some studies dealing with how to evaluate the performance of natural ventilation can be found in the literature (Khan et al., 2008; Castillo and Huelsz, 2017; Jomehzadeh et al., 2017). Research dealing with CFD studies on natural ventilation can also be found in the literature (Allocca et al., 2003; Blocken, 2014; Tong et al., 2016). This clearly shows that there is an increasing trend in using CFD as a tool to analyze natural ventilation systems.

However, natural ventilation is not always possible or suitable. For example, natural ventilation is influenced by the effects of local climate, ventilation types, and the number of occupants. In places having a very hot summer climate or a very cold winter climate, natural ventilation is not sufficient. Nevertheless, there exist control systems in some conditions where natural ventilation is sufficient. Control systems that are available to occupants consist of doors, openable windows, curtains, fans, electric heaters, etc. which contribute to thermal comfort. These types of controls for natural ventilation can lead to energy savings because it is possible to predict when natural ventilation is sufficient (Raja et al., 1998).

In situations where there is a lack of natural ventilation due to weather conditions or its less possibilities for removing pollutants effectively, another alternative is the mechanical type of ventilation that leads to energy consumption. In mechanical ventilation, there is a constant minimum ventilation rate at which the air is allowed to enter the space to keep the space ventilated while maintaining indoor air quality and thermal comfort. Nowadays, buildings are mostly mechanically ventilated, which consumes a lot of energy. This problem has led engineers and researchers to develop a hybrid type of ventilation system that uses control systems that increase the influence of natural and mechanical systems, thus increasing energy efficiency. This is particularly useful when there is a lack of natural ventilation, and mechanical fans compensate the need for providing ventilation. Building elements such as doors and windows can be used when conditions are favorable, and then mechanical ventilation can be used when needed. Thus, it demands a controlled systems that is applied to hybrid ventilation in order to adjust between natural and mechanical ventilation.

One of the important factors in ventilation is the presence of the occupants. However, in the CFD studies conducted in this research, the effect of the presence of occupants was not considered, because there were no occupants present at the time of the experimental measurements. Nevertheless, this is very important as the systems that we are studying to improve air quality and thermal

comfort are always for the benefit of the occupants. This type of ventilation, in which the space is ventilated based on occupancy level, is known as demand controlled ventilation. It essentially uses the indoor air quality sensors and the outlet flow rate is adjusted to meet the demand. This is particularly useful in places where occupancy level varies frequently as in offices, restaurants, etc. Mysen et al. (2003) studied demand control ventilation for office cubicles and showed that this kind of ventilation control can reduce energy costs significantly. This type of ventilation is useful, because the ventilation is forced to meet the demand by maintaining acceptable indoor air quality.

This type of control system can be effective in terms of providing indoor air quality as well as saving cost because it only works when needed. However, an important parameter in this type of system is the determination of the correct ventilation airflow rate by which the indoor air quality is maintained. It is particularly important in kitchen environments to know how much of the ventilation airflow rate is actually needed to remove the pollutants generated from the cooking process. Of course, the level and type of pollutants generated during the cooking process varies significantly and thus it is a challenging task to determine suitable airflow rates. For general engineering practice, ventilation provides fresh air to the building's occupants and can present a huge energy load. Thus, ventilation systems are operated in such a way as to provide acceptable air quality through minimum rates. While doing this the known harmful concentrations are present in sufficiently small concentrations and statistically only 20% or less express dissatisfaction. Part of the study in this research is to check the effect of airflow rates.

Hesaraki et al. (2015) studied experimentally and analytically the effects of different ventilation airflow rates on the indoor air quality and energy savings for a single-family house located in Sweden. They concluded that with a lower ventilation airflow rate, an acceptable indoor air quality with a permissible carbon dioxide concentration is obtained when compared to the recommended ventilation rate by Swedish Building Standards. In a similar study using CFD analysis in a living room-kitchen environment, Kim and Hwang (2009) showed that out of the ventilated rates of 30, 60 and 120  $m^3/h$ , the ventilation rate of 60  $m^3/h$  satisfied all the criteria of indoor air quality and thermal comfort. For the case of 30  $m^3/h$ , the energy consumption was less but the indoor air quality was poor, and for the case of 120  $m^3/h$ , the indoor air quality was high but the energy consumption was higher. Thus, by lowering the ventilation airflow rate, it not only results in improving energy efficiency by reducing operational cost, but also provides acceptable indoor air quality.

In this study, CFD simulations were conducted for different ventilation rates. Consistently with the existing literature, the carbon dioxide concentrations predicted by the CFD simulations was dependent on the ventilation rates. With a higher ventilation rate, an unnecessary amount of energy is lost. Also, due to the design of the kitchen hood, the supply airflow inlets on the inner side of the hood restrict the path of the carbon dioxide from reaching the outlets and most of the carbon dioxide is concentrated near the walls between the heat source and the outlet of the hood. With lower values of ventilation rates, not only is there a reduction in energy costs, but carbon dioxide concentration is greater near the outlets.

## **7.2 Effect of the heat source on the hood**

Under normal kitchen conditions, cooking activities generate the heat in addition to the contaminants. In such conditions, the thermal plumes generated during the cooking process travel upwards due to the convective flow phenomena. Thus, the kitchen hood is normally placed above the stove so that the plumes from the cooking activities travel upwards and finally are released through the outlets of the hood. The design of the hood plays an important role in this process.

For the kitchen hood considered in this study, the airflow from the supply air inlets is entering the room in three directions. One of the directions is towards the room side, other one is in a downward direction, and the third one is towards the inner side of the hood. The air inlets facing the inner side of the hood have a very important role. The air from these inlets tends to mix with the tracer gas coming from the source. This is ideally the case where the cooking plumes tend to mix with the incoming air from the supply air inlets. The air velocity at these inlets greatly influences the flow dynamics and mixing with the tracer gas.

The velocity of the supply air inlets facing the downward direction is also important. The air flows downwards first and then moves towards the outlets of the hood. This leads to proper mixing of the air and the tracer gas. Such mixing dilutes the concentration of the tracer gas and also results in a better indoor environment for the occupants. However, it should be noted that the role of the ventilation is not only to dilute the contaminants, but also to efficiently remove them from the kitchen space.

The cooking plumes generally have a higher temperature than the air coming through the supply air inlets. However, the ventilation also provides extra momentum for the cooking plumes to flow upwards.

Thus, it is important that the excess heat is removed from the kitchen. If the air and tracer gas have mixed properly, then the temperature of the cooking plumes is reduced, which improves the thermal comfort.

## 8 DISCUSSION

As seen in the previous chapters, CFD numerically solves the equations of mass, Navier-Stokes, turbulence, energy and species transport. The solutions of these equations give fluid flow variables such as velocity, pressure, temperature, concentrations at all cell volumes. Solving these equations requires sufficient knowledge of fluid mechanics and a sophisticated CFD program. However, it should be noted that there can be many uncertainties present when performing CFD simulations. These generally vary according to the complexity of the problem at hand. In addition, selection of appropriate models, mesh sizes, solution methods and user experience are also important factors for successful CFD simulations.

Generally, the airflow in a ventilated room is turbulent in nature. Thus, one of the major factors in the study of ventilation systems using CFD is the choice of turbulence model. Turbulence is included in CFD models through additional terms, known as the Reynolds stresses, to which Reynolds averaging is applied. The Reynolds stresses must be modeled in order to close the Navier-Stokes equations resulting from the Reynolds averaging. One of the most common approach is to use the Boussinesq approximation that relates the Reynolds stresses to the eddy viscosity. Several models are available to determine the eddy viscosity and the choice is problem dependent. Poor choice of the eddy viscosity model can be one of the sources of uncertainty in CFD simulations.

Due to the uncertainty in CFD modelling, the CFD-predicted results are often validated with some kind of experimental measurement. Therefore, even though the use of CFD in the ventilation industry has been common for four decades, engineers and researchers are continuously working to develop more accurate CFD models. Accuracy can be improved by using more reliable CFD models. Accuracy can also be improved when using a finer mesh size in CFD simulations. The use of finer mesh sizes results in a large number of cell volumes, which increases the computational time. Thus, there is also a need to seek faster CFD models. It is true that the advancement in computational technology has enabled us to use parallel computing and high-speed computing facilities, but efforts are constantly being made to improve the numerical schemes used in CFD.

The geometry of the kitchen hood used in this work is complex. There are multiple inlets in the supply air inlets through which air enters the room. Figure 8.1 shows the multiple small inlets through which air enters the room.

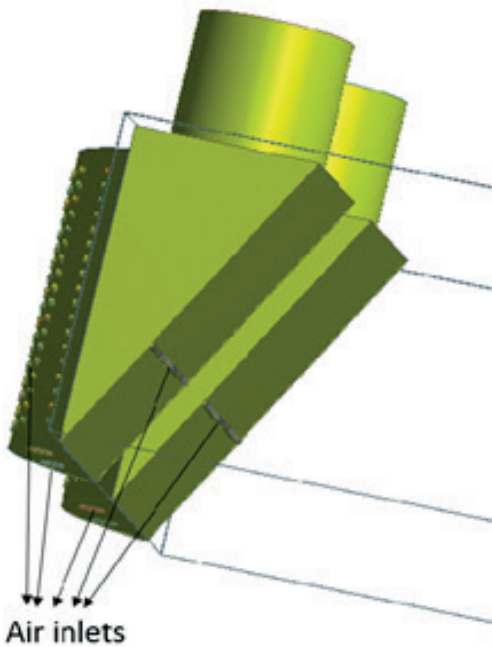

FIGURE 8.1. Multiple small inlets through which the air enters the room.

It can be seen in Figure 8.1 that there are two supply air inlets in the kitchen hood. The volumetric airflow rate for both of the supply air inlets can be individually measured. However, there are multiple small inlets in each of the supply air inlets for which the airflow rate cannot be measured. Moreover, multiple small inlets are facing in different directions. The number of inlets in different directions and their cross-sectional areas are not uniform. Thus, the volumetric airflow rate for different inlets is different. One way to estimate the correct airflow rate for each side inlet is to measure them individually. This might be convenient for getting an estimate, but it is difficult to measure. This can cause uncertainty and can affect the CFD predictions.

However, in a dynamic indoor environment, where indoor air is regularly polluted from the emission sources, the ventilation system must be cost effective and efficient at pollutant removal. For general engineering practice, ventilation provides fresh air to the building's occupants, but it can present a huge energy load. Thus, ventilation systems are operated in such a way as to provide acceptable air quality through minimum rates. It is true that higher ventilation rates can be costly, and lower ventilation rates can save energy. Nevertheless, insufficient ventilation leads to poor air quality and causes health issues.

Many researchers have reported controlling ventilation in terms of energy savings and occupant comfort. While it is important to consider the lower limit for energy requirements in order to provide a comfortable and healthy environment for people, it does not make sense to reduce energy consumption if it affects people's health. In a recent study, questions concerning the concept of green buildings and indoor air quality are discussed (Steinemann et al. 2017). On the other hand, if we concentrate only on better indoor air quality and neglect energy efficiency, then productivity is increased and health related problems are decreased. But the fundamental quandary then still remains: in the process of improving only indoor air quality, we are ultimately paying the price by spoiling the outdoor air quality. Therefore, developing methods to design and improve ventilation systems that can improve indoor climate and energy efficiency at the same time is challenging.



## 9 SUMMARY

This work presents CFD simulations of airflow in a ventilated room. The CFD simulations were performed to study the mixing of the air coming from the supply inlets with carbon dioxide, which was used as the tracer gas. Several CFD simulations using three-dimensional, steady state, incompressible Navier-Stokes equations with different turbulence models were performed. Energy transport and species transport equations were also solved together. The CFD results were compared with experimental measurements which were made using three sensors to estimate the concentrations of carbon dioxide at different locations in the room.

The effect of different airflow rates on carbon dioxide distribution was significant. With the higher airflow rates, most of the carbon dioxide was accumulated near the outlets and above the heat source. With the lower airflow rates, the carbon dioxide distribution was greater near the outlets.

Comparison between different turbulence models was also performed. Out of the used turbulence models, the  $\kappa - \omega$  models showed better results in comparison to the  $\kappa - \epsilon$  models. However, none of the models showed good agreement with the experimental measurements. It should also be noted that one set of measurement values is not enough, and there is a need to conduct more measurements to check the accuracy of the method.

Use of different values of CO<sub>2</sub> mole fractions at the source also revealed interesting results. With the lower values of CO<sub>2</sub> mole fractions, the overall concentration was dilute. With the higher values of CO<sub>2</sub> mole fractions, the concentration mainly accumulated between the hood and the source.

In terms of improving the energy efficiency of this kind of ventilation system, one of the solutions presented here is to reduce the ventilation airflow rate. There have been similar studies including analysis of improvement in energy efficiency by reducing the airflow rate. Even a CFD simulation showing effects of ventilation airflow rates has been studied and reached the same conclusion. However, this study was particularly conducted for kitchen spaces.

By lowering the ventilation airflow rate, it not only saves unnecessary energy

loss in comparison to higher ventilation airflow rates, but also better predicts the flow distribution by allowing proper mixing between the air and the tracer gas. It is still an open question whether there is any minimum ventilation rate that should be used to effectively remove the contaminants as well as maintain indoor air quality. This type of question can be answered by using control techniques in the form of sensors, so that ventilation is always available to maintain the indoor air quality. Demand-controlled ventilation systems will become much more efficient in the future, not just because energy consumption is reduced, but also by providing acceptable indoor air quality.

## REFERENCES

*Abanto, J. and Reggio, M. 2006.* Numerical investigation of the flow in a kitchen hood system. *Building and Environment* 41, 288–296.

*Allocca, C., Chen, Q. and Glicksman, L.R. 2003.* Design analysis of single-sided natural ventilation. *Energy and Buildings* 35, 785–795.

ANSYS, Inc. 2014. ANSYS® Fluent, Release 16.0, Theory Guide, ANSYS, Inc.

*Blocken, B. 2014.* 50 years of computational wind engineering: Past, present and future. *Journal of Wind Engineering and Industrial Aerodynamics* 129, 69–102.

*Bulińska, A., Popiołek, Z. and Buliński, Z. 2014.* Experimentally validated CFD analysis on sampling region determination of average indoor carbon dioxide concentration in occupied space. *Building and Environment* 72, 319–331.

*Cao, X., Dai, X. and Liu, J. 2016.* Building energy-consumption status worldwide and the state-of-the-art technologies for zero-energy buildings during the past decade. *Energy and Buildings* 128, 198–213.

*Castillo, J.A. and Huelsz, G. 2017.* A methodology to evaluate the indoor natural ventilation in hot climates: Heat balance index. *Building and Environment* 114, 366–373.

*Chen, J., Duffy, B., Fletcher, D.F., Haynes, D.F. and Nelson, P. 2001.* FTIR spectroscopy measurements and CFD simulations of the pollutants arising from unflued combustion in a room. *Building and Environment* 36, 597–603.

*Chen, Q. 2009.* Ventilation performance prediction for buildings: A method overview and recent applications. *Building and Environment* 44, 848–858.

*Chen, Q., Lee, K., Mazumdar, S., Poussou, S., Wang, L., Wang, M. and Zhang, Z. 2010.* Ventilation performance prediction for buildings: Model assessment. *Building and Environment* 45, 295–303.

*Chen, Q. and Srebric, J. 2002.* A procedure for verification, validation, and reporting of indoor environment CFD analyses. *HVAC&R Research* 8, 201–216.

*Chenari, B., Carrilho, J.D. and da Silva, M.G. 2016.* Towards sustainable, energy-efficient and healthy ventilation strategies in buildings: A review. *Renewable and Sustainable Energy Reviews* 59, 1426–1447.

*Chiang, C.-M., Lai, C.-M., Chou, P.-O. and Li, Y.-Y. 2000.* The influence of an architectural design alternative (transoms) on indoor air environment in conventional kitchens in Taiwan. *Building and Environment* 35, 579–585.

*Chow, W.K. 1996.* Application of computational fluid dynamics in building services engineering. *Building and Environment* 31, 425–436.

COM (2016) 765 final 2016. [https://ec.europa.eu/energy/sites/ener/files/documents/1\\_en\\_act\\_part1\\_v10.pdf](https://ec.europa.eu/energy/sites/ener/files/documents/1_en_act_part1_v10.pdf).

*Dutt, D., Srinivasa, D.K., Rotti, S.B., Sahai, A. and Konar, D. 1996.* Effect of indoor air pollution on the respiratory system of women using different fuels for cooking in an urban slum of Pondicherry. *The National Medical Journal of India* 9, 113–117.

European commission Ecodeign 2017. [http://ec.europa.eu/growth/industry/sustainability/ecodesign\\_fi](http://ec.europa.eu/growth/industry/sustainability/ecodesign_fi). Updated 11.5.2017. Read 11.5.2017.

European Commission Energy 2017. <https://ec.europa.eu/energy/en/topics/energy-efficiency/buildings>. Updated 11.5.2017. Read 11.5.2017.

*Fang, L., Clausen, G. and Fanger, P.O. 1998.* Impact of temperature and humidity on the perception of indoor air quality. *Indoor Air* 8, 80–90.

*Fletcher, C.A.J., Mayer, I.F., Eghlimi, A. and Wee, K.H.A. 2001.* CFD as a building services engineering tool. *International Journal on Architectural Science* 2, 67–82.

*Gao, J., Cao, C, Xiao, Q., Xu, B. Zhou, X. and Zhang, X. 2013.* Determination of dynamic intake fraction of cooking-generated particles in the kitchen. *Building and Environment* 65, 146–153.

*Gilani, S., Montazeri, H. and Blocken, B. 2016.* CFD simulation of stratified indoor environment in displacement ventilation: Validation and sensitivity analysis. *Building and Environment* 95, 299–313.

*Harish, V.S.K.V. and Kumar, A. 2016.* A review on modeling and simulation of building energy systems. *Renewable and Sustainable Energy Reviews* 56, 1272–1292.

*Hesaraki, A., Myrhen, J.A. and Holmberg, S. 2015.* Influence of different ventilation levels on indoor air quality and energy savings: A case study of a single-family house. *Sustainable Cities and Society* 19, 165–172.

*Jomehzadeh, F, Nejat, P, Calautit, J.K., Yusof, M.B.M., Zaki, S.A., Hughes, B.R. and Yazid, M.N.A.W.M. 2017.* A review on windcatcher for passive cooling and natural ventilation in buildings, Part 1: Indoor air quality and thermal comfort assessment. *Renewable and Sustainable Energy Reviews* 70, 736–756.

*Jones, A.P. 1999.* Indoor air quality and health. *Atmospheric Environment* 33, 4535–4564.

*Khan, J.A., Feigley, C.E., Lee, E., Ahmed, M.R. and Tamanna, S. 2006.* Effects of inlet and exhaust locations and emitted gas density on indoor air contaminant concentrations. *Building and Environment* 41, 851–863.

*Khan, N., Su, Y. and Riffat, S.B. 2008.* A review on wind driven ventilation techniques. *Energy and Buildings* 40, 1586–604.

*Kim, M.-H. and Hwang, J.-H. 2009.* Performance prediction of a hybrid ventilation system in an apartment house. *Energy and Buildings* 41, 579–596.

*Kosonen, R. 2006.* The effect of thermal plumes on the performance of ventilated ceilings in commercial kitchens. PhD Thesis. Helsinki University of Technology.

*Kuznik, F, Rusaouën, G. and Brau, J. 2007.* Experimental and numerical study of a full scale ventilated enclosure: Comparison of four two equations closure turbulence models. *Building and Environment* 42, 1043–1053.

*Lai, A.C.K. and Ho, Y.W. 2008.* Spatial concentration variation of cooking-emitted particles in a residential kitchen. *Building and Environment* 43, 871–876.

*Lee, E., Feigley, C.E. and Khan, J. 2002.* An investigation of air inlet velocity in simulating the dispersion of indoor contaminants via computational fluid dynamics. *The Annals of Occupational Hygiene* 46, 701–712.

*Li, Y. and Nielsen, P.V. 2011.* Commemorating 20 years of indoor air: CFD and ventilation research. *Indoor Air* 21, 442–453.

*Lim, K. and Lee, C. 2008.* A numerical study on the characteristics of flow field, temperature and concentration distribution according to changing the shape of separation plate of kitchen hood system. *Energy and Buildings* 40, 175–184.

*Metayer, C., Wang, Z., Kleinerman, R.A., Wang, L., Brenner, A.V., Cui, H., Cao, J. and Lubin, J.H. 2002.* Cooking oil fumes and risk of lung cancer in women in rural Gansu, China. *Lung Cancer* 35, 111–117.

*Ministry of the Environment 2017.* [http://www.ym.fi/fi-FI/Maankaytto\\_ja\\_rakentaminen/Lainsaadanto\\_ja\\_ohjeet/Rakentamismaarayskokoelma/Valmisteilla\\_olevat](http://www.ym.fi/fi-FI/Maankaytto_ja_rakentaminen/Lainsaadanto_ja_ohjeet/Rakentamismaarayskokoelma/Valmisteilla_olevat). Updated 10.1.2017. Read 11.5.2017.

*Motiva 2016.* [https://www.motiva.fi/koti\\_ja\\_asuminen/kestava\\_kuluttaminen\\_ja\\_hankinnat/energiamerkinta/liesituulettimet](https://www.motiva.fi/koti_ja_asuminen/kestava_kuluttaminen_ja_hankinnat/energiamerkinta/liesituulettimet). Updated 21.11.2016. Read 11.5.2017.

*Mysen, M. Rydock, J.P. and Tjelflaat, P.O. 2003.* Demand controlled ventilation for office cubicles—can it be profitable? *Energy and Buildings* 35, 657–662.

*Nielsen, P.V. 2004.* Computational fluid dynamics and room air movement. *Indoor Air* 14 (Supplement 7), 134–143.

*Nielsen, P.V. 2015.* Fifty years of CFD for room air distribution. *Building and Environment* 91, 78–90.

*Nielsen, P.V. (Ed.), Allard, F., Awbi, H.B., Davidson, L. and Schälin, A. 2007.* Computational Fluid Dynamics in Ventilation Design. *Rehva Guidebook* No. 10, Forssa.

*Ning, M., Mengjie, S., Mingyin, C., Dongmei, P. and Shiming, D. 2016.* Computational fluid dynamics (CFD) modelling of air flow field, mean age of air and CO<sub>2</sub> distributions inside a bedroom with different heights of conditioned air supply outlet. *Applied Energy* 164, 906–915.

*Norton, T. and Sun, D.-W. 2006.* Computational fluid dynamics (CFD) – an effective and efficient design and analysis tool for the food industry: A review. *Trends in Food Science & Technology* 17, 600–620.

*Peng, L., Nielsen, P.V., Wang, X., Sadrizadeh, S., Liu, L. and Li, Y. 2016.* Possible user-dependent CFD predictions of transitional flow in building ventilation. *Building and Environment* 99, 130–141.

*Pérez-Lombard, L., Ortiz, J. and Pout, C. 2008.* A review on buildings energy consumption information. *Energy and Buildings* 40, 394–398.

*Posner, J.D., Buchanan, C.R. and Dunn-Rankin, D. 2003.* Measurement and prediction of indoor air flow in a model room. *Energy and Buildings* 35, 515–526.

*Raja, I.A., Nicol, J.F. and McCartney, K.J. 1998.* Natural ventilated buildings: Use of controls for changing indoor climate. *Renewable Energy* 15, 391–394.

*Rojas, G., Pfluger, R. and Feist, W. 2015.* Cascade ventilation—Air exchange efficiency in living rooms without separate supply air. *Energy and Buildings* 100, 27–33.

*Saha, S., Guha, A. and Roy, S. 2012.* Experimental and computational investigation of indoor air quality inside several community kitchens in a large campus. *Building and Environment* 52, 177–190.

*Shen, X., Zhang, G. and Bjerg, B. 2012.* Comparison of different methods for estimating ventilation rates through wind driven ventilated buildings. *Energy and Buildings* 54, 297–306.

*Stamou, A. and Katsiris, I. 2006.* Verification of a CFD model for indoor airflow and heat transfer. *Building and Environment* 41, 1171–1181.

*Steinemann, A., Wargocki, P. and Rismanchi, B. 2017.* Ten questions concerning green buildings and indoor air quality. *Building and Environment* 112, 351–358.

*Sundell, J. 2004.* On the history of indoor air quality and health. *Indoor Air* 14 (Supplement 7), 51–58.

*Sørensen, D.N. and Nielsen, P.V. 2003.* Quality control of computational fluid dynamics in indoor environments. *Indoor Air* 13, 2–17.

*Tham, K.W. 2016.* Indoor air quality and its effects on humans – A review of challenges and developments in the last 30 years. *Energy and Buildings* 130, 637–650.

*Tong, Z., Chen, Y. and Malkawi, A. 2016.* Defining the influence region in neighborhood-scale CFD simulations for natural ventilation design. *Applied Energy* 182, 625–633.

*Wang, L. and Chen, Q. 2008.* Evaluation of some assumptions used in multizone airflow network models. *Building and Environment* 43, 1671–1677.

*Yu, K.-P., Yang, K.R., Chen, Y.C., Gong, J.Y., Chen, Y.P., Shih, H.-C. and Lung, S.-C.C. 2015.* Indoor air pollution from gas cooking in five Taiwanese families. *Building and Environment* 93, 258–266.

*Zhai, Z. 2006.* Application of computational fluid dynamics in building design: aspects and trends. *Indoor and Built Environment* 15, 305–313.

*Zhai, Z., Zhang, Z., Zhang, W. and Chen, Q. 2007.* Evaluation of various turbulence models in predicting airflow and turbulence in enclosed environments by CFD: Part 1–Summary of prevalent turbulence models. *HVAC&R Research* 13, 853–870.

*Zhou, B., Chen, F., Dong, Z. and Nielsen, P.V. 2016.* Study on pollution control in residential kitchen based on the push-pull ventilation system. *Building and Environment* 107, 99–112.

*Versteeg, H.K. and Malalasekera, W. 1995.* An introduction to Computational Fluid Dynamics: The Finite Volume Method. Harlow: Longman.



- 1 *Srujal Shah - Kari Dufva: CFD modeling of airflow in a kitchen environment. Towards improving energy efficiency in buildings. 2017.*



Kaakkois-Suomen  
ammattikorkeakoulu