

Uwe Eguenu Ola

PLATE HEAT EXCHANGER DESIGN METHODOLOGY

Bachelor's thesis

**CENTRAL OSTROBOTHNIA UNIVERSITY OF APPLIED
SCIENCES**

Degree Programme in Chemistry and Technology

February 2011

ACKNOWLEDGEMENT

I want to use this opportunity to thank the almighty God for His guidance, which has led me to the successful completion of my studies.

I would like to express my sincere thanks to my supervisor Kaj Jansson and lecturers that taught me and have contributed immensely to the successful completion of my studies.

I would like to express my gratitude towards my parents and members of my family for their kind co-operation and encouragement, which help me greatly in completing my studies.

My warmest thanks and appreciation goes as well to my friends and colleagues who have willingly supported me with their abilities.

Thesis Abstract

Department Chemistry and Technology, Kokkola	Date 21 January 2011	Author Uwe Eguenu Ola
Degree programme Degree Programme in Chemistry and Technology		
Name of thesis Plate heat exchanger design methodology		
Instructor Kaj Jansson	Pages 48 + 1 Appendix	
Supervisor Kaj Jansson		
<p>This research gives an overview of the types of plate heat exchangers used in the manufacturing and process industry. The main purpose of this study was to achieve an efficient method used in the construction and design of plate heat exchangers, which is capable of transferring heat from the hot fluid stream to the cold fluid stream by effectively achieving the required heat transfer area in the process.</p> <p>To achieve this several iteration must be made before a final acceptable assembly drawing and procedure is accepted, since the construction of a plate heat exchanger depends on many factors such as the type of frame, plate dimension, gaskets, flow, pressure drop, plate arrangement and piping arrangement. The system of approach presented in this study can be used as a general guide during construction and design of plate heat exchangers.</p> <p>This research employs the use of simulation and iteration methods to compare the accuracy of the result obtained during the design of the equipment, which takes into consideration the thermal hydraulic parameters of the fluid streams.</p>		

Key words

plate heat exchanger, design method, number of plate , heat transfer coefficient, Fouling factor

TABLE OF CONTENTS

LIST OF GRAPHS	V
LIST OF TABLES	VI
LIST OF SYMBOLS	VII
1 INTRODUCTION	1
2 BACKGROUND	2
2.1 Basic features of plate heat exchangers	2
2.2 Historical background	3
2.3 Working principle	3
3 CLASSIFICATION OF PLATE HEAT EXCHANGERS	5
3.1 Gasketed plated heat exchangers	5
3.2 Welded plate heat exchangers	6
3.3 Spiral plate heat exchangers	7
3.4 Brazed plate heat exchangers	8
3.5 Fusion-bonded plate heat exchanger	9
3.6 Lamella heat exchanger	10
4 DESIGN AND OPERATION OF PLATE HEAT EXCHANGERS	12
4.1 Material used for plate design	12
4.2 Material used for gasket design	15
4.3 Operation and selection	16
4.4 Advantages of plate heat exchangers	19
4.5 Limitations of plate heat exchangers	19
4.6 Industrial applications	20
5 BASIC DESIGN METHODOLOGY	21
5.1 Thermal hydraulic design	23
5.2 Flow arrangement of the fluid streams	23

5.3 Temperature distribution	25
5.4 Design equations and energy balances	27
5.5 Design method	31
5.6 Case study of design methodology	33
5.6.1 Theoretical solution	37
6 RESULTS AND DISCUSSIONS	44
7 CONCLUSIONS	46
REFERENCES	47

LIST OF GRAPHS

GRAPH 1. Working principle of a plate heat exchanger

GRAPH 2. Gasketed plate heat exchanger

GRAPH 3. Plate section of a welded plate heat exchanger

GRAPH 4. Welded plate heat exchanger

GRAPH 5. Spiral plate heat exchanger

GRAPH 6. Brazed plate heat exchanger

GRAPH 7. Fusion bonded plate heat exchanger

GRAPH 8. Cross section of the lamella heat exchanger showing the lamellas

GRAPH 9. Gasket setting on a plate heat exchanger

GRAPH 10. A typical industrial application of plate heat exchangers in heat and power generation plant.

GRAPH 11. Overview of plate heat exchanger design methodology

GRAPH 12. Parallel flow arrangement in a two fluid plate heat exchanger

GRAPH 13. Counter flow arrangement in a two fluid plate heat exchanger

GRAPH 14. Typical multi pass arrangement in a two fluid plate heat exchanger

GRAPH 15. Temperature distribution in a parallel flow arrangement

GRAPH 16. Temperature distribution in counter flow arrangement

GRAPH 17. Diagrammatic design methodology

LIST OF TABLES

TABLE 1. Plate material selection

TABLE 2. Operating range of gasketed plate heat exchanger

TABLE 3. Properties of the fluid streams

TABLE 4. Constructional data for proposed plate heat exchanger

TABLE 5. Design simulation result summary

TABLE 6. Result summary of the design method that gives a key comparison between the two methodologies employed.

LIST OF SYMBOLS

A_a	actual heat transfer area of the plate (m^2)
A_{ch}	flow area of a channel (m^2)
A_e	effective heat transfer area (m^2)
A_n	nominal heat transfer area (m^2)
A_{pr}	projected plate area (m^2)
A_s	single plate heat transfer area (m^2)
A_T	total effective area of plate (m^2)
b	channel spacing or gap between plates (m)
C_p	specific heat capacity ($J/kg \cdot ^\circ C$)
D_h	hydraulic diameter or channel equivalent diameter (mm)
D_p	port diameter (mm)
F	correction factor
f	fanning friction factor
G	mass velocity or mass flux ($kg/m^2 \cdot s$)
h	convective heat transfer coefficient ($W/m^2 \cdot ^\circ C$)
K_p	constant in Equation (22)
k	thermal conductivity ($W/m \cdot ^\circ C$)
L_c	compressed plate pack length (mm)
L_h	horizontal port width (m)
L_v	vertical port length (m)
L_w	plate width (m)
L_{eff}	effective flow length between inlet and outlet port (m)
LMTD	log mean temperature difference (K)
\dot{m}	mass flow rate (kg/s)
m	constant in equation (22)
N_{cp}	number of flow channel per pass
N_e	number of effective heat transfer plates
N_p	number of passes
N_t	Total number of plates
Nu	Nusselt number, dimensionless
NTU	number of transfer units
P	pressure (Pa)

p	plate pitch (mm)
Pr	Prandtl number, dimensionless
Q	heat transfer rate (W)
Re	Reynolds number, dimensionless
R_f	fouling resistance on plate surface ($m^2.K/W$)
T	temperature (K)
u_{ch}	flow channel velocity (m/s)
U	overall heat transfer coefficient ($W/m^2.K$)
ΔP_c	channel pressure drop (Pa)
ΔP_p	port pressure drop (Pa)
ΔP_t	total pressure drop (Pa)
ΔT	change in temperature (K)
δ_p	thickness of the plate (m)
μ	dynamic viscosity (kg/m^3)
ρ	density (kg/m^3)

1 INTRODUCTION

Heat transfer in the simplest term is the movement of heat from one place to another and the process of transferring heat between two or more fluid streams at different temperatures is achieved by specialized designed equipment known as heat exchangers. There are several types of heat exchangers, which are generally classified based on their heat transfer mechanism, size and shape.

This work is about plate heat exchangers, which is frequently used in the manufacturing and process industries. The main purpose of this study is to achieve an efficient method used in the construction and installation of plate heat exchangers that will take into consideration all parameters related to the construction and design of plate heat exchangers. This will give a general idea of the problem field associated with the design and application. The thermal-hydraulic design of the plate heat exchanger and other physical properties is mentioned in this study.

In the study, a design method is presented which calculates several parameters such as the pressure drop, total effective heat transfer area of plate, Reynolds, Nusselt numbers and the optimum number of plates in plate heat exchangers operating with a given fluid stream and different operating conditions.

To analyse the effects of the hot/cold fluid streams, several iterations are made with the flow rates, temperatures, and physical properties. The plate material will be changed and the hot fluid will be kept constant in order to get a proper comparison between the different types of fluid stream used on the given plate material to obtain the combination that will yield the efficient thermal hydraulic design of plate heat exchangers. The design process is done on parallel and counter-current flow arrangements whereby the log mean temperature difference is calculated for the different arrangements where possible.

Furthermore, the data obtained by using the simulation and iteration methods are compared and the accuracy of the result is determined, which takes into consideration the thermal hydraulic parameters of the fluid streams. The simulated design data is used to compare the values from literature.

2 BACKGROUND

2.1 Basic features of plate heat exchangers

Plate Heat exchangers are heat transfer devices that are employed to transfer heat between diverse fluid streams at different temperatures. Heat exchangers are usually classified as direct contact or indirect contact heat exchangers. The direct contact heat exchanger there is no intervening surface between fluids and due to this fact, they could achieve closer approach temperatures, while the indirect contact heat exchanger is a device that employs the transfer of heat between two fluids or between a surface and a fluid.

The plate heat exchanger is a perfect example of indirect contact heat exchanger and it is composed of a series of corrugated plates, which forms the core that enhances and conduct heat transfer through the plates. The thermal plates consist of gaskets confined in a formed groove around the perimeter of the plate that contains the fluid between the plates. (API 2010)

Plate heat exchangers have several advantages because of their respective design methodology, which is relatively inexpensive and easy to dismantle during maintenance. Furthermore, plate heat exchangers can accommodate a wide range of fluids and the specialized surface area enhancement due to the many corrugations of the plate implies that a great deal of surface can be packed into a small volume which makes the design compact. This implies that plate heat exchangers are perfect example of compact heat exchangers because of its efficient heat transfer surface having a surface area density above about $700\text{m}^2/\text{m}^3$. Other example of indirect contact exchanger is the shell and tube heat exchangers that have a large hydraulic diameter with small surface area to volume ratios.

Due to the drawbacks of other designs of indirect contact heat exchanger led to the innovative development of different types of more efficient heat exchangers which

usually have a high surface area to volume ratio that enhance the thermal hydraulic performance and energy efficiency.

2.2 Historical background

The first known plate heat exchanger was invented by Dr Richard Seligman of the Aluminium plant and vessel company, the earliest development of plate heat exchangers was for milk pasteurization. The application of heat to the raw milk with the aid of the plate heat exchanger to a certain temperature that is maintained for a short time and then it is cooled immediately. The objective was to pasteurize the milk to slow down microbial growth, which further limits the spread of milk borne infectious diseases. Pasteurisation requires very efficient heat transfer equipment like the plate heat exchanger, which is very easy to dismantle for inspection and cleaning during usage. This further led to the innovative invention of the plate heat exchangers in the 1920s that revolutionised the indirect heating and cooling of fluids in the manufacturing world today. (APV 2010)

The introduction of the world's first commercial plate heat exchanger was in 1923 by the inventor Dr Richard Seligman the founder of the aluminium plant and vessel company which is nowadays known as APV. This plate heat exchanger was manufactured on a gun casted metal plate that was enclosed in a frame that sets the standard for today's plate heat exchanger design and construction (APV 2010).

2.3 Working principle

Plate heat exchangers works with the same basic working principle of any other heat exchanger in which there is transfer of heat between two or more fluid streams through a separating wall. In the case of a plate heat exchanger, heat transfer occurs through the separating wall or plate with no intermixing of the liquids flowing through the plates or leakages to the surrounding because of the aid of gaskets placed around the edges of the plates, which seals each unit. Furthermore, the corrugated nature of the plates

provides a suitable passage of fluids flow between plates and thus there is maximum heat transfer efficiency. (Alfa Laval 2010)

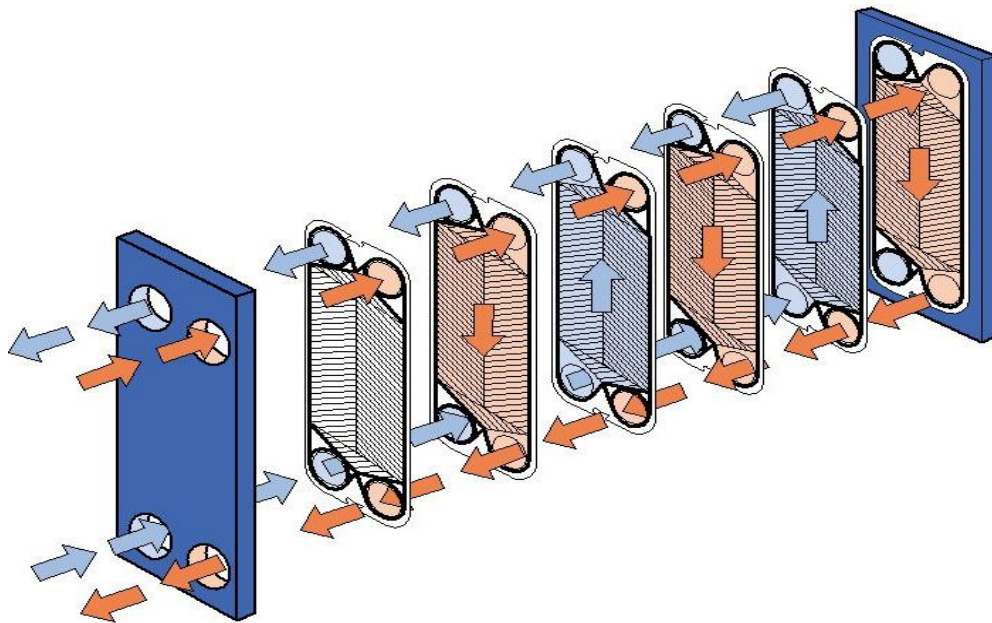

GRAPH 1. Working principle of a Plate heat exchanger (Alfa Laval 2010)

Graph 1 above shows the flow principle of plate heat exchangers whereby the hot and cold fluid streams flows in different pathways in opposite direction without intermixing with each other. This illustration gives a flow arrangement whereby the hot and cold stream flows entering and leaving the plate heat exchanger through the portholes on the plate where heat transfer takes place between the hot fluid and the cold fluid stream. (Bejan & Kraus 2003.)

3 CLASSIFICATION OF PLATE HEAT EXCHANGERS

Plate heat exchangers can be classified based on their structure and specifically how the plates are attached together. This includes gasketed, welded, spiral plate, brazed, lamella, and fusion bonded plate heat exchangers respectively.

3.1 Gasketed plate heat exchangers

Gasketed plate heat exchangers are made up of a series of rectangular corrugated metal or alloy plates, which the edges are specifically sealed by gaskets and held firmly together in a frame as shown in graph 2 below. The design is well tailored in such a way that the frame has a fixed end cover that is fitted with connecting ports and a movable end cover that can be a pressure plate or a tailpiece. Plates are usually suspended in the frame from an upper carrying screw bar that is securely guided by a bottom-carrying bar, which supports and enables proper alignment of the entire equipment. (Shah & Sekulic 2003.)

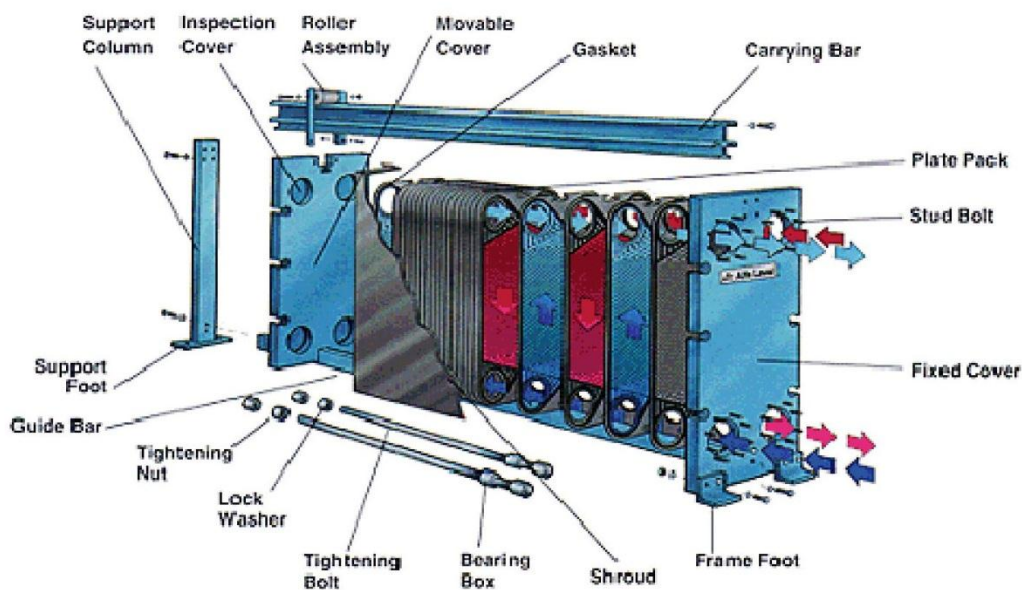

GRAPH 2. Gasketed plate heat exchanger (Alfa Laval 2010)

Furthermore, due to the design of the gasketed plate heat exchanger which has several moveable parts makes inspection and cleaning of the plates easily accessible, which can be done as frequent as possible were necessary to optimize the functionality of the equipment.

The gaskets are well interlocked and embedded in the plates to prevent blowout at a high-pressure difference because the design of the gaskets shows that it can compress about 25 % of thickness in a bolted plate heat exchanger which further provides a leak tight joint without any distortion of the thin plates. Ports on each corners of the plate serves as headers of which the gasket direct the fluid flow while also serving as the primary seal of the system. (Shah & Sekulic 2003.)

3.2 Welded plate heat exchangers

Welded plate heat exchangers are constructed by welding the heat transfer plates on both the hot and cold fluid streams of the equipment, which reduces the cost of welding the entire plate significantly. The welding is usually done by laser welding whereby in between the plates is welded in the location where the gaskets are usually placed in the case of a gasketed plate heat exchanger and this welding is done around the complete circumference of the plate. (API 2010.)

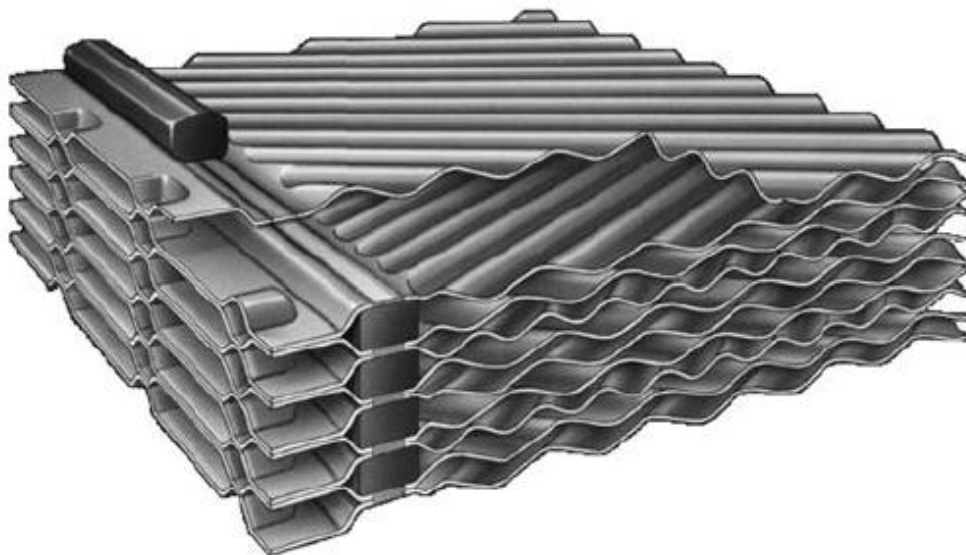

GRAPH 3. Plate section of a welded plate heat exchanger (Alfa Laval 2010)



GRAPH 4. Welded plate heat exchanger (WCR 2010)

The design of the welded plate heat exchanger favours the use of corrosive fluid streams as either the hot or the cold fluid media since the corrosive fluid cannot wear and tear the welded corrugated metal plates used as the heat transfer media in this case. Welded plate heat exchangers are compact heat exchangers that are very durable and gasket free, therefore they are capable in operating at very high temperature and pressure conditions. The materials used in the fabrication of the plates are stainless steel, hastelloy, nickel based alloys, titanium and copper. (Shah & Sekulic 2003.)

3.3 Spiral plate heat exchanger

The spiral plate heat exchanger consist of two long strips of metal or alloy sheet that is usually welded with studs for plate spacing, which is wrapped helically to form a pair of spiral channels for two fluid streams. The materials used in the design are carbon steel, stainless, titanium, hastelloy, incoloy and high nickel alloys.



GRAPH 5. Spiral plate heat exchanger (National Heat Exchange Corporation 2010)

The spiral plate heat exchanger is widely employed when using viscous, slurry and fouling fluid stream because the two curved metal or spiral plates creates an extremely high turbulent flow in a counter current pattern. The fouling rate of spiral plate heat exchanger is very low compared to the other types of plate heat exchangers used in the manufacturing industries. The maximum operating pressure is 0.6 to 2.5MPa and temperature is limited to 500°C but in some cases, they are designed to operate with a temperature of 200°C. (Process solutions 2010.)

3.4 Brazed plate heat exchangers

Brazed plate heat exchanger is a rugged design of plate heat exchangers, which consist of corrugated plates vacuum brazed together at a very high temperature. The design creates a compact and leak tight equipment, which does not employ the use of gaskets. This design is very simple because it is usually smaller than the other types of plate heat exchangers, which implies that the smaller size reduces the material content and making it one of the most economic heat transfer equipment. (Process solutions 2010)

The very high compact design of the brazed plate heat exchanger makes it extremely efficient, easy to install and manage compared to the other types of heat exchangers. The brazed plate heat exchanger has a very high corrosion resistance and can operate with a

temperature between -195°C to 400°C with an operating pressure of almost 50 bar can be achieved. (API 2010.)



GRAPH 6. Brazed plate heat exchanger (GEA PHE systems 2010)

Brazed plate heat exchangers are usually cleaned chemically due to their compact design, which makes it difficult to disassemble the plates for inspection and cleaning. They are widely employed in district water heating systems, power plants equipment installations like chillers and compressors (Alfa Laval 2010).

3.5 Fusion bonded plate heat exchangers

Fusion bonded plate heat exchanger is one of the most recent technological innovations exploited by Alfa Laval, which comprises of 100% corrugated stainless steel plates and pressure plate. The heat transfer plates are bonded together in a frame by using the Alfa fusion technology, which is a unique method of bonding steel components by the application of transient liquid phase bonding to firmly join the steel components together.

This innovation in the design of plate heat exchangers is only available from Alfa Laval and this particular design is very hygienic which makes it work efficiently when used for

district heating installations within areas of corrosive waters because it has very high corrosive and temperature resistance. Graph 7 below shows the fusion bonded plate heat exchanger.



GRAPH 7. Fusion bonded plate heat exchanger (Alfa Laval 2010)

3.6 Lamella heat exchanger

Lamella heat exchanger is made up of a set of parallel welded thin plate, which forms a rectangular channel when placed longitudinally in a shell. The lamellas are pairs of thin flat plate usually fitted with gaskets to prevent leakages. This type of plate heat exchanger is frequently employed by the pulp-paper, chemical process industries to recover process heat. The operating pressures are up to 3.45MPa and temperature limits is between 200°C to 500°C (Kakac & Liu 2002.)

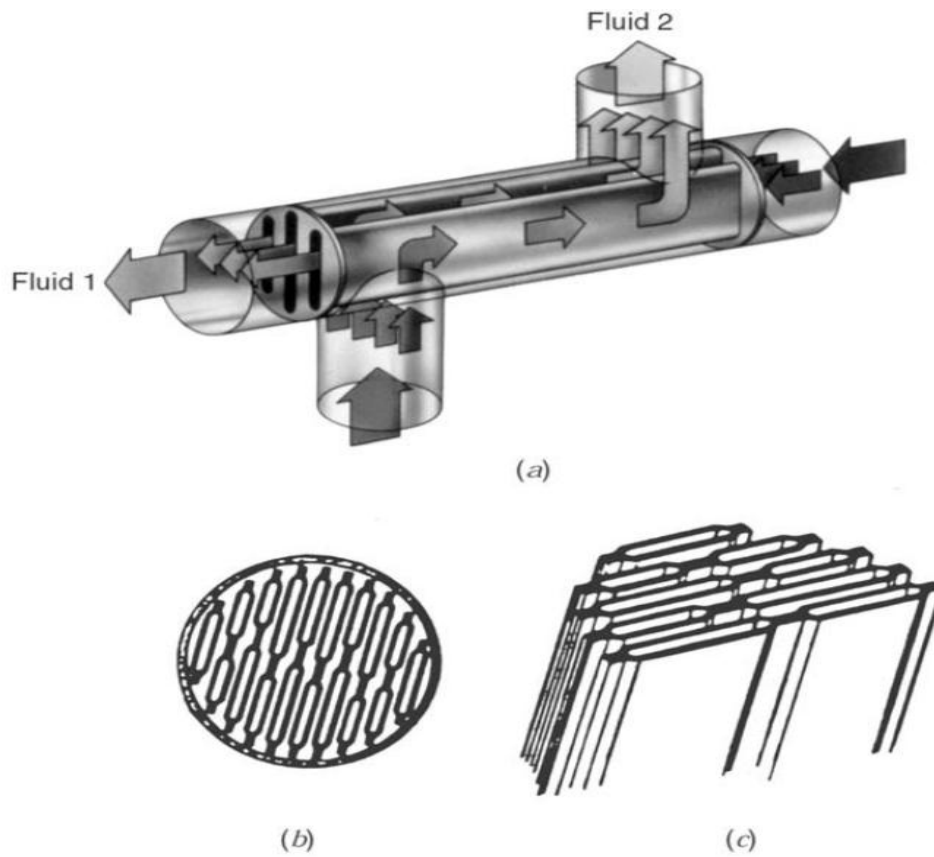

GRAPH 8. Cross section of the lamella heat exchanger showing the lamellas (Alfa Laval 2003)

4 DESIGN AND OPERATION PROCEDURE OF PLATE HEAT EXCHANGERS

The primary objective in the design of plate heat exchangers is the estimation of the minimum heat transfer area required for a given heat duty as this is an important factor to estimate the overall cost of designing the plate heat exchanger. In the previous section of this work was discussed briefly the different types of plate heat exchangers that are used for different applications in the manufacturing industries but since one design principle and methodology is used for all of them therefore we are going to extensively use the gasketed plate heat exchanger as our case study in this research.

In section 3.1 of this work, the gasketed plate heat exchanger was described briefly to consist of a series of rectangular corrugated metal or alloy plates, which are sealed by gaskets and clamped firmly together in a frame with the aid of bolts. The contact of the fluid stream with the corrugated plate causes a turbulent flow, which increases heat transfer between the hot and cold fluid streams respectively. Furthermore, the hot and cold fluid streams flows in and out the corrugated plate via the circular ports located in each corner of the plate. The gaskets are well interlocked and embedded in the plates, which helps to direct the fluid flow. In practice, a single unit of plate heat exchangers can use up to 700 plates, which gives a total heat transfer area of approximately 2500m^2 . (Saunders 1988.)

4.1 Material used for plate design

The materials used in the fabrication of the plates in plate heat exchangers are mainly stainless steel, aluminium, titanium, hastelloy, incoloy, tantalum, monel and nickel based alloy are commonly used. To achieve an efficient heat transfer area which during design it is an important factor to estimate the cost of designing the plate heat exchanger. The plate material must be closely checked to be compatible with the fluid stream in order to avoid fouling and untimely damage of the equipment, which will incur more maintenance cost as well as low output in the end. (Gupta 1986.)

Furthermore, the material selection for plate heat exchangers also depends on the heat duty, mode of heat transfer and the type of fluid stream as mentioned earlier which has to be compatible with the plate material. The principal factor that determines the selection of the plate material is the compatibility of the fluid and heat duty, the manufacturer's choice of material can also be considered as a factor, which also influences the material selection because in most cases they take into consideration the thermal design optimization to achieve better results.

The plate materials can be categorised into four groups as follows. (Wang, Sunden & Manglik 2007.)

1. Alloys of nickel which includes C-276, C-22, C-2000, G-30, D-205, 59, 31, 28, 3033, 825, 686, 400 and nickel 200/201 etc.
2. Stainless steel and alloys which includes 304, 316, 316Ti, 254SMO, 904L, 317, 317LN, 6-XN etc.
3. Titanium, which includes alloys in the following, grades ASTM Gr1, Gr 11 etc.
4. Alloys and non-metal like graphite, copper, tantalum, aluminium etc.

In considering the compatibility between the fluid stream and plate material, the thermal hydraulic design of the respective plate heat exchanger must be taken as an important factor. This is because the thermal resistance of the plate wall has a very important role to play when considering the thermal conductivity values of the plate materials, which indicates that plate materials with higher thermal conductivity values are most preferred in the design of plate heat exchangers. Practically the plates are mass produced with varying thickness within the range of 0.4 to 1.2 mm and are pressed with different design pattern or corrugations, which indicates that they are only available in a limited number with varying sizes and designs. This design pattern of the plates shows that each plate has its own clearly defined specification with regard to the operating conditions and parameters. (Schlunder 2008.)

TABLE 1. Plate material selection (Wang, Sunden & Manglik 2007)

Plate Material	Compatible fluid stream
Stainless steel	Natural cooling water, demineralized water, (< 200ppm) diluted chloride solution, copper sulphate solutions, food products, Pharmaceutical media brews, etc.
Nickel	Caustic (50-70%) solutions
Incoloy	Hydrogen gas/water vapour with mercury carryovers, and acids ($\leq 70^{\circ}\text{C}$)
Hastelloy	Sulphuric and nitric acids
Titanium	Brackish or sea water, (>200ppm) chloride solutions, chlorinated brines and dilute acids($\leq 70^{\circ}\text{C}$)
Titanium-palladium alloys	Dilute nitric and sulphuric acids (10% concentration and $\leq 70^{\circ}\text{C}$)

Table 1 shows the type of fluid that is compatible with the selected plate material, which can be used as a simple selection guide when choosing the design material for the plate heat exchanger. There are several types of corrugated plate design in plate heat exchangers but the most common design is the chevron type with chevron angle that varies between 25° to 65° . The pressure drop and heat transfer characteristics of the plate is determined by the chevron angle on the plate as well.

4.2 Material used for gasket design

The efficiency of the plate heat exchanger highly depends on the gaskets used in the design because its functions are numerous which when absent will pose a challenge for the smooth running of the equipment. Gaskets, which are usually made from single piece elastomers, determine the safety and lifetime leakage proof of the plate heat exchanger. It also determines the flow direction of the fluid stream when in contact with the corrugated plate which avoid intermixing of the hot and cold fluid streams.



GRAPH 9. Gasket setting on a plate heat exchanger (APV 2008)

The mechanical stress and chemical environment are important factors to consider when selecting the gasket material for the design of a plate heat exchanger. Gaskets are manufactured from different polymers such as Nitrile Butadiene Rubber (NBR), Hydrogenated Nitrile (HNBR), Neoprene (CR), Butyl Rubber (BR), Silicone Rubber (SiR) and Ethylene Propylene Diene Monomer (EPDM) etc. In addition, some gaskets are made with asbestos fibre which indicates that selection and manufacturing process involved in obtaining the right material for gasket is quite complex. Other materials that are also used

can contain some vulcanisation chemical and additives, which promotes manufacturing. (Wang, Sunden & Manglik 2007.)

4.3 Operation and selection

There is no discrepancy in the operation of a plate heat exchanger that it functions with the same principle as any other type of heat exchanger. The size, hold up volume and operating condition play a very important role in the operation of plate heat exchangers because both the steady state and transient responses solely depends on these parameters. The working principle of plate heat exchangers clearly indicates that a single pass plate heat exchanger operates like a pure counter flow exchanger because its relative compactness and optimum convective characteristics gives a small approach temperature during operation. This characteristic is very important and useful because it prevents the process fluid media to undergo thermal debasement because they are temperature sensitive. (Wang, Sunden & Manglik 2007.)

Plate heat exchangers due to their compact design and optimum performance are mostly preferred to shell and tube and any other heat exchangers. Furthermore, there is some restrain in the selection, application and operation because the operating temperature and pressure are within a limit of 160 – 250°C and 25 – 30 bars. Due to the malleable nature of the plates, there is deformation that is caused by high pressures of the fluid streams, and the retention capacity of the gasket has to be greatly considered during selection.

In the selection of plate heat exchangers, some factors that restrain the smooth operation are mentioned below. (Wang, Sunden & Manglik 2007.)

1. The complexity of the inter-plate flow channel transmits a high shear rate and shear sensitivity of the media which may cause degradation.
2. The effect of very low flow rate can cause flow mal-distribution in handling very viscous liquids.
3. Pressure drop becomes excessive because plate manufacturers place an upper limit on the size, which restricts applications that requires a very high flow rate in the process industry.

4. Due to very high-pressure drop, plate heat exchangers are unsuitable for air-cooling, gas-to-gas heat exchange and low operating pressure condensation application.

Nevertheless, plate heat exchangers are still considered a better option than the other types of heat exchangers because of their compact design, which makes inspection, maintenance and cleaning easy. In addition, the design methodology varies from very small size to big sized plate heat exchangers depending on the application also the optimum thermal hydraulic performance recompenses for any drawbacks and limitations encountered during operation.

TABLE 2. Operating range of gasketed plate heat exchangers

Operating range	Gasketed plate heat exchanger
Maximum operating pressure	25 bar (30 bar with special construction)
Maximum operating temperature	160°C (250°C with special gaskets)
Maximum flow rate	3600 m ³ /h
Heat transfer coefficient	Up to 7500 W/m ² . K
Heat transfer area	0.1 – 2500 m ²
Maximum connection size	450 mm
Approach Temperature difference	Low as 0.25°C
Heat recovery	Up to 95 %
Number of plates	Up to 2500
Port size	Up to 435 mm
Plate thickness	0.4 to 1.2 mm

4.4 Advantages of plate heat exchangers

The advantages of plate heat exchangers are numerous due to their compact design whereby the components can be easily disassembled for inspection, cleaning and maintenance. The flexibility of the design makes it possible to alter or rearrange the heat transfer area during optimization for an expected load or heat duty change, which may be done by altering the plate size, corrugation patterns, and the pass arrangement respectively. A brief comparison between the shell-tube exchangers and plate heat exchangers shows that fouling can be reduced from 25 to 10 % when a plate heat exchanger is used because the high shear rates, stresses, high turbulent flow pattern and proper mixing are all attributed to the plate corrugation patterns in plate heat exchangers. (Shah & Sekulic 2003.)

Plate heat exchangers usually have a high heat transfer coefficient because the plates are very thin with large surface area and due to the activities taking place on the fluid boundary layers, which leads to achieving a small hydraulic diameter flow passage. Fouling is at a reduced rate compared to shell-tube exchangers, flow arrangement are usually counter flow that aids the approach temperature to reach up to 1°C and a higher heat transfer coefficient is achieved due to the absence of bypass and leakages. Furthermore, this minimizes the design cost and due to the compact design, the equipment can be portable which will occupy less space. Thermal performance is usually high which favours strict temperature control, which is advantageous when using heat sensitive materials because this can optimize the quality of the product. (Shah & Sekulic 2003.)

4.5 Limitations of plate heat exchangers

There are several advantages to use the plate heat exchangers but there are also some limitations as well. The use of plates and gaskets imposes the main limitations, which sets an upper limit on the operating temperature and pressure. In addition, the nature of the type of fluid it can handle is also a limitation because gaskets cannot withstand the use of corrosive or aggressive fluid streams. Fluids with very high viscosity pose a problem, which is because of the flow distribution effects.

4.6 Industrial application

As mentioned briefly in section 2.2 of this research work which the earliest development that introduced the use of plate heat exchanger was used in the dairy industry for milk pasteurization. The use of plate heat exchangers in recent innovative technological processes have expanded greatly because several heat transfer techniques that enhances the development of more optimum compact heat exchangers. This is widely applied today by the refrigeration, air conditioning, petrochemical, food industries etc.

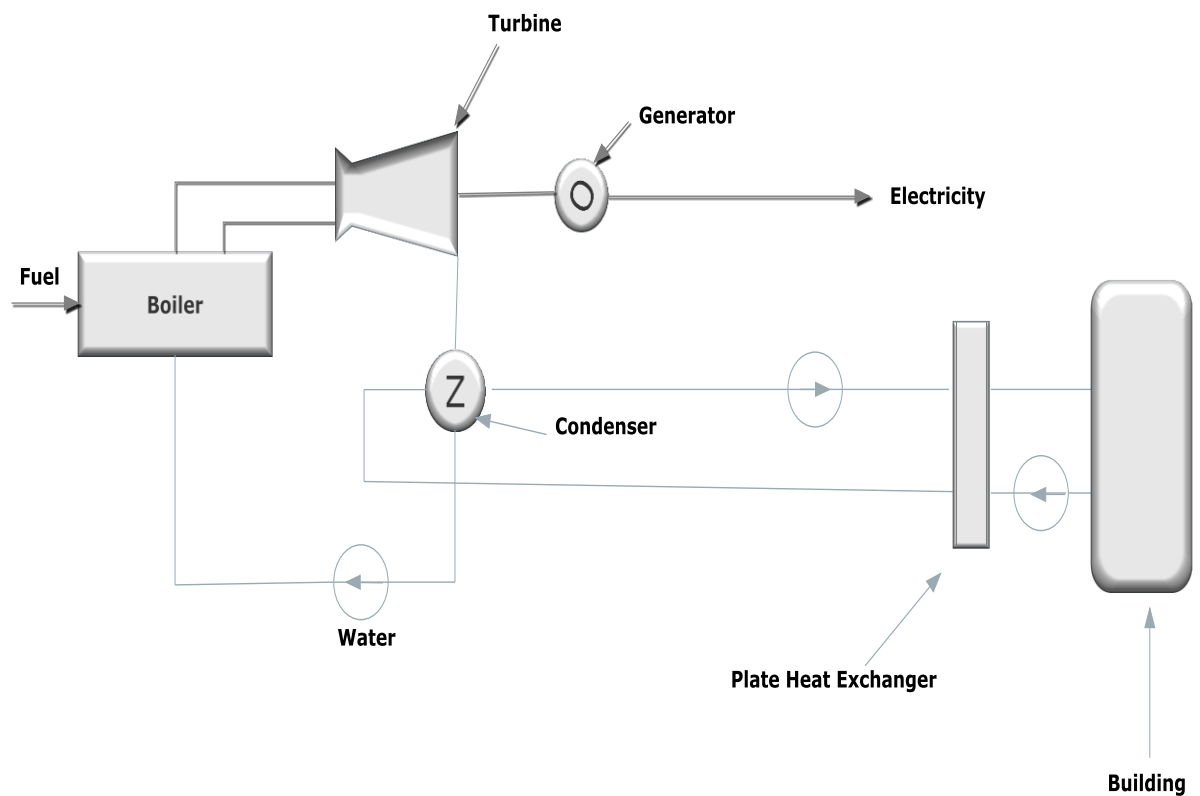

GRAPH 10. A typical industrial application of plate heat exchangers in heat and power generation plant. (Wang, Sunden & Manglik 2007)

5 BASIC DESIGN METHODOLOGY

The same design methodology used in designing other type of heats exchanger is employed when designing the plate heat exchangers as well. In the design process, five important steps that determine an efficient design of plate heat exchangers may be considered. This includes the following as numbered below:

- i. Design/process or problem specification
- ii. Thermal hydraulic design
- iii. Structural/mechanical design which includes operation and maintenance constraints
- iv. Cost and manufacturing considerations
- v. System based optimization and trade-off factors

The stipulated process/design problem for a particular application plate heat exchanger provides all the necessary information needed in achieving an efficient design, which is required for the optimization of the heat transfer process. This implies that the specified process or design challenges must include the type of material used, heat load, fluid streams, and pressure drop constraints. The mechanical or structural integrity of the heat exchanger that the operating condition is under a steady and transient state must be included in the mechanical design process of the plate heat exchanger. In addition, several international, national and relevant local codifications or standards can be strictly adhered to in the mechanical design. In order to carry out an efficient system based optimization which the manufacturer can estimate the required cost to enable an appropriate trade-offs can be considered as well. (Wang, Sunden & Manglik 2007.)

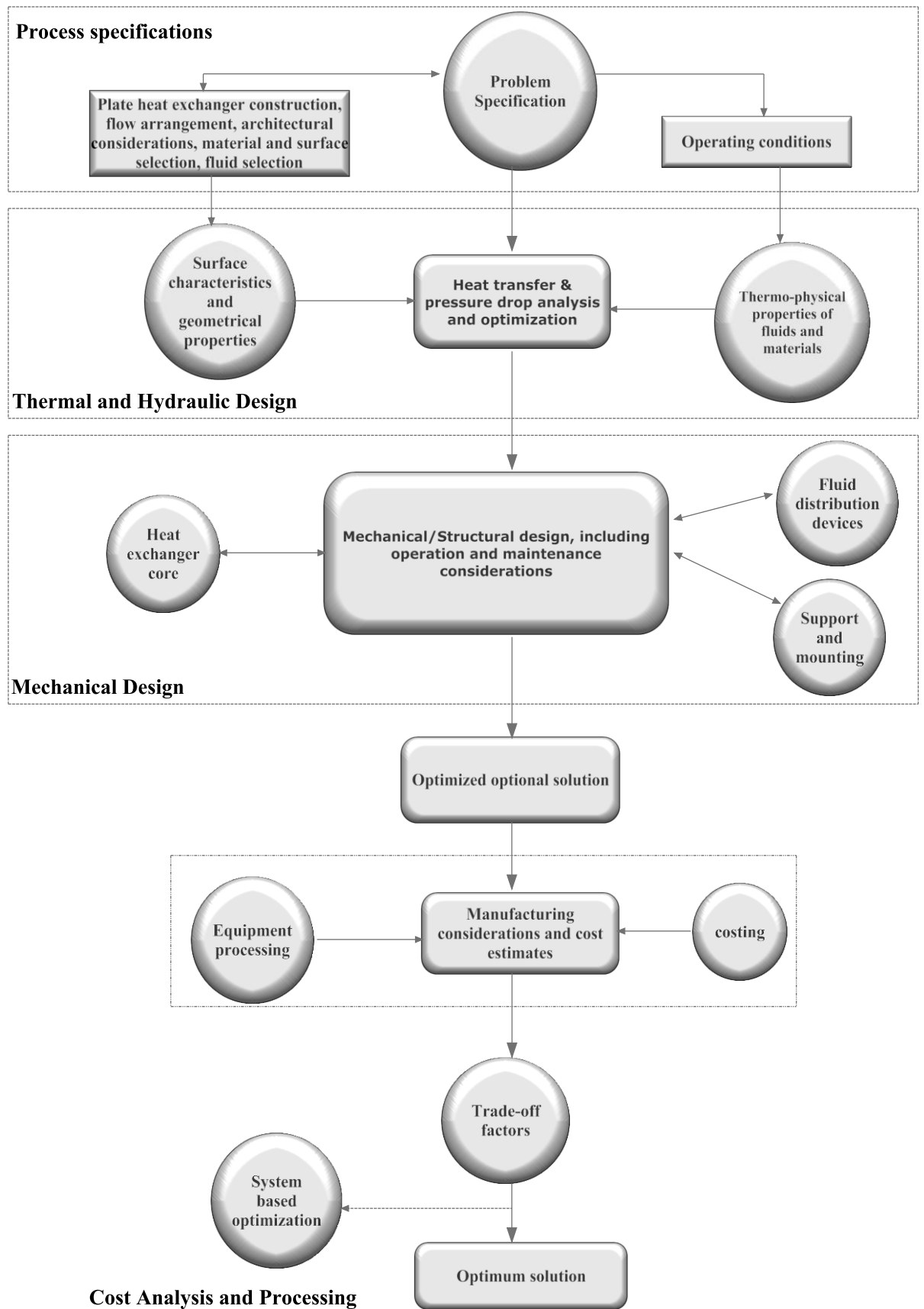

GRAPH 11. Overview of plate heat exchanger design methodology (Shah & Sekulic 2003)

5.1 Thermal hydraulic design

The thermal hydraulic design of heat exchangers takes into consideration some specific quantities like the detailed dimensional size, flow arrangement, thermal hydraulic properties and the optimum operating conditions of the fluid stream, which includes the flow rates, inlet/outlet temperatures, fouling factors, pressure drop etc. In the construction of plate heat exchangers, the thermal hydraulic design methodology faces two important problem specifications, which includes the rating and sizing of the exchanger. The sizing problem may be solved by taking into consideration the type of construction, flow arrangements, detailed dimensional size of the exchanger. In addition, the operating conditions of the fluid streams must be analysed which includes the inlet/outlet temperatures and flow rates respectively. Furthermore, the heat load or duty and pressure drop constraints must be determined as well in order to achieve an optimal design. (Wang, Sunden & Manglik 2007.)

5.2 Flow arrangement of the fluid stream

In the design of plate heat exchangers considering the thermal hydraulic parameters, three different type of flow arrangement are employed for the hot and cold fluid streams, which includes the following below:

- I. Parallel flow arrangement with two fluid streams flowing in the same direction as shown in graph 12.
- II. Counter flow arrangement with two fluid stream flowing in opposite directions as shown in graph 13.
- III. Multi arrangement whereby the path of one fluid stream is reversed through the flow length two or more times if possible as shown in graph 14.

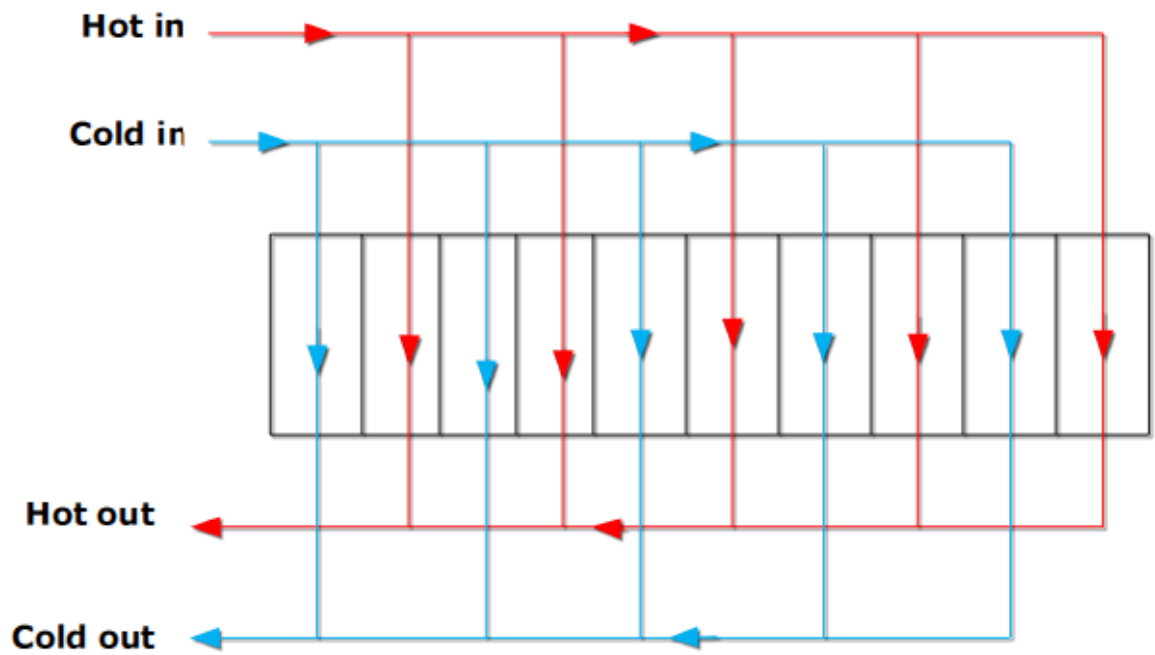

GRAPH 12. Parallel flow arrangement in a two fluid plate heat exchanger (Uwe 2011)

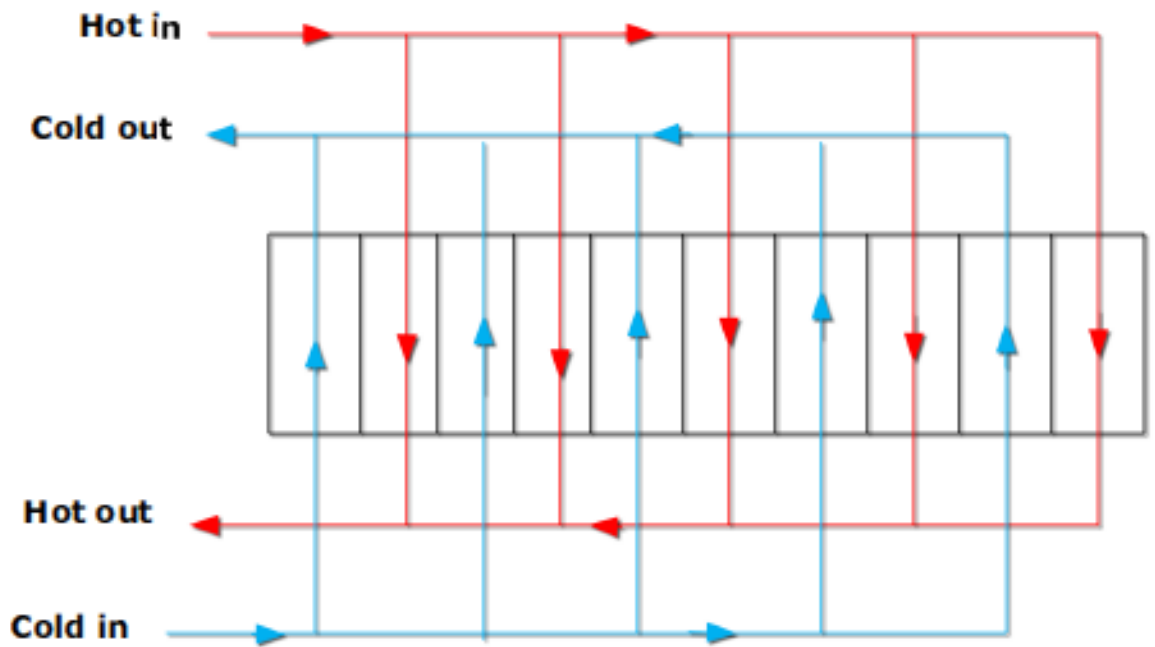

GRAPH 13. Counter flow arrangement in a two fluid plate heat exchanger (Uwe 2011)

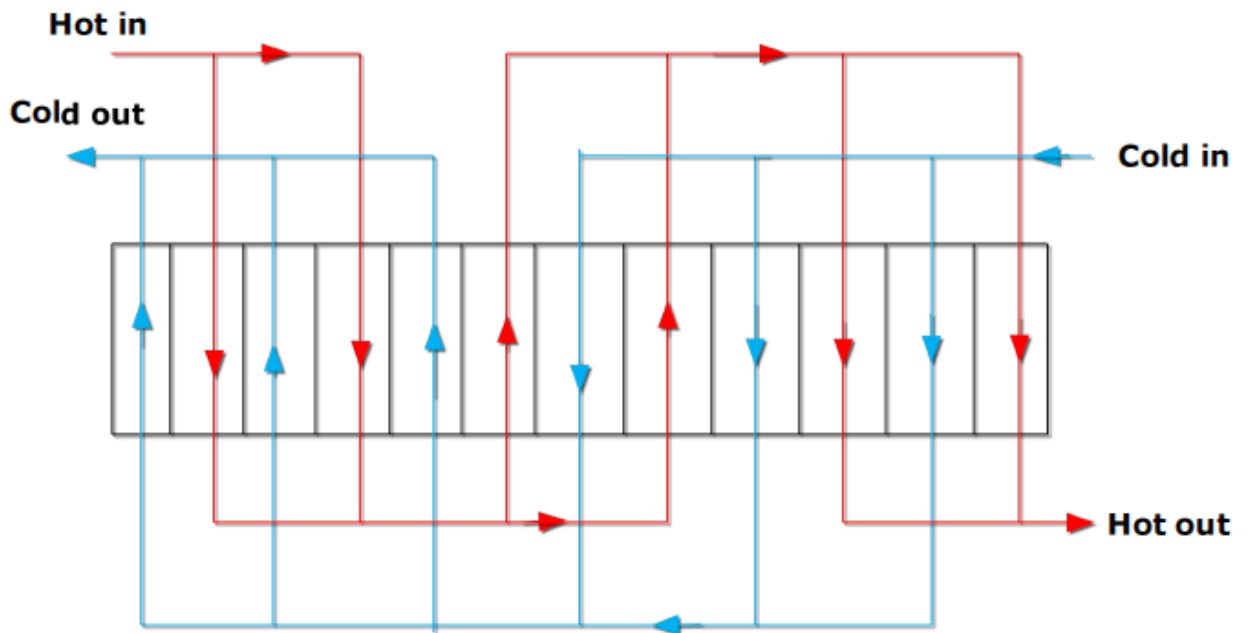

GRAPH 14. Typical multi pass arrangement in a two fluid plate heat exchanger (Uwe 2011)

5.3 Temperature distribution

The temperature of the fluid streams in the plate heat exchanger varies along their flow path because of the temperature gradient and the type of flow distribution, which usually varies across the plate during heat transfer. In the parallel flow arrangement, whereby two fluid streams flowing in the same direction it is observed that the final temperature of the cold fluid stream is always less than the outlet temperature of the hot fluid stream. While in the case of the counter flow arrangement, the temperature of the cold fluid stream may be observed to be higher than the outlet temperature of the hot fluid stream because of the favourable temperature gradient. This implies that there is a great thermodynamic advantage over the parallel flow arrangement.

The illustration on graph 14 and 15 below shows the inlet/outlet temperatures of the fluid stream plotted against the heat transfer area for a single-phase flow of two fluid streams using two different flow arrangements, which is the parallel flow, and the counter flow arrangement respectively. As shown on the graph the heat transfer area is represented on the x-axis and the fluid streams temperature is on the y-axis.

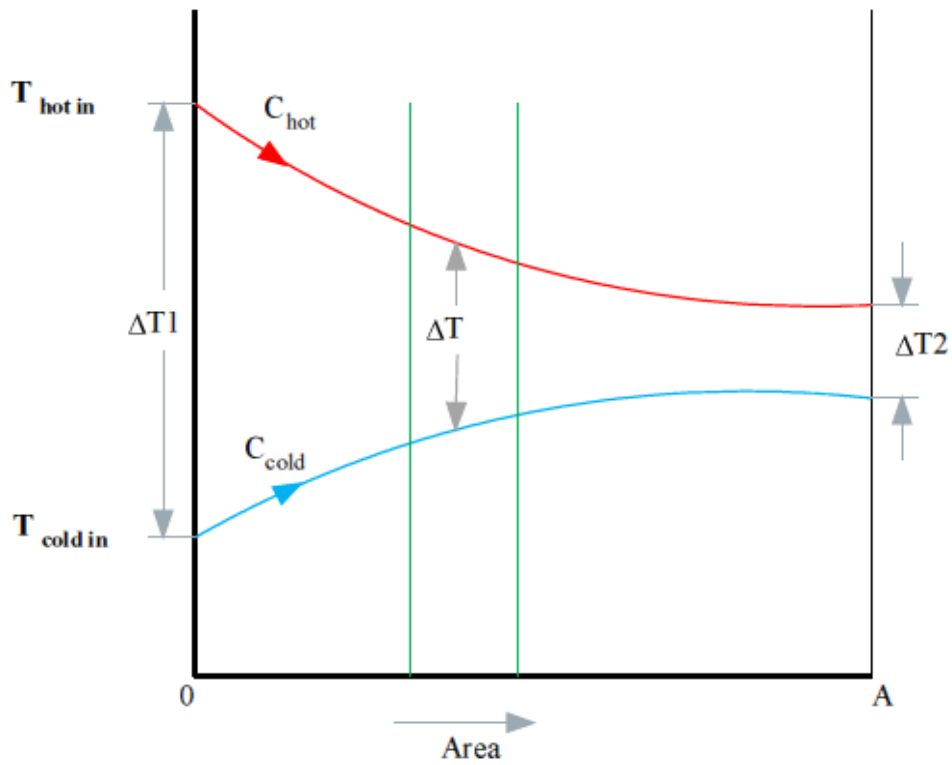

GRAPH 15. Temperature distribution in parallel flow arrangement (Uwe 2011)

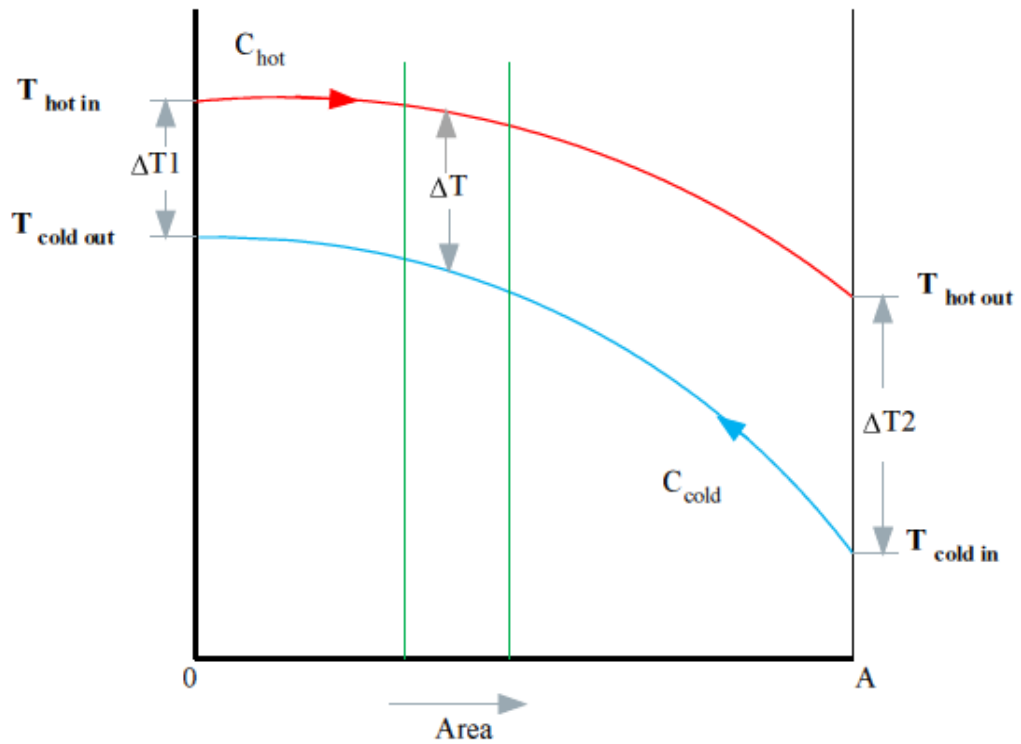

GRAPH 16. Temperature distribution in counter flow arrangement

5.4 Design equations and energy balances

The overall energy balance of a plate heat exchanger can be determined by the application of the first law of thermodynamics whereby the total heat transfer rate in the hot and cold fluid streams are equal. Therefore, this implies that the total heat transfer rate can be calculated from either the hot or the cold fluid streams respectively. (Kakaç & Liu 2002.)

$$Q = C_h(T_{h,i} - T_{h,o}) \quad (1)$$

$$Q = C_c(T_{c,o} - T_{c,i}) \quad (2)$$

$$Q_r = \dot{m}_h C_{P,h} \Delta T_h = \dot{m}_c C_{P,c} \Delta T_c \quad (3)$$

Where $T_{c,i}$ and $T_{c,o}$ are the inlet/outlet temperatures of the cold fluid stream, and \dot{m}_h is the mass flow rate of the hot fluid stream and $C_{P,h}$ is the specific heat capacity of the hot fluid stream. The temperature difference between the inlet and outlet hot fluid stream is ΔT_h .

The logarithmic mean temperature difference LMTD gives the appropriate average temperature difference between the hot and cold fluid streams over the entire length of the heat exchanger. This method will be used extensively in this research in the design of plate heat exchangers and can be obtained using the LMTD equation as expressed below:

$$LMTD = \frac{(T_{h,i} - T_{c,o}) - (T_{h,o} - T_{c,i})}{\ln \left[\frac{(T_{h,i} - T_{c,o})}{(T_{h,o} - T_{c,i})} \right]} \quad (4)$$

The overall heat transfer coefficient in a plate heat exchanger is usually presented as a function of the convective heat transfer coefficient, which can sometimes be referred to as the resistance in the two fluid streams. This can be calculated from the equation below:

$$U = \frac{Q}{A_n LMTD} \quad (5)$$

$$U_f = \frac{Q_f}{A_e FLMTD} \quad (6)$$

Where U is the overall heat transfer coefficient, A_n is the nominal heat transfer surface area and Q is the rate of heat transfer. Equation 5 can be used conveniently to calculate the overall heat transfer coefficient when the total surface area is known. In addition equation (6) shows the overall heat transfer coefficient U_f under fouled condition whereby a correction factor F is must be applied in parallel flow arrangement. (Shah & Sekulic 2003.)

To estimate the total number of effective plates is illustrated in the equation below.

$$N_e = N_t - 2 \quad (7)$$

The hydraulic diameter D_h in plate heat exchangers arises as a result of the corrugation in plates which form a three dimensional flow path with a nominal opening twice the pressing depth of the plate. The size of the hydraulic diameter in plate heat exchangers usually ranges from 5-10 mm and this is can be calculated using the equation below:

$$D_h = \frac{4 \times \text{Channel flow area } A}{\text{Wetted perimeter } P_e} = \frac{2b}{\phi} \quad (8)$$

Where A is the area of cross sectional flow channel, P_e is wetted perimeter of the periphery of the exchanger. The symbols b , ϕ are the channel spacing and wetted surface or enlargement factor, which is usually issued by the manufacturer.

The increase in the channel mass velocity leads to an increase in the frictional pressure drop for an application with a single-phase flow. The channel mass velocity G_c , can be calculated from the expressions below:

$$G_c = \frac{\dot{m}}{N_{cp} b L_w} \quad (9)$$

$$N_{cp} = \frac{N_t - 1}{2N_p} \quad (10)$$

$$b = p - \delta_p \quad (11)$$

$$L_w = L_h + D_p \quad (12)$$

$$p = \frac{\text{Compressed plate pact length, } L_c}{\text{Total number of plates, } N_t} \quad (13)$$

Where N_{cp} is the number of flow channel per pass and N_t, N_p is the total number of plate and number of passes respectively. The channel spacing b and plate pitch p is required for the calculation of the mass velocity and the Reynolds number respectively. The Reynolds Re , Prandtl Pr , and Nusselt Nu numbers are dimensionless numbers characterizing forced convection and free convection flows for single-phase flow fluid streams in a plate heat exchanger. The expressions below illustrate how they can be calculated:

$$Re = \frac{\rho u_p D_h}{\mu} \quad (14)$$

$$Pr = \frac{C_p \mu}{k} \quad (15)$$

$$Nu = \frac{h D_h}{k} = 0.36 Re^{\frac{2}{3}} Pr^{\frac{1}{3}} \quad (16)$$

The relationship between the fouling factor and the overall heat transfer coefficient is due to the convective heat transfer coefficient in the two fluid streams, which their fouling and thermal resistances are conducted through the plate thickness. Therefore, the overall heat transfer coefficient can be calculated as well from the following expression:

$$\frac{1}{U} = \frac{1}{h_h} + \frac{1}{h_c} + \frac{\delta_p}{k_p} + R_{f,h} + R_{f,c} \quad (17)$$

Where k_p is the thermal conductivity of the plate material, δ_p is the thickness of the plate and the fouling resistance on the plate surfaces on the hot and cold fluid stream sides is $R_{f,h}$ and $R_{f,c}$ respectively.

Plate heat exchangers pressure drop is related with the inlet and outlet manifolds, ports and pressure drop within the flow passage in the plates. In most cases, the pressure drop is due to the elevation or height change for a vertical flow in the plate heat exchanger. Practically it is always suggested to control the pressure drop as much as possible since it plays an important role in the effective operation of the plate heat exchanger. Therefore, the total pressure drop may consist of several types of parameters as shown in the expression below. (Shah and Sekulić 2003.)

$$\Delta P_t = \Delta P_c + \Delta P_p \quad (18)$$

Where the pressure drop due to friction in the flow channel is ΔP_c , the port pressure drop is ΔP_p which the summation gives the total pressure drop of other pressure losses that may be caused by the flow distribution pattern in the inlet/outlet manifolds and ports.

$$\Delta P_p = 1.4N_p \frac{G_p^2}{2\rho} \quad (19)$$

$$G_p = \frac{\dot{m}}{\frac{\pi D_p^2}{4}} \quad (20)$$

$$\Delta P_c = 4f \frac{L_{eff} N_p}{D_h} \frac{G^2}{2\rho} \left(\frac{\mu_b}{\mu_w} \right)^{-0.17} \quad (21)$$

Where L_{eff} is the effective length of the fluid flow path between the inlet and outlet ports, the friction factor f is given below.

$$f = \frac{k_p}{Re^m} \quad (22)$$

The total effective area can obtain by employing the following relationship:

$$A_T = \frac{\text{Actual effective area } A_a}{\text{Projected plate area } A_{pr}} \quad (23)$$

The projected plate area A_{pr} can also be determined from the relationship below whereby it is related to the estimated port distances L_v , L_h and the port diameter D_p as well.

$$A_p = L_p L_w \quad (24)$$

$$L_p \cong L_v - D_p \quad (25)$$

$$L_w \cong L_h + D_p \quad (26)$$

The enlargement factor ϕ , which relies more on the corrugated properties of the plate, varies between 1.15 and 1.25 respectively. This can be estimated using the relationship below:

$$\phi = \frac{\text{Single plate area, } A_s}{\text{Projected plate area, } A_{pr}} \quad (27)$$

$$A_s = \frac{A_T}{N_e} \quad (28)$$

5.5 Design method

The design method used in this research work employs a systematic design approach, which is developed for the simulation of plate heat exchangers operating in steady state with generalized configuration. The approach used in this work take into consideration the calculation of all the parameters needed for the design and construction of the plate heat exchanger, which the results are closely compared with the results from literature using the same parameters with the design equations. The approach or method with the best optimum design parameters is recommended for the design .The calculated parameters include the number of plates, plate dimensional properties, the inlet/outlet temperatures for the hot and cold fluid stream is usually given. However, in achieving the required heat transfer surface area the plate amount used is closely checked since it plays an important role in obtaining the required area and the flow channel velocities, physical properties of the hot/cold fluid streams. The schematic diagram below show the design methodology used in this research work for the optimum design of the plate heat exchanger.

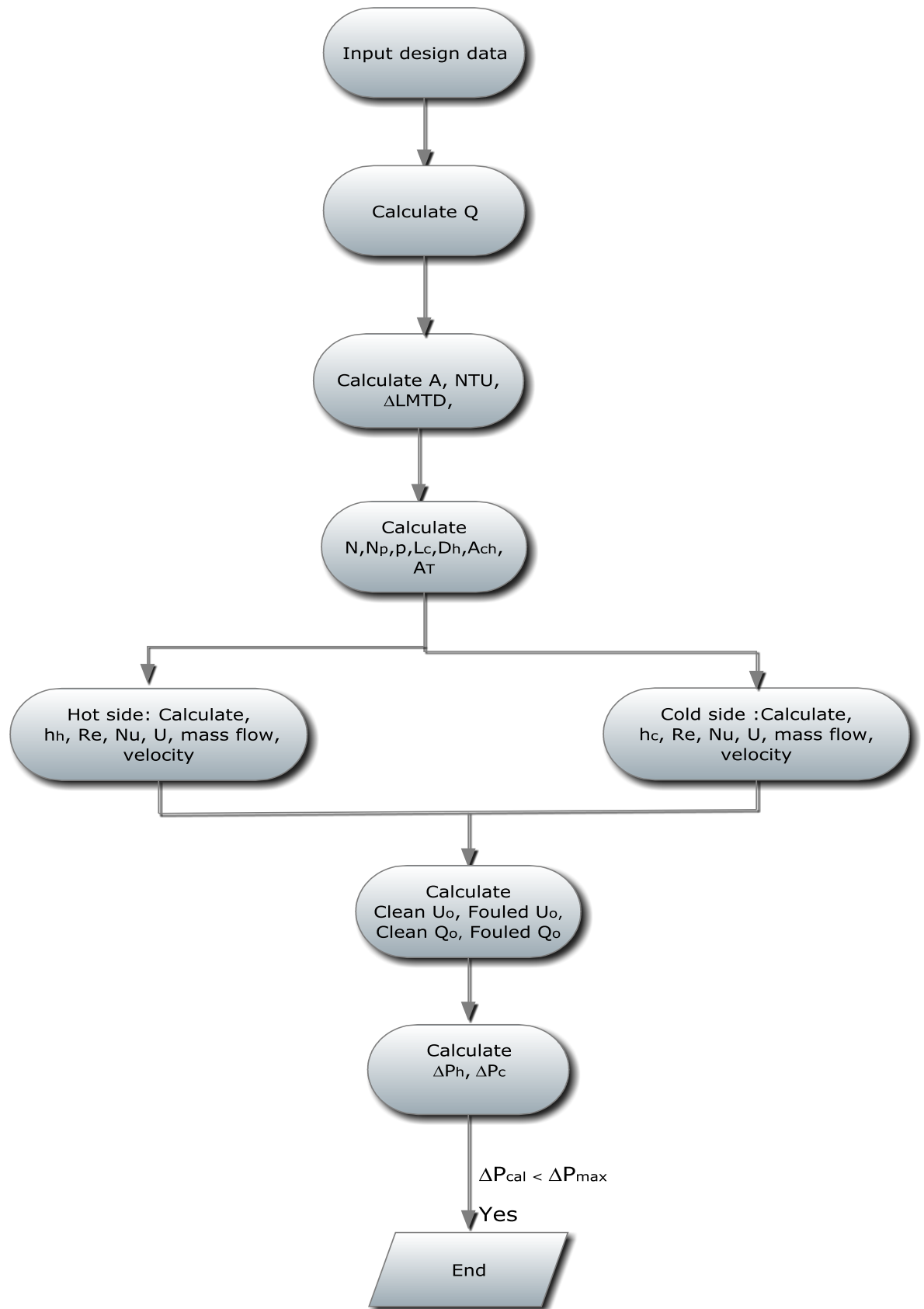

GRAPH 17. Diagrammatic design methodology (Uwe 2011)

The methodology above is based on the fact that one variable either the total effective area or the number of plates must be defined or assumed in order for the design program to calculate the other variables. However to calculate the overall heat transfer coefficient the fouled and cleaned must also be assumed. In addition to this, the maximum pressure drop must be considered as well because the calculated pressure must be less than the maximum assumed pressure. Furthermore, when the calculated pressure drop exceeds the value of the maximum pressure drop, it is suggested that the designer must increase the number of plate in order to meet up with the design specification and heat duty demands.

The major priority we have to consider when designing the plate heat exchanger is the determination of the surface area required for the specified heat duty by employing the given temperature difference and taking into consideration the maximum pressure drops allowed in the design specification. The following parameters are calculated by employing the design methodology above:

- I. Heat load required clean or fouled
- II. Duty clean/dirty calculations
- III. Total effective area
- IV. Surface area calculations
- V. Number of plates
- VI. Overall heat transfer coefficient (clean /dirty)
- VII. Total Pressure drop for hot fluid and cold fluid streams respectively
- VIII. Dimensions of the plate are calculated as well
- IX. Calculation of velocity through ports, mass velocity through channels and ports
- X. Calculation of Reynolds Re and Nusselt Nu numbers
- XI. Calculation of heat transfer coefficients etc

5.6 Case study of design methodology

A given cold raw water stream was heated with a hot distilled water stream, the flow rate of the hot distilled water stream is 180000kg/h which enters into the plate heat exchanger at 305K and leaves at 298K after heat is exchanged with the cold raw water stream. The cold stream has an unknown flow rate and the inlet/outlet temperatures of 293K and

295.3K respectively. The maximum allowable pressure drop for the two fluid streams is 100kpa. The detailed process design specification to determine the heat transfer area is given in the table below:

TABLE 3. Properties of the fluid streams (Kakaç & Liu 2002)

Stream properties	Hot fluid	Cold fluid
Fluids	Distilled water	Raw water
Flow rates (kg/h)	180000	-
Inlet temperature (K)	305	293
Outlet temperature (K)	298	295.3
Maximum allowable pressure drop (kpa)	100	100
Fouling factor ($m^2.K/W$)	0.00005	0
Specific heat capacity ($J/kg.K$)	4178.7	4181.6
Viscosity ($kg/m.s$)	0.00082	0.00098
Thermal conductivity ($W/m.K$)	0.6144	0.6044
Density (kg/m^3)	996.41	998.2
Prandtl number	5.64	6.80

TABLE 4. Constructional data for proposed plate heat exchanger design (Kakaç & Liu 2002)

Plate Material	Stainless steel (SMO-254)
Plate thickness (mm)	0.6
Chevron angle (degrees)	45
Total number of plates	105
Enlargement factor	1.25
Number of passes	1/1
Assumed overall heat transfer coefficient (clean/fouled) $W/m^2.K$	8000/4500
Port diameter, D_p (mm)	200
Vertical port length, L_v (m)	1.55
Horizontal port width, L_h (m)	0.43
Channel spacing (mm)	2.83
Plate material thermal conductivity ($W/m^2.K$)	17.5
Gasket material	Viton
Frame type	Mild steel
Total effective area (m^2)	110

The results from the design simulation software gave the following results, which are compared with the respective results from literature using the design equations. The proposed plate heat exchanger design data sheet can be seen on Table 5.

TABLE 5. Design simulation calculation summary

Stream Properties	Hot Stream		Cold Stream	
Name	Distilled water		Raw water	
Mass Flowrate (kg/h)	180.000		547448.03	
Mass Flow per channel (kg/s)	0.96		2.92	
Velocity through port (m/s)	1.60		4.85	
Average temperature (°K)	301.5		294	
Temperatures (In/Out) (°K)	305	298	293	295.3
Density (kg/m ³)	996.41		998.20	
Specific heat Capacity [kJ/(kg.°K)]	4178.7		4181.6	
Viscosity [N.s/m ²]	8.2E-04		9.8E-04	
Thermal Conductivity [W/(m.°K)]	0.6144		0.6044	
Reynolds Number Re	2978.3		7578.59	
Prandth Number Pr	5.64		6.80	
Nusselt Number Nu	122.47		249.86	
Port mass Velocity [kg/(m ² .s)]	1591.49		4840.50	
Number of Passes	1		1	
Heat Transfer Coefficient [W/(m ² .°K)]	16610.15		33336.23	
Heat Transfer Analysis				
Heat Load (kW)			1462.55	
LMTD (°K)			7.09	
Number of Transfer Unit, NTU (hot/cold stream)			0.99	0.99
Clean Heat Transfer Coefficient (Calculated/Assumed) [W/(m ² .°K)]			8032.95	8000
Fouled Heat Transfer Coefficient (Calculated/Assumed) [W/(m ² .°K)]			5731.08	4500
Heat Duty (Clean/fouled) (kW)			6236.42	4449.35
Pressure Drop Analysis				
Channel pressure Drop (kpa)	75.9		60.09	
Port Pressure Drop (kpa)	1.65		15.26	
Total Pressure Drop (Calculated/Allowed) (kpa)	77.55	100	75.35	100
Plate properties				
Number of Plates	105		Lv (m)	1.55
Chevron Angle (deg)	45		Lp (m)	1.35
Number of Channels per Pass	52		Dp (mm)	200
Plate Pitch (mm)	3.43		Lh (m)	0.43
Compressed Plate Pack Length (mm)	360.15		Lw (m)	0.63
Channel Equivalent Diameter (mm)	4.53		Pt (mm)	0.6
Channel Flow area (m ²)	0.0018			
Total Effective Area (m ²)	109.5			
Surface Area (m ²)	45.84			

5.6.1 Theoretical solution

The methodology used to analyse the case study mentioned above in section 5.6 employs the simulation design method but in this case, the theoretical methods from literature employs design equations to calculate and analyse the solution data of the given case study as expressed below.

This shows a stepwise performance design analysis whereby the heat load can be calculated from equation (3):

$$\begin{aligned} Q_r &= \dot{m}_h C_{P,h} \Delta T_h = \dot{m}_c C_{P,c} \Delta T_c \\ &= 50 \times 4178.7 \times (305 - 298) = \dot{m}_c \times 4181.6 \times (295.3 - 293) \end{aligned}$$

$$\dot{m}_c = 152.1 \text{ kg/s}$$

Therefore, the heat load Q_r is 1462.85 kW.

The logarithmic mean temperature difference LMTD can be calculated from equation (4)

$$\begin{aligned} LMTD &= \frac{(T_{h,i} - T_{c,o}) - (T_{h,o} - T_{c,i})}{\ln \left[\frac{(T_{h,i} - T_{c,o})}{(T_{h,o} - T_{c,i})} \right]} \\ LMTD &= \frac{(305 - 295.3) - (298 - 293)}{\ln \left[\frac{(305 - 295.3)}{(298 - 293)} \right]} = 7.09 \text{ K} \end{aligned}$$

Heat transfer surface area of the plate can be calculated by the application of equation (6) as follows:

$$\begin{aligned} A_e &= \frac{Q}{U_f LMTD} \\ &= \frac{1462850}{4500 \times 7.09} \end{aligned}$$

$$A_e = 45.85 \text{ m}^2$$

The effective number of plates can be estimated using equation (7):

$$N_e = N_t - 2$$

$$N_e = 105 - 2 = 103$$

The number of transfer, NTU can be estimated for the hot and cold fluid streams:

$$\begin{aligned}
 NTU_c &= \frac{T_{c2} - T_{c1}}{LMTD} \\
 &= \frac{295.3 - 293}{7.09} = 0.99
 \end{aligned}$$

For the hot fluid side:

$$\begin{aligned}
 NTU_h &= \frac{T_{h1} - T_{h2}}{LMTD} \\
 &= \frac{305 - 298}{7.09} = 0.99
 \end{aligned}$$

The channel flow area A_{ch} can be estimated from the relationships below:

$$\begin{aligned}
 L_w &= L_h + D_p \\
 &= 0.43 + 0.2 = 0.63 \text{ m}
 \end{aligned}$$

Therefore,

$$\begin{aligned}
 A_{ch} &= bL_w = 0.0023 \times 0.63 \\
 &= 0.0018 \text{ m}^2
 \end{aligned}$$

Applying equation (28) the heat transfer area of a single plate can be calculated as expressed below.

$$\begin{aligned}
 A_s &= \frac{A_T}{N_e} \\
 &= \frac{110}{103} = 1.068 \text{ m}^2
 \end{aligned}$$

The designer has specified the enlargement factor but we can verify it by using equation (27) but we must first calculate the projected length A_p using equations (24, 25, 26 and 28).

$$\begin{aligned}
 L_p &\cong L_v - D_p \\
 &\cong 1.55 - 0.2 \cong 1.35 \text{ m}
 \end{aligned}$$

Therefore, since L_w has been calculated above as 0.63 m, A_p can be expressed below as shown:

$$\begin{aligned}
 A_p &= L_p L_w \\
 &= 1.35 \times 0.63 = 0.85 \text{ m}^2
 \end{aligned}$$

This implies that the enlargement factor can thus be obtained with the following expression below:

$$\begin{aligned}\phi &= \frac{\text{single plate area, } A_s}{\text{Projected area, } A_p} \\ &= \frac{1.068}{0.85} = 1.26\end{aligned}$$

The number of channels per pass N_{cp} can be calculated using equation (10) as expressed below:

$$\begin{aligned}N_{cp} &= \frac{N_t - 1}{2N_p} \\ &= \frac{105 - 1}{2 \times 1} = 52 \text{ channels per pass}\end{aligned}$$

The flow channel velocity u_{ch} for the hot and cold fluid streams can be calculated using the expression below.

$$u_{ch} = \frac{\dot{m}}{\rho A_{ch} N_{cp}}$$

$$u_{chc} = \frac{152.1}{998.2 \times 0.0018 \times 52} = 1.63 \text{ m/s}$$

$$u_{chh} = \frac{50}{996.41 \times 0.0018 \times 52} = 0.54 \text{ m/s}$$

Heat transfer analysis:

The mass flow per channel in the hot side and cold side is estimated in this case by the relationships below.

$$\begin{aligned}\text{Mass flow per channel on cold side} &= \frac{\dot{m}_c}{N_{cp}} \\ &= \frac{152.1}{52} = 2.93 \text{ kg/s}\end{aligned}$$

$$\begin{aligned} \text{Mass flow per channel on hot side} &= \frac{\dot{m}_h}{N_{cp}} \\ &= \frac{50}{52} = 0.96 \text{ kg/s} \end{aligned}$$

The flow channel hydraulic diameter can be deduced from equation (8) as expressed in the following relationship.

$$\begin{aligned} D_h &= \frac{4 \times \text{Channel flow area } A}{\text{Wetted perimeter } P_e} = \frac{2b}{\phi} \\ &= \frac{2 \times 2.83}{1.26} = 4.5 \text{ mm} \end{aligned}$$

$$\text{Port Area, } P_A = \frac{\pi D_p^2}{4}$$

$$P_A = \frac{3.14 \times 0.2^2}{4} = 0.0314 \text{ m}^2$$

The port mass velocities for the hot and cold streams can be estimated by employing equation (9) to deduce the respective mass flow velocities as expressed below.

$$\begin{aligned} G_c &= \frac{\dot{m}_c}{N_{cp} b L_w} = \frac{\dot{m}_c}{P_A} \\ &= \frac{152.1}{0.0314} = 4843.95 \text{ kg/m}^2\text{s} \end{aligned}$$

$$\begin{aligned} G_h &= \frac{\dot{m}_h}{N_{cp} b L_w} = \frac{\dot{m}_h}{P_A} \\ &= \frac{50}{0.0314} = 1592.36 \text{ kg/m}^2\text{s} \end{aligned}$$

The Reynolds number for the hot and cold fluid stream can be calculated as well by employing equation (14) as expressed below.

$$\begin{aligned} Re_c &= \frac{\rho u_{ch} D_h}{\mu_c} \\ &= \frac{998.2 \times 1.63 \times 0.0045}{0.00098} = 7471.22 \end{aligned}$$

$$Re_h = \frac{\rho u_{ch} D_h}{\mu_h}$$

$$= \frac{996.41 \times 0.54 \times 0.0045}{0.00082} = 2952.78$$

The dimensionless Nusselt number Nu for the hot and cold fluid streams can be calculated by applying equation (16) from literature as show below.

$$Nu = \frac{hD_h}{k} = 0.36Re^{\frac{2}{3}}Pr^{\frac{1}{3}}$$

$$Nu_c = 0.36 \times 7471.22^{0.66} \times 6.8^{0.33} = 244.04$$

$$Nu_h = 0.36 \times 2952.78^{0.66} \times 5.64^{0.33} = 124.33$$

Heat transfer coefficient for the hot and cold fluid streams can also be estimated by applying equation:

$$h_c = \frac{Nu_c k}{D_h}$$

$$= \frac{244.04 \times 0.6044}{0.0045} = 32777.28 \text{ W/m}^2\text{K}$$

$$h_h = \frac{Nu_h k}{D_h}$$

$$= \frac{124.33 \times 0.6144}{0.0045} = 16975.20 \text{ W/m}^2\text{K}$$

The clean heat transfer coefficient can be calculated by employing equation (17) as expressed below.

$$\frac{1}{U_c} = \frac{1}{h_c} + \frac{1}{h_h} + \frac{Pt}{k_p}$$

$$= \frac{1}{32777.28} + \frac{1}{16975.20} + \frac{0.0006}{17.5}$$

$$U_c = 8083.80 \text{ W/m}^2\text{K}$$

The fouled heat transfer coefficient can be calculated from the following equation from literature as expressed below.

$$\frac{1}{U_f} = \frac{1}{U_c} + f$$

$$= \frac{1}{8083.80} + 0.00005$$

$$U_f = 5756.91 \text{ W/m}^2\text{K}$$

The actual heat duties (cleaned/fouled surfaces) can be estimated as well by employing the following equation (5 or 6) below.

$$\begin{aligned} Q_c &= U_c A_e LMTD \\ &= 8083.80 \times 110 \times 7.09 \end{aligned}$$

$$Q_c = 6304.56 \text{ kW}$$

$$\begin{aligned} Q_f &= U_f A_e LMTD \\ &= 5756.91 \times 110 \times 7.09 \end{aligned}$$

$$Q_f = 4489.80 \text{ kW}$$

Pressure drop calculations for the hot and cold stream can be deduced by employing equations (18, 19 and 20) as illustrated below whereby the friction factor is used to aid the estimation of the required pressure drop either on the flow channels or on the ports.

$$\begin{aligned} \Delta P_p &= \frac{1.3 N_p \rho u_p^2}{2} \\ \Delta P_{pc} &= \frac{1.3 \times 1 \times 998.2 \times 4.85^2}{2} = 15.26 \text{ kPa} \\ \Delta P_{ph} &= \frac{1.3 \times 1 \times 996.41 \times 1.6^2}{2} = 1.66 \text{ kPa} \end{aligned}$$

The channel pressure drop for the fluid streams can be estimated by the following expression employing equations (21 and 22) respectively. The values of the constants k_p and m for single-phase pressure loss calculation in plate heat exchanger design method is given as (1.441 and 0.206 for chevron angle 45° and Reynolds number > 300). (Kakac & Liu 2002.)

$$\begin{aligned} f &= \frac{k_p}{Re^m} \\ \Delta P_c &= 4f \frac{L_{eff} N_p}{D_h} \frac{G^2}{2\rho} \left(\frac{\mu_b}{\mu_w} \right)^{-0.17} \end{aligned}$$

For hot side, assume that $\mu_b = \mu_w$

$$f = \frac{1.441}{2954.78^{0.206}} = 0.278$$

$$\Delta P_c = \frac{4 \times 0.278 \times 1.55 \times 1 \times 533.33^2}{0.0045 \times 2 \times 996.41} = 54.70 \text{ kPa}$$

For cold side, assume that $\mu_b = \mu_w$

$$f = \frac{1.441}{7471.22^{0.206}} = 0.229$$

$$\Delta P_c = \frac{4 \times 0.229 \times 1.55 \times 1 \times 1622.22^2}{0.0045 \times 2 \times 998.2} = 416.8 \text{ kPa}$$

The total pressure drop for the hot and cold fluid side can thus be calculated by employing equation (18) from literature as expressed below.

$$\Delta P_t = \Delta P_c + \Delta P_p$$

Hot side:

$$\Delta P_t = 54.70 + 1.66 = 56.36 \text{ kPa}$$

Cold side:

$$\Delta P_t = 416.8 + 15.26 = 432.06 \text{ kPa}$$

6 RESULTS AND DISCUSSION

In this section, the results from the simulation design and literature are compared closely with emphasizing more on the key parameters since the values obtained are numerous during design. The simulation model was applied in such a way that the configuration and design methodology shows that it can be effectively used in optimizing the plate heat exchanger design while targeting the most important factors like minimal operational and capital cost of running the equipment. The practical case study in this work was to design a plate heat exchanger, which is capable of transferring heat from the hot fluid stream to the cold fluid stream by effectively achieving similar results from simulated design program. In addition, theoretical results were obtained by mathematical iterations and analysis from literature by employing design equations.

Furthermore, the results obtained from simulation software and theoretical iteration shows that the materials and parameters employed in the design process were effective because it gave similar results from both methods. Hence, the mass flow rate and the heat load were estimated by the simulation method and when compared to the values in literature gave a very close solution, it shows that the stimulation method can be effectively used in the design process.

The method employed take into consideration some parameters such as the heat transfer coefficient, pressure drop, as well as the heat transfer area. The results obtained illustrates that the iteration made are valid and can be relied on during consequent design. Table 6 shows that the results obtained from the stream properties between the hot and cold fluid of the simulation and theoretical iteration were accurate when compared. However, the pressure drop analyses there were some slight differences between the simulation and iteration methods due to the complexity to deduce the parameters required to achieve the result using iteration method. Thus, the plate properties gave accurate results using the simulation and iteration method.

TABLE 6. Result summary of the design method that gives a key comparison between the two methodologies employed.

Stream Properties	Simulation Program		Theoretical Iteration	
	Hot Stream	Cold Stream	Hot Stream	Cold Stream
Mass Flowrate (kg/h)	180000	547448.03	180000	547560
Mass Flow per channel (kg/s)	0.96	2.92	0.96	2.92
Velocity through port (m/s)	1.60	4.85	1.60	4.85
Reynolds Number Re	2978.30	7578.60	2952.78	7471.22
Nusselt Number Nu	122.47	249.86	124.33	244.04
Port mass Velocity [kg/(m ² .s)]	1591.49	4840.50	1592.35	4843.94
Heat Transfer Coefficient [W/(m ² .°K)]	16610.15	33336.23	16975.20	32777.28
NTU	0.99	0.99	0.99	0.99
Heat Load (kW)	1462.55		1462.85	
LMTD (°K)	7.09		7.09	
Uc [W/(m ² .°K)]	8032.95		8083.80	
Uf [W/(m ² .°K)]	5731.08		5756.91	
Heat Duty (Clean) (kW)	6236.42		6304.56	
Heat Duty (fouled) (kW)	4449.35		4489.80	
Pressure Drop Analysis	Hot Stream	Cold Stream	Hot Stream	Cold Stream
Channel pressure Drop (kpa)	75.9	60.09	54.7	416.8
Port Pressure Drop (kpa)	1.65	15.26	1.66	15.26
Total Pressure Drop (kpa)	77.55	75.35	56.36	432.06
Plate properties				
Number of Channels per Pass	52		52	
Channel Equivalent Diameter (mm)	4.53		4.5	
Channel Flow area (m ²)	0.0018		0.0018	
Surface Area (m ²)	45.84		45.85	

7 CONCLUSION

The research study was based on plate heat exchanger design methodology in the manufacturing and process industries. It employed the use of stimulation and iteration methods to compare the accuracy of the result obtained during the design application.

The objective of this research study was to design a plate heat exchanger, which is capable of transferring heat from the hot fluid stream to the cold fluid stream by effectively achieving similar results from simulated design program and to achieve an efficient method used in the construction and installation of plate heat exchangers.

However, the results obtained during the research shows the design application is effective and can be used as a guide for future optimization purposes. The maximum pressure drop allowed in the design is one of the important parameters or specifications employed and it must be noted that this maximum pressure drop is always higher than the calculated values in both design methods employed in this research work. Hence, it is required to note that when the calculated pressure drop exceeds the maximum allowable pressure, the design must be optimized by adding more plates in order to increase the heat transfer area and correct the necessary design errors.

The simulation method is widely used nowadays and during the course of the research studies, it should be noted that several design simulation software were widely explored but it was observed that due to the fact that most of them are still undergoing future development and cannot be totally relied on.

In suggestion for further research, the iteration method should be encouraged to crosscheck the simulation results in order to minimize and control design errors.

REFERENCES

- Alfa Laval Corporate AB. 2010. Available: <http://www.alfalaval.com/Pages/default.aspx> . Accessed December 8th 2010.
- API Heat Transfer Incorporated. 2010. Available: <http://apiheattransfer.com/> . Accessed December 11th 2010.
- APV heat exchangers. 2010. Available: <http://www.apv.com/> . Accessed 19th December 2010.
- Bejan, A., Kraus, A.D. 2003. Heat transfer handbook. New Jersey, NJ: John Wiley & Sons Inc.
- Cooper, A., Sutor, J.W and Usher, J.D. 1980. Cooling water fouling in plate heat exchangers: Heat transfer engineering. London: Taylor & Francis Group.
- Cooper, A., Usher, J.D. 1988. Plate heat exchangers: Heat exchanger design handbook. Washington DC: Hemisphere.
- Gupta, J.P. 1986. Fundamentals of heat exchanger and pressure vessel technology. Washington DC: Hemisphere.
- Kakac, S., Liu, H. 2002. Heat exchangers selection, rating and thermal design (2nd Ed). Florida, FL: CRC press.
- McCabe, W.L., Smith, J.C., and Harriott, P. 2005. Unit operations of chemical engineering (7th Ed). New York , NY: McGraw-Hill.
- National Heat Exchange Corporation. 2010. Available: <http://www.nationalheatexchange.com/spiral.htm> . Accessed 14th December 2010.
- Process Solutions. 2010. Available: <http://www.heatexchangerguy.com/> . Accessed 17th December 2010.
- Raju, K.S.N, Bansal, J.C. 1983. Plate heat exchangers and their performance. Washington DC : Hemisphere.

Saunders, E.A. 1988. Heat exchangers selection, design and construction. New York, NY: Longman.

Shah, R.K, Sekulic, D.P. 2003. Fundamentals of heat exchanger design. New Jersey, NJ: John Wiley & Sons Inc.

Schlunder, E.U. 2008. Heat exchanger design handbook. New York, NY: Hemisphere publishing corporation.

Wang, L., Sunden B. and Manglik R.M. 2007. Plate heat exchangers: Design application and performance. Southampton: WIT press.

WCR heat exchangers. 2010. Available: <http://www.wcr-regasketing.com/> . Accessed 15th December 2010.

White, F.M. 2005. Fluid mechanics (4th Ed). New York, NY: McGraw-Hill.

Wilcox, D.C. 2000. Turbulence modelling for CFD (2nd Ed). California, CA: DCW Industries.

APPENDIX 1/1

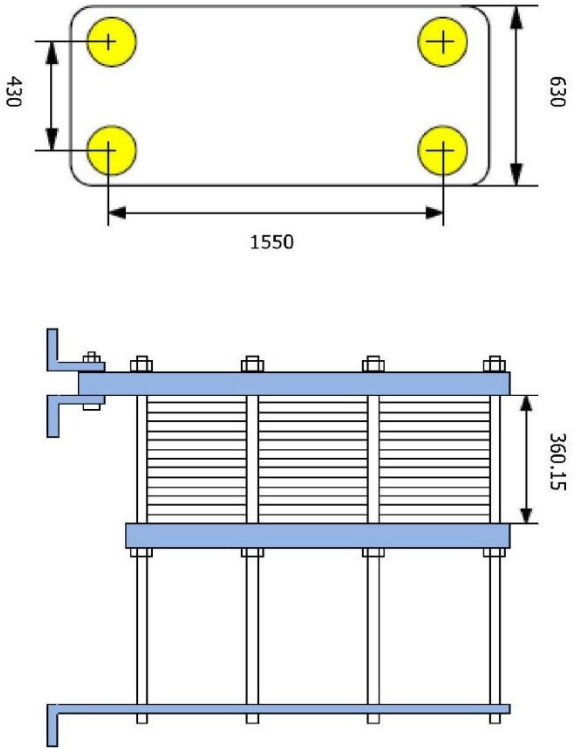

DESIGN PRESSURE (kpa)	100
TEST PRESSURE (kpa)	76
DESIGN TEMPERATURE (°C)	105 Plates
NUMBER OF PLATES	1 / 1
NUMBER OF PASSES (HS/CS)	Threaded NPT
CONNECTIONS TYPE	45,84
HEAT TRANSFER AREA (m²)	200
PORTS DIAMETER (mm)	45
CHEVRON ANGLE (deg)	

N.B: All dimensions are in (mm)

PLATE HEAT EXCHANGER MATERIAL LIST	
PART NAME	MATERIAL
FIXED COVER	Carbon Steel
MOVABLE COVER	Carbon Steel
CARRYING BAR	SS AISI 316
GUIDE BAR	Mild Steel
PLATES	SMO-254
GASKETS	Viton
CONNECTION TYPE	Threaded-NPT

Central Ostrorobothnia University of Applied Sciences				
Made By	Checked By	Date	Drawing No	REV
Uwe Eguenu		1/5/2011	1	