

**ANALYSIS OF METHODOLOGIES OF THE RECONSTRUCTION OF  
BUILDINGS ON THE EXAMPLE OF MASONRY STRUCTURES**



Bachelor's thesis

Visamäki, Degree Programme in Construction Engineering

Spring 2018

Vishniakov Pavel

Degree Programme in Construction Engineering  
Visamäki

---

<b>Author</b>	Vishniakov Pavel	<b>Year</b> 2018
<b>Subject</b>	Analysis of methodologies to the reconstruction of buildings on the example of masonry structures	
<b>Supervisor(s)</b>	Jari Komsu	

---

ABSTRACT

The purpose of Bachelor's thesis was to analyse the process of carrying out the reconstruction project. Another goal was to systematize the most optimal methods with the issuance of recommendations for its consummation. In addition, it was important to understand how determination of the actual technical condition of load-bearing structures and conception of its behaviour could influence on justifying of selected constructive solutions. Masonry structures were as an example for this matter.

The thesis structure is divided into two parts. The theoretical part of this thesis was assembled from technical literature and it was filled in completely with personal reflection and work experience in conjunction with scientific articles. The practical part was based on the available construction design documents of the car wash's reconstruction project in the city of Moscow. This part includes calculations, plan, elevations and assembly drawings. This thesis was commissioned by "Carel Group" Ltd.

The results of the thesis demonstrate the progress of implementation of the reconstruction project with explanation of the reasons for carrying out certain measures to solve both constructive and economic issues. It contains ideas of improving the leading of reconstruction project. Besides that, it include guidance on exposure and elimination of masonry problems, as the structural unit, which was selected as the object of analysis.

The thesis primarily can be useful in acquaintance with a direction of the construction, such as the reconstruction of buildings, since it contains all information necessary to know at the initial stage.

**Keywords** Renovation, reconstruction, masonry

**Pages** 66 p. + appendices 4 p.

# CONTENTS

1	INTRODUCTION .....	1
2	RECONSTRUCTION OF BUILDINGS AND STRUCTURES .....	2
2.1	Demands of the city in the reconstruction of buildings .....	2
2.2	Goals and objectives of reconstruction .....	3
2.3	Investment cycle of the project .....	5
2.3.1	Pre-project stage .....	5
2.3.2	Assessment of the technical condition of buildings and structures .....	6
2.3.3	Drafting reconstruction project.....	11
2.3.4	Realization of the reconstruction project .....	12
2.3.5	Commissioning works.....	13
2.3.6	After-project stage .....	13
2.4	Inference .....	15
3	REINFORCED AND UNREINFORCED MASONRY STRUCTURES .....	16
3.1	Inspection of reinforced masonry structures .....	16
3.1.1	Features of work and structural failures .....	16
3.1.2	Determination of the technical condition .....	21
3.2	Maintenance of reinforced masonry structures.....	25
3.2.1	Traditional methods of reinforcement and recovery.....	25
3.2.2	Modern technology of reinforcement .....	32
3.3	Inference .....	34
4	CONSIDERATION OF RECONSTRUCTION METHODS ON THE EXAMPLE OF A WORKING PROJECT .....	35
4.1	Information about the object of reconstruction.....	35
4.2	Physical and technical parameters of structural elements.....	37
4.3	Load summary .....	42
4.4	Calculation of the wall strengthening by reinforced concrete casing .....	44
4.4.1	Actual bearing capacity of the wall .....	45
4.4.2	Specification of the strengthening .....	49
4.5	Calculation of the column strengthening by pre-stressed struts .....	51
4.5.1	Actual bearing capacity of the column.....	51
4.5.2	Specification of the strengthening .....	53
5	CONCLUSION .....	57
	REFERENCES.....	58

## Appendices

Appendix 1 Roof sectional elevation

Appendix 2 Cross-section drawings

Appendix 3 Design resistance of the masonry to compression

Appendix 4 Elastic response of the masonry

## 1 INTRODUCTION

Reconstruction of buildings is one of the directions of major construction, the main tasks of which are the reorganization of the facility, improvement of its quality and operation conditions [Gorse, Johnston & Pritchard 2005, 342; Dictionary of construction n.d]. From the definition, it is clear that this type of work involves working with old buildings whose architectural-planning and technical solutions are outdated and cannot meet the requirements for exploited buildings. Hence, there is a need for skilful integration and association of modern solutions. Therefore, this leads to the questions of what it is necessary to know for the successful implementation of the conceived project, in which cases it is expedient to conduct, what to beware of and what to guide by during the project.

There are no universal rules describing on how reconstruction work should be carried out. In general, many companies make decisions based only on their own experience, which often leads to errors on certain stage. Especially companies, which are just beginning work in this area, come across with that. In an attempt to prevent the rise of such hazardous situations, typical reconstruction approaches were supplemented by personal experience and relevant scientific literature to make this thesis a comprehensible construction guide.

The example of masonry reconstruction at the construction site of the early 20th century were chosen, as an object for detailed consideration and demonstration of the application of the collected data. The reason for this choice was the massive use of structures of this type [Stewart 2005] and the specificity of the structure under load and under the influence of external factors. And also the fact that the work at this facility is the illustrated summary of how it is important to timely solve the tasks and what role the algorithm, the way of approach and understanding of all aspects play in the design and implementation of the reconstruction plan.

## 2 RECONSTRUCTION OF BUILDINGS AND STRUCTURES

Modernization of technological processes, installation of new equipment, expansion of production, renewal of physically obsolete building structures or uninhabitable dwellings, changes in hydrological conditions of soils and many other things require measures to give construction structures properties that meet the requirements of new operating conditions and take into account both social objectives and economic effectiveness of its implementation.

### 2.1 Demands of the city in the reconstruction of buildings

Reconstruction of any building or structure involves solving a number of issues related to not only a particular building, manufacture or district, but to the entire city as a whole. It entails the need for a careful and cautious approach to the existing construction.

A number of trends observed in global practice can cause the city's demand for reconstruction [Shikhov 2016, 9; Ciblac & Morel 2014, 5; Travin 2013, 8]. First, the development of market relations in the world and, as a consequence, the decrease in the proportion of the population engaged in manual labour and the growth in the number of people working in the service sector. Such evolution increases the attractiveness of public buildings located in the central or historic districts of cities, whose age can reach more than 100 years. (Fig. 1)



Figure 1. Moscow building age map: purple – building before 1917 [Building Age Maps 2013]

The problem of reconstruction of that kind categories building is the significant costs required for the organization of such events. Therefore, some buildings are transferred to commercial structures, which are

responsible for the preservation, reconstruction and adaptation of buildings for new social functions (office premises, museums, exhibition halls, etc.). With the proper use of buildings, this approach allows to extend the service life of buildings and to release public funds for the reconstruction of other public buildings.

Another possible solution to preserve the existing building can be a complex reconstruction, which is based on the reconstruction of public buildings and some parts of residential buildings, which are subsequently reorganized for new public functions (catering, shops for various purposes, workshops, etc.). This direction of reconstruction allows transforming whole streets or districts of the city, giving them a new content and a single architectural expressiveness.

Secondly, the discrepancy of manufacture with today's requirements and non-competitiveness of their products lead to the need either to modernize production in accordance with modern standards and practices or to transform them urgently to other objects of the urban environment. Moreover, the transformation of manufacture allows not only to reduce the cost of developing urban areas, but also to obtain new social facilities (sports complexes, exhibition pavilions, shops, etc.), which are usually in scarce in microdistricts.

Thus, it can be concluded, that, firstly, the process of reconstruction of buildings is inconceivable without the organization of a modern level of landscaping, cultural and public services for the population. Secondly, that the reconstruction should be based on a long-term town-planning strategy, which is a systemic task with the fullest possible inclusion of social, economic and town-planning criteria.

## 2.2 Goals and objectives of reconstruction

From the previous chapter it is clear that the development of the city requires the regular adaptation of the building to the changing requirements that ensure the safety and comfort of the population.

The list of factors, that mainly reflect the requirements for construction, and which affect the implementation of reconstruction activities, includes [Shikhov 2016, 10; Zolotozubov & Bezgodov 2014, 14]:

- Architectural and historical (the presence of historical and cultural monuments, the existing historical appearance of the building, etc.);
- Sanitary and hygienic (site development density, noise regime, aeration, insolation, etc.);
- Topographical (slopes, green plantings, landscaped areas, etc.);
- Socio-demographic (the presence of social services, recreation parks, places of social and administrative assignments etc.);
- Influence and impact of the immediate environment (the presence of manufacturing plant, production facilities, motorways, park areas, etc.).

Analysis of the factors mentioned above influences the relevance of reconstruction or on the choice of a course and approach to the implementation of reconstruction works, which can be divided into 4 types: conservation, restoration, transformation and complete reconstruction [Travin 2013, 8].

1. The form of conservation is used in those cases when it is necessary to restore the lost and dilapidated elements of buildings that violate the integrity of the composition, without affecting the most valuable fragments of the urban environment.
2. The restoration is practiced when it is necessary to preserve the existing historical and architectural heritage with a limited inclusion of new elements that make up for the loss of previously existing ones.
3. The transformation method is used mainly in areas with a preserved environment of historical development and is aimed at filling the loss of building elements by erecting new buildings whose shapes and sizes are consistent with the historical environment.
4. The complete reconstruction is carried out on low-value urban development with preservation of the basic concepts of its planning structure (streets, driveways and squares).

After identifying with the course and approach to a specific existing housing, there is a need for detailed consideration of each component and building separately. For the reason that reconstruction of housing depends on the demands of the city, while reconstruction of individual building depends only on its characteristic. Therefore, it is necessary to solve the planning, constructive and engineering tasks, the volume of which is determined during the stage of assessment of the technical condition by the physical and moral deterioration of buildings [Guchkin 2001, 6; Shikhov 2016,10].

1. Under physical deterioration, it is comprehended the reduction in the building's structural elements of the initial technical properties during operation (strength, durability, insulating properties, etc.).
2. Under moral depreciation, it is comprehended the discrepancy of a unit of a structure (apartment, separate room, etc.) or the whole building with changed norms or standards, which leads to a decrease in the consumption value of the building.

Based on the conclusions about the physical and moral condition of the building units, structural elements and engineering systems, the type of technical measures for the reconstruction of the building is selected [Gorse, Johnston & Pritchard 2005; Zolotozubov & Bezhgodov 2014, 20]:

1. Renovation – is a complex of repair and construction works to eliminate physical deterioration through the strengthening of the structure, engineering support systems and improving the performance of the facility without changing the planning or architectural solutions.
2. Restoration – is an elimination of moral depreciation by improving the planning, creation of living environment, replacement or enhancement



of equipment with new technical devices without changing the external dimensions and functional purpose of the object of modernization.

3. Reconstruction - is the most complex form of building transformation. It connected with the change of technical and economic indicators or functional purpose of the building and also with changing of its volume and appearance in order to improve operating conditions, quality of service and increase the scope of services.

This classification of approaches and types of reconstruction work is necessary to determine the list of activities to be implemented more accurately and to optimize them later on. Consequently, it entails a decrease in capital expenditure, due to a reduction in the time for plan accomplishment and consumption of materials. Besides, it's necessary to correct removal and introduction of renewed buildings in the infrastructure of the city.

### 2.3 Investment cycle of the project

The investment cycle of the reconstruction project for a residential building or manufacture includes stages (Fig. 2) similar to the project of erecting a new structure, but differ significantly in the implementation method and the progress of each of them.

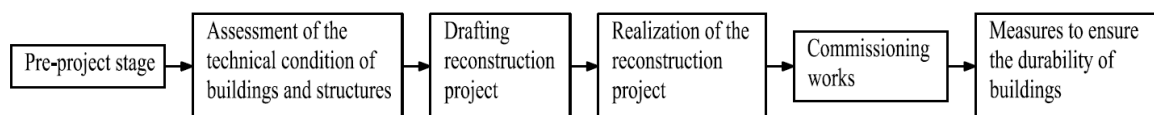

Figure 2. Investment cycle of the reconstruction project

#### 2.3.1 Pre-project stage

The pre-project stage is based on acquaintance with the task set and the general wishes of the customer, if there are any. Further, it provides a basis for solving the problems of ensuring the safety and reliability of the reconstructed facility and the effectiveness of investment. Moreover, the last, as a rule, is most difficult to implement, since the foundation of real estate management activity, regardless of its functional purpose, is based on obtaining a specific favourable result, whether it is increasing incomes or cutting costs, attracting new investments or the audience, etc.

In general, the real estate management sphere is marked by instability, high level of risk and uncertainty. Firstly, it is connected with the features of real estate, such as a long production cycle, significant investment and cost, the constant quality improvement and modernization. Secondly, the dependence of the result on external factors such as market conditions.

Another possible error of the initial stage can be the fact that the cost of the project is incurred the cost formed only at the design and construction stage. As the working practice shows, calculation is made without taking

into account subsequent operational costs, which are usually much higher than construction costs.

Since the economic component is one of the most important in construction work of any kind, it can be concluded, that it is necessary to take into account the known difficulties, to predict the emergence of new ones due to attendant factors, to anticipate risks and to reduce them to the minimum level during the process of project management.

### 2.3.2 Assessment of the technical condition of buildings and structures

The assessment of the condition of buildings corresponds to the research of the production environment and the technical condition of structural and architectural elements of buildings, without which reconstruction is unacceptable, since at this stage a wide complex of issues is being solved [Shagin 1991, 28-37; Travin 2013, 73-87].

The research of reconstructed objects is an independent area of construction activity, the main purpose of which is to create in buildings normal living and working conditions for people, to ensure the operational reliability of buildings and the further process of reconstruction and, overall, to determine the expediency of its carrying out. To generalize, it could be divided into the assessing of architectural and planning solutions state and technical condition of the building's construction. If the first is based on the prospects of its further use and the reduction of moral depreciation to a minimum, then in the case of the second it is necessary to identify and eliminate the dilapidation of the building, which corresponds to the stage of the survey. The survey is the whole complex of measures for determining and assessing the actual values of the monitored parameters characterizing the technical condition of the survey objects, as well as the possibilities for their subsequent operation or the need for their reconstruction. The following reasons could be the base for the survey [Shikhov 2016, 25; SP 13-102-2003, 4]:

- Presence of defects and damages of structures that can reduce strength and deformation characteristics and worsen the operational condition of the building;
- Increase in operational loads and effects on structures during re-planning, modernization and increasing of the storeys number of the building;
- Identification of deviations from the project, reducing the load-bearing capacity and performance characteristics of structures;
- Lack of engineering design and executive documentation;
- Change in the functional purpose of buildings and structures;
- Resumption of the interrupted construction in the absence of conservation;
- Deformation of soil bases;
- Necessity of monitoring and assessing the condition of structures of buildings located near the construction sites;

- Necessity of monitoring and assessing the condition of building structures exposed to fire, natural disasters or man-made accidents;
- Necessity of determining the suitability of industrial and public buildings for normal operation, as well as residential buildings for living

The inspection of the technical condition of building structures is usually carried out in four sequenced-related stages: preparation for the survey, preliminary (visual), detailed survey and estimating of technical conclusions.

#### 1. Preparation for the survey

The survey program is compiled on engineering design documentation, including historical and archival data, working drawings and their explanatory materials. The study of design and technical documentation is necessary to determine the features of the structures and to identify the changes and discrepancies introduced earlier with real constructive schemes, which subsequently allows more accurately designate the survey program.

#### 2. Preliminary (visual) survey

The preliminary survey is carried out for the preliminary assessment of the technical condition of building structures by external characteristics and for determining the need for a detailed instrumental survey. In addition, a general inspection of the building by specialists may have preconditions for preventing the occurrence of dangerous and breakdown incident as a result of building's damage or collapse.

The basis of the preliminary survey is a visual inspection of a building structure and individual elements using measuring instruments and tools (binoculars, cameras, roulettes, callipers, probes, etc.) [Shikhov 2016, 28; Shagin 1991, 27]. At the beginning of inspection, regardless of the materials of the building, measurement work are performed, the purpose of which is to clarify the actual geometric parameters of building structures. The list of works includes:

- Specification of the centring axes of the structure and its overall dimensions;
- Measurement of basic geometric parameters of load-bearing structures;
- Determination and verification of the actual sizes of cross-sections of structures and their elements;
- Determination and verification of the shapes and sizes of nodes of butt joints of elements and their support parts;
- Measurement of deformations of building structures.

The result of measurements is a plan with the actual arrangement of structures, building's sections, drawings of bearing structures working sections and interface node.

Based on the results of the visual inspection, a preliminary assessment of the technical condition of the building structures is made, which is determined by the degree of damage and by the characteristic features of the defects. A fixed picture of defects and damages (Table 1) may form the basis to identify the causes of their origin and be sufficient to assess the condition of the structures and draw up conclusions.

Table 1. Example of the sheet of defects

Index number	Type of the defect	Localization and description of the defect	Notation
--------------	--------------------	--	----------

For these purposes, a number of recommendations have been developed for an approximate evaluation of the reliability of the structures, engineering systems, and buildings in general [Dobromislov 2001, 10-14; Grozdov 2005]. Such recommendations minimize the need to use special equipment and establish the category of technical condition of buildings, possible periods of operation without modification, period of the refinery restoration project, as well as the need for more accurate methods for determining the reliability of structures.

However, if the results of the preliminary survey are insufficient to solve the tasks, then a detailed (instrumental) survey is carried out.

### 3. Detailed (instrumental) survey

The detailed survey also contains the measurement work, as well as the sampling for laboratory studies, engineering and geological surveys, geodetic works, structural tests, analysis of the causes of defects and damages in structures.

The detailed survey, depending on the tasks assigned, the availability and completeness of the design and technical documentation, the nature of defects and damages may be continuous (complete) or selective [Shagin 1991, 28; SP 13-102-2003].

The continuous survey is conducted when:

- Lack of project documentation;
- Detecting of defects of structures that reduce their load-bearing capacity;
- Reconstruction of the building with increasing loads (including storeys);
- Resuming of construction, interrupted for more than three years without conservation measures;
- Unequal properties of materials in the same type of construction, changes in operating conditions under the influence of an aggressive environment or circumstances such as technogenic processes, etc.

The selective survey is carried out when:

- Inspection of individual structures;
- Inability of conducting a continuous survey in potentially dangerous and inaccessible places.

The main methods for conducting a detailed survey of structural elements of the building, depending on the material and location of the elements, can be attributed:

- Acoustic. It is used to determine the sound permeability of wall and floor materials;
- Ultrasonic. It is one of the special cases of the previous method used to determine hidden defects in materials and structures. It is used to determine the strength of concrete, the opening of cracks in masonry or concrete, the analysis of the thickness of metal structures and the quality of welds;
- Electromagnetic. It is used to study the structure, the thickness of hidden defects in foundations, pipelines, structures and the presence of landslide processes in soils;
- Radiometric. It is carried out to determine the density of stone, concrete and various bulk materials.
- Neutron. It is used to determine the density or humidity of concrete, stone, brick;
- Electrooptical. Used to determine the vibration parameters of structures.
- Squeezing and break with shear. Used to calculate the strength of concrete.
- Method of plastic deformation. Used to determine the deformability and strength of materials;
- Pneumatic. Used to determine air permeability;
- Thermal imaging. It is used to determine the level of thermal protection of the building, zones of abnormal overheating of electrical appliances, for diagnostics of water supply and heating systems;
- Theodolite survey, levelling and photogrammetry. It is used to determine the foundation draft, the volume deformation of a structure.

Based on the results of a detailed survey, complete picture of the destruction of the building, identifying the causes of this destruction, can be obtained as well as the most acceptable way to solve problems to strengthen the structural elements of the building can be determined.

#### 4. Preparation of technical conclusions based on the results of the survey and results of the survey

The criterion for assessing the technical condition of a building as a whole and its structural elements and engineering equipment is physical depreciation. The calculation methods can greatly differ and depend on the constructive and economic factors [Smorchkov, Kereb, Orlov, Baranovsky 2012; Sokolov 2011]. However, they come down to determining the technical condition of the building, which is contingently divided into 5 categories presented in Table 2, in depends on the available damage and reliability.

Table 2. Estimation of the building's condition from general physical depreciation

Building condition	Physical deterioration, %
Good	0-20
Satisfactory	21-40
Not completely satisfactory	41-60
Unsatisfactory	61-80
Unsuitable (emergency)	81 and above

As a result of the survey, the actual design scheme of the building as a whole and its individual structural elements, which entering a single building system, is revealed. Furthermore, such system is affected by the redistribution of loads due to the increase in time of the building's frame rigidity, the emergence of unified sites and the inclusion of partitions in the work of overlaps and so on. Therefore, Quantification of these factors is a serious task, the solution of which goes beyond the normative and reference documents used to calculate the construction of new building.

On this basis, verification calculations of structures and nodes are performed, taking into account the actual design schemes and loads, as well as the detected structural defects. The purpose of verification calculations is to establish the correspondence of the actual load-bearing capacity of the structures to the present requirements.

The overall result of the whole complex of survey works is the final document, in which reported by results of the survey:

- Assembly, detail, plan and elevations drawings;
- Scheme of defects and damages with photographs and instructions of the most characteristic of them;
- Values of all controlled characteristics, the definition of which was foreseen by the terms of reference or the survey program;
- Results of verification calculations, if they were envisaged by the survey program;
- Report on the technical condition with the information provided by the project and executive documentation.
- Recommendations and instructions for ensuring the destructive values of the strength of structures with a list and sequence of work.

The conclusion, presented in final documents, bases on the carried out survey of load-bearing structures, verification calculations and analysis of their results. It contains the category of technical condition of the structures, the remaining service life of the building, possible options and ways of reconstruction and reinforcement of structural elements and a decision of their further operation. This information is enough to start making a whole plan of reconstruction.

### 2.3.3 Drafting reconstruction project

Designing the reconstruction of buildings and structures is a fundamental moment in the implementation of any construction and repair work at a particular facility. The reconstruction project is a package of documents prepared and passed through the approval process, which details all changes made to the building structure, the use of resources and materials, construction and installation works, as well as the way of their implementation and the scheme of linkages. The design process involves several basic steps:

- Based on the results of the survey, an assessment of the feasibility of the work, their scope and the primary measures for their implementation.
- Preparation of design estimates, sketches, calculations on the operation for the implementation of all stages of the upcoming construction and repair work.
- Coordination of the project in public authorities, services and instances.

After analyses of current condition of structure the method of repair and reinforcement of building structures and their individual elements could be selected. The selection of the execution work depend on the following factors:

- Material of the structure;
- Presence of defects, the degree of damage to the structure;
- Location of the structure;
- Impact on the work of an administrative or industrial building;
- Influence on people's living conditions;
- Financial feasibility of work.
- Personal wishes of the customer

On this basis, calculations are made in accordance with the current construction norms and with respect to changes in the existing loads, volume-planning decisions, operating conditions and defects detected during the surveys. It is also necessary to remember that irrespective of the chosen method the reconstruction project should comply with the requirements imposed on the building [Guchkin 2001, 96-110; VSN 53-86 1988]:

- Be reliable, i.e. perform the functions assigned to them under certain operating conditions for a given time, while maintaining the values of their main parameters within the specified limits;
- Be comfortable and safe to use, i.e. have a rational layout of building spaces;
- Be convenient and simple in maintenance and repair, i.e. to allow it to be carried out on as many sites as possible, to have convenient approaches to structures, inputs of engineering networks without dismantling for inspections and maintenance with extremely low costs for auxiliary operations;

- Be economical in the process of operation, which is achieved by the use of materials and structures with a longer service life;
- Have an external architectural appearance that is appropriate for their purpose and location in the building, as well as enjoyable for viewing.

The next step is the development of design estimates for the reconstructed facility, which is based on the prepared and coordinated set of works, includes:

- Architectural-planning and constructive solution;
- Solutions for engineering equipment;
- Projects for the organization of construction and technical operation of the building;
- Estimate documents and general explanatory note.

From all the above it can be concluded that the complex of ongoing and encompassed activities is developed individually for each specific building and reconstruction site. It provides the implementation of the tasks stipulated by the reconstruction project and the choice of technical measures, which are based on the results of the survey of physical and moral quality of the building.

#### 2.3.4 Realization of the reconstruction project

The implementation of the reconstruction project includes architectural, planning, assembly and construction works, in particular the installation of technological equipment, according to the developed plan for the introduction and implementation of the reconstruction project.

An example of the work at this stage can be the reconstruction of an operating manufacture. Serious difficulties arise in connection with the need to ensure a minimum shutdown of manufacture. The monetary losses due to the decrease in output are comparable, and in some cases significantly exceed the volume of capital investments for construction and installation works for reconstruction or technical re-equipment. Because of that, the technological sequence of the reconstruction work has to be coordinated with the main production activities of the factory. The most effective is the organization of reconstruction by the nodal method. The factory is divided into nodes, in other words constructively detached parts, within which it is possible to independently conduct construction, installation and adjustment of technological equipment and to hand over this completed part to the operation service. In the project of the organization of construction the schemes for breaking up the manufacture into nodes, schemes for technological interconnection of these nodes, and the sequence of their input are given. During the work on a node, the continuity of the main technological process of the manufacture is provided by the following activities:

- Use of backup equipment;
- Use of reserve sites in the manufacture;
- Transition to temporary technological scheme of work.



It may be noted that the reconstruction work usually has to be conducted in cramped conditions, when the choice of construction technology and installation work is very limited. Nevertheless, the specific nature of the reconstruction consists not only of additional organizational and technological problems. There are factors that, on the contrary, simplify the course of work, as labours could avail of own building's utilities system, or various lifting mechanisms and even a transport, if it presents.

Hence it follows of the proper compilation of the list of works at the design stage, which will ensure performance of work in the shortest possible time, with a minimum reduction in output; the lack of interference with the city's infrastructure with the help of the competent use of the internal and adjacent territory.

### 2.3.5 Commissioning works

Commissioning at the completion of reconstruction is almost the same as the work carried out in newly built structures. This type of work is of a technical nature and is intended for tuning of mounted equipment, as well as checking all systems for operability, continuity, absence of failures and defects. As a rule, commissioning works includes:

- Checking of the tightness of the utilities system;
- Checking of the elements correct installation;
- Trial run of the equipment;
- Adjustment of work in different modes;
- Conducting instrumental control of work parameters.

In many respects, the duration of further operation of the facility depends on how well commissioned works have been carried out.

### 2.3.6 After-project stage

After-project stage is intended measures to ensure the durability of buildings. Since the important factor, that influences the final cost and general expediency of the work being done, is the proper operation of the construction project after the handover. In the package of measures to increase the operational period, it is possible to include:

#### 1. Overload protection

To protect building structures from overloading do not allow:

- Installation, suspension and fastening of process equipment, various types of internal transport and transfer devices, which is not provided by the project;
- Exceeding of the maximum load on the floors, inter-floor ceilings, mezzanines and platforms in all production, storage and other purposes;
- Exceeding of the maximum load on the building structures due to temporary devices necessary for the production of construction and installation works in existing workshops.

## 2. Protection against mechanical damage

To protect building structures against mechanical damage, it is recommended to avoid:

- Impact from careless or negligent unloading of materials, throwing parts and heavy objects, moving equipment, etc.;
- Impact and other mechanical damages during the manufacture of construction and installation works (repairs, renovations, re-planning of equipment, etc.).

## 3. Protection from high temperatures

To protect building structures from high production temperatures, it is necessary to exclude:

- Hit of liquid metal on building structures, contact with heated parts and other effects of high temperatures;
- Influence on building structures of radiant energy due to malfunction of technological equipment or underestimation of such impact.

## 4. Protection from aggressive influences of the production environment

Preventive measures to protect against acids, alkalis, salts, dust and gases from chemicals involves:

- Proper organization and management of production processes, maintenance of engineering systems in good condition, avoiding leakage, spilling and evaporation of chemical products;
- Special measures of protection the structures against corrosion, to eliminate the corrosive effects of chemicals on building structures.

## 5. Maintenance of the design temperature and humidity regime

Preventive measures to maintain temperature and humidity regime in buildings involves ensuring the integrity of the enclosing structures, maintaining the appropriate indoor temperature and adequate ventilation.

## 6. Protection from the effects of climatic factors

To protect the building structure from the harmful effects of climatic factors, it is necessary to carry out the following measures:

- To keep in good condition and to timely renew the protective covering layers of roofs, plasters, coatings, varnish-and-paint and others;
- To keep in working order all devices for tapping of atmospheric and thawed water before the onset of frost and before the spring snowmelt, and the detected faults are immediately eliminated.

Constant monitoring of the condition of buildings and their structural elements is necessary for the timely detection and elimination of minor damages and defects, arising during operation or allowed during the construction of facilities, in order to prevent their subsequent development and, as a result, large destruction of structures.

## 2.4 Inference

From this chapter it is clear that, a huge number of non-standard tasks, the correct decision of which affect how optimal the subsequent operation of the building will be, always accompanies the reconstruction of buildings. Responsibility in the first place is assigned to the engineer, who must go beyond the official framework. This involves thinking over the economic component of the project, with respect to not only the cost of materials, but also to the cost of implementing the conceived design solutions. As an engineer should be able to draw the right conclusions about the state of the structure, which requires deep knowledge of the behaviour of building materials and structural elements. As well as perhaps the most necessary is not only the care of correcting the defects presented today, but also a clear understanding of the prospects for operating the reconstructed site, with a view to ensure the convenience of use and to prevent the formation of new defects due to design errors.

### 3 REINFORCED AND UNREINFORCED MASONRY STRUCTURES

Constructions of masonry are the one of the oldest types of building structures, which were used to erect buildings of different purposes and are still in use due to the durability, fire resistance, as well as the possibility of giving buildings a variety of architectural forms and the development of industry of these materials. However, suchlike structures made from other building materials, masonry structures are subject to the destructive effect of external and internal factors, whose elimination is a systemic task that usually goes beyond working with a specific material.

#### 3.1 Inspection of reinforced masonry structures

##### 3.1.1 Features of work and structural failures

Under the masonry understand the structure of heterogeneous elastoplastic bodies, mainly made of natural or artificial stones (bricks, blocks) and connected together by a mortar, adhesive cement or paste, which perceives loads of its own weight and loads applied by the other structural elements, and also performs heat, sound insulation and other functions [Gorse, Johnston & Pritchard 2005, 264; Aita, Pedemonte & Williams 2015, 6]. It is possible to determine the following specificity of masonry work, proceeding from these design features. During compression, the load is distributed non-uniformly due to local roughness and different density of individual parts of the hardened mortar, as a result of which the stones are undergo not only to local compression, but also to eccentric compression, shear, bending and tensile.

In general, the work of the masonry under compression, depending on the magnitude of the acting stresses, can be divided into four characteristic stages [Kabantsev 2016; Grozdov 2005, 36], shown in Fig. 3.

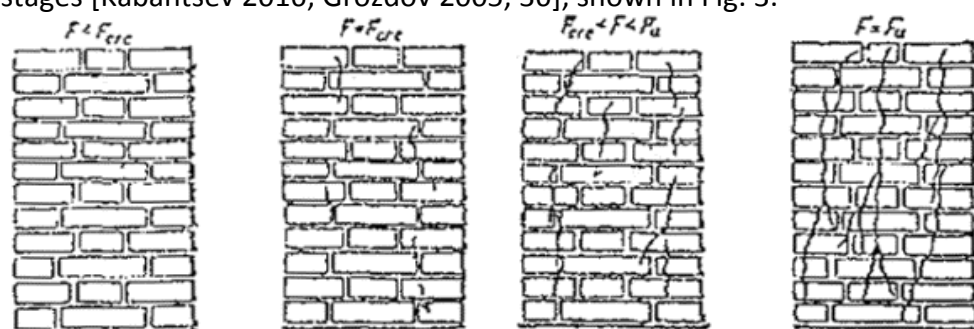

Figure 3. Stages of work of the masonry at compression  $F$  - stress in the masonry;  $F_{crc}$  - load, in which cracks are formed;  $F_u$  – ultimate load

1. The first stage with  $F < F_{crc}$  – The formation of cracks does not occur, the condition of structures is normal.
2. The second stage with  $F = F_{crc}$  – The appearance of individual vertical cracks in bricks or stones; The first cracks in most cases are formed under and over the vertical bed joint, which is caused by the bending and

shear fracture of the stone, as well as by the concentration of tensile stresses above these bed join. The condition of structures is satisfactory.

3. The third stage with  $F_{crc} < F < F_u$  – The development of local vertical cracks and the occurrence of new vertical cracks. Such combination gradually divides the masonry into separate, independently working vertical elements, each of which appears both under conditions of stress development and eccentric compression. Even under the conditions of growth cessation of the load applied to the masonry, deformations continue to progress with time. Therefore, the third stage of the stressed state of the masonry requires the immediate unloading of this masonry, followed by its reinforcement or replacement, with the observance of the necessary safety measures with appropriate technical supervision. The condition of structures is unsatisfactory.
4. The fourth stage with  $F = F_u$  – The development of deformations leads to disintegration of the masonry into separate columns without increasing the load. Columns are destroyed by the appearance of eccentricity in the section, buckling force and crumbling of individual stones. The condition of structures is pre-emergency or emergency.

Each stage can be correlated with one or another category of technical condition. However, this knowledge is not enough to assess the level of destruction of the masonry completely, because their appearance can be caused by different factors, the presence and influence of which is established at the survey stage.

- Constructive

The analysis of the conducted tests [Stukach & Sharapov 2016; Zigler & Witzany 2016] of laying with different physical and mechanical properties and parameters shows that it is impossible to fully use the stone's resistance to compression. As shown in Figure 4, the strength of the masonry has a certain limit, which is always less than the ultimate strength of a single element.

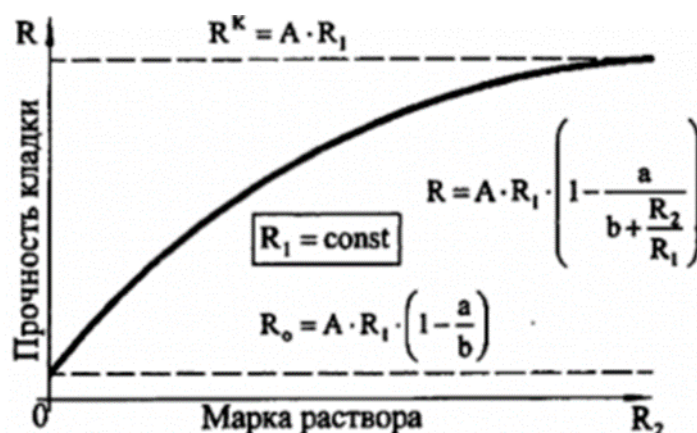

Figure 4. Dependence of the masonry's strength on the mortar grade

This limit of strength in turn depends not only on the physical properties of the stone, but also on violations of its geometry. For

example, with a reduction of height, the cross-sectional area and the moment of inertia decrease too. As it appears from the mechanics of materials, it is possible to observe a decrease in stone resistance to shear and bending. In this case, the brand of the applied solution becomes more significant (Fig. 5).

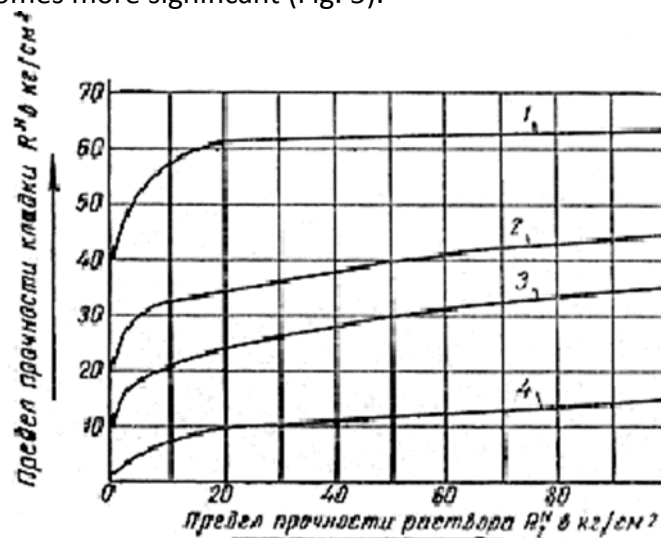

Figure 5. Dependence of the masonry's strength on the strength of the solution for different materials

From the above graph it is seen that the smaller the cross-section and the strength of the stone, the more significant the difference between the maximum and the minimum value of the strength of the masonry. Consequently, the fluctuation of these quantities directly affects the final properties of the masonry.

- Effects of moisture

The presence of an increased humidity regime or the influence of an unfavourable environment due to atmospheric precipitation, groundwater, condensate, etc. has a ruinous effect on the bearing capacity of the structure. The formation of crystals of certain types of salts, as a result of the water transportation through the microspores of the structure, can lead to gradual destruction and deterioration of heat engineering properties, and often to the formation of mould and fungal lesions [Groz dov 2005, 47].

- Temperature

The erection of masonry with violation of the temperature regime strongly affects the ultimate strength. This is connected mainly with the physical and mechanical properties of the solution used. Therefore, at a very high temperature, it is possible to dehydrate the solution with a dry brick, which takes away all the moisture and leads to deterioration in the adhesion between the materials and, in particular, to a complete stratification [Smoljanovic 2017; Guchkin 2001, 14].

In the case of a low temperature, the solution does not have time to gain a minimum stiffness, without the usage of special admixtures,

which entails uneven settling and masonry damage when the temperature rises.

- **Dynamic**  
Deformation of the foundation [Kabantsev 2016; Peñal 2004], as a result of unbalanced changes in the loading of different parts of the building, as well as changes in ground conditions, their washing out and subsidence, can cause deformation of the structure and redistribution of forces. Such a sharp increase in load, different from the projected one, directly affects the formation and development of cracks.
- **Violation of the production's rules**  
To facilitate the work of the mason, resort to increasing the mobility of the mortar, as this requires less effort to erect [Guchkin 2001, 45]. This is achieved by increasing the water balance of the solution, or by adding plasticizers. In the first case, excess water is absorbed into the masonry, which may subsequently lead to problems associated with moisture. In the second case, a gain in mobility leads to an increase in deformability and density, which inevitably causes discrepancies in the thickness of the bed joint with a normalized one. On the one hand, such defects improve the fillability of roughness and soften local tension, working as a cushion. However, this leads to the rise of efforts of stretching brick, the mechanism of which is discussed below. Accordingly, depending on which of the given effects is stronger, the strength of the masonry may increase or decrease.

In addition, specific factors take place at the stage of erection. However, such factors almost do not lend themselves to detection, and therefore cannot serve as a justification for choosing the method of reconstruction.

From the analysis of the impact of the factors above on the integrity of the masonry, as well as on its ability to accept the load, the several conclusions about the reasons for this work come out.

The first and the main reason is related to the defects of the solution, which leads to the formation of areas that differ from each other in strength and deformation properties [Sarhat 2016]. During compression, the stress concentration occurs in areas with greater rigidity. Therefore, individual elements of the masonry are subjected to non-uniform distributed and concentrated loads on one side and to the reaction of the support to the other, which in turn also has a chaotic and uneven effect (Fig. 6). Because of the imperfections of the force distribution, transverse forces, bending moments and regions with local compression arise in such element.

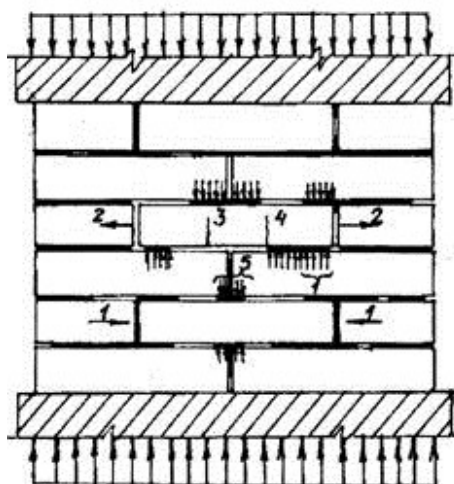

Figure 6. Stress state of the stone in the masonry: 1 – compression; 2 – tensile; 3 – bending; 4 – shear fracture; 5 – local compression

However, even in the absence of defects in the masonry and mortar, which is not implemented under the existing methods of erection, the formation of a complex stress state is inevitable. This is caused by the presence of longitudinal and transverse deformations, which directly depend on the rigidity of the material. An interesting picture is observed in the combined action of materials with different rigidity during compression, since they are forced to have the same transverse deformation (deflection) in the zone of their contact, due to the presence of friction between them. When a load is applied, the material with higher stiffness is suppressed by deformation of the material with a lower stiffness, which in turn acts on the contrary. From this it follows, that the conditions of combined action leads to the appearance of tensile stresses in one and compression in another (Fig. 4, 7). It sums up with the tensile stress arising through the natural deformation under the action of the load, and overcoming the ultimate resistance of the stone to tensile, resulting in the formation of the first cracks in the stone.

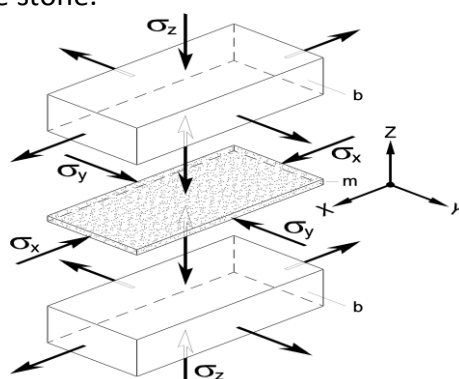

Figure 7. Example of interaction of a stone with a solution

The second reason for this kind of masonry work is the presence of perpend and holes in hollow stones. There is a concentration of stresses near these areas, which entails the uniformity and continuity disturbance of the masonry and, consequently, the first cracks in the mortar. However, it does not lead to a reduction in the strength of the masonry itself, but



because of the non-uniformly concentration of tensile and compressive stresses, the main reasons, caused by structural defects, begin to appear.

Thus, it can be concluded that the greater the influence of the factors destroying the structure, the more it is possible to observe the appearance of the structural features when the load is applied. Therefore, a clear understanding of the work of the material, its behaviour and weaknesses gives a huge advantage in detecting defects, verifying the calculation of load capacity and determining the most optimal method of amplification.

### 3.1.2 Determination of the technical condition

The state of reinforced and unreinforced masonry structures can be assessed, as for most other building structures, by external feature, for identifying emergency areas, and with the use of special equipment to reveal hidden structural features. Several universal recommendations have been developed for this purpose [Guchkin 2001, 96-99; Dobromislov 2001, 13-72; Grozdov 2005, 36-99]. First of all, it is necessary to pay special attention to the load-bearing elements, the state of which is due to their structure of work and destruction features, and to establish:

1. Degree of development of cracks and other deformations in the damaged zone of structures

Untreated surfaces have to be examined first, since visually small defects are difficult to distinguish. For example with the presence of plaster coating, it is easier to detect the crack, but for evaluation of the structure's current state completely, the coating in the detection areas should be removed. This is done because the size of the cracks in coating does not always correspond to the size of the cracks in the masonry. Measurements of damaged zones are carried out in accordance with chapter 2.3.2.

2. Deflection or buckling of walls and columns

The presence of deformation of walls and columns can be conclude by the displacement against the enclosed structures such as joists, bridges, rafters, as well as by the presence of cracks in the plaster layer of the ceiling near the surveyed structure. However, it is possible to estimate the extent of wear of the structure only after measuring the degree of crack opening, the amount of displacement of one structure in relation to the other, and deviation from the vertical level, by checking the load on the thread along the surveyed site. In other case, special geodetic instruments should be used, if it is necessary to obtain more accurate dimensions.

There are a number of common properties and signs of the development of cracks in stone constructions for various purposes (Fig. 8), which help in the primary detection of potentially dangerous places.

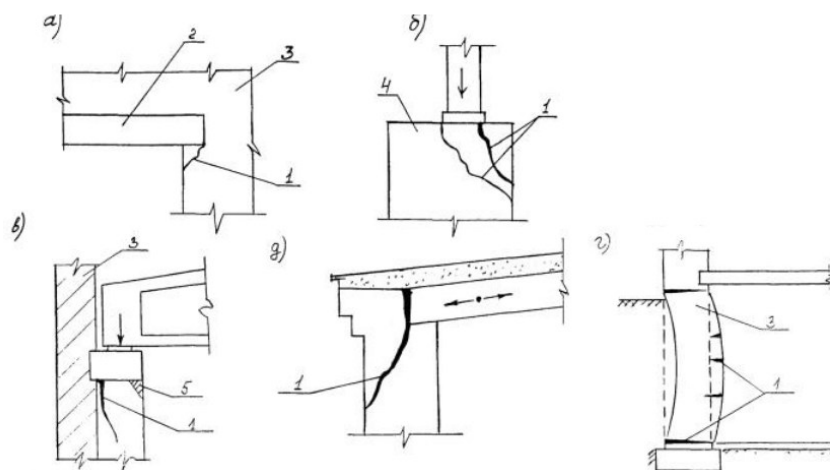
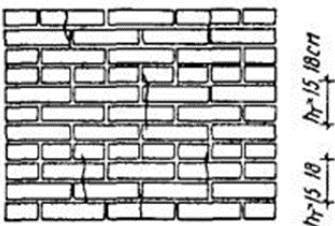
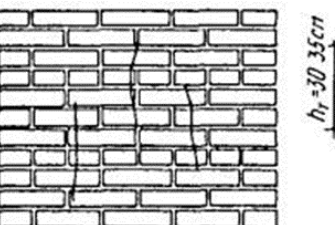
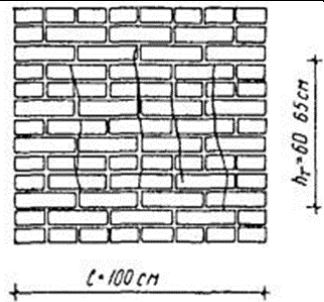
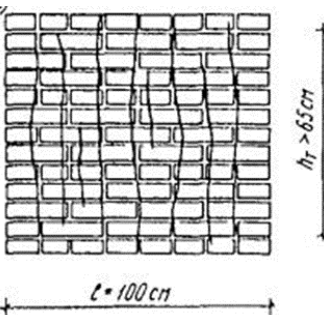

Figure 8. Damage of the masonry structures: a – cracks in the wall from shrinkage of the breastplate; b – cracks in the brick column with the load of its angle; c – cracks in a brick column from the bending of beams installed without backing material; d – crack in the cornice from the expanse at temperature deformations; 1 – cracks; 2 – breastplate; 3 – wall; 4 – column; 5 – steel beam.

A general assessment of the reliability and technical condition of various engineering structures, depending on their characteristic damage and taking into account the significance of certain types of structures, is presented in Table 3.

Table 3. Estimation of masonry structures condition by external characteristics

Condition category	Attribute of the force impacts on the structure	Attribute of the impact of the external environment
1 Good	Cracks in individual bricks that do not intersect the masonry joint, or complete absence of cracks	
2 Satisfactory 	Cracks, that crossing is less than two rows of masonry (length 15-18 cm).	
3 Not completely satisfactory 	Cracks, that crossing no more than four rows of masonry with a number of cracks less than four per 1 m of the width (thickness) of the structure; Vertical and diagonal cracks (regardless of the size of the opening), crossing less than two rows of masonry.	Defrosting and weathering of the masonry, detaching of veneer to a depth of up to 15% of the thickness.
4 Unsatisfactory	Vertical and diagonal cracks in the bearing structure to the height of less than four rows of masonry. Formation of vertical cracks between longitudinal and transverse walls	Defrosting and weathering of the masonry, detaching of veneer to a depth of up to 25% of the thickness.

	<p>Tearing or pulling out individual steel ties and wall anchors</p> <p>Local masonry damage to a depth of up to 2 cm under supports of trusses, beams and breastplates in the form of cracks;</p> <p>Vertical cracks along the ends of the supports, crossing less than two rows of masonry.</p>	<p>Slopes and buckling of walls and foundations within a floor is less than 1/6 of their thickness.</p> <p>The displacement of the slabs on the supports is less than 1/5 of the depth of the jointing mortar and less than 2 cm.</p>
<p>5 Unsuitable (emergency)</p> 	<p>Vertical and diagonal cracks in the bearing structure to the height of more than four rows of masonry;</p> <p>Separation of longitudinal walls from the transverse walls at their intersections;</p> <p>Tearing or pulling out of steel ties and wall anchors</p> <p>Damage to the masonry under the supports of trusses, beams and breastplates in the form of cracks to a depth of more than 2 cm;</p> <p>Crushing or displacement of rows of masonry along horizontal masonry joint to a depth of more than 2 cm;</p>	<p>Defrosting and weathering of the masonry, detaching of veneer to a depth of up to 40% of the thickness.</p> <p>Slopes and buckling of walls within a floor by 1/3 of their thickness and more</p> <p>Displacement of bearing structure along the horizontal masonry joint.</p> <p>The displacement of the slabs on the supports is more than 1/5 of the depth of the jointing mortar</p>

### 3. Humidity of brick walls

Several external signs such as fungal and mouldy damage, as well as condensate and salt deposits may indicate on the presence of an increased moisture content of the construction [Ulybin, Startsev & Zubkov 2013]. However, in addition to detecting such operational occurrence, it will be more important to investigate the causes of their occurrence, since in many cases the elimination of the causes can restore the structures to a normal state and give an idea of the suitability of specific technical solutions.

### 4. Physical and mechanical properties of masonry, stone and mortar

Detection and research of defects is not enough to issue recommendations and draw up a plan for restoring the load-bearing capacity ties of the structure. The material, from which elements are composed, plays the major role itself. Since the limiting values of the loads, that can be resist by the structure, depend on the material properties. It is impossible to understand the strength characteristics of the masonry by visual survey. Because of that, several methods are used.

If it is necessary to determine the strength of masonry in full-scale conditions without disrupting its integrity, it is admitted to use the following:

- The ultrasonic method [Guchkin 2001, 10] consists in calculating the supersonic transmission rate for the given parameters of the distance between the emitter and the receiver. The obtained

values are compared with the value of the curves on the graph, after which it is possible to conclude about the physical and mechanical properties of the masonry. In addition, the supersonic method helps to detect hidden defects that develop inside the structure.

- The radiometric method [Zolotozubov & Bezgodov 2014, 38-39; Masayasu 2016, 28] has a similar principle of working with supersonic method, but it is based on radiographic illumination of the structure, which has a great variety of applications. This method allows to find out the changes in density, bulk density, as well as to detect moisture inside the structure.
- The mechanical method [Zubkov, Ulybin & Fedotov 2015] In other words, the method of flat jacks – is based on fixing of the deformations of the masonry with a constant increase in pressure. The pressure is created by the jacks, which are mounted in pre-prepared cuts. As a result of the test, the values of the deformation characteristics of the masonry are obtained, namely the modulus of elasticity, determined both by calculation in a standard procedure, and by a direct flat-jack test.

For a more accurate adducing of the load-bearing capacity of the structure, the mechanical properties of the masonry are determined in laboratory environment. However, for taking samples, several mandatory conditions must be fulfilled:

- Selection could be made only from low-loaded areas;
- Samples have to be intact and without cracks;
- Sampling sites should be completely restored.

Now therefore, samples of a cubic or cylindrical shape are selected, which are subsequently loaded in the laboratory and subjected to other research, whose conduction is impossible in actual conditions. Although laboratory testing and is more accurate, however, realization of such survey is sometimes impossible because of the high cost, duration and the need to change the structure of the surveyed areas of the structure.

##### 5. Physical and mechanical properties of the reinforcement

When examining reinforced masonry structures, special attention should be paid to the condition of the reinforcement and the protective layer of the cement mortar for structures with the location of the reinforcement from the outside of the masonry.

As mentioned above, the survey stage is extremely important for drawing up a reconstruction plan. Analysis of the picture of defects obtained in full-scale survey, as well as the results of a laboratory survey give a complete picture of the nature of the defects, the causes of their appearance and possible measures to eliminate them or prevent further development.

## 3.2 Maintenance of reinforced masonry structures

### 3.2.1 Traditional methods of reinforcement and recovery

Recovery and strengthening of individual elements of buildings from masonry depends on the technical state of the masonry established during the survey [Nostroy 2013, «Rosmaks-Servis» n.d]. Methods of amplification can be classified into three groups, which are directly related to the three categories of technical condition, without taking into account the emergency conditions, so in this case, the repair work is not advisable. In turn, this leads to dependence on three types of masonry work, when the load begins to exceed the maximum bearing capacity.

1. The load-bearing capacity of the masonry, taking into account the existing weakening, is sufficient; damage of the masonry is insignificant; the general condition of the masonry is efficient and the reduction of the bearing capacity is not more than 15% of the original.
  - In this case, carrying out constructive measures for restoration is not required, and all existing cracks are filled with a solution (Fig. 9). This process is called plastering and it is carried out manually (at a depth of damage up to 40 mm) or by air placing with mortar grade M75 and higher on a cement base. To ensure a reliable adhesion of the plaster layer to the brickwork, the plastered surface have to be prepared, by the cleaning of masonry out of the damaged brick and mortar, washing and drying. With a large area and thickness of the plaster layer, it is essential to clear the bed joint to a depth of 10-15 mm, to make a surface notch on the masonry, and to install metal nets of wire or a glass mesh. Metal grids can be performed on site by tying wire around anchors with a diameter not exceeding the thickness of the bed joint. The edges of the mesh are wound over the damaged area for a length of at least 500 mm, and if the damaged area is near the corner of the building, the grid is turned around the corner to the wall by at least 1000 mm.

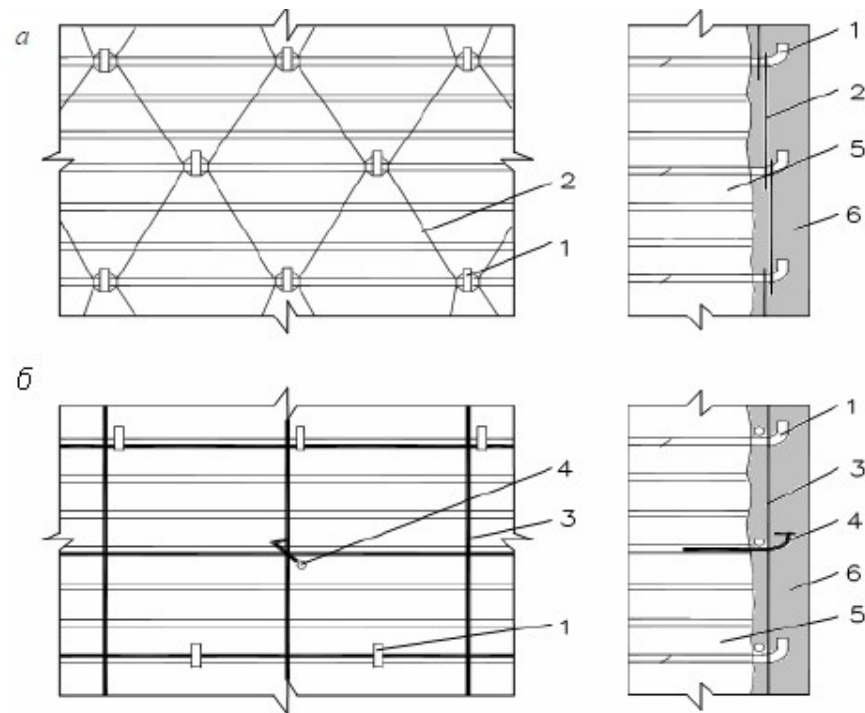

Figure 9. Restoration of brickwork: a – using strapping of wire, b – using grids: 1 – anchor, 2 – wire, 3 – mesh, 4 – nails, 5 – masonry, 6 – mortar

2. The load-bearing capacity of the masonry is satisfactory and no reinforcement is required, but the weakening exceeds 1/3 of the original strength, and there is a significant disintegrating of the masonry and a large number of cracks. The technical state of the masonry is assessed as being limited to work.
  - To recover and strengthen the masonry, which has through cracks of combined stresses and settlement character (with it's stabilization), cement and polymer solutions injection (Fig. 10) is used under the pressure up to 0.6 MPa with the help of injection devices. The design resistance of masonry reinforced by the injection of a solution into cracks is taken with allowance for the correction factor depending on the type of solution and the nature of the cracks

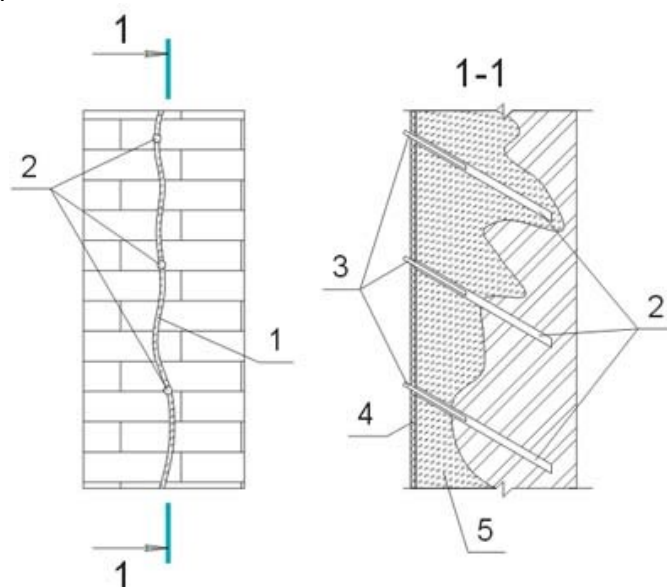

Figure 10. Injection of brickwork: 1 - crack; 2 – injection anchor hole, 3 – injection adapter sleeve, 4 – cement-sand mortar, 5 – crack, filled with mortar

- Partial (full) re-laying is carried out in the presence of a large number of small, single deep or full depth cracks with stabilized foundation settlement. For rebricking of masonry it's consider to use bricks and mortar not lower than the grade of brick and mortar to be restored, taking into account the preservation of the accepted binding of stones (Fig. 11).

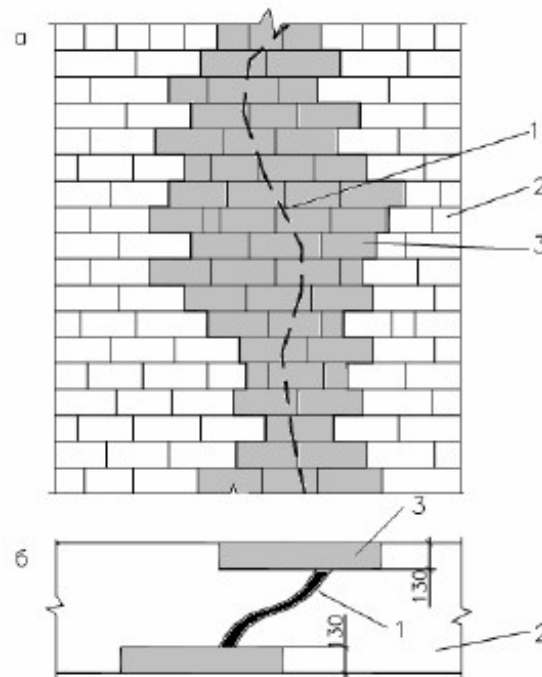

Figure 11. Restoration of masonry by partial relaying: a - partial relaying; b – top view: 1 – crack, 2 – restored wall, 3 – new masonry

- For local reinforcement of brick walls with through cracks of combined stresses and settlement character, steel staples are used. The ends of staples are fixed in the designed holes in the masonry to a depth of 100 mm or more, as well as lining from sheet or profile metal, fixed on the reinforced sections of the walls with the help of tightening bolts (Figure 12). Staples and steel fishplate can be placed with one or two sides of the reinforced area, on the surface, in wall lines and in pre-prepared toothings. The placement of the plates in the toothings is effective when the sections of the walls are divided by a crack, relative to each other vertically. Rolled profiles in the form of channels, angles, as well as strip steel with a width of 70 mm or more are used as the plates. After installing the plates, the toothings are filled with concrete and not filled plates are covered with anticorrosive compounds or plastered on a mesh.

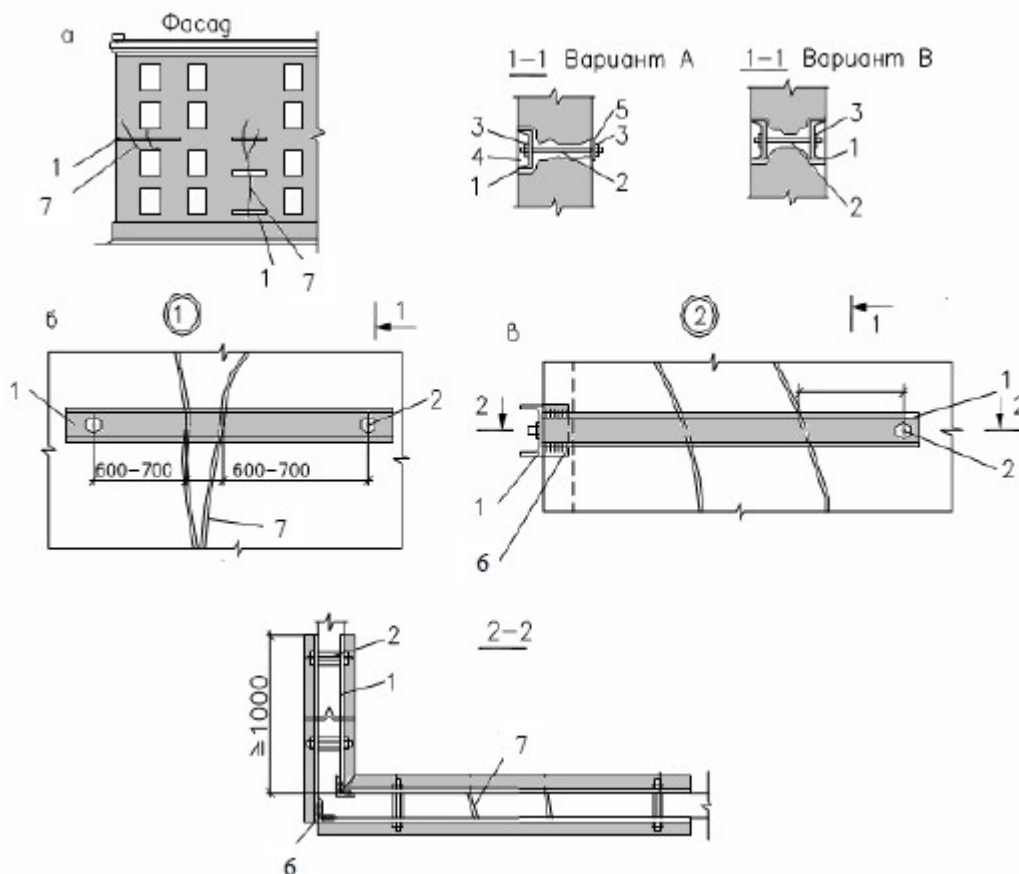

Figure 12. Battening plate: a – general view of the reinforcement, b – reinforcement of the partition, c – reinforcement near the building corner: 1 – steel fish plate, 2 - drawbolt, 3 - nut, 4 – toothing, 5 – support plate, 6 – Lsteel, 7 – crack

- The bearing capacity of masonry elements is insufficient; their technical condition is assessed as unacceptable (no operable). In this case, the gain is required.

An effective method of increasing the strength of masonry with small eccentricities is the device of casing: steel, reinforced concrete and mortar, which increases the load-bearing capacity of the masonry by 1.25-2.5 times with insignificant labour. The casing strengthen separate structural elements (poles, piers), as well as the sections of walls that work for central and eccentric compression.

- The steel casing is a system of longitudinal elements of the L profile (Figure 13), installed on the mortar at the corners or protuberances of the structure and welded to them by transverse elements (straps) in the form of stripe or reinforcing steel, as well as support pads. To commissioning the casing, the gaps between the masonry and the corners are crocheted or injected with a cement-sand mortar, after which the steel corners are closed with a metal mesh for reliable adhesion of the mortar. It is recommended to strain the transverse strips to improve the efficiency of the reinforcement. For this, from the side of two opposite faces to the longitudinal elements only one end of strap is welded. After that, the bars are heated to 100-120 ° C and the second free end is welded in the



heated state. As a result, when the straps cool down, the reduction of the reinforced structure occurs.

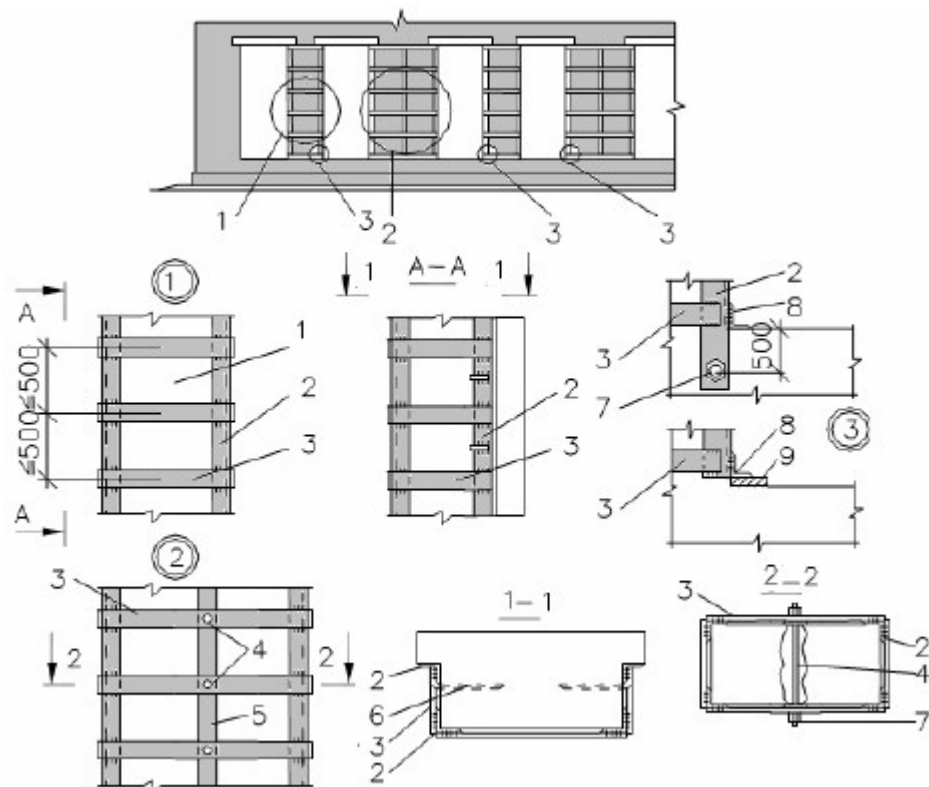

Figure 13. Steel casing: 1 – reinforced construction, 2 – L profile, 3 – strap, 4 – cross-binding, 5 – stake, 6 – anchor, 7 – bolt, 8 – support bracket, 9 – steel plate.

- The reinforced concrete casing (Fig. 14) is a reinforcement cage made of longitudinal and cross reinforcement, which is homogenized with concrete. This type of casing is used for critical damage of the masonry and can significantly increase the strength of its elements. The thickness of the cage, concrete layer and the cross-sectional area of the reinforcement are determined by calculation. Concreting is carried out by injecting, pumping the mixture through injection holes in the formwork, by spraying or by sequential concreting with the formwork. Moreover, it is good practice to lead the strengthening of damaged elements with the subsequent injection of a masonry damaged by cracks with cement mortar, which provides the highest bearing capacity of structures.
- The reinforced mortar casing is made in analogy with reinforced concrete, by means of a mortar grade of not less than M50 instead of concrete. The mortar casing allows to maintain the existing cross-sectional dimensions practically unchanged. The cement mortar, applied by a thin layer of the order of 30-40 mm, performs the function of the connection between the reinforced masonry and the reinforcement and protects it from the corrosion.

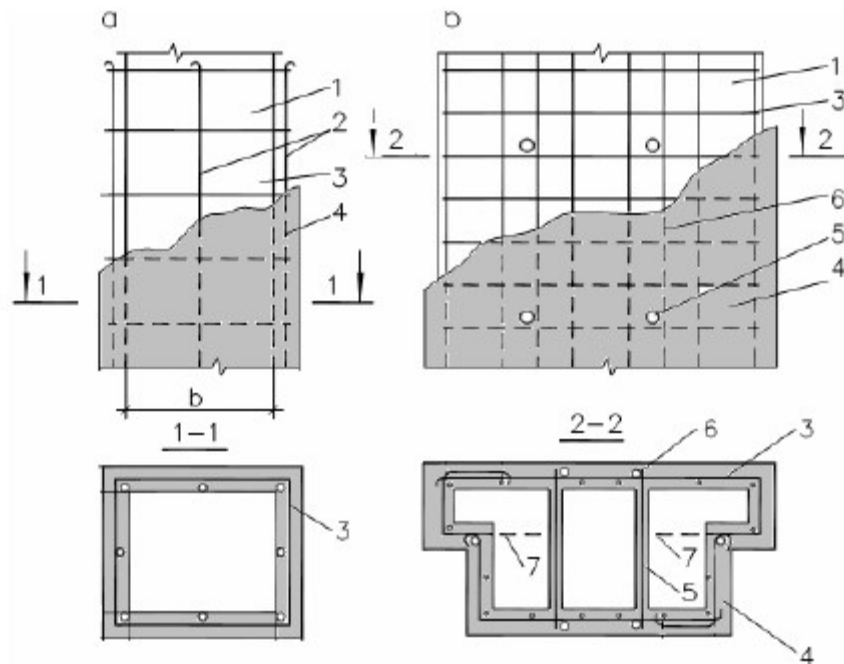

Figure 14. Reinforced concrete casing: a – column; b – piers: 1 – reinforced structure, 2, 6 – longitudinal reinforcement, 3 – cross reinforcement, 4 – concrete, 5 - additional cross-binding, 7 - anchors

- There is another solution in a case, if it is forbidden to break walls for architectural reasons or if the dimensions of their cross sections are small and the load must be significantly increased. The reinforcement can be performed by a metal or reinforced concrete core placed in a vertical niche in the wall (Fig. 15), which could be carried out from one or two sides.

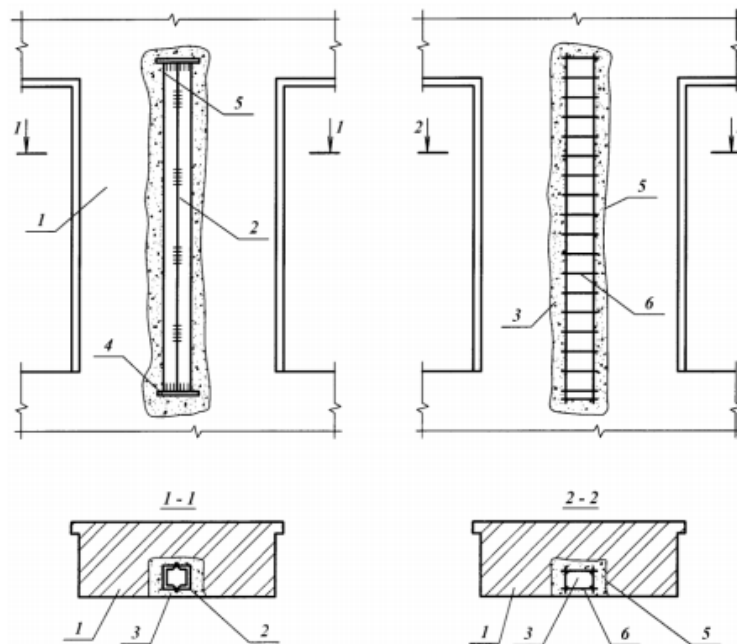

Figure 15. Strengthening of stone piers with the supporting core: a - welded from two channels; b - reinforced concrete; 1 - amplified partition; 2 - steel core; 3 - concrete class; 4 - steel core support plates; 5 - vertical niche, pierced in the wall; 6 - reinforcing cage.

In addition to the abovementioned methods of masonry reconstruction, it is necessary to single out in a separate group the methods for removing masonry from excess moisture. This direction is based not only on the elimination of defects caused by the action of moisture, but also on getting rid of the cause of its appearance.

- Electro-osmosis method [Ivliev 2007]

This method is based on the principle of removing moisture from the structure by giving water molecules a negative charge and then attracting to a positive charge (Fig. 16). Positive electrodes are installed at the bottom of the wall, which allows pumping water out of the structure with the salt dissolved in it. The physical characteristics of the event are calculated separately for each object.

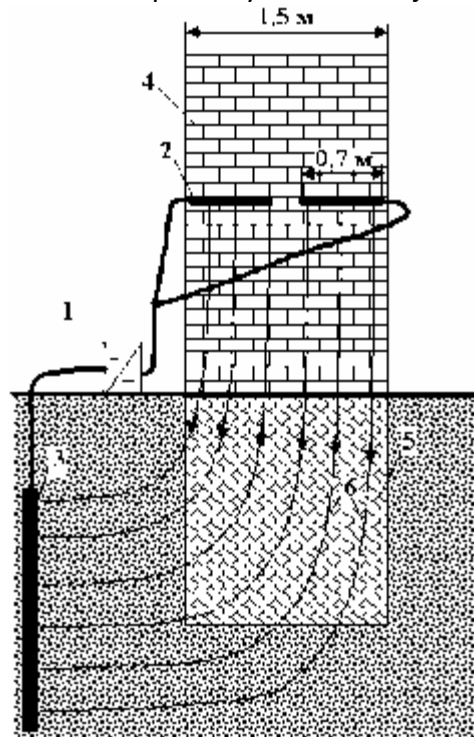

Figure 16. Electro-osmosis method: 1 - dc generator, 2 - the electrodes (anodes), 3 - the electrodes (cathodes), 4 - the dried wall, 5 - the foundation, 6 - the electric current line, 7 - the level of capillary rise of moisture in the wall.

- Mechanical cutting

This method consists in cutting the wall along the entire perimeter, where a metal plate or sheet of synthetic materials is subsequently inserted. After processing with epoxy materials or other solutions takes place, that prevents further movement of moisture. However, this method is extremely damaging to the integrity of the structure and it can cause its destruction.

- Chemical barrier

The method has common features with mechanical cutting, but it has less effect on the integrity of the wall. The essence of the method is to introduce a solution around the entire perimeter through specially prepared holes in order to form a layer, which separates the capillary system of the building. Thus, the dampness decreases and the obstacle

is created for further migration of moisture from the lower part of the structure.

- Siphoning or drainage  
Drainage is economical and labour-intensive way to reduce the humidity of the masonry. It consists of introducing special pipes into the wall structure through which moisture is collected and discharged. The dimensions of the pipes depend on the initial humidity conditions and the parameters of the wall itself.

It should be noted the individual approach to the choice of the strengthening and recovery method in each particular case. The preference should be given to such a method, in which the best effect is achieved with a minimum consumption of materials and labour.

### 3.2.2 Modern technology of reinforcement

The above methods of restoring and strengthening the bearing capacity of stone structures are laborious in implementation and often violate the architectural integrity and expressiveness of the element, which for aesthetic reasons is not appropriate. With the usage of new building materials and technologies, as well as with the skilful introduction of them into the project, it is possible to minimize the negative aspects, thereby shortening the time of work, retaining the original appearance and increasing the physical properties of the facility at lower costs.

1. One such method is the use of nets made of composite materials, such as hydrocarbon fibres or glass fibres. The combined use of such composite materials and epoxy glue is called Fibre Reinforced Polymers whereby a connection to the reinforced structure occurs (fig. 17). [Shilin, Pshenichnyy & Kartuzov 2007; Antakov 2014; "Kompozit" n.d] Basically, this method is used for minor damages, when it is necessary to prevent the formation of cracks.



Figure 17. Example of Fibre Reinforced Polymers strengthening

According to the results of measurements, the reference to the hardness characteristics of such a system is often higher than steel, which provides its wide range of applications.

However, in addition to visible advantages, there are a number of shortcomings:

- Need for thorough preparation of the surface before use;
- Strict thermal and humidity conditions;
- Low melting point of the glue joint, low durability due to aging and high toxicity.

2. Application of plaster solution of inorganic mineral materials with modified polymeric additives, instead of adhesive bonding, helps to eliminate the noted shortcomings. A similar system is called Fibre Reinforced Cementations Matrix [Antakov 2014; Stukach & Sharapov 2016] or Ruredilx Mech, as one of the varieties (Figure 18).



Figure 18. Example plaster layer strengthening

The connection with the reinforced structure occurs by applying a thin plaster layer to the surface and then embedding the reinforcing mesh. After that, a repeated protective layer of plaster is applied, into which, if necessary, an additional grid can be integrated for providing increased strength. Thus, the application of the plaster layer provides:

- Usability and possibility to enhance any form;
- High adhesion of the reinforcing plaster layer to the surface of the reinforced masonry;
- High compatibility of reinforcing layer with brickwork;
- High vapour permeability and corrosion, fire and water resistance.

It is worth mentioning mention that the application of the plaster layer also helps in cases associated with increased moisture content of the structure. For instance, depending on the reasons for the appearance of moisture, waterproof plaster could be chosen, as well as a coating that allows moisture to evaporate or non-shrinkage solutions and those that protect the wall from condensation.

3. Effective methods, which have found application in construction practice, include strengthening with the use of spiral connections and

anchor joints [Startsev & Sundukova 2014; Shilin, Pshenichnyy & Kartuzov 2007]. Such a method is used, if necessary to prevent the formation of cracks, in case of increasing the load, or to stop the growth of existing structures, with minimal damage to the external appearance of the structure. To do this, spiral rods are fixed in the hoard in pre-drilled holes with a special cement mortar or by driving and screwing. Thus, there is an opportunity for various manipulations, such as lapping or multiple rods at once, as well as laying at different angles and in different directions.

Laboratory tests and the practice of using steel rods and composite grids demonstrate that the greatest gain can be achieved if the fibres are positioned perpendicular to the cracks. Due to this, it is possible to increase the brickwork rates for tensile, which are initially much smaller than for compression.

### 3.3 Inference

When working with masonry, it is critical to keep in mind the presence of factors whose influence adversely affects the integrity of the structure and on which the correctness of decision-making depends. This requires an understanding of the behaviour of the structure due to the impact of these factors, as well as the causes of their occurrence and signs of appearance. The analysis of factors helps to determine the individual approach to each element, which would be both economically verified and have the most recovering impact on the structure. Thus, with the knowledge of the available ways of carrying out reconstruction works, personal experience and theoretical basis, it is possible not only to return the constructions to their original physical and mechanical properties, but also to impart new ones that increase its properties and meet modern requirements.

## 4 CONSIDERATION OF RECONSTRUCTION METHODS ON THE EXAMPLE OF A WORKING PROJECT

The relevancy of having certain rules for the reconstruction of buildings, described in chapter 2, can only be shown on the example of an existing project, the experience of which has served as the basis for the study of this topic. As was mentioned above, with the lack of primary knowledge about the work stages on the site, with the negligent approach to the existing building and with inappropriate usage of compulsive items, the reconstruction of the building is endangered to turn into a failure for both the building owner and the company doing the work.

### 4.1 Information about the object of reconstruction

The reconstructed building is located in Moscow at the address ul. Kalanchevskaya 45. According to available data it could be determined that the construction dates back to the beginning of the 20th century. During the renovation of the city centre, the building was leased for an extended term with the aim of organizing an auto-wash complex on its territory (Chapter 2.1). However, for the first time, when the reconstruction of the building was carried out, only minor aspects were touched upon, such as small changes in the floor's covering, the installation of entrance units and cosmetic changes, to bring carwash into operation. In other words, the building was subjected to partial renovation. Consequently, this situation obliged to conduct new construction activities with the prospect of a long-term use of a building in an aggressive environment, in order to prevent it from losing its applicability over time. Now therefore, during the drafting of the project, both architectural and constructive tasks were solved:

- Giving the architectural expressiveness (Fig. 19), since the building did not fit into the developing uniform appearance of the quarter.
- Transformation of the inner layout, in order to ensure the greatest circulation of passing machines.
- Changing of engineering systems, to provide a comfortable microclimate for different rooms separately.
- Strengthening of structures, which is associated with the presence of other works and with a huge deterioration in the condition of the building during its operation as a car wash complex.





Figure 19. Architectural building model

Since the car wash is in operation, several requirements must be observed in order to be able to successfully implement the project. Firstly, the combination of installation works with car wash activities (Fig. 20) in such a manner to let the part of the washing continue its operating and to evade obstructions and hindrances to traffic of cars entering the building (this method is considered in chapter 2.3.4). It was possible to ensure due to the presence of several posts and entrances, as there was a gradual circulation and distribution of working processes between them. While the floor was being poured or columns were reinforced in one place, the cars could continue to drive in from the other end of the building. Otherwise, in some cases it was advisable to carry out work in the night or in the evening.



Figure 20. Carwash work place

Secondly, the maintenance of the indoor climate at an acceptable level (Chapter 2.3.3). The difficulty during the reconstruction process was that the air temperature ranged from 13-16 degrees, which is not sufficient for people to work in a comfortable way. This means that all installation works that require structural integrity violations must be carried out in a short time, since a stop of the complex's work for a long period is unacceptable. Suchwise during the erection operations of changing input groups or performing work to strengthen the edges of the wall, cold air from the street in large quantities begins to flow inside. These circumstances also slowed down the reconstruction process, which limited the possibility of applying some options.

Thirdly, the usability of the construction (Chapter 2.3.6), which implies the need for reinforcement and architectural changes in such a way to avoid



possible negative effects of external factors during the operational activity down the road [Figure 21]. Since in view of the features of the car wash, the building's structural elements inevitably encounter the effects of high humidity and aggressive chemical compounds. Therefore, it was necessary to isolate all elements and to prevent from randomly break their integrity, even when the elements did not have a protective layer and they were in direct contact with the aggressive environment.



Figure 21. Example of job matching

Aside from those present, during the work there were problems of a different nature. However, since they are mainly connected with the documentation procedure, interaction with suppliers and the relationship between the customer and the contractor, their consideration in the context of the work is not necessary. Except for the fact, that work's delays caused by external causes should be taken into account at the stage of coordination and drawing up of conducting plan.

Thus, it appears that in the case of a specific project, there was no time for long clarification of certain issues, and therefore the solution of the tasks associated with each stage had to be taken into account in conjunction with others.

#### 4.2 Physical and technical parameters of structural elements

The object of reconstruction is a single-storey building with adjoining small household outbuildings, which in plan has the form of a pentagon with different lengths of faces and a total area of more than 500 m<sup>2</sup>.

As can be seen from figure 22, the building is surrounded on the one hand by the construction of the future 6 storey building, on the other hand by existing building and besides that, the part of the facade of the building goes to the open view from the street. Thus, such a neighbourhood, as was testified above, served as one of the reasons for carrying out iterated works on reconstruction.



Figure 22. Snapshot of terrain with Google maps

### 1. Design features of the building

The soil under the building is an urbanozem (35), in other words the soil that was artificially developed during the formation of the urban environment. The condition of the soil, from the analysis of field studies and documents (Fig. 23), as well as the lack of urban communications passing under the building, indicates that the probability of building settlement is low under the conditions of projected loads. Thus during the survey, possible reasons for the appearance of certain defects are cut off.

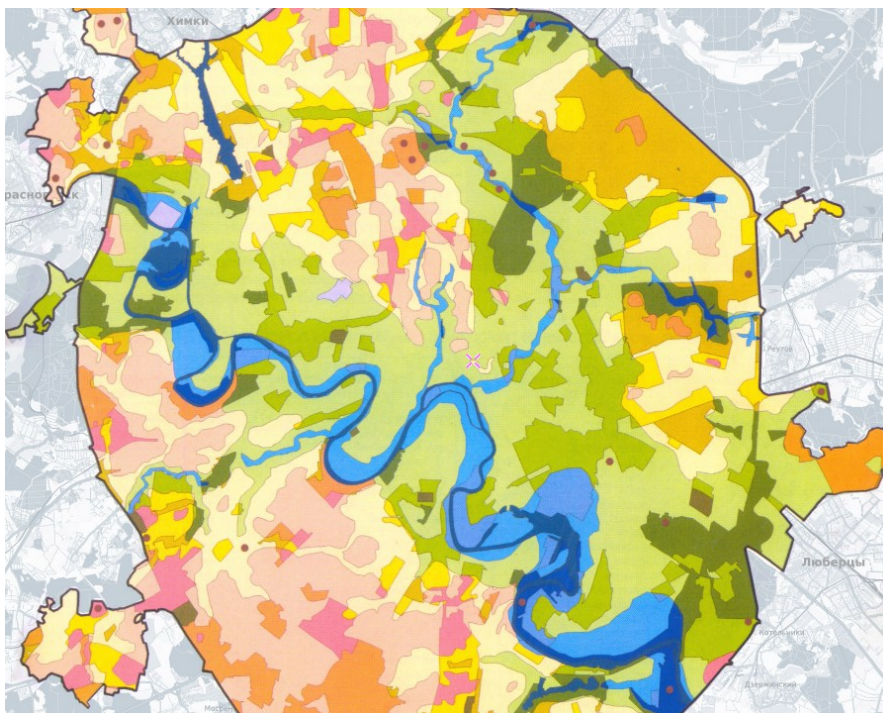

Figure 23. Soil map of Moscow

The conditions of the foundation and the flooring are difficult to classify because of the large number of changes made in their structure during the entire lifetime of the building. Therefore, during the work on the pouring of new floors it was found that the original was consisted of several layers

of concrete, cement-sand mixture, brick and stones. However, since the device of the floor, with the exception of the places of the load application from the columns, did not play a big role in drawing up the reconstruction plan, in view of the fact that it was necessary to completely remove all existing layers and replace them with new ones, their device will not be considered.

The bearing component of the building is brick walls along the perimeter [Fig. 24], whose thickness varied from 400 to 600 mm, depending on the location and their condition. Inside the building there were brick columns equidistant from each other, which supported the roof and demarcated the space of the premises. Thus, during the survey of the building, most of the attention was paid to these structural elements, since in addition to specifying the geometric characteristics, which anyhow were documented during the previous works, it was required to determine their physical characteristics at the moment.

The roof of the building is a flat concrete slab supported on a crossbar system. As in the case of the flooring, traces of repeated interference in the structure are observed on the roof, for example, for the purpose of repairing from leaks or for the installation of domelights, which were blanked off several times afterwards. Such a reorganization did not significantly affect the final weight of the structure, but worsened its physical condition and thermal characteristics.

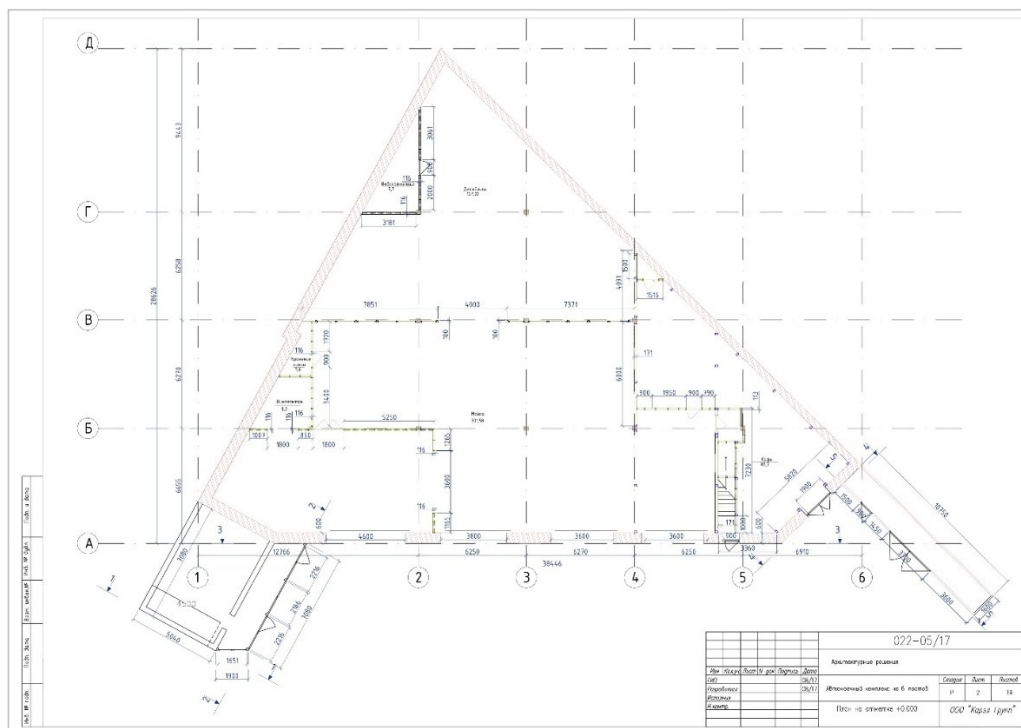

Figure 24. Building plan

## 2. Localization of faults and defect

The construction survey was carried out, as described in chapter 2.3.2, in several consecutive stages.

Firstly, the study of data that is in the public domain about the location, the state of the soil, the history of the region, etc. Then the data after previous works was obtained, on which bases, it was possible to immediately determine the most problematic places of the building, without the need to survey the entire structure as a whole, since the structural elements are the same and subjected to the same wear. Also, on the authority of the received data, it was possible to find out the dimensions of the building and to shorten the time for measuring work, in view of large areas. However, such an assumption subsequently led to the fact that the actual dimensions and dimensions of the virtual model of the building did not match. This entailed a shift in timing and trivial financial losses.

Thus, the spotting-up with the most characteristic defects after the preliminary examination is presented in Table 4.

Table 4. Example of the sheet of defects

No	Type of the defect	Localization and description of the defect	Notation
1	Changing the geometry of the wall	Between 2 and 3 a row of columns In the axes '1-2' / 'B-Г'  Visible deflection of the wall by more than 6 cm	<u>Unsatisfactory</u>  Possible cause - mechanical damage due to inaccurate handling of equipment
2	Crack in the plaster layer of the ceiling	~ <i>Place of defect No. 1</i> ~  Thin crack from the joint of the ceiling and the wall at 1.5 m	Indicates a slight displacement of the concrete panel relative to the initial position
3	Peeling of the plaster layer	~ <i>Place of defect No. 1</i> ~  Peeling and alligating of plaster in the place of deflection	
4	Horizontal cracks	Position in the '3- B' axes  Cracks along the entire height of the column passing through 3-4 rows of masonry	<u>Unsuitable (emergency)</u>  Possible causes - excessive loading, structural aging, errors in design or installation
5	Joint splitting	~ <i>Place of defect No. 4</i> ~  brickwork joints start to split with little interaction, creating voids	Possible cause - excessive loading and the subsequent action of moisture

From there it becomes clear that in addition to strengthening some sections of the structure, it would be required to carry out works of ensuring sufficient moisture protection and of replacing the existing finishing cover.

### 3. Physical properties of structural elements

During the collection of information on the condition of the building it was elected not to use the laboratory method of inspection by reason of the personal request of the customer and in view of the inadmissibility of destruction of the structure. However, research should still be carried out to obtain a complete picture of the condition of the construction. Thus, mobile methods were used which did not destroy integrity of structural elements and which could be used only in the most dangerous places, detected during visual inspection.

As a result, it was found out that the masonry is made of loam bricks, which correlated with today's classification have mechanical properties similar to the brands of brick 125-150. Such behaviour could be explained by the fact that the material was manually moulded, heavily pressed and then baked in special ovens. That manufacturing process made the brick very durable and frost-resistant material. However, as shown in chapter 3.1.1, the maximum values of load resistance of masonry depend not only on the properties of the stone used in the construction, but also on the state of solution. Consequently, according to the fact that the condition of the masonry joints have worsened during the existence of the building, the load-bearing capacity of the entire masonry has greatly reduced as well. From there for further calculations, the filling of the masonry joints is adopted as having similar properties with grade 4 or not bearing at all. Then in compliance with established values, the values of the design resistance of the masonry to compression and other characteristics could be taken from the tables indicated in Appendix 2 and 3.

Summarizing, according to the results of the survey of the main elements of the building it can be concluded, that the greatest interference requires a brick structure, since they were most affected during the operation of the building. Even though, under the conditions of existing loads and operating conditions, the presence of developed defects did not have a significant effect on the state of the structure, because the elements were in harmony and in joint action with each other. Nevertheless, since the project meant the complete reconstruction of the building and reorganization for other tasks, then, respectively, if the conditions in which the building is located change, the defects continue to rapidly progress, which will lead to collapse.



### 4.3 Load summary

#### 1. External forces from materials

One of the prerequisites for the reconstruction project was the roof insulation, as according to the results of the heat engineering inspection it turned out that the greatest heat losses fall on the concrete panels on the roof. (Fig. 25)[SP 70.13330.2012].

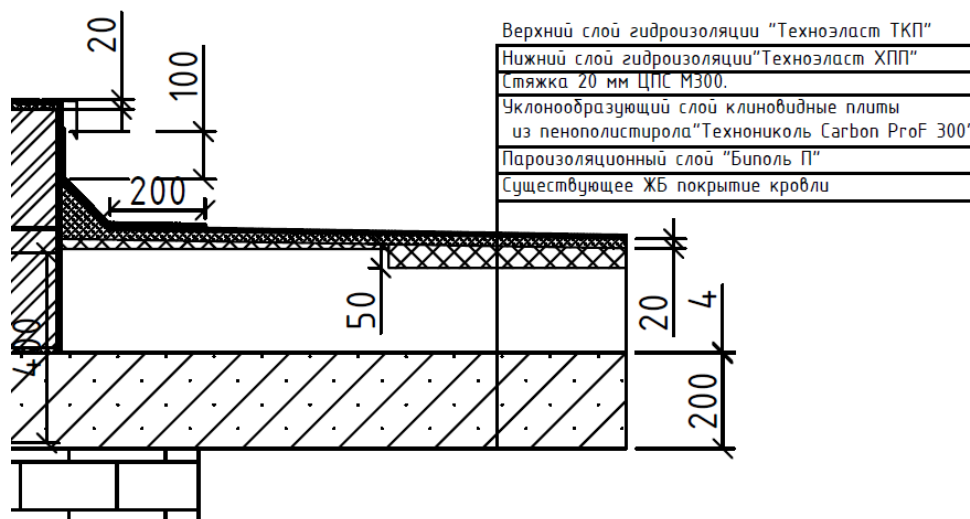

Figure 25 Composition of roofing materials [Appendix 1]

The second required condition was the presence of an industrial ventilation system, to ensure a sufficient humidity regime of the premises, with subsequent masking of the systems with suspended ceiling devices, which also affects the total weight of the roof.

Therefore, the composition of the roof is:

- 1) Top layer of waterproofing "Technoelast"
- 2) The lower layer of waterproofing "Technoelast"
- 3) Cement-sand screed M300 - 20 mm.
- 4) Inclined forming layer of expanded polystyrene "Technonickol Carbon Prof 300" – 200 mm
- 5) Vapour barriers layer
- 6) Existing reinforced concrete floor - 200 mm
- 7) Frame of gypsum profiles "Knauf"
- 8) Profile sheet C-8

Knowing the structure of the roof layers and the elements that interact with it, it is possible to determine the weight of 1 m<sup>2</sup> of load area for which purpose it is most convenient to compile a table of materials [table 5].

Table 5. Material table:  $\gamma_m$  – load effect/reliability factor, F – mass of the layer per m<sup>2</sup>, P – weight of the layer per m<sup>2</sup>

Materials	F kg/m <sup>2</sup>	$\gamma_m$	P kN/m <sup>2</sup>
Inclined forming layer of expanded polystyrene ( $\rho=40$ kg/m <sup>3</sup> )- 200 mm	8	1.3	0.104
Cement-sand screed M300 ( $\rho=1820$ kg/m <sup>3</sup> )- 20 mm	36.4	1.3	0.4732
Existing reinforced concrete floor ( $\rho=2500$ kg/m <sup>3</sup> ) -200 mm.	500	1.1	5.5
Frame of gypsum profiles	13	1.2	0.156
Profile sheet C-8	4	1.2	0.048
ventilation pipes	5	1.2	0.06
<b>TOTAL</b>	<b>566.4</b>		<b>6.3412</b>

*Note: the weight of the vapour barriers and waterproofing is not taken into account due to its low weight.*

Thus, the total load from the roof covering, taking into account the correction factors, is  $P = 6.34 \text{ kN/m}^2$

## 2. Snow load

The characteristic value of the snow load on the horizontal projection of the coating is calculated by the formula in accordance with SP 20.13330.2016:

$$S_0 = \mu_1 * C_e * C_t * S_g = 1.8 \text{ kN/m}^2 \quad (1)$$

$\mu_1$  – Coefficient of transition from the ground snow load to the snow load on the roof covering; Since the roof is one-pitch with a slope of less than 30°  $\mu_1 = 1$ ;

$C_e$  – Snow drift coefficient; Since protected from direct wind impact by neighbouring higher buildings, distant by less than 10h:  $C_e = 1$ ;

$C_t$  – Thermal coefficient; Since the roof is heat-insulated and heat emission is not enough to melt the snow on the roof:  $C_t = 1$ ,

$S_g$  – The normative value of the ground snow load on 1 m<sup>2</sup>; Since Moscow is relating to the III snow area:  $S_g = 1.8 \text{ kN/m}^2$

## 3. Wind load

The characteristic value of the main wind load on the roof of the building is calculated by the formula in accordance with SP 20.13330.2016:

$$\omega = \omega_p + \omega_m = -0.113 \text{ kN/m}^2 \quad (2)$$

$\omega_p$  – Oscillatory component; Since one-story production buildings 5 m high with a height to width of span ratio of less than 1.5:  $\omega_p = 1$

$\omega_m$  – Characteristic value of the average component of the main wind load. Determined by the formula 3.

$$\omega_m = \omega_0 * k_z * C = 0.113 \text{ kN/m}^2 \quad (3)$$

$\omega_0$  – Wind pressure; Since Moscow is relating to the I wind region:  
 $\omega_0 = 0.23 \text{ kPa}$

$k_z$  – Coefficient that takes into account the change in wind pressure. Determined by the formula 4

$$k_z = k_{10} * \left(\frac{z_e}{10\text{m}}\right)^{2\alpha} = 0.493 \quad (4)$$

$k_{10}$  – The coefficient, taking into account the change in wind pressure by 10 m; Since the type of construction site B:  $k_{10} = 0.65$

$z_e$  – Equivalent height; Since  $h < d$  then the height of the building:  
 $z_e = H$

$\alpha$  – The empirical coefficient, since the type of terrain construction B:  
 $\alpha = 0.2$

$C$  – Shape factor/aerodynamic coefficient; Since the calculated roof has a small area and is located at an angle to the horizon given by the coefficient neglected:  $C = -1$

#### 4.4 Calculation of the wall strengthening by reinforced concrete casing

From chapter 3.1.1 it is clear that the masonry can withstand high loads considering high compression strength characteristics, but in the case where cracks begin to appear, further destruction is inevitable. Therefore, although the laying of load-bearing walls was originally designed with strength reserve, these values require rechecking because of detected reduction in the cross section by a factor of 1/3 and aging of the solution. Otherwise, in such a situation, when the loads that inevitably follow during the reconstruction change, new cracks can start to appear, while old one continue to develop having that entails a local collapse.

To strengthen the walls, as discussed in chapter 3.2, there are several different ways, the main idea of which is to transfer the load to the reinforcement and include the gain in the design work. Accordingly, with the equivalence of results, the choice of one or another method is contingent on only to the presence of external factors. Such factors include the convenience of installation and the resources necessary for its



implementation, as well as the presence of a defect that requires local intervention, which was found out as a result of the survey. Thus, the best from a constructive and aesthetic point of view will be the combination of methods for the construction of a concrete casing, solution, as well as the introduction of rods [SP 63.13330.2012]. It will allow the walls to be levelled and the masonry to be strengthened by compression, shearing, crushing and bearing.

#### 4.4.1 Actual bearing capacity of the wall

##### 1. Load summary

Due to the complex geometry of the building, different parts of the structural elements may be subject to different loading in the plan. Therefore, the collection and calculation of loads on load-bearing structures turns into a solution of a rather nontrivial task, requiring not only a specific area, but the entire building as well. There is a need for special calculation programs in which it is possible to create a volumetric physical model of a building with its subsequent loading. In some cases, this method is indispensable, since it gives a clear idea of the design work, its weak points, and so on. Nevertheless, in some cases the question arises about the advisability of using such software, because the results would not be much different from the approximate calculation, which means the spent efforts would not be worth the time spent.

In view of such factors, during the design of the reinforcement of the bearing wall section, it was decided not to resort to the use of programs, since the approximate geometry of the distribution of loads, from the experience of past works, was clear. Hence, by calculating the strengthening at a higher load, the conditions for the acting load will also be met. The load, as shown in Figure 26, is considered to be one running meter ( $B = 1\text{m}$ ) from a length segment  $L = 4\text{m}$ .

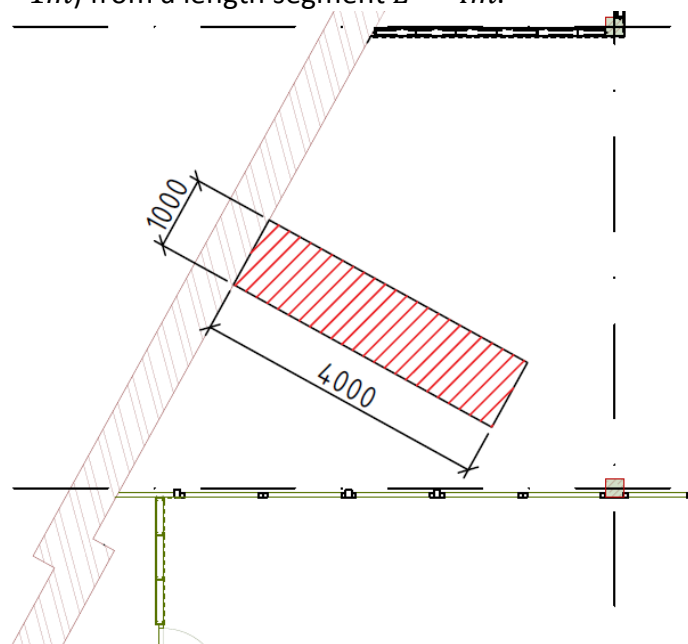

Figure 26. Loading area per section of the wall

The value of the total longitudinal force on the section of the wall can be found through the sum of the dead loads and permanently acting load relative to the painted area, taking into account the load reliability factor for each type.

$$F_{tot} = 1.4 * F_C + 1.4 * F_S + 1.4 * F_W + 1.3 * F_1 = 51.39kN \quad (5)$$

$$F_C - \text{Concentrated load from the roof } F_C = P * B * L = 25.3kN$$

$$F_S - \text{Concentrated snow load } F_S = S_0 * B * L = 7.2kN$$

$$F_W - \text{Concentrated wind load } F_W = \omega * B * L = -0.45kN$$

$$F_1 - \text{Concentrated loading from the parapet } F_1 = b * 0.5m * h * \rho_m * 1.1 = 4.95kN$$

## 2. Specification of the eccentricity

From the sectional view of the building in Figure 27, it can be seen that forces acting on the wall are displaced relative to the axis of symmetry. The presence of displacement leads to the fact that the forces begin to bend the structure, since a bending moment is created, and this also leads to a reduction in the area involved in the work.

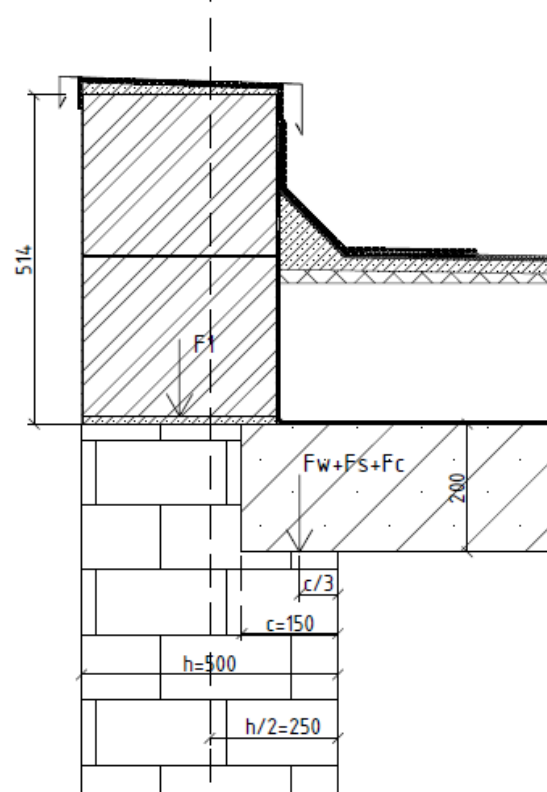

Figure 27. Force application

Thus, it becomes necessary to find the eccentricity of the total longitudinal force relative to the axis of symmetry of the wall, which is subsequently used to determine the actual physical values of the masonry, and which can be found from:

$$e_0 = M_{tot}/F_{tot} = 175mm \quad (6)$$

$M_{tot}$  – The calculated bending moment. Since the load from the roof, as well as the load from the parapet, are displaced from the centre, the moment has to be calculated as the total sum of two moments. However, in the case of the parapet, its displacement is small relative to the centre, and therefore may not be taken into account. So the formula for finding the total moment looks like  $M_{tot} = (F_c + F_s + F_w) * e$

$e$  – Eccentricity of longitudinal force, which is equal to  $e = h/2 - c/3 = 200m$ , since the point of load application is at a distance of  $1/3$  from the edge of the wall

### 3. Load-bearing capacity of the wall part

The load-bearing capacity of the masonry can be determined from the formula 7 [SP 15.13330.2012]:

$$N = m_g * \varphi * \omega * R * A_c \quad (7)$$

$m_g$  – Coefficient that takes into account the effect of the duration of the load, which for a given masonry  $m_g = 1$

$\varphi$  – Buckling coefficient depending on the flexibility and elastic characteristics of the masonry

$\omega$  – Empirical coefficient; for a rectangular section can be found as  $\omega = 1 + e_0/h = 1.351$

$R$  – Design strength of the masonry; the value for masonry based on survey results is  $R = 1.1MPa$

$A_c$  – Effective area of the compressed section with a rectangular stress diagram determined from the condition that centre of gravity coincides with the point of application of the calculated longitudinal force

Thus, it is first necessary to find the useful cross-sectional area of the wall that participates in the work. As noted above, in the presence of eccentricity, the compression section decreases, as shown in Figure 28.

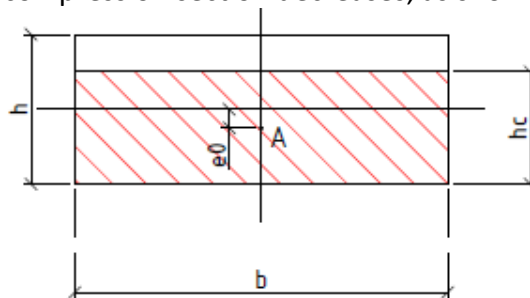

Figure 28 Effective area

In this case, for a section of a rectangular shape, the value of the area working on compression, is found from condition  $A_c = b * h * (1 - 2 * e_0/h) = 0.149m^2$

Taking into account the change in cross-sectional area and the presence of eccentricity, which involves only a part of the wall, the buckling coefficient for such case must be found as the arithmetic mean of the coefficient values for the total cross section and for the effective:

$$\varphi_1 = \frac{\varphi + \varphi_c}{2} = 0.45 \quad (8)$$

Table 6. Table of the relationship of flexibility and the buckling coefficient

Гибкость		Кoeffициент продольного изгиба $\varphi$ при упругих характеристиках кладки $\alpha$						
$\lambda_h$	$\lambda_l$	1500	1000	750	500	350	200	100
4	14	1	1	1	0,98	0,94	0,9	0,82
6	21	0,98	0,96	0,95	0,91	0,88	0,81	0,68
8	28	0,95	0,92	0,9	0,85	0,8	0,7	0,54
10	35	0,92	0,88	0,84	0,79	0,72	0,6	0,43
12	42	0,88	0,84	0,79	0,72	0,64	0,51	0,34
14	49	0,85	0,79	0,73	0,66	0,57	0,43	0,28
16	56	0,81	0,74	0,68	0,59	0,5	0,37	0,23
18	63	0,77	0,7	0,63	0,53	0,45	0,32	-
22	76	0,69	0,61	0,53	0,43	0,35	0,24	-
26	90	0,61	0,52	0,45	0,36	0,29	0,2	-
30	104	0,53	0,45	0,39	0,32	0,25	0,17	-
34	118	0,44	0,38	0,32	0,26	0,21	0,14	-
38	132	0,36	0,31	0,26	0,21	0,17	0,12	-
42	146	0,29	0,25	0,21	0,17	0,14	0,09	-
46	160	0,21	0,18	0,16	0,13	0,1	0,07	-
50	173	0,17	0,15	0,13	0,1	0,08	0,05	-
54	187	0,13	0,12	0,1	0,08	0,06	0,04	-

$\varphi = 0.7$  in accordance with Table 6, since  $\lambda = l_0/h = 12$  Flexibility of masonry and  $\alpha = 500$  by results of the survey

$\varphi_c = 0.18$  in accordance with Table 6, since  $\lambda = l_0/(h - 2 * e_0) = 40$  Flexibility of masonry under the condition of partial work of the section and  $\alpha = 500$  by results of the survey

Therefore, the obtained values can be substituted into the formula 7 However, to determine the actual bearing capacity of the masonry, it is

necessary to introduce a correction reduction factor  $m_k$ , which is determined in consequence of the survey and after the designation of the technical condition category to the selected element, as described in chapters 2.3.2 and 3.2.1.

For the masonry under consideration, the coefficient of decrease in the bearing capacity  $m_k = 0.5$ , by reason of the absence of significant cracks, but the presence of irregularities in geometry, as well as by internal and external conditions.

$$N = m_g * \varphi_1 * \omega * R * A_c * m_k = 1 * 0.45 * 1.35 * 1.1MPa * 0.148m^2 * 0.5 = 50.146kN \quad (9)$$

$$N < F_{tot} = 52.65kN$$

Strengthening is necessary.

#### 4.4.2 Specification of the strengthening

Strengthening is carried out by the device of two-sided concrete casing with installation of additional transverse steel rods. The thickness of the concrete layer for design reasons is taken as 60mm from concrete class B12.5, except for places of the greatest deformation, where it is necessary to extend the section to the general level. This will ensure a sufficient increase in the cross-sectional area and the integration of the structures elements into one. To improve the adhesion of the concrete coating to the existing wall, as well as to prevent crumbling of this coating, a steel mesh reinforcement is made from rods with a diameter of 5 mm and a cell of 125 × 125 cm. To ensure the work of reinforced concrete layer vertical rods are installed over the steel mesh. Rods are made of steel of grade A-I with a diameter of 8 mm every 100 cm and longitudinal reinforcement cross-links with a diameter of 16 mm through 100 cm in height and length of the wall.

The bearing capacity of a wall strengthened by reinforcement can be determined based on the sum of the work of the longitudinal reinforcement and the masonry itself.

$$N_f = \psi * \varphi * m_g * m_k * R * A + \psi * \varphi * \eta * \frac{2.8 * \mu}{1 + 2 * \mu} * \frac{R_{sw}}{100} * A \quad (10)$$

$\psi$  – Empirical coefficient, taking into account eccentricity  $\eta = 1 - 2 * \frac{e_0}{h} = 0.3$

$\eta$  – Empirical coefficient, taking into account eccentricity  $\eta = 1 - 4 * \frac{e_0}{h} = -0.4$

$\mu$  – Percentage of reinforcement; Since the rod diameter was taken as  $\varnothing 16$  mm:  $\mu = \pi * (8mm)^2 / 1m^2 = 0.0002$

$R_{sw}$  – Design resistance of shear reinforcement; Since the steel of class for all rod, used as reinforcement is A-I:  $R_{sw} = 150MPa$

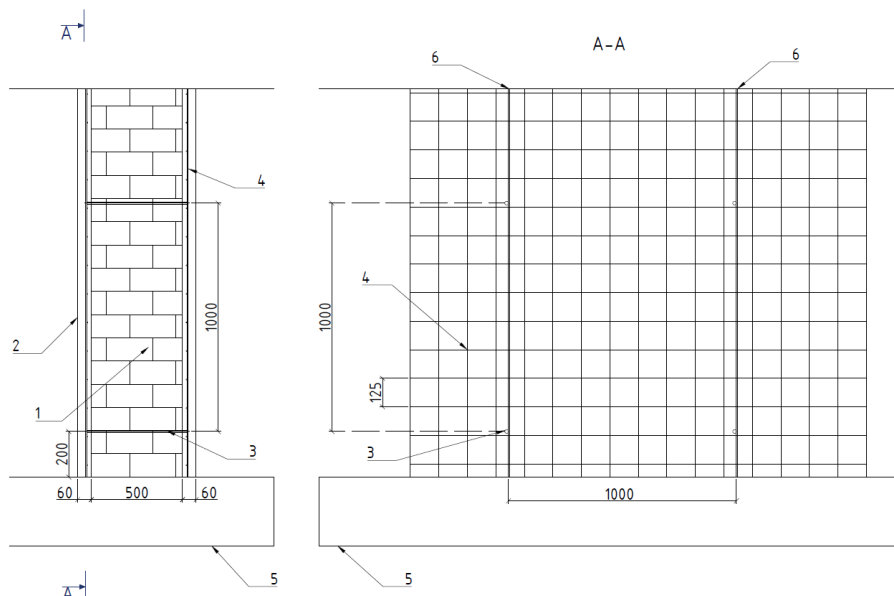

Figure 29 Reinforced concrete collar scheme: 1 - reinforced wall; 2 – concrete layer of class B12; 3 - longitudinal cross-links  $\varnothing 16A-I$  mm through 1000 mm; 4 - steel mesh  $\varnothing 5A-I$  mm with a cell of  $125 \times 125$  mm; 5 - foundation; 6 - vertical reinforcement  $2\varnothing 8A-I$  mm through 1000 mm;

It is also necessary to take into account the concrete covering and the steel mesh when calculating the final value of the maximum possible loading of reinforced masonry. However, it is not possible to completely transfer the force directly to the cage, because of the way in which the structures element are combined. Wherefore a condition load effect factor of the reinforced concrete  $\gamma_b$  is introduced.

In this case, the gain does not have a lower and upper pinch, then  $\gamma_b = 0.35$ . And when determining the reinforcement, only cross-links are taken into account [SP 63.13330.2012].

$$N_f = \gamma_b * R_b * A_{cm} + R_{cs} * A_{sw} \quad (11)$$

$R_b$  – Design strength of concrete coating for centric compression; For the concrete of the chosen brand  $R_{cm} = 7.5MPa$

$A_{sw}$  – Reinforcement area receiving the load; Since the vertical reinforcement is  $8\varnothing 5$  mm and  $2\varnothing 8$  mm for every 100 cm of wall length, area is calculated as  $A_{sw} = 8(2.5mm)^2 * \pi + 2(4mm)^2 * \pi = 2.576cm^2$

$R_{CS}$  – Design resistance of longitudinal reinforcement. Since it is accepted from the steel of class A-I and there is no directly transfer of load to the cage, the resistance value is adopted  
 $R_{CS} = 43MPa$

$A_{cm}$  – Area of concrete per 1 m2.  $A_{cm} = 2 * 60mm * 1m = 0.6m^2$

Summarizing, the ultimate load-bearing capacity can be found as the sum of the combined action of the masonry compression strength (10), which contain longitudinal reinforcement, with the work of the concrete layer reinforced with steel rod mesh (11):

$$N_f = \psi * \varphi * (m_g * m_k * R + \eta * \frac{2.8\mu}{1 + 2\mu} * \frac{R_{sw}}{100}) * A + \quad (12)$$

$$+ \gamma_b * R_b * A_{cm} + R_{CS} * A_{sw} = 95.84kN$$

$$N_f > F_{tot} = 52.65kN$$

The condition is ensured

#### 4.5 Calculation of the column strengthening by pre-stressed struts

Several factors influenced the choice of the method for the column strengthening: the impossibility of a significant increase in cross-sections with a significant increase in the load on the column and the need to combine work of strengthening with other types of work, namely, roof insulation and the installation of a ventilation system, followed by installation of the floating ceiling. The reasons for this overlap are described above. Thus, the idea of reinforcements of the column by creating concrete collar was abandoned, in view of the long time for concrete setting and for acquiring the necessary physical properties. It should be noted that although the method of reinforcement reviewed in the first case has many advantages, most important of which is the price of materials and works. However, in a particular case, losses, as a result of downtime of car wash works in conjunction with the costs of implementing such a reinforcement, exceeded the costs of materials and assembly work on the installation of steel struts.

For these reasons, a method of strengthening through installation of pre-stressed struts was chosen, which combines several of the methods described in 3.2.1. Moreover, to consider the application of design schemes of similar strengthening, a column with the largest load area and the largest damage was chosen, which is also described in Table 4.1

##### 4.5.1 Actual bearing capacity of the column

###### 1. Load summary

The load area for this particular column was calculated counting that the average distance of a row of columns is 6.4 m, respectively, the load distribution between the columns is equally divided. Therefore, to find the load area it is necessary to take a square with dimensions  $L = B = 6.3 \text{ m}$

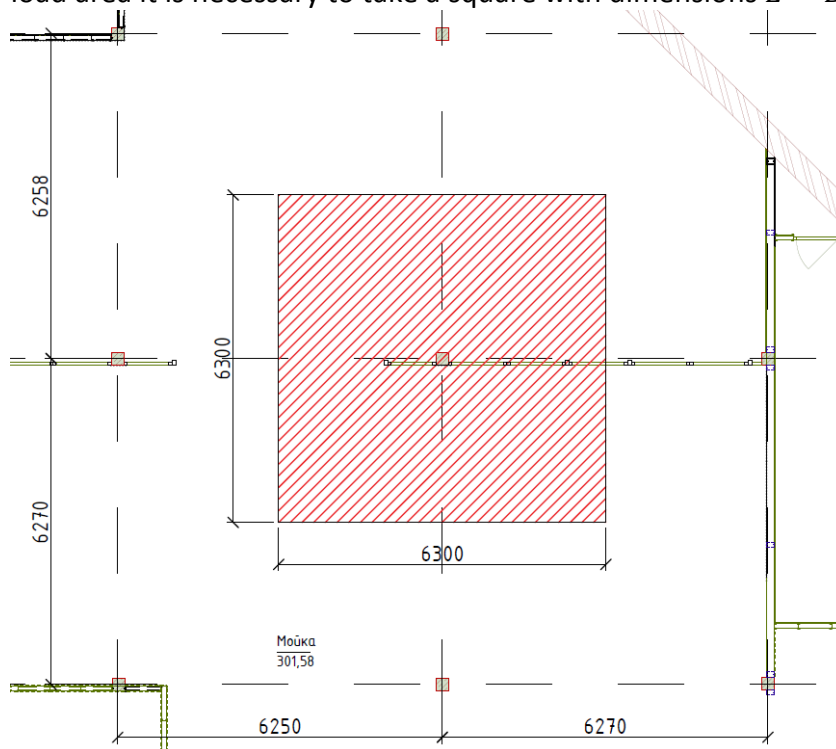

Figure 30. Loading area per section of the column

The value of the total load on the wall is found as the sum of the dead loads and permanently acting load within a given area, as well as loads from work carried out on this section of the roof.

$$F_{tot} = (1.1 * F_c + 1.4 * F_s + 1.4 * F_w) = 370.52kN \quad (13)$$

$F_c$  – Concentrated load from the roof  $F_c = P * B * L = 251.64kN$

$F_s$  – Concentrated snow load  $F_s = S_0 * B * L = 71.44kN$

$F_w$  – Concentrated wind load  $F_w = \omega * B * L = -4.45kN$

## 2. Load-bearing capacity of the column

The load-bearing capacity of the masonry is determined as in the case considered above, only under the condition of centric compression:

$$N = m_g * \varphi * R * A \quad (14)$$

$m_g$  – Coefficient that takes into account the effect of the duration of the load, which for a given masonry  $m_g = 1$



$\varphi$  – In accordance with Table 4.3  $\varphi = 0.6$ , since  $\lambda = l_0/h = 16$   
Flexibility of masonry under the condition of partial work of the section and  $\alpha = 500$  by results of the survey

$R$  – Value of design strength of the masonry based on survey results is  
 $R = 1.1MPa$

$A$  – Area of the compressed section with a rectangular stress diagram determined from the condition that centre of gravity coincides with the point of application of the calculated longitudinal force  $A = b^2 = 0.151m^2$

$m_k$  – For the column the coefficient of decrease in the bearing capacity  
 $m_k = 0.65$ , by reason of the absence of significant cracks.

$$N = 1 * 0.45 * 1.35 * 1.1MPa * 0.148m^2 * 0.5 = 42.12kN \quad (15)$$

$$N < F_{tot} = 328.4kN$$

Strengthening is necessary

#### 4.5.2 Specification of the strengthening

##### 1. Necessary cross-sectional area of struts

In this method of strengthening, the angle bars appear for the struts, which compress the structure from all sides. However, before the struts are placed in the design position a cut and a slight bend are made in the leg of angle in the middle of their height (Figure 31). Then the preliminary tension is created by crackdown the draw bolts, which leads to the straightening of the struts, and after pre-stressing, the corners of the struts must fit tightly against the body of the reinforced element. The joint work of the struts is ensured by welding metal strap with a step equal to the minimum cross-sectional dimension of the reinforced element. After welding the strap, the bolts are removed, and the weakened sections of the struts are strengthened by additional metal plates. Therefore, the welding of additional slats compensates the weakening of the cross section of the angle bar at the cut-out site.

The effectiveness of the inclusion of struts in the work is achieved when creating in them a pre-stressing voltage up to 80 MPa, which is fully ensured by elongation when straightening angle bars.

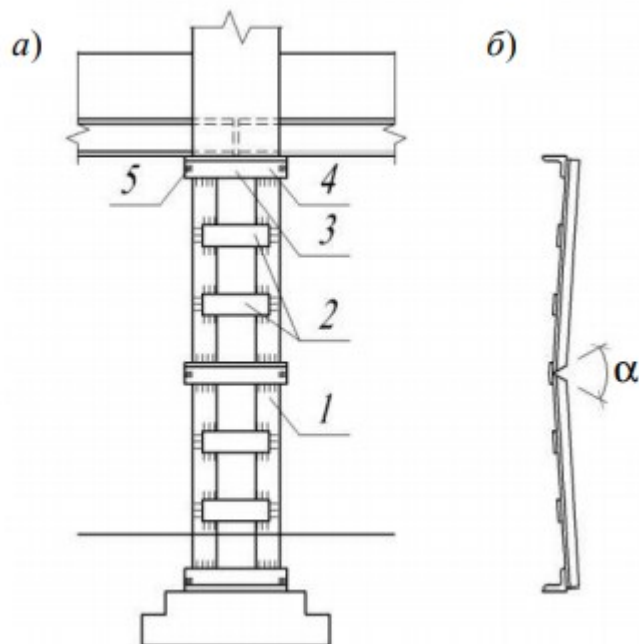

Figure 31. Reinforcement by pre-stressed struts: a – struts assembly; b - the design of the struts before the assembly: 1 – angle bars; 2 – strap; 3 – tension bar, 4 – supporting angle bars; 5 - the bolts

Since most of the load will be transferred to struts, it is first necessary to determine its geometric parameters. It means that if the class of rolled steel is adopted as C245, the total area of the struts can be found from the conditions of the stability of elements of a continuous section under central compression:

$$A_{\Sigma s} \geq \frac{N_0}{\varphi_s * R_y * \gamma_s} = 16.89 \text{ cm}^2 \quad (16)$$

$N_0$  – Amount of load, perceived by the angle bars, which is

$$N_0 = F_{tot} - N = 328.4 \text{ kN}$$

$\varphi_s$  – For first approximation flexibility of steel  $\varphi_s = 0.9$  Later, this value must be corrected in accordance with the obtained values of the cross sections

$R_y$  – Design strength of the steel; For chosen class  $R_y = 240 \text{ MPa}$

$\gamma_s$  – Condition load effect factor  $\gamma_s = 0.9$

Consequently, if each strut consists of two angle bars located on opposite sides of the column, then the cross-sectional area of one particular corner can be found as  $A_s = A_{\Sigma s} / 4 = 4.3 \text{ cm}^2$

However, in the range of rolled steel there are no angle bars with a such cross-sectional area, it means that in this situation it is possible either to order angle bars with individual sizes, or to take the nearest available with

rounding upward. Since the second method is more economical and expedient, the parameters of the adopted angle bars:

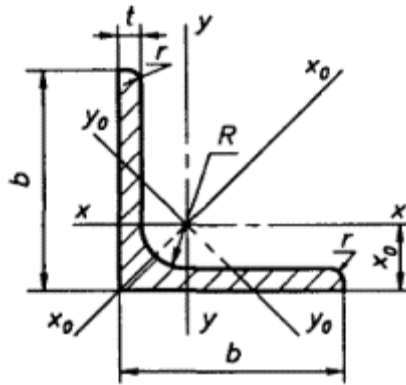

$I_x = 11.2cm^2$  – Axial moment of inertia

$W_x = 3.15cm^2$  – Section modulus

$t = 5mm$  – Depth of web

$x_0 = 1.42mm$

$i_x = 1.53mm$  – Section radius of inertia

$A_s = 4.8mm$  – Cross-section area

## 2. Calculation of strut's straps

In addition to the struts, straps also take part in the structural strength, as they hold the structure together and cause its combined action. Hence, it follows that it is necessary to calculate the shear force, and the moment that bends the strap in its plane [SP 63.13330.2012].

Shear force	Moment bending in its plane
$F_q = Q_s * \frac{s}{b_s} * \frac{1}{2} = 4.16kN$ (17)	$M_q = Q_s * \frac{s}{2} * \frac{1}{2} = 0.59kNm$ (18)

$Q_s$  – The conventional shear force accounts for the struts assembly located in one plane. Moreover, for a similar type of section, the conventional shear force  $Q_s$  can be determined from the empirical formula:

$$Q_s = 7.15 * 10^{-6} * \left( 2330 - \frac{E}{R_y} \right) * \frac{N_0}{\varphi_s} = 3.905kN \quad (19)$$

$s$  – Distance between centers of the straps; For compressed elements, the maximum distance  $s = 600mm \leq 40 * i_x = 612mm$

$b_s$  – Distance between axes of the struts.  $b_s = h + 2 * t - 2 * z_0 = 281.6mm$

Thus, it can find the required moment of resistance of the strip  $W_q = M_q/R_y = 4.9cm^3$  on which base the characteristics of the strap are determined.

So, taking on the design requirements the strap with height  $h_{pl} = 100mm$  and thickness of  $b_{pl} = 6mm$ , the condition is also observed.

$$W_{pl} = (b_{pl} * h_{pl}^2)/6 = 10cm^3 \geq W_q$$

## 3. Check of welded joint

For design reasons, the weld joint is adopted  $K_f = 5mm$ , but for reliability it is necessary to check the cross-sections of the fillet welds for strength (for weld metal or for the melting boundary) and to determine which one is crucial importance [SP 63.13330.2012].

Weld metal	Melting boundary
$R_{wf} = 180 \text{ MPa}$	$R_{un} = 370 \text{ MPa}$
$\beta_f = 0.7$	$\beta_z = 1$
$R_{wf} * \beta_f = 126 \text{ MPa}$	$R_{wz} * \beta_z = 0.45R_{un} * \beta_z = 167 \text{ MPa}$

Therefore, a check on the weld metal is necessary.

Strength of the weld could be determined as

$$R = R_{wf} * \gamma_{wf} * \gamma_c * \beta_f = 113.4 \text{ MPa} \quad (15)$$

$R_{wf}$  – Design shear strength of the weld;  $R_{wf} = 180 \text{ MPa}$

$\gamma_{wf}$  – Condition load effect factor  $\gamma_{wf} = 1$

$\gamma_c$  – Service factor; since the structure is a composite section  $\gamma_c = 0.9$

The total stress is determined by the resultant stress from the shear force and bending moment:

$$\sigma = \sqrt{\tau^2 + \sigma^2} = 70.78 \text{ MPa} \quad (16)$$

$\tau$  – Stress in the weld from the shear force:  $\tau = F_q / (K_f * h_{pl})$

$\sigma$  – Stress in the weld from the bending moment:  $\sigma = M_q / (K_f * h_{pl}^2 / 6)$

Therefore, by comparing the effective stress in the weld and the maximum strength, it is possible to determine the adequacy of the selected characteristics:

$$R = 113 \text{ MPa} \geq \sigma = 70 \text{ MPa}$$

The condition is ensured

## 5 CONCLUSION

On the example of reconstruction works carried out at the site of the current car wash complex, it was shown that there is a need for some regulations for holding such events. Difficulties, which any reconstruction project has to deal with, require both preparedness, having in mind the overall risk assessment or the experience of past projects, and the ability to respond to the changing circumstances immediately. The absence of a long-term plan and incompleteness of the approach, which satisfies only the interests of the present day, can lead, after a certain time, to the impossibility of carrying out subsequent reconstruction without demolition of the building.

Thus, it follows from all of the above that it is possible to achieve the tasks assigned by the customer and the project itself only with the maintenance of a certain sequence of work and with the correctly perceptions of each of them implementation. Moreover, the second requires much more immersion in the process. As the ability to give a correct assessment of the condition of a building and the analysis of possible mistakes and difficulties, which may arise during the implementation phase of the project and the operation of the building, gives a huge advantage in finances and time. In turn, this ability depends on the knowledge of the environment of the project being implemented and the work of its materials and structures.

There is also a need in global practices trends monitoring. What is meant by the correct use of traditional methods, with the gradual introduction of new methods and materials with the higher physical and mechanical properties and that are less expensive and easier to handle. Knowledge and skilful application of methods used in the reconstruction of buildings is a guarantee of high-quality performance of works and further operation of buildings in accordance with its functional purpose.

## REFERENCES

Aita, D., Pedemonte, O., Williams, K. (2015). *Masonry Structures: Between Mechanics and Architecture*

Antakov, A.B. (2014). *Durability of the stone layings reinforced by composite grids*

Bad'in, G.M., Sychev, S.A. (2013). *Sovremennye tekhnologii stroitel'stva i rekonstruktsii zdaniy*

Blog of the construction company «Rosmaks-Servis». (n.d.). Strengthening of building structures. Retrieved 10 January 2018 from <http://rosmaks.com.ua/blog/usilenie-stroitelnyih-konstruktsiy/>

Brooks, J. J. (2015). *Concrete and Masonry Movements*

Building Age Maps. Retrieved 5 December 2017 from <http://msk.mercator.ru/>

Building Code Requirements and Specification for Masonry Structures Developed by the Masonry Standards Joint Committee (MSJC)

Chanakya, A. (2009). *Design of Structural Elements: Third Edition Concrete, steelwork, masonry and timber designs to British Standards and Eurocodes*

Ciblac, T., Morel, J. (2014). *Sustainable Masonry Stability and Behavior of Structures*

DictionaryOfConstruction.com. (n.d.). Retrieved 15 December 2017 from <http://www.dictionaryofconstruction.com/>

Dobromislov, A.N. (2001). *Rekomendatsii po otsenke nadezhnosti stroitel'nykh konstruktsiy zdaniy i sooruzheniy po vneshnim priznakam*

Gorse, C., Johnston, D., Pritchard, M. (2005). *A Dictionary of Construction, Surveying and Civil Engineering*.

Grozdov, V.T. (2005). *Defekty stroitel'nykh konstruktsiy i ikh posledstviya*

Guchkin, I.S. (2001). *Diagnostika povrezhdeniy i vosstanovlenie ekspluatatsionnykh kachestv konstruktsiy*

Hendry, A.W., Sinha, B.P., Davies, S.R. (2004). *Design of masonry structures: Third edition of Load Bearing Brickwork Design*

Holding company "Kompozit". (n.d.). External reinforcement system. Retrieved 10 January 2018 from <http://www.hccomposite.com/catalog/54/>

Ivliev, E. A. (2007). *Elektroosmoticheskoe osushenie sten i fundamentov zdaniy*

Kabantsev, O.V. (2016). *Plastic deformation and fracture of masonry under biaxial stresses*

Kabantsev, O.V. (2016). *Nauchnye osnovy strukturnoy teorii kamennoy kladki dlya otsenki predel'nykh sostoyaniy kamennykh konstruksiy seysmostoykikh zdaniy*

Kashevarova, G.G., Ivanov, M.L. (2012). *Natural and numerical experiments aimed at building the stress-strain brickwork*

Masayasu, O. (2016). *Innovative AE and NDT Techniques for On-Site Measurement of Concrete and Masonry Structures*

Nesterenko, Y.A., Yur'yev, A.V. (2007) *Covremennye metody usileniya zhelezobetonnykh konstruksiy. XVI Student International Extramural Scientific and Practical Conference "Youth Academic Forum: Technical and Mathematical Sciences"*. Retrieved 2 February 2018 from <http://nauchforum.ru/node/4304>

Nostroy. (2013). *Vosstanovlenie i povyshenie nesushchey sposobnosti kirpichnykh sten*

Peñal, F. (2004). *Role of the tension strength in the collapse mechanism of unreinforced brick masonry constructions*

Sarhat, S.R. (2016). *The Size Effect and Strain Effect in Reinforced Masonry*

Shagin, A.L. (1991). *Rekonstruktsiya zdaniy i sooruzheniy*

Shikhov, A.N. (2016). *Rekonstruktsiya zdaniy i sooruzheniy*

Shilin, A.A., Pshenichnyy, V.A., Kartuzov, D.V. (2007). *Usilenie zhelezobetonnykh konstruksiy kompozitsionnymi materialami*

Smoljanovic, H. (2017). *Numerical analysis of 3d dry-stone masonry structures by combined finite-discrete element method*

Smorchkov, A.A., Kereb, S.A., Orlov, D.A., Baranovsky, K.O. (2012). *Testing the technical condition of maintained building structures*

Soil map of Moscow. Retrieved 15 January 2018 from [http://www.etomesto.ru/map-eco\\_pochva/](http://www.etomesto.ru/map-eco_pochva/)

Sokolov, V.A. (2011). *Otsenka tekhnicheskogo sostoyaniya stroitel'nykh konstruksiy na zdaniy na osnove mnogoarochnogo veroyatnostnogo analiza*

Sokolov, V.A. (2011). *Building systems technical condition assessment based on the multilevel probabilistic analysis*

SP 13-102-2003 Pravila obsledovaniya nesushchikh stroitel'nykh konstruktsiy zdaniy i sooruzheniy

SP 15.13330.2012 Masonry and reinforced masonry structures

SP 16.13330.2011 Steel structures

SP 20.13330.2016 Loads and actions

SP 63.13330.2012 Concrete and reinforced concrete structures

SP 70.13330.2012 Load-bearing and separating constructions

Startsev, S.A., Sundukova, A.A. (2014). *Reinforcement of brick masonry with composite materials and screw-in anchors*

Stewart, E. (2005). *Historic building reconstruction since 1877: the creation of popular images of the age of transition*

Stukach, V.N., Sharapov, I.V. (2016). *Modern methods of strengthening of load-bearing structures of buildings and constructions under reconstruction as a tool for resource conservation*

Travin, O.V. (2004). *Novye konstruktsionnye materialy*

Travin, V.I. (2013). *Kapital'nyy remont i rekonstruktsiya zhilykh i obshchestvennykh zdaniy: uchebnoe posobie dlya vuzov.*

Ulybin, A.V., Startsev, S.A., Zubkov, S.V. (2013). *Humidity control in the inspection of masonry structures*

VSN 53-86. (1988). Pravila otsenki fizicheskogo iznosa zhilykh zdaniy

Zigler, R., Witzany, J. (2016). *Stress State Analysis and Failure Mechanisms of Masonry Columns Reinforced with FRP under Concentric Compressive Load*

Zolotozubov, D.G., Bezgodov, M.A. (2014). *Rekonstruktsiya zdaniy i sooruzheniy*

Zubkov, S.V., Ulybin, A.V., Fedotov, S.D. (2015). *Assessment of mechanical properties of brick masonry by flat-jack method*



ROOF SECTIONAL ELEVATION

Разрез А-А

Разрез Б-Б

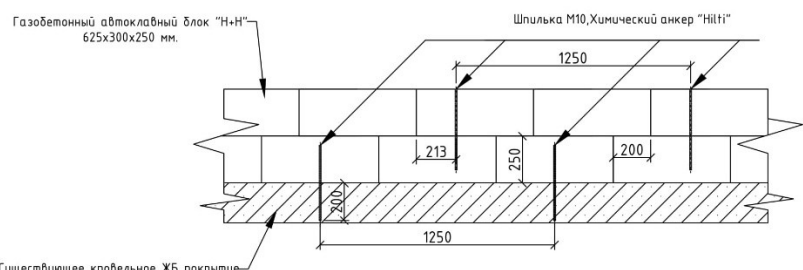
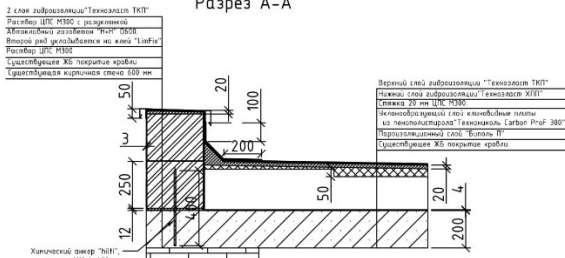

Примечание:  
 -перед укладкой пароизоляционного слоя заделать неровности раствором ЦПС М150 и обработать грунтовкой праймером "Технониколь".  
 -швы пароизоляционных полотнищ сплавить.  
 -на вертикальную поверхность парапета завести пароизоляцию на 150 мм.  
 -нахлест пароизоляционных полотнищ в боковых швах 80 мм, в торцевых швах 150 мм. Торцевые швы располагать в разбежку.  
 -армирование стяжки производить картами Врз 150x150 с нахлестом в одну ячейку. Места нахлеста стяжки вязальной проволокой.  
 -маячки после твердения раствора вынуть и образовавшиеся полосы зачеканить ЦПС М300.  
 -при устройстве стяжки ЦПС необходимо выполнять температурно-усадочные швы с шагом в двух направлениях не более 6 м. Накрывать полосами гидроизоляции посыпкой вниз шириной 150 мм.  
 -у водосборной воронки необходимо выполнить понижение уровня в радиусе 0.5 м, на 20 мм.  
 -нанести праймер "Технониколь №01" на всю поверхность укладки гидроизоляционного ковра.  
 -наклонная поверхность бортика формируется с размерами катетов 100x100 из ЦПС М300.  
 -укладку рулонов гидроизоляции производить с пониженных участков. Нахлест рулонов в боковых швах мм, в торцевых швах 150 мм.  
 -швы нижнего и верхнего слоя гидроизоляции выполнить в разбежку.

Местный вид А

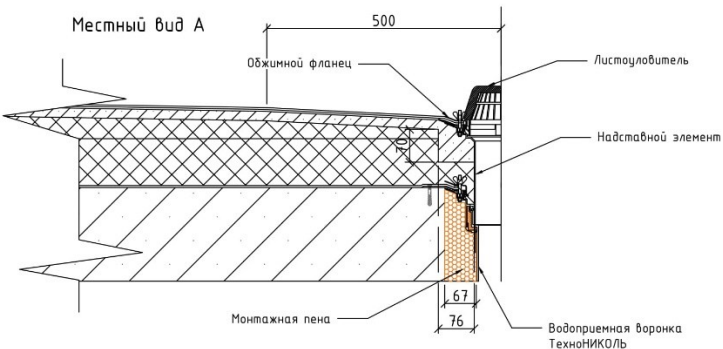

					022-05/17			
					Архитектурные решения			
Изм	Код	Лист	И док	Подпись	Дата	Стадия	Лист	Листов
ГИП					08/17			
Разработал					08/17	Р	12	19
Исполнил								
Н.контр								
					План кровли			
					ООО "Карэл Групп"			

Имя, № паян. Папн, дата. Взам, шифер, №. Имя, № дубл. Папн, и дата.



## DESIGN RESISTANCE OF THE MASONRY TO COMPRESSION

Марка кирпича или камня	Расчетные сопротивления $R$ , МПа, сжатию кладки из кирпича всех видов и керамических камней со щелевидными вертикальными пустотами шириной до 12 мм при высоте ряда кладки 50-150 мм на тяжелых растворах									
	при марке раствора								при прочности раствора	
	200	150	100	75	50	25	10	4	0,2	нулевой
300	3,9	3,6	3,3	3,0	2,8	2,5	2,2	1,8	1,7	1,5
250	3,6	3,3	3,0	2,8	2,5	2,2	1,9	1,6	1,5	1,3
200	3,2	3,0	2,7	2,5	2,2	1,8	1,6	1,4	1,3	1,0
150	2,6	2,4	2,2	2,0	1,8	1,5	1,3	1,2	1,0	0,8
125	-	2,2	2,0	1,9	1,7	1,4	1,2	1,1	0,9	0,7
100	-	2,0	1,8	1,7	1,5	1,3	1,0	0,9	0,8	0,6
75	-	-	1,5	1,4	1,3	1,1	0,9	0,7	0,6	0,5
50	-	-	-	1,1	1,0	0,9	0,7	0,6	0,5	0,35
35	-	-	-	0,9	0,8	0,7	0,6	0,45	0,4	0,25

## ELASTIC RESPONSE OF THE MASONRY

Вид кладки	Упругая характеристика $\alpha$				
	при марках раствора			при прочности раствора	
	25-200	10	4	0,2	нулевой
1 Из крупных блоков, изготовленных из тяжелого и крупнопористого бетона на тяжелых заполнителях и из тяжелого природного камня ( $\gamma \geq 1800 \text{ кг/м}^3$ )	1500	1000	750	750	500
2 Из камней, изготовленных из тяжелого бетона, тяжелых природных камней и бута	1500	1000	750	500	350
3 Из крупных блоков, изготовленных из бетона на пористых заполнителях и поризованного, крупнопористого бетона на легких заполнителях, плотного силикатного бетона и из легкого природного камня	1000	750	500	500	350
4 Из крупных блоков, изготовленных из ячеистых бетонов:					
автоклавных	750	750	500	500	350
неавтоклавных	500	500	350	350	350
5 Из камней, изготовленных из ячеистых бетонов:					
автоклавных	750	500	350	350	200
неавтоклавных	500	350	200	200	200
6 Из керамических камней (кроме крупноформатных)	1200	1000	750	500	350
7 Из кирпича керамического пластического прессования полнотелого и пустотелого, из пустотелых силикатных камней, из камней, изготовленных из бетона на пористых заполнителях и поризованного, из легких природных камней	1000	750	500	350	200
8 Из кирпича силикатного полнотелого и пустотелого	750	500	350	350	200
9 Из кирпича керамического полусухого прессования полнотелого и пустотелого	500	500	350	350	200