



VAASAN AMMATTIKORKEAKOULU  
UNIVERSITY OF APPLIED SCIENCES

Heidi Leskinen

Platforms, walkways, stairs, ladders and  
Railings -  
Design Handbook

School of Technology  
2018

VAASAN AMMATTIKORKEAKOULU  
UNIVERSITY OF APPLIED SCIENCES  
Rakennustekniikka

## ABSTRACT

Author	Heidi Leskinen
Title	Platforms, Walkways, Stairs, Ladders and Railings – Design Handbook
Year	2018
Language	English
Pages	32 + 1 Appendix
Name of Supervisor	Marja Naaranoja

---

Companies develop different handbooks for different subjects giving thus strict guidelines within employees design. The client of the thesis Citec Oy Ab did not have an updated guide for safety standards and therefore employees had to search standards from many different sources for the employee to be able to design according to the regulations. Citec needed employees to have an easy access to information that they will need in their work and avert unnecessary knowledge hoarding which takes time from actual work.

The aim of the thesis was to create an updated handbook that combines all the latest safety regulations and standards between Europe and the US and gives the designer strict guidelines for the design. In this public version of the thesis Canadian and Australian standards have been brought to the comparison to provide added information on practices around the world.

The thesis deals with safety regulations for platforms, walkways, stairs, ladders and railings, but does not take a stand on the emergency exit or fire regulations, for example.

---

Keywords	Safety regulations, platforms, walkways, stairs, ladders and railings
----------	---

## TIIVISTELMÄ

Tekijä	Heidi Leskinen
Opinnäytetyön nimi	Tasanteet, Kulkutiet, Portaat, Tikkaat ja Kaiteet – Suunnittelukäsikirja
Vuosi	2018
Kieli	Englanti
Sivumäärä	32 + 1 liite
Ohjaaja	Marja Naaranoja

---

Yritykset kehittävät erilaisia käsikirjoja eri aiheille antaen näin työntekijöille tarkat ohjeet joiden sisällä suunnitella. Työn tilaajalla Citec Oy Ab:llä ei ollut voimassa olevaa ohjetta turvallisuusstandardeista ja voidakseen suunnitella säädöksiin mukaisesti suunnittelijan täytyi etsiä standardeja monista eri lähteistä. Citec halusi työntekijöillensä helpon pääsyn työssä tarvitsemaansa tietoon ja eliminoida turhan tiedon keräyksen, joka vie aikaa itse työltä.

Opinnäytetyön tavoitteena oli tehdä päivitetty käsikirja, joka yhdistää viimeisimmät turvallisuussäädökset ja -standardit Euroopan ja Yhdysvaltojen välillä, sekä antaa suunnittelijalle erilliset ja täsmälliset ohjeet joiden mukaan suunnitella. Tässä julkisessa versiossa vertailuun on tuotu myös Kanadan ja Australian turvallisuusmääräykset, sekä standardit antamaan lisätietoa käytännöistä maailmanlaajuisesti.

Opinnäytetyö käsittää turvallisuusmääräykset tasanteille, kulkuteille, portaille, tikkaile ja kaiteille, mutta ei ota kantaa esimerkiksi hätäpoistumisteiden määräykseen tai paloturvallisuuteen.

# CONTENTS

## ABSTRACT

## TIIVISTELMÄ

1	INTRODUCTION .....	7
1.1	General Information.....	7
1.2	Background and Aims of the Thesis.....	7
1.2.1	Citec Oy Ab .....	7
1.2.2	Citec Finland .....	8
1.2.3	Civil Engineering in Citec.....	8
2	COMPARING REGULATIONS FROM EUROPE, CANADA, US AND AUSTRALIA .....	9
2.1	Factors Affecting the Design .....	9
2.1.1	Standards .....	9
2.1.2	Location.....	9
2.1.3	Escape Routes .....	10
2.2	Walkways and Platforms .....	10
	Safe and ergonomic location.....	10
	Basic requirements and dimensions.....	10
2.3	Railing.....	12
2.3.1	When Required?.....	12
2.3.2	Dimensions of Railing .....	13
2.3.3	Toe Board.....	16
2.4	Stairs .....	16
2.4.1	When Required?.....	16
2.4.2	Dimensions of Stairs .....	17
2.4.3	Stair Railing .....	20
2.5	Ladders.....	23
2.5.1	General Requirements .....	23
2.5.2	Dimensions of ladder .....	23
	Spacing between the rungs.....	23
	Clearances .....	24

2.5.3	Fall Protection .....	26
	Dimension of safety cage .....	27
3	PROCESS OF THE DESIGN HANDBOOK UPDATE.....	29
3.1	Starting the Update .....	29
3.2	Appearance .....	29
3.3	Update .....	29
4	SUMMARY AND CONCLUSIONS .....	30
	REFERENCES.....	31
	APPENDICES	

## LIST OF FIGURES AND TABLES

<b>Figure 1.</b> Access gauge on walkways /redrawn 5/ .....	12
<b>Figure 2.</b> Rails guideline by combining the dimensions from the different guidelines /6, 14, 15, redraw 6/ .....	15
<b>Figure 3.</b> Vertical distance for handrail /14, figure 5.3/ .....	15
<b>Figure 4.</b> Key parts of stairs /6, Figure 1/.....	19
<b>Figure 5.</b> Guardrail and handrail requirements for different handrail systems /6, 12, 14, redrawn 11/.....	22
<b>Figure 6.</b> Ladder clearances and dimensions /7, 8, redrawn 7/ .....	25
<b>Figure 7.</b> Dimensions of safety cage /6, 11, 12, 13, 14, redrawn 7/.....	28
<b>Table 1.</b> Handrail requirements.....	20

## LIST OF APPENDICES

<b>APPENDIX 1.</b> Platforms, Walkways, Stairs, Ladders and Railings - Design Handbook	
--	--

# **1 INTRODUCTION**

## **1.1 General Information**

This thesis studies how to use the varying safety regulations in the USA and Europe when designing. The end result of this research work is a confidential design handbook that supports the work of mechanical and civil designers at Citec. The Citec handbook will be used as a guideline when designing platforms, walkways, stairs, ladders and railings and it combines safety regulations from OSHA (Occupational Safety and Health Administration) and EN (European Standards) in to one "Citec design directive".

This public part of the thesis gives only some examples of the regulations and design guidelines regarding platforms, walkways, stairs, ladders and railings; and compares their regulations of Europa, the US, Australia, and Canada.

## **1.2 Background and Aims of the Thesis**

The design of platforms, walkways, stairs, ladders and railings is regulated all over the world. The aim of this work is to introduce some design guidelines, and to which extent they are similar and how they vary in Europe, US, Australia and Canada.

The introduced similarities and differences give only a glance to the guidelines and this document cannot be used as a design guideline.

### **1.2.1 Citec Oy Ab**

The original guideline is done to Citec Oy Ab that is a technical engineering company that works in energy, oil & gas, process plants, buildings, transportation and machinery & equipment sectors. The company was founded by two engineers Rune Westergård and Rolf Berg in Vaasa Finland in 1984. At first Citec was a small engineering company but in early 1990's it started rapidly to expand as new lines of business emerged.

Citec was divided into two separate corporations in 1993 Citec Environmental and 2001 Citec Information, but later in 2008 the Citec Environmental became part of Citec Engineering Oy Ab.

Today Citec employs 1300 specialists in 11 countries all over the world and has made projects in over 120 countries and full scope engineering in more than 1000 power plants. The turnover in year 2015 was 77 million EUR. Today other founder of the company Rune Westergård owns 20% of the company and the rest of it is owned by different shareholders and Citec management. /1, 2, 3/

### **1.2.2 Citec Finland**

Citec Finland has 6 offices located all over but the head office for Citec Oy Ab is still located in Vaasa where the company was originally founded. The number of personnel altogether in Finland offices is approximately 500. Citec Finland has over 30 years of experience in engineering and documentation services and it is constantly communicating between customers, project teams in Finland and other Citec countries. /1/

### **1.2.3 Civil Engineering in Citec**

Citec Engineering offers professional engineering and design, among other things, for plant-, product- and building engineering. Complete civil design includes project coordination and quality assurance. Clients include contractors, building owners and private corporations. Citec provides services for industrial projects within process industry, refinery, energy, oil & gas, and pulp & paper related plants and buildings, but also for commercial buildings in private and public building projects, such as shopping centers, hospitals, sports arenas, office buildings and parking houses. /1/



## **2 COMPARING REGULATIONS FROM EUROPE, CANADA, US AND AUSTRALIA**

### **2.1 Factors Affecting the Design**

The regulations and standards in the Europe, Canada, US and Australia are presented and as a synthesis design directive is given for each structure dealt with

#### **2.1.1 Standards**

This handbook compares US (OSHA), European (ISO EN), Canadian (OSH) and Australian (AS) safety regulations and combines them into one design directive that gives a design guideline that fulfills all the regulations from these different standards. All the regulations are specified separately and then combined as one design directive that the designer follows when designing.

#### **2.1.2 Location**

Every country or state has their own and often varying detailed level safety regulations that give the requirements for design.

In the US states have often their own OSHA standards which supplement the federal OSHA standards. When the state has its own OSHA requirements concerning the matter that is to be designed, the state OSHA shall be used, because the state requirements are always at least as safe as the federal requirements and in most cases safer.

Australian federal AS standards are used in every state in the country.

If there is no state requirement for a particular issue, the federal standards shall be satisfied. In every case it is important to check both the actual state and the federal standards.

### 2.1.3 Escape Routes

Escape routes are not included in this design handbook. All countries in Europe have their own national fire safety regulations for escape routes and for that reason escape routes shall always conform to the national fire safety regulations.

## 2.2 Walkways and Platforms

- Safe and ergonomic location

EUROPE: Walkways and working platforms shall be located as far away from hazard areas and emission of harmful materials. /5, 4.2.1/

CANADA: For every working platform must be provided a safe access and /17, 13.7/

US: No similar requirements in federal OSHA but check the actual state OSHA standards.

AUSTRALIA: No similar requirements.

Design directive: Walkways and working platforms shall be located away from emission and any materials which are likely to cause slipping. Working platforms shall be located in a way that it is possible for person to work in ergonomic position. Preferably between 500 mm and 1700 mm above the surface of the platform.

- Basic requirements and dimensions

EUROPE: Width  $w$ , minimum 800 mm. May be reduced to 600 mm when stairs are used less than 2 hours/day and not more than 30 days/year. When the height of a stairs is 1500mm and it is made with single flight, the width may be reduced from 600 mm to 500 mm. If the stairway is used by multiple people simultaneously, the clear width  $w$  shall be increased to 1000 mm.

The minimum head height,  $h$  on working platforms and walkways shall be 2100 mm but it may be reduced to 1900 mm if an obstacle is crossing the walkway at the head-height. /5, 4.2.2/

CANADA: Walkways must be at least 600 mm wide and made with slip resistant material or other ways provide traction to prevent slipping. Where possible equipped with a guardrail system. /18, 121(1) and (2)/

US: No similar requirements in federal OSHA but check the actual state OSHA standards.

AUSTRALIA: The minimum head room,  $h$  on working platforms and walkways shall be 2000 mm. Walkways must be at least 600 mm wide /14, 3.15 and 5.1.3 (a)/

Design directive: Figure 1 gives an illustration of the special requirements for platforms and walkways. The minimum head height,  $h$  on working platforms and walkways shall be 2100 mm but it may be reduced to 1900 mm if an obstacle is crossing the walkway at the head-height.

The clear width,  $w$  shall be more than 800 mm on walkways. When the walkway is used by several persons simultaneously, the width shall be increased to 1000 mm. See Figure 1.

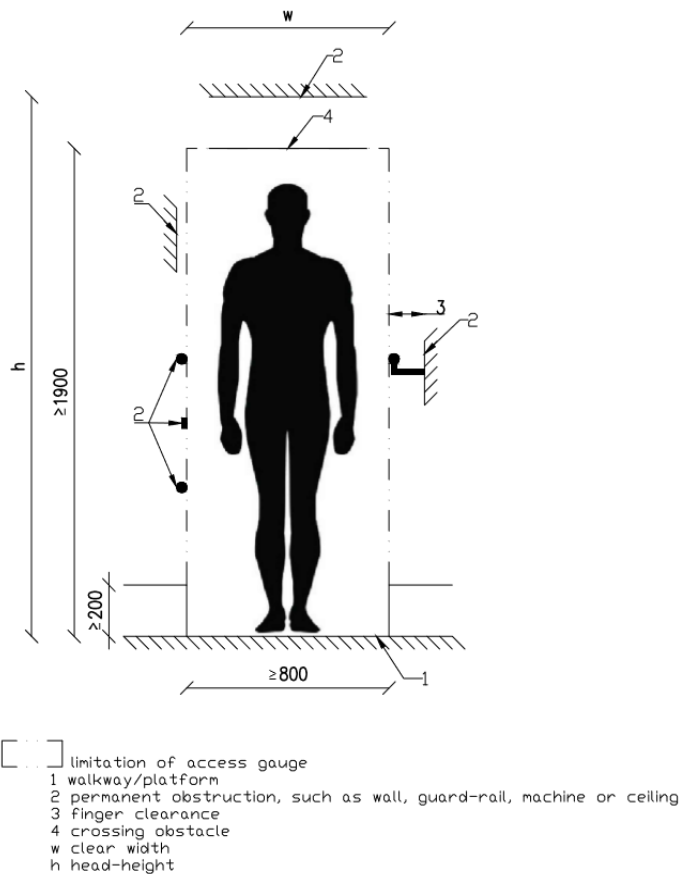

**Figure 1.** Access gauge on walkways /redrawn 5/

## 2.3 Railing

### 2.3.1 When Required?

EUROPE: A guard-rail shall be fitted when the height of possible fall exceeds 500 mm. /6, 7.1.1/

CANADA: A guardrail system shall be installed in every open side of the platform/structure where the height of possible fall exceeds 1200 mm. /15, 2.5/

US: On a walking- working surface that is more than 1.2m above the lower level guardrail-, safety net- or personal fall protection system shall be provided on all unprotected sides or edges. /11, (b)(1)(i)/

AUSTRALIA: A guardrail system shall be installed in every open side of the platform/landing. /14, 4.4/

Design directive: When the height of fall exceeds 500mm, a guardrail shall be fitted.

### **2.3.2 Dimensions of Railing**

EUROPE: The guardrail shall be more than 1100 mm in height and it shall be as uniform as possible through the length of the rail. The handrail of the guardrail system shall be not exceed more than 1100 mm at height.

When the ends of the segments do not have rounding, the clear space between the stanchions shall not be more than 120 mm and not less than 50 mm

With rounding the clear space shall not exceed 80 mm and shall be at least 50 mm in width.

The mid rail shall be placed between the top rail and walking surface and the clear space of the handrail and the mid rail and the mid rail and the toe plate shall not exceed 500mm /6, 7.1.2 – 7.1.4 and 7.1.8/

CANADA: The height of the top rail of the guardrail shall be not less than 900 mm and not more than 1100 mm. The intermediate rail shall be placed at approximately midway between the walking surface and top of the top rail and vertical supporting posts shall be spaced not more than 3 meters apart. /15, 2.12 and 3.8/

US: The height of the guardrail system measured from the walking-working surface to top of the top rail shall be 107 cm  $\pm$ 8cm. /12, (b)(1)/

AUSTRALIA: The height of the guardrail system shall not be less than 900 mm. When the height of a possible fall is significant or when wind forces may occur, the height of the guardrail system shall be exceeded to 1000 mm minimum. The clearance between the lower side of the top rail and top side of the intermediate rail and lower side of the intermediate rail and top of the toe board shall be 450 mm minimum. /14, 5.6.2, 6.2.1.1, C 6.2.1.1, 6.2.1.2 (b) and figure 6.1/

When the top rail of the guardrail system acts as a handrail, the maximum height of the guardrail system is 1100mm and the minimum height 900 mm. If only a handrail is provided, the handrail shall be of the height between 900 mm and 1100 mm. /14, 5.6.2 and 6.2.1.1/

The maximum gap between guardrail elements shall be between 25 mm and 50 mm /14, 6.2/

Design directive: The maximum clear space between horizontal rails (top rail, intermediate rail and toe board) shall be 450 mm.

When the top rail of the guardrail system acts as a handrail, the maximum height of the guardrail system is 1100mm. When a separate handrail is provided, the guardrail shall extend at a height of minimum 1100mm and the handrail between 900mm and 1100 mm. See Figure 2 and 3.

When the ends of the segments do not have rounding, the clear space between the stanchions shall not be more than 120 mm and not less than 50 mm

With rounding the clear space shall not exceed 80 mm and shall be at least 50 mm in width. See Figure 2.

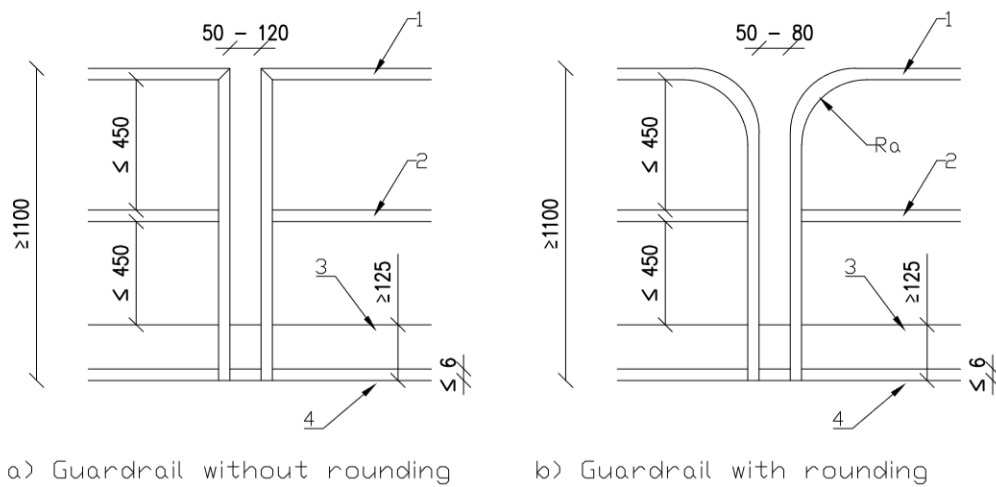

- 1 Top rail
- 2 Intermediate rail / midrail
- 3 Toe board
- 4 Walking and working surface

**Figure 2.** Rails guideline by combining the dimensions from the different guidelines /6, 14, 15, redraw 6/

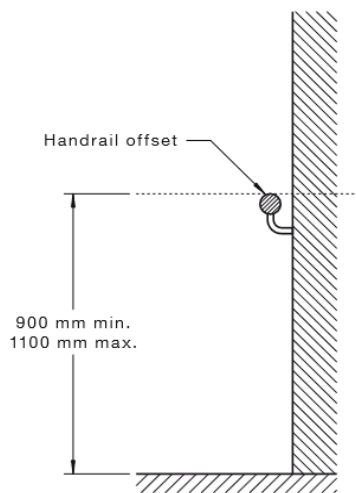

**Figure 3.** Vertical distance for handrail /14, figure 5.3/

### **2.3.3 Toe Board**

EUROPE: The toe board shall be a minimum of 100 mm at vertical height and shall be placed a maximum of 12 mm from the walking surface. /6, 7.1.6/

CANADA: When there is a possibility of tools or objects falling into the lower level, a toe board shall be fitted. The toe board shall extend a minimum of 125 mm from the walking surface to the top of the toe board. When the tools and other objects are piled higher than the top of the toe board so that toe board does not prevent them from falling, a solid or mesh panel shall be fitted from the walking surface to a height at minimum of 450 mm. /15, 2.13/

US: The minimum vertical height of the toe board is 9cm measured from the walking-working surface to the top of the toe board. The clear space above the walking working surface shall not exceed 0.6 cm. /12, (k)(1)(ii) and (k)(1)(iii)/

AUSTRALIA: The toe board shall extend a minimum of 100 mm from the walking/working surface to the top of the toe board. The maximum clearance between the walking/working surface and toe board is 10 mm. /14, 5.5 and figure 6.1/

Design directive: The toe board shall extend a minimum of 125 mm from the walking working surface to the top of the toe board and shall be placed a maximum of 6 mm from the edge of the platform. See Figure 2.

## **2.4 Stairs**

### **2.4.1 When Required?**

EUROPE: Stairs are recommended to use on the angle of pitch not less than 30° and not more than 38°, but allowed slope is between 20° and 45°. /4, 3.3 and 6.4/

CANADA: When the height between two levels is more than 450 mm and where an employee is required to move from one level to another a stairway, ramp or ladder shall be fitted. /15, 2.7/



US: When the travel between levels is regular and routine, a standard stair shall be provided to give easy access from one walking-working surface to another. Standards stairs are installed on an angel not less than 30° and not more than 50°. /9, (b)(7) and (c)(1)/

AUSTRALIA: Standard stairs are installed on an angel not less than 20° and not more than 45°. When the distance between levels is more than 300 mm and not more than 450 mm, one stair shall be provided. /14, 2.2(c) and 3.1.4/

Design directive: Standard stairs are required when the height from walking-working platform to another exceeds 450 mm and the travel is regular and routine. The recommended slope for stairway is between 30° and 38° but slope up to 45° is allowed.

#### **2.4.2 Dimensions of Stairs**

EUROPE: The rise,  $h$ , and going,  $g$ , shall meet the formula  $600 \leq g + 2h \leq 660$  and the going shall be between 210 mm and 310 mm. /6, 5.1-5.2/

The width,  $w$ , minimum 800 mm. May be reduced to 600 mm when the stairs are used less than 2 hours/day and not more than 30 days/year. When the height of a stair is 1500mm and it is made with single flight, the width may be reduced from 600 mm to 500 mm. If the stairway is used by multiple people simultaneously, the clear width,  $w$ , shall be increased to 1000 mm. /6, 5.8/

Head-height,  $e$ , minimum 2300 mm. /6, 5.6/

Clearance,  $c$ , minimum 1900 mm. /6, 5.7/

The climbing height,  $H$ , may not exceed 4000 mm in case of a single straight flight. When multiple flights, the height of individual flight shall not exceed 3000 mm. The landing is mandatory after every flight when there is continuum to another flight. /6, 5.9/

The length of the landing,  $l$ , shall be equal or greater than the width of the stair but at least 800 mm /6, 5.9/

The overlap,  $r$ , of the step shall be maximum of 10 mm /6, 5.3/

CANADA: Rise,  $h$ , maximum 180 mm and minimum 125 mm. The stairs shall have a uniform rise height. Between the tallest and shortest riser shall be not more than 10 mm difference in height. One riser shall have  $\pm 5$  mm tolerance in height. /16, 16. slide 4 and 18, slide 2/

Going,  $g$ , maximum no limit and minimum 280 mm. The stairs shall have a uniform tread depth. Between the deepest and shortest tread shall be not more than 10 mm difference in height. One tread shall have  $\pm 5$  mm tolerance in depth. / 16, 16. slide 4//

Head-height,  $e$ , minimum 2050 mm/16, 10. slide 2/

The overlap,  $r$ , of the step shall be  $\geq 25$  mm /16, 11. slide 1/

US: Rise,  $h$ , maximum 24 cm. /9, (c)(2)/

Tread depth,  $t$ , minimum 24 cm. /9, (c)(3)/

With,  $w$ , fixed stairways shall have a minimum width of 56 cm. /9, (b)(5)(ii)/

Head-height,  $e$ , minimum 203 cm. /9, (b)(2)/

The length of the landing,  $l$ , shall be at least the width of the stair and at least 76cm in depth. /9, (b)(4) (b)(5)(ii)/

AUSTRALIA: Rise,  $h$ , shall meet the formula  $540 \leq (2h + g) \leq 700$  but be a minimum of 130 mm and maximum of 225 mm. /14, Figure 7.2/

Tread depth,  $t$ , minimum 185 mm. /14, Figure 7.2/

The length of the landing,  $l$ , shall be at least the width of the stair and at least 600 mm in depth. /14, 7.2.4 /

Design directive: The climbing height,  $H$ , may not exceed 4000 mm in case of a single straight flight. When multiple flights, the height of individual flight shall not

exceed 3000 mm. The landing is mandatory after every flight when there is continuum to another flight.

Going,  $g$ , min 280 mm.

Head-height,  $e$ , minimum 2050 mm

Rise,  $h$ , max 180 mm and minimum 130 mm.

The length of the landing,  $l$ , shall be equal or greater than the width of the stair but at least 800 mm.

Overlap,  $r$ ,  $\geq 25$  mm.

Width,  $w$ , minimum 800 mm.

Tread depth,  $t$ , minimum 24 cm

Clearance,  $c$ , minimum 1900 mm

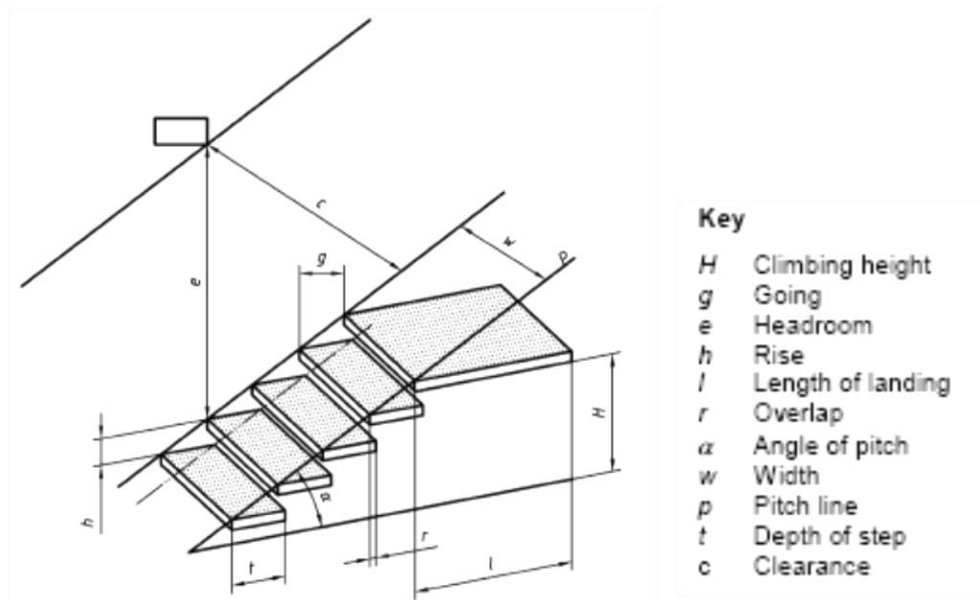

**Figure 4.** Key parts of stairs /6, Figure 1/

### 2.4.3 Stair Railing

EUROPE: When the height of the climb exceeds 500 mm, a guardrail system shall be installed. The vertical height of the handrail shall be a minimum of 900 mm and a maximum of 1000 mm above the nosing of the stair. Above the walking level on the landing the minimum height of handrail shall be not less than 1100 mm /6, 7.2.1.1 and 7.2.1.4/

CANADA: The height of handrails shall be between 865 mm and 965 mm. When the stairs exceed at height more than 2200 mm, an intermediate rail shall be fitted. /16, 21. Part 9/

US: The stairs that have a minimum of 3 treads and 4 risers shall be equipped with a handrail and the stair rail systems according to Table 1.

**Table 1.** Handrail requirements

<b>Width of stair</b>	<b>Enclosed side</b>	<b>One open side</b>	<b>Two open sides</b>
< 1.1 m	At least one handrail	One stair rail system with handrail on open side.	One stair rail system each open side.
1.1 m to 2.2 m	One handrail on each enclosed side	One Stair rail system with handrail on open side and one handrail on enclosed side.	One stair rail system with handrail on each open side.
> 2.2 m	One handrail on each enclosed side and one intermedi-	One stair rail system with handrail on open side, one handrail on enclosed	One stair rail system with handrail on each open side and one in-

	ate handrail located in the middle of the stair	side, and one intermediate handrail located in the middle of the stair.	intermediate handrail located in the middle of the stair.
--	---	---	---

The vertical height of handrails stays between 76 and 97 cm measured from the top surface of the handrail to the leading edge of the stair tread. /12, (f)(1)(i)/

The stair rail system shall be not less than 107 cm measured from the top surface of the top rails to the leading edge of the stair tread. /12, (f)(1)(ii)(B)/

When the top rail of the stair rail system serves also as a handrail, the vertical height of the top rail may stay between 91 cm and 97 cm. /12, (f)(1)(iii)/

AUSTRALIA: The clearance between the edge of the walking working platform and the guardrail system shall not exceed 100 mm. The height of the guardrail system shall not be less than 900 mm. When the height of a possible fall is significant or when wind forces may occur, the height of the guardrail system shall be exceeded to 1000 mm minimum. /14, 6.2.1.1, 5.4.1 and figure 6.1/

Design directive: A stair rail system may be fitted when the height of the climb exceeds 500 mm. The handrail shall be at height between 900 mm and 965 mm and the guardrail between 910 and 965 mm when the top rail of the guardrail system works as a handrail. When a handrail is provided separately in the guardrail system, the guardrail system shall be at height minimum 1100 mm. See Figure 5.

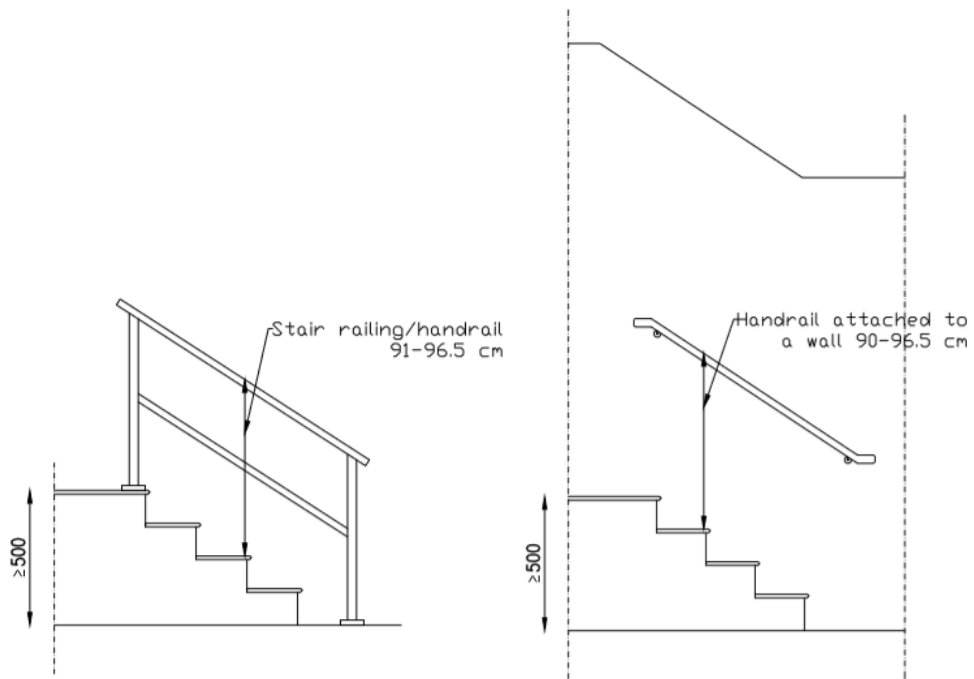

a) Stair rail system, when top rail works as a handrail      b) Handrail attached to a wall et cetera

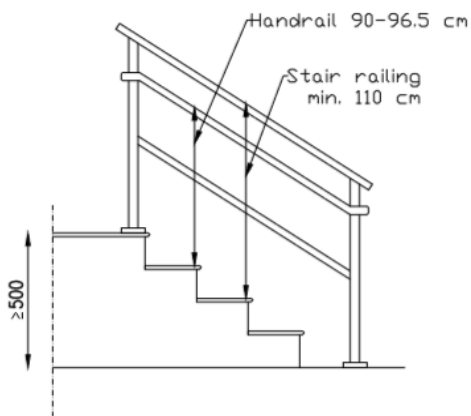

c) Handrail in stair rail system

**Figure 5.** Guardrail and handrail requirements for different handrail systems /6, 12, 14, redrawn 11/

## 2.5 Ladders

### 2.5.1 General Requirements

EUROPE: The ladder should be designed primarily with two stiles, only in exceptional cases for example when a fall arrester is required or when there is not enough space for two stile ladders, a ladder with one stile may be used. The angle of pitch of fixed ladders should be between 75° and 90°. /7, 4.1.1 and G, 3.1/

CANADA: When the height between two levels is more than 450 mm and where an employee is required to move from one level to another stairway, a ramp or ladder shall be fitted /15, 2.7/

US: Ladder steps, rungs and cleats shall be parallel and uniformly spaced. The angle of pitch of fixed ladders should be between 60° and 90°. /9, Figure 10 and Q, (b)(1)/

AUSTRALIA: Normally rung type ladders shall be in an angle of 70° and 90° but the recommendation for ladders with one stile is between 70° and 90° and ladder with a single rung is between 85° and 90°. /14, 2.2 (e)-(f) and Figure 2.1/

Design directive: The ladder should be designed primarily with two stiles. Only in exceptional cases for e.g. when a fall arrester is required or when there is not enough space for two stile ladder, a ladder with one stile may be used. The angle of pitch of ladders should be between 75° and 90°.

### 2.5.2 Dimensions of ladder

- Spacing between the rungs

EUROPE: Spacing between rungs shall be uniform with a distance between 225 mm and 300 mm, with exemption the first rung at the departure area that have spacing at least 100 mm and a maximum of 400 mm. /7, 5.2.2.2/

CANADA: Ladder rungs are spaced maximum of 300 mm apart. /19, Table 8.1/

US: Ladder rungs are spaced uniformly not less than 250 mm and not more than 360 mm apart, with exception elevator shafts and telecommunication towers that have different requirements. /8, (b) (1)/

AUSTRALIA: Ladders that extend at a height of 1 m or more the rungs shall be spaced between 250 mm and 300 mm /14, 7.4.3.2 (a)/

Design directive: Ladder rungs are spaced uniformly and parallel with a distance of 250 mm-300 mm apart. The first rung at the departure area shall be at distance 100 mm-400 mm from the walking level. See Figure 5.

- Clearances

EUROPE: The space between any permanent obstruction in front of the ladder shall be at least 650 mm measured from the front of the rungs. This distance may be reduced to 600 mm when obstacles such as pipes or trays cross.

Behind the ladder the clear space should be at least 200 mm with exception when obstacles such as pipes cross behind the ladder, then the clear space shall be reduced to 150 mm.

The spacing behind the ladder measured from behind the rungs shall be at least 75 mm, except for the upper rung which can be between 60 mm and 75 mm /7, 4.1.3/

CANADA: The minimum distance at back side of the ladder shall be minimum of 178 mm but may be reduced to 39 mm when unavoidable objects encounter. /18, Table 8.1/

US: The minimum clearance on a climbing side of the ladder is 76 cm measured from the centerline of the ladder steps or rungs to the nearest object. If unavoidable obstructions encounter, the clearance may be reduced to 61 cm minimum.

Behind of the ladder the minimum clearance to the nearest object shall be a minimum of 18 cm except of elevator pit ladders with a minimum clearance of 11 cm. /8, (d)(13)(ii) and (d)(2)/



AUSTRALIA: The minimum clearance on a climbing side of the ladder is 750 mm measured from the nosing of the rung to the nearest object. The minimum distance at back side of the ladder shall be a minimum of 200 mm. /14, 7.4.5 (a-b)

Design directive: The clearance on the climbing side of the ladder shall be a minimum of 760 mm and behind the ladder 200 mm measured from front side of the ladder. If unavoidable objects encounter on the back side of the ladder, the minimum clearance may be reduced to 150 mm and on the climbing side of the ladder 610 mm.

The spacing behind the ladder measured from behind the rungs shall be at least 75 mm, except for the upper rung which can be between 60 mm and 75 mm. See Figure 6.

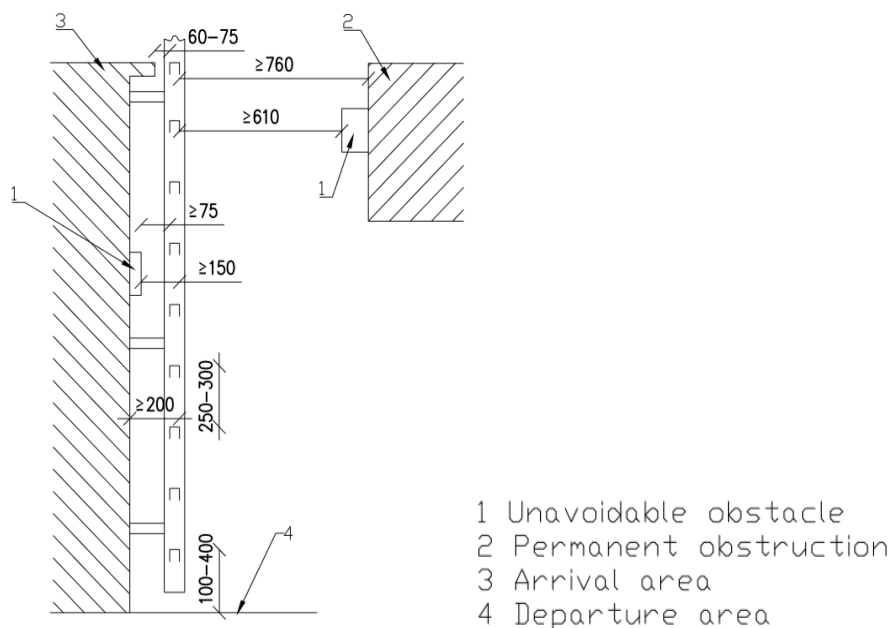

**Figure 6.** Ladder clearances and dimensions /7, 8, redrawn 7/

### 2.5.3 Fall Protection

EUROPE: Safety cages are required when the total distance, H, from the walking working surface to another is between 3000 mm and 10 000 mm and the ladder is designed as a single flight ladder. Ladder systems with staggered flights with a maximum height of the flight, h, of 6 000 mm, are equipped with a safety cage.

When the total height of the ladder systems, H, exceeds 10 000 mm the ladder is protected with a safety cage when the ladder is designed as staggered flights with a maximum height of the flight, h, of not more than 6 000 mm. Otherwise, a fall arrester shall be used.

The fall arrester is intended to be used only by well-trained users and a combination of both safety cage and fall arrester shall not be applied. /7, 4.3.2 & 4.3.3/

CANADA: A safety cage shall be provided when the height of the ladder is 6.5 m or more. With elevated access, the safety cage shall be provided when the top of the ladder exceeds more than 5 m above the ground level, floor or roof even when the ladder climb is less than 5 m. /18, Table 8.1 and 20, 3.4/

US: Fixed ladders are always equipped with a personal fall arrest system or a ladder safety system when the ladder extends more than 24 feet (7.3 m) above a lower level. A cage may be used together with a fall arrest system or a ladder safety system only if it does not interfere with the operation of the personal fall arrest system. /11, (b)(9)(iv)/

AUSTRALIA: A safety cage shall be provided if a person could fall more than 6 m from a lower level. If the use of a safety cage is not possible, a personal fall arrest system shall be provided. /14, 7.4.7/

Design directive: Fixed ladders shall always be equipped with a personal fall protection system or a ladder safety system when the ladder extends more than 7.6 m above the ground level. A safety cage shall be used together with personal fall protection system only if it does not interfere with the operation of the personal fall protection system.

If the height of the ladder is between 3-7.6 m, a safety cage on its own will give enough protection for a falling person and in that case personal fall protection system is not required.

- Dimension of safety cage

EUROPE: The diameter of the safety cage shall be between 650-800 mm. Safety cage components shall be horizontally a maximum of 300 mm and vertically 1500 mm apart but so that the empty spaces are in any case  $\leq 0,40 \text{ m}^2$ . The first hoop shall be at distance 2200-3000 mm measured from departure area. / 7, 5.5.1.2, Annex B Figure B.1/

CANADA: The diameter of the safety cage shall be between 680-760 mm measured from centerline of the rungs. The first hoop of the safety cage shall be at distance 2200 mm maximum. Ladder fasteners shall be at a maximum distance of 3000 mm apart. The safety cage shall extend at least 900 mm above the landing area. /19, 3.4 and figures 3-4/

US: The size of the safety cage shall be at least 686 mm wide and all safety cage components shall be horizontally maximum 240 mm and vertically 1200 mm apart. The first hoop shall be at height between 2100 and 2400 mm. The safety cage shall extend at least 1100 mm above the landing area. /12, Figure D-15 and 13, (a)(20)(iii), (a)(20)(viii), (a)(20)(i)/

AUSTRALIA: The safety cage shall be semicircular. The width of the safety cage shall be 700 mm and the distance at back of the ladder 750 mm. Safety cage components shall be horizontally maximum 150 mm and vertically 2000 mm apart. . The first hoop shall be at a distance of 2000-2200 mm. The safety cage shall extend 1000 mm above the landing area. /14, 7.4.7 and Figure 7.7 and 7.8

Design directive: The size of the safety cage shall be circular and the diameter between 700 mm and 750 mm. Safety cage components shall be horizontally maximum 150 mm and vertically 1200 mm apart. The first hoop shall be at a distance of 2100-2200 mm measured from the departure area. The safety cage shall extend 1100 mm above the landing area. See Figure 7.

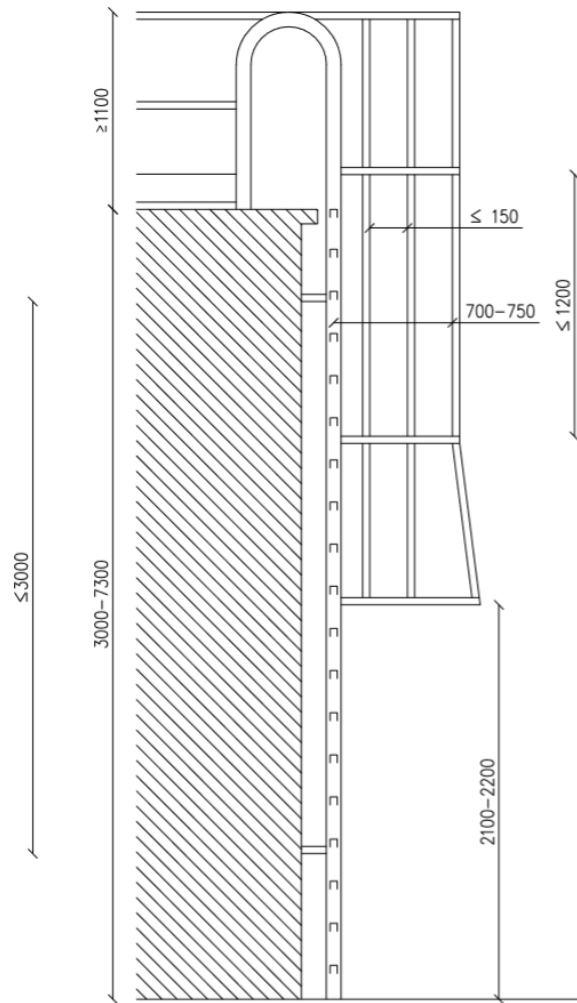

**Figure 7.** Dimensions of safety cage /6, 11, 12, 13, 14, redrawn 7/

### **3 PROCESS OF THE DESIGN HANDBOOK UPDATE**

#### **3.1 Starting the Update**

The process of updating the confidential design handbook started by gathering the old standards that were used when the handbook was originally prepared and finding the new and most recent versions of those standards. When comparing the old and new standards it was possible to update the handbook without changing its original look and readability and it was easier to know what the original author wanted to describe in different chapters.

For the public version of thesis Canadian and Australian standards were gathered in addition, to give more comparison to EN and OSHA standards.

#### **3.2 Appearance**

Every headline in the handbook contains an EN and OSHA standard that regulates the particular issue which is separated in every headline. In addition, Citec combines its own “Citec design directive” from these two standards and it was added after the standard text. This design directive always uses the stricter requirements between EN and OSHA and clarifies the purpose of particular standard to the designer.

The same style is also used in the public version thesis where standards from Europe, Canada, US and Australia are showed separately and then combined the strictest regulations into a design directive.

#### **3.3 Update**

Every standard text in the handbook was checked and updated according to the new standard of particular issue. If differences were found between the old and new standard, the handbook was updated according to the new regulations.

Regulations in EN and OSHA standards have changed radically in most parts and the standards have become stricter. Almost every chapter has changed due to the added and tighter regulations.

## 4 SUMMARY AND CONCLUSIONS

This thesis was necessary because the handbook for platforms, walkways, stairs, ladders and railings that Citec Oy Ab use in their mechanical and civil design was badly outdated and not useful anymore. This caused extra time loss for designers because regulations were not at easy access and Citec did not have a strict design guideline for designers to follow. The purpose of this thesis subject was to create an updated version of Citecs design handbook and to have the same design guidelines to all designers and thus get uniform designs despite of the designer.

The aims of this thesis were achieved by studying the standards from the US and Europe that dealt the subject and then comparing them together. All information and standards are latest and come from reliable sources.

In the study it was realized that Australian standards have more similarities with European standards than with Canada and the US. The appearances and methods of standards are similar in Australia and Europe, but standards between these two differ almost in everything. Canada and the US use the same kind of appearance in their regulations and have very similar standards in many subjects.

During the writing of the thesis Citec provided additional guidance and information about Citec guidelines and way of working. The goals of the thesis were achieved and now the handbook has all the latest standards and information for Citec employees to use.

## REFERENCES

- /1/ Citec Oy Ab webpage. Accessed 01.02.2018  
<https://www.citec.com/about-us/>.
- /2/ Citec insider - web portal of the company. Accessed 01.02.2018
- /3/ Company economics. Accessed 01.02.2018 <https://www.finder.fi/Insin%C3%B6%C3%B6ritoimistoja+suunnittelutoimistoja/Citec+Oy+Ab+Vaasa/Vaasa/yhteystiedot/398316>.
- /4/ SFS-EN ISO 14122-1:2016, Standard
- /5/ SFS-EN ISO 14122-2:2016, Standard
- /6/ SFS-EN ISO 14122-3:2016, Standard
- /7/ SFS-EN ISO 14122-4:2016, Standard
- /8/ US OSHA standard 1910.23. Ladders. Accessed 01.02.2018  
[https://www.osha.gov/pls/oshaweb/owadisp.show\\_document?p\\_table=STANDARDS&p\\_id=9715](https://www.osha.gov/pls/oshaweb/owadisp.show_document?p_table=STANDARDS&p_id=9715)
- /9/ US OSHA standard 1910.25. Stairway. Accessed 01.02.2018  
[https://www.osha.gov/pls/oshaweb/owadisp.show\\_document?p\\_table=STANDARDS&p\\_id=9717](https://www.osha.gov/pls/oshaweb/owadisp.show_document?p_table=STANDARDS&p_id=9717)
- /10/ US OSHA standard 1910.27. Scaffolds and rope descent systems. Accessed 01.02.2018 [https://www.osha.gov/pls/oshaweb/owadisp.show\\_document?p\\_table=STANDARDS&p\\_id=9719](https://www.osha.gov/pls/oshaweb/owadisp.show_document?p_table=STANDARDS&p_id=9719)
- /11/ US OSHA standard 1910.28. Duty to have fall protection and falling object protection. Accessed 01.02.2018 [https://www.osha.gov/pls/oshaweb/owadisp.show\\_document?p\\_table=STANDARDS&p\\_id=9720](https://www.osha.gov/pls/oshaweb/owadisp.show_document?p_table=STANDARDS&p_id=9720)
- /12/ US OSHA standard 1910.29. Fall protection systems and falling object protection-criteria and practices. Accessed 01.02.2018  
[https://www.osha.gov/pls/oshaweb/owadisp.show\\_document?p\\_table=STANDARDS&p\\_id=9721](https://www.osha.gov/pls/oshaweb/owadisp.show_document?p_table=STANDARDS&p_id=9721)
- /13/ US OSHA standard 1926.1053. Ladders. Accessed 01.02.2018  
[https://www.osha.gov/pls/oshaweb/owadisp.show\\_document?p\\_table=STANDARDS&p\\_id=10839](https://www.osha.gov/pls/oshaweb/owadisp.show_document?p_table=STANDARDS&p_id=10839)
- /14/ Australian standard, AS 1657—201

/15/ Canada Occupational Health and Safety Regulations (SOR/86-304). Accessed 01.02.2018 <http://laws.justice.gc.ca/eng/regulations/SOR-86-304/page-2.html>

/16/ National Research Council Canada.

Stairs, ramps, handrails and guards (NBC 2010, Parts 3 and 9). Accessed 01.02.2018 [https://www.nrc-cnrc.gc.ca/eng/solutions/advisory/codes\\_centre/presentations/2010/stairs.html](https://www.nrc-cnrc.gc.ca/eng/solutions/advisory/codes_centre/presentations/2010/stairs.html).

/17/ Work Safe BC. Part 13 Ladders, Scaffolds and Temporary Work Platforms. Accessed 01.02.2018 <https://www.worksafebc.com/en/law-policy/occupational-health-safety/searchable-ohs-regulation/ohs-regulation/part-13-ladders-scaffolds-and-temporary-work-platforms#2AE490AE8BBB46B0BB2982FD82CD54A6>.

/18/ Occupational Health and Safety Code 2009. Canada. Accessed 01.02.2018 [https://work.alberta.ca/documents/WHS-LEG\\_ohsc\\_p08.pdf](https://work.alberta.ca/documents/WHS-LEG_ohsc_p08.pdf).

/19/ Ontario ministry of labor. Fixed Access Ladders: Engineering Data Sheet 2–04, Canada. Accessed 01.02.2018 [https://www.labour.gov.on.ca/english/hs/pubs/eds2-4\\_ladders.php#bes](https://www.labour.gov.on.ca/english/hs/pubs/eds2-4_ladders.php#bes)



**APPENDIX 1.** Platforms, Walkways, Stairs, Ladders and Railings –  
Design Handbook. (CONFIDENTIAL)