

Saimaa University of Applied Sciences
Technology, Lappeenranta
Mechanical Engineering and Production Technology

Sergey Kulakov

**Industrial Automation. Conveyors in industrial
automation.
Automation project for Konepaja Astex Gear OY**

Thesis 2018

Abstract

Sergey Kulakov

Industrial Automation. Conveyors in industrial automation.

Automation project for Konepaja Astex Gear OY., 58 pages, 7 appendices

Saimaa University of Applied Sciences

Technology, Lappeenranta

Bachelor's degree in Mechanical Engineering and Production Technology

Thesis 2018

Instructors: Timo Eloranta [Saimaa University of Applied Sciences],
Esä Astikainen [Konepaja Astex Gear Oy].

The objective of the project was to design, build and program a conveyor line for an existing production unit in Konepaja Astex Gera Oy, Lappeenranta. The aim was to speed up the producing time for several types of parts by implementing automated driven conveyor line to keep the workpieces in same "0" position.

Data for this study was collected by personal observations, interviews, market research and comparison of the results of it. The data was collected and analyzed to identify the possible solutions in market and choosing the best available option.

As a result of the project a conveyor line was designed, acquired and installed to increase the productivity and reduce labor costs on pre-production stage.

Keywords: Industrial Automation, Conveyor lines, Sensory systems in conveying, Market research.

Table of contents

1	Introduction	5
1.1	Case company description	5
1.2	Aims, goals, research questions	6
1.3	Methodological issues	6
1.4	Limitations and delimitations	8
2	Industrial automation	9
2.1	Levels of automation	10
2.2	Industrial automation today	11
2.3	Advantages and disadvantages of industrial automation	12
2.4	Social impact of automation	14
3	Conveyors in industrial automation	15
3.1	Conveyors, structure and classification	16
3.2	Types of conveyors	17
3.2.1	Belt Conveyors	17
3.2.2	Bucket conveyors	19
3.2.3	Chain conveyors	20
3.2.4	Flight conveyors.....	21
3.2.5	Overhead conveyors.....	22
3.2.6	Roller conveyors and wheel conveyors	24
3.2.7	Screw conveyors	24
3.2.8	Slat conveyors	25
3.2.9	Vertical conveyors	27
3.3	Conveyors nowadays and future trends	28
4	Loads alignment and sensing in conveyors	29
4.1	Conveyor alignment systems	29
4.1.1	Conveyor structure alignment.....	30
4.1.2	Mechanical alignment.....	30
4.1.3	Alignment with a help of pushing device.....	31
4.2	Sensory Systems	31
4.2.1	Inductive sensors.....	32
4.2.2	Capacity sensors	33
4.2.3	Photoelectric	33
4.2.4	Ultrasonic.....	35
4.2.5	Contact sensors.....	35
5	Automation project for Konepaja Astex Gear OY. Design process	36
5.1	Preliminary structure design.....	38
5.2	Holding tool design	39
5.3	Detailed conveyor design.....	40
6	Market Research.....	40
6.1	SWOT analysis of automation project	41
6.2	Potential customers.....	43
7	Results	46
	Figures	48
	Tables	49
	References.....	50
	Appendices.....	52
	Appendix 1 A roundabout conveyor design.....	52
	Appendix 2 Spiral conveyor design.....	53
	Appendix 3 “Snake”-type conveyor design.....	54
	Appendix 4 Three types of holding devices.....	55

Appendix 5	Detailed conveyor design	56
Appendix 6	List of companies chosen for research.....	57
Appendix 7	Specification for a conveyor line.....	58

1 Introduction

Increase of production volumes and decrease of costs are connected to automation of industrial processes. Production automation is followed by increase of labor productivity, volume and quality of ready products, decrease of human participation in processes and intellectualization of human labor. High level of automation all over the country guarantees higher standard of living.

The basis of every production are different technological processes. Automation of this processes is one of the most difficult task on any production site. Modern automation systems include a combination of machines and mechanisms with electronic control or CPU and sensory system.

Modern stage of production development could be described as a transition to use latest technological decisions, the intention to achieve the highest operational performance of existing and future equipment, minimization of production loss. Achieving of this goal is possible only in case of implementing a process control system at any level of production and increasing the quality of already applied decisions.

Considering a production process as a single unit for automation it is important to state two main types of production sites: mass production, where the production range is limited but volumes are high, and wide range production of lower volumes.

1.1 Case company description

Case company Astex Oy was founded in 1988 by Ari Esa Astikainen in Ilottula, Lappeenranta. It was started as a one-man company when he bought a milling machine for hobby use. Nowadays Konepaja Astex Gear Oy is a medium-size production company with a year turnover for € 5,8 MM, year profit for € 0.13 MM and 25 employees.

Konepaja Astex Gear Oy is a machine shop working in the machining and assembling industry. It uses several production facilities, welding warehouse and outdoor storing facility.

The main specialization of the company is demanding machining of different materials: RST, HST, Hastelloy, castings, plastics, aluminum and copper alloys.

1.2 Aims, goals, research questions

The aim of the project was to speed up the producing time for several types of parts by implementing automated driven conveyor line to keep the workpieces in same "0" position.

The goals of the project were:

- to design conveyor line for an existing production unit. It would be important to take into consideration all possible designs and factors affecting the production site.
- to choose a solution from the existing on market. A research would be done for better understanding the market offers.

To achieve the listed aim and goals it would be necessary to answer the following research questions:

- What are the features of automation levels?
- What are the main conveyor types used nowadays? What are their benefits and problems?
- What are the affecting factors on the production site at Konepaja Astex Gear Oy?
- What are the possible designs of the structure to meet the requirements?
- Is there a fitting solution on the market?

After answering the stated research questions, it was possible to conduct the implementation of the automation unit on the facility of Konepaja Astex Gear OY.

1.3 Methodological issues

Three main methods of gathering information were used in this thesis:

1. Observations were held on a production site. Unstructured observation was used as a source of information because there were no stated variables to measure the working environment and processes.
2. Personal interviews with workers and process management involved. This qualitative research method was used to gain deep understanding of goals and targets of the desired automation project.
3. Marker research and analysis. Market research was done in two levels:

- Primary research – personal conversations and interviews were organized with companies involved in design and production of conveying systems.
- Secondary research – analysis of available information through Internet, books, magazines and already held researches.

For better understanding the market and business environment SWOT-analysis was held to reveal strengths, weaknesses, opportunities and threats of the project. This analysis showed both internal and external factors affecting on the company's behavior in a particular automation project.

SWOT analysis is used for strategic decision making in small- and medium-size companies for netter understanding companies Strength and Weaknesses from the inside environment and Opportunities and Threats coming from the outside environment (Figure 1). SWOT analysis is determining the grade of effectiveness of the company in the market. It is a brief analyzing tool of marketing information based on which it is concluded in what direction the organization should develop its business and is ultimately determined by the distribution of resources to the segments. A SWOT analysis gives a clear picture of the “situation” where it operates and helps to develop behavioral strategy. (Kotler & Keller 2006, p. 52.). The principle of this marketing tool is to deeply analyze each factor that could affect company's performance in the following projects or in daily activities.

SWOT analysis answers the following questions:

- Is the company following predominant strategy? If the strategy is now the most effective – what are the internal strength a company could apply for getting competitive advantage?
- How serious are the weaknesses and how strong they are able to impact the company's performance and change the circumstances? Which of the weaknesses should be taken firstly into consideration?
- Are there opportunities that would be gained by a company is case of successful implementation of a project?
- Which threats could have the most influence on company's performance and how to avoid them by changing operation strategy?

SWOT ANALYSIS



Figure 1. SWOT analysis (online.visual-paradigm.com)

The internal factors used in SWOT analysis are:

- Previous experience
- Knowledge
- Financial resources
- Labor resources
- Internal processes
- Reputation on market
- Timescales
- Competing projects

External factors of SWOT analysis:

- Technological development
- R&D improvement
- Market demand
- New markets
- Political factors
- Environmental factors
- Competitors
- Seasonal effects

1.4 Limitations and delimitations

During the theoretical research the project was limited with the literature sources of no older than 19 years, because rapid development of technologies, started in the beginning of the third millennium, was affecting on automation processes.

The focus during the research was held on Konepaja Astex Gear OY requirements for the conveyor line. As the project was taking place in Lappeenranta, Finland, the availability of required equipment was checked also in bordering countries, such as Sweden, Germany, Poland, Russia, Estonia, Lithuania. Unfortunately, the focus territory could not be worldwide which might make it impossible to find the best solution in technological and financial perspective.

In this thesis project work we were limited in:

- Time – the project was planned to be implemented in 6-7 months from the beginning (by the end of Spring 2019)
- Resources – the project was conducted by the author and periodical consultation with the supervisors.
- Project budget was limited on the level of €30 000, so we had to consider all possible options for the future automation project.
- Project facilities – case companies production sites were preferable in case if there would be no available options fitting the project requirements on the market

The case study included designing part and market research for the available options and further solution making.

2 Industrial automation

“Industrial automation is the creation of technology and its application in order to control and monitor the production and delivery of various goods and services. It performs tasks that were previously performed by humans.” – by techopedia.com, 2018.

“Industrial automation is the use of control systems, such as computers or robots, and information technologies for handling different processes and machineries in an industry to replace a human being.” – by Sure Controls Inc., 2016.

“Industrial automation means using computer software, machines or other technology to carry out a task which would otherwise be done by a human worker.” – by Alex Owen-Hill, 2017.

From all these definitions it is possible to state that automation – is a replacement of human labor with a CPU controlled machines and this makes it one of the best options in terms of repetitive and precise tasks on a production line. Automation involves intelligence, preciseness, non-standard approach and techniques to develop the production processes and to move it to a different level above.

Automation is one of the steps of humanity in long path Manual Labor > Mechanization > Automation > Robotization (Boboulos, 2014). The main difference between Mechanization and Automation processes is the control function. During the phases of automation, the control and observation functions and responsibilities are step by step transferred from a human to a CPU with a sensory system.

2.1 Levels of automation

There are 6 levels of industrial automation (Stenderson, 2005; Frohm, 2008; Lamb, 2013):

1. No automation.
2. Human assistance.
3. Partial automation.
4. Conditional automation.
5. High automation.
6. Full automation.

Level 1: No automation.

In this level of automation all task including execution, monitoring and fallback performance are provided by a human. That means having the highest possible rate of flexibility and variety of tasks to be able to produce. On this stage a production company doesn't need to make big investments in automation, keep low unemployment level but on the other side – production time is increased, more human errors lead to lack of accuracy and lower production volume.

Level 2: Human assistance.

On this level all the work, monitoring and fallback performance is still done by human, but the preliminary movement (rotation, moving, etc.) is done by an automated system. As an example, the first-generation manual machine-tools could be taken. They were able

to rotate the workpiece to provide more accuracy in stability in machining. This type of automated systems is not usually able to perform more than one driving mode.

Level 3: Partial automation.

On this stage monitoring and fallback performance are on human responsibility but the preliminary movement is done already by the system. Automated systems of this level are already including the basic CPU and sensors to gather and analyze the information about the driving environment in production site. The system is able to perform several driving modes.

Level 4: Conditional automation.

On this level the automated system is fully responsible for preliminary movements of workpieces and full monitoring of driving environments. That means more serious CPU device with more complicated sensory system that would be able to inform a human for better fallback performance. The system is still able to perform only few driving modes, as on level 3.

Level 5: High automation.

On this stage the automated driving system is responsible for all driving mode-specific application, controlling and monitoring of the driving environment and for fallback performance to secure the human operator. In this type of automated systems, the most intelligent and complicated CPU and sensory devices are applied for gathering the maximum information and its better analysis (flexible manufacturing units). The system is still not capable of execution of every driving modes.

Level 6: Full automation.

Full automation means that every single action is carried and controlled by a fully-automated driving system (flexible manufacturing systems). It is capable of movements, monitoring the driving environment and fallback performance on the same or even better level than a human. This type of automated systems is able to perform all driving modes that are possible with manual labor, but they are more precise, accurate and avoiding human errors.

2.2 Industrial automation today

In the end of 20th century all three layers of industrial automation: ICS – Industrial Control System, CADD - Computer Aided Design and Drafting, PCS – process control system;

were held separately and independently. They were created on the basis of different production and planning department's requirements, and were serving different sides of an enterprise, without any communication. The situation was getting more difficult due to the different standards used in devices, software and IT. Concerning all these facts it was hard enough for any enterprise to start the automation process because there were too many different options that could not be covered by any existing automation solution (In-Teh, 2009).

Nowadays the situation has totally changed. Today the main factor of success in automation process is constant communication and integration of every single branch of the enterprise, starting from the smallest production units and ending with the Board of directors. Due to the constant development of technological standards, hardware and software it became much easier to connect different levels of automation inside an enterprise without any additional costs. The second success factor would be the possibility to mate automation equipment of different manufacturers into a single complex system as they are based on the same code structure and are transparent for the automation engineers. The next important factor for better integration and improvement of connectivity between different enterprise departments is the Internet development and its deeper impact on all automation levels. This development seriously affects the ability of user to operate with the automation system such as decreasing connection and accessing times and facilitate gathering information (.

The latest trends in development in many industries is facing a problem of government regulation which are limiting the possibility to use human labor. These restrictions are lowering down the rate of productivity and the only way to avoid this problem from the beginning – implementation of the automation processes.

There is one more extremely important affecting factor on the automation process nowadays – people responsible for automation are themselves taking part in creation and development of the hardware and software. They understand that there are always possibilities to improve already existing products on markets to make them more flexible and user-friendly, more efficient and less expensive in a case where an enterprise has to combine several hardware/software to work together to accomplish the required task.

2.3 Advantages and disadvantages of industrial automation

After decades of years of mechanization, the world has entered in the phase of Automation in 1964, when IBM introduced the OS/360 operating system. The need of

implementing automated computer operations was obvious – there was an increasing need to perform complex, precise, repeating tasks for the further development of all industries. Since human mistakes play a vital role in any production of that time – that was a good call (Cameron, 2011; Gupta, 2016)

The new automated systems gave a lot of benefits to their users:

1. Cost reduction

The highest costs of any production facility are labor costs. The more a company is planning to produce – the more people they have to hire. Second important factor here is training of the employees which is also a costly event always. Implementing automated machines would also decrease the amount of needed working hours per single product.

2. Higher productivity

Unfortunately, a human productivity is limited due to the physical abilities of a person, so implementing automated machines instead is the next step for an enterprise in increasing production volumes. Implementation of automated systems in a very high-mixed production is significantly increasing productivity in comparison with the human's performance on the same site.

3. Quality increase

When all production processes are automated, and the production time of a single unit is decreased significantly – there is more time for quality checking before and after the production.

4. Accuracy and repeatability

As the main failure factor on production is also a human factor – replacing employees with precise, programmed automated machine would give more accurate results.

5. Increase in safety

Keeping employees out of dangerous site of a production plays a significant role in creating a safe working environment. Every automated machine nowadays has an exact operational space outside of which observation or monitoring is absolutely safe.

(Vista Industrial, 2013).

But on the other side introducing automated systems was followed by several disadvantages which were also quite significant:

1. Large initial costs

Any type of automated machines is slightly more expensive than manual ones. The higher automation level is implemented on a production site – the more expensive is the equipment and the more are maintaining costs. One of the most expensive parts of automation process is design of the system that would fulfill the needed requirements in the lowest costs.

2. Decrease in versatility

Machines are designed and programmed to complete single or multiple tasks and its variety of tasks is significantly lower than human can do.

3. Production change costs

In event of changing production processes and/or changes in products high cost would take place. In some cases, the already installed equipment would not be able to complete the needs of the production site and would have to be replaced which would lead to even more costs.

4. Increase in unemployment

Introduction of automated production systems is leading to decrease of demand in low-trained personnel and therefore – increasing the unemployment rate in the industry. On the other side – due to complexity of the systems the need of well-trained and highly-educated staff would also cause increase in labor costs.

(Murtaza, 2017).

2.4 Social impact of automation

During the last decades, industrial automation in terms of globalization became the one of the key success factors of business strategy. It helps business to develop faster, to get higher revenues, to become leaders in their operational fields. Unfortunately, social impact of industrial automation is not obvious for everybody outside the production industry and thus, this misunderstanding causes serious disagreement (Mayer, 2008).

For people employed in manufacturing industry automation gives several social benefits: the amount of physically hard work is decreased so there is a possibility to get more deep specialization or additional education, working conditions are improved which leads to lower amount of occupational injuries, etc.

On the other side, statistics shows that nowadays a significant number of employees are currently working in low-qualified positions (47% in USA, 35% in UK) and these people could be replaced by automated machines which would cause extremely high level of unemployment (Gray, 2017). In this case there appears a question: would those replaced people find something meaningful to do instead of their current position? Scientists and sociologists are trying to answer this topical question and find a solution that would calm down people employed in “risky” industries and secure their future.

One answer was found by Erik Brynjolfsson, professor of MIT and Paul Clarke, chief technology officer at Ocado Group plc. On their point of view the preparation of people for the future world with robots and Artificial Intelligence (AI) should start on educational level. Prof. Brynjolfsson and Mr. Clarke strongly believe that realizing the need of constant self-education during the life time should be in people’s mind since the early age (Martin, 2015).

Second possible decision could be the development of an “Concepts of user centered automation” formulated by Karl-Friedrich Kraiss and Nico Hamacher in 2001. They have stated the basic requirements for automation systems for better interrogation of individuals and machines for decreasing possible human-errors without eliminating the first ones.

3 Conveyors in industrial automation

Conveyor is the most world-wide known production equipment. Basically, the conveyor is a permanent transferring line for moving goods, workpieces or raw material in a desired place. There is no particular author of this device since the first belt conveyors were already in use in Europe in 17th century for irrigation and much earlier some prototypes of conveyor were used in Ancient China and Egypt in the middle of first Millennium.

The first official patent was given to Haiml Hoddar in 1905 and the first great success of using conveyors in production site was introduction of renewed “Highland Park” automotive industry facility by Ford Motor Company in 1913-1914.

Henry Ford has decided to upgrade the production site with the usage of conveying belts for every single car structure (engine assembly, body assembly, etc.). Each worker has

his only one functional task: it means that employees didn't need any special qualification and would perform as machine – quick and precise.

Implementation of conveying systems helped to decrease production time of a single Ford T-model from 12 to less than 2 hours, which influenced the labor costs and the price of a ready car has dropped from €16 500 to €7 200 (in terms of nowadays). Other optional cars available in US market those days were at least €30 000-39 000 and therefore T-model became the best-seller. After only year and a half, by April 1915, there were over 1 million cars produced and sold.

Utilization of automated conveying lines gave Henry Ford another possibility – to increase the employees minimum day salary to \$5, when the average in all industries were twice less. Automation processes lead to changing the working times of shifts – from 2 shifts of 9 hours to 3 shifts of 8 hours and allowed the factory to manufacture in 24/7 mode.

3.1 Conveyors, structure and classification

Nowadays conveyors are used in industrial sites all over the world. The main functions and structural elements stay the same as they were in the beginning of 20th century. With the help of constant scientific and technological progress conveying aggregates have become more functional. The machines are leading the production, synchronizing big amount of people working in the facility, saving time and efforts and are increasing productivity.

One more significant advantage of using an automated conveying system is a stable high level of occupational safety during the movement of loads.

Conveyor transportation is widely used in internal workshop movements which provides the ability to conduct constant technological processes for which other transportation techniques are not ensuring the required production rate.

As the conveyor is a machine to transfer the workpiece from A to B, its structure is quite simple. Every conveyor has a stationary frame, moving motor and working surface. Conveyors frame is the holding structure and provides stability. Moving motor is the drive of the conveyor, it can vary depending on the application and type of the conveyor but the most often used is an electric motor. Working surface also varies from the application and is responsible for moving the cargo.

Structure of a particular conveyor affects its classification. There are several divisions in conveyors classification (Murtaza, 2017):

- By method of transferring the moving load (using a motor or gravitational)
- By method of application of moving load (traction conveyors or conveyors without traction tools)
- By kinds of cargo (bulk cargo or piece cargo)
- By positioning (stationary, portable, self-movable)
- By loading capacity (is the conveyor able to accumulate loads)

3.2 Types of conveyors

Conveyors are used to transfer loads during the fixed paths. The main idea is to move a load from one place to another in a shortest time with lowest costs and minimal effort. Considering the wide number of possible loads and application it is possible to highlight the mainly used types of conveyors:

- Belt conveyors
- Bucket conveyors
- Chain conveyors
- Flight conveyor
- Overhead conveyors
- Roller conveyors and wheel conveyors
- Screw conveyors
- Slat conveyors
- Vertical conveyors

(College Industry Council on Material Handling Education, 2004; Moor, 2009)

Each of these types has its own structure and features, with advantages and disadvantages.

3.2.1 Belt Conveyors

This is one of the most widely used type of the conveyor. This type of conveyors is mostly used for packaging handling (airports, grocery stores), raw material handling (mining industries, agricultural industries) and for small part handling (various production lines). Belt conveyors structure consists of three main parts: frame with rollers (pulleys), motor

and conveying belt. Figure 2 shows the structure and the basic principle of a belt conveyor with a transfer gear unit.

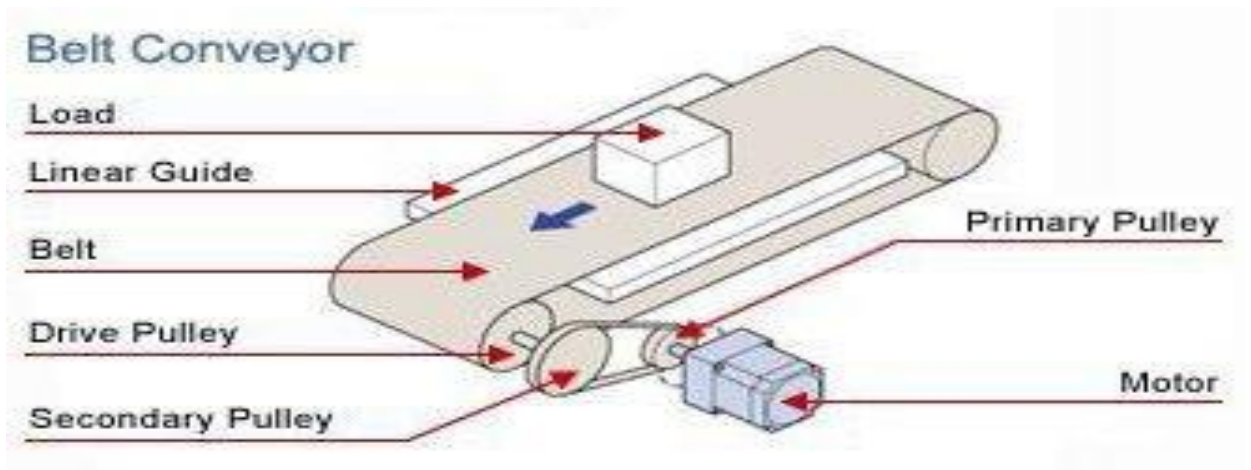

Figure 2. Belt conveyor structure (onvacations.co)

The main advantages and disadvantages of belt conveying systems are listed in the following table:

Advantages	Disadvantages
Simplicity of structure	Low universality
High reliability and capacity	Difficult to make 90 ° turns
Low initial costs	Limited transmission line
Low operational costs	Needs loading and unloading equipment
Possible for long distances	Loads are limited to structural strength
Possible for some vertical movements	

Table 1. Advantages and disadvantages of belt conveyors

As it is possible to see – belt conveyors are the basic automated structures for any kind of production sites. They are easy to use and maintain but requires some additional equipment for better integration in the production process. Also, there conveyors are slightly reliable, which is extremely important in for example mining industry.

3.2.2 Bucket conveyors

This type of conveying systems is very often used with bulk materials (ex. in mining industries, construction sites, food industry) and their vertical or inclined movements. Bucket conveyors offers the easiest solution for lifting the large amounts of material due to its structural features and therefore are required in high-volume production sites. These systems are highly recommended to use with dry, dusty materials.



Figure 3. Bucket conveying system (growerunited.com)

Figure 3 shows several examples of bucket attachment to the drive lines. The structure looks alike the normal belt conveyors – frame, motor, belt or chain with connected buckets. The need to introduce this type of conveying system was due to the limitation of gripping grade by the surfaces' friction forces and it might be impossible to apply normal belt conveyors for multiple load types.

The main advantages and disadvantages of bucket conveyors are listed in the table:

Advantages	Disadvantages
Suitable for bulk materials	Not suitable for wet loads and liquids
Automatically unloaded in the end of tray	Expensive equipment
High capacity	Heavy equipment
No need for extra equipment to change direction of movement	

Table 2. Advantages and disadvantages of bucket conveyors.

Usage of bucket conveyors in a high capacity production or for example in mining leads to increase of weight of equipment and therefore to bigger costs. Unfortunately, this way could be the only option in case that vertical or inclined movement of bulky materials is required.

3.2.3 Chain conveyors

This type of conveying system is often used in table transportation inside the facility. The material handling device is attached to moving chains to tow and drag the workpieces or packages in one direction. The main specifications that are in the designing process are application, configuration of the conveyor, capacity and power equipment. There is a possibility to transport bulk materials using special boxing or bins and to have several input/output points on the line. Several special modifications of chain conveyors are able to move material in any direction on surface.

The most often application of chain conveying systems is packing and logistics services. Due to the positioning of the material it is also possible to convey multiple workpieces on pallets and store them in special parts of the conveyor. It is also possible to meet these systems in airports and shopping malls as travolators, responsible for lifting people and their luggage.

The next figure shows one example of chain conveying system – a system with a single motor connected to two parallel chains on both sides of the frame. This particular conveyor is designed to move bulk loads in special opened containers in food industry.

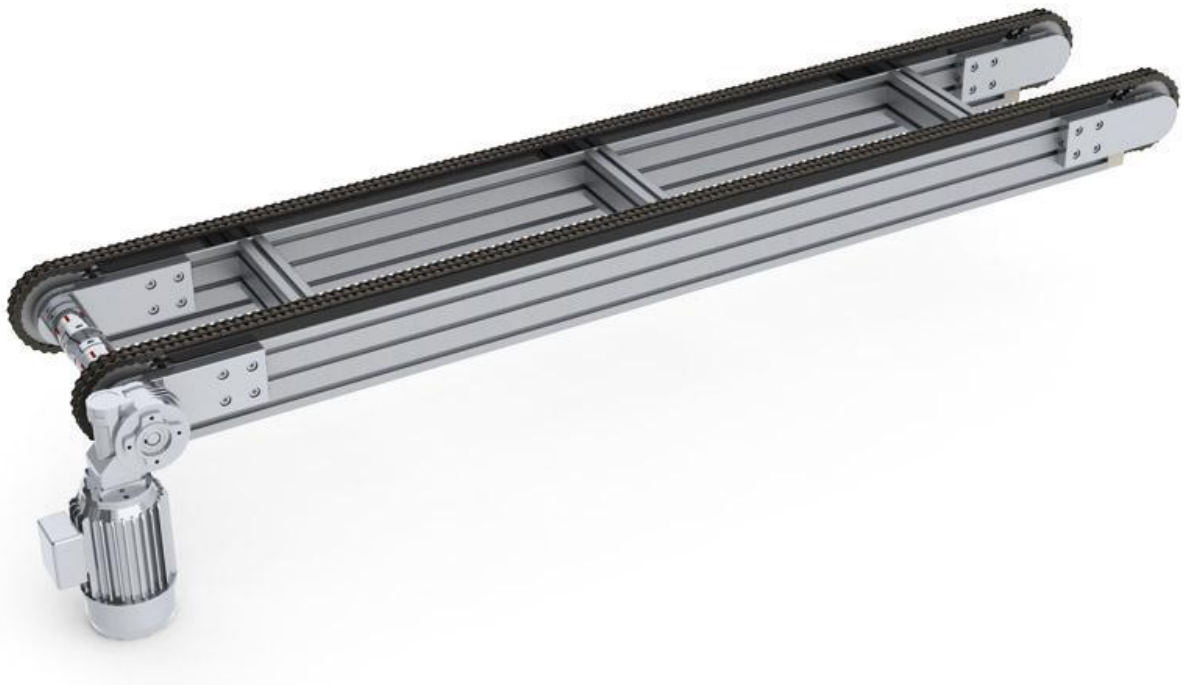

Figure 4. Chain conveyor (haberkorn.cz)

The main advantages of chain conveyors are:

1. Flexibility – chain provides more accuracy in case of several start/stop procedures due to ease of control of chain in comparison to belt.
2. Is possible to use in difficult condition (extremely low and high temperatures) – the chain is less sensitive than a belt.
3. The structure is simpler than in belt conveyor. One shaft is able to move several chains without significant increase of load.
4. Very reliable – moving parts are made of metal.

Chain conveyors, however, have also several important disadvantages that should be taken into the account:

1. Costly equipment – polymer or rubber belts are much cheaper than chains.
2. Chain requires accurate mounting and careful maintenance.
3. In case of stretching – the conveyor velocity would be slightly different from the planned that might cause mistakes.
4. Chain conveyors are not originally made for processing workpieces while transferring.

It is possible to state that usage of chain conveyors is justified in cases when there is a serious need in transporting heavy loads transporting, the moving would be done in difficult conditions or in case of package handling that requires preciseness and speed accuracy.

3.2.4 Flight conveyors

These conveying systems differs from other by the transferring mode. They consist of stationary body (gutter), and scrappers, connected to a moving chain or cable (Figure 5). Chain is travelling along the gutter and scrappers are moving bulk materials such as sand, coal or chemicals. These conveyors are mostly applied in mining industry, especially in coal mining.

Flight conveyors are better for transporting materials which are not subjected to shredding or materials which would not suffer from shredding.

Flight conveyors with chain are mostly used in food, chemical, pulp, woodworking and metallurgical industries for transferring bulk loads in sealed enclosure.

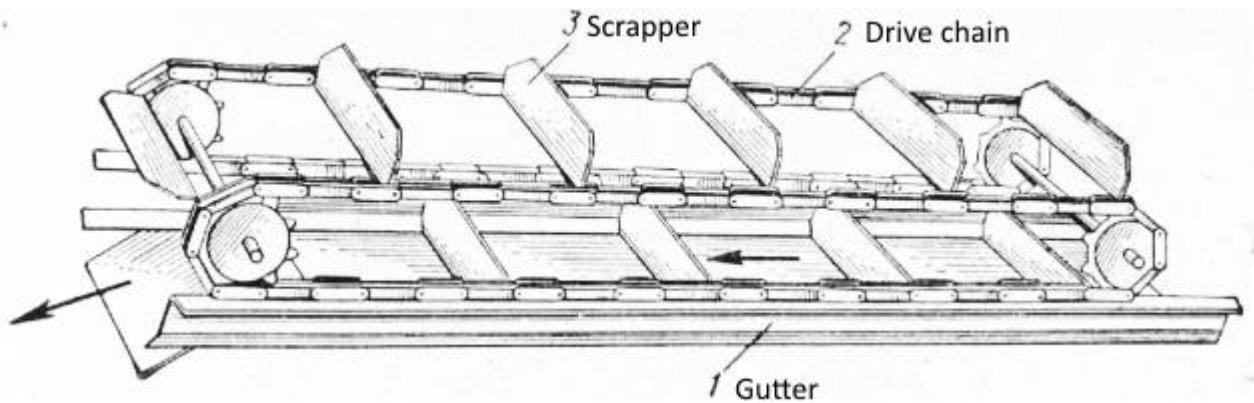

Figure 5. Flight conveyor (stroy-technics.ru)

The biggest advantage of flight conveyors is their flexibility because it is possible to transfer materials without overloads in direction changing points. Low installment costs would attract more enterprises to implement this transferring technique. High productivity of this conveyor type is guaranteed by high filling of gutter section. This is the only type of conveyor which could be loaded not only from the top but also from the sides which gives higher productivity rate. Usage of sealed enclosure allows to prevent spillages and pollution of both environment and transferred material.

Main disadvantage is obviously short lifecycle of scrapping equipment which is shortened by a permanent contact between scrapping tools and gutter and thus – to high maintenance costs. High friction values which are common in this conveying system lead to high power consumption. Saturation of transferred material with solid, rigid obstacles could also cause jamming and breakdowns.

3.2.5 Overhead conveyors

Overhead conveyors are used in cases where there are some limitations on using the floor space and there is a need for a very complex path of loads. They are mounted from ceilings or from supporting legs in order to keep the conveyor path above the ground. Chains or cables are normally used to drive the workpieces. This conveying system is mostly suitable for finishing, cleaning, painting and assembly lines. It is well known for its reliability and low required maintenance.

Figure 6 shows an example of an overhead conveyor: a chain is driven by a motor to move the workpieces (gas cylinders) along the desired path with both vertical and horizontal movements.

The most known application of overhead conveyors is automotive industry. Almost every single part of the car which needs painting and then assembling is delivered to the proceeding place by a conveyor of such type. Second common application is metal parts production by melting.



Figure 6. Overhead conveyor (siraga.com)

In the table above the main advantages and disadvantages of the overhead conveyers:

:

Advantages	Disadvantages
Extremely reliable	Expensive equipment
High universality	The building might be not strong enough
Can accumulate more loads	Requires high safety precautions
Require little maintenance	Require high trained personnel to install

Table 3. Advantages and disadvantages of overhead conveyor.

From the mentioned above it is possible to notice that the overhead conveying system is not the easiest in designing and construction. All the preliminary involvement stages should be held in accordance with the facilities nowadays and future needs as the overhead conveyers are difficult and expensive to upgrade. Otherwise the system is extremely reliable and the average period of using a single unit is the highest among the other types of conveyors.

3.2.6 Roller conveyors and wheel conveyors

These two types of conveyors have the same function – to provide constant and smooth movement of materials along the table with a usage of motor or just by external forces. It is possible to transfer only rigid objects of certain sizes otherwise they would be stuck.

Roller and wheel conveyors are mostly used in material handling application or in assembly lines as transfer devices between different processing stations.

The following figure shows the principle of roller and wheel conveyors: rollers and wheels are positioned between the frames and are either free to rotate or are driven by a motor.

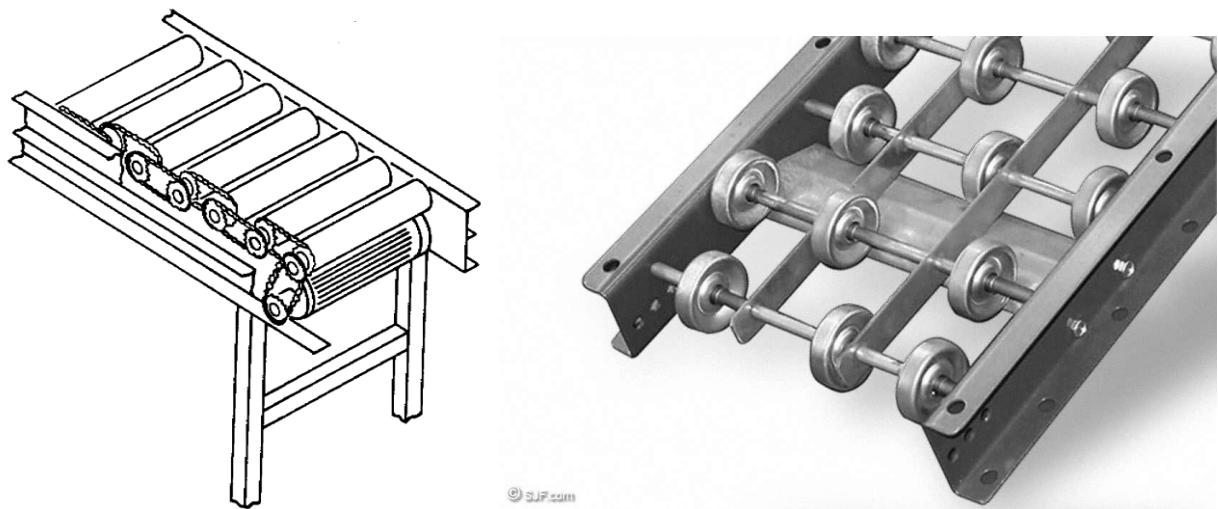

Figure 7. Roller conveyor (left) and wheel conveyor (right) (shmula.com)

It is also possible to accumulate material on these two types of conveyors and they are one of the best solutions for merging and sorting applications.

There are three prime differences between these conveying types: wheel conveyor is significantly cheaper, it is applied in light-duty applications and it is easy to make turns of any degree. On the other hand, roller is more expensive due to the structural issues, is capable of heavy-duty usage and turns could be applied in case on very big transportation unit size. The list of advantages in front of other conveying techniques is also quite simple: ability to accumulate, possible to operate without motor – requires noticeably less investment and requires less maintenance, both systems are enough flexible.

3.2.7 Screw conveyors

This type of conveying system differs from all other by the force application axis. Screw conveyor consists of a tube or U-shape gutter, with a rotating screw inside (Figure 7). The motor is normally connected to a screw by a reduction gearbox and a balancing coupling.

These conveyors are normally used for horizontal or inclined transportation of any types of bulk loads for short distances (up to 40 meters). In case a closed tube is used as a body vertical transportation is also possible with screw conveyors.

Screw conveying systems are the most common in processing industry. They are widely used in food handling, transportation of liquid concrete, chemicals and transfer of hot materials which could excrete harmful fumes or obstacles. Closed tube could be easily sealed to prevent harmful and dangerous situations.

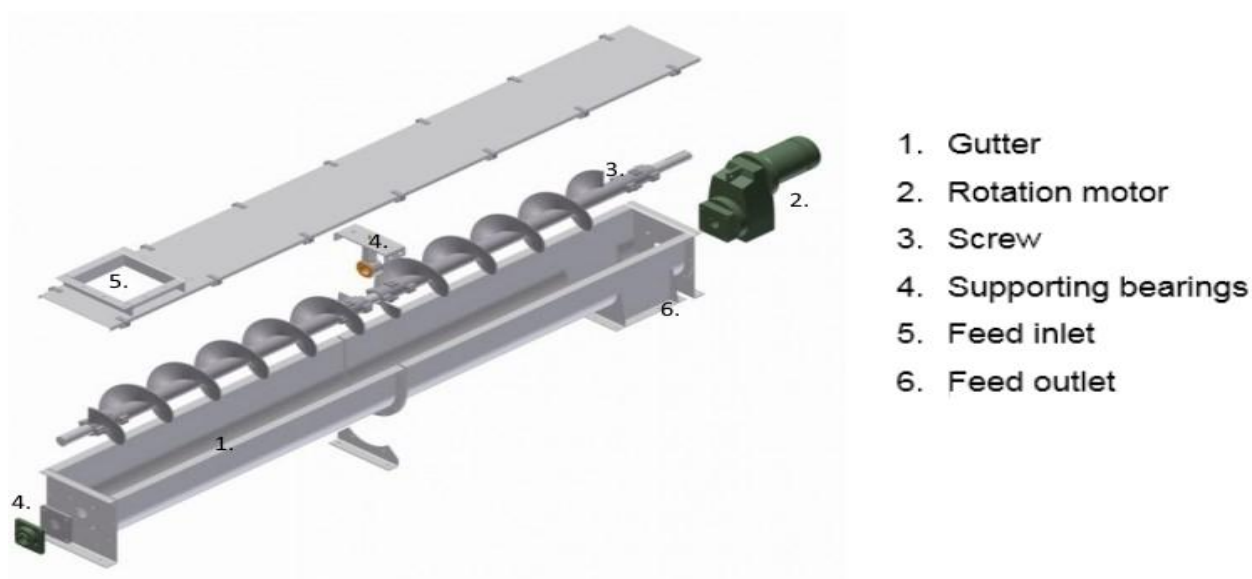

Figure 8. Screw conveyor scheme. (conveyoreng.com)

The main advantages of screw conveyors are: the variety of materials that the system is able to handle, possibility to have multiple inlet and outlet positions, absolutely prevent spillage in case of using a closed tube profiles, easily sealed to resist internal pressure which is extremely important while transferring hazardous materials.

The biggest disadvantage of screw conveyors is high power consumption in comparison with other transferring techniques. One more problem is a significant efficiency loss with inclined conveying lines. The maintenance costs could also higher in case of malfunction or failure due to the complexity of a structure and solid external body. Lifecycle of screw conveyor is shorter than others due to higher loads for less force application points.

3.2.8 Slat conveyors

Slat conveyors are used for transferring materials and goods between processing stations and are replacing normal belt conveyors in case of impossibility of their usage. It consists

of frame, motor, drive chain with connected slats forming a flexible floor (Figure 9). The load stays in the same position as in the belt conveyors. Mostly slat conveyors are used for heavy-duty applications or in case the possibility of belt damage by a load.

One of the prevalent usage of slat conveying systems is bottling processes. As orientation and placement of the load is totally controlled that is possible to proceed actions which requires high level of accuracy without removing loads from the conveyor.

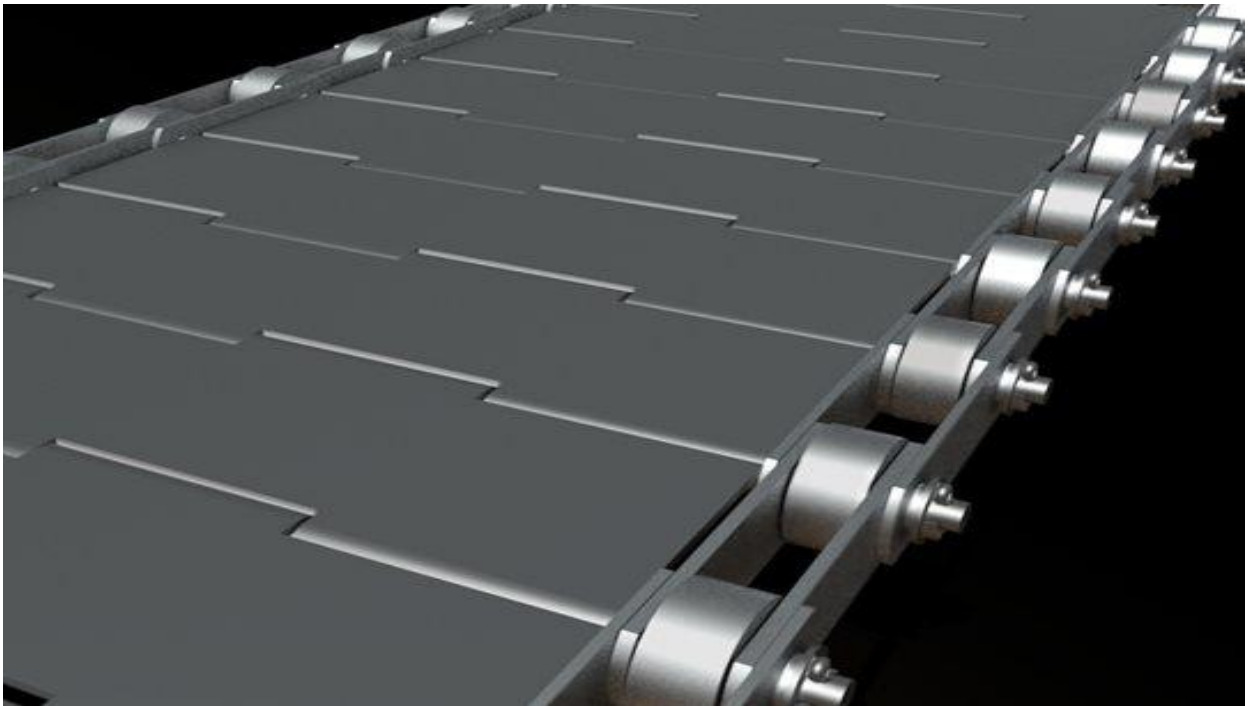

Figure 9. Slat conveyor (wirebelt.co.uk)

Slat conveyors have a great amount of benefits in comparison with other conveying methods:

- Very high reliability and accuracy
- High flexibility - can be used for horizontal, vertical and inclined paths
- Wider variety of transported loads than belt conveyors
- Perfect for sortation application
- Controlled position and orientation of loads
- Ease of service

The problems that could be faced while implementing slat conveying methods are the following:

- Initial costs could be significant in case of difficult moving path.

- well trained personnel are required for designing and installing the working system,
- lower transferring speed,
- high mass rate,
- high maintenance costs due to the big amount of hinge elements which requires lubrication.

3.2.9 Vertical conveyors

Vertical conveyor is a device to transfer materials between levels of conveying. It has a variety of application purposes and is widely used inside the production facilities in case of multi-level equipment. These machines could use either constant lifting mode or reciprocating mode. The usage of lifting conveyors is limited only with several factors: load capacity, load dimensions, lifting speed and electrical equipment requirements. Depending on application the construction of this conveyor type could vary but normally it consists of electric motor, drive belt/chain/cable going around guiding pulleys and rigidly connected planes or boxes. In case of lowering the loads there is always a possibility to apply the system working by gravity forces, simplifying the structure design.

These systems are quite often used in airports for luggage transportation and sortation, in chemical industries, in recycling plants.

Figure 10 shows an example of a lifting conveyor which is transferring packaging from down level to an upper one.

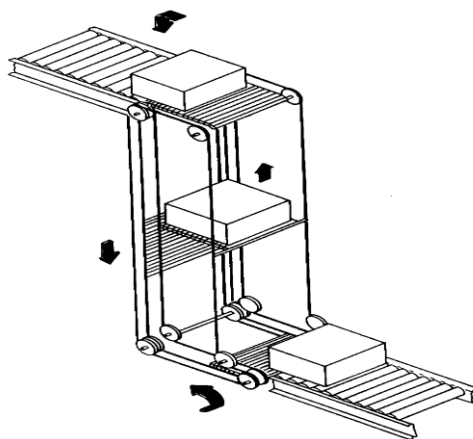

Figure 10. Vertical Conveyor (shmula.com)

The main advantage of vertical conveyor is its flexibility – plenty of options are available in the market and design is less costly than for other conveying systems capable of lifting movements. Second significant advantage is floor space saving - the conveyor is

operating only in vertical axis what allows to use it in limited areas. Low initial installation costs and low maintenance costs are also a serious competitive advantage in front of other lifting conveying technologies.

Vertical conveyor on the other side are strictly limited for size and weight of loads after the installment and modernization for different loads might require a purchase of totally new equipment.

3.3 Conveyors nowadays and future trends.

Concluding all mentioned above that is possible to state that conveyors have become an extremely important transportation technique of nowadays. It has a widest variety of application through any possible limitations and requirements in almost any industry - from the simplest belt and roller conveyors in grocery shops till the most difficult mixed structures in modern automotive factories or longest conveyors in mining industry.

Usage of the conveyors is seriously limited by several extremely important factors:

1. Type of the load
2. Load capacity
3. Distance of transportation
4. Working environment
5. Floor space

Implementation of conveying technologies on a facility requires a lot of preliminary work and well-trained and experienced personnel to design and install the equipment. The good way of modernization of a factory is to appeal a professional team of automation engineers for getting the solution which would nest meet the existing requirements and would be the most economic option. Conveyor system in production site would let the employer to organize a continuous production for increasing productivity and, thus, profitability, reduce labor costs, keep productional safety on high level.

High productivity rate, structural simplicity, fair initial costs, possibility to complete multiple technological tasks, improvement of working conditions – all these advantages of conveying system has made it one of the basic steps in industrial automation processes. As a main tool of transportation, it releases employees from slow, physically costly loading/unloading activities and increases production speed by keeping its rhythm.

The future trends of conveying are similar with others among machinery industry:

1. To increase long-term efficiency of conveying structure by implementing new materials
2. To cut the modernization expenses by introducing modular structured conveyors
3. To implement more efficient motors for reducing the energy costs
4. To create a universal conveyor for all indoor and outdoor applications;

The mentioned trends lead to the era of new conveying systems – universal mechanism for most of the applications, despite the working requirements.

4 Loads alignment and sensing in conveyors

Conveyor systems play a significant role in nowadays production mechanisms. They are capable of a controlled transfer of loads, workpieces packages etc. by a planned path with a desired speed. To provide these actions conveyors need to have a good positioning (alignment) and flow control systems (sensors).

4.1 Conveyor alignment systems

As every rigid load has Six Degrees of Freedom (Figure 11): three translational and three rotational, these movements need to be constrained for acquiring the best possible quality of transportation or of a ready product on production line. But usually there is a need to control a load only in one plane, so there are actually only three Degrees of Freedom taken onto consideration: two translational and one rotational (Cao; Lai; Cai; Jin, 2006).

There are several options how to position the load during transportation process:

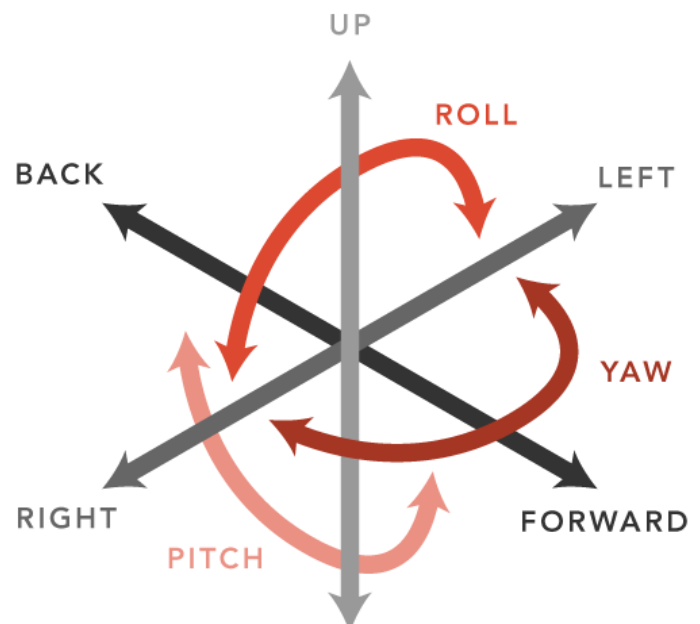

Figure 11. 6 Degrees of Freedom (kilograph.com)

4.1.1 Conveyor structure alignment

This type of positioning requires specific structure design of conveying system (Figure 12). The load is positioned by the inclined shape of the conveying belt or rollers to be in the middle or at the required angle. This alignment method is the easiest for implementation on the conveyor planning stage and allows maximum transferring speed and is mostly used for bulky materials or in applications where the accuracy of position could be neglected. This method is not usually approaching the strict requirements of positioning piece materials in production industries.



Figure 12. Inclined rollers for belt conveyor (amhltd.co.uk)

4.1.2 Mechanical alignment

Positioning using mechanical barriers is mostly applicable in roller or wheel conveyors. It is easy to implement due to the construction features (plenty of spare places between rollers or wheels). A series of barriers is installed (Figure 13) to provide smooth the main advantage of this method is the ability to make difficult paths for different applications all over the length of the conveyor. But to provide smooth moving of loads across the belt the conveyor should be long enough, otherwise a gorge could occur. This method is more precise than structure positioning but still might be not accurate enough, thus, is mostly suitable for transportation applications.

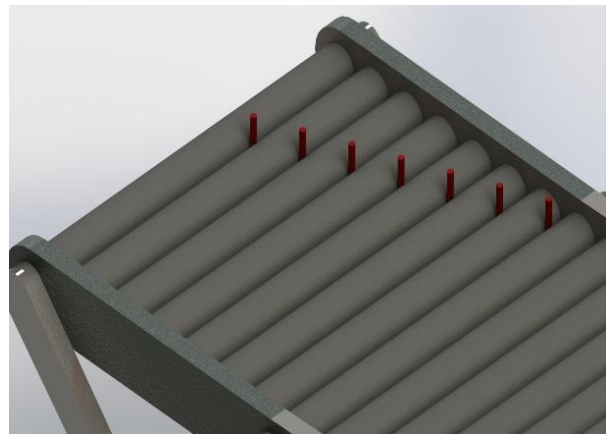

Figure 13. Mechanical barrier on roller conveyor

4.1.3 Alignment with a help of pushing device

This method is the most accurate among other positioning methods. The pushing device (Figure 14) is able to move loads with a required speed and for a required range in much faster time than mechanical or structural types of alignment.

The main benefit of the pushing device is a possibility to apply this structure for heavy loads (Ebel; Idler; Prede; Scholz, 2008).

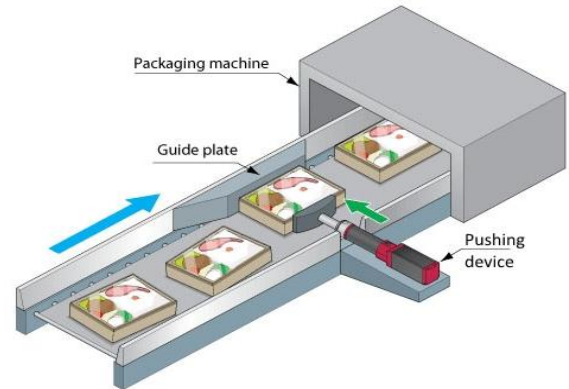

Figure 14. Pushing device in a packaging conveyor

There are several types of pushers that are normally used in conveyors:

- Electrical
- Pneumactical
- Servo pneumactical

These systems are more expensive and complicated than mechanical ones and they require more maintenance costs, but they are precise, reliable and have a long life-cycle.

4.2 Sensory Systems

Each automated system has a control unit between the movement actuator and movable component. In case of transfer conveyors, the main components of the control equipment are sensors and processing unit. The first component responsible for detecting the motions, presence, amounts, and all required physical data on the moving objects and transmitting the collected information to a processing unit which is able to represent it in a graphical form for further interpretation.

A sensor is a preliminary input device used to convert a single physical parameter into a digital signal for measurement. This component is capable of measuring the required parameter in terms of programmed scale for comparing and understanding the results and for control over the transfer flow.

All sensors used in transferring applications could be divided into two classes: analogue and digital sensors. Analogue sensors are able to produce a continuous output signal that will show the changes in current state of measured parameter in a form graphical form. A digital sensor is producing a discrete binary output signal in a form of logic "1" and "0" as "ON" and "OFF" respectively. The main disadvantage of analogue sensors in higher

response time and lower accuracy than a digital sensor. The bigger number of bits is used is a digital sensor – the higher is accuracy and lower the response time. Moreover, in many application analogue sensors requires additional power supply filtering device to produce a suitable output signal (RS Components Ltd, 2016).

There are several most commonly used types of sensors in transferring conveyors for detecting and controlling the piece material flow:

- Non-contact sensors:
 - Inductive
 - Capacitive
 - Photoelectric
 - Ultrasonic
- Contact sensors

4.2.1 Inductive sensors

This type of sensor consists of four main elements: inductive coils, oscillator, Schmitt trigger and output switching circle (amplifier). The inductive sensor principle of work is based on the symmetrical magnetic field created by oscillator which is directed from ferrite coils to the active surface. When a metal load is moved to a magnetic field area it is collapsing the field by reducing the amplitude of the oscillator and then causing a collapse. Schmitt triggers sends signal to sensor output. After a load is removed from the magnetic field the oscillator starts to work as before the collapse.

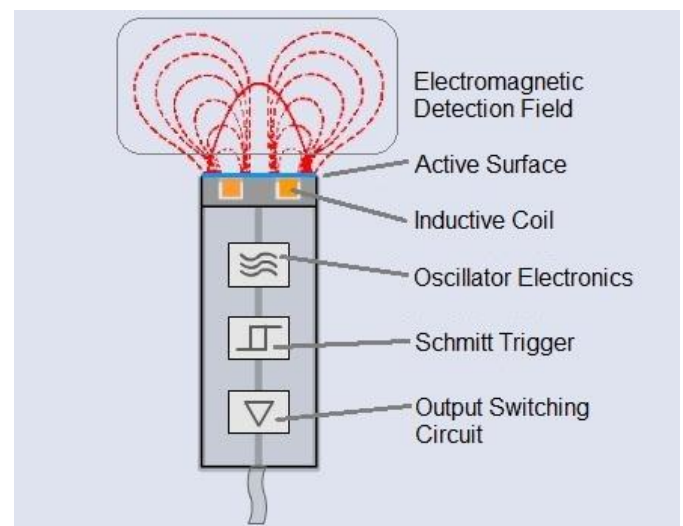

Figure 15. Inductive sensor structure

The benefits of using inductive sensors are: perfect in case of ferrous materials, long life as there is no contact with the material, high working environment resistance caused by structure features.

In case of implementing an inductive sensory system, it is important to remember that the operating area of devices are limited with the properties of magnetic field, application is

possible in case of only ferrous materials. The system also has narrow sensing range (up to 60 mm, depending on the environment).

4.2.2 Capacity sensors

These sensors are consisting of the following components: two capacitor (conduction) plates, oscillator, Schmitt trigger and amplifier.

The main principle is in detecting the capacity of a working environment: the two plates are operating to create an open capacitor and in case an object is

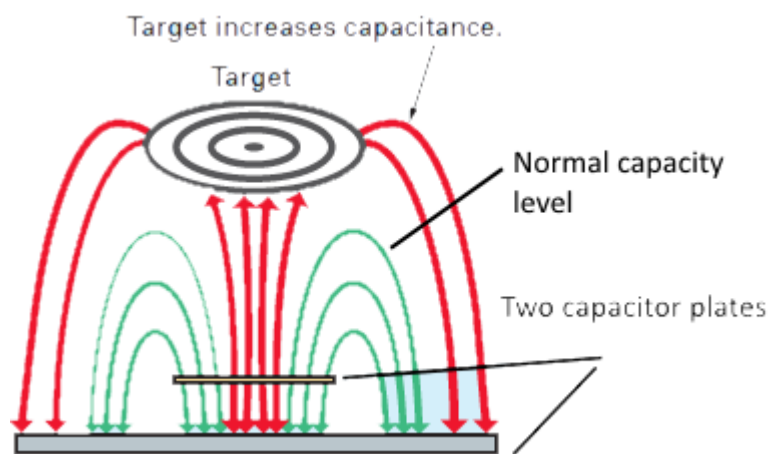

Figure 16. Capacity sensor principle

entering the sensing zone the overall capacity of two plates increases. Oscillator amplitude is changing and making a trigger to send an appropriate output signal. As opposite to the inductive sensors the oscillation is higher when the workpiece is in sensory area.

Capacitive proximity sensors are able to detect also non-ferritic and non-metallic targets of any state (liquid, bulk or piece form). Second advantage is the ability to work through the obstacles in the sensing area. Capacitive sensors are also limited to approximately 60 mm of sensing range and the flow of materials should be controlled very precisely as these sensors are able to detect non-target materials. The best application for these sensors would be liquid level detection or sight glass monitoring.

4.2.3 Photoelectric

Nowadays the most used sensors in conveying technologies are photoelectric sensors. This is a very flexible system capable of solving various detecting tasks. Photoelectric sensory system consists of three main components: emitter (light source), receiver (photodiode or phototransistor) and electrical equipment to amplify the signal. The emitter is transmitting a light (normal or infrared) beam to a receiver. In case the receiver is not getting the signal or getting a smaller part (in case of transparent loads on conveyor) the output signal is transmitted further to a CPU.

Photoelectric sensor's output signal could be varied depending on the application:

- Light-on, where the output is produced while the receiver is getting a signal
- Dark-on, where the output is produced while the receiver is not getting a signal

According to Kinney (2001), there are three main types of photoelectric sensory systems:

1. Through-beam

The most reliable and the most long-effective type of photoelectric sensors. The emitter and receiver are located separately, and the light beam is installed between them. When an object is entering the sensory area (Picture 17) it breaks the system and sends an output for a PLC.

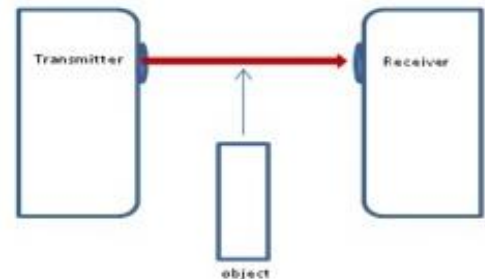

Figure 17. Through-beam sensor

This sensory scheme is the most reliable and provides the longest working distance one but on the same side is the most difficult to implement – initial and maintenance costs are high; installation and alignment processes could be difficult. This method is also requiring power cable installation on both sides of measuring for getting a result.

2. Retro-reflective

This sensory system is based on the same principle as a through-beam sensor but there is an additional element: a reflector is needed to transfer the signal back to located in the same place emitter and receiver. When an object is entering the sensor zone in breaks the light beam and provides an output signal for the CPU.

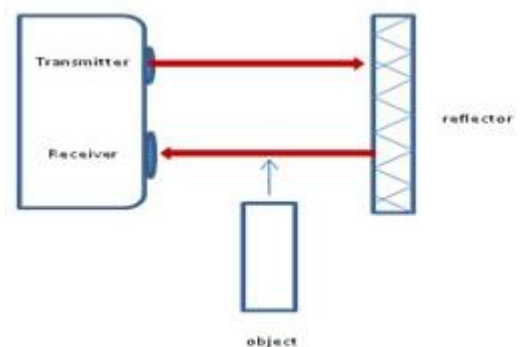

Figure 18. Retro-reflective sensor

Retro-reflective sensors are providing lower effective distances and are not able to maintain several objects that have reflective sides (ex. cans, glass). Despite this fact retro-reflective sensors are cheaper in costs, and easier to maintain and implement due to the need of mounting electrical equipment only on one side of the measuring.

3. Diffuse

In this sensory technology emitter and receiver are located in the same area as in retro-reflective sensors, but there is no additional reflector: this role is played by the transferred

object. The emitter sends a wide spread light beam (laser or infrared normally) and when the object is coming into a sensing zone a part of this beam is reflected back to the receiver (Engineers Garage, 2012).

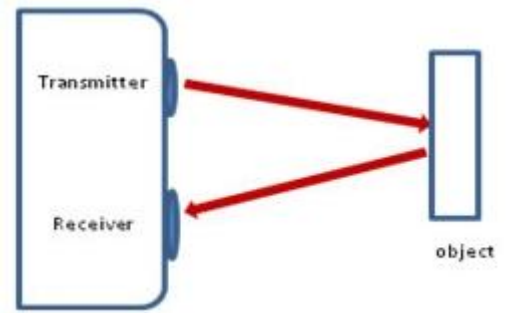

Figure 19. Diffuse sensor

Diffuse sensors are the cheapest ones among the other photoelectric sensors and are the easiest to implement but on the other side it is very sensitive to the color and surface properties of objects and thus require the most amount of time for planning and designing.

4.2.4 Ultrasonic

Ultrasonic proximity sensors are one of the most widely used in any industry. This type of sensors as capable of detecting any type of objects, including liquids flow, bulk material flow and pieces. The emitter is producing sonic pulses and then the receiver is waiting for a response from an estimated object. The system consists of emitting and receiving devices, PLC and sometimes reflector. The possible structure designs are the same as used in photoelectric sensing: through-beam, retro-refractive and diffuse.

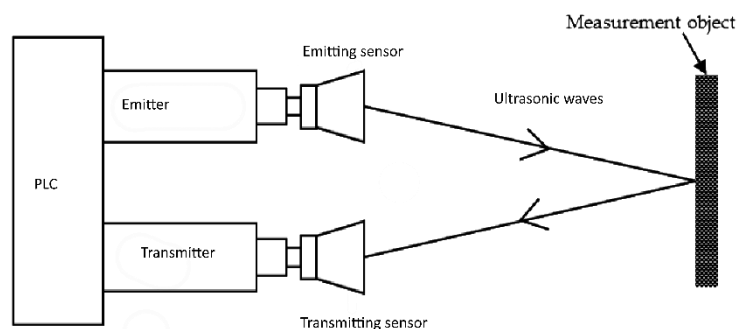

Figure 20. Ultrasonic sensor

The main advantage of ultrasonic sensors is their versatility and they are not affected by shape, color or material of objects (except several extreme textures). They have a huge operational distance and are flexible.

The main problems are also quite similar to the photoelectric sensors: initial and maintenance costs could be high; design and implementation could be difficult due to the working environment conditions – ultrasonic beam makes no difference of target and non-target materials.

The main problems are also quite similar to the photoelectric sensors: initial and maintenance costs could be high; design and implementation could be difficult due to the working environment conditions – ultrasonic beam makes no difference of target and non-target materials.

4.2.5 Contact sensors

Contact sensors or limit switches are the basic mechanical sensory devices in automation industry. They are electromechanically operated and require physical contact with the material on the conveyor. The basic examples are push-buttons or bumper-plates (Figure

15). These sensors are mostly used in sorting conveyors or in the end-point of the conveyor. The most serious disadvantage of contact sensors is the need of mechanical contact which could be impossible in case of small and multiple loads on the conveyor. On the other side, these sensory devices have very small initial and maintenance costs, are reliable and easy to operate.



Figure 21. Contact sensor (robotshop.com)

5 Automation project for Konepaja Astex Gear OY. Design process

The project was organized to have a possibility for transferring the workpieces to a machine room consisting of turning machine, milling machine and a robot-manipulator which was loading the machines with workpieces. Before implementation of the automation project machine room operator was manually loading the system with the workpieces installed on a special pallet with marked places. This process was taking a long time and slowing down the production rate. Since it was not possible to load two pallets in a similar way and then install it to exactly same positions the operator had to reprogram the gripping hand each time after the loading of input pallet.

Second factor affecting the productivity rate was the difference in workpieces dimensions. There were five main types of workpieces most commonly processed in the machine shop:

- Round shape, \varnothing 230mm, thickness 20mm
- Round shape, \varnothing 232mm, thickness 35mm
- Round shape, \varnothing 150mm, thickness 20mm
- Round shape, \varnothing 90mm, thickness 28mm
- Rectangular, 35x35x120mm

For gripping these dissimilar types of workpieces different tools were used: for round shaped 3-finger gripper, for rectangular – 4-finger gripper. Changing the equipment was also taking time and, thus, affecting the productivity and costs.

The design process was one of the main issues of the project. SolidWorks 2016 by Dassault Systems was used as a main designing software. SolidWorks is a CAD and CAE computer software suitable for designing, automation and industrial planning of any level. It is capable of constructing, technological preparations and control over processes and data flows during the production planning processes.

The design process was divided in several stages:

- Preliminary structure design,
- Holding tool design,
- Detailed conveyor design.

For this research, the first step was to decide the applicable types on conveyors that could be used in the machine shop. According to the theoretical impact it was possible to point out several conveying techniques from the list in Chapter 3 to get a deeper look and make a comparison analysis. They were: belt conveyors, chain conveyors, overhead conveyors, roller conveyors, slat conveyors and wheel conveyors. These types of conveying systems are used mostly for inside applications and are suitable for transferring rigid objects, what was required by project limitations.

One more important factor was the initial costs of a conveyor installment. As the project budget was limited on the level of EUR30 000, the importance of the factor could not be neglected. Next significant factor was maintenance costs. That meant not only the service costs but also the variable costs (electricity). Reliability is a crucial factor for every automated system due to the expensive equipment. A significant role was the flexibility rate of the conveyors as case company was planning to use it for transferring different sizes and shapes of loads. Last, but not least factor was an ease of usage of the new system. It was the first automation project for the case company in a long period and required several certain skills from employees.

For the comparison we used a scale “1” to “3” in which “1” is “poor”, “2” – “acceptable”, “3” – “well”. The result of market research could be seen in the following table:

Conveyor type	Rigid loads	Initial costs	Maintenance costs	Reliability	Flexibility	Ease of use	Overall points
Belt	+	3	3	3	2	3	14
Chain	+	1	2	3	3	2	11
Overhead	+	1	2	3	3	1	10
Roller	+	3	2	3	1	2	11
Slat	+	2	2	3	3	1	11
Wheel	+	3	2	2	3	1	11

Table 4. Comparison of conveyor types with case company's requirements.

The results of this stage were clear, and it was possible to notice that overall grade is mostly high, but the belt conveyor showed the highest point score. The decision was to use this type of the conveying system in the machine shop.

5.1 Preliminary structure design

At the first stage, it was necessary to come up with the belt conveyor design. As a possible solution, three main structures were projected: a roundabout conveyor (Appendix 1), spiral conveyor (Appendix 2) and a "snake"-type conveyor (Appendix 3).

Each of the mentioned types had its own advantages and disadvantages, so it was necessary to compare their main features for the production line. Main criteria were:

- space requirement (the main point was not to disturb other production facilities and keep as more space free as possible),
- ease of access (it was necessary to make a conveyor be able for adjustment and control all over the length),
- simple structure (the easier is the structure – the less there are potential problems),
- reasonable price (project budget was limited to EUR30 000).

For the comparison we used a scale "1" to "3" in which "1" is "poor", "2" – "acceptable", "3" – "well". The result could be seen in the following table:

Conveyor type	Criteria				Overall average grade
	Space requirement	Ease of access	Simple structure	Reasonable price	
Roundabout	2	2	3	3	2,5
Spiral	3	2	2	1	2
"Snake"-type	2	3	3	3	2,75

Table 5. Comparison of three different structures

From the table it is possible to see that all three options had overall grade of more or equal to “acceptable” but the “Snake”-type conveyor was of the highest rate.

5.2 Holding tool design

The next stage of designing process was a holder tool development. The main task during this design was to keep all various workpieces in one exact “zero-point”. Due to the fact that workpieces on the production line were of two shapes – round (diameters on range from 90mm to 232mm) and squared (35mm) the design should allow placing both types in one holder without additional manual or mechanical adjustment. Second important factor is the weight of the workpieces (up to 12-13 kg) which made the tool very demanding in hardness.

As a result of the designing process several options (Appendix 4) were planned depending on the clamping type. Each of this design is using pin-adjustment without any motors for budget saving and structure simplification.

Option 1: “Hand” holder.

This design type is typical for most modern conveying systems which need centering a workpiece on its surface. Tools of this type are using convergent guides forwarded to the upcoming workpiece. The “Hand” holder fitted all necessary requirements and the structure of the holder is simple – two sliding parts and a fixing pin. On the other side this structure required additional length of the conveyor for the moving parts which could cause extra investments.

Option 2: Alignment sleeve

The alignment sleeve tool was based on a railed structure. This unique design perfectly met established requests and was able to avoid the problem of over-using the conveyor

space for moving parts. Main structural feature and at the same time benefit was two-sides adjustment which gave more stability of the workpiece on the conveyor belt and made the tool more reliable.

Option 3: Moving shoulders.

This design was using “knee-joints” for positioning of the oncoming workpieces. Tool structure was simple and mostly meeting the requirements. Holder of this type was easily applicable for round shaped workpieces however there was a need of a second element for stopping the squared ones. This extra element could not only complicate the structure of conveyor table but also occupy additional space that would also cost more investments and lower efficiency.

5.3 Detailed conveyor design

The last stage in conveyor designing process was detailed representation of the entire structure which consisted of conveyor tables, holding tool and schematic image of a workpiece on it (Appendix 5).

The 3D modelling was done in two ways: a straight conveyor where the workpiece is not moving in vertical axes, and a conveyor with an inclined part for reducing the input level in the system. The second way was easier to control and to maintain in terms of programmable robot gripper but it was greatly more expensive for production and difficult for installation.

6 Market Research

During the analysis we had to consider only the conveyor systems that are applicable for our case study. As Konepaja Astex Gear Oy is a company with a wide range of products one of important factors would be production flexibility what means automated restructuring in case of a final product change (Konepaja Astex Gear Oy, 2018).

It was possible to state that case company was located between third and fourth level of automation. Still the sufficient part of work (all welding procedures) was done manually by humans but in the same time the wide use of CPU controlled machines and robot grippers was implemented. A successful automation project would lead Konepaja Astex Gear Oy to a level of conventional automation, described in Chapter 2.

6.1 SWOT analysis of automation project

SWOT analysis was the next stage of the automation project and was conducted in the same time as conveyor type selection. After taking into the consideration every affective and applicable factor in the case study it was possible to make the following analysis (Table 5).

The next stage of SWOT analysis was a detailed review of each column in order to highlight the most affecting factors for the decision making. To conduct this deeper research, it is necessary to answer for two more questions for each of the column and the answer would state the most considerable factor from the list.

	Helpful	Harmful
Internal factors	Strength	Weakness
	<ul style="list-style-type: none"> - Financial stability - No competing objects inside the company - Ability to gain knowledge 	<ul style="list-style-type: none"> - Lack of previous experience in conveyor implementation - Limited timescales - Limited budget - Lack of trained and experienced in automation personnel
External factors	Opportunities	Threats
	<ul style="list-style-type: none"> - Possibility to improve production line - Research results would affect company's performance - Ability to proceed orders faster and, thus, satisfy customer needs better - Possibility to get competitive advantages in front of others 	<ul style="list-style-type: none"> - Introducing of another transferring equipment would increase pollution effect of the production site. - The EU working legislation is struct for employers - Brexit (case company's revenues could be lower than expected)

Table 6. SWOT analysis of implementing a conveyor line

The questions are similar for the first two groups in internal factors row:

- Is this factor positively/negatively affecting client's satisfaction of company's revenues?
- Is the factor creating a competitive advantage/disadvantage?

If the factor was not affecting customer satisfaction, revenues or competitiveness it could be neglected in the decision-making process.

For the external possibilities the questions are the following:

- Is the possibility able to increase level of product satisfaction or increase company's revenues?
- Are there enough available resources/time to realize the possibility?

If it is difficult to answer the first question – the factor should be neglected. If there are not enough resources – leave the possibility to the next year or later.

For every threat the questions are the following:

- How the threat is able to reduce the level of product satisfaction or decrease company's revenues?
- What is the protentional threat period?

If it is difficult to answer the first question – the factor should be neglected. If the second question's answer is more than two years – factor could be neglected.

After conducting this deeper survey, we managed to highlight the most important factors for arriving with a decision of implementation of conveying system. The most important factors are listed in the following table:

	Strength	Weakness
Opportunities	Financial stability	Lack of previous experience
Threats	Ability to proceed orders faster and, thus, satisfy customer needs better	EU legislation and effects of brexit

Table 7. Second stage of SWOT-analysis

The results of the second stage of the analysis were clear and showed that the perspective of involvement a conveyor system in a machine shop in Konepaja Astex Gear OY had stronger positive factors than negative ones. SWOT analysis has stated the main competitive advantages and threats of the automation project and the results would be used in decision making processes.

6.2 Potential customers. Market research

For conducting the market research it was necessary to study the market offers in automating industry and especially in conveying technologies. For better understanding the situation it was also required to check the available prices levels of different conveyor systems.

From the perspective of a customer, market research is a process of acquiring information of the state of market offer for customer satisfaction. With the correct limitation and requirements installed it is possible to find the most applicable solution existing on the market (Becker, 2018).

The next step of research was to determine studying area. After a short consultation it was decided to be conducted in seven countries including Finland. Company selection criteria were determined during discussion with the supervisor from Konepaja Astex Gear Oy Esa Astikainen. The criteria were:

- Close areas with an ease of communication and transportation ways
- Delivery times were also taken into the account
- Company's image and financial reports
- English-speaking personnel was highly required

The research involved forty-three companies (Appendix 6) operating in the field of automated conveyors design and production. The countries which were studied were listed below (with the amount of companies chosen):

- Estonia (three)
- Finland (thirteen)
- Germany (two)
- Lithuania (one)
- Poland (seven)

- Russia (eight)
- Sweden (nine)

After completing of this stage, the design part of the project was finished and the creation a request list became possible. All requirements were organized, listed and assembled to compose the specification for the conveying system (Appendix 7). This specification was sent to the companies chosen during the research process in the middle of October 2018.

During this stage companies were sent a request for the possible solution of case company case. Unfortunately, barely all emails were unanswered and even unread. Several companies have replied with a deny during a week - in both cases their production schedule was filled for most part of year 2019.

One possible reason could have been the usage of common company's email address and using as a sender email-service provider "gmail.com" domain. From the previous practice, it was possible to state that a significant amount of emails was not reaching destination and getting into trash-bin or was blocked by a firewall. For more detailed and guaranteed result, it was needed to change a strategy.

The more precise company research was organized and instead of contacting companies common address it was necessary to identify persons responsible for automation projects: sales engineers, production engineers, sales department managers. Normally, there was a possibility to get these email addresses and even working phone numbers either on company's websites or in specific services as "finder.fi".

For the second stage it was necessary to narrow the list of the companies and include only those which already informed about their interest in this project and organizations with the highest potential for successful project completement. A series of factors was highlighted for the comparison of potential equipment providers:

- Foundation year – companies with a prosperous history were preferable as experience is an important factor for a client
- Financial stability – most companies are keeping their financial records opened for public examination
- Year turnover and number of personnel – these two factors are also referring to a potential of an enterprise

- Logistics – transportation ease and costs have a great effect on the implementation process on any equipment (was rated as a range “1” to “5”, where “1” is time-taking, difficult and expensive, and “5” is fast and economical)
- Post-sale service – due to an inexperience of case company in working with automated conveying system the after-sale service requirement was included in the list (was rated as a range “1” to “5”, where “1” is not provided or fully paid by an equipment operator, and “5” is included in the price during the warranty period).
- Warranty – the period during which the possible failures handling is guaranteed by an equipment provider
- Additional information – intentions of an equipment provider to share complementary information on the production such as compatible equipment and providers, previous experiences for better decision making, etc.

As the result it was possible to state fourteen companies from different countries of initial list and their results could be seen in the following table:

	Foundation year	Financial stability	Year turnover (MM EUR)	Personnel	Logistics (range 1...5)	Post-sale service (range 1...5)	Varanty (years)	Supporting information
OEM Automatic Oy	1980	Increase	43,5	98	3	4	2	yes
Algol Technics Oy	1977	Stable	25,5	130	3	5	2	yes
SSI Schäfer Finland	2006	Stable	22	27	4	3	2	yes
Conveyers LTD	1970	Increase	16,8	37	3	4	2	yes
Fredriksons	2003	Stable	12	3	1	2	1	no
SICK OY	1991	Increase	7,6	31	4	4	2	yes
ALTRATEC	1981	Stable	7	11	2	1	1	no
APL Production AS	1992	Stable	6	3	3	4	2	no
Norcar-BSB Oy Ab	1979	Decrease	4,7	32	2	3	1	no
Global Engineering	2006	Decrease	4	16	5	4	1	no
Flexlink	2009	Increase	4	9	3	4	2	yes
ConveyorSystems	1994	Increase	1,8	6	3	3	1	no
MAT Service Oy	2000	Decrease	0,7	5	3	2	1	yes

Table 8. Second stage of customer selection.

Two months later, in December 2018, after multiple conversations and clarification of details with companies listed in Table 8, three commercial proposals (marked with green color in table 8) were obtained and provided for comparison and final decision making.

7 Results

In the beginning of the research there were several questions stated and, in the end, it was possible to answer on all of them.

- What are the features of different levels of automation?

The main feature of each automation level is a degree on which a CPU control unit is involved in three main processes of production: execution, monitoring and fallback performance.

- What are the main conveyor types used nowadays?

The main conveyor types which are in use in modern transportation application are: belt conveyors, bucket conveyors, chain conveyors, flight conveyor, overhead conveyors, roller conveyors, screw conveyors, slat conveyors, vertical conveyors and wheel conveyors. They all have various features, advantages, disadvantages and are applicable in different industries to fulfill varied requirements.

- What are the affecting factors on the production site at Konepaja Astex Gear Oy?

During the research it was possible to determine six most important factors affecting the choice of conveying system by case company: ability of processing rigid loads, low initial and maintenance costs, high reliability rate, high flexibility due to the variety of manufactured workpieces, ease of usage and implementation processes due to the lack of highly trained personnel.

- What are the possible designs of the structure to meet the requirements?

After analyzing all affecting factors, it was possible to conduct the priority conveyor type to be checked on the market. Belt conveyor was decided to meet mostly the requirements and, thus, was sent to a designing process.

A combination of straight conveyors was chosen as a main structure and the second phase of design process was a holding/stopping device development. After several video simulations and literature review several possibilities were determined, designed and compared. Production of the holding equipment would be accomplished by case company facilities as the cheapest possible solution.

- Is there a fitting solution on the market?

In the beginning of the research there were several concerns that too strict requirements and limited budget would make the research unsuccessful but after better contemplation of a research subject it became possible. Several months after the first and second research stages were accomplished – the full list of specification with a desired structure was created. It was sent to a considerable amount of companies which were chosen in the studying area of Finland and six others close in countries. After multiple clarification of details, three commercial proposals were obtained and provided to Konepaja Astex Gear Oy for comparison and final decision making. The results of the research gave knowledge for further automation projects for the case company and would help in their realization.

As the thesis project had several limitations: time, size of research group, technological and geographical restrictions, it should be assumed as a limited research. Technological and geographical and time restrictions played the biggest role on the market research process and limited potential countries of equipment providers. One of the easiest options was to conduct a market research in China and Taiwan areas but according to at least three times longer transportation period, absence of post-production service and high transportation and import costs, this would lead to a fail in main requirements.

A serious change of preliminary idea took place after initial literature research and first consultations with supervisors: the researcher planned to introduce a single roller conveyor solution for the whole automated line but faced multiple difficulties in designing process stage. These difficulties were aggravated when the exact information on possible workpieces dimensions was received from a case company. This also led to a change in a positioning device design process and, thus, created several possible options instead of researcher's first intentions.

The main experience for the researcher was the opportunity to expand and widen knowledge on automation processes, to conduct a market research in the field of studies, to get some practice in communication with potential providers of equipment and the ability to adapt preliminary plans according to the appearing information and conditions.

This project gave an opportunity to conduct several more researches for example for the best possible controlling device units and programming methods for full implementation of automated conveying system onto the production site of Konepaja Astex Gear OY.

Figures

Figure 1. SWOT analysis,	p.7
Figure 2. Belt conveyor structure,	p.17
Figure 3. Bucket conveying system,	p.18
Figure 4. Chain conveyor,	p.19
Figure 5. Flight conveyor,	p.21
Figure 6. Overhead conveyor,	p.22
Figure 7. Roller conveyor and wheel conveyor,	p.23
Figure 8. Screw conveyor scheme,	p.24
Figure 9. Slat conveyor,	p.25
Figure 10. Vertical Conveyor,	p.26
Figure 11. 6 Degrees of Freedom,	p.28
Figure 12. Inclined rollers for belt conveyor,	p.29
Figure 13. Mechanical barrier on roller conveyor,	p.29
Figure 14. Pushing device in a packaging conveyor,	p.30
Figure 15. Inductive sensor structure,	p.31
Figure 16. Capacity sensor principle,	p.32
Figure 17. Through-beam sensor,	p.33
Figure 18. Retro-reflective sensor,	p.33
Figure 19. Diffuse sensor,	p.34
Figure 20. Ultrasonic sensor,	p.34
Figure 21. Contact sensor (robotshop.com),	p.35

Tables

Table 1. Advantages and disadvantages of belt conveyors,	p.17
Table 2. Advantages and disadvantages of bucket conveyors,	p.18
Table 3. Advantages and disadvantages of overhead conveyor,	p.22
Table 4. Comparison of conveyor types with case company's requirements,	p.37
Table 5. Comparison of three different structures,	p.38
Table 6. SWOT analysis of implementing a conveyor line,	p.40
Table 7. Second stage of SWOT-analysis,	p.41
Table 8. Second stage of customer selection	p.44

References

- Becker, B., 2018. The Definition of Market Research in 100 Words or Less. <https://blog.hubspot.com/marketing/market-research-definition>. Assessed on 15.10.2018
- Boboulos M.A., 2014. Automation and robotics: 1st edition. eBook by Bookboon.com. ISBN 978-87-7681-696-4
- Cameron P. 2011. Advantages of Automation. <https://www.helpsystems.com/resources/guides/automated-operations-5-benefits-your-organization>. Assessed on 20.10.2018
- Cao, J., Lai, X., Cai, W., Jin, S., 2006. Variation analysis for rigid workpiece location consider quadratic effects using the method of moments. Journal of Manufacturing Science and Engineering 01/2008. Warren, Michigan
- College Industry Council on Material Handling Education, 2004. I-A. Conveyors <https://people.engr.ncsu.edu/kay/mhetax/TransEq/Conv/index.htm>. Assessed on 30.11.2018
- Ebel, F., Idler, S., Prede, G., Scholz, D., 2008. FESTO Fundamentals of automation technology. Technical book, pp.15-18. Denkendorf, Germany
- Electronics Tutorials, 2014. Position Sensors and Linear Position Sensors, Basic Electronics Tutorials and Revision https://www.electronics-tutorials.ws/io/io_2.html assessed on 10.01.2019
- Electronics Tutorials, 2014. Sensors and Transducers and Introduction, Basic Electronics Tutorials and Revision. https://www.electronics-tutorials.ws/io/io_1.html. Assessed on 11.01.2019
- Engineers Garage, 2012. Sensors: Different Types of Sensors. <https://www.engineersgarage.com/articles/sensors>. Assessed on 11.01.2019
- Frohm, J., 2008. Levels of automation in production systems. Thesis for the degree of Doctor of Philosophy. pp. 63-69. Charmles University of Technology. Department of Product and Production Development. Sweden.
- Gray, R., 2017. How automation will affect you – the expert’s view. <http://www.bbc.com/future/story/20170522-how-automation-would-affect-you-the-experts-view>. Assessed on 22.10.2018
- Gupta, A.K., Arora S.K., Westcorr J.R., 2016. Industrial Automation and Robotics: An Introduction: Har/Cdr edition. Mercury Learning & Information;
- In-Teh, 2009. AUTOMATION & CONTROL - Theory and Practice. Ed. Rodić, A.D. India
- Kinney, A.T, 2001. Proximity Sensors Compared: Inductive, Capacitive, Photoelectric, and Ultrasonic. Application engineer, Baumer Electric.

Konepaja Astex Gear Oy, 2018. Historia. <http://www.astex.fi/index.php?p=3>. Assessed on 10.10.2018

Kotler, P. & Keller, K. L. 2006. Marketing Management. Twelfth edition. Upper Saddle River, New Jersey, USA: Pearson Education, Inc.

Lamb, F. 2013. Industrial Automation: Hands on: 1st edition. McGraw-Hill Education

Martin, J.P., 2015. The Value of Automation: The Best Investment an Industrial Company Can Make. International Society of Automation

Mayer, F., 2008. Social impact of automation trends and issues: human centered systems engineering perspective. The International Federation of Automatic Control. IFAC Proceedings Volumes, pp 5251-5256. Seoul, Korea.

Moor, B., 2009. Belt vs Chain-slat bagasse conveyors for boiler feeding. Consultant to Bosch Projects, pp. 285-289, Durban

Murtaza, A., 2017. Conveyors and types. Slideshare.net
<https://www.slideshare.net/aly96/conveyors-and-types>. Assessed on 1.12.2018

Owen-Hill, A. 2017. What's the Difference Between Automation and Robotics?
<https://blog.robotiq.com/whats-the-difference-between-automation-and-robotics>. Assessed on 15.10.2018

RS Components Ltd, 2016. Photoelectric Sensors - The 3 basic Modes of Operation, brochure, UK. <https://uk.rs-online.com/generalDisplay.html?id=solutions/photoelectric-sensors>. Assessed on 11.01.2019

Stenerson, J. 2005. Industrial Automation and Process Control: 3rd edition. Prentice Hall

Surecontrols.com 2016. What is industrial automation.
<https://www.surecontrols.com/what-is-industrial-automation>. Assessed on 15.10.2018

Techopedia.com 2014. IT-automation.
<https://www.techopedia.com/definition/32099/automation>. Assessed on 15.10.2018

Vista Industrial, 2013. Advantages and Disadvantages of Automation in Manufacturing.
<http://www.vista-industrial.com/blog/advantages-and-disadvantages-of-automation-in-manufacturing/>. Assessed on 20.10.2018

Waugh, A. 2010. AutomationDirect, Automation Library articles.
<https://library.automationdirect.com/what-is-a-limit-switch/>. Assessed on 10.01.2019

Appendices

Appendix 1 A roundabout conveyor design

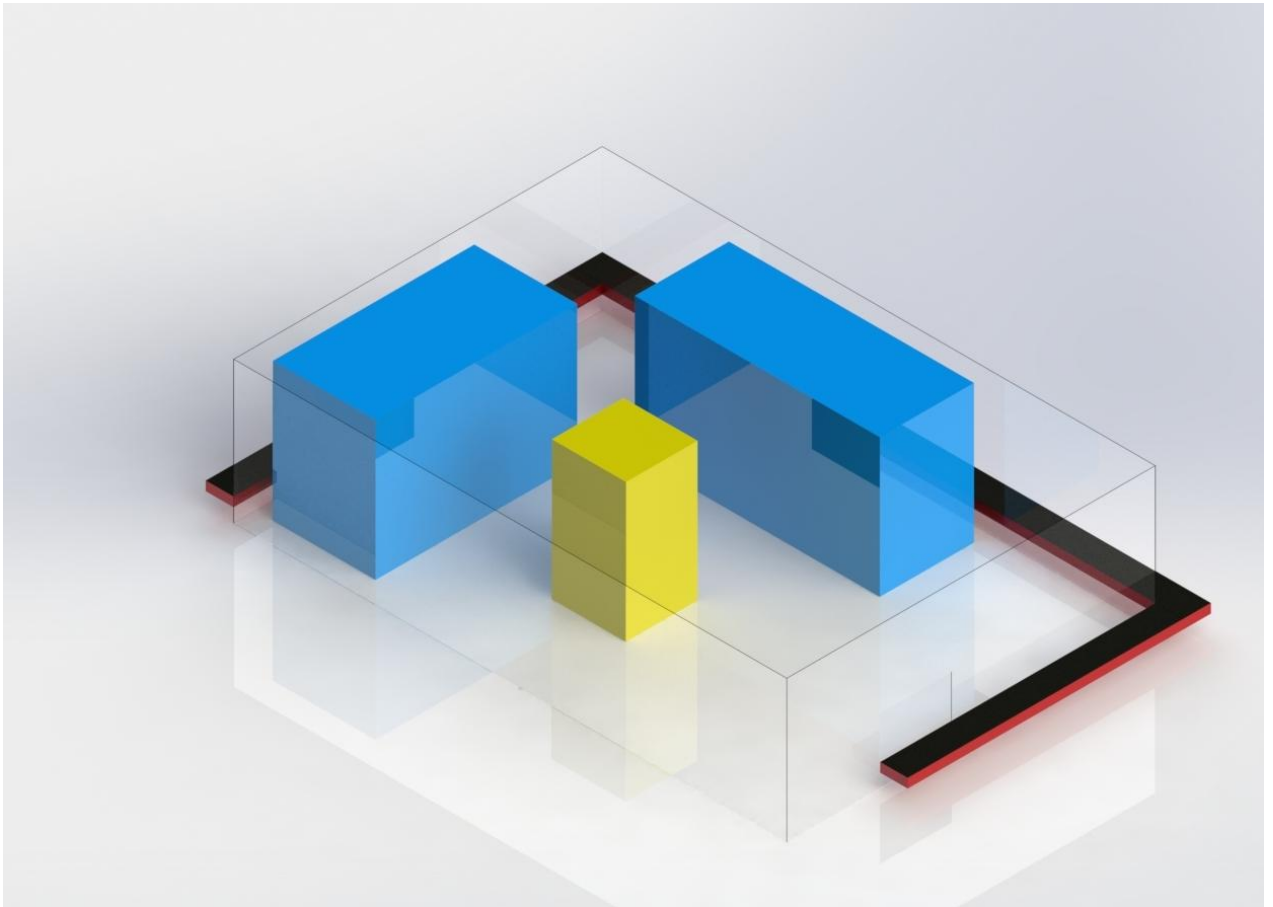

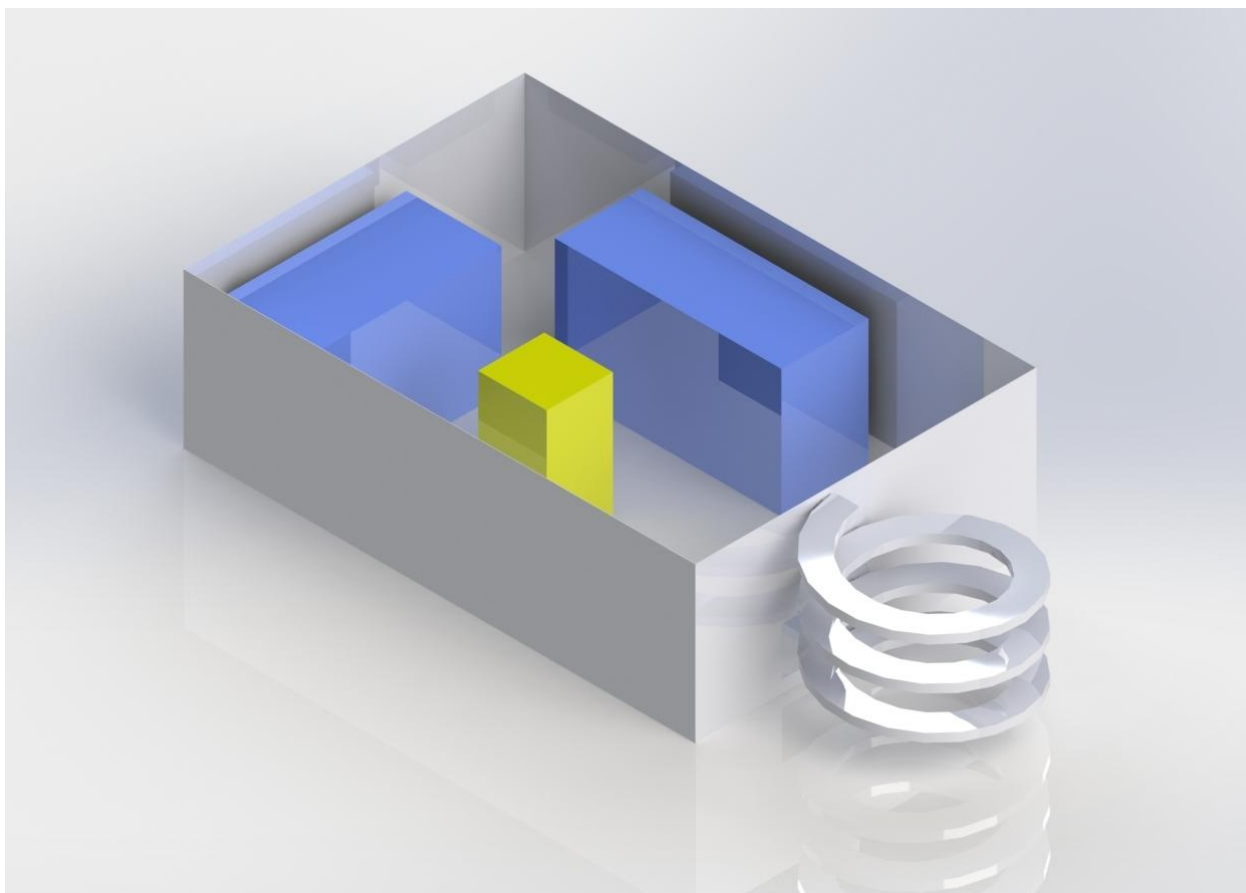

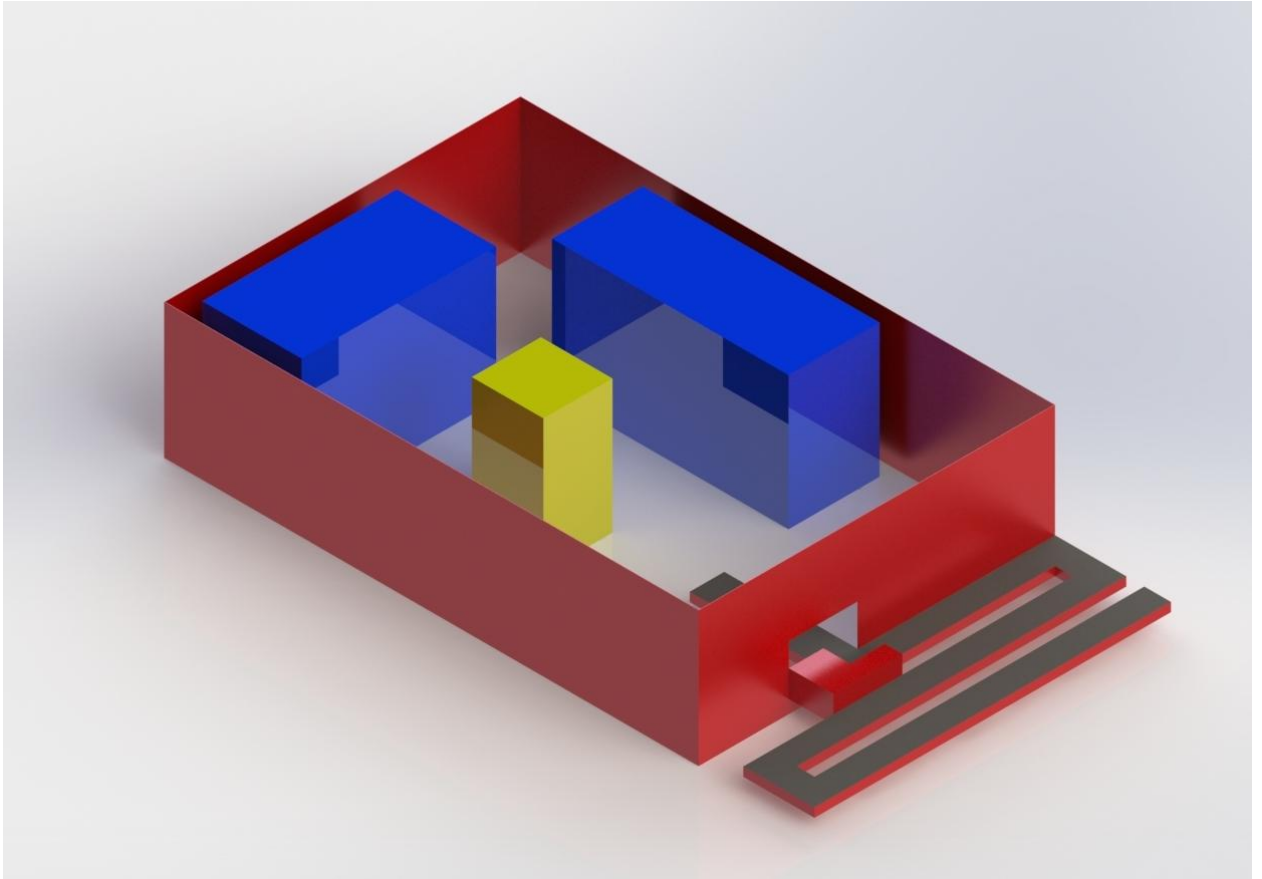



"Hand"-holder

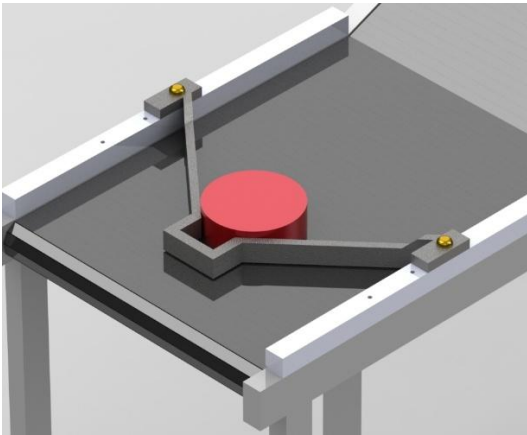

Alignment sleeve



Moving shoulders

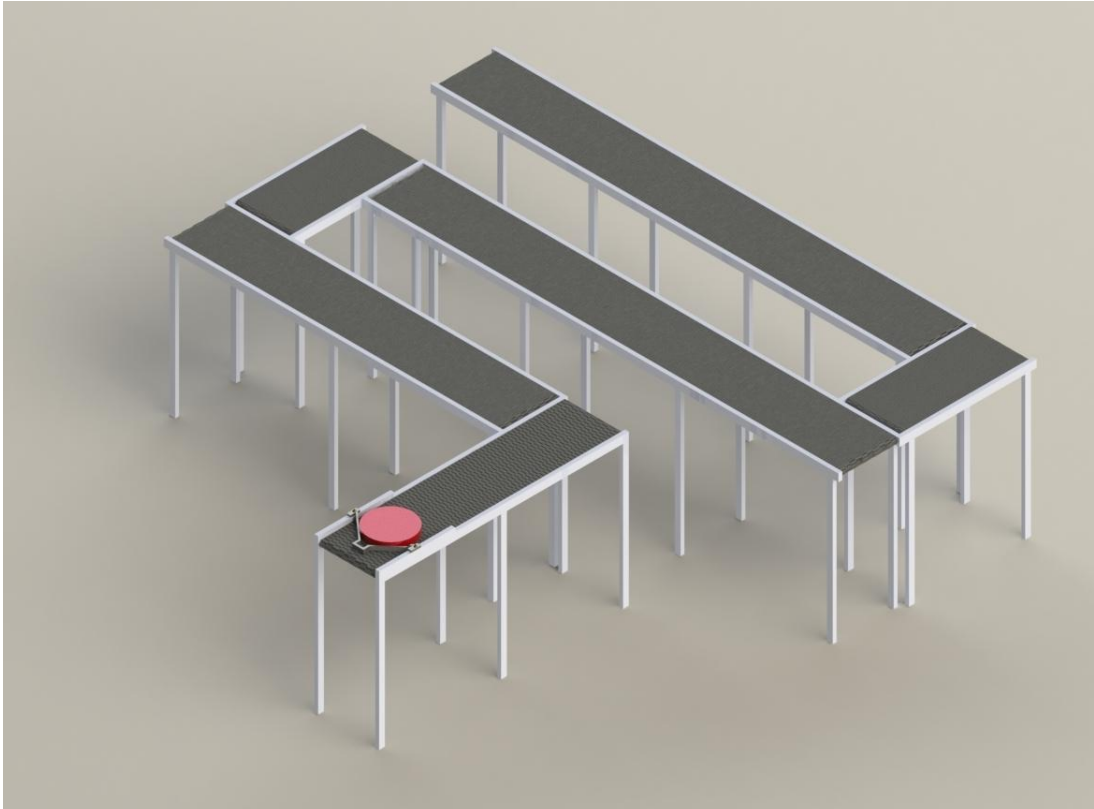

Straight conveyor option

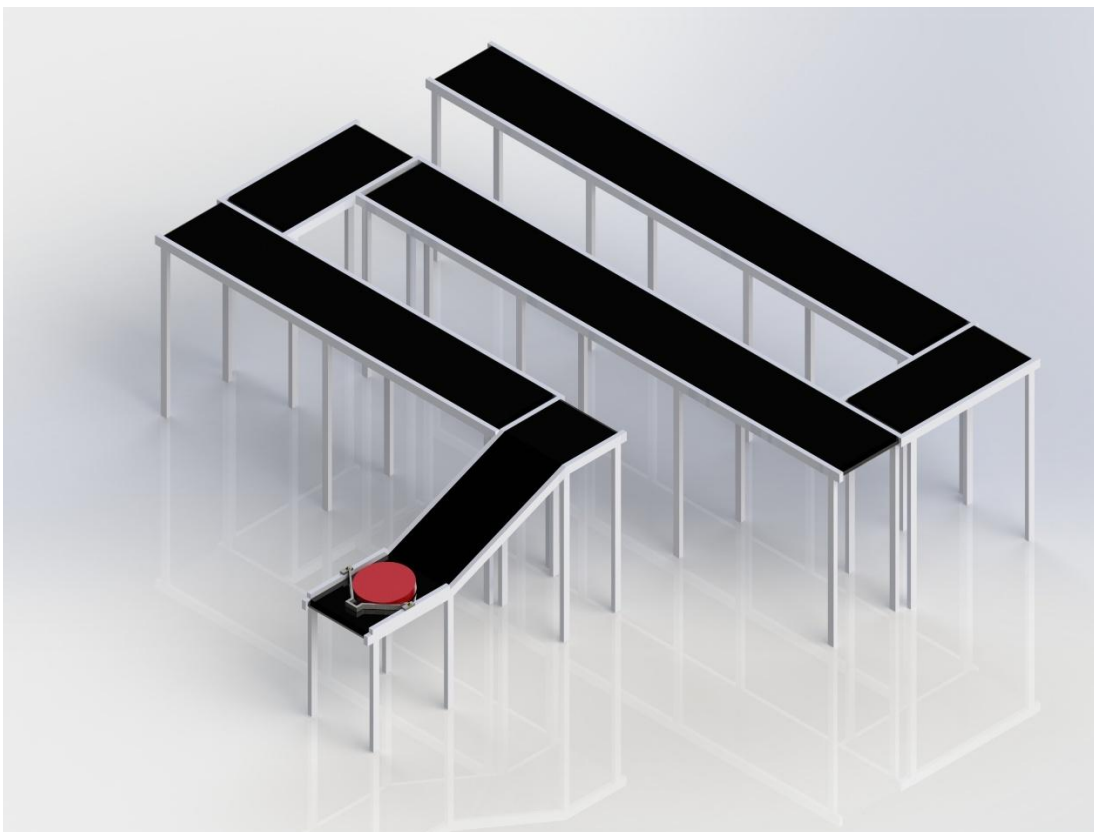

Conveyor with inclined part

Appendix 6 List of companies chosen for research

Russia

1. PotokovyeLinii
2. ConveerMash
3. Inger
4. Conveers
5. FlexLink
6. Conveyor.rus
7. ConveyorSystems
8. Trak-On

Finland

1. Algol Technics Oy
2. Orfer Oy
3. Finn-Metacon Oy
4. Fenno Water Ltd Oy
5. OEM Automatic Oy
6. Norcar-BSB Oy Ab
7. Finn-Packers, Finland
8. Putkiaivot Premet Oy
9. Lastusen Metallityö Oy
10. MAT Service Oy
11. BF Conveyor Oy Ab
12. SICK OY
13. SSI Schäfer Finland

Estonia

1. tb Technobalt
2. APL Production AS
3. Tech Group AS

Lithuania

1. EQUINOX

Poland

1. JORDAN matcon Sp. z o.o.
2. Promag
3. Haberkorn
4. Conlog
5. Global Engineering
6. Logisystem
7. Flexlink

Sweden

1. ASM
2. MHmodules
3. Hanter it
4. Flexlink
5. Fredriksons
6. Systemservice
7. AVT Industriteknik
8. AH-automation
9. Bandtec AB I Kalmar

Germany

1. ALTRATEC
2. Modular Automation

Specification for the conveyor line

Conveyor length	~ 9950 mm
Application:	Production and machining industry
Material of moving workpieces:	Steel, alloy steel
Loading capacity:	50-60 kg per 1 meter of belt
Belt material:	high resistant to surface scratches due to sharp edges
Pulley diameter	30-50 mm
Total amount of conveyor tables:	6 tables with separate motors
CPU:	single CPU unit
Sensor system:	optical or inductive
Height of the conveyor:	~1000mm

Dimensions of workpieces

- Round shape
ø 90-230 mm; thickness - 20-35mm
- Squared shape
35x35x120 mm



Centering device