



# **OPTIMIZING BELT CONVEYOR MANUFACTURING**

**Thesis**

**Honghong Chen**

**Degree Programme in Industrial Management**  
Project Management

Accepted \_\_\_\_ . \_\_\_\_ . \_\_\_\_ \_\_\_\_\_

**SAVONIA UNIVERSITY OF APPLIED SCIENCES, BUSINESS AND ENGINEERING, VARKAUS**  
Degree Programme  
Industrial Management

Author  
Chen Honghong

Title of Project  
Optimizing Belt Conveyor Manufacturing

Type of Project	Date	Pages
Final Project	17.12.2010	61

Academic Supervisor	Company Supervisor	Company
Heikki Salkinoja	Heikki Salkinoja	Chaohu Machinery Manufacturing Co, Ltd

Abstract

This final year project was carried out at a Chinese company, Chaohu Machinery Manufacturing Co, Ltd, which produces all kinds of conveying equipments for all walks of life. Chaohu Machinery Manufacturing Co, Ltd was established in 1990, and is located in Anhui Province, the southern part of China.

The purpose of this project was to provide a comprehensive knowledge of the basic production process theory of manufacturing belt conveyors. The project focuses on choosing the right conveyor belt and suitable components to ensure manufacturing of high-quality belt conveyors. The existing problems of the idlers and belt conveyor are pointed out and proper solutions are given to make them have a longer service life.

The final aim was to create an automatic idler production line to achieve large scale production, of idlers which enhances both the efficiency and productivity. In order to help the company to get a larger sales market, a plan of designing a belt conveyor for extreme cold weather conditions was carried out, but further research still is needed to make it come true.

Keywords  
Belt conveyor, idler, pulley, production line.

Confidentiality

# CONTENTS

ABSTRACT	
TERMS AND DEFINITIONS	
1 INTRODUCTION .....	5
2 INTRODUCTION TO BELT CONVEYOR.....	6
2.1 Basic principles .....	6
2.2 Belt conveyor - past and applications today .....	8
2.3 Types of a common belt conveyor .....	9
2.4 The structure of belt conveyor .....	10
2.4.1 Conveyor belt .....	10
2.4.2 Driving device .....	13
2.4.3 Return pulley .....	16
2.4.4 Idler .....	16
2.4.5 Framework .....	20
2.4.6 Tension device .....	20
2.4.7 Brake device .....	22
2.4.8 Cleaning device .....	22
2.5 To use the right conveyor belt .....	23
2.6 Idler manufacturing .....	25
2.6.1 Structure and lifetime of idler .....	25
2.6.2 Manufacturing of idler bearing block .....	26
2.6.3 Machining of the shaft .....	28
2.6.4 Machining of idler tube .....	28
2.6.5 Assembling and welding of idler .....	29
2.7 Existing problems of the idler and solutions .....	30
2.7.1 Main reason for improvement.....	31
2.7.2 Improvement .....	32
2.7.3 Results of improvements.....	33
3 INSTALLATION AND MAINTENANANCE OF THE BELT CONVEYOR.....	35
3.1 Installation of the belt conveyor.....	35
3.2 Maintenance of the belt conveyor .....	37
4 SAFETY OF USING A BELT CONVEYOR.....	39
5 WORKING METHODS AND RESULTS .....	41
5.1 Manufacturing idlers in large scale .....	41
5.2 Solutions to current existing problems of belt conveyor.....	44
5.2.1 Conveyor belts run-off center.....	45
5.2.2 Spillage of conveyor belt .....	46
5.3 Designing of a belt conveyor for extreme cold weather.....	49
6 CONCLUSIONS .....	53
REFERENCES .....	54
APPENDICES .....	56

## **Terms and definitions**

Bearing block – The block or housing that contains or supports a bearing.

Bed Section – The conveyor frame that supports the conveyor's belt, drive, end units, carrying surface/rollers, etc.

Belt Cover – A rubber or PVC coating applied to a conveyor belt to protect the belt carcass and/or provide special carrying capacities for the belt.

Belt Sag – Lack of tension or tautness in the conveyor belt that causes it to droop in areas between supporting members.

Belt Tension – The results of force applied to the conveyor that causes or trends to cause stress or stretching of the belt. All belts must be tensioned to some extent to provide proper driving force and tracking.

Belt Tracking – The path followed by the belt as it runs on the conveyor and around the conveyor pulleys.

Belt Wrap – The amount of contact between a belt and a pulley, or roller, measured in degrees.

Brake – A friction device used to bring conveyor components to a controlled stop and /or prevent them from moving once stopped.

Clutch/Brake - A coupling device normally mounted between a motor and a gearbox providing the benefits of a clutch as well as braking capacities. This arrangement allows a conveyor to be stopped without having to stop its motor which will improve the life of the motor.

Crown Pulley – A pulley having a face that is slightly tapered from the center to the ends, so that its diameter at the center is greater than at its ends. Used to assist in belt tracking.

Drive Pulley – The pulley that is connected to the drive gearbox by the drive chain and sprocket transmitting the rotational force provided by the arrangement to the conveyor belt. Driving force to the conveyor belt is provided by the amount of belt wrap on the drive pulley and the vulcanized lagging provided on the pulley.

Drive Sprocket – The sprockets used in the power transmission arrangement found in

the conveyor drive unit. The sprocket sizes are selected to provide some mechanical advantage and give the desired conveyor speed from a given output RPM of the gear box.

Frame – A structure supporting the machinery components of a conveyor.

Friction – Resistance to relative motion between two bodies in contact caused by the surface characteristics of the bodies at the point or area of contact, and the contact pressure.

Gravity Roller Conveyor – A series of rollers supported in a frame over which objects are advanced by gravity. Rollers are not powered by an outside force.

Head Pulley – A pulley used at the terminal end of the conveyor toward which the commodity is being conveyed.

Head end – The end of the conveyor toward which the commodity is being conveyed.

Idler Sprocket – An unpowered sprocket that supports, guides and /or changes the direction of a chain. Usually mounted on a shaft that in turn is supported by a bearing.

Power Transmission Belt – A belt that transmits power or motion from one rotating part to another.

Power Transmission Parts – Those parts or components by which power produced by the motor or gearmotor is conducted and applied to run the drive pulley of a conveyor.

Pulley – Consist of a steel tube with end plated, taper lock mounting hubs and bushing, and a steel shaft. Used for drive pulley, end pulleys and take-up pulleys.

Take-up Device – The arrangement of parts that applies tension to the conveyor belt, consisting of a take-up pulley or roller and a means for adjusting its position to create longitudinal stress in the belt.

V-belt – A drive belt having a trapezoidal cross section for operation degrees over grooved sheaves. Its shape permits wedging contact between belt side and grooves walls for transmission of power.

## 1 INTRODUCTION

This final year project was carried out in a Chinese company, Chaohu Machinery Manufacturing Co. Ltd and the aim of this thesis was to point out that a better method to optimizing belt conveyor manufacturing process should be utilized by this company.

Chaohu Machinery Manufacturing Co., Ltd was established in 1990 and has directed its effort and energy into producing different solutions for mining, transporting requirements of conveyor equipment. The operation philosophy “Quality moulds brand, integrity wins the world” is held by the company, and a perfect and concentrated development direction is insisted on. Personalized designing products are paid attention to and the technique is innovated constantly to meet the raising requirements of customers. After 20 years’ development, Chaohu Machinery Manufacturing Co., Ltd has obtained a good reputation in all walks of life via solid strength, advanced skill and sound quality of products.

The main product of Chaohu Machinery Manufacturing Co., Ltd is belt conveyor, which is a kind of simplified conveying equipment with the features of big transmission capacity, low operating expense, and a wide range of applications, etc.

Generally speaking, belt conveyor is a GP belt conveyor, which stands for General Purpose. It has been widely used in metallurgy, mining, chemical industry, power stations and so on for conveying all kinds of bulk and block material with bulk specific weight of 0.5-2.5 tons per cubic meter. The belt conveyor can also be used in costume, toy, and brewing etc line production.

## **2 INTRODUCTION TO BELT CONVEYOR**

Belt conveyor is constantly operating transporting equipment which is mainly used to convey mass bulk material like mineral, coal, sand, etc in powder or block as well as packed freight in metallurgy, mining, building heavy industries and transportation industry. Belt conveyor is the most perfect conveying equipment for coal-mining, because it can work efficiently and continuously. Compared with other transporting equipments, belt conveyor not only has the merits of long conveying distance, big capacity, constant working operation, but also with the features of operational reliability, easy to have automated and concentrated control. Belt conveyor has become the key equipment especially for high-output and high-efficiency coal mine.

In the first chapter, the basic principles of the belt conveyor are illustrated and something about belt conveyor's past and applications today is told. After that, the basic components of the belt conveyor are explained. It is also explained what they do and how they work. Then the manufacturing processes of the idler and pulley in Chaohu Machinery Manufacturing Co., Ltd are presented.

### **2.1 Basic principles**

To start with, it is essential to understand what a belt conveyor is. As we all know, a conveyor can move material, like cardboard boxes, wood boxes and plastic boxes. This is called gravity conveyor (Figure 1). When the conveyor can move boxes up against gravity, down or horizontal, it is a belt conveyor, whose moving belt is controlled by electric power (1, p.3).

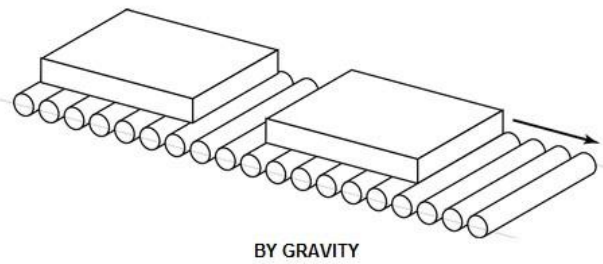

Fig 1 Gravity Conveyor (1)

A belt conveyor is a machine with a moving belt, and the machine is made with these parts: a conveyor bed, which comes in variable sizes, lengths and widths; a pulley is like an iron pipe. Pulleys are put on each end of the bed and they are as wide as the conveyor bed. Each pulley has a steel shaft through it, the shaft turns on a bearing, and the pulley turns with the shaft. Bearings are used to keep the pulley shaft and the conveyor from rubbing together; a conveyor driver is made up of a motor, a speed reducer and a drive pulley (Figure 2). The drive pulley is driven by the motor. Two sprockets are put on both of the drive pulley shaft and the motor so that a chain can be put around the drive pulley sprocket and the motor sprocket. The chain moves when the motor is started and the drive pulley is turned by the chain. But, because a motor turns very fast (1750 rounds per minute), a speed reducer must also be used and it is put between the motor and the drive pulley. The motor is connected to the reducer with a V-belt (like the fan belt in a car) or a “C” Face coupling, the reducer is connected to the drive pulley with a chain, so the drive pulley turns more slowly. (1, p.6-9)

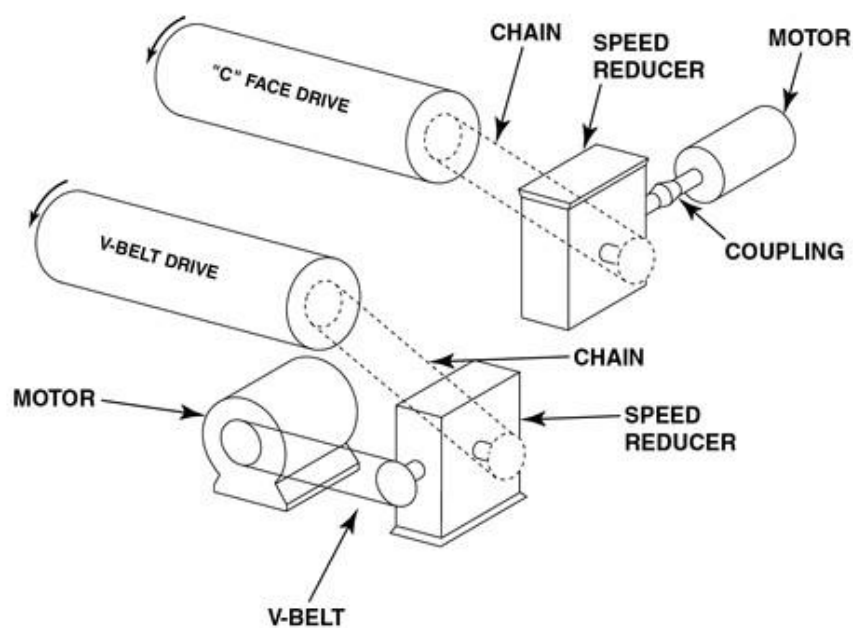

Fig 2 Conveyor drive (1, p.7)



In real life, the motor and reducer are put under and within the conveyor bed so as to take up as little space as possible. A tail pulley is located at the tail end of the conveyor and it turns freely. After the conveyor belt is put around, the drive pulley turns and moves the belt around and around. But it's dangerous to have the belt hang down under the conveyor bed, so small rollers are put into the conveyor bed to hold up the belt. They are called return idlers. Finally, a belt conveyor is made (Figure 3). (1, p.12)

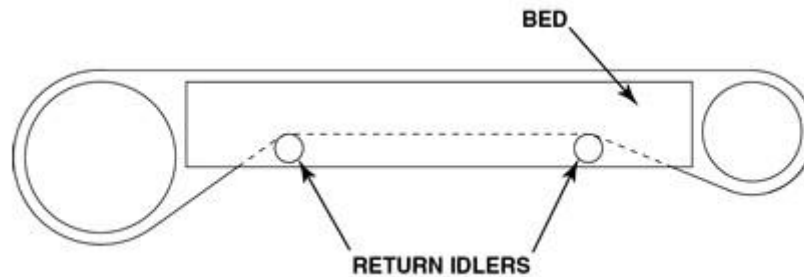

Fig 3 Belt conveyor (1, p.12)

## 2.2 Belt conveyor - past and applications today

Belt conveyor is kind of simplified transportation equipment; it appeared in A.D. 1800, and it came to be used in the 1860s. In the very beginning, the pulley used in the belt conveyor was a solid cylinder which was made by casting. Because of the heavy weight and power consumption, few people pay attention to it. It was not until the 1890s when the pulley was changed into a hollow cylinder that the belt conveyor set its strength out. (2, p.4)

Nowadays, the belt conveyor has the features of big transferring capacity (30000t/h), long conveying distance, easy maintain, noise reduction, low energy consumption, reliability and safety to use and so on. At present, the conveyor system is developed in the direction of automation control by which man made operating mistakes can be reduced. Although the structure of the belt conveyor is simple, enough attention should be paid to make sure the belt is installed correctly in the centerline of the driving shaft and driven shaft, or the belt may be offset or even get loose, which can cause the reduction of belt service life. (2, p.4-5)

The belt conveyor has defects, but it has become indispensable in all walks of life because of its merits. Belt conveyor is playing a big role in Household Appliance Industry, Electron trade, Machinery Industry, Tobacco Industry, Paper Mill, Posts and Telecommunications, and Food service industry. The belt conveyor is called the king of belts.

### **2.3 Types of a common belt conveyor**

A common belt conveyor can be divided into three groups in the following way:

- (1) A commonly used belt conveyors. It is for common transferring use, like in coal preparation plant in ground.
- (2) A ribbed belt conveyor. There is a projecting thread on the working surface of the belt, and the working angle can reach to 35 degrees.
- (3) A wire cord belt conveyor. The tape of the conveyor is just used for loading material, and the belt is driven by the wire cable, so the conveying distance is long. In China, it can reach as far as 2500 meters. (3, p.2)

According to the installation method, the belt conveyor can be grouped as a fixed belt conveyor, a mobile belt conveyor and a telescopic belt conveyor. The fixed belt conveyor is usually applied under the circumstance of big transportation volume and long operating time, its bed and components can't be dismantled or moved randomly. A mobile belt conveyor is used in the occasion of a short conveying distance, small transportation volume and changeable construction plant. It is light in weight, and can be moved easily because of the wheels or tires. A telescopic belt conveyor can be use when the transferring distance is changeable since its bed consists of several short beds, and these short beds are connected by bolts or pothooks. (3, p.2)

## 2.4 The structure of belt conveyor

Belt conveyor is mainly composed of a conveyor belt, idler and support, a driving device, tension apparatus, brake apparatus, cleaning device and so on (Figure 4). (2, p.6)

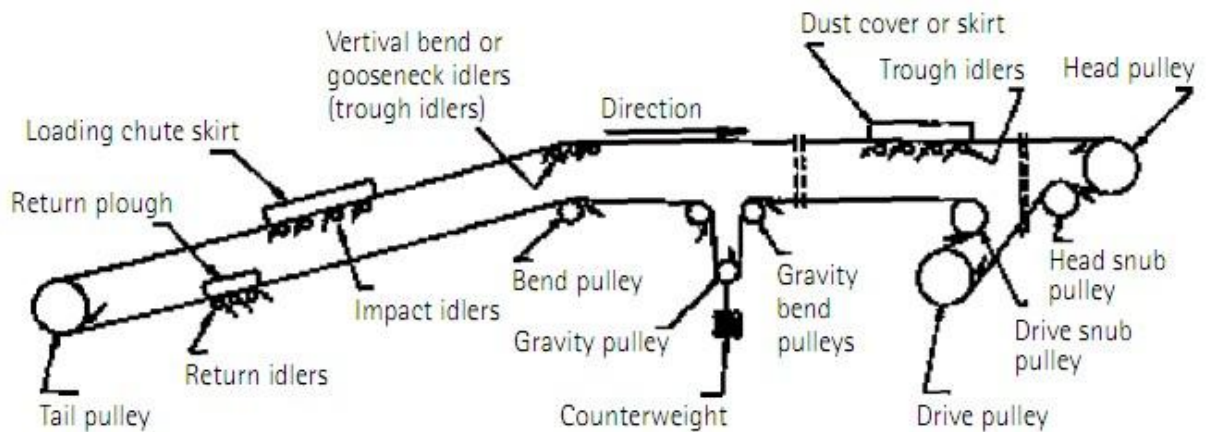

Fig.4 Belt conveyor (4, p.8)

### 2.4.1 Conveyor belt

Conveyor belt is the most expensive but the least durable part of a conveyor. During the working process of a conveyor, the loading effect with distinctive nature and in variable size is acted on the belt, which makes the belt in a complex state of stress. There are several kinds of typical damage forms of the belt: the working surface and edges are worn, striking, tearing and peeling caused by the impact of big ore particles; belt core suffers from fatigue due to alternating bending via the idlers, the intensity index decreases and ageing because of the effect of environment medium. (3, p.3) Suggested by the calculation, the conveyor belt expenses account for half of that of all the equipment of a conveyor. Hence, choosing a suitable belt according to the conditions where the conveyor will be used, enhancing maintenance and management during the working process are essential to prolong the belt's service life, to boost the conveyor's efficiency as well as to reduce the cost of manufacturing the conveyor.

Conveyor belt has two kinds of categories: rubber belt and plastic belt. Rubber belt is normally suitable for the working temperature of  $-10^{\circ}\text{C}$  to  $+40^{\circ}\text{C}$ , and the material

temperature cannot be over +50°C, or the belt's elasticity will disappear. If the temperature is too low, the belt will become hard and have cracks. A fireproof belt should be used when the temperature is higher than +90°C while a cold-proof belt is utilized when the temperature is from -15°C to -55°C. (3, p.3)

A rubber belt has a wide range of applications in real life. It is made up of belt core and covering rubber. Belt core is the framework of a belt, it is used to stand loading, to pass tractiveforce, as well as to endure the impact force. The belt core of a common belt is made up of layers of coated canvas; the material can be fabric like cotton, vinylon, nylon.etc or blend canvas, or even be a heavy cloth integrally braided with chemical fabric. Covering rubber is the protecting layer of the belt core, whose function is to prevent the belt core from impacts, wear and corrosion caused by the conveying material, so as to lengthening the working life of the belt. Covering rubber has parts, the upper covering and down covering. The upper covering rubber is the carrying surface that contacts the transferring material, its thickness is 2-6mm. The down covering is the running surface that is contacted with support idlers, its thickness is 1.5-2mm. the covering rubber of the belt's two side surfaces is called edge rubber, which has a high wear-resistance, since the sides surfaces are readily to be worn out. As for the common use rubber belt, the recommended thickness of the covering belt is listed in table 1. (3, p.4-5)

Table 1 The recommended thickness of rubber belt for covering belt (modif.3, p.5)

Material features	Material names	Covering rubber thickness[mm]	
		Upper thickness	Down thickness
Medium, small particle size or material with low wear ability	Coke, coal, dolomite, limestone, sand, etc.	3.0	1.5
Lumpiness less or equal to 200mm or material with high wear ability	Tattered ore, ore dressing product, rocks, oil shale, etc.	4.5	1.5
Block material with high wear ability	Block iron ore and oil shale.	6.0	1.5



		[mm]	s [mm]	s [mm]	thicknes s [mm]	belt core [N/cm]	[N/m]
Comm on types	400	9	3	2	4	2198	44.5
	500						55.6
	650						80
	800						98.1
		10			5	3296	
High power type	800	11	3	2	6	4905	106

For the sake of easy manufacturing and transporting, the conveyor belt is usually made in the length of 100-200m, so it needs to be joined when it is necessary. In terms of rubber belt, there are mechanical joining and hot and cold vulcanized joining methods. The plastic belt has mechanical joining and plasticized joining. The mechanical joint is removable, it's harmful to the belt core, and the efficiency of the joining strength is low, 25%-60%, the service life is short, and joint hurts the pulley's surface when they come into contact. Mechanical joining is often used in short distance or mobile belt conveyor. Vulcanized (plasticized) joint is non-removable. It has the advantages of big carrying ability, long life, no damage to pulley surface, high joining efficiency (60%-95%) and so on. However, it is a complex craft. (2, p.41)

#### 2.4.2 Driving device

Driving device is the power transmitting mechanism of a belt conveyor. It is made up of an electromotor, coupling, reducer and driving pulley and so on. According to different using conditions and working requirements, the drive mode of a belt conveyor can be grouped to single-motor driving, multi-motor driving, single-pulley driving, and double-pulley driving and multi-pulley driving. (3, p.10)

Single motor and single pulley driving is adopted by a belt conveyor. The driving device is installed at the discharge point which is located at the conveyor head. When the power is big, a single motor and double-pulley driving is used, precisely, one motor has

two driving pulleys, and the two pulleys are connected by a pair of exposed gear which has the same number of teeth. (3, p.10)

In Chaohu Machinery Manufacturing Co., Ltd, motorized pulley (Figure 5) is used to tight the conveyor structure as well as perfects the image of the conveyor. Electromotor and reducer are put into a driving pulley to form a motorized pulley. Motorized pulley is appropriate for the occasion of high humidity, when there is narrow space for conveyor head and corrosion.

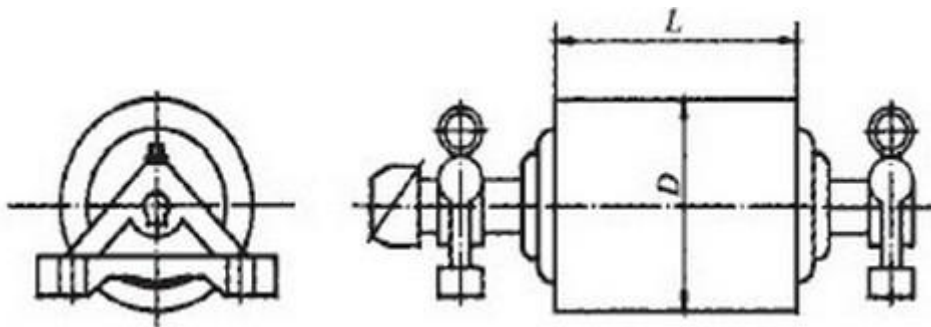

Fig.5 Motorized pulley (4, p.3)

The pulleys can be classified into two types: driving pulleys and return pulleys. The belt is driven by friction which is produced by pulley's surface and belt's surface because of the function of driving pulley, and the movement direction of the belt is changed at the same time. (3, p.12)

Driving pulley is the main component of transmitting power. In order to transmitting enough power, enough friction must be provided from the belt and pulley. According to the theory of friction transmission, the methods of increasing friction between the conveyor belt and the pulley and augmenting the wrap angle can be adopted to ensure enough driving power when a driving device needs to be chosen. Usually, when a single pulley is used, wrap angle can be  $180^{\circ}$ - $240^{\circ}$ ; when double-pulley is used, the wrap angle can reach  $360^{\circ}$ - $480^{\circ}$ . Double-pulley's driving can enhance the conveyor's traction greatly, so it is often used especially when the transport distance is long. (3, p.12)

Driving pulley's surface has glossy-faced and rubber-faced types. Rubber-faced pulley

can be utilized to increase the friction coefficient between the driving pulley and the belt, as well as to reduce the wear of the pulley. When the pulley is small, the environment humidity is low, a glossy-faced pulley can be chosen. A rubber-faced pulley can be used when the environment humidity is high, power is big, and slip is easy. (3, p.12)

Choosing a right pulley is important. When the belt of a fabric belt core is used, the pulley is chosen on the basis of the belt's thickness. The conveyor belt needs to move around the pulley repeatedly during the working process, and bending occurs. When the belt is bent, the external surface is stretched and while the internal surface is compressed, the stress and strain of each layer vary. The rubber layers have mechanical fatigue and are damaged due to the scaling when the repetitive bending reaches a certain level. The smaller diameter of pulley, the bigger the deflection of conveyor belt and the faster the scaling occurs. Therefore, the diameter D of a driving pulley is decided by the allowable crook degree of the belt, and D can be fixed by the following formula:

Vulcanized joint:  $D \geq 125Z$ ;

Mechanical joint:  $D \geq 100Z$ ;

Mobile conveyor:  $D \geq 80Z$ .

Z- The layers of coated canvas of the belt. (3, p.12)

In a standard design, the belt width has a scale relationship with the pulley is diameter, so the standard diameter can also be referenced by the following table 4. (3, p.12)

Table 4 Relationship between the belt width B and the standard pulley diameter (mm) (modif.3, p.12)

Belt width	500	650	800	1000	1200	1400
Driving pulley	500	500	500	630	630	800
Standard diameter	—	630	630	800	800	1000
	—	—	800	1000	1000	1250
D	—	—	—	—	1250	1400

The length of pulley B1 should be longer than the width of belt B by 100-200mm.



### 2.4.3 Return pulley

A return pulley has three categories:  $180^\circ$ ,  $90^\circ$  and  $45^\circ$ . The return pulley's diameter is related to driving pulley's diameter and the wrap angle that the belt has on the return pulley. Return pulley is a welded-steel plate construction with an antifriction bearing. The diameters mating relationship between return the pulley and the driving pulley is illustrated in table 5. (3, p.13)

Table 5 The diameters mating relationship between the return pulley and the driving pulley (modif.3, p.13)

B	Driving pulley's diameter	$\approx 180^\circ$ return pulley's diameter	$\approx 90^\circ$ return pulley's diameter	$<45^\circ$ return pulley's diameter
500	500	400	320	320
650	500	400	400	320
	630	500	400	320
800	500	400	400	320
	630	500	400	320
	800	630	400	320
1000	630	500	500	400
	800	630	500	400
	1000	800	500	400
1200	630	500	500	400
	800	630	500	400
	1000	800	500	400
	1250	1000	630	400
1400	800	630	500	400
	1000	800	500	400
	1250	1000	630	400
	1400	1250	630	400

### 2.4.4 Idler

Idler is the supporting device for belt and cargo of a belt conveyor. Idlers move as the belt moves so as to reduce the running resistance of the conveyor. Idlers' qualities depend on the usage of the belt conveyor, particularly the life span of the belt. However, the maintenance costs of idlers have become the major part of the conveyor's operating

costs. Hence, idlers need to have reasonable structure, durability in use, small ratio of steering resistance, reliability, and dust or coal dust cannot get in bearing, due to which the conveyor has a small running resistance, saves energy and prolongs the service life. (3, p.13)

The idler has steel idler and plastic idler types. The steel idler is manufactured of seamless steel tube. The diameter of the idler roller has something to do with the belt's width. In the design process of the belt conveyor, when the width  $B$  is equal to or less than 800mm, the idler diameter should be  $\varnothing 89\text{mm}$ . When the width is 1000-1400mm, then the roller diameter should be  $\varnothing 108\text{mm}$ . (3, p.13)

Idlers can be divided into trough idlers (Figure 6), flat idlers (Figure 7), impact idlers (Figure 8, 9) and centering idlers (Figure 10) according to the function. (3, p.14-15)

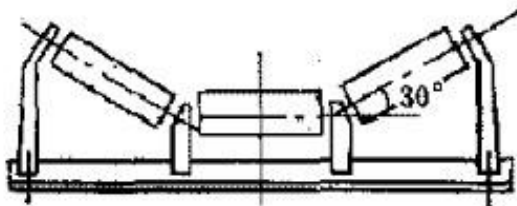

Fig.6 Trough idler



Fig.7 Flat idler

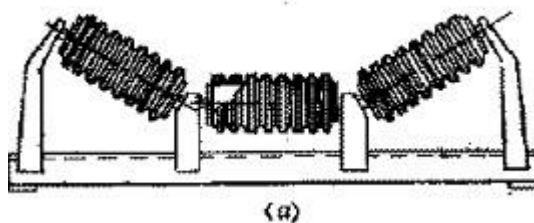

Fig.8 Rubber ring impact idler

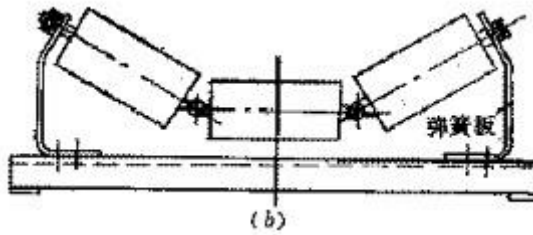

Fig.9 Spring steel impact idler

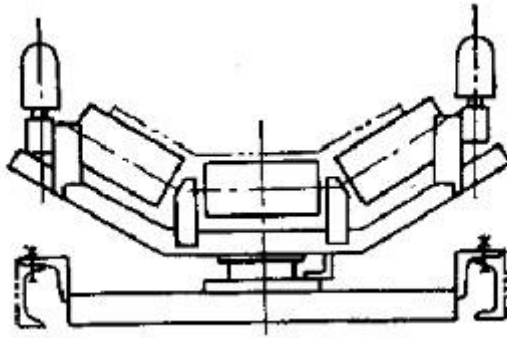

Fig.10 Centering idler

In order to enhance productivity, trough idlers are usually used as upper idlers to support the conveyor belt to transport bulk material. When the conveying material is end product, a flat idler is used. In addition, in coal preparation plants, flat idlers are chosen for both belts' upper and below idlers. (3, p.15)

In a trough idler, the angle between the inclined idler and the horizontal idler is called a groove angle. Groove angle is a significant parameter related to the conveying material. In the past time in China, the groove angle of the belt conveyor was  $20^\circ$ . In the designing of the belt conveyor, the groove angle is  $30^\circ$ ,  $35^\circ$ , and  $45^\circ$ . In the condition of the same belt's width, when the groove angle is increased from  $20^\circ$  to  $30^\circ$ , the section area of belt conveying bulk material could increase by 20%, the conveying capacity can boost by 13%, and material spatter can be reduced. (3, p.15)

The space between idlers should be able to ensure the sagging of the belt between idlers as small as possible. The belt sagging of adjacent idlers is no more than 2.5% of the idler spacing. The belt's upper idler spacing can be seen in table 6. Down idler spacing usually is 3000mm or two times of upper idler's spacing and at the receiving point, the

idler space should be 300-600mm. The upper idler space of convex curved section is half of that in horizontal section. The distance from conveyor's head pulley's centre line to the first trough upper idler can be 1-1.3 times of the upper idler's spacing, while the distance from tail drum to the first idler should be no less than the upper idler spacing. (3, p.15)

Table 6 upper idler's space (modif.3, p.15)

Packing density $\delta$ [t/m <sup>3</sup> ]	Belt width B [mm]					
	500	600	800	1000	1200	1400
	Upper idler space $l_0$ [mm]					
$\leq 1.6$	1200		1200		1200	
$> 1.6$	1200		1100		1100	

At the belt's receiving point, impact idler must be installed to reduce impact so as to protect the belt. The structure of impact idler is similar to common idler. There are rubber ring types and spring steel types. Rubber ring type is just to cover several rubber rings to the tube and spring steel is the idler basement which has elasticity to buffer the impacting of the material. (3, p.16)

To avoid and conquer the off-tracking of belt, one trough centering idler is set after every 10 trough idlers at the heavy load point of the belt. At the return empty section, one flat centering idler is set after every 6-10 down idlers (Figure 11). (3, p.16)

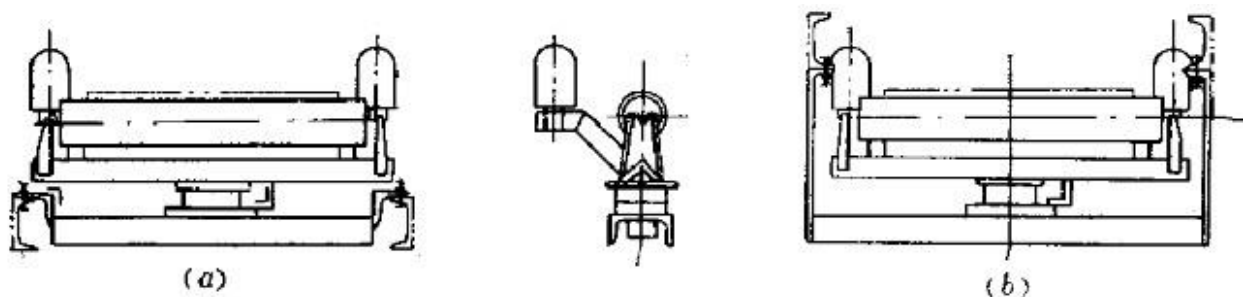

Fig.11 flat centering idler (3, p.16)  
(a) - flat upper centering idler; (b) - flat down centering idler

### 2.4.5 Framework

The framework of a fixed belt conveyor is a structure welded of angle iron and trough iron. The framework can be grouped as drive frame, end frame, middle frame and driving device frame. (3, p.16)

Drive frame is used to install driving pulley and return pulley (Figure 12a), its side is installed together with a driving frame. A tail drum is set up on the end frame (Figure 12b); the structure of end frame has something to do with the adopted tension device, so the end frame should be chosen by the tension device. Middle frame is for the installing of upper and down idlers; it is assembled by pieces of frame (Figure 12c). Two ends of the middle frame are connected with a drive frame and end frame respectively. The width of the middle frame is 300-500mm bigger than that of the belt, and the height of the middle frame is approximately 550-650mm. (3, p.16)

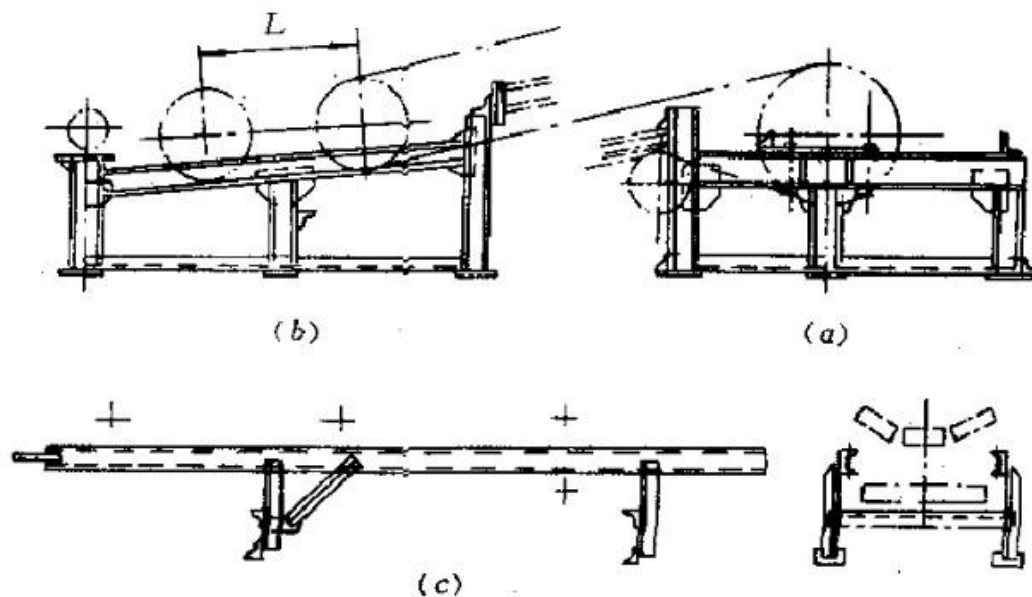

Fig.12 Framework of belt conveyor (3)

### 2.4.6 Tension device

The effect of belt conveyor's tension device is as follows:

- (1) To make the belt have enough initial tension, to ensure the friction between the belt and the driving pulley and to have a certain friction reserved.

- (2) To compensate the extension of traction members during the working process.
- (3) To strict belt sagging between each supporting idlers so that the conveyor can run regularly.

Tension device has three kinds of structure: a screw-type (Figure 13a), a car-like type (Figure 13b) and a vertical type (Figure 13c). (3, p.18-19)

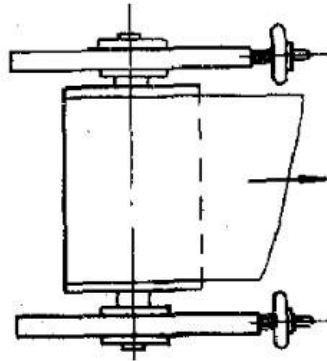

Fig.13a Screw-type

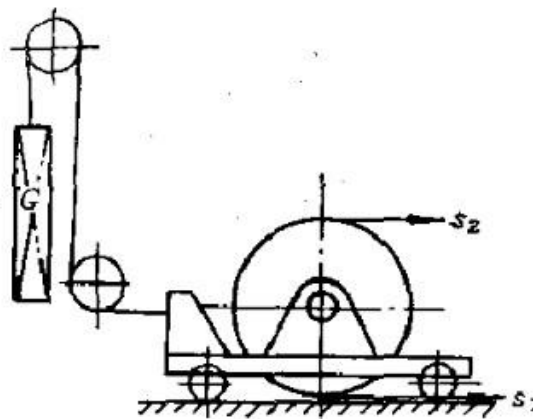

Fig.13b Car-like type

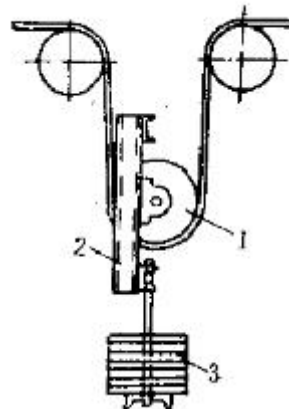

Fig.13c Vertical type

1-pulley 2-frame 3-hammer

### 2.4.7 Brake device

When the belt conveyor is used to transport material aslant, to avoid inversion or slip because of a fully load which makes the machine halt, when the average angle is more than  $4^\circ$ , a backstopping or brake device should be added. (3, p.20)

There are variable kinds of backstopping and brake devices in the belt conveyor. Different types of backstopping or brake apparatus should be utilized according to the specific using conditions. In standard design, there are the belt brake, the roller brake and the hydraulic solenoid valves brake. (3, p.20)

### 2.4.8 Cleaning device

When the belt's working surface bypasses the unloading drum, it is impossible to clean the scattered material completely, especially when the material is moist. If this residual material is not swept away, belt is easily broken due to the extrusion of the residuals when it passes the return pulley or idlers. Hence, the cleaner is meaningful in prolonging the using life of the belt. (3, p.21)

A spring cleanser (Figure 14) is often used for the belt conveyor. The rubber scraper of the cleaner is compacted on the belt surface by a spring and a screw to clean residual material. The spring cleanser's structure is simple. (3, p.22)



Fig.14 Spring cleanser (5)

A non-loaded cleanser (Figure 15) should be used at the return belt which is before the

tail return pulley to clean the residual material on the non-working surface.



Fig.15 Non-loaded cleanser (5)

## 2.5 To use the right conveyor belt

One of the most common problems in an under-performing conveyor system is a belt that inappropriately matches to the structure and affects the efficiency and belt life of both systems. While the urge may be strong to specify a “stock” belt for cost reasons, understanding a few basic principles of belt/structure compatibility is essential to achieve an optimum system performance. Without it even a new material handling system can be doomed to inefficiency and lost production.

The rated strength of the belt is expressed as PIW, an abbreviation for Pounds per Inch of Width. This rating is based on the type of ply material, number of plies, and if it is steel cable belt, the size of the cables. The higher the rated tension of the belt, the more critical the compatibility of the belt and structure becomes. (12, p.1)

For instance, a 3-ply belt may have each ply rated at 110 PIW, which translates to a 330 PIW belt. This is the maximum rated tension at which the belt can be operated without damage. Exceeding the rated tension of the belt will likely cause breakage, excessive stretch, splice failure, and belt cupping. Factors that affect the rated tension are belt length, width, material, angle of incline, and parasitic drags, such as the size and quantity of rolling components, belt cleaners, and length of transition sealing systems. (12, p.2)



The minimum bend radius of a conveyor belt is determined by the number of plies, whether it is steel or fabric reinforced, the ply material, rated tension of the belt, and thickness of the top and bottom covers. Damage such as ply separation or top cover cracking can be caused by bending the belt over a radius that is too small. Larger pulleys may be required when installing a thicker belt on a system that was designed for a thinner one to prevent damage to the conveyor belt. This is a common mistake that often occurs if some type of belt damage is apparent, as the tendency is to place a thicker belt on the system to make it last longer. (12, p.4)

Conveyor belts have the ability to be formed into a trough by idlers, which allows the belt to carry more material. However, all belts also have a maximum trough angle, determined by the type of carcass, its thickness, width and tension rating. Exceeding the trough angle of a belt can cause it to permanently deform into a cupped position, which makes sealing and cleaning difficult and tracking virtually impossible. Exceeding the belt troughing capability can also damage the top and bottom covers or the carcass in the idler junction area. (12, p.7)

To form a trough, a belt is pushed into a cup shape by the troughing idlers, but the belt must travel across the terminal pulleys (head and tail) in a flat position. As the belt leaves the tail pulley, the outer edges are stretched more than the center as it travels around the idlers. If this stretch occurs too quickly, the carcass, top cover, and bottom cover may be damaged. (12, p.7)

The top and bottom rubber cover of the belt serve to protect the carcass and it is expressed as a ratio. There is a tendency for belt manufacturers to make the top cover thicker for longer life, while making the bottom cover thinner to reduce costs. However, as rubber ages, it also shrinks. If the top cover is much thicker than the bottom cover, it will shrink more than the bottom cover, curling the edges of the belt upward (cupping). If cupping occurs, an analysis must be performed to determine the true cause(s). (12, p.8)

A conveyor belt must be compatible with the system into which it is installed. Specifying a belt without understanding the important characteristics can reduce efficiency and belt's life, and it's recommended that all parameters of the belt and structure are fully considered prior to selection. A complete review of the system is a good way to ensure that the belt used in the system is the right choice. If the belt supplier cannot provide all of the properties discussed here, then you should probably find a more knowledgeable supplier.

## 2.6 Idler manufacturing

Idler is a small part of a belt conveyor, but to manufacture a high-quality one is not an easy job. In this chapter, the process of manufacturing an idler is described in details.

### 2.6.1 Structure and lifetime of idler

An idler is made up of shaft, sealing, bearing housing, steel tube, and bearing (Figure 16). The form of idler's sealing is the major design point of an idler, which ensures that the idler is dust-free and be water proof. Currently, labyrinth style sealing is used. (6, p.1)

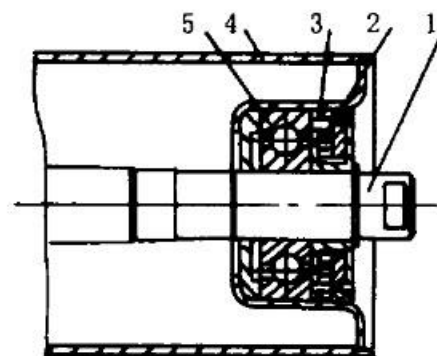

Fig.16 Idler structure (6)

1-shaft 2-sealing 3-bearing housing 4-steel tube 5-bearing

Idler's lifetime is decided by the shaft's lifetime, so idler's service time is related to the following factors:

(1) Load and velocity of the belt conveyor

- (2) Lumpiness and impact effect of the conveying material
- (3) Continuous operation time
- (4) Corrosion of the material and environment
- (5) Production and maintenance condition (6, p.2)

If idlers have the same structure but different lifetimes, then the reason can be imputed to manufacturing, which is often neglected when idler's lifetime is calculated. To make sure that the idler is working in an ideal state is the responsibility of every manufacturer. In the manufacturing process, concentricity error of the bearing at idler's both ends and external circular beating of the idler are in the range of allowable value. Meanwhile, clearance of the idler cannot be ignored. (6, p.2)

### 2.6.2 Manufacturing of idler bearing block

The quality of bearing housing has direct effect on the assembling accuracy of the bearing. The dimensions of  $H$  and  $d$  are essential to the bearing block (Figure17), the value of  $H$  affects the bearing's axial locating accuracy when assembled, and value  $d$  is directly related to the match up accuracy between the bearing housing and bearing. (6, p.2)

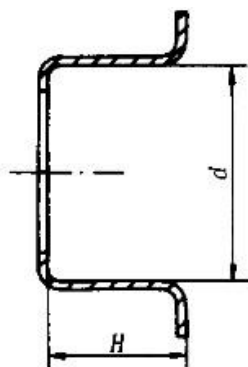

Fig.17 The bearing housing of idler (6)

The stamping of bearing housing is a material stretching process. Stretching procedure should be fixed according to the different shapes of the bearing housing, the ultimate tensile strength of the material cannot be exceeded by the inner strain of the steel during every stretching process, but the ductility of the material should be taken good use of.

The factors that affect the bearing housing's machining quality are:

- (1) Raw material. The steel plate for stamping bearing housing needs to meet two requirements. One is mechanical behavior, it must have sound strength and elongation. 08A1 is adopted by most factories in China, whose elongation is more than 35%. The other one is the thickness tolerance of the steel plate which should be better in  $\delta^{0}_{-0.05}$ , cold-rolled sheet is required.
- (2) Stamping equipment. High quality of punching machine is the prerequisite of guaranteeing high quality product. Imported crankshaft punch is recommended, which can control speed and process precisely.
- (3) Stamping die. Stamping die is designed according to the punching process flow. The quality of the die should be good, and recommended material is Cr<sub>12</sub>Mo, whose surface hardness is HRC62. Chrome is plated when the die works interruptedly while titanium is plated when the die works continuously, which makes the die wear resistant and long service life, and most importantly, the finished bearing housing has stable quality.
- (4) Punching oil. The using of punching oil is helpful to enhance the metal fluidity of cold reduction procedure, to prolong the using life of mould, to increase the surface finish of bearing housing, and to prevent bonding while cutting and cold welding as well. Therefore, the selection of punching oil should be attached high importance by the manufacturers.
- (5) Stamping pulling speed. Only if the same stamping speed of each work piece is consistent in the same working procedure can the same lattice deformation during pulling metal fluidity be guaranteed, and impact fatigue crack be avoided.
- (6) Rationality of stamping procedure. Bearing housing's stamping process is the metal fluidity process of punching steel, a rational technology is formed by testing,

especially the last reshaping which affects the size and surface roughness of the products directly. (6, p.2)

### **2.6.3 Machining of the shaft**

The machining of the shaft can be done in four steps.

- (1) Cutting of the shaft. If the length of the shaft is used as an axial criterion when assembling an idler, then the length L is very important. If there is a big error, the bearing cannot be located. The best machining method is to use a circular saw to cut, which can control cutting length automatically.
- (2) Milling grooves. This should be done on a special milling machine.
- (3) Processing center hole. If the centre bore is as the concentricity criterion of assembling, it should be machined on a good lathe, not just a common drilling machine. As for a short shaft, a baby lathe can be the best choice, which has little equipment investment but high efficiency.
- (4) Machining retaining circlip slot and chamfering of shaft ends. Providing that the shaft has accurate cutting length, the machine of retaining circlip slot which is based on the two ends of the shaft could be easy, a long shaft can be processed on the lathe while a short one on the baby lathe. (6, p.2-3)

### **2.6.4 Machining of idler tube**

The processing of idler tube has cutting, boring holes on the two ends and chamfering both inside and outside working steps. Currently, the cutting has three methods:

- (1) Hobbing. Advantages: high efficiency, accurate linear dimension. Disadvantage: big cutting deformation.
- (2) Saw cutting. A saw machine can cut steel tube with dimensional accuracy after being transformed by electronic control and measure, but has low efficiency compared with hobbing.
- (3) Cutting on lathe. It is an easy manufacturing method without special purpose

machines. Low efficiency, rotating speed should be controlled while cutting to avoid bending deflection in lengthwise for long steel tube in the machining process. (6, p.3)

### **2.6.5 Assembling and welding of idler**

Idler's quality is affected directly by the assembly of idler, which is the most vital procedure in the idler manufacturing process. The assembly procedure decides the parameters of relative position of all the components, concentricity error of the bearing on the two ends of the idler, concentricity error between the shaft and the steel tube as well as the circular run-out of the finished idlers, etc. It is important to choose a right assembly procedure to raise the precision of those parameters, and the correctness of the assembly procedure is mainly reflected on the positioning option of procedure, clamping and assembling of a work piece. (6, p.3)

The radical locating of idler assembly is based on the ex-circle of idler steel tube, and high quality of idler steel tube is a necessary prerequisite of producing a high quality idler. Usually, further machining is not done on the ex-radius of the idler steel tube, which means there is no change in the tube's roundness, so the ex-radius of the idler tube is used as the criterion of idler assembling although error exists. In that case, the fixed external circular beating of idler is close to that of the end idler. External circular beating is an important parameter of showing the idler quality property, which affects idler's dynamic moment of inertia and dynamic balance, and then influences the starting efficiency of the overall unit and the additional load of the idler itself when it is operating, and finally the idler's use life is shortened. (6, p.3)

There are two kinds of rigging positions for idler steel tube and bearing. The most commonly used one is that the axial locating of the shaft is based on the size of the retaining circlip, then the axial machining accuracy of the tube can be dismissed. In that case, there is no need to do adjustment in axial when assembling, radical locating is

completely out of the constraint of tool standard. The concentricity of bearing, bearing and tube both depend on the steel tube's roughness, finished idler's manufacturing quality can be ensured once the roughness of the steel tube meets the requirement. (6, p.3)

Spring clamping is recommended when assembling and welding the idler. For instance, pneumatic spring.

Advanced structure design which is fit in processing condition is needed in idler manufacturing, high quality of raw material and correct machining method are the foundation of making quality stabilized idlers.

## **2.7 Existing problems of the idler and solutions**

Belt conveyor is widely used in industrial and mining enterprises, and idler is an important part of the belt conveyor, usually made of seamless steel casing. In order to save materials and reduce costs, pipe joints can also be done using the shell, but the welding joints are higher, so as not to scratch tape. Now PVC pipe, glass, steel, rubber, ceramic tube are also used as the shell, they own the advantages of corrosion-resistance, low density. Belt conveyor's lifetime is directly influenced by the idler's quality:

- (1) Conveyor's operating condition is determined by the radial run-out index of the idler
- (2) The using environment and condition of the conveyor and service life of idler are in turn determined by the protective properties of the idler
- (3) Conveyor's operating power is determined by the dynamic spin resistance of idler
- (4) The overall performance of idler determines not only the length of use life of its own, but decides the life of the entire conveyor.

Thus, the idler plays an important role in the conveyor's working process. Therefore, to

produce a high-quality idler is an important part of the belt conveyor production process. In the idler production process, the level of idler assembling technology is the top priority factor of determining the final performance of the idler, as well as the entire conveyor's property. To produce a high-quality roller, strict control must be done from the structure, the choice of material and components and making process. The main factors that affect idler's performance are choosing of the bearing, sealing structure and way of lubricating, designing of the idler structure, material selection and comprehensive level of idler manufacturing. (7)

### **2.7.1 Main reason for improvement**

(1) Excessive wearing is one of the major factors that affect the idler's service life.

Steel parallel roller is a commonly used idler structure. The shaft, bearing and bearing boxes are installed inside the pipe. Two ends of the shaft stretch out of the pipe, and the two ends are milled into deltoid to be fixed to the conveyor frame by hanger or support while the belt is supported by the pipe. Parallel rollers are generally used as under idlers, if the conveying material is with high temperature or viscosity or cleaners are working poorly, the wearing of flat idlers is severe, bid fractional resistance will result in high transport costs. (13, p.47-48)

(2) The seal is not good.

Axial non-contact labyrinth sealing is adopted inside the idler, which is characterized with the small twisting gap formed by the inner and outer seals to achieve sealing, good non-dust effect, but poor water resistance which affects the service life of the idler ultimately. (13, p.48)

(3) Poor concentricity of the bearing housing.

Bearing housing for idler is punch forming, and it is welded to the steel tube without further processing to the fitting place. Out roundness of the stamping bearing seat or unevenness of the end plane on the fitting place, they are both easy to create different coaxial of the bearing housings after welding, which results in decreasing of bearing



clearance and rotation flexibility, increasing of rotation resistance. (13, p.48)

(4) Poor concentricity of roller shaft.

Cold-drawing axis is used as idler shaft, which is characterized by its surface roughness and dimensional accuracy can achieve requirements of the drawings without processing. They are easy to use, save labor and time. But due to the wear and tear of mould during production, instability accuracy of dimension, or even exceeding the standard size is caused, coupled with the transport effects, it could be bended easily, so the concentricity of roller shaft is poor, the bearing clearance of the idler shaft installed at both ends cannot be guaranteed, thereby the resistance of roller rotation is increasing, the service life of idler is affected. (13, p.48)

### **2.7.2 Improvement**

(1)To reduce the roller's contact area. The wall of the roller is slipped into a number of stainless steel rings and fixed by block and shaft nail to replace roller body. If it is used in the places of low corrosivity, common straight-carbon steel or nylon rods can be used to replace stainless steel to be turned into disc-wheel and be fixed on the shaft. The number of rings can be decided on according to the width of the belt. Block, screw and shaft can be made of carbon steel, and a layer of nylon fabric glued evenly to the flat idler surface can extend roller's life. (13, p.48)

(2)To strengthen the sealing of idlers. Idler sealing performance has a great impact to the life of idlers. Seal is to prevent outside dust, pulverized coal and water invading the bearings. Seals can be divided into contact and non-contact seals according to the sealing principle. The former is made of oil resistant rubber with sound comprehensive mechanical properties, high rebound resilience and wear resistance. The rubber sealing and idler shaft are combined tightly because of the interference, which solves the water resistance and dust problems effectively, it is used in the occasion of low rotating speed. The latter one, axial labyrinth seal, has an internal seal and an external seal, and the sealing can be achieved by the little curved gap which is formed by the inner and outer seal elements and it is for high rotating speed. An axial labyrinth seal has a sound

sealing effect and low resistance. The seal can be set along the axis, be loaded and be unloaded conveniently. Therefore, an organic combination of the two kinds of idlers to can be made to achieve the waterproof, dust-proof effect better. (13, p.48)

(3)To increase concentricity of bearing housing. To ensure the concentricity of two bearing housings, further processing can be done at the circumference and end face of the bearing and the fitting place of cylinder, so that bearing housing is not round or the unevenness of the barrel end face can be effectively overcome, to ensure the concentricity of two bearings by processing means. (13, p.48)

(4)To increase shaft concentricity. In view of instable precision of cold drawn optical axis and uncompensated shortcoming of different axes caused during transportation, the steel rod and stepped shaft can be used to replace the cold-drawing optical axis by means of processing to ensure the coaxial of both ends of shaft, and grinding can be done at the place of installing a bearing. (13, p.48)

(5)To improve the machining procedure. To modify the order of machining axial check ring grooves, firstly sealing and assembling, axial running number is kept out as standard requires, and then grooving, so as to avoid the problem of axial is running value becomes too big, to ensure that its axial movement value is not greater than 0.7mm. (13,p.48)

### **2.7.3 Results of improvements**

(1)Belt conveyor can run more stably and reliably, the performance is more superior, and efficiency is boosted.

(2) The service life of the idler is extended, and it is more convenient to examine and change the idlers.

(3) Material consumption is reduced significantly, transportation costs are reduced effectively. (7)

In summary, to produce a good belt conveyor idler, the assembly of bearing housing, bearing combination, and adjustment of check ring are three key procedures. In addition, even if all the processing, assembly processes have a reliable technology guarantee, exquisite adjustment and inspection should also be done in the final adjustment process, this can effectively ensure the production of a good performance and long service life idler.

### **3 INSTALLATION AND MAINTENANANCE OF THE BELT CONVEYOR**

In this chapter, the installation steps of belt conveyor are presented, and the maintenance is mentioned as well.

#### **3.1 Installation of the belt conveyor**

Belt conveyor is installed as what explained in the following:

- 1) The frame of the belt conveyor is installed, and the installing of the frame is start with the head frame, followed by all middle frames in order, last is the tail frame. Before the frame is set up, a center line is dragged along the whole conveyor, as keeping the conveyor's center line collinear is the vital condition of ensuring normal running of the belt. Hence, all sections of the frame must be aligned when they are installed, the allowable error is  $\pm 0.1\text{mm}$  for one meter of conveyor and for the whole conveyor, and the allowable error should be limited to 35mm. When each section is captured and installed, they are then joined.
- 2) The driving device is installed. When the driving device is installed, the conveyor's transmission shaft must be perpendicular to the conveyor's centre line. The centre of the driving pulley should coincide with the centre line of the conveyor, and the reducer axis should be parallel to the drive axle. Meanwhile, all the axles and pulleys should be made level. According to the width of the conveyor, the horizontal error of axle should be controlled in the range of 0.5-1.5mm.

A tension device can be installed while installing the driving device. Pulley axle of the tension apparatus should perpendicular to the conveyor's centre line.

- 3) The installation of idlers. After frame, driving and tension device have been set up,

the idler frame for upper and down idler can be installed due to which the belt has slowing turning curve, and the distance between the idler frame in the curved place should be 1/2-1/3 of that in a normal idler frame. The rotation of the idler should be flexible after be installation.

- 4) Last capture of belt conveyor. To make sure that the belt runs along the centre line of the idler and pulley from the beginning to the end, three requirements must be met when idlers, frame and pulleys are installed. First one is to ensure that all the idlers are in rows, parallel to each other and lateral level. Second, all the pulleys must be in rows and parallel to each other as well. The last, the supporting structure frame must be linear and keep lateral level. Therefore, last capture need be done to the conveyor's centre line and horizontal place after driving pulley and idler frame have been set up. Frame is fixed on the foundation or floor.

Feed and unload apparatus can be accommodated when the conveyor is fixed.

- 5) Placing conveyor belt. Belt should be first unfolded on the idlers of no-load section, and then be laid on the heavy-load section after the belt has surrounded the driving pulley. Hand winch of size 0.5-1.5t could help to place the belt.

When the belt is tensioning and to be joined, the pulley of tension apparatus should be moved to the extreme position, for which screw-type and car like type, the tension device needs to be moved towards to the driving device, and pulley need to go to the top for the vertical one. Reducer and motor should be ready before the belt is tensioned. (10, p.4)

After the belt is installed, idle commissioning is necessary. During idle commissioning, attention needs to be paid to whether there is off-tracking, running temperature of the driving parts, operating condition of idlers, contact level between the cleaning device and the belt surface. Adjustment can be done if necessary, loading commissioning can only be done after all the components work regularly. (8, p.4)

### 3.2 Maintenance of the belt conveyor

There are many reasons for conveyor failure, but regular inspection and subsequent planned preventative maintenance is always far more efficient and less costly than breakdown downtime and repair. And it should be noted that conveyor belt maintenance not only includes proper care of the belt, but also includes care and maintenance of the hardware, which includes idlers, pulley, belt cleaners etc.

The maintenance of a belt conveyor is basically the same as any equipment with moving parts and no matter how well the conveyor is designed and constructed it will require scheduled maintenance and periodic service maintenance.

A strict maintenance schedule and well-trained maintenance crew can save companies a large amount of money over the course of equipment life. The maintenance function in any operation is in charge of keeping the equipment operating at maximum productivity or capacity. Scheduled maintenance reduces downtime and ensures the efficient and safe operation of the system. A quality maintenance program begins with management and their insistence on strict routine maintenance schedule and periodic outages specifically for the overall review of the equipment.

Equally as important to the maintenance schedule of belt conveyors is that service is performed by well-trained, competent personnel provided with proper test equipment and tools. The maintenance crew should be skilled employees empowered to shut down the conveyor to make the necessary repairs.

The recommended components of a belt conveyor requiring routine maintenance and service:

Electrical: Motors - lubricate internal bearings as recommended by the manufacturer.

Safety switches check electrical connections and any signs of broken parts.

Reducers: Lubricate internal bearings and fill oil level as recommended by the manufacturer.

V-Belts: Check for proper tension and worn or cracked areas.

Chain drives: Check for proper tension and worn rollers and sidebars.

Screw Take-ups: Check for proper belt tension and remove any built up material.

Idlers: Check for free rotation and excessive worn areas, if any type lubricate as recommended by the manufacture. Remove any built up material.

Training Idlers: Check for proper alignment to belt and free rotation or excessive worn areas, if any type lubricate as recommended by the manufacture. Remove any built up material.

Pulleys: Check pulley alignment and surface of lagging if lagged. Pulley assemblies should rotate freely. Remove any built up material.

Bearings: Check for proper alignment to frame and lubricate as recommended by the manufacture. Remove any built up material.

Belting: Check for proper tension of excessive wear areas, torn, or ripped areas, if a mechanical splice check fasteners.

Belt Cleaners: Check for proper tension and wear on the cleaner blade and replace if needed to keep cleaner from rolling under. (9, p.9)

## **4 SAFETY OF USING A BELT CONVEYOR**

The increase in production quality, work productivity, the capacity of the devices and efficiency in various regions of human activity must not conflict with safety. Good common sense is the key when working on any equipment and must be used while observing or servicing equipment. Some general safety guidelines of using a belt conveyor should be observed.

Lockout/tag out all energy sources to the belt conveyor, conveyor accessories and associated process equipment before beginning any work – whether it is construction, installation, maintenance, or inspection that is directly associated with the equipment you are involved in. The use of lockout device with one key for each piece of equipment should be used. The person actually doing the work should be the only person with the key to the lockout device. Operating and maintenance personnel should become familiar with the material being handled in the system along with the location and purpose of the safety devices before being allowed to operate or work on the equipment. A belt conveyor safety training session should be a portion of a comprehensive safety program provided by the company to all employees that will be required to operate or maintain the equipment. (9, p.11-12)

All safety devices should be in a good working condition, properly maintained and easily accessible. An emergency stop switch with safety pull cords should be mounted at a proper height. The equipment should be operated at its design capacity and speed. Overloading belt conveyors result in spilled material and hazardous working conditions and premature failure of components. During and after maintenance of the equipment a safety “walk around” is recommended as a precaution for leaving tools or work material prior to starting the equipment. A formal maintenance and inspection schedule should be developed and followed for the equipment and associated safety devices. Required personnel safety equipment such as hard hats, safety glasses, and steel toe shoes should be worn when in the area of the equipment to provide any type service or work. (9, p.12)



Manual inspection, maintenance or repairs must be done at a time that can be taken out of service, properly lockout and tagged. In no case should belt conveyors or any operating equipment be serviced while in operation. Only visual inspection can be done during operation and care must be taken to be at a safe distance and not be wearing loose clothing. Inching drives provide an excellent method of visually inspecting the belting. (9, p.12)

Working conditions must be constantly observed by the company, and if doubt exists, as to whether you deem your equipment safe enough for your employees welfare, call a qualified safety engineer to advise you as to whether or not your equipment satisfies current safety regulations and requirements of any federal, state, municipal or other duly constituted regulatory agency to whom you might be responsible.

It is also the responsibility of the company to properly train your personnel in the correct use of this equipment. Keep in mind that what might be considered an open and obvious danger to the most experienced plant operator could be completely ignored and overlooked by an inexperienced or less perceptive employee.

## **5 WORKING METHODS AND RESULTS**

In this chapter, an automatic idler production line is designed and introduced to enhance the productivity of idlers. Common problems of belt conveyor are listed and solved by posing some conceptual design which is based on reliable research. Another conceptual design put forward is manufacturing a belt conveyor used for extreme cold weather.

### **5.1 Manufacturing idlers in large scale**

Idler is the main part of a belt conveyor and it's easily broken, the market demand is very great. At present, there are nearly a thousand roller manufacturers in China. The quality of technical equipments and products vary, only twenty or thirty companies can have quality and scale advantages. According to the data, high-quality and service life idlers account for less than 20% in market share, which means that as an important link of conveyor chain it has a huge development space.

To improve the competitiveness of products, to meet the needs of market development, a fully automated idler production line is needed to be invested in at Chaohu Machinery Manufacturing Co., Ltd. The line should include bearing punch line, bearing seat automatic processing machines, axis machining center, pipe cutting line, assembly and test production line, spray drying production line. The idler production process is shown in Figure 18.

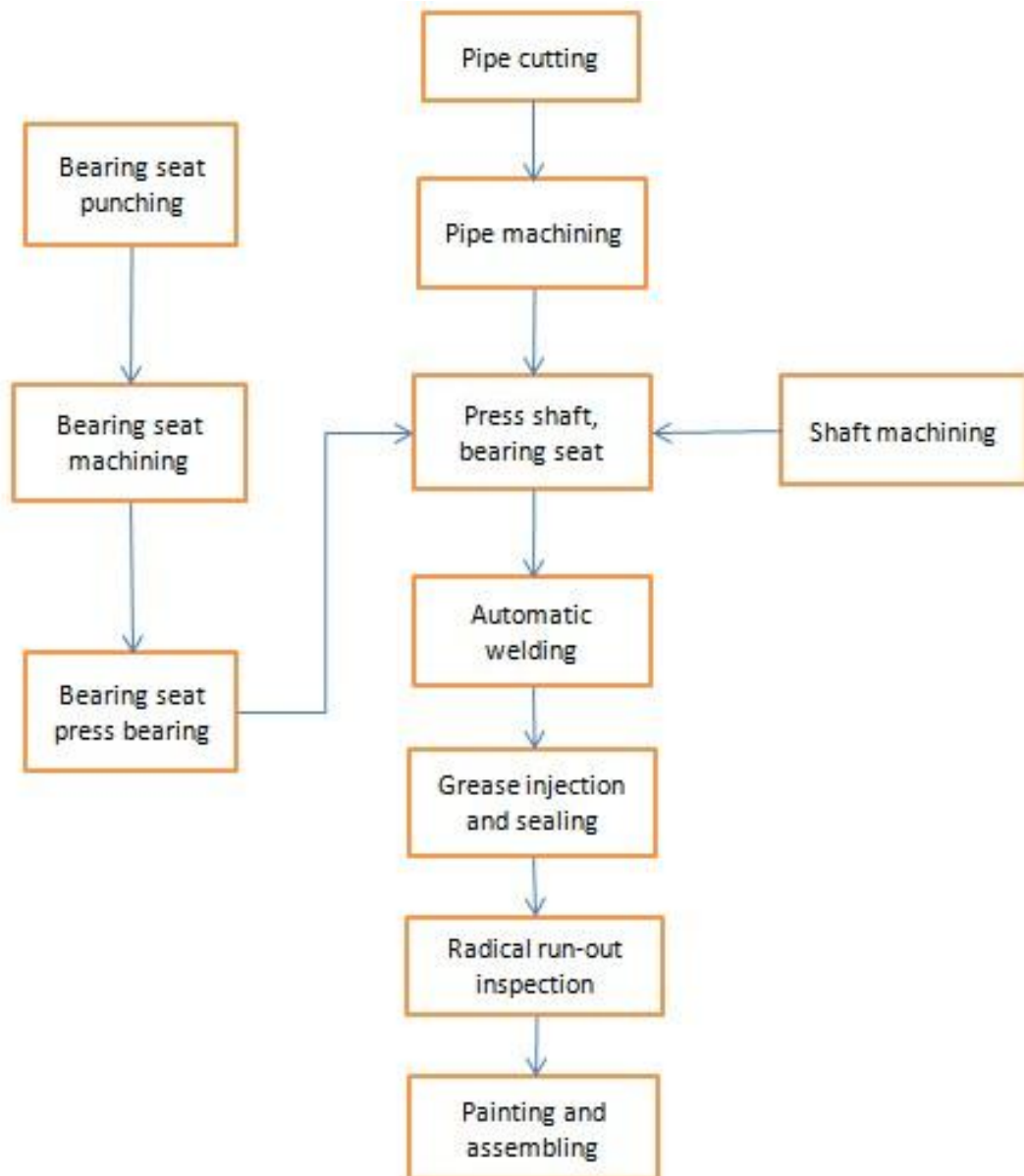

Fig18. Idler production line

### 1 Bearing seat punching line

The production line is mainly composed of uncoiler, straightener/feeder, manipulator, punch and unloader and so on. Cold-strip steel passes uncoiler, straightener to uncoil and feed automatically followed by the punching process in six steps in turn to finish stamping of bearing seat. The change of tooling die can be achieved through mold changing systems, which is convenient and reliable. In control, gang control is carried out in punching equipment and manipulator, with the function of setting parameters,

optimizing and editing, saving, fault diagnosing and alarming.

## 2 Automatic bearing seat processing machines (including press bearing)

Stamped bearing seat on the spinning staging is transferred to special lathe by a manipulator, and the lathe machining bearing seat's ex-circle and chamfer automatically, the bearing seat is transferred to bearing press by the conveyor to press bearing automatically, and finally sent to unloading platform.

## 3 Axis machining center

Multi-station CNC machining center can be divided into four parts in accordance with the machining process: (1) The length of about 6m, diameters of  $\varnothing 20$ ,  $\varnothing 25$ ,  $\varnothing 30$ ,  $\varnothing 35$ ,  $\varnothing 40$ mm of cold drawn round steel can be by blanked by dimensions, cutting length of 330 ~ 2548mm, length error in 0.2mm. (2) The work pieces which are used to chamfer shaft and drill the center hole are fed into the lathe automatically by a manipulator, to complete the processing of chamfer at both ends of the shaft and drill the center hole after being located and clamped. (3) Processing two circlip grooves in the shaft at both ends. (4) Through slot (or solid slot) are milled at both ends of the shaft at the same time, slot error should be controlled to 0.1mm or less.

The processing center can achieve automatic feeding and discharging, scaling-off, debugging, easy to change clamp, equipment has reliable operation, as well as with the function of setting parameters, optimizing, modifying, saving, fault diagnosing, alarming, etc.

## 4 Pipe cutting lines

Roller tubes with the diameters of  $\varnothing 89$ ,  $\varnothing 108$ ,  $\varnothing 133$ ,  $\varnothing 159$ ,  $\varnothing 194$ mm and with a wall thickness of 3.2 ~ 5.0mm can be achieved to complete automatic feeding, cutting off, automatic processing of both ends of the surface and the internal hole.

## 5 Assembling and inspecting line

This production line consists of 5 parts: (1) Cleaning device on the pipe tube surface which is mainly used for removing rust of the tube surface. (2) Pipe receiving platform is used for receiving, storing the pipes transferred from the pipe machining lathe, and transporting to a welding device. In the process of conveying pipes, compressed air is used to purge the inside of the pipes. (3) The welding device includes shaft inserting, bearing seat pressing and fitting, and bearing seat welding. (4) Storage platform for cooling the idlers being welded and conveying idlers to the assembly and inspecting lines. (5) The roller assembly and inspecting includes grease injection, pressuring seals, installing circlip, and inspecting circular run-out. Lithium lubricating grease is used as a lubricant, which is suitable in the environment of high temperature. (More than 170°C)

The process of pipes accepting, welding and assembling and inspecting, etc a series of procedures rely on robots, manipulators to be completed. Special injection equipment is used to grease seal; the qualified pieces are distinguished from the failed ones when circular run-out is tested.

## 6 Spraying and drying production line

Idlers are transferred to the drying room by a chain drive after electrostatic spraying in the spraying room. Idlers are dried because of the circulating air in the drying room. The output of the finished products is achieved in the final stage. (10)

## **5.2 Solutions to current existing problems of belt conveyor**

During the running process of belt conveyor, many problems can appear because of the wrong selection of material or irregular assembling methods. Conveyor belt is run-off center and spillage are two common problems met by belt conveyor users. The two phenomena are analyzed and solved in this chapter.

### 5.2.1 Conveyor belts run-off center

A conveyor belt that run-off center is a common and potentially costly problem in aggregate facilities. Edge wear and some other damage the belt itself can cause running off-track, damage to other components of the system could also be possible, like idlers and pulleys, and possibly spillage of materials being moved through the plant.

Belt tracking is used to ensure that a conveyor belt does not run off the center which is a complex process of adjusting idlers, pulleys and loading conditions. Whether training an existing conveyor belt that has gone off track or a new one that has just been installed, a check list can be read first:

- Are the head and tail pulley shafts parallel to each other?
- Are all belt idlers correctly bolted down and perpendicular to the frame to which they are bolted?
- Are training idlers installed properly and pointed in the correct direction?
- Are all drive components-the speed reducer, the V-belt drive, and the electric motor in a good working condition?
- Does the gravity take-up have the proper amount of weight?
- Have the belt skirting and wipers been properly adjusted?
- Are all conveyor pulleys and belt idlers free form material buildup?
- Are lagging materials on conveyor pulleys worn or damaged?
- Has all foreign material been removed from around the conveyor?

If “Yes” can be answered to all these questions and the conveyor belt still does not track properly, then the conveyor’s structure should be checked if it is straight, and a laser alignment system is the best way to determine the straightness of the structure. (15)

When working on the system, start at the head pulley and work toward the tail pulley on the return side of the belt (bottom side). Locate the maximum point of off-tracking and back up to the fourth, fifth or sixth idler before that point to begin making adjustments.

A conveyor belt will always move towards the part of an idler or pulley it touches first and this should be always kept in mind. Hence, any idler or pulley not running parallel

with its counterparts serves as a de-training device. Small adjustments are made to one idler at a time and improvement is checked before making another adjustment. Multiple idler shifts or dramatic adjustments can compound the tracking problem. The direction of the belt's travel is always followed when making corrective shifts. After adjustments are made, the belt is jogged for several revolutions while it is checked at head, drive, take-up and tail and along the carry and return runs for smooth passage. (16)

Normally off-track problems will be corrected using training devices or making a series of adjustments as described above. However, if these measures do not correct problems, also look for off-center loading of the belt, bent or damaged structures or defective conveyor belting. If the problem is unable to be identified and corrected, it might be necessary to consult a qualified engineer or specialist.

Correct training of a conveyor system prevents costly wear and tear and other more serious damage to the system components. The adjustments should also contribute to making the workplace safer by preventing materials spillage. The relatively short time it takes to train a conveyor may save serious downtime.

### **5.2.2 Spillage of conveyor belt**

Material spillage on bulk conveyors accounts for plant inefficiencies, increased overhead and occupational hazards. Conveyor belt spillage accounts for increased operating costs nowadays. There are several types of spillage.

Carryback on the conveyor belt - Usually in the form of very fine particles, flakes produced from these fine particles, or a slurry or paste consisting of these very fine particles. It is easily identified as piles of material under bend pulleys and return idlers. (14, p.2)

Skirt leakage. Leakage at the skirt seal - When handling granular material the leakage

from the skirt section tends to be particulate matter of one to five millimeters in diameter, which is sized by the characteristic gap between the rubber seal and the sag in the belt between idlers. This material will typically accumulate in the immediate area around the skirted portion of the conveyor. If the material being conveyed has a large percentage of fines, this material can also leak from the skirted area. This material is usually airborne and deposits itself as a layer of dust over a large area. In extreme cases it may accumulate in piles at the transfer point. (14, p.2)

Spillage at loading. This is typically large lumps of material and is found scattered in an area around the exit of the transfer point's chute work. It also is commonly found on the inside return strand of the conveyor and it may accumulate at the tail pulley in the form of build-up on the pulley. In extreme cases this build-up can stick to the belt and be carried to the head pulley. (14, p.2)

Spillage at discharge. Spillage at the head section can be caused by an overloaded conveyor. As the belt flattens out to go over the head pulley the load spills to the side or it can be the placement of the dust curtain or the restricted entrance caused by the design of the chute work. The material spilled at this location is similar to that spilled at the exit of the transfer point. It too can be distributed over a long section of the conveyor. (14, p.2)

Belt mistracking. Spillage from mistracking can be the most catastrophic of all types of spillage. In a matter of seconds tons of material can be dumped, belts rolled over and transfer points destroyed. The causes of mistracking are numerous. A well-tracked or trained belt is the first prerequisite to a clean operation. Misalignment switches are a must and can be justified by the elimination of just one major mistracking incident. (14, p.3)

The root in minimizing spillage begins at the procurement phase. Correct conveyor design especially for the load and transfer zones is the key. Belt skirting arrangements should include a commercially available system which allows for simple



interchangeability and adjustment of the sealing membrane. The skirting seal should only lightly skim the top of the conveyor belt while excessive contact will prematurely wear the seal membrane and belt coating. Belt tracking issues and excess drag on the power train may also be a byproduct. The use of 'homemade skirts', unless designed correctly, can be difficult to adjust and provide uneven belt contact. An easily adjustable skirt will allow the tradesperson to proactively 'fine tune' the sealing system and be more likely undertaken as a regular maintenance procedure. Transition and load zones should be designed with sufficient roller support or impact beds beneath the belt to prevent 'belt-sag'. Belt deflection would only exacerbate spillage between the skirts and introduce material entrapment points.

Correct alignment of transfer zones between adjoined conveyors or process plant is recommended. It is important for the material to be loaded in a controlled flow centrally onto the conveyor belt and evenly between the skirting boards. Misalignment will allow refuse to spill over skirting seals, introduce tracking problems and damage to the pulleys and components. Load zones should consider the 'drop' distance from the pre feeder conveyor onto the receiving belt. To protect components and minimize airborne dust this spacing should be designed to a minimum. For material fines or dusty product, such as gypsum or chemical compounds, it can be difficult to capture 100% of airborne particles. One option to reduce this risk is to fully encapsulate the belt and implement an integral extraction system, in particularly for indoor facilities where occupational hazards are a possibility.

Transfer zones and belt-cleaner tailings can be problematic areas for material spills. If the spillage is contained to an isolated area then a supplementary 'scavenger conveyor' can be considered. A range of scavenger, tailings conveyors, drag-chain-conveyors or vibratory conveyors mounted beneath the material source may prove the solution to collect and return the spillage to the transfer chute.

### 5.3 Designing of a belt conveyor for extreme cold weather

As is mentioned before, a commonly used belt conveyor is just suitable for the temperature from  $-10^{\circ}$  to  $+40^{\circ}$ . However, if more profit is pursued by a company, it is necessary to exploit new market. The plan of designing a kind of belt conveyor that can be used in extreme cold weather is raised by the writer of this thesis.

Special care is required in designing belt conveyors for use in extreme cold climates. For example, temperatures in Finland can vary from  $-40^{\circ}\text{C}$  in winter to  $+25^{\circ}\text{C}$  in summer. During the winter, snow load, blowing snow and ice build-up are problems that are encountered. The product being handled can have ice particles frozen to it and can also contain loose snow. In the meantime, under such extreme low temperatures, steel becomes brittle and susceptible to damage from impacts. In warmer climates, the design limits can be pushed and short, steep, small, high-speed conveyors can be used. In extreme cold climates, simultaneously pushing all design limits is a recipe for disasters, it's best to be conservative in the design. The following factors need to be taken into consideration when the belt conveyor is designed.

1) Snow: It can be expected that a product stored in open storage piles will be covered with snow for most of the year. The problem can be particularly bad under heavy snowfall conditions where the product is left outside to be covered by multiple snow layers. Unless the snow is scraped off, conveyors should be sized to handle the anticipated amounts of loose snow being reclaimed with the product.

Also, it can be expected that frozen lumps come off the pile. If there is no scalping screen or lump breaker ahead of the conveyor, the chutes and skirt boards should be designed to handle the largest frozen lump. The load on the belt should be kept lower than normal to increase belt-to-product contact and to provide more room for carrying lumps; and the speed should be kept fairly slow. This will result in a wider belt than normally.

2) Belt transfers and angles: In order to give the frozen and slippery product time to reaccelerate, special care is required in transitioning from one conveyor to another.

To ease the transfer of material from one conveyor to another, the conveyor's slope should be limited in the loading zone to 6°-7°.

The maximum conveyor slope is limited to 12° and across-the-line starting is avoided in order to prevent the material from sliding back when restarting a loaded belt. Additionally, maintenance can be done in warm electrical rooms as opposed to maintaining a fluid coupling outside in the cold.

If conveyor slopes greater than 12° can't be avoided, the use of grooved belts can be considered. They are suitable up to 15°. Above 15°, use belts with positive, vulcanized multi-cleats.

- 3) Covers: Conveyors should be covered to prevent the material blowing off the belt. However, it is recommended that the entire conveyor should be carried inside an enclosed gallery with the transfers inside enclosed towers. At extreme cold temperatures, even a slight breeze can cause frostbite to persons in just a few seconds. If working conditions are poor, the equipment may not be properly maintained.

At the same time, the bottom of the gallery underneath the belt needs to be kept open to permit snow and dust to fall free from the return belt. The build-up of snow and dust should be avoided inside the gallery; it is hard to remove, as well as it can result in a serious structural overload condition. The amount of snow and dust falling off return idlers can be substantial, so lots of space under conveyors should be provided for clean-up access.

- 4) Personnel access: Access on frozen, snow covered surfaces can be treacherous. Stairs are recommended and no ladders should be used wherever possible. Safety-grip grating can be used on walkways and platforms to ensure safety.
- 5) Conveyor components: Extraordinary expansion and contraction can be expected

within extreme temperature ranges and must be accommodated in the design of conveyors and structures. The conveyor and structures must have a sufficient quantity of expansion joints, properly placed to accommodate this expansion and contraction.

Belting designed for extreme low temperatures is used, which retains their flexibility without cracking.

Use lubricants designed for extreme temperature variations. Under extreme cold temperatures, the viscosity should not increase to the point that grease and oils solidify but remain fluid. Conversely at extreme warm temperatures, the lubricants which thin-out to the point where they are no longer lubricating cannot be used. Drive pulleys with large diameters are used and vulcanized diamond-shaped lagging. The use of snub pulleys is recommended. High alloy steel pulley shafts are avoided. It's best to stay with large diameter, low carbon shafts. Thick pulley end discs which resist flexing should be avoided to use.

- 6) Belt cleaners: Belt brush cleaners are not recommended since they will be immediately filled up with snow and dust and are ineffective. Two sets of carbide-tipped belt scrapers are recommended for scraping frozen snow and dusting off the belt. There will be a lot of snow dust coming off the scrapers, so lots of room underneath the scrapers inside the head chute is an urge.

Snow and dust will stick to almost any surface; therefore, large chutes with steep angles and large radius corners between chute plates are more suitable.

- 7) Dust control: Airborne dust problem is more serious in winter. Snow crystals will be loosened from the product and sucked into the dust pick-ups. Bag houses can quickly become clogged with packed snow. So, it is recommended that high efficiency cyclones, which are less prone to plugging, are to be used.

It is realized that not all of the above recommendations can always be accommodated, particularly those to do with conveyor geometry. Also, budget concerns can exert pressure on design features such as using open galleries or minimizing length, which has the disadvantage of increasing slope, or running conveyors faster to minimize the size.

It is found that many existing installations are not constructed as what has been described above and yet work satisfactorily. Every installation is unique and all conditions must be considered. However, providing that space and budget available, and the above guidelines are followed, an effective, problem-free cold weather conveying system can be constructed.

## 6 CONCLUSIONS

As a conclusion of this final year project, it was discovered that there are some technical defects in the manufacturing of belt conveyors in the Chaohu Machinery Manufacturing Co., Ltd. The selection of the conveyor belt, manufacturing of other components like idlers, pulleys are meaningful when producing a high-quality belt conveyor. Many commonly occurred problems could be avoided by proper installation. In order to enhance the productivity of manufacturing idlers, which means producing idlers in large scale, an automatic production line can be built, which may increase the investment capital, but we can find that workers' salaries which belong to variable costs can be reduced largely. It is believed that the benefits are outweighing the costs, especially when the company gets a big order. However, the production line is not that perfect, further research and systematic survey must be done to perfect it.

As for building a belt conveyor that is suitable for extreme cold weather, basic manufacturing principle is similar to the common one, the change is in the choosing of material. If it can be manufactured successfully, sales districts can be enlarged to cold cities Harbin in China or even foreign countries, like Canada, Finland and so on. Increase of sale volume means increase in profit.

The theoretical part of this thesis was collected from books, as well as from internet sources. The most used sources were from the interviews of workers at the production line and the manager of the company. What they gave to me was really practical and helpful.

## REFERENCES

### Published documents

- 1 Arkansas, Jonesboro. 2007. The ABC Conveyor Book. Hytrol Conveyor Co, Inc. Publisher unknown.
- 2 Zuo, Qing. 2008. Belt conveyor design sample. Wuhan: Wuhan University. Department of Engineering. A thesis.
- 3 Jiang, Guilan. 2008. Belt conveyor. China: Guangming Publications.
- 4 Han, Feng. 2010. Research of Motorized Pulley. China: Publisher unknown.
- 5 Writer unknown. 2000. A guide to conveyor safety. Work Cover. China: Xinwen Publications.
- 6 Wang, Hongjuan. 2007. Conveyor belting. China: Guangming Publications.
- 7 Zhao, Xiong 2009. Technology of roller manufacturing. Science and Innovation. 31(8).
- 8 Li, Xing. 2008. Energy technology and management. China: Xinglang Publications.
- 9 Installation and Maintenance of belt conveyor. A brochure. Place of publishing or publisher unknown.
- 10 2009. Continental belt conveyor systems. IPS group, Inc. New York: Dover Publication

- 11 Measurement and control of spillage and leakage at conveyor transfer points.  
Place of publishing or publisher unknown.

### **Network documents**

- 12 Cleaner.  
[http://www.google.com/images?hl=en&source=imghp&biw=519&bih=508&q=%E5%BC%B9%E7%B0%A7%E6%B8%85%E6%89%AB%E5%99%A8&gbv=2&aq=f&aqi=&aql=&oq=&gs\\_rfai=](http://www.google.com/images?hl=en&source=imghp&biw=519&bih=508&q=%E5%BC%B9%E7%B0%A7%E6%B8%85%E6%89%AB%E5%99%A8&gbv=2&aq=f&aqi=&aql=&oq=&gs_rfai=)  
Search date: 10.11.2010.
- 13 Idler. <http://qkzz.net/article/2e4171ae-b742-4249-a581-e98989623836.htm> Search date: 12.11.2010.
- 14 Introduction to belt conveyor. <http://baike.baidu.com/view/265504.htm> Search date: 15.11.2010.

### **Phone conversation and interview**

- 15 Gu, Jianguo, CEO, Ma Steel. Phone conversation. 20.6.2009.
- 16 Chen, Haifan, CEO, Chaohu Machinery Manufacturing Co, Ltd. Interview. 1.7.2009.



## APPENDICES

### Technical data of belt conveyor

Belt width (mm)	Conveying distance (m)		Power(KW)	Conveying speed(m/s)	Conveying capacity
400	≤12/2.2	12-2-/2.2-4	20-25/3.5-7.5	1.25-2.0	30-60
500	≤12/3	12-2-/3-5.5	30-30/5.5-7.5	1.25-2.0	40-80
650	≤12/4	12-20/4-5.5	20-30/5.5-11	1.25-2.0	80-120
800	≤6/4	10-15/4-5.5	15-30/5.5-15	1.25-2.0	120-200
1000	≤10/5.5	10-20/5.5-11	20-40/11-22	1.25-2.0	200-320
1200	≤10/7.5	10-20/7.5-15	20-40/15-30	1.25-2.0	320-480

### All kinds of conveying equipment



Heat resistant conveyor

Main features: working in the temperature of 300°C; enclosed conveyor to reduce dust pollution; big conveyor capacity, good effect of heat insulation; easy to install or move position.



Mobile belt conveyor

It is a kind of high working efficiency, good motility constant conveying equipment. Mainly used in the occasion of changeable loading and unloading places, like harbor, dock, and station.



Steeply inclined belt conveyor

It is a kind of conveying equipment for transferring bulk material; the used conveyor belt is with wavy flange and diaphragm plate. The working temperature is between  $0^{\circ}$ - $90^{\circ}$ . It has the features of high inclination, big output efficiency, non spillage and high flexibility of arranging.



### Chain conveyor

It has totally closed enclosure, good seal, energy saving, big conveyor capacity. It has superiority due to its working principle: the material has the feature of internal friction and lateral compression, the movement of conveyor chain increase the internal pressure of material and internal friction of particles, when the internal friction of material is bigger than the external friction between material and slot wall, the material will move along with the chain like water.

## Lathes, punching machine and milling machine



CT系列普通车床

CT-series lathe

Features: turning the internal and external cylindrical surface, end face and other surfaces of revolution; drilling, reaming, boring and making oil groove; machining accuracy is IT16, machining surface roughness is  $R1.6\mu\text{m}$ ; good stiffness, no vibration when cutting brutally; overload safety device is set in carriage.



Precise table model punch machine  
 Specified operating pressure (KN): 10  
 Maximum shut height (mm): 140

Larynx depth (mm): 250  
Work platform size (mm): 270\*290  
Motor power (W): 370  
Recess size (mm):  $\varnothing 16 \times 40$



#### Radial universal milling machine

Big flexibility, cutter head is installed in the rocker, which can turn around in portrait and landscape vertical plane, the rocker arm can rotate  $360^\circ$ . cutter header has high rotation speed.

# Safety Labels for Conveying Equipment



THESE CEMA SAFETY LABELS CAN HELP MAKE YOUR CONVEYING EQUIPMENT OPERATIONS SAFER

<p><b>WARNING</b> Exposed moving parts can cause severe injury <b>LOCK OUT POWER</b> before removing guard</p> <p>CV-983001 or CV-983001</p>	<p><b>CAUTION</b> Trip hazard Be Alert Watch your step</p> <p>CV-983008</p>	<p><b>WARNING</b> Servicing while pressurized can cause severe injury <b>LOCK OUT SOURCE</b> and <b>RELIEVE PRESSURE</b> before servicing</p> <p>CV-983018</p>	<p><b>WARNING</b> Walking or standing on conveyor covers or grating can cause severe injury <b>STAY OFF</b></p> <p>CV-983028</p>		
<p><b>WARNING</b> Equipment starts automatically can cause severe injury <b>KEEP AWAY</b></p> <p>CV-983003</p>	<p><b>WARNING</b> Servicing moving or rotating equipment can cause severe injury <b>LOCK OUT POWER</b> before servicing</p> <p>CV-983009</p>	<p><b>DANGER</b> Moving parts will cause severe injury <b>KEEP AWAY</b></p> <p>CV-983017</p>	<p><b>WARNING</b> Operating conveyor without overhead guard can cause severe injury <b>KEEP GUARD IN PLACE</b></p> <p>CV-983027</p>		
<p><b>DANGER</b> Hazardous voltage will cause severe injury or death <b>LOCK OUT POWER</b> before servicing</p> <p>CV-983005</p>	<p><b>WARNING</b> Exposed conveyors and moving parts can cause severe injury <b>LOCK OUT POWER</b> before removing cover or servicing</p> <p>CV-983010</p>	<p><b>CAUTION</b> HOT SURFACE Contact with skin may cause burns <b>DO NOT TOUCH</b></p> <p>CV-983016</p>	<p><b>CAUTION</b> Access guarding system is normally active Follow for properly locked, tagged, and secured equipment. Do not touch, climb, or tamper with equipment.</p> <p>CV-983019</p>		
<p><b>DANGER</b> Climbing, sitting, walking or riding on conveyor at any time will cause severe injury or death <b>STAY OFF</b></p> <p>CV-983004</p>	<p><b>WARNING</b> Exposed screw and moving parts can cause severe injury <b>LOCK OUT POWER</b> before removing cover or servicing</p> <p>CV-983011 or CV-983011</p>	<p><b>WARNING</b> Exposed moving parts can cause severe injury <b>LOCK OUT POWER</b> before servicing</p> <p>CV-983014</p>	<p><b>CAUTION</b> Access guarding system is normally active Follow for properly locked, tagged, and secured equipment. Do not touch, climb, or tamper with equipment.</p> <p>CV-983026</p>		
<p><b>WARNING</b> Moving equipment can cause severe injury <b>KEEP AWAY</b></p> <p>CV-983108</p>	<p><b>WARNING</b> Exposed moving parts can cause severe injury <b>LOCK OUT POWER</b> before servicing</p> <p>CV-983012</p>	<p><b>WARNING</b> Servicing while pressurized can cause severe injury <b>LOCK OUT SOURCE</b> and <b>RELIEVE PRESSURE</b> before servicing</p> <p>CV-983022</p>	<p><b>CAUTION</b> Access guarding system is normally active Follow for properly locked, tagged, and secured equipment. Do not touch, climb, or tamper with equipment.</p> <p>CV-983025</p>		
<p><b>CAUTION</b> Do not enter Hazardous Area Authorized personnel only</p> <p>CV-983008</p>	<p><b>CAUTION</b> Hazardous noise level Ear protection required in this area</p> <p>CV-983015</p>	<p><b>WARNING</b> Rotating shaft can cause severe injury Keep hair and loose clothing away</p> <p>CV-983023</p>	<p><b>CAUTION</b> Access guarding system is normally active Follow for properly locked, tagged, and secured equipment. Do not touch, climb, or tamper with equipment.</p> <p>CV-983024</p>		
<p><b>CAUTION</b> Low Clearance Be Alert</p> <p>CV-983007</p>	<p><b>CAUTION</b> Hazardous environment Respiratory protection required Authorized personnel only</p> <p>CV-983013</p>	<p><b>WARNING</b> Guard Removed Risk of severe injury <b>DO NOT OPERATE</b> Without guard</p> <p>CV-983028</p>			
<p><b>WARNING</b> Exposed conveyors and moving parts can cause severe injury <b>LOCK OUT POWER</b> before removing</p> <p>CV-983010</p>	<p><b>WARNING</b> Exposed screw and moving parts can cause severe injury <b>LOCK OUT POWER</b> before removing cover or servicing</p> <p>CV-983011</p>	<p><b>WARNING</b> Exposed buckets and moving parts can cause severe injury <b>LOCK OUT POWER</b> before removing cover or servicing</p> <p>CV-983012</p>	<p><b>DANGER</b> Hazardous Condition Entry will result in severe injury or death <b>LOCK OUT POWER</b> AND <b>BLOCK NOISE</b> before servicing</p> <p>CV-983016</p>	<p><b>WARNING</b> Exposed moving parts can cause severe injury <b>LOCK OUT POWER</b> before removing guard</p> <p>CV-983020</p>	<p><b>CAUTION</b> Risk of Electrical Shock More than one disconnect switch may be required to de-energize the equipment before servicing</p> <p>CV-983024</p>