



Expertise  
and insight  
for the future

Amul Ranabhat

# Wireless power charging

Metropolia University of Applied Sciences

Bachelor of Engineering

Electrical Engineering

Bachelor's Thesis

15 November 2019

Author Title	Amul Ranabhat Wireless Power Charging
Number of Pages Date	26 pages 21 November 2019
Degree	Bachelor of Engineering
Degree Programme	Electronics Engineering
Professional Major	Matti Fischer
Instructors	Matti Fischer; Principal Lecturer
<p>The purpose of this project is to innovate or research a contactless power transfer. This project also helps to understand the capability of students that he/she can use the tools and make somethings useful. This technology is also found to be suitable in the every electronics charging sector or teachers can use it for teaching purposes also. WPT is nowadays key of interest. Its seems like an era has been shifted from wired to wireless</p> <p>The main goal of this project is use to study the physics behind wireless electricity transfer technology. Here the Alternating current (AC) is Transferred wirelessly through the contactless power transfer and hence converted into Direct current (DC) where we stabilized the voltage using a voltage regulator. The same project is done on the software using multi-physics simulation software.</p> <p>As a result, the constant 5 volts from the simulator was obtained.</p>	
Keywords	Wireless Power Transfer (WPT) Alternating current (AC) Direct current (DC) Contactless Power Transfer (CPT)

## Contents

List of Figures

List of Tables

1	Introduction	1
2	Applications and Range	2
3	Theoretical Background about wireless power transfer	5
3.1	History of Wireless Power Transfer	5
3.2	Transformer	6
3.2.1	Step-up transformer:	6
3.2.2	Step-down Transformer	7
3.3	Ideal Transformer	8
3.4	Transformer Efficiency	10
3.4.1	Eddy Current	12
3.4.2	Hysteresis	12
3.4.3	$I^2R$ Loss	12
3.4.4	Power Factor	13
4	Methods and Materials	13
4.1	Materials	13
4.1.1	Ferrite core	13
4.1.2	Diode	14
4.1.3	Capacitor	15
4.1.4	Voltage Regulator	16
4.2	Circuit Design and Analysis	18
5	TESTS AND RESULTS	19
5.1	Measurement Setup	19
6	Conclusion	26
7	References	27

## List of Tables

Table 1. Wireless power technologies range and its applications [1].....	3
Table 2. Different voltage on different frequencies .....	21
Table 3. The voltage at the secondary coil and load resistor with varying frequency...	23
Table 4. Voltage after rectification and at load with varying frequency .....	24

## List of Figures

Figure 1. General Function of the transformer. [2].....	4
Figure 2. Tesla Performing Tests. [4].....	5
Figure 3. Step-up transformer .....	6
Figure 4. Step-down transformer .....	7
Figure 5. Flux being generated in ferromagnetic core [5] .....	8
Figure 6. Ideal transformer [6].....	8
Figure 7. Output power versus efficiency. [8] .....	10
Figure 8. Positive half-cycle and negative half-cycle. [11].....	15
Figure 9. Two Capacitor 47 $\mu$ f and 220 $\mu$ f respectively used in the lab. ....	16
Figure 10. Voltage Regulator Pinout of LM78L05 and circuit connection [12].....	17
Figure 11. LM78L05 Datasheet [12].....	17
Figure 12. Circuit diagram of wireless power transfer using NI Multisim.....	18
Figure 13. Stimulation reading on Oscilloscope. ....	19
Figure 14. The relation between the varying frequency and the output Power .....	21
Figure 15. The relation between the output voltage and frequency .....	23
Figure 16. The relation between Voltages after rectification and voltages at load .....	25

## 1 Introduction

The purpose of this project is to generate stable 5 volt DC at the load. For this project, the AC source is given which is transferred wirelessly using a transformer. After that, it is converted into DC using a bridge rectifier. As the rectifier has a wide range of use but it is mainly used for converting AC to DC. After rectification, the required DC voltage is generated.

Wireless Power Transfer is defined as the transmission of electrical energy without the use of wires or any other physical link. In a wireless power transfer, power is extracted from the field and supplies it to load. This technology can eliminate the use of any physical link like wires, battery hence increasing the mobility, convenience, and safety of an electronic device for all users. It can be very useful to power electrical devices where wire connection is inconvenient, hazardous, or are not possible.

Wireless power transfer (WPT) is a topic of discussion. Although wireless power transfer has been known for more than a century nowadays the industry has been rapidly increasing. We can say the whole of today's era is about wireless. The mobile phone which we use in our daily life is a very huge example of wireless technology. This technology is making our life smoothly. Wireless power transfer (WPT) helps to supply power through an air gap, without the need of any current-carrying wires. It can provide power from an AC source to any compatible batteries or devices without the use of any physical link or wires. It can be used to recharge mobile phones, tablets, drones, cars, etc. However, it can be even possible to wirelessly transmit power gathered by solar panel arrays in the space.

## 2 Applications and Range

Wireless power techniques are categorized into two types. They are near-field and far-field. In the near field, power is transferred between short distances using inductive coupling between the coils of wire, or power is transfer through a magnetic field or capacitive coupling between the metal electrodes, or power is transferred through electric fields. Inductive coupling is most widely used wireless technology like charging handheld devices like mobile phones, electric toothbrushes, RFID tags, induction cooking, an artificial pacemaker or electric vehicles.

In far-field or radioactive techniques, power is transferred by the beam of electromagnetic radiation, like microwaves or laser beams. These methods can transport energy to longer distances. These techniques can be applied to solar power satellites and wireless powered drone aircraft.

Table 1 describes the technology that is used for the near and far-field. The table describes more about the various wireless technology that comes under short-range and long-range and working frequency range of technology as well as the current application and future application. The technologies that use inductive coupling, resonant inductive coupling, capacitive coupling, and magneto dynamic coupling fall under the near-field or short-range whereas microwaves and light waves are far-field or long-range.

Table 1. Wireless power technologies range and its applications [1]

Different Technology	Ranges	working Frequency	Energy Transferred	Applications
Inductive coupling	Short range	Hz – MHz	Magnetic fields	It is used in electric tooth brush, razor, battery, induction kitchen and industrial heaters.
Resonant inductive coupling	Mid-range	kHz – GHz	Magnetic fields	It is used for charging portable devices (Qi), biomedical implants, electric vehicles, powering buses, trains, RFID, smartcards.
Capacitive coupling	Short range	kHz – MHz	Electric fields	It is used for charging portable devices, power routing in large-scale integrated circuits, Smartcards, biomedical implants.
Magnetodynamic coupling	Short range	Hz	Magnetic fields	It is used for charging electric vehicles, biomedical implants.
Microwaves radiation	Long range	GHz	Microwaves	It can be used for powering solar power satellite, drone, aircraft, charging wireless devices.
Optical radiation	Long range	$\geq$ THz	Light or infrared or uv rays.	It can be used for charging portable devices, powering drone aircraft, powering space elevator climbers.

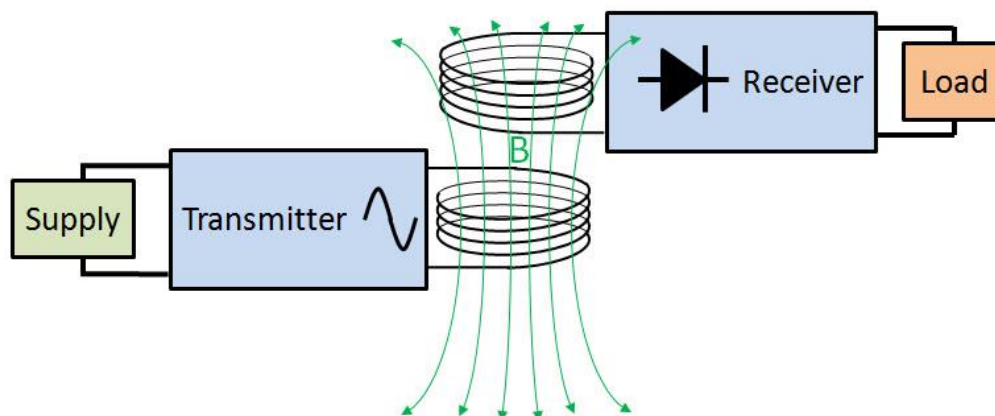

Figure 1. General Function of transformer. [2]

Figure 1 explains the general function of the transformer. The wireless system consists of a transmitter that is connected to the power supply on one end and another end is connected to the primary coil of the transformer. Input power is converted into an electromagnetic field by the coil of wires. Similar coils on the receiver convert the electromagnetic field generated by the transmitter into an electric current which is used by the load. Instead of wire to generate a magnetic field, we can use the metal plate for generating an electric field, antenna for radiating radio waves or laser for generating light.

### 3 Theoretical Background of wireless power transfer

#### 3.1 History of Wireless Power Transfer

Wireless Power transfer is not a new topic it has been known for more than a century only now has the WPT industry started its rapid growth. The concept of transferring power without wires, however, has been around since the late 1890s. Nikola Tesla was able to light the electric bulbs wirelessly at his Colorado Springs Lab using resonant inductive coupling. Tesla`s main ideas were to use our planet as a conductor to transmit power to any point on Earth.

He spends a great deal of his time and fortune from the 1890s to 1906 on developing wireless power transfer. At the time Tesla was formulating his ideas, where there was no feasible way to wirelessly transmit communication signals over long distances. [3]



A multiple exposure picture of Tesla sitting next to his "magnifying transmitter" generating millions of volts. The 7-metre (23 ft) long arcs were not part of the normal operation, but only produced for effect by rapidly cycling the power switch. [145]

Figure 2. Tesla Performing Tests. [4]

## 3.2 Transformer

A Transformer is the most common and practical device used in Alternating Current (AC) found in the electrical system that links the circuits which operate at different voltages. Transformers are used when the conversion of voltage to another level is needed. It helps to convert the voltage and current based on the requirement of load or any other electrical devices. The transformer works on the principle of mutual induction of two coils which is also known as Faraday Laws of electromagnetic induction. When an alternating electric source is supplied in one coil there will be EMF induced in the second coil. If the circuit is closed on the secondary side of the transformer current will flow through it. This is how the transformer works. Based on the function, the transformer are divided into two categories. They are step-up transformers and step down transformers.

### 3.2.1 Step-up transformer:

It is a type of transformer which is used for increasing the output voltage. In these types of the transformer, the number of turns in the secondary coil is more than the number of turns in the primary coil. These types of transformer are used to raise the voltage to a higher level. In figure 3. We can see the step-up transformer to raise the voltage. Here, the number of turns in the primary coil is 3000 and the AC voltage of 25 volts is supplied and on the secondary side, we can see the number of turns is 6000 which is higher and the voltage is also higher.

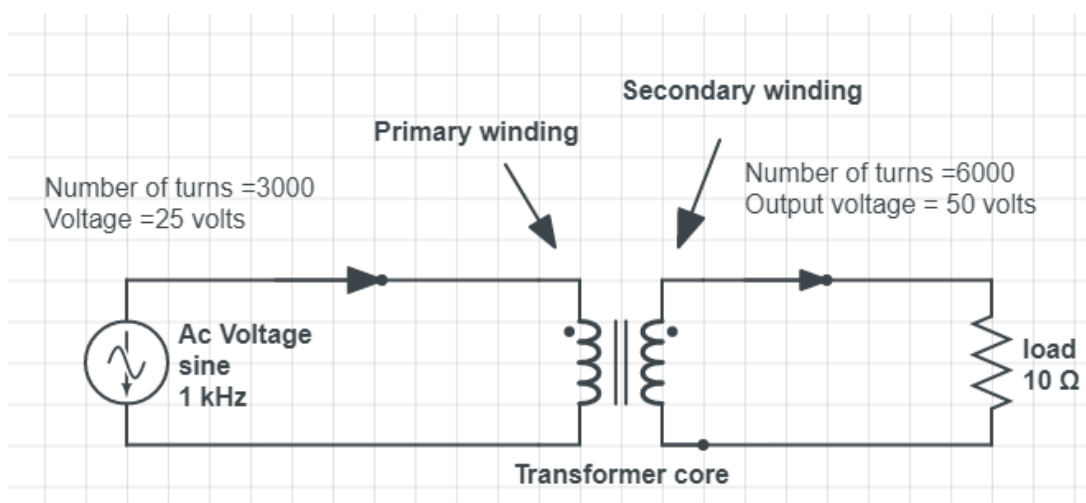

Figure 3. Step-up transformer

### 3.2.2 Step-down Transformer

It is a type of transformer which is used for decreasing the output voltage. In these types of transformer number of turns in the secondary coil is less than the number of turns in the primary coil. These types of transformer are used to decrease the voltage to a lower level. In figure 4. We can see the step-down transformer to decrease the voltage. Here, the number of turns in the primary coil is 120 and a voltage of 480 volts is supplied and on the secondary side we can see the number of turns is 30 which is less than the primary coil and the voltage is also less.

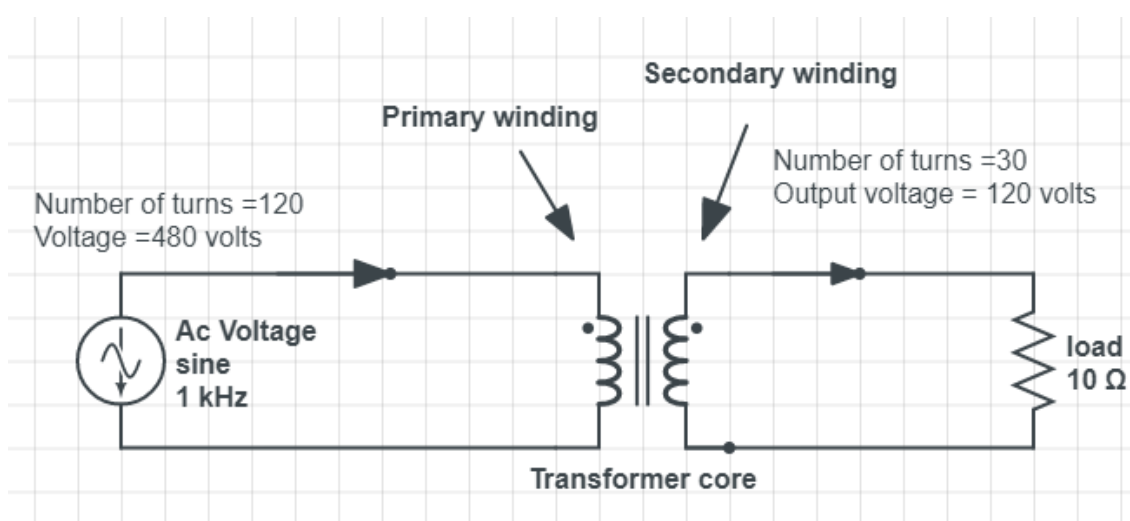

Figure 4. Step-down transformer

The transformer follows the principle of Magnetic Induction also called Mutual Induction as shown in figure 5. The transformer is a completely solid-state device. It consists of two or more coils of insulated wire. When voltage is given to one coil which is also called the primary coil, it magnetized the core and then a voltage is induced in the other coil also called Secondary coil or Output coil. The voltage between the primary coil and the secondary coil depends on the number turns in the primary and secondary coil. When two coils are wound on a single ferromagnetic core, effectively all of the flux produced by the primary coil is linked with the secondary coil so there is no flux loss.

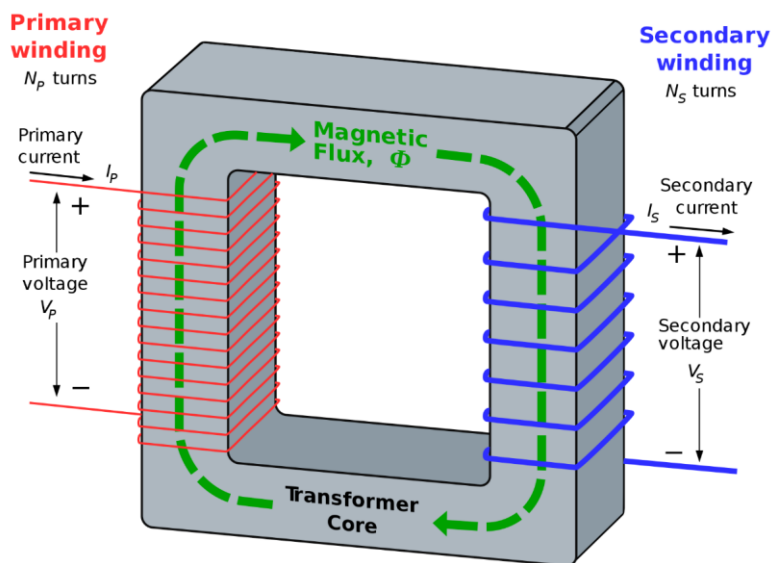

Figure 5. Flux being generated in ferromagnetic core [5]

### 3.3 Ideal Transformer

An ideal transformer is a types of transformer which gives exactly equal output power to the input power. It is a theoretical linear transformer that is perfectly coupled. In these types of transformer, there are no copper losses (winding resistance is zero), no iron loss in core and no any flux leakage. It is 100% efficient.

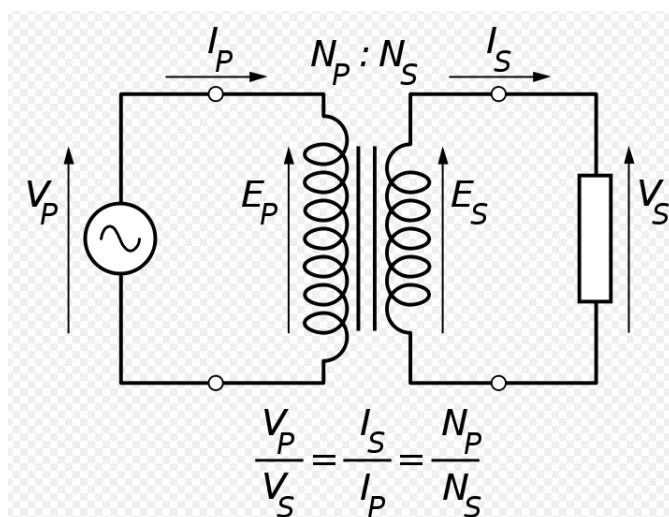

Figure 6. Ideal transformer [6]

Faraday`s law states "The electromotive force around the closed path is equal to the negative of the time rate of the change of the magnetic flux enclosed by the path. " [7]

$$V_p = -N_p \frac{d\phi}{dt} \dots \quad (1)$$

$$V_s = -N_s \frac{d\phi}{dt} \dots \quad (2)$$

Where,  $V$  is the instantaneous voltage supplied,

$N$  is the number of turns in each coil,

$d\phi/dt$  is the derivative of the magnetic flux  $\phi$  through one turn of the winding over a time ( $t$ )

Where,  $p$  and  $s$  denotes the primary and secondary.

From equation 1 and 2 we get,

$$\text{Turn ration} = \frac{V_p}{V_s} = \frac{N_p}{N_s} = a \dots \quad (3)$$

Where, for a step-down transformer  $a > 1$ , for a step up transformer  $a < 1$ , and for isolation transformer  $a = 1$ .

By law of conservation of energy, all power are conserved in the input and output:

$$S = I_p V_p = I_s V_s \dots \quad (4)$$

Where,

$S$  is conserved power and  $I$  is the current.

And from eq.3 and eq. 4 gives the ideal transformer identity:

$$\frac{V_p}{V_s} = \frac{I_s}{I_p} = \frac{N_p}{N_s} = \frac{\sqrt{L_p}}{\sqrt{L_s}} = a \dots \quad (5)$$

Where,

L is winding self-inductance. [7]

### 3.4 Transformer Efficiency

The efficiency of the transformer is defined as the ratio of output power to the input power. As the output power is always less than the input power due to losses in the transformer.

The efficiency of an ideal transformer is equal to 1 or 100 % since the power loss in ideal transformer is zero. The efficiency of a transformer is shown in the figure 7. The transformer on which load is variable is designed to give maximum efficiency at about 75% of full load. The transformer has no moving parts the losses caused by the friction are absent. Efficiency is maximum in a transformer when copper losses = Iron losses.

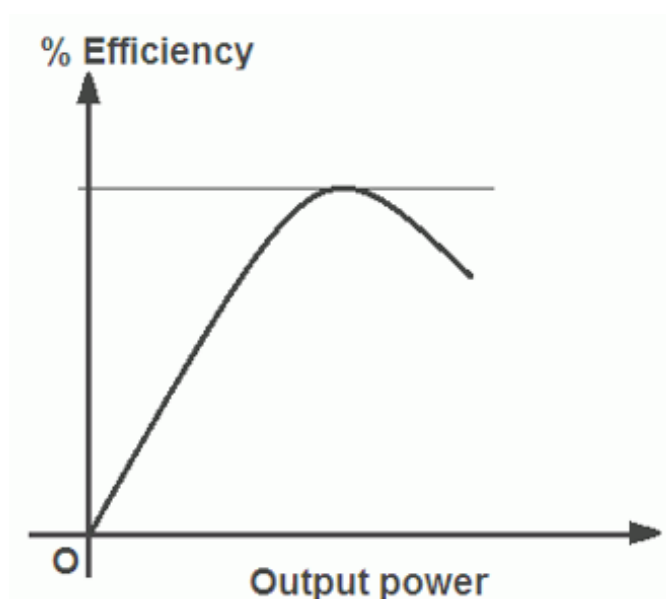

Figure 7. Output power versus efficiency. [8]

The efficiency of the transformer is denoted by “ $\eta$ ”

$$\text{Transformer efficiency, } \eta = \frac{\text{Output Power}}{\text{Input Power}} \dots\dots (6)$$

Input power = Output power + losses

$$\eta = \frac{\text{Output Power}}{\text{output Power} + \text{iron loss} + \text{copper loss}} \dots\dots (7)$$

$$\eta = \frac{V_2 I_2 \cos\phi}{V_2 I_2 \cos\phi + P_i + P_{cu}} \dots\dots (8)$$

Where,  $V_2$  = secondary terminal voltage

$I_2$  = secondary current

$\cos\phi$  = load power factor

$P_i$  = iron losses = hysteresis loss + eddy current loss

$P_{cu}$  = copper loss =  $I_2^2 R_{02}^2$

$R_{02}^2$  = Resistance of transformer on the secondary coil

Hence, Power efficiency is not the suitable terms for judging the performance of a transformer. However energy efficiency is the suitable terms for judging the efficiency of a transformer. The energy efficiency of a transformer is defined as the ratio of output energy (in kWh) to the input energy (in kWh) for twenty-four-hour. It means how long a transformer can operate efficiently. It is also known as all-day transformer. [9]

### 3.4.1 Eddy Current

Eddy current is also called Foucault's current. It is induced by the time-varying magnetic field in the transformer within nearby stationary conductors. It flows in closed loops within the conductor, in planes perpendicular to the magnetic field. Eddy current losses are the result of Faraday's law, which states "any change in the environment of a coil of wire will cause a voltage to be induced in the coil, regardless how the magnetic change is produced".

### 3.4.2 Hysteresis

Hysteresis loss is caused by the magnetization and demagnetization of the core as the current flows in the forward and reverse direction in AC supplies. This generates friction producing the heat in the core, which is a form of power loss.

### 3.4.3 $I^2R$ Loss

$I^2R$  Loss is another loss in the transformer as the components always have some resistance causing electrical losses that are dissipated as heat. It occurs in both AC and DC supplies. Following is the calculations:

$$V = IR \dots\dots (9)$$

Where,  $V$  = voltage (Volts) across a component

$R$  is the component's resistance (in Ohms) and

$I$  is the current in Amps through it.

$$P = VI \dots\dots (10)$$

Where,

V and I are as above, and

P = power dissipated in Watts.

From equation (9) and (10),

$$P = (IR) * I \text{ or } I^2R \dots\dots \quad (11)$$

This is known as copper loss. Such losses occur in their windings, so they are sometimes called winding losses. It can be reduced by improving the winding technique or using higher electrical conductive materials.

### 3.4.4 Power Factor

The power factor is the ratio of the real power flowing to the load and apparent power to the circuit. Because the transformer consists of coils, there is a backward current flow from the transformer to source causing the distortion in the waveform of the circuit increasing the THD (Total Harmonic Distortion) in the circuit. [10]

## 4 Methods and Materials

### 4.1 Materials

The material that is given in this project are ferrite core, diode, capacitor, voltage regulator, Resistor (load). The brief explanation is mentioned below about the materials provided with their application.

#### 4.1.1 Ferrite core

The ferrite core is used for making of the transformer as we need to transfer AC wirelessly. Here the ferrite core is used for making a transformer by winding the certain number of turns using wires. The number of turns used is similar in both primary and second-

ary coil, which is illustrated by the following figure. As electricity is induced in the secondary coil is due to electromagnetic flux so as the number of turns is increased more flux is generated. Figure 5 describes about transformer made from the ferrite core. The red wire is the primary side of the transformer and the blue wire is the secondary side of the transformer green color represent the induced magnetic flux in the transformer core. The figure generally describes about how current is transferred wirelessly in the transformer.

#### 4.1.2 Diode

A diode is an electrical component which allows current to flow in only one direction. Mostly diode is made of semiconductor materials like silicon, germanium or selenium. A diode can be used for various purposes such as rectifiers, voltage regulators, switches, signal modulators, oscillators. Here it is used for converting AC to DC, the process of converting AC into DC is known as rectification. Here diode is configured in a closed loop which looks like a bridge. This configuration on diode for rectification is also known as bridge rectification. For this configuration four diode is connected as shown in the figure 8. The figure 8 describe about the current flows through the circuit. At positive half cycle current flows through the D1 to load and from load to D2 and cycle is completed and at negative half cycle current flows through D3 to load and load to d4 to complete the cycle. During positive half cycle D3 and D4 are reverse biased and during negative half cycle D1 and D2 are reverse biased.

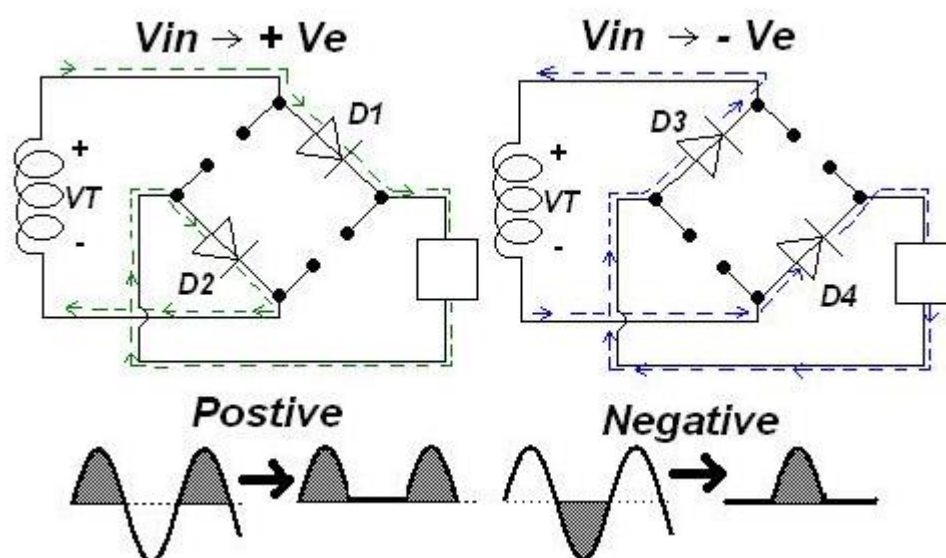

Figure 8. Postive half-cycle and negative half-cycle. [11]

#### 4.1.3 Capacitor

A capacitor is an electrical device that stores electrical energy in an electric field. An ideal capacitor is characterized by a constant capacitance ( $C$ ) in farads. It is defined as the ratio of the positive or negative charge 'Q' on each conductor to the voltage between them.

$$\text{Therefore, } C = \frac{Q}{V}$$

The effect of the capacitors is known as capacitance. Capacitance is defined as the ratio of the electric charge on each conductor to the potential difference between them. There is two capacitor of different values that have been used in a lab experiment. The two different values are  $220\mu\text{f}$  and  $47\mu\text{f}$  which is shown in figure 10.



Figure 9. Two Capacitor 47 $\mu$ f and 220 $\mu$ f respectively used in lab.

#### 4.1.4 Voltage Regulator

A voltage regulator is an electrical device that automatically maintains a constant voltage level. It is used to regulate one or more AC or DC voltages. Voltage regulator is used in many electrical devices such as computer power supplies to stabilize the DC voltages that is used by the processor or other elements and other power station where they control the output power.

The regulator that have been used in lab is LM78L05. The LM705 have internal thermal overload protection, internal short circuit current limit, output current of 100 mA. Output transistor safe area protection and uses no external components and available in plastic. At last, output voltage of 5.0 V, 6.2 V, 8.2 V, 9.0 V, 12 V, and 15 V are available. The characteristics of LM78L05 is described in the figure 11. The figure describe about the output pins and circuit connection showing how the voltage regulated functions and connected respectively. In the picture of circuit connection two capacitor are used so that it can reduced ripple voltage. Here the first figure represent the physical structure of a regulator showing the pins configuration .It is 3 pins device as shown in the figure 11 one pin for Output, one is for Ground purposes and one is for unregulated input voltages. As it provides constant +5 V output to the power small loads of less than 100 mA. And the second figures tell about the supplied input voltages in order to get maximum 5.25 V. [12]

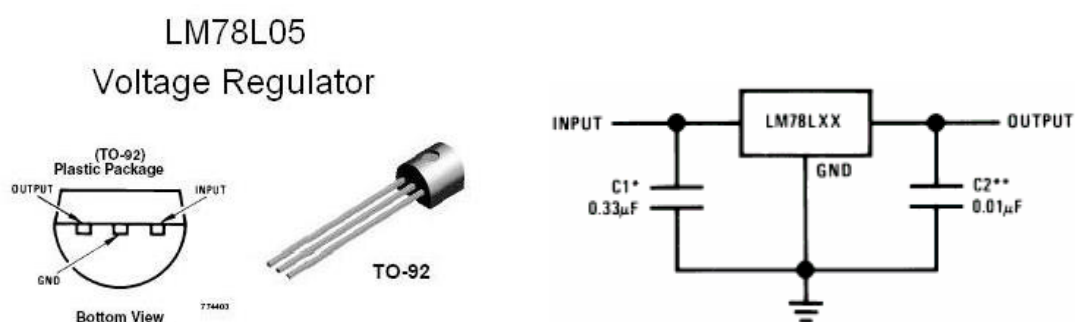

Figure 10. Voltage Regulator Pinout of LM78L05 and circuit connection [12]

<b>LM78L05</b>						
Unless otherwise specified, $V_{IN} = 10V$						
Symbol	Parameter	Conditions	Min	Typ	Max	Units
$V_O$	Output Voltage		4.8	5	5.2	V
		$7V \leq V_{IN} \leq 20V$ $1mA \leq I_O \leq 40mA$ (Note 3)	4.75		5.25	
		$1mA \leq I_O \leq 70mA$ (Note 3)	4.75		5.25	
$\Delta V_O$	Line Regulation	$7V \leq V_{IN} \leq 20V$		18	75	mV
		$8V \leq V_{IN} \leq 20V$		10	54	
$\Delta V_O$	Load Regulation	$1mA \leq I_O \leq 100mA$		20	60	mV
		$1mA \leq I_O \leq 40mA$		5	30	
$I_O$	Quiescent Current			3	5	mA
$\Delta I_O$	Quiescent Current Change	$8V \leq V_{IN} \leq 20V$			1.0	
		$1mA \leq I_O \leq 40mA$			0.1	
$V_n$	Output Noise Voltage	$f = 10 \text{ Hz to } 100 \text{ kHz}$ (Note 4)		40		$\mu V$
$\frac{\Delta V_{IN}}{\Delta V_{OUT}}$	Ripple Rejection	$f = 120 \text{ Hz}$ $8V \leq V_{IN} \leq 16V$	47	62		dB
$I_{PK}$	Peak Output Current			140		mA
$\frac{\Delta V_O}{\Delta T}$	Average Output Voltage Tempco	$I_O = 5mA$		-0.65		mV/°C
$V_{IN} \text{ (Min)}$	Minimum Value of Input Voltage Required to Maintain Line Regulation			6.7	7	V
$\theta_{JA}$	Thermal Resistance (8-Bump micro SMD)			230.9		°C/W

Figure 11. LM78L05 Datasheet [12]

## 4.2 Circuit Design and Analysis

The goal is to transfer the AC current from the source wirelessly using transformer and convert that output AC current to the DC Current and voltage have been stabilized the voltage using voltage regulator. As transformer works only when AC voltage is applied to the primary coil, if DC Voltage to primary coil, no voltage appears across the secondary coil therefore, source must be AC. After getting voltage on secondary coil the task is to convert that output AC to DC. The process of turning AC into DC is called rectification. Diode have been used in a bridge configuration which is also known as bridge rectification. Output of that current is Direct current. Before the circuit is designed in hardware, first circuit have been designed in a software using NI Multisim and the data have been analyze to be more certain. Following figure 12 is the circuit that has been designed in the NI Multisim and the circuit is also simulated.

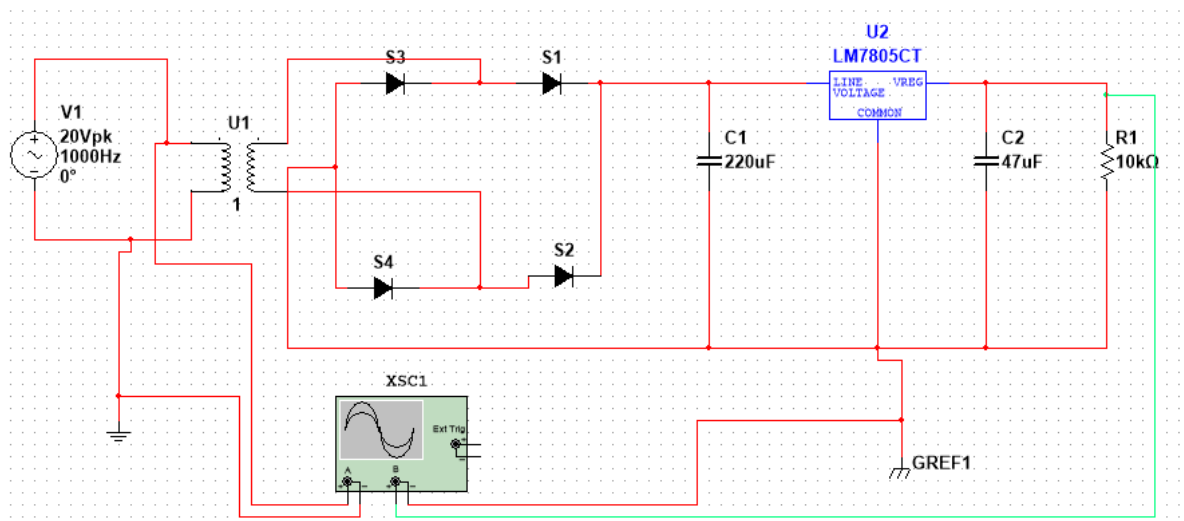

Figure 12. Circuit diagram of wireless power transfer using NI Multisim

The figure 13 is the Oscilloscope display showing the output of the circuit that have been stimulated. As the output after simulation is 5 volt DC and the circuit worked just fine then hardware is designed accordingly.

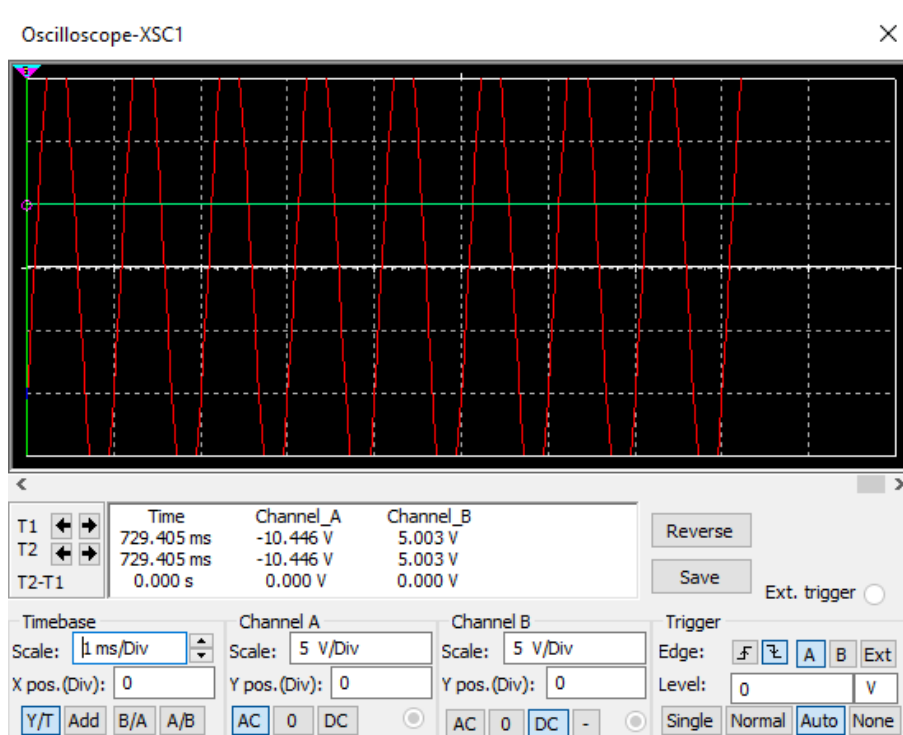

Figure 13. Stimulation reading on Oscilloscope.

## 5 TESTS AND RESULTS

### 5.1 Measurement Setup

Measuring the effect of frequency and amplitude of the input source voltage to the output load was the most crucial part of this project. There was no external circuit designed to delivery power to the system instead a standard voltage generator was used, therefore changing the amplitude and frequency was convenient and more reliable to observe their effects on the load.

Furthermore, changing transformer parameters namely the number of turns in the primary and the secondary coil had also significant effect in the magnitude of magnetic field and magnetic flux. Therefore, the effect of transformer parameters was also observed and analyzed. Since the effects of all affecting factors was observed in the magnitude and phase of output voltage, oscilloscope was used to monitor all the change produced

by setting different values of input frequency, input voltage and number of turns around transformer.

In this first phase of the observation number of turns in primary coil was set to 20 and the number of turns in the secondary coil was set to 25. When observed with fewer turns significantly low value was observed at the load and it was as expected since the lower number of turns in transformer yields very small magnetic flux and consequently very small induced current in secondary coil.

The effect of changing frequency to the output voltage at secondary coil and ultimately at the output load was the major interest of. The voltage supplied through the function generator was made constant to 10 V while observing effect of frequency. As the transformer worked as step-up voltage the voltage across the secondary coil is more than the voltage in primary coil.

Basically, the frequency of input voltage at the transformer has direct proportional effect to the magnetic flux produced at the secondary coil as stated by Faraday's law. Although the magnetic field produced by the input coil remains constant for constant voltage and current, the change in magnetic flux increases by changing increased frequency and more magnetic flux yields more voltage at secondary coil. The similar effects were observed and illustrated in table 2 and figure 14.

Table 2. Different voltage on different frequencies of ferrite coil

Frequency (kHz)	Voltage at Primary coil	Voltage at Secondary coil
5	1,88	2,24
10	3,32	3,88
20	5,28	6,12
30	6,36	6,8
70	7,28	7,76
100	7,36	7,96
200	9	10,2
500	9,2	10,8
1000	9,4	11,2
2000	9,4	15,2
3000	9,2	32,8
4000	8,6	48
5000	9	12,4
6000	8,8	7,2
7000	8,8	5,2
8000	8,6	4
9000	8,8	3,6
10000	8,4	3,2

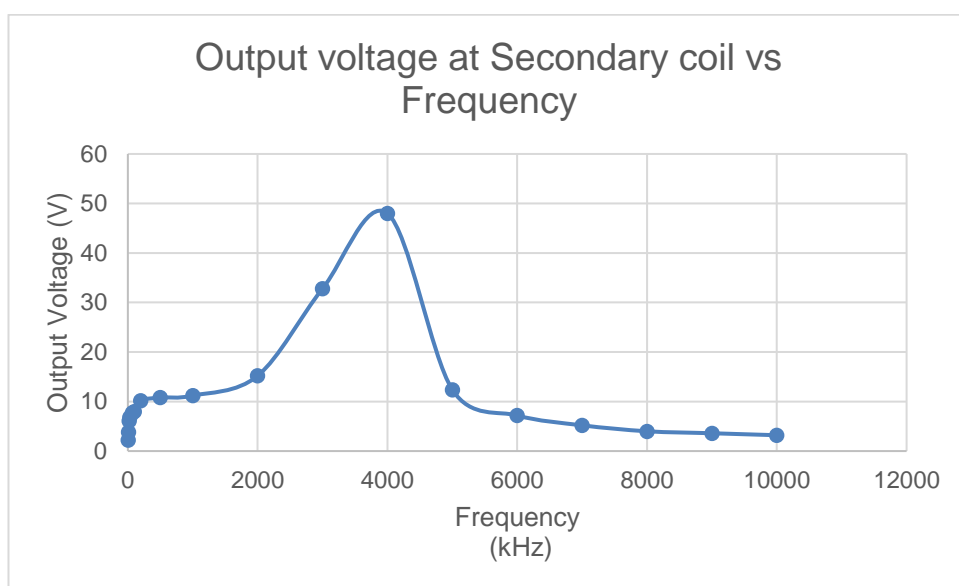

Figure 14. The relation between the varying frequency and the output Power at secondary coil.

The figure 15 describes the relation between the frequencies and the output voltage. In the figure different voltages with different frequency is supplied through the

circuit. Until the frequency is raised to 30 kHz significant low voltage is produced in secondary coil because of the very small magnetic flux generated by this frequency at secondary coil. As shown in figure 14. With gradual increase in frequency yields more voltage is produced at secondary side. The voltage increases linearly from 500 kHz to 4 MHz

At 4 MHz frequency the maximum output voltage is obtained in the secondary coil because of the resonance of parasitic capacitor inside inductor and inductor itself. Due to the resonant phenomenon, impedance due to capacitor and inductor are compensated by each other and only the parasitic resistor inside the coil, which is of very small value remains dominant. Since the only impedance to create loss of electrical current produced in the secondary coil is small resistor of coil larger portion of electrical current and voltage is transferred in the secondary coil. Thus, a very large peak in output voltage at secondary coil was observed at the resonant frequency.

Further increase in frequency caused a sharp decrease in the output voltage at secondary coil in exponential nature as shown in figure 14 and table 2 from row 13. That phenomenon was observed as expected since further increase in frequency beyond resonant produced larger impedance in inductor and it becomes significantly dominant factor to create electrical losses. Therefore, as illustrated in fig. 14 voltage goes on decreases exponentially till 5 MHz and further continues to decrease until 10 MHz

This voltage on the secondary coil is measured using digital multi-meter or oscilloscope in lab and the source is function generator. Various reading is collected and it is represented as graph using Excel sheet.

Another data is collected when the number of turns in primary and secondary coil of the transformer is similar i.e.  $N_1=20$  and  $N_2=20$ . As the purpose of this another test is to make an ideal transformer so that we can get more efficient data. As there is always energy loss so it is impossible. Although the voltage on each primary and secondary coil is somehow efficient. In order to get output voltage at the load (5 V output voltage) from the rectified circuit, the input voltage supplied to the regulator must above 7 voltage, as the regulator needs voltage in-between  $\geq 7 \text{ V} \leq 20 \text{ V}$ . Which is described in the datasheet of the voltage regulator. The supplies voltage from the function generator

is 20 V. The supplied frequency is from 1 kHz to 600 kHz. In table 3 the required output voltage at the load can be generated at 200 kHz to 600 kHz.

Table 3. Voltage at secondary coil and load resistor with varying frequency

Frequency (kHz)	Voltage at Secondary coil	Voltage at Load
1	0	0
10	1,2	0,52
15	3,2	1,69
20	5,6	2,5
30	9,8	3,06
50	13	3,75
80	14,4	4,31
100	14,8	4,45
150	15,2	4,49
200	16	4,89
250	17,2	4,99
300	18,8	4,99
350	19,66	4,99
400	20	4,99
500	17,8	4,99
600	14,4	5

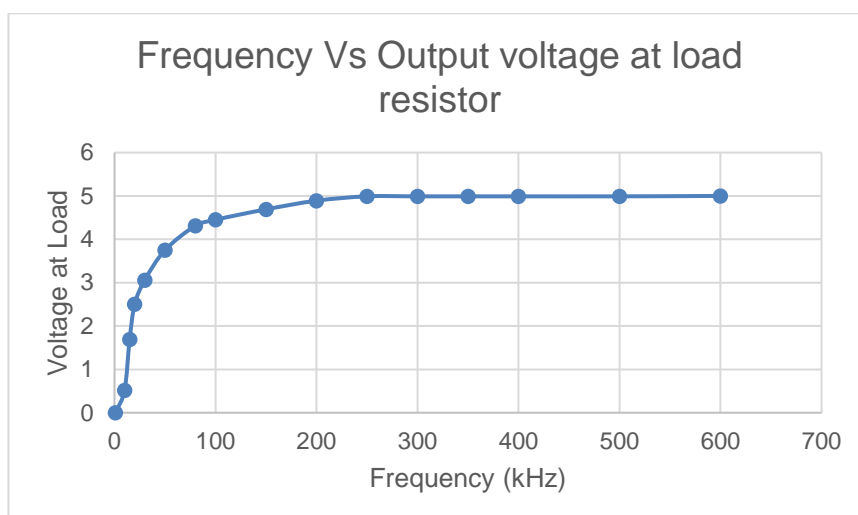

Figure 15. Relation between Output voltage and frequency

The figure 16 describes about the required voltage at the output. At the frequency of 200 kHz required voltage at the load is generated till the frequency is raised up-to 600 kHz. At we get the required voltage on secondary coil at from the frequency 30 kHz but the regulator cannot give the required voltage at the load. The regulator is not working

properly at that frequency. The reading of the voltage at the load is taken by using digital multi-meter in the lab. At low frequency the primary coil cannot produce enough magnetic flux so the current cannot be produced in the secondary coil. As the frequency is increased more flux generated and current is induced in the secondary coil. Resulting the increase in voltage.

Another data when the number of turns in primary coil is 20 and number of turns in secondary coil is 25. Data is in table 4. Here, output voltage is measured in two different circuit one is after the rectification and another reading is done at load. The reading is measured by using digital multi-meter. Required output voltage can be seen at the frequency 40 kHz till 600 kHz.

Table 4. Voltage after rectification and at load resistor with varying frequency

Frequency (kHz)	Voltage after rectification	Voltage at load resistor
10	3,34	2,26
20	5,23	3,92
30	6,13	4,78
40	6,54	4,99
50	6,8	4,99
100	7,07	4,99
120	7,13	4,99
150	7,5	4,99
200	8,06	4,99
250	8,66	4,99
300	8,92	4,99
350	10,51	4,99
400	11,16	4,99
450	11,3	4,99
500	6,38	4,99
550	5,94	4,62
600	5,33	4,03

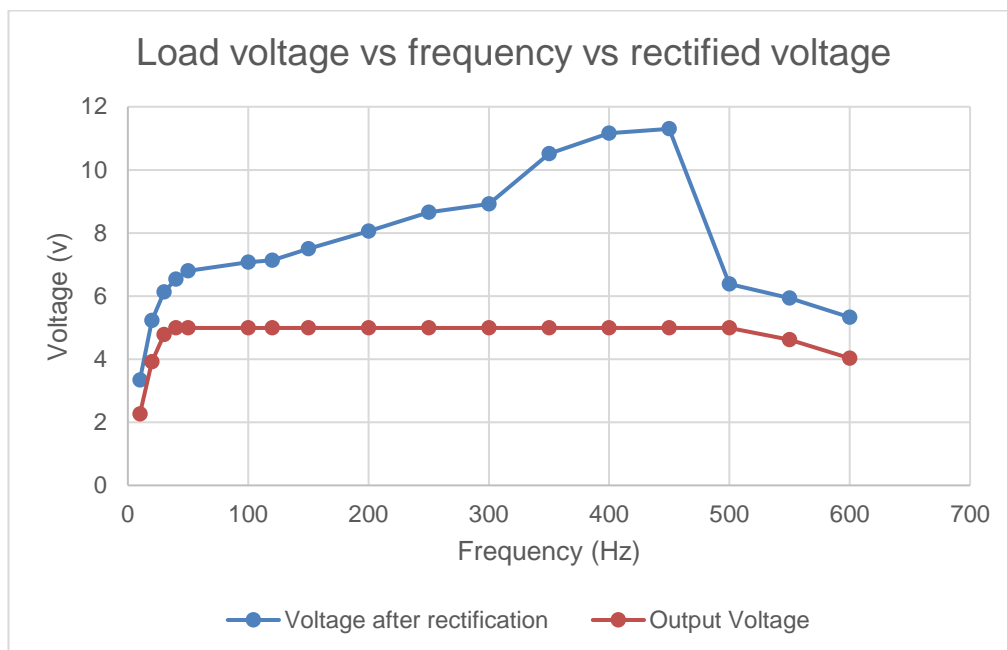

Figure 16. Relation between Voltages after rectification and voltages at load

The collected data from the measurement is displayed in the figure 16. The figure 16 shows the two different characteristics. The red line with the dots tells us about the voltage at the output when the frequency is changed from the 1 kHz to 600 kHz. As the target of the project is to get the 5 V at the load. When the frequency is increased to 40 kHz from 1 kHz required voltage is generated up-to the 500 kHz then slowly voltage drops.

## 6 Conclusion

From the above various data and the reading the required voltage is obtained. Various tests are performed in the lab. Before the test is done at first it is simulated using the National Instruments Multisim software and required result is obtained. Three different tests are done in the lab. For this project general function generator is used as source of power. The circuit is made on the bread-board. Ferrite core is used for making of the transformer and the result are monitored in oscilloscope.

First test is done to understand the effect of frequency in transformer. As the frequency is increased the voltage at secondary coil is induced due to electromagnetic induction. And the figure 14 shows that the voltage increases with the increasing frequency up-to certain range and again the voltage start to drop. After knowing the effect of frequency in the inducing flux our target is to get the required output voltage (5 V). Here, the required voltage is obtained at frequency 150 kHz till the frequency reach up-to 600 kHz which is also shown in figure 15. Third test is also done by changing the number of turns in secondary coil as we change the number of turns, transformer worked as step-up transformer and in this case output voltage is generated at frequency 40 kHz till 500 kHz.

Hence the target of this project is to understand the effect of frequency in the transformer and to generate the required DC voltage as this voltage can be used in many purposes like charging the phone battery, toothbrushes, or any electrical recharge able device that uses dc volt for the charging.

## 7 References

- [1] "Wireless Power Transfer," [Online].  
Available: [https://en.wikipedia.org/wiki/Wireless\\_power\\_transfer](https://en.wikipedia.org/wiki/Wireless_power_transfer). [Haettu 17 12 2019].
- [2] "General Function of Transformer," 2019. [Online].  
Available: <https://www.edgefxkits.com/blog/>. [Haettu 17 11 2019].
- [3] "Nikola Tesla," [Online].  
Available: [https://en.wikipedia.org/wiki/Nikola\\_Tesla](https://en.wikipedia.org/wiki/Nikola_Tesla). [Haettu 27 08 2019].
- [4] "Nikola Tesla," [Online].  
Available: [https://en.wikipedia.org/wiki/Nikola\\_Tesla](https://en.wikipedia.org/wiki/Nikola_Tesla). [Haettu 02 12 2019].
- [5] "Flux generated in ferromagnetic core," [Online].  
Available: <https://www.quora.com/Why-can-a-transformer-only-change-voltage-of-an-alternating-current>. [Haettu 02 12 2019].
- [6] "Ideal Transformer," 2019. [Online].  
Available: <https://www.electricaltechnology.org/2012/02/ideal-power-equation-of-transformer.html>. [Haettu 15 10 2019].
- [7] "Transformer," [Online].  
Available: <https://en.wikipedia.org/wiki/Transformer>. [Haettu 10 11 2019].
- [8] "Transformer efficiency," [Online].  
Available: <https://www.yourelectricalguide.com/2017/08/transformer-efficiency.html>. [Haettu 02 12 2019].
- [9] "Transformer Efficiency Formula & Calculation," 10 september 2019. [Online].  
Available: <https://www.yourelectricalguide.com/2017/08/transformer-efficiency.html>.
- [10] "Transformer - Losses And Efficiency," [Online].

Available: <https://www.electriceasy.com/2014/04/transformer-losses-and-efficiency.html>. [Haettu 22 10 2019].

[11] "Electrical Engineering," [Online].

Available: <https://electronics.stackexchange.com/questions/61547/negative-and-positive-cycle-of-ac-current-half-wave-rectification-and-full-wave>. [Haettu 22 11 2019].

[12] "Datasheet of LM78L05," [Online].

Available: <http://www.ti.com/lit/ds/snvs754k/snvs754k.pdf>. [Haettu 02 12 2019].

[13] "Datasheet of LM78L05," 02 12 2019. [Online].

Available: <http://www.ti.com/lit/ds/snvs754k/snvs754k.pdf>.