

Mikhail Surudo

T639KA

MODERN CHILLED BEAM TECHNOLOGY

Bachelor's thesis
Building Services Engineering
Double Degree Program

March 2011



MIKKELIN AMMATTIKORKEAKOULU

Mikkeli University of Applied Sciences

DESCRIPTION

 <p>MIKKELIN AMMATTIKORKEAKOULU Mikkeli University of Applied Sciences</p>		Date of the bachelor's thesis 30.03.2011
Author(s) Mikhail Surudo	Degree programme and option Building Services Engineering Double Degree Program	
Name of the bachelor's thesis Modern Chilled Beam Technology		
Abstract <p>The subject of the project was a research about the modern chilled beam technology. The thesis starts with literature review. In the first part it contains theoretic base for clear understanding of chilled beam technology. It includes definitions of chilled beam, principle of operation, main characteristics, and heat transfer methods. In the second part there is practical knowledge for designing systems with chilled beam. This research is aimed to become an introductory text for Russian HVAC designers. It discusses operation scheme, requirements to room constructions, requirements to location, rules for selection etc.</p> <p>Chilled beam is a modern device for ventilation and cooling or heating where there are requirements for individual regulation of the temperature. The main purposes of chilled beam using are cooling and ventilating of air. This air conditioning unit provides excellent thermal comfort with good energy efficiency. It has some advantages over the other air-water systems and over all-air VAV systems that were described in my thesis. The maintenance is easy and needs less human resources than other systems. Also this system is adapted for free cooling and sustainable heat source. The active chilled beams can remove large amounts of sensible heat and at the same time this system reduces primary air flow requirement. Also integrated services can be used. The lifecycle cost of chilled beam system is low.</p> <p>The research has shown that the chilled beam system is very useful to provide excellent working environment that has a good effect on the health of people and their productivity.</p>		
Subject headings, (keywords) Chilled Beam, Climate Beam, Active Chilled Beam, Passive Chilled Beam, Cooling, Heating, Ventilation		
Pages 26	Language English	URN
Remarks, notes on appendices		
Tutor Aki Valkeapää	Employer of the bachelor's thesis	

CONTENTS

1	INTRODUCTION.....	1
2	DESCRIPTION OF THE SYSTEM	2
2.1	Definition of chilled beams	2
2.2	Principle of operation	4
2.3	Indoor climate with chilled beams.....	4
2.4	Operation range	6
2.5	Heat transfer methods	7
2.6	Comparison with other air-water systems	8
2.7	Applications	9
3	DESIGNING A SYSTEM WITH CHILLED BEAMS	9
3.1	Operation scheme	11
3.1.1	Cooling with active chilled beams.....	12
3.1.2	Heating with active chilled beams	13
3.1.3	Active chilled beams in hot and humid climates	13
3.1.4	Prevention of condensation.....	14
3.2	Position of chilled beams.....	16
3.2.1	Active chilled beams.....	16
3.2.2	Passive chilled beams	16
3.3	Design requirements to room construction.....	17
3.4	System of air and water supply.....	18
3.4.1	Pipes.....	18
3.4.2	Ducts	19
3.4.3	Use of free cooling and sustainable heat source	19
3.5	Room control	20
3.6	Integrated technical services.....	20
3.7	Selection of chilled beams	21
3.8	Design software	22
4	INSTALLATION AND COMMISIONING.....	22
5	OPERATION AND MAINTENANCE	23
6	THE MANUFACTURERS AND SUPPLIERS	24
7	CONCLUSION	24

BIBLIOGRAPHY	26
--------------------	----

1 INTRODUCTION

All people prefer to live and work in a good and comfort climate but not everyone is familiar with complicated process of creation of excellent environment conditions. Making the indoor climate suitable for people and modern systems of air conditioning is extremely attractive and motivating for me, as it is the area of my specialization. The subject matter of my thesis is the chilled beam air conditioning system. In my research work I have been exploring and made a close study of this system as a new HVAC technology.

It is a well-known fact that the problem of saving energy has become more and more fundamental and it is under discussion since the last decades. In a contemporary society a lot attention is given to this problem and its solutions. Numerous aspects have already faced a progress on the way of energy consumption reducing. Some of them have been engineered absolutely new and innovative. The humanity constantly develops and makes an effort to reach the perfection in all spheres of life. But along with energy saving people are also concerned about realization of the most comfortable conditions for life and work, safety of the health and preservation of the environment. All these issues are closely related to each other: as a decrease in energy consumption leads to a reduction in energy production, the significant result is the decrease in harmful emissions into the environment. One of the devices which is able to do it is the chilled beam system: it is an effective tool and efficient solution for building a sustainable and environmentally-sensitive HVAC system.

The purpose of this project is to acquaint you to these advanced systems. This thesis discusses their applications, designing, operation scheme, location, selection, installation and commission in order to produce a more widespread integration. Its purpose is also to function as an introductory text for Russian HVAC designers. These systems are not yet widely spread and used in Russia and therefore this research work is very useful.

Chilled beam units are becoming increasingly popular in building design. When you need energy effective system, that includes radiant cooling, heating and also ventilation, chilled beams is an excellent solution. These units systems decrease energy con-

sumption in buildings and bring a right climate that makes people feel good and comfortable. It should be noted that chilled beam provides a quiet draught free comfort with high cooling capacity and stylish interior. Generally chilled beams are used in the commercial buildings, offices, hotels, universities, schools and hospitals.

The thesis starts with literature review. In the first part it contains theoretic base for clear understanding of chilled beam technology. It includes definitions of chilled beam, principle of operation, main characteristics, and heat transfer methods. Also this work includes debates about creation of good indoor climate with chilled beam and also benefits compared with other air-water systems. In the second part there is practical knowledge for designing systems with chilled beam. It discusses operation scheme, requirements to room constructions, requirements to location, rules for selection etc. Some information about design software and design cases also can be found in my work. Also materials about installation and commissioning, operation and maintenance are presented in this thesis. Moreover, it includes information about industrial manufacturers and suppliers, their types of chilled beams.

After carefully studying this work the reader will have a clear picture of how the chilled beam system works, how to design systems with chilled beam and the reasons for using it in the project of ventilation system. Main points of the research work can be read in the conclusion of the thesis. Let's get to know better about this modern chilled beam system.

2 DESCRIPTION OF THE SYSTEM

Chilled beam is a modern device for ventilation and cooling or heating where there are requirements for individual regulation of the temperature. The main purposes of chilled beam using are cooling and ventilating of air.

2.1 Definition of chilled beams

Chilled beam method appeared in the middle of the last century. It came into usage in the 90-s in Europe and America. Today these systems are widely spread and used in Europe, less known in U.S.A, but not used in Russia.

This air conditioning unit provides excellent thermal comfort with good energy efficiency. Chilled beam system gives possibility for individual temperature control. The maintenance is easy and needs less human resources than other systems. Also this system is adapted for free cooling and heating.

Definition of the chilled beam: “A cooled element or cooling coil situated in, above or under a ceiling which cools convectively using natural or induced air flows. The cooling medium is usually water.”/8, p. vii/

According with principle of operation this device has two types: active chilled beam and passive chilled beam. In the next paragraphs we will take a closer look into this.

Active chilled beams

Definition of the active (ventilated) chilled beam: “A convector with integrated air supply where primary air, induced air or primary air plus induced air passing through the cooling coil(s). The cooling medium in the coil is water. The beam is normally mounted under the ceiling.” /8, p. vii/

In accordance with the way of induction of secondary air the active chilled beams are subdivided to open and closed chilled beams. The open chilled beam can be defined as “an active chilled beam where secondary air is taken in into the top of the beam. Open chilled beams are mainly used without a suspended ceiling.”/8, p. viii/ The closed chilled beam is: “An active chilled beam where there is an integrated secondary air path directly from the room space. Closed chilled beams are mainly situated within a suspended ceiling. The cooling medium is usually water.”/8, p. vii/

Passive chilled beams

Definition of the passive chilled beam (static beam): “The cooled element or cooling coil fixed in, above or under a ceiling fitted with a cooling coil mainly convectively using natural airflows. The cooling medium is usually water.”/8, p. viii/ The principle of operation will be more carefully described in the next section.

2.2 Principle of operation

Principle of operation of active chilled beam and passive chilled beam are different. First of all it depends on its construction.

Active chilled beam is a device where the primary air is supplied to the plenum of active chilled beam by ducts from air handling unit. After that it is discharged through nozzle plates in the unit. The supply air nozzle jets induce indoor air. The induced air flows through the water coil, where it is either heated or cooled. Usually the temperature of cold water is 14-18°C and 30-45°C is the temperature of warm water. For the control of indoor temperature the water flow rate is regulated. Then primary air and secondary air are mixed in the chilled beam and diffused to the room space through outlet slots located at the bottom of the beam. /4./

Modern active chilled beams have one or two water coils, in other words they can be connected either to 2-pipe system for heating or cooling as well as to 4-pipe system for heating and cooling.

Passive chilled beam is simpler device than active chilled beam. It is like a chilled ceiling and also does not have connection with ventilation system. Passive chilled beams are used for cooling and heating like all air-water units. It is based on the principle of natural convection. Circulating air is flowing down through coil under the gravity. The air flow through the chilled beam is determined by the temperature difference (actually the difference in density) inside and outside the beam. Cooling output requirements are met by regulating the flow of chilled water through the beam heat exchanger. This is controlled by a combination of room thermostat and 2-port valve. /2./

2.3 Indoor climate with chilled beams

Health, working efficiency, people well-being depend on indoor climate conditions of buildings or other enclosed spaces where people spend long periods of time. Of course

aim of our chilled beam systems consists of in ensuring these healthy, safe and comfortable indoor climate conditions.

But before considering indoor climate with chilled beams firstly let's look what is "indoor climate" and how it is defined. Indoor climate is a combination of parameters that characterize the conditions of indoor space. Indoor climate is composed of the following factors: thermal conditions, air quality, acoustic conditions and lighting conditions. /5./

Comfortable thermal conditions should be ensured by chilled beam. It is achieved via right definition of designing air velocity in the occupied zone and specific cooling output. Both these parameters should be taken into account to prevent the risk of draught. To guarantee good conditions in premise, the building should be designed so that heat loads can be in recommended range. It should be below 80 (max 120) W/floor-m². Table 1 shows values of interdependency between the maximum cooling output of the chilled beam system and the supply airflow rate. This table should be used as a guideline and of course all particular cases should be checked. Also the table 2 shows the recommended indoor climate targets values.

TABLE 1. Interdependency between the maximum cooling output of the chilled beam system and the supply airflow rate /8, p. 14/

Airflow rate (l/s,m ²)	Cooling capacity (W/m ²)
1.5	... 70
2	... 90
3	... 120

Heat loads and transient heat transfer effects of the thermal mass of the construction should be taken into account during the calculation of required cooling capacity. Chilled beam may be selected with some reserve for the compensation of the future potential increases in heat loads. Position of passive chilled beams should be designed with respect to the location of heat load. Minor increase in productivity may be achieved through the right positioning of passive chilled beams. Also while locating of chilled beams the designer should pay attention to the possibility of future layout

changes within the space. This will be useful for office buildings especially for those which are rented. /8./

TABLE 2. Recommended indoor climate targets values /8, p. 14/

	Summer	Winter
Comfort		
PVM	-0,5...+0,5	-0,5...+0,5
Temperature		
Operative room air temperature	24,5±1,5°C	22±2°C
Vertical air temperature deference (0,1...1,1 m)	<3°C	<3°C
Radiant temperature asymmetry of windows	<23°C	<10°C
Radiant temperature asymmetry of ceiling	<14°C	<5°C
Floor surface temperature	19...26°C	19...26°C
Air Quality		
Outdoor air requirement per floor area	1,5...3 l/s,m ²	1,5...3 l/s,m ²
Outdoor air requirement per person	8...20 l/s,m ²	8...20 l/s,m ²
Air Velocity		
Draught rating (DR)	<15%	<15%
Average air velocity in the occupied zone (PMV=0)	0,18 m/s	0,15 m/s
Maximum air velocity in the occupied zone	0,23 m/s	0,18 m/s
Air Humidity		
Relative humidity	30...55%	25...40%
Acoustics		
Sound level requirement	NR15-NR30	NR15-NR30

2.4 Operation range

Recommended water inlet temperature for cooling is 14 ... 16 °C. It depends on dew point temperature of the room air. Water inlet temperature for heating is 35 ...45 °C. Pressure losses of chilled beams are the same as in the pipe line. Minimum water flow rate is shown in the table 3. /8, p.4/

Firstly, active chilled beam will be described. Primary air from nozzles (5 ... 12 l/s/m) induces 3 ... 5 times the room air. The mixed air flow rate of 15 ... 60 l/s/m is discharged into the room from one or two slots. In addition normal duct pressure level should be 70 ... 120 Pa. For achieving comfort conditions the required cooling demands should be under 120 W/floor-m². For good thermal comfort the optimum cooling capacities should be 60 ... 80 W/floor-m². Heating capacity for active chilled

beams is 40 (max 60) W/m^2 . Passive chilled beams are used when required cooling capacities are 40-80 W/floor-m^2 . Usually passive chilled beams are not used for heating. /2./

2.5 Heat transfer methods

Heat transfer method in chilled beam is mainly based on convection via heat exchanger. Convection is based on the motion of air layers. If temperature of heat exchanger is higher than the indoor air it emits heat to the room air. And just the same process happens if indoor air is warmer than heat exchanger. The causes of convection generally can be natural and forced. In passive chilled beam the principle of work is established on natural convection. Natural convection occurs due to the density difference of the air layers. The layer with higher density (which corresponds to the lower temperature) flows down and the layer with the lower density floats up. In active chilled beam the heat transfer functions with forced convection. Forced convection is the flow of air induced by mechanical power e.g. fan.

Another important question related to heat transfer is heat transfer efficiency. The heat transfer in the chilled beam exchanger depends on several moments:

- Water mass flow rate.
- Coil and pipe dimensions.
- Primary airflow and induction airflow rates. Induction rates depend on the construction and quantity of nozzles.
- Temperature difference between room air and inlet water.

To achieve good efficiency water flow rate should be enough to guarantee turbulent air flow according to the design conditions. Turbulent flow gives more effective heat transfer than laminar flow. Table 3 shows minimum water flow rate with different pipe diameter to ensure fully turbulent flow. /8, p.4/

TABLE 3. Minimum water flow rate with different pipe diameter to ensure fully turbulent flow /8, p.4/

Outside diameter (mm)	Water velocity (m/s)	Minimum water flow rate (kg/s)
10	0.28	0.016
12	0.23	0.018
15	0.18	0.024
18	0.15	0.030
22	0.12	0.038

2.6 Comparison with other air-water systems

Chilled beams have done advantages over the other types of air-water systems devices. The chilled beams promote excellent thermal conditions. There is no moving part like in fan coil unit and it means that these systems do not need electric connection, maintenance of actuator and changing of wearing parts. Also it is quiet operation air system. There is no drain system like in fan coil and split units. Chilled beam systems efficiently use space and energy due to the high heat capacity of heat transfer medium (water). Chilled beam system has long interval and low cost of maintenance because there are no filters to be changed, no drain and no fans. One more advantages of this system is possibility to satisfy simultaneously both individual cooling and heating loads in different rooms using 4-pipe system. Active chilled beams provide better heat comfort compared to induction unit with the same principle of operation due to the location of beams and convection heat-transfer method. Chilled beams have additional integrated options: lighting, sprinkler/fire control systems. Therefore chilled beam systems include all advantages of air-water systems.

But there are also some disadvantages of the chilled beam systems. In the places where heat and contaminant loads are very big during long time the chilled beam systems are less suited. In this case all-air system is more practical. The second problem of system is places with high internal humidity loads or increased risk of infiltration exists. /8./

2.7 Applications

Chilled beam systems are used mostly in the nonresidential buildings. These are commercial buildings, offices, hotels, banks, universities, schools and hospitals.

Chilled beam systems are based on dry cooling principle. Therefore these systems are applied in the premises where humidity of air is controlled by means of dehumidification of primary air and limitation or control of infiltration through the enclosing structures. In other words the building should meet standards of air tightness. Condensation on surface of chilled beam exchanger should be prevented via control of water temperature.

Chilled beam system can be used when total room cooling requirements are less than 80 (max 120) W/floor-m². In that way special attention should be paid to solar radiation, particularly on the south façade. Therefore solar shading should be used to minimize the cooling demand. /2./

3 DESIGNING A SYSTEM WITH CHILLED BEAMS

In this chapter the principle of the chilled beam system design will be discussed. It is described how to create good indoor climate, how to organize the system which would work correctly, how to select the chilled beam, how the beams should be located, how to control the system etc.

In general the design of chilled beam systems can be organized in two steps. First step is determination of the design room conditions. The table 4 shows recommended design values for chilled beam systems. And the second step is the selection of chilled beam type, model, length and decision on other related design parameters. First step is performed in accordance with characteristics of indoor space that will be equipped with chilled beam. But some requirement to the room construction provided by the chilled beam application should be achieved. Typically the design of space and chilled beam selection happen as combined process in order to attain the comfort conditions. After the chilled beam system was approved the control system is selected to guaran-

tee required thermal conditions and energy efficiency work. The figure 1 shows the design methodology of a chilled beam system. /8./

TABLE 4. Minimum water flow rate with different pipe diameter to ensure fully turbulent flow /8, p.15/

	Cooling	Heating
Cooling and Heating		
Optimum heat load/losses	60...80 W/floor-m ²	25...35 W/floor-m ²
Maximum heat load/losses	<120 W/floor-m ²	<50 W/floor-m ²
Specific capacity of passive beam above occupied zone	<150 W/m	-
Specific capacity of passive beam outside occupied zone	<250 W/m	-
Specific capacity of active beams (highest class of indoor climate)	<250 W/m	<150 W/m
Specific capacity of active beams (medium class of indoor climate)	<350 W/m	<150 W/m
Supply air		
Specific primary air flow rate of active beam	5...15 l/s,m	5...15 l/s,m
Supply air temperature	18...20°C	19...21°C
Pressure drop of active beam	30...120 Pa	30...120 Pa
Room air		
Reference air temperature (air into the beam): active beam	Room air temp.	Room air temp. +0...2°C
Reference air temperature (air into the beam): passive beam	Room air temp.+0...2°C	-
Inlet water		
Water flow rate with pipe size of 15 mm (turbulent flow)	>0,03...0,10 kg/s	>0,03...0,10 kg/s
Water flow rate with pipe size of 10 mm (turbulent flow)	>0,015...0,04 kg/s	>0,015...0,04 kg/s
Inlet water temperature	14...18°C	30...45°C
Pressure drop	0,5...15 kPa	0,5...15 kPa

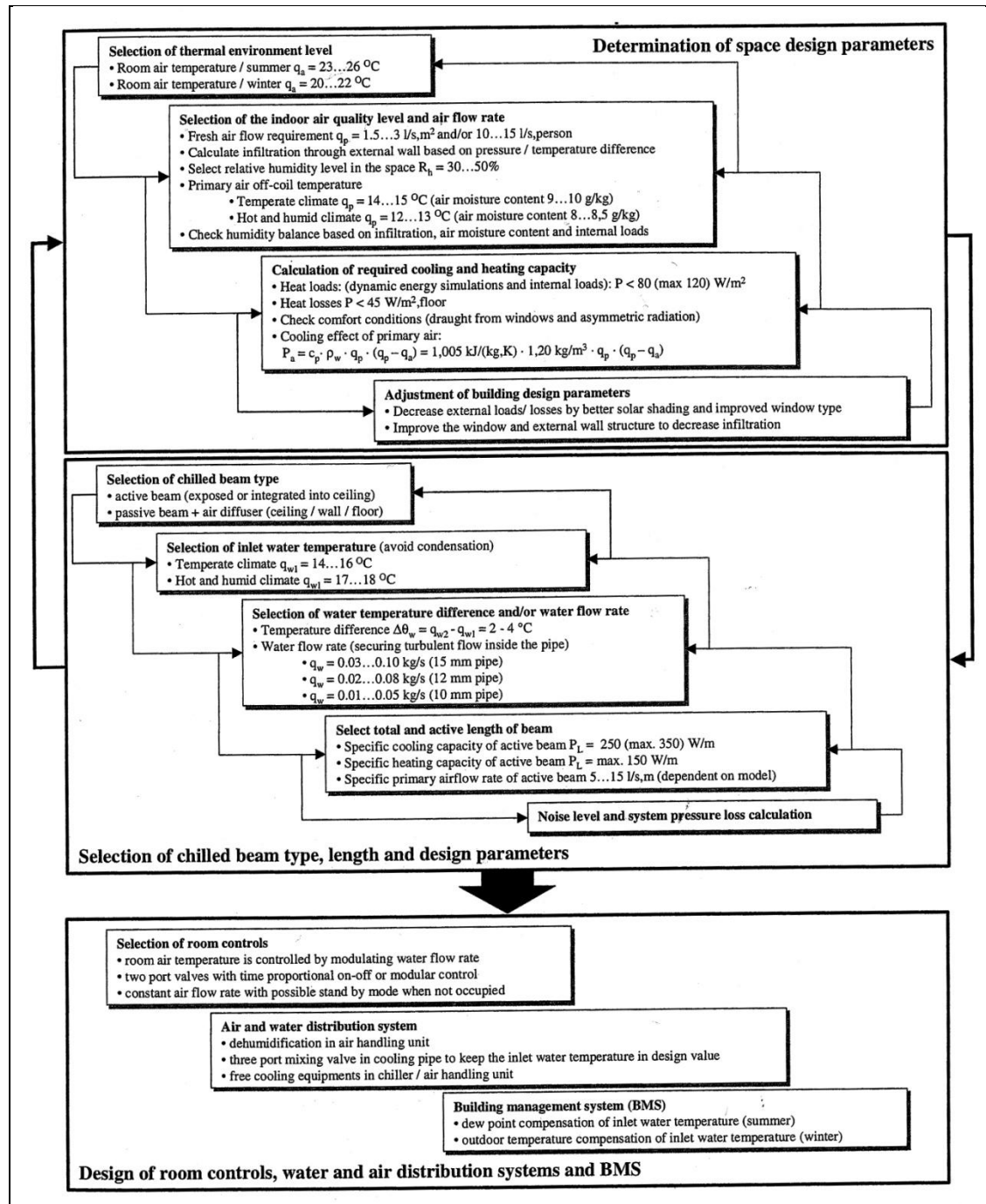

FIGURE 1. Design methodology of a chilled beam system /8, p. 31/

3.1 Operation scheme

The operation scheme of an active chilled beam system is shown in the figure 2. It is typically used in Scandinavia. In this scheme one chiller gives cooling water to the AHU (7 °C) and the chilled beam (15°C).

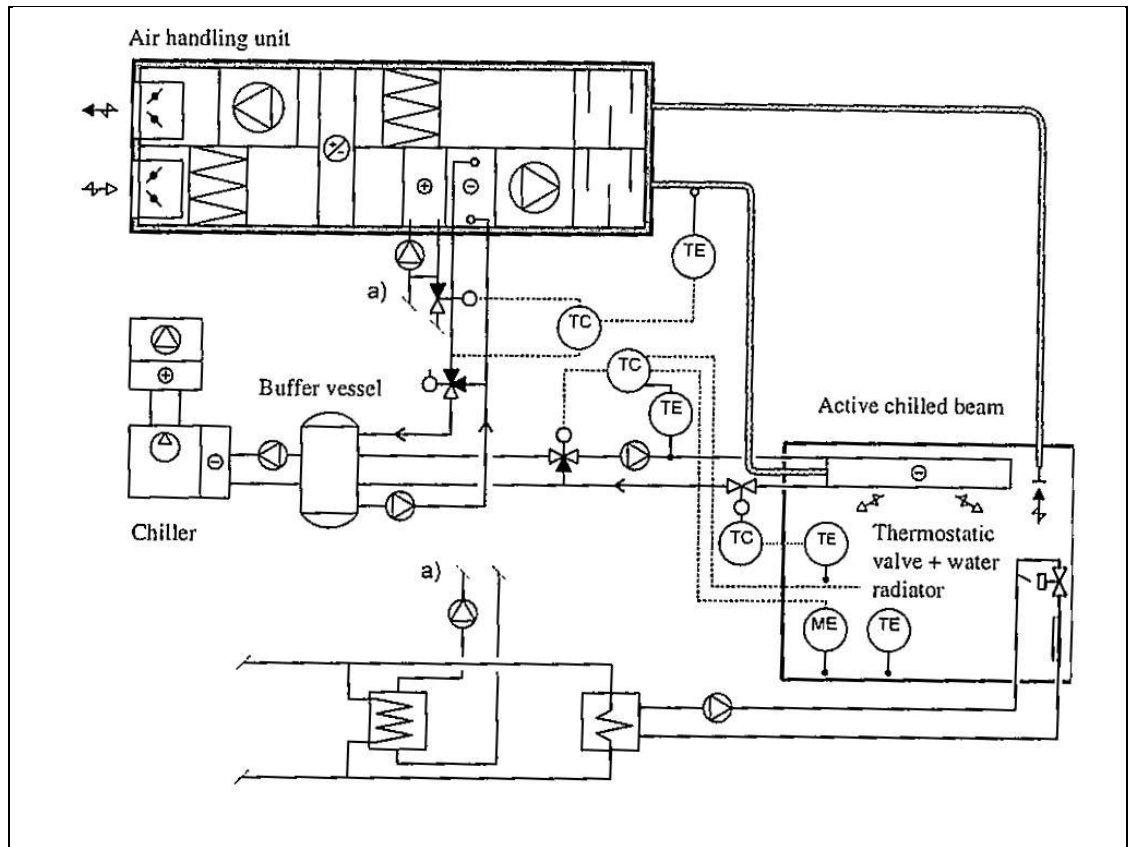

FIGURE 2. Operation scheme /8, p. 27/

3.1.1 Cooling with active chilled beams

The design process starts from the determination of room temperature and the calculation of external sensible heat loads together with internal gains. Also the thermal capacity of the construction should be taken into account in cooling loads calculation. All this is needed to define the cooling capacity requirements of the cooling premise. Overdesign of the system results in the increase of system cost and in reduction of thermal comfort or percentage of satisfied occupants.

Typically the ventilation rate for office room is $1.5\text{-}3 \text{ l/s,m}^2$ ($6\text{-}12 \text{ m}^3/\text{h,m}^2$). The primary air should be dehumidified in order to prevent condensation and to achieve design humidity level. Also the moisture output inside the premise should be taken into account. Chilled beams operate with constant airflow rate. The air temperature depends on the season. For summer time it is $18\text{-}20 \text{ }^\circ\text{C}$ and for winter is $19\text{-}21 \text{ }^\circ\text{C}$. The airflow rate of primary air should be enough to induce secondary air, but not as high to be cause of draught. The normal airflow rate of the active chilled beam is $5\text{-}15$

l/s,m. The inlet temperature of water and water flow rate are chosen so that the required cooling capacity can be achieved. The minimum water flow rate that ensures fully turbulent flow is shown in the table 2 according with different pipe diameter.

The connection method of chilled beam should also be considered. It can be parallel or series. Parallel connection is usually used. But series connection can also be used for short-length or low-capacity premises. The length of chilled beam can also be longer than the actual cooling length to fit into architectural interior. /8./

3.1.2 Heating with active chilled beams

Firstly, the requirements of heating capacity are determined. New office building is requires 30-45 W/m² of heating output that can be provided by active chilled beam. The active chilled beam is designed to work with inlet water temperature 40-45 °C. If the water temperature is higher than normal then the secondary air will be too warm and the operation of chilled beam will not ensure correct work. Comfortable thermal conditions are achieved via the air temperature near the floor being raised because of relatively low temperature gradient. It gives the opportunity to make energy savings by decreasing the short circuit and the exhaust air temperature. Ventilation must be operating in the case of heating by the active chilled beam, because primary airflow rate can determine the heating capacity. /9./

3.1.3 Active chilled beams in hot and humid climates

In these paragraphs the application of active chilled beam in hot and humid climates based on work that was done by Risto Kosonen and Freddie Tan will be discussed. The name of this work is “A feasibility study of a ventilated beam system in the hot and humid climate: a case-study approach”. The experience was done in the Tropical climate in Singapore. The premises were the two rooms of the typical office building where active chilled beams were used. In these conditions the control both of humidity and of the temperature is very important.

The starting point for the system design is the definition of humidity and temperature level. The risk of the condensation can be avoided via minimization of the infiltration

and good control strategy. Therefore the windows, frames and doors should be airtight. The dew point of the indoor air should be less than the inlet water.

The measurements showed that it is possible to prevent condensation and to make dry cooling during working hours. During this research some facts were found. For instance the humidity slightly increases during night time and the dew point change is about 1°C. Also the humidity stays almost constant during the weekend. It means that the air tightness of building construction is on the high level. Attention should be given to the morning time, because during night the humidity is generated. In the mornings the ventilation should be started earlier to decrease the humidity level to the required parameters. And after that the water pump of the active chilled beam system can be switched on. In this case 30 minutes delay was enough. But if the building air tightness is lower then the dehumidification period must be longer and supply air flow should be higher.

Moreover the results have shown that the system with active chilled beam decreases the quantity of handled air and provides high-quality indoor climate. Also the satisfaction of people increases linearly with decreasing enthalpy of the air. The comparison with variable air volume and with fan-coil systems displays that the LC cost of active beam is lower. /3./

3.1.4 Prevention of condensation

The problem of condensation is the most important question in regards of the chilled beam systems. Therefore let's discuss it more carefully. First of all the surface temperature of heat exchanger should be higher than the dew point temperature. In other words the inlet water temperature should be higher than the temperature of condensation. The temperature difference of 1°C is enough. The external influences on the internal humidity should be taken into account if they take place.

The primary supply air is dehumidified by air handling unit therefore to prevent condensation. The cooling coil of the air handling unit should be selected according with periods of high outdoor temperature and high relative humidity level. It means that total cooling capacity including latent and sensible heat load should be achieved. The

internal humidity loads should be absorbed by supply air. The process of dehumidification is shown in the figure 3.

Also the insulation of pipes and valves is recommended to avoid appearance of moisture. Additionally the usage of condensation sensors is a good practice to control condensation. If moisture is found then the cooling water circulation pump should be stopped or control valve should be shut off. As an additional option the openable windows individual contact sensors can be installed. When the window is open the cooling water supply is stopped.

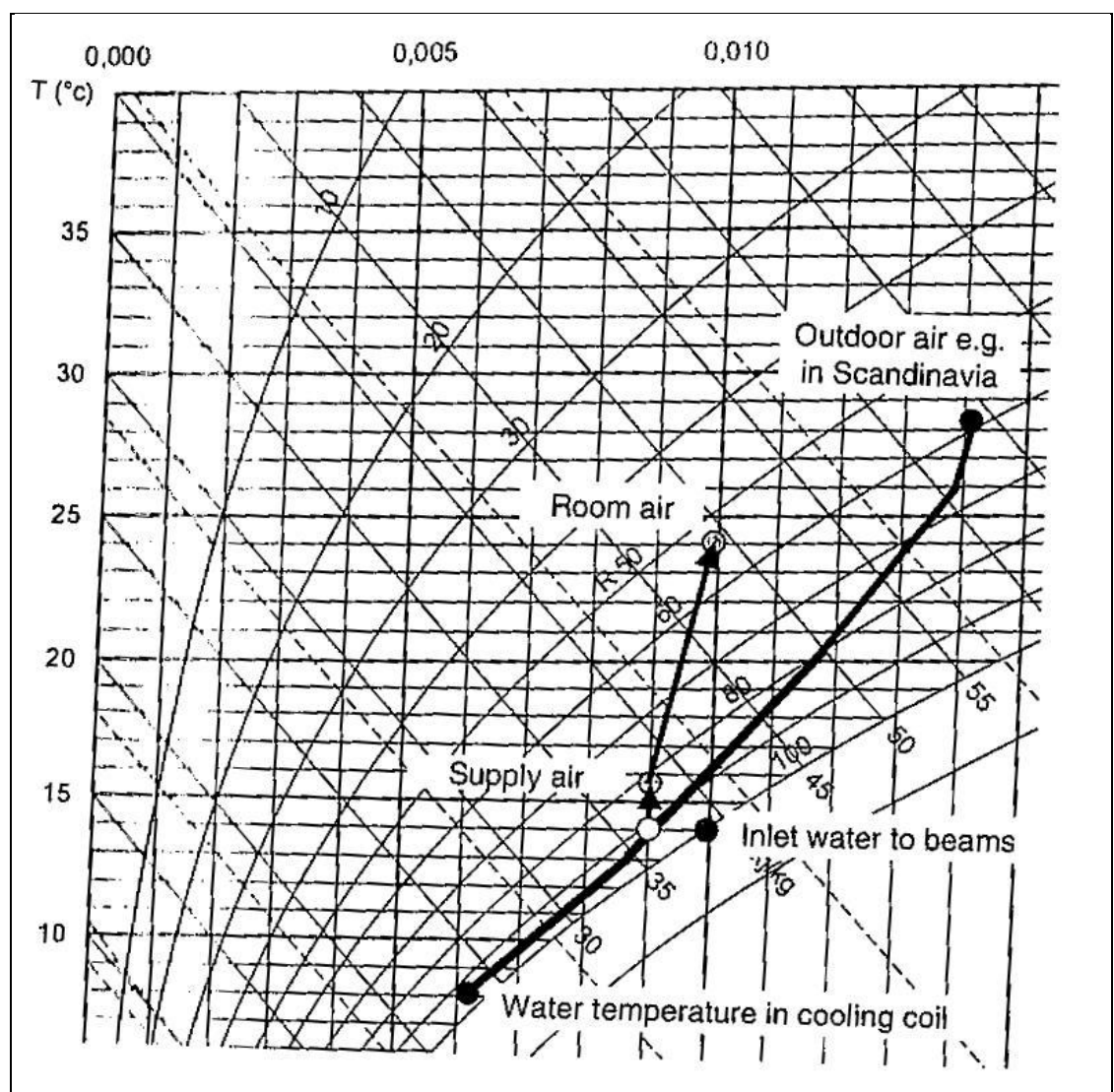

FIGURE 3. Dehumidification process of primary air /8, p. 26/

By practice it is proved that the inlet water temperature can be lower than the dew point in 1.5 °C before the water droplets start to form. This reserve is good safety guarantee. /3./

3.2 Position of chilled beams

The positions of chilled beam should be chosen carefully to guarantee the good thermal conditions in the indoor space. Therefore the possibility of the draught should be taken into account. Also the location of work places, walls, windows and doors has effect. The type of chilled beam (passive or active) determines their position. Let's describe it.

3.2.1 Active chilled beams

Preferred position of active chilled beam is above workplaces. It is because of direction of the air jets which are horizontal. Asymmetrical throw pattern is recommended for the beams located near the wall. The lengthwise installation of active chilled beam is more advantageous. That is associated with the creation of the lowest air velocity and with the lower cooling capacities requirement per linear meter via usage of longer beams. Also the lengthwise installation is better in intermediate season. It is caused by the fact that the window surface is still cold but cooling is already required. Regarding crosswise installation the risk of draught underneath the window increases as the cooling air will be supplied to the cold window surface. Convection flows from the door or windows should be taken into account. Also for the decision on active chilled beam location should be considered distance to the opposite wall and if possible the position of intense heat loads. /6./

3.2.2 Passive chilled beams

The location of passive chilled beam directly above the working place is not recommended. It is related to the air velocity created by natural convection which is highest underneath the beam. Reduction of cooling output is possible if the beam is installed above the window or above other high convective heat loads. To prevent the risk of draught the perforated ceiling can be used. It should be situated under the passive

chilled beam and it should have around 50% of perforations in order to guarantee good cooling and to avoid draught. /7./

3.3 Design requirements to room construction

One of requirements to room construction is to provide the sufficient return air path. Therefore minimum clearance between the top of the beam and soffit should be ensured. The figure 4 shows it.

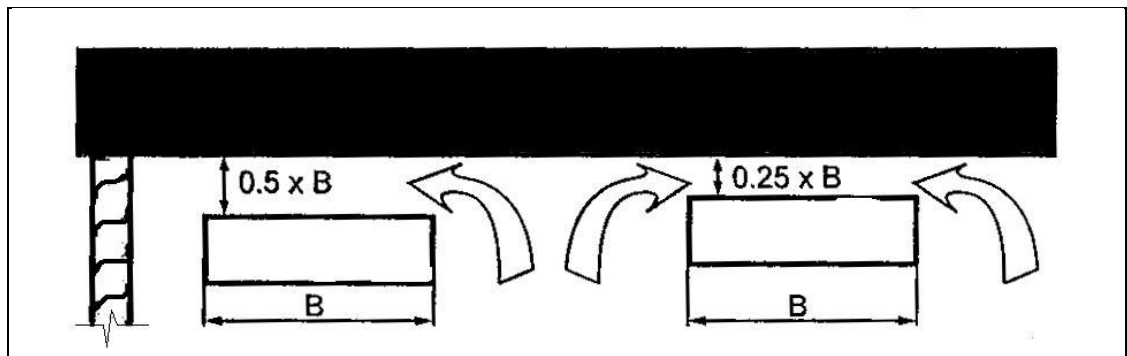

FIGURE 4. The minimum clearance between the top of the beam and soffit /8, p. 16/

Also to provide good return air path the shadow gaps, the dummy beam sections and the transfer grilles should be used. In order to achieve efficient work of chilled beams the return air path should be located at the beam's short side. "The return air path area should be at least 0.1 m^2 per linear active chilled beam meter and minimum 50% of the surface area of passive beams."/8, p.16/

Special attention is given to the window selection for achieving good indoor climate. The transmission coefficient of window should be adequate to National Standards in order to prevent down draught at winter time and direct radiation between the internal window surface and occupants. The average U-value of window is recommended around $1.2 \text{ W/m}^2\text{K}$. Passive chilled beam above the window cannot provide the enough draught reduction. To solve this problem other technical solution should be used, e.g. radiator, electrical heating strips underneath the window or heated window glass. /8./

3.4 System of air and water supply

The system of air conditioning equipped with the chilled beam requires air and water distribution systems. Usually chilled water circuit supplies primary chilled water to the beams through the buffer vessel connected to chiller. And the ducts supply prepared dehumidified air from AHU. Let's describe it more carefully.

3.4.1 Pipes

During design of the pipe network system small difference between indoor air temperature and inlet water flow (around 8-10°C) should be taken into account. In accordance with this the diameters of pipes are larger to provide higher water flow rates. Dimensions of pipes are sized for pressure losses of 50-100 Pa/m therefore to avoid noise generation. For hydraulic calculation of pipe system the maximum recommended pressure is 35kPa. It includes 10 kPa pressure drops in the coil, 10 kPa for the control valve and 10 kPa for the pipe distribution.

The pipes should be insulated to prevent condensation and heat losses. Copper pipes, steel or plastic pipes can be used to connect chilled beam to the distribution system. Plastic pipes can be used without insulation because of the low heat transmission. The location of main pipe should be over the chilled beam in order to prevent air-lock inside the beam.

System with 2-way control valve should have pressure regulation to prevent noise. This can be realized via constant pressure regulators, by-pass connection equipped with a balancing valve or pressure reduction valve at the end of each branch. The by-pass system also controls water temperature in accordance with dew point of indoor air. The figure 5 shows the chilled beam connection. /8./

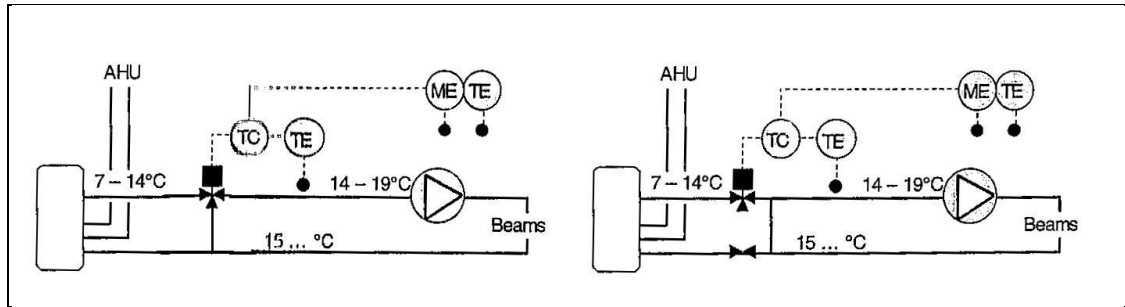

FIGURE 5. The chilled beam connection /8, p. 28/

3.4.2 Ducts

The calculations of chilled beam duct system are similar with calculations for any other ventilation systems. The advantage of dry cooling principle of the chilled beam is the small dimension of ducts due to constant airflow and full outdoor system. The preparation of supply air is provided by air handling unit. The main purpose of AHU is dehumidification of primary air. Due to constant air flow it is possible to avoid individual balancing dampers via the designing of constant pressure ductwork e.g. symmetric branches. Constant pressure controlled ductwork zones are used for the cases when variable flow applications are incorporated in the zone and when effective implementation of airflow adjustment within the zone is required. /8./

3.4.3 Use of free cooling and sustainable heat source

The chilled water temperature is around 14-18 °C. It gives opportunities to use free cooling sources such as outdoor air or ground water heat sink. So high supply water temperature increases free-cooling period. The usage of free cooling technologies reduces the operating cost. But when free cooling sources are used the pumping energy cost should be taken into account. The same situation applies to the heating season. The temperature of heating water is 30-45 °C. Therefore the sustainable heat sources are very useable, especially the heat pumps. Also it depends on high efficiency at the low temperature levels. So the usage of chilled beams presents the possibility to use free cooling and sustainable heat sources. This modern system gives a good way for energy saving. /8./

3.5 Room control

The main parameter that should be controlled is indoor temperature. Usually it is realized by adjusting water flow rates in each chilled beam. Water flow rate is regulated by means of two-way valve. Two-way valve is used in order to minimize pumping cost. Therefore self-action controller or electronic controller is used. The control of room temperature is based on different methods: on/off, time proportional on/off, proportional (P), proportional-integrating (PI). Time proportional on/off or modulating principle is more useful for premises where design and practical cooling demands are different. Combination of room temperature sensor and supply air temperature sensor can ensure perfect vertical room temperature gradient. /2./

The second point that should be controlled is condensation on the surface of chilled beam exchanger. The prevention of the condensation risk is achieved by two ways. It can be a system based on water temperature control via room air dew point calculation for critical zone. Or it can be an electronic dew-point alarm. The dew-point alarm uses sensor in order to register condensation. If this sensor fixes condensation then the chilled water valve will be closed. /1./

3.6 Integrated technical services

Traditional chilled beam is a device for ventilation, cooling and heating. The new construct of chilled beams is all-in-one solution for all types of technical services that are installed in ceiling. Let's describe these integrated services. The most popular is lighting. The integrated luminaires can be direct as well as indirect. Also emergency lights can be built into chilled beam. Different detectors and sensors can be integrated in the chilled beam such as occupancy sensor, daylight sensor and smoke detector. Chilled beam can be equipped with different control devices for the regulation of good indoor climate. It can be done by two-way control valve with actuator and condensation sensor. When it is necessary chilled beam may include room controller and the associated temperature sensor. Also fire extinguisher system is integrated in beam structure. Therefore sprinkler pipes can be installed above the chilled beam and connected to the individual sprinkler nozzles. Additional items are cable shelves for various cables and pre-wired speakers.

The integrated service chilled beams offer following benefits. Integrated service beams are suitable for mounting as in suspended ceiling as well as in exposed installation. Moreover these beams have different styles which are good suited for interior design. Investment cost is more attractive than in the case of traditional chilled beam and suspended ceiling with separate building services. Assembly at the factory increases the productivity of installation work on the site and reduces man-hours and energy consumption. The integrated services chilled beam can be installed without suspended ceiling. That is why headroom can be raised. The use of one device with built-in ceiling technical services minimizes risk and liability in the coordination of those technical systems. /2./

3.7 Selection of chilled beams

Different manufactures with a large variety of chilled beams production are present on the European market. The selection of the most corresponding chilled beams should be based on the following requirements to technical parameters. Technical data can be compared if the measurements were done using the same standards. The main criterion is the cooling capacity. The attention should be given to cooling capacity per meter, heating capacity per meter, supply air flow rate per meter, air chamber pressure and sound level. It is also important to check the following velocities data: maximum air velocity, velocity in occupied zone, velocities in critical points, draught rating. The mode of installation should be taken into account in order to get normal working parameters. Closed beams are used for suspended ceiling and open beams are used for all other cases.

Also materials of chilled beam and dimensions should be taken into consideration. It is important to pay attention to finned coil, pipe and duct connection, the thickness of the fins and fins pitch. Too thin fins can be bended during installation or maintenance. Small distance between fins collects more dust and they are more difficult to clean. The normal fin pitch is 5 mm for active chilled beams and 9 mm for passive chilled beams.

Integrated services, exterior design, color, the total length, access to the coil, access to the damper, access to the valves, difficulty of installation and maintenance, all these have influence on the selection of chilled beam. /7./

3.8 Design software

The worldwide companies present the design software on their web pages. It is Swegon, Flakt Woods, DADANCO etc. These programs help in the chilled beam selection. It suffices to enter the required parameters and the program will calculate the necessary chilled beam. All selection programs are free and easy in use. Usually all programs go with manuals. Also the program AutoCAD by Autodesk Company already gives the possibility to design systems with chilled beams.

4 INSTALLATION AND COMMISSIONING

There are some requirements to installation and commissioning of the chilled beam. As it was described earlier the chilled beam can be mounted fully exposed, in the suspended ceiling or above perforated ceiling. Anyway the access to the beam service should be provided. When chilled beams are installed with suspended ceiling the beams should be at one level with ceiling or lower in order to prevent incorrectly air supply. The beam can be installed directly to the ceiling or with threaded drop rods. The weight of the beam is 10-20 kg/m.

For proper pipe work the main pipes should be installed above the chilled beam connection to prevent the generation of "air pocket". The venting valves should be installed at all highest points of the system. The pipes are connected with beams via crimp, screw, solder connection or with flexible hoses. The air diffusion resistant hoses are recommended. The pipe connection to the beam should be done carefully with special attention to avoid bend and break of the heat exchanger joints. Also the coupling rings should be used. The distance between the balancing damper and the chilled beam should be in accordance with design requirements in order to prevent the air swirl. Otherwise it can produce noise and incorrect work of air nozzles.

The flushing process is started from the main pipe with closed shut-off valves of the beams. For filling-up the system all valves must be fully opened and pumps must be stopped. The filling is a static process. The venting of the system should be continuous. It is recommended to use manual and automatic venting valves. When the water system is full then the pump should be started to vent all air. Therefore the system should be cut at small circuits in order for water to circulate fast. The parts of system are vented one after another.

During the commissioning the water and air flow rates are adjusted. The design air-flow rates are achieved by blade or an iris damper. The usage of chamber pressure measurement is recommended in the beam. This method gives the most accurate result. The water system is balanced by balancing valves. The control valves are used to control the water flow rate of chilled beam. /1./

5 OPERATION AND MAINTENANCE

The operation and maintenance of chilled beam system is very simple. The system should be equipped with access doors. The access should be to the valves, dumpers, heat exchanger and supply air plenum for cleaning, service and maintenance. The vacuum cleaning of heat exchanger should be performed every 5 years and more often if needed. The finned coil must be always dry. If fin surface is wet then the dirt will be easy to adhere. As there is no moving parts like fan, no filters, no drain system so the maintenance is trouble free. /6. /

For good operation of the chilled beam system the following points are important. The inlet water temperature must always be above dew point. If the condensation happens for any reason the water flow should be stopped and the problem should be solved. To prevent the high humidity level the circulation of water should be stopped and ventilation should work to dehumidify the air. The 3-way mixing valves should be in the working conditions. These were the basic items of chilled beam operation for achieving the excellent thermal comfort.

6 THE MANUFACTURERS AND SUPPLIERS

Chilled beam systems are mostly widespread in Europe. Scandinavian countries have a leadership on this market since they pay a lot attention to the thermal comfort. The largest attention to indoor environment quality is given in Finland. In this country the most innovative chilled beam companies are founded. There worldwide company Halton is based. The production facilities of Halton Group are located in Finland, France, Germany, Hungary, UK, USA, Canada, China and Malaysia. Flakt Woods is a Swedish company which is also very popular. Flakt Woods employs in 30 countries. The other big company which provides chilled beam technology is Swegon.

The second manufacturing center of chilled beam technology is located in America. Among American companies very well known is Trane. There is also some other companies in the world: Frenger Systems (UK), Trox Technik (Germany), DADANCO (Australia), SAS International (UK) etc.

7 CONCLUSION

The chilled beam is a very efficient system. It has some advantages over the other air-water systems and over all-air VAV systems that were described in my thesis. The active chilled beams can remove large amounts of sensible heat and at the same time this system reduces primary air flow requirement. The maintenance of the chilled beams is trouble-free. Also integrated services can be used. The lifecycle cost of chilled beam system is lower than in other cooling systems. Also the energy consumption of beam system is low. The asset of chilled beam system is the usage of free-cooling and sustainable heat source.

The research describes the chilled beam system and its characteristics. We obtained a clear picture of chilled beams application, operation ranges, principle of operation and other specific items. Also the design process, operation schemes, requirements to room construction, selection process, control system were taken to piece and analyzed. This research is aimed to become an introductory text for Russian HVAC designers. In addition this thesis reviews installation, commissioning, operation and maintenance of the chilled beam system. Surprisingly the study-case has shown that the application

of chilled beam systems in hot and humid climates is possible. To implement chilled beam systems in such challenging conditions minor modification of the automatic system of chilled beams should be done.

The research has shown that the chilled beam system is very useful to provide excellent working environment that has a good effect on the health of people and their productivity. These systems efficiently work in any administrative buildings. In my opinion Russian designers should give more attention to the chilled beam technology.

BIBLIOGRAPHY

- 1) **Flakt Woods 2008.** Project design guide-Chilled beams.
- 2) **Halton Oy 2007.** Chilled Beam Design Guide.
- 3) **Kosonen R., 2003.** A Feasibility Study of a Ventilated Beam System in the Hot and Humid Climate: A Case-Study Approach.
- 4) **Loudermilk, Ken 2009.** Designing Chilled Beams for Thermal Comfort. ASHRAE Journal. p. 58-64.
- 5) **Ministry of the Environment Housing and Building Department 2003.** D2. Indoor Climate and Ventilation of Buildings. Regulations and Guidelines.
- 6) **Swegon Oy 2007.** System technology.
- 7) **TROX technik 2009.** Chilled Beam Design Guide.
- 8) **Virta, Maija 2004.** Chilled Beam Application Guide Book. Rehva.
- 9) **Virta, Maija 2008.** Chilled beam systems in heating mode. IRHACE. p. 20-21.