

**Calculation and study of variable connections for precast  
concrete wall against shear forces in different load categories  
and consequence classes**



Bachelor's thesis

Hämeenlinna University Centre

Degree Programme in Construction Engineering

Spring 2020

Hoang Anh Tran

Degree Programme in Construction Engineering  
Hämeenlinna University Centre

---

<b>Author</b>	Hoang Anh Tran	<b>Year</b> 2020
<b>Subject</b>	Calculation and study of variable connections for precast concrete wall against shear forces in different load categories and consequence classes	
<b>Supervisor(s)</b>	Arnee Henson (AFRY Finland) Tomi Karppinen (HÄME University of Applied Sciences)	

---

ABSTRACT

This Bachelor's thesis was commissioned by AFRY Finland Oy. The purpose of the thesis was to study variations of connection against shear forces in precast concrete wall elements. The thesis concentrated on three loading cases according to different consequences classes, CC2a, CC2b, and CC3a-b. Following up these consequence classes, designing tie or connection types and calculating tie forces were studied.

An example of office building was presented and analysed. In this example project, vertical shear was calculated and a suitable connection was chosen. As a result, the modelling technique or setting for connection was indicated in Tekla Structures. These settings in Tekla can be used as a reference in the company in future projects. In addition, the best practice or working solutions were provided based on site comments and design efficiency.

**Keywords** Connection details, reinforcement, geometry, wire loops, TS-joint, precast concrete wall element, consequence classes, Robot Structural Analysis, Tekla Structures

**Pages** 75 pages including appendices 18 pages

# CONTENTS

1	INTRODUCTION .....	1
1.1	Background and motivation .....	1
1.2	Objectives .....	1
1.3	Organisation of the thesis .....	1
2	LOADS ON SHEAR WALL ELEMENT .....	2
2.1	Shear wall .....	2
2.2	Horizontal loads .....	4
2.2.1	Wind load .....	4
2.2.2	Geometric Imperfection.....	5
2.3	Vertical loads .....	6
2.4	Consequences classes of the building and accidental load cases .....	6
2.4.1	Consequence class CC1 .....	8
2.4.2	Consequence class CC2a .....	8
2.4.3	Consequence class CC2b .....	8
2.4.4	Consequence class CC3 (CC3a and CC3b) .....	8
3	SHEAR JOINTS IN PRECAST WALL ELEMENTS .....	9
3.1	Function of joint or tie.....	9
3.1.1	Peripheral and internal ties.....	10
3.1.2	Horizontal ties to columns and walls.....	11
3.1.3	Vertical ties.....	12
3.2	Transfer of shear force in concrete construction .....	12
3.2.1	Shear at the interface between concrete cast at different time .....	12
3.2.2	Principle of shear force transfer .....	14
3.2.3	Vertical shear joints of wall elements.....	17
3.3	Vertical Shear joints of wall panels with loop connection .....	18
3.3.1	U-bar connections.....	20
3.3.2	Wire loops connection .....	22
4	CASE STUDIES.....	28
4.1	Procedure for determining consequences classes .....	28
4.2	General information.....	30
4.3	ROBOT Structural Analysis.....	32
4.3.1	General loads.....	33
4.3.2	Wind loads.....	34
4.3.3	Geometric imperfection.....	35
4.3.4	Results .....	37
4.3.5	Accidental case .....	40
5	TEKLA MODELING .....	40
5.1	Manufacturer's recommendation .....	40
5.2	Reference project.....	43

6	ON-SITE COMMENTS AND EXPERIENCE .....	48
6.1	Wire Loops Connection .....	48
6.2	Heavy duty joint .....	52
7	CONCLUSION .....	54
	REFERENCES.....	56

Appendices

Appendix 1 Accidental case calculation

Appendix 2 Typical wall element connections

# 1 INTRODUCTION

## 1.1 Background and motivation

Precast concrete structures are widely used currently. It is undeniable that they provide a timesaving, cost effective construction process and a better possibility to control the quality, compared to in-situ cast concrete structures. However, one of the difficulties rising in precast concrete structures is the matter of well-performing connections between precast elements. These connections act as the most important role in ensuring strong structural behaviour of the connection such as simple, semi-rigid or rigid connections. Different from cast in-situ concrete structures which all the reinforcement and concrete cast are flexibly accomplished on site, in order to ensure continuity and load transfer between the precast elements, the connections for precast elements are usually demanded to be established in narrow zones. (Jørgensen, 2014, p. 1)

Understanding the difficulty, a study for the various connections solution was carried out according to the Eurocode and National building code of Finland. This thesis only studies concrete wall element connection regarding shear joints.

## 1.2 Objectives

The objective of the thesis is to study the variation of connections in concrete wall elements against consequence classes. These connections were U-bar loop and wire loop. To accomplish this thesis, on-site experience and theoretical calculation study were performed. The aim was to study and summarize the variation of connections that can be used for shear resistance of wall in different loading situations. Moreover, the seam reinforcement was taken into consideration to support the full connection between wall elements.

## 1.3 Organisation of the thesis

The thesis is organized into two main parts. Part one gives information about concrete wall panel, function of joints, different consequence classes and how loads are transmitted through the wall elements when they have been formed as simple, semi-rigid or rigid components. Part two is about ROBOT calculation and modelling or setting the connection between pre-cast wall elements in Tekla Structures, especially for shear connection. Three types of loads acting on wall were studied, i.e. normal, semi-heavy and heavy case according to different consequence class, CC2a-CC3b, defined in Eurocode and National building code of Finland. A variation of connection and seam connection are made with U-bars and wire loops.

## 2 LOADS ON SHEAR WALL ELEMENT

### 2.1 Shear wall

A shear wall is a structural panel that resists lateral loads which are parallel to the plane of the wall, especially wind and seismic loads. Shear wall plays an important role in large, high-rise buildings, or buildings in high wind and seismic activity area. Shear walls can be placed at the perimeter of the buildings. They may also form a shear core, a lift shaft or a stairwell for example. The role of shear walls is to act as vertical cantilevers in order to transfer the horizontal loads to the structural foundations (Bill, John, & Ray, 2007, p. 48)

The shear wall can act as stabilising system to resist horizontal loads in its own plane. The wall behaves as one structural unit made of interacting wall elements. This structural interaction needs to be secured by structural connections which can resist the demanded shear forces, tensile forces and compressive forces according to Figure 1 below

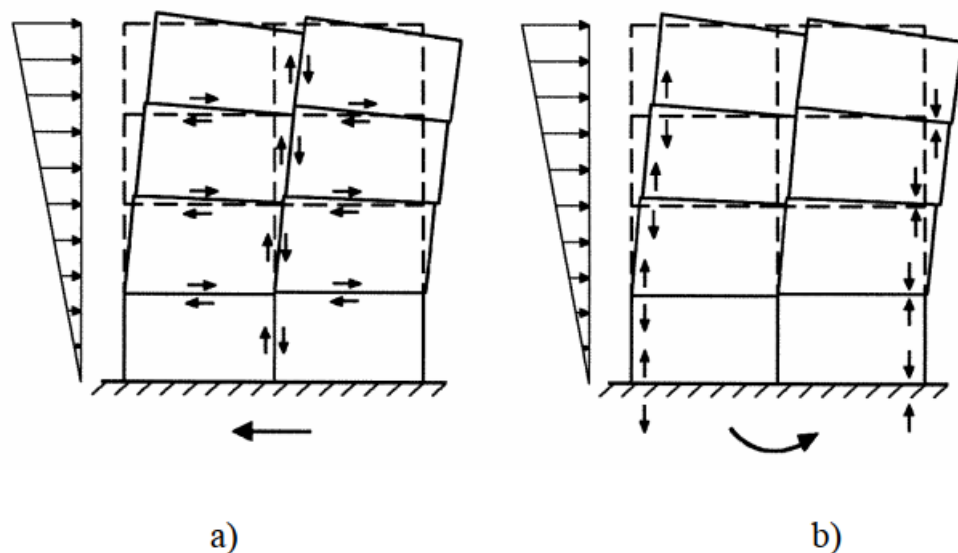

Figure 1 In-plane action of precast wall, a) shear force, b) compressive and tensile force (CEB-FIB, 2008, p. 8)

If there is a nominal stiffness in wall joints or slab joints, the wall or slab structure will act as a series of beams. In such a way, there will be a smaller load carrying capacity than homogeneous structures. Moreover, when the joints are stiffer, the series of shear walls will become more homogeneous. An internal moment and shear force in walls are created by a horizontal load which also induces normal and shear stresses in the vertical and horizontal sections. (BCA, 2001, p. 20)

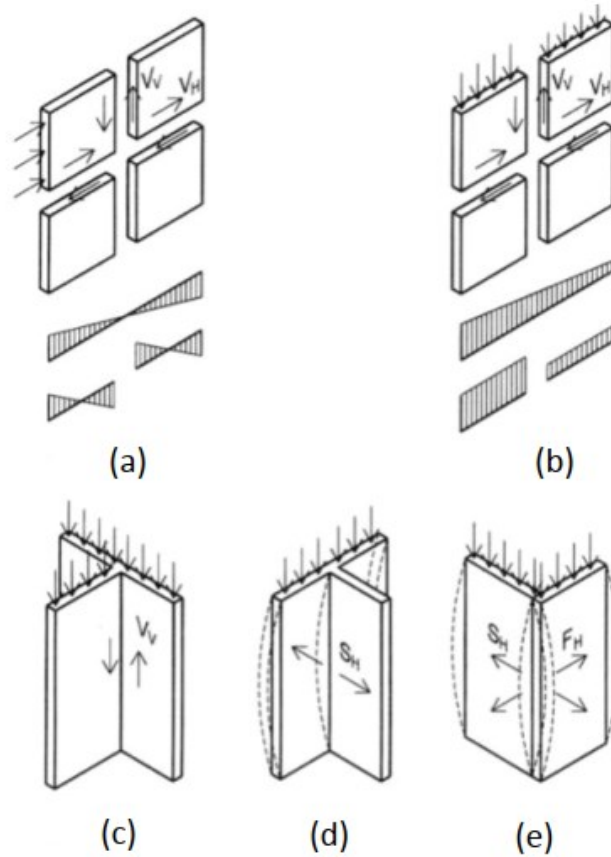

Figure 2 Shear and normal stresses distribute on shear wall (BCA, 2001, p. 21)

If the components interact, the horizontal load transfers to horizontal and vertical shear joint, as shown in Figure 2(a). Figure 2(b) shows that the action of vertical load is different from one wall to other, which will result in shear forces at adjoining connections. This depends on the span of the walls. In Figure 2(c), the vertical joint between the two walls has to resist shear force which is formed by vertical loads. Stirrups and locking bars have to be installed in order to prevent possible horizontal wall deflections, according to Figure 2(d). In the last figure, Figure 2(e) indicates that the vertical joint must be locked in order to avoid the risk of horizontal wall deflection. (BCA, 2001, p. 21)

In the case of non-uniform vertical load acting on wall, there will be uniformly distributed vertical stresses in the next horizontal joint which is shown in Figure 3 below. Shear force in wall to wall connections will be induced. (BCA, 2001, p. 21)

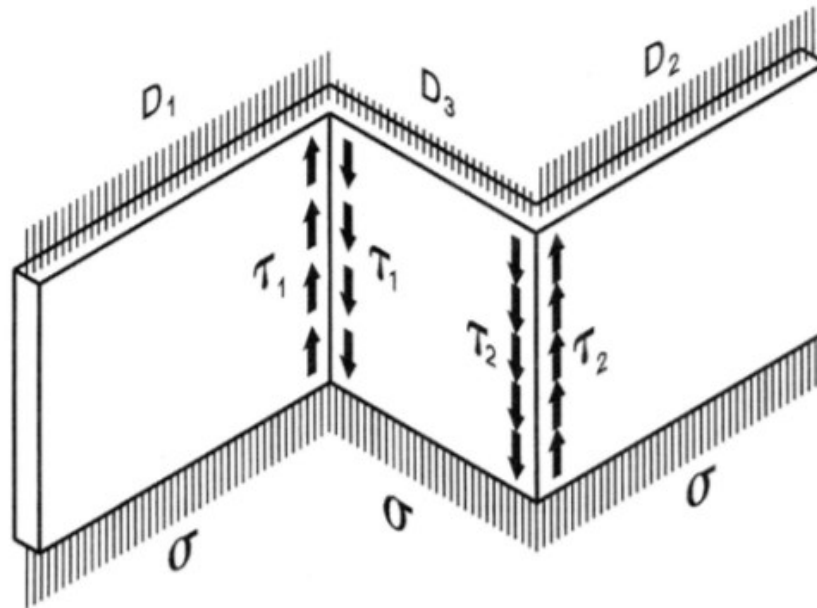

Figure 3 Normal and shear stresses in wall created by non-uniform vertical load (BCA, 2001, p. 21)

The shear wall can be considered as homogeneous when the horizontal load on the structure is increased at the point where the limiting shear stress is reached in the joint. Up to this load, according to the theory of plasticity, the horizontal bearing capacity is also assumed to be fully utilised. (BCA, 2001, p. 21)

## 2.2 Horizontal loads

### 2.2.1 Wind load

Among different types of horizontal loads, the wind actions have the most impact on structure. According to Eurocode, the influence of wind on structure relies on the dynamic properties, shape and size of the structure. (SFS-EN 1991-1-4, 2005, p. 17)

Wind actions change irregularly by time and act as pressures directly on the outer surfaces of the enclosed structure and indirectly on the inner surfaces. When it comes to open structures, wind actions now act directly on the internal surface. Pressures that act on the areas of the surface will create forces normal to the structural surface or of the individual cladding components. When wind load acts on the large areas of structures, there may be significant friction forces acting tangentially to the surface. If nothing else is specified, the wind actions are considered as variable fixed load. (SFS-EN 1991-1-4, 2005, p. 17)

To understand the wind action on structure, the set of pressures or forces are simplified. The effects of these pressures and forces are similar to the extreme effects of the turbulent wind.

The velocity of the wind pressure is various depending on the terrain height, roughness and orography. Also, large and considerably higher neighbouring structures and closely spaced buildings or other obstacles also play the important role on defining mean wind.

The net pressure on the roof, wall or elements is different between the pressures on the opposed surfaces with considered signs. Pressure that is directed towards the surface is assumed to be positive. The pressure directed away from the surface is taken as negative.

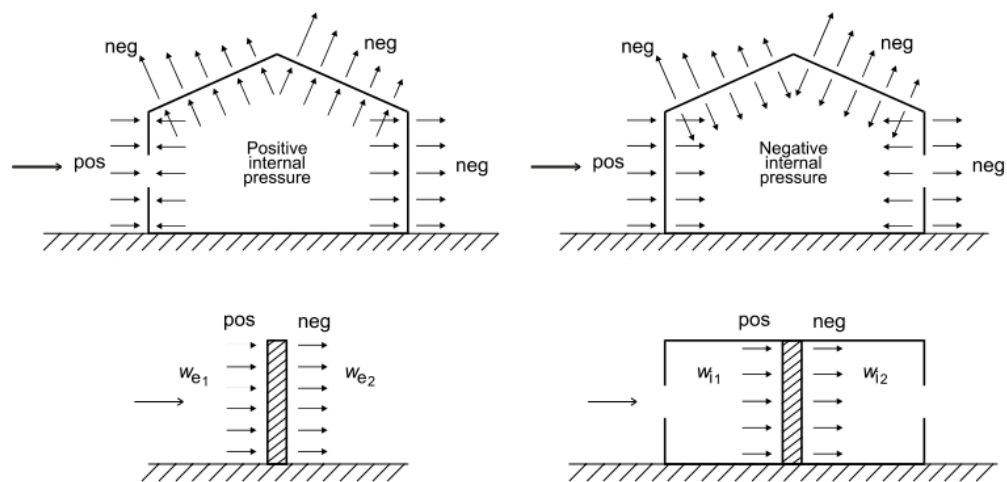

Figure 4 Wind pressure on surfaces (SFS-EN 1991-1-4, 2005, p. 25)

When the total area of all surfaces parallel with the wind is equivalent or less than 4 times the sum of area in all external surfaces perpendicular to the wind, the effects of wind friction on the surface can be disregarded. In the sum of the wind forces acting on the structure, the lack of correlation of wind pressures between the windward and leeward sides is considered. (SFS-EN 1991-1-4, 2005, pp. 19-25)

### 2.2.2 Geometric Imperfection

In the analysis of members and structures, the unfavourable effects of deviations in the geometry of structure and the loading position are considered. Imperfections are taken into consideration in ultimate limit states in persistent and accidental design situations.

Horizontal loads due to such geometric imperfection are calculated according to the method given in Eurocode 1992-1-1, 2004, pp. 54-56.

Figure 5 below shows the effect of geometric imperfections.

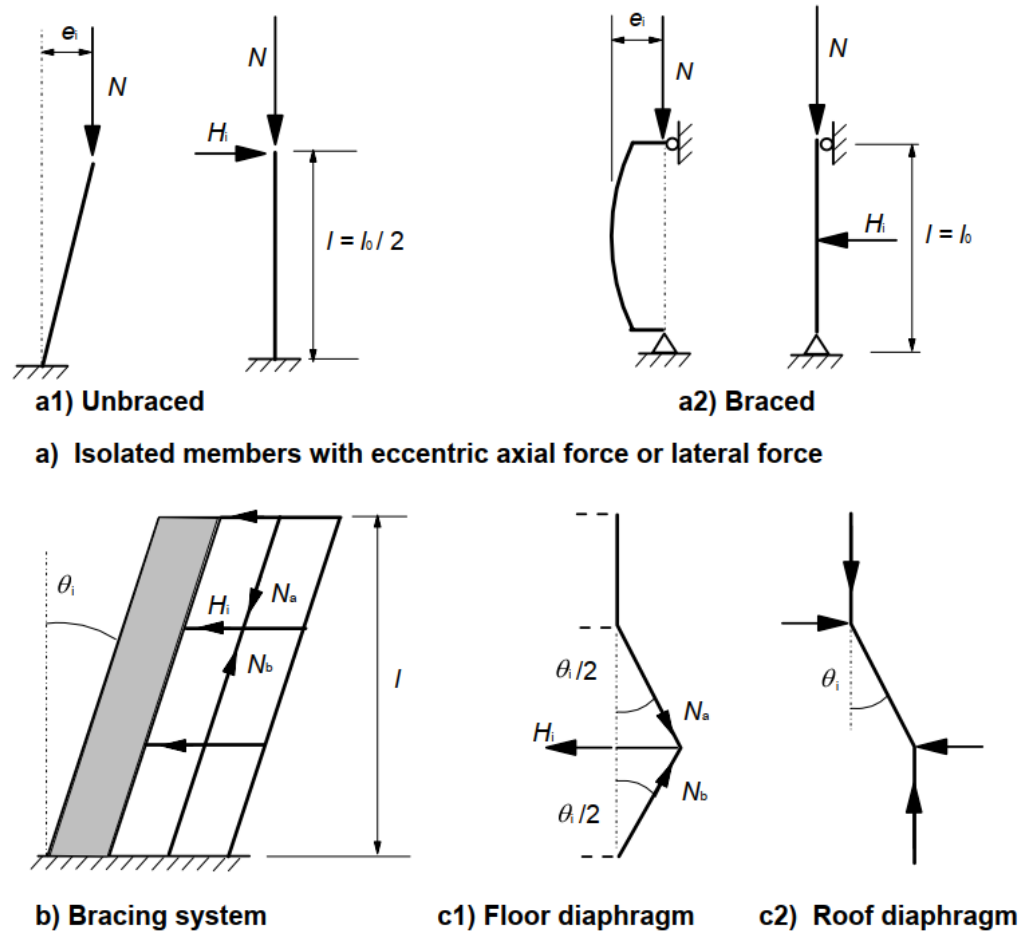

Figure 5 The effect of the geometric imperfections (SFS-EN 1992-1-1, 2004, p. 56)

### 2.3 Vertical loads

The vertical actions on a structure include snow loads, imposed loads and dead loads. The vertical actions are combined for each floor and transferred by the bearing components of the structure. Vertical load also affects the geometric imperfection and the stiffness of the building.

### 2.4 Consequences classes of the building and accidental load cases

The designing of a building strategy is acceptable when neither the whole building nor an individual part of it will collapse in case that localised failure was sustained. This strategy should provide a building with the sufficient robustness in order to withstand a reasonable range of unexpected accidental actions.

Consequence classes can be defined as shown in Table 1 below when considering the different cases of failure or malfunction of the structure.

Table 1 Definition of consequences classes (SFS-EN 1990, 2002, p. 58)

Consequences Class	Description	Examples of buildings and civil engineering works
CC3	<b>High</b> consequence for loss of human life, <i>or</i> economic, social or environmental consequences <b>very great</b>	Grandstands, public buildings where consequences of failure are high (e.g. a concert hall)
CC2	<b>Medium</b> consequence for loss of human life, economic, social or environmental consequences <b>considerable</b>	Residential and office buildings, public buildings where consequences of failure are medium (e.g. an office building)
CC1	<b>Low</b> consequence for loss of human life, <i>and</i> economic, social or environmental consequences <b>small or negligible</b>	Agricultural buildings where people do not normally enter (e.g. storage buildings), greenhouses

Along with three consequences classes, the building types and occupancies are pointed out with specific descriptions in the following categorisation. The categorisation shows the low, medium and high consequences classes. (SFS-EN 1991-1-7, 2006, p. 34)

Table 2 Categorisation of consequences classes

Consequence class	Example of categorisation of building type and occupancy
1	Single occupancy houses not exceeding 4 storeys. Agricultural buildings. Buildings into which people rarely go, provided no part of the building is closer to another building, or area where people do go, than a distance of 1½ times the building height.
2a Lower Risk Group	5 storey single occupancy houses. Hotels not exceeding 4 storeys. Flats, apartments and other residential buildings not exceeding 4 storeys. Offices not exceeding 4 storeys. Industrial buildings not exceeding 3 storeys. Retailing premises not exceeding 3 storeys of less than 1 000 m <sup>2</sup> floor area in each storey. Single storey educational buildings All buildings not exceeding two storeys to which the public are admitted and which contain floor areas not exceeding 2000 m <sup>2</sup> at each storey.
2b Upper Risk Group	Hotels, flats, apartments and other residential buildings greater than 4 storeys but not exceeding 15 storeys. Educational buildings greater than single storey but not exceeding 15 storeys. Retailing premises greater than 3 storeys but not exceeding 15 storeys. Hospitals not exceeding 3 storeys. Offices greater than 4 storeys but not exceeding 15 storeys. All buildings to which the public are admitted and which contain floor areas exceeding 2000 m <sup>2</sup> but not exceeding 5000 m <sup>2</sup> at each storey. Car parking not exceeding 6 storeys.
3	All buildings defined above as Class 2 Lower and Upper Consequences Class that exceed the limits on area and number of storeys. All buildings to which members of the public are admitted in significant numbers. Stadia accommodating more than 5 000 spectators Buildings containing hazardous substances and /or processes

According to National Building Code of Finland, consequence class CC3 will be divided into CC3a and CC3b. Consequence class CC3a includes residential buildings, office buildings, commercial buildings with 9–15 storeys and other buildings with 9–15 storeys that have a similar intended use and load bearing system. Basement storeys are also regarded as the number of storeys. Consequence class CC3b includes other buildings with more than 8 storeys, concert halls, theatres, sports and exhibitions halls and spectator galleries. Heavily loaded buildings or buildings with large spans that are often occupied by a large number of

people and special structures according to a case-by-case assessment will also be included in this class. (Ministry of the Environment, 2016, pp. 39-41)

According to Eurocode and National Building Code of Finland, the following recommended strategies should provide an acceptable level of robustness.

#### 2.4.1 Consequence class CC1

For consequences class CC1, there is no specific consideration regarding accidental actions from unidentified reason. (SFS-EN 1991-1-7, 2006, p. 34)

#### 2.4.2 Consequence class CC2a

In the addition to the operating principles related to consequences class CC1, horizontal ties for framed or effective anchorage of suspended floors to load-bearing walls should be provided for the consequence class CC2a. (SFS-EN 1991-1-7, 2006, p. 35)

#### 2.4.3 Consequence class CC2b

When it comes to consequence class CC2b, in addition to recommended strategies for consequence class CC1, horizontal ties shall be used in horizontal structures and vertical ties shall be used in every load bearing columns and walls. (SFS-EN 1991-1-7, 2006, p. 35)

Alternatively, the vertical structures shall be bound to horizontal structures. In this consequence class, another important matter is that the building needs to be checked to make sure that when notionally removing each supporting column and each beam supporting a column, or any section of load-bearing wall which is defined in SFS-EN 1991-1-7, section A.7, the building stays stable and local damage does not exceed an acceptable limit. (SFS-EN 1991-1-7, 2006, p. 35)

In the case where the notional removal of the columns and sections of walls is made by an extent of damage that overreaches the agreed limit, such elements must be designed as a "key element". (SFS-EN 1991-1-7, 2006, p. 35)

#### 2.4.4 Consequence class CC3 (CC3a and CC3b)

For consequence class CC3, a systematic risk assessment must be taken into account in both foreseeable and unforeseeable consequence cases.

In National Building Code of Finland, for consequence classes CC3a and CC3b, the recommended strategies are the same as consequence class CC2b.

Those parts of the building in which the notional removal of a column or a load-bearing wall section makes a horizontal structure with horizontal ties act as an overhang shall also be inspected. (Ministry of the Environment, 2016, p. 41)

All the tie systems used in various consequence classes will be discussed in the following section, "Shear joints in precast wall elements". The method and consequence class definition will be summarized in section 4.1.

### **3 SHEAR JOINTS IN PRECAST WALL ELEMENTS**

#### **3.1 Function of joint or tie**

According to SFS-EN 1992-1-1 2004, a suitable tying system is needed in structures which are not designed to withstand unpredictable accidental actions. This will provide alternative load paths after load damage to prevent progressive collapse. In order to satisfy this requirement, a prefabricated building must be equipped with peripheral ties, internal ties, horizontal column or wall ties, and if necessary, vertical ties, particularly in panel buildings. If a building is divided into structurally independent sections by expansion joints, an independent tying system is needed in each section. The reinforcement joints must guarantee to act at its characteristic strength and be capable of carrying tensile forces. Moreover, the reinforcement used for other purposes in columns, walls, beams and floors may help to provide part of or the whole of these ties.

Figure 6 shows the tying system.

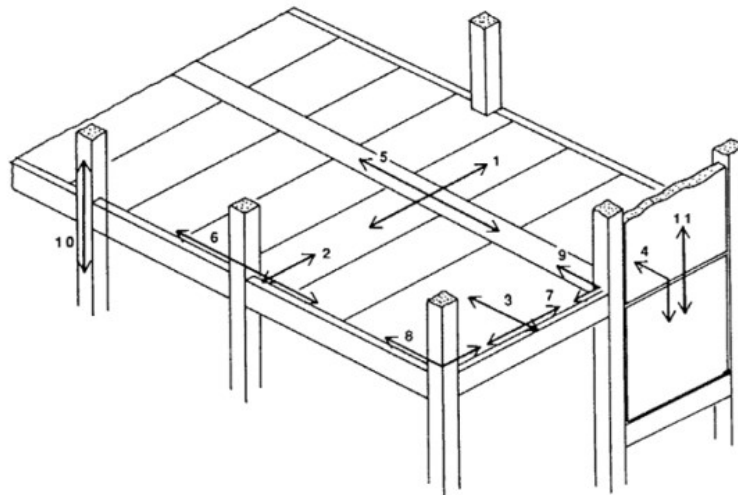

Figure 6 Tying system (Betoinormikortti 23, 2012, p. 19)

The design of joints is based on the stresses and forces between the elements and the geometry of the structure. The joints must withstand all loads and the resulting stresses that the joints are likely to be exposed to during the construction and normal operation of the building. The stress between the elements is caused by permanent and variable, temperature changes, force constraints, eccentricities and skewness of the structure. In addition to these, the dimensioning of the joints should also take into account the accident loads. (Liitosten toiminta, N.d)

The joints are designed so that the compressive forces caused by the vertical loads are completely transferred through concrete structures to the foundation and into the ground. The horizontal forces, in turn, are transmitted through the connecting parts from the structural part to the other and finally through the foundations to the ground. The horizontal forces are usually taken either as a pulling force on the slabs parallel to the plane of the slab or as vertical shear force. (Liitosten toiminta, N.d)

### 3.1.1 Peripheral and internal ties

Peripheral and internal ties should be needed around the perimeter of each floor and roof level and inside the two right angle direction. They should be continued and placed closely as possible to the edges of floors and lines of columns and walls. The peripheral and internal ties in different consequence classes are not discussed in this thesis, regarding precast wall elements connection. (Ministry of the Environment, 2016, p. 41)

### 3.1.2 Horizontal ties to columns and walls

It is recommended that edge columns and walls should be tied to every floor and roof. Such tie forces follow the characteristic value of the permanent action  $g_k$  for the horizontal structure. The ties must have ability to sustain the following forces in accidental limit state according to different consequences classes.

In consequences classes CC2a and CC2b, the tie force will follow these formulas. (Ministry of the Environment, 2016, p. 45)

$$\begin{cases} F_{tie} = 20 \frac{kN}{m} \cdot s, & \text{when } g_k \geq 3.0 \text{ kN/m}^2 \\ F_{tie} = 3 \frac{kN}{m} \cdot s, & \text{when } g_k \leq 2.0 \text{ kN/m}^2 \\ F_{tie} \leq 150kN \end{cases}$$

Where:

$g_k$  is the characteristic value of the permanent action for the horizontal structure

$s$  is the calculation width of the tie force;  $s$  is measured according to figure 7.

In consequences classes CC3a and CC3b, the tie force is calculated as the following formula (Ministry of the Environment, 2016, p. 45)

$$\begin{cases} F_{tie} = F_t \cdot \frac{h}{2,5m} \cdot s \\ F_{tie} \leq 2 \cdot F_t \cdot s \end{cases}$$

Where,

$$F_t = \min \left\{ \begin{array}{l} 48kN/m \\ (16 + 2,1 \cdot n_s)kN/m \end{array} \right.$$

$h$  is the storey height;  $s$  is the calculated width of the tie force and  $n_s$  is the number of storeys.

The width of the tie force,  $s$  is calculated like the following example.

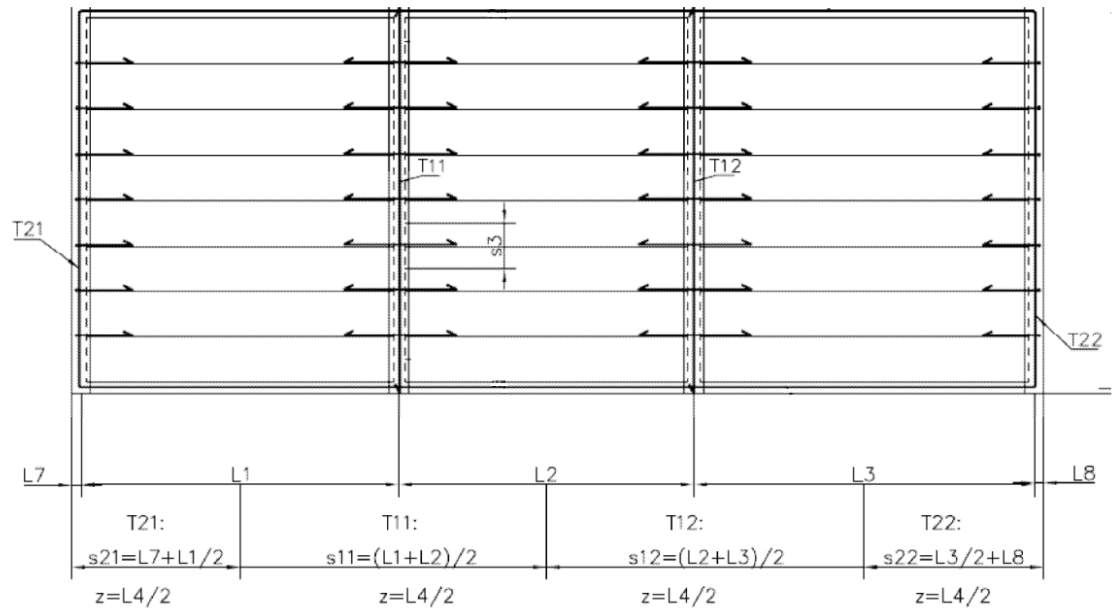

Figure 7 Example of width  $s$  calculation (Betoninormikortti 23, 2012, p. 22)

### 3.1.3 Vertical ties

Continuous vertical ties from the foundations to the roof level will be needed in every column and wall. The columns and walls which carry vertical actions should be able to resist an accidental design tensile load as well as the largest design vertical permanent and temporary load acting on the column from any storey. The tensile force is then anchored to the next floor. In load-bearing wall structures, vertical ties may be placed at the concrete seam or distributed along the length of the wall. The outermost vertical ties are located at a distance of maximum 3m from the free-standing end of that wall. (Ministry of the Environment, 2016, p. 46)

## 3.2 Transfer of shear force in concrete construction

### 3.2.1 Shear at the interface between concrete cast at different time

In precast concrete, when concrete is cast at different times, there is shear that occurs in the interface between new and old concrete. The shear stress at the interface should satisfy the following formula according to SFS-EN 1992-1-1 2004, p. 92.

$$v_{Edi} \leq v_{Rdi}$$

$v_{Edi}$  is the design value of shear stress between old and new concrete's boundary and can be defined as the following formula.

$$v_{Edi} = \frac{\beta \cdot V_{Ed}}{z \cdot b_i}$$

Where:

$\beta$  is the ratio of the longitudinal force in the new concrete area and the total longitudinal force in the tension or compression zone which is calculated for the section considered

$V_{Ed}$  is the transverse shear force

$z$  is the lever arm of composite section

$b_i$  is the width of the interface

$v_{Rdi}$  is the design shear resistance between old and new concrete's boundary.

$$v_{Rdi} = c \cdot f_{ctd} + \mu \cdot \sigma_n + \rho \cdot f_{yd} \cdot (\mu \cdot \sin\alpha + \cos\alpha) \leq 0,5 \cdot v \cdot f_{cd}$$

Where:

$f_{ctd}$  is the design tensile strength,

$\sigma_n$  is stress per unit area caused by the minimum external normal force along the interface that can act simultaneously with the shear force, positive for compression, when  $\sigma_n < 0,6 \cdot f_{ctd}$ , and negative for tension.

When  $\sigma_n$  is tensile  $c \cdot f_{ctd}$  should equal 0,

$$\rho = \frac{A_s}{A_i}$$

$A_s$  is the area of reinforcement crossing the interface, including ordinary shear reinforcement, with sufficient anchorage at two sides of the interface.

$A_i$  is the area of the joint.

$\alpha$  is defined in Figure 8,  $45^\circ \leq \alpha \leq 90^\circ$ .

$v$  is a strength reduction factor,

$$v = 0,6 \cdot \left(1 - \frac{f_{ck}}{250}\right)$$

$c$  and  $\mu$  are factors which is defined by the roughness of the interface, as shown in Table 3 below.

Table 3 Effect of interface roughness (SFS-EN 1992-1-1, 2004, p. 93)

Interface roughness	c
<u>Very smooth</u> : a surface that is cast against plastic, steel or specially prepared wooden moulds	0.25
<u>Smooth</u> : a slipformed or extruded surface, or a free surface left with no extra treatment after vibration	0.350
<u>Rough</u> : a surface with at minimum 3 mm roughness at about 40 mm spacing, achieved by raking, exposing of aggregate or other methods with an equivalent behaviour	0.45
<u>Indented</u> : a surface with indentations like in Figure 8	0.5

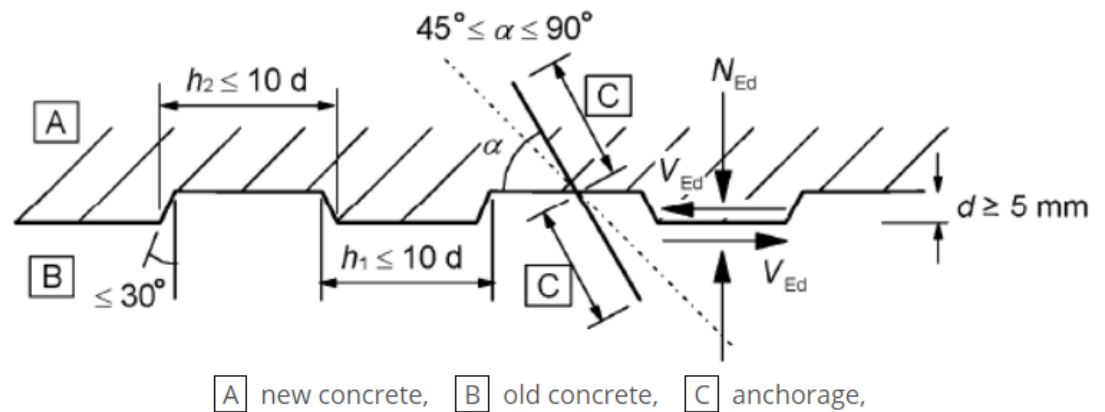

Figure 8 Indented construction joint between new and old concrete (SFS-EN 1992-1-1, 2004, p. 93)

### 3.2.2 Principle of shear force transfer

In order to transfer shear force between concrete elements, adhesion or friction at joint interfaces, shear-key effect at indented joint faces, dowel action of transverse steel bars, pins and bolts, or other mechanical connection devices can be applied. (CEB-FIB, 2008, p. 199)

If a joint face meets certain roughness, shear forces can be transmitted by friction even when the joint is cracked. In general, internal compressive forces are generated along a joint by pull-out resistance of transverse reinforcement bars, bolts, etc. When the joint is subjected to shear sliding, the transverse reinforcement bars, bolts, etc. are strained. In conclusion, it is possible to transfer shear by friction when a joint faces are rough and transverse compression exists. (CEB-FIB, 2008, p. 199)

Figure 9 below shows the compression along the joint.

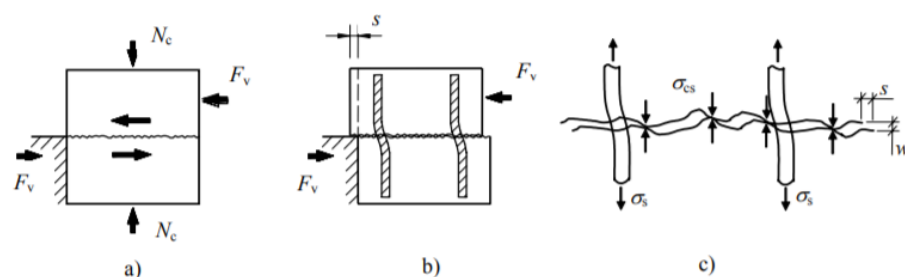

Figure 9 a) External compression along the joint, b) and c) compression is created by transverse bars across the joint (CEB-FIB, 2008, p. 199)

Due to imposed shear displacements, reinforcement bars, bolts, etc. across joints can contribute to the shear resistance by their dowel action as shown in Figure 10 below.

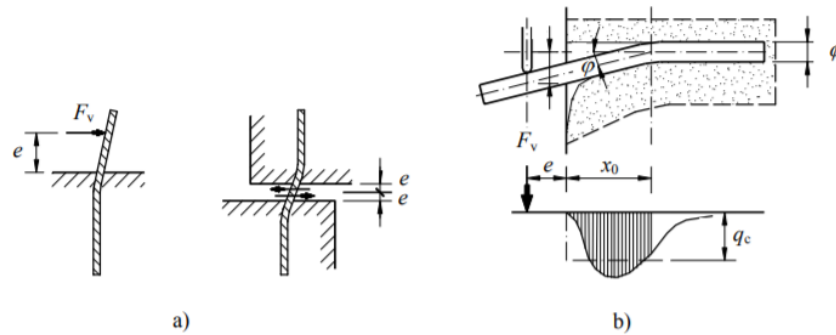

Figure 10 Transferring shear by dowel action in bolt, pin or bar, a) dowel pin in single and double fixation case, b) Failure with plastic hinge in the dowel and the local crushing of concrete (CEB-FIB, 2008, p. 201)

The shear joint resistance by dowel action is calculated from the following formula. (Betoinormikortti 23, 2012, p. 42)

$$V_{Rd} = \frac{1,2 \cdot \phi^2 \cdot \sqrt{f_{ck} \cdot f_{yk}}}{\gamma_c}$$

Where  $\phi$  is diameter of the dowel,  $f_{ck}$  is the concrete strength,  $f_{yk}$  is the steel strength of the dowel and  $\gamma_c$  is partial safety factor for concrete (1,0 in accidents and 1,5 in normal breakdown).

In vertical shear joints, shear key is the most common alternative due to its capability to transfer shear in the mechanical way. The shear keys are part of the joint with or without indented faces. They work as mechanical interlocks and avoid significant slip at the interface. The horizontal component of the inclined compressive force must be balanced by the transverse tensile force.

Figure 11 below shows the diagonal compressive strut across the shear key.

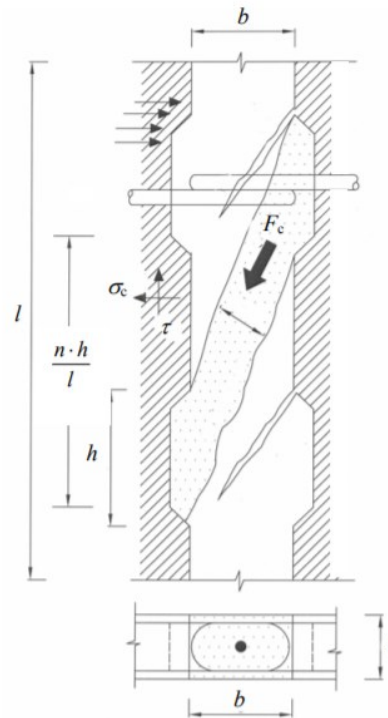

Figure 11 Diagonal compressive strut across the shear key. (CEB-FIB, 2008, p. 248)

When shear is loaded along the joint in this type of connection, the shear resistance depends on the strength of the shear keys with the transverse reinforcement or other tie arrangement. In order to prevent the joint from uncontrolled separation, transverse reinforcement or other transverse tie arrangements are distributed, according to Figure 12. b-c. The transverse reinforcement can be concentrated on the ends of the wall element which is rarely used in Finland (b) or be distributed along the wall's height (c). (CEB-FIB, 2008, p. 200)

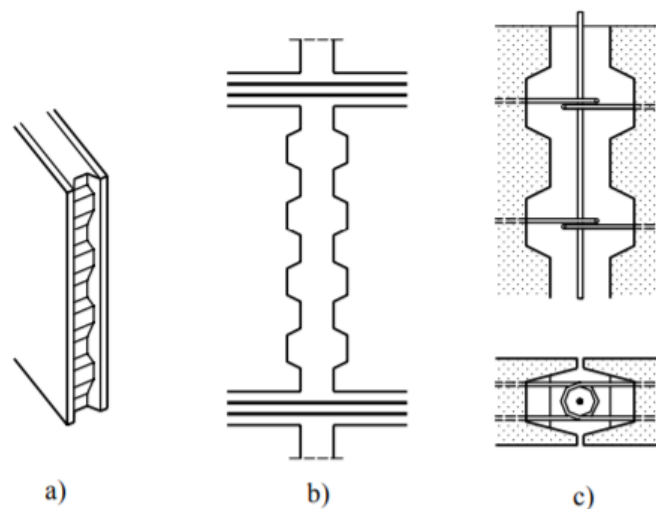

Figure 12 Vertical joint connection between wall panels, a) indented joint face of wall panel, b) tying reinforcement in the horizontal joint, c) overlapping loops along the joint

### 3.2.3 Vertical shear joints of wall elements

Wind load, additional gravity and other horizontal loads cause shear forces on the vertical joints of the elements. The higher the building is, the greater shear forces and bending moments are applied to the lowest layers. These shear forces tend to cause slippage at the interface of the elements. In order to make the elements work as a uniform plate, they must be bonded to each other by load-bearing joints. The most common types of vertical joints in Finland are cable tie connections and steel link joints. When the capacities of these joints exceed the capacity of the heavily loaded joints, it is possible to use additional seam profiling in addition to the steel loops.

Figure 13 below shows the shear forces acting on stiffening tower elements.

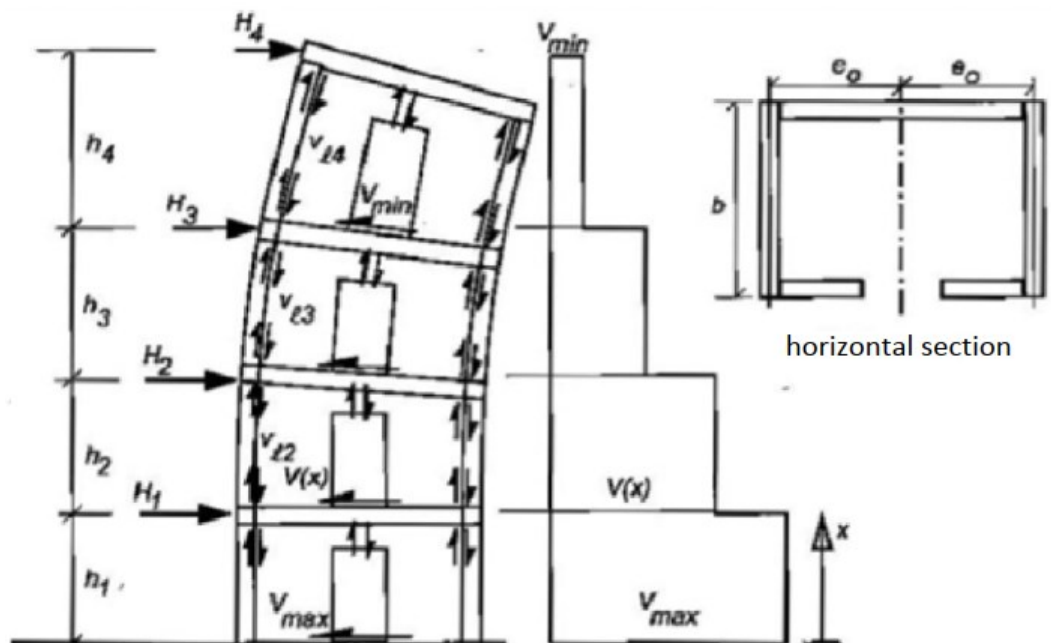

Figure 13 Shear forces of vertical joints in stiffening tower elements (BY210, 2005, p. 571)

Figure 14 below shows the shear forces at joint in consist of 2 wall elements.

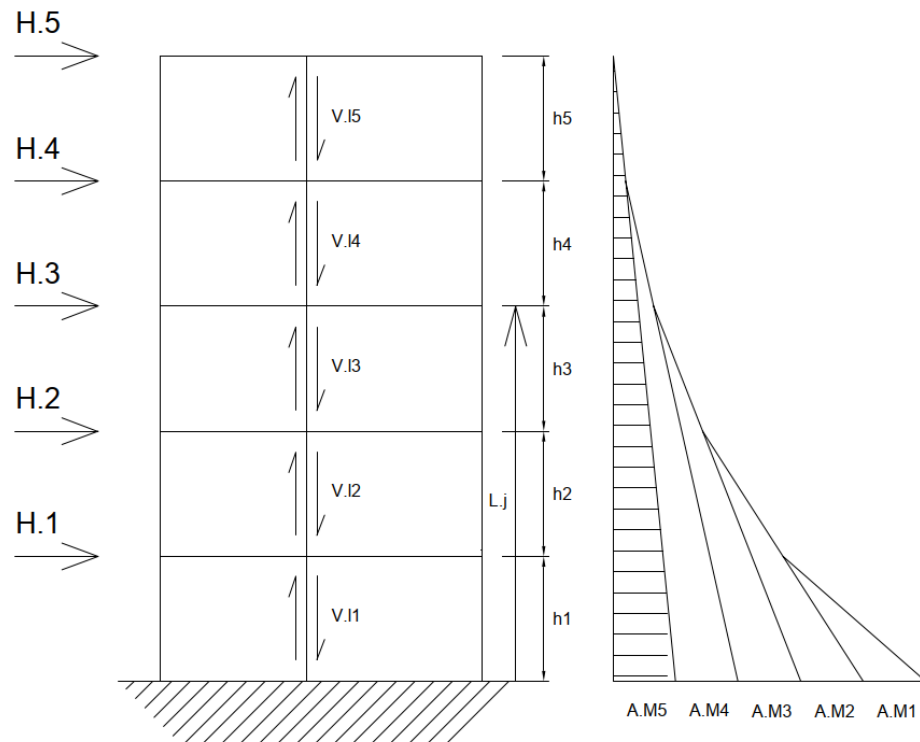

Figure 14 Shear forces at joint in consist of 2 wall elements (BY210, 2005, p. 191)

### 3.3 Vertical Shear joints of wall panels with loop connection

Vertical Shear joint is used to transfer tensile forces, bending moments and shear forces. The connection can meet failure in the result from breach of reinforcement bars, crushing of the joint concrete (mortar) or fracture of the joint concrete in the plane of overlapping loops. The most common types of failure are shown in Figure 15. When there is degradation of shear keys, the shear-key effect decreases and the behaviour changes to a frictional phase. A significant shear slip will happen along the cracked section.

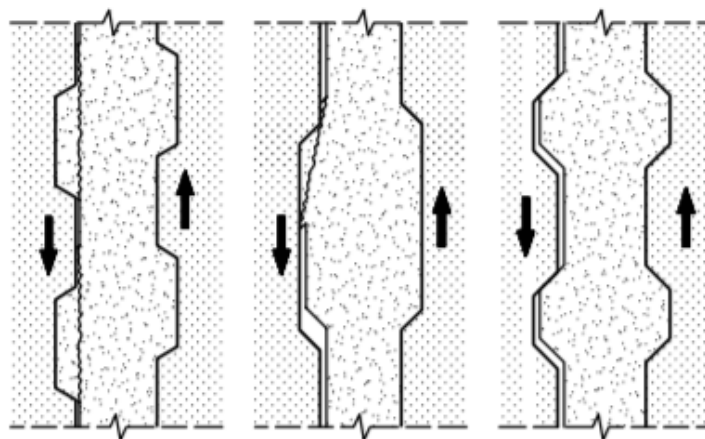

Figure 15 Typical failure types in shear key connection (CEB-FIB, 2008, p. 200)

From left to right, there are longitudinal shearing cracks in keys, crushing and shearing off of key corners. The very right picture is dislocation or slip between the contact surfaces.

In order to achieve the acceptable behaviour, transverse reinforcement in the overlap loop is needed. The tensile force is transferred thanks to inclined compressive struts between loops, as shown in Figure 16. (CEB-FIB, 2008, p. 192)

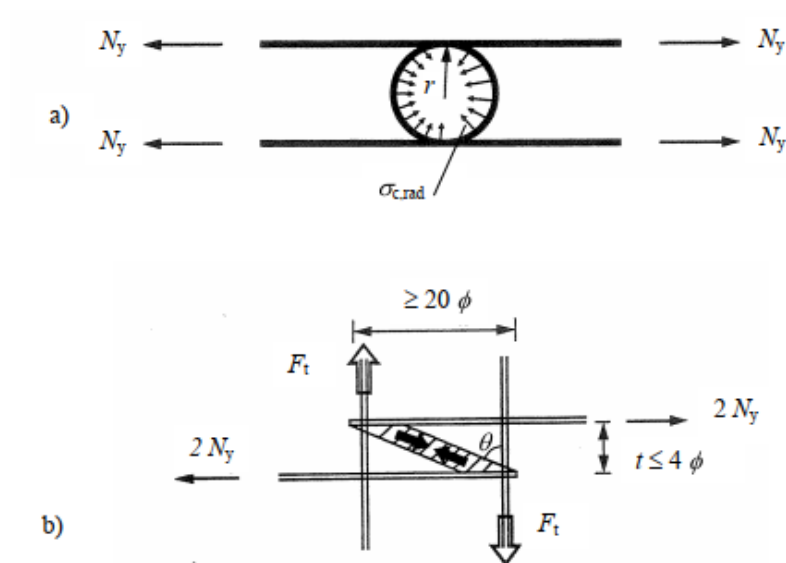

Figure 16 Forces transfer in loop connection, a) radial stress against bending inside loop, b) diagonal compressive strut between overlapping loops (CEB-FIB, 2008, p. 192)

According to CEB-FIB, 2008, pp. 192-193, the minimum transverse force of the lacer reinforcement in order to ensure yielding of the loops is:

$$F_t = 2 \cdot N_y \cdot \cot \theta$$

Where  $N_y$  is the yield load of one leg of U-bar and  $\theta$  is strut inclination between adjacent overlapping U-bars.

The horizontal equilibrium of one U-bar provides this following formula.

$$\sigma_{c,rad} = \frac{\pi \cdot \phi}{4 \cdot r} \cdot f_y$$

Where:

$\sigma_{c,rad}$  is the bearing stress;

$r$  is the bending radius of U-bar;

$\phi$  is the diameter of the U-bar.

The bending radius should meet the following requirement.

$$\begin{cases} r \geq \frac{\pi \cdot \Phi}{4 \cdot \sigma_{c,rad}} \cdot f_y \\ r \geq 8 \cdot \phi \end{cases}$$

A limitation of the bearing stress ( $\sigma_{c,rad}$ ) is shown as:

$$\sigma_{c,rad} \leq \begin{cases} f_c \cdot \sqrt{\frac{b_i}{\phi}} \\ 3 \cdot f_c \end{cases}$$

Where  $b_i = 2 \cdot \left( c_e + \frac{\phi}{2} \right)$  and  $b_i \geq t$ ,

$c_e$  is the concrete cover between U-bar and edge of the element and  $t$  is the transverse spacing of adjacent overlapping loops.

Moreover, the shear resistance of the joint or U-bar connection without a concrete dowel is shown in the following formula. (Betoniinormikortti 23, 2012, p. 43)

$$V_{Rd} = \frac{0,14 \cdot 10^{-3} \cdot \sqrt{f_{ck,s}} \cdot \frac{A_s}{s} \cdot f_{yk}}{\gamma_{c,acc}}$$

Where  $f_{ck,s}$  is the concrete seam cylinder strength in MPa,  $\frac{A_s}{s}$  is the sectional area per meter for various loop spacing in  $mm^2/mm$ ,  $f_{yk}$  is the steel strength of the loop in MPa and  $\gamma_c$  is partial safety factor for concrete (1,0 in accidents and 1,5 in normal breakdown).

### 3.3.1 U-bar connections

Since the 1960s, keyed joints reinforced with overlapping U-bars have been used for vertical shear connections between precast concrete wall elements.

The overlapped U-bars which are normally placed pairwise with contact form a cylindrical core in the connection. Such shear connections are subsequently grouted with mortar. The reinforcement, or so-called locking bar(s), is placed in the cylindrical core. In practice, the assembly sequence of the precast elements requires that wall elements have to be installed vertically. In addition, the connection operation is only possible when the overlapping U-bars are bent up prior to installation. The U-bars are straightened again to form the loops when the elements are placed in the desired position. (Jørgensen, 2014, p. 126)

Hence, this will cause the reduction of steel strength if U-bars are re-bent.

Figure 17 below shows the wall connection using U-bars.

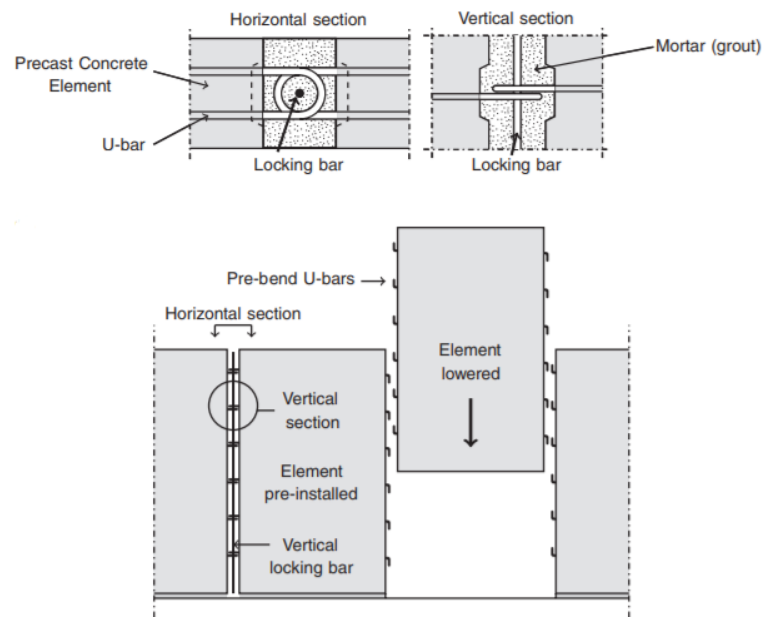

Figure 17 Transverse, overlapping U-bars distributed along the joint (Sørensen, Hoang, Olesen, & Fischer, 2017, p. 190)

When U-bars with the diameter larger than 10 – 12 mm, bending up and manual straightening after installation is not an ideal option. Therefore, normally, 6 – 8 mm U-bars are used. However, due to the small diameter, the connection procedure will limit the cross-section area of the bars, which also limit the strength of joint. Hence, such U-bar connection can be considered as a ductile connection. The conventional shear connection is not feasible to use, for example, in shear walls of tall buildings with considerable horizontal loads. (Sørensen, Hoang, Olesen, & Fischer, 2017, p. 190)

Table 4 below indicates the shear resistance of the joint without a concrete dowel for different diameter of U-bars and concrete seam strength. The calculation is based on the method shown in Chapter 3.3, p. 20.

Table 4 Shear resistance of the joint without a concrete dowel for different diameter of U-bars and concrete seam strength

The shear resistance of the joint without a concrete dowel	
$V_{Rd} =$	$(0,14 * 0,001 * \text{SQRT}(f_{ck,s}) * A_{s/s} * f_{yk}) / \gamma_c$ kN/m
$f_{ck,s} =$	concrete seam cylinder strength in Mpa
$A_{s/s} =$	the sectional area per meter for various loop spacing in $[(\text{mm})^2 / \text{mm}]$
$f_{yk} =$	the steel strength of the loop in Mpa
$\gamma_c =$	partial safety factor for concrete (1,0 in accidents and 1,5 in normal breakdown).

$f_{ck,s}$ (MPa)	$f_{yk}$ (MPa)	$\phi$ (mm)	k/k (mm)	$\gamma_c$	$A_{s/s}$ (mm <sup>2</sup> /m)	$V_{Rd}$ (kN/m)
30	500	8	300	1,0	335	<b>128,5</b>
30	500	8	150	1,5	670	<b>171,3</b>
30	500	10	300	1,5	524	<b>133,8</b>
30	500	10	150	1,5	1047	<b>267,7</b>
30	500	12	300	1,5	754	<b>192,7</b>
30	500	12	150	1,5	1508	<b>385,4</b>
35	500	12	150	1,5	1508	<b>416,3</b>
25	500	8	300	1,5	335	<b>78,2</b>
25	500	10	300	1,5	524	<b>122,2</b>
25	500	12	300	1,5	754	<b>175,9</b>
35	500	16	300	1,5	1340	<b>370,1</b>
40	500	12	150	1,5	1508	<b>445,1</b>

### 3.3.2 Wire loops connection

Similar to U-bar loop connection which is discussed in Section 2.3.1, the wire loops form a cylindrical core in which the transverse reinforcement is placed. The connection is also grouted with concrete. However, understanding the difficulty of U-bar connection in bending stiffness, the wire loop connection has the advantage of being flexible; in other words, they have virtually no bending stiffness, which makes vertical installation for precast concrete elements (wall panels) easier.

In this section, three wire loops products from different suppliers are studied. These products are Peikko PVL® Connecting Loops, shown in Figure 18 below, Halfen HLB Loop Box and RSteel RVL Single Wire Loop Box.



Figure 18 PVL® Connecting Loops (Peikko, Technical Manual. PVL® Connecting Loop. Wall Connecting Loop Box with single wire, 2019, p. 2)

Wire ropes using in the loops are high strength wires ( $f_u > 1000 \text{ MPa}$ ). Different from normal reinforcement, the wires ropes have no ductile stress-strain relationship and have a brittle tensile failure without yield plateau. (Jørgensen, 2014, p. 129)

According to the ductility characteristics in Eurocode 2, 2004, the wire ropes do not meet the requirement. The stress-strain curves for typical hot rolled and cold worked steel are shown below in Figure 19.

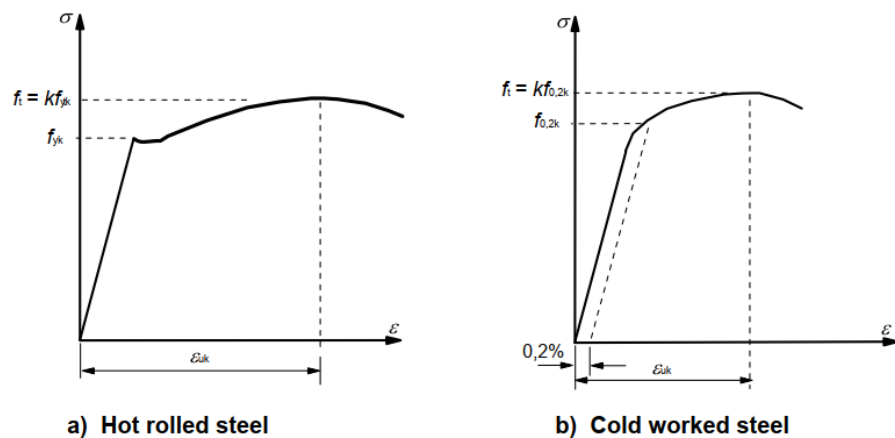

Figure 19 Absolute values for stress-strain diagrams of typical reinforcement steel (SFS-EN 1992-1-1, 2004, p. 39)

The load-displacement curves for test of wire ropes provided by Peikko are shown in the following figure 20 (Jørgensen, 2014, p. 132).

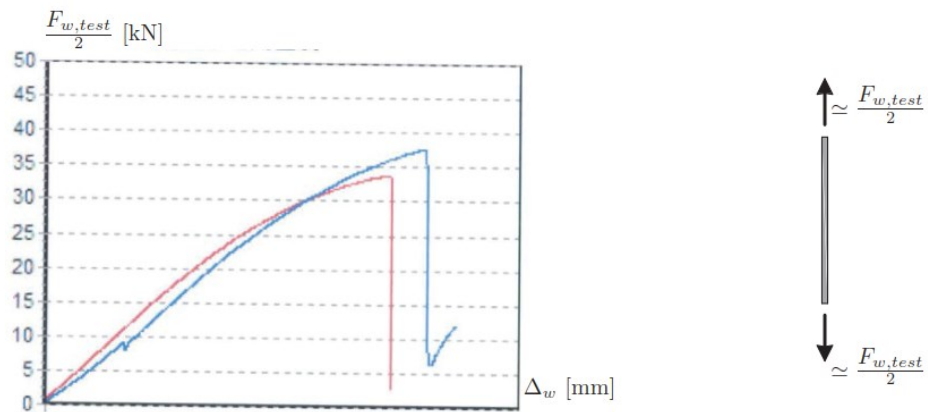

Figure 20 Wire rope test of PVL wire loop

To overcome the problem of brittle failure and to redistribute stress, loop connections should be designed as “the strongest link” in the connection (Jørgensen, 2014, p. 133).

Wire loops connection transfers tension loads perpendicular to the joint by the overlap of wire loop. The compression loads are transmitted to the grout fill when the loops are tensioned. This tension load must be taken up by the vertical reinforcement bars. It is recommended to specify a tension load that does not exceed 10kN per loop in characteristic value in consideration of the serviceability limit state. (Halfen, 2016, p. 12)

The wire loop, in general, is designed to transfer vertical shear forces, transverse shear forces and tensile forces.

Figure 21 below shows the transfer of tension loads perpendicular to the joint.

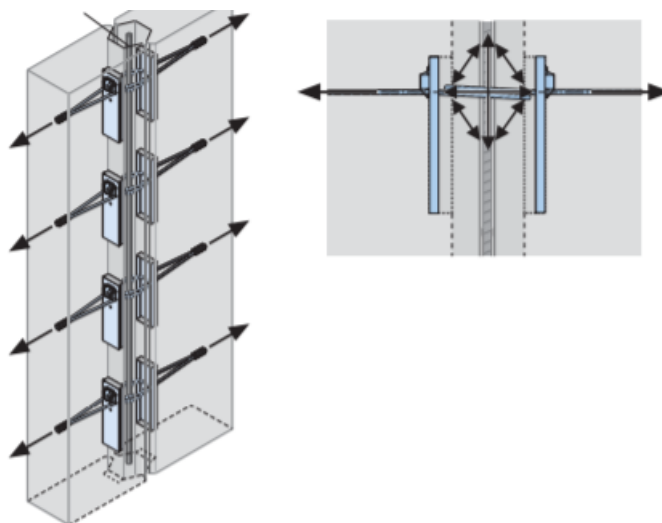

Figure 21 Direction of tensile force (Halfen, 2016, p. 12)

It is assumed that the strut is formed between the concrete flanks of the opposing precast elements. The overlapping cable loops transfer the tension load. To transfer the shear loads perpendicular to the joint, it is important to consider the geometry of the joint and the transverse reinforcement. (Halfen, 2016, p. 13)

Figure 22 below shows the shear force perpendicular to the joint.

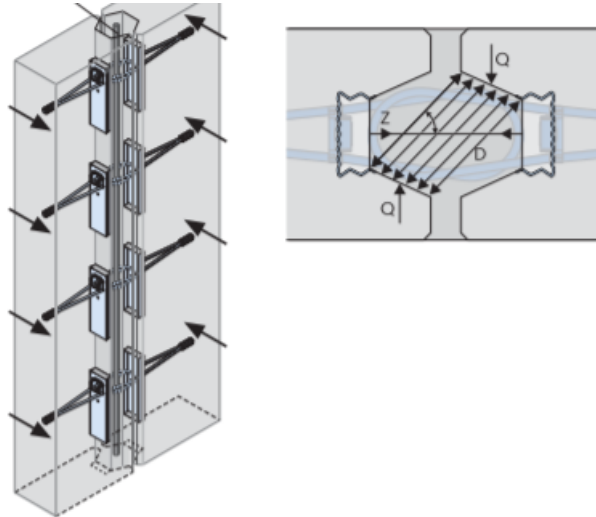

Figure 22: Shear force perpendicular to the joint (Halfen, 2016, p. 13)

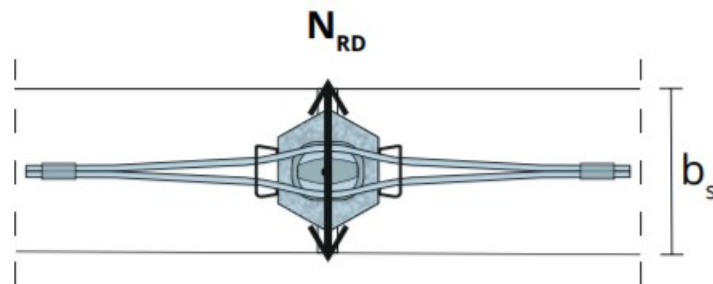

Figure 23 Direction of transversal shear force (Halfen, 2016, p. 13)

The value of the tension and compression loads which is formed by shear loads parallel to the joint shown in the Figure 23 above depends on the angle  $\vartheta$  shown in the following Figure 24. The tension load is then transferred to the overlapping loops. (Halfen, 2016, p. 12)

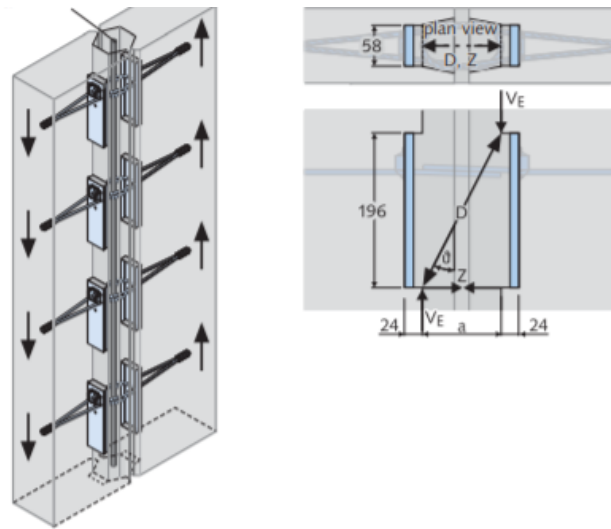

Figure 24 Vertical shear force acting on the connection (Halfen, 2016, p. 12)

Resistances of wire loops connections are dependent on the loop spacing and compression strength of the concrete seam. The concrete seam is recommended to have minimum the same compression strength as the concrete used for wall panels, minimum C25/30 (Peikko, Technical Manual. PVL® Connecting Loop. Wall Connecting Loop Box with single wire, 2019, p. 27).

Different wire loop products from various supplier give different technical resistance value.

The tensile resistance for different types of PVL Connecting loop is defined according to Table 5 below.

Table 5 Tensile resistance of PVL®60-120, PVL®140 and PVL®SOLO Wire loop (Peikko, Technical Manual. PVL® Connecting Loop. Wall Connecting Loop Box with single wire, 2019, p. 10)

Grouting/wall	Tensile resistance $N_{t,Rd}$ [kN/pair of boxes]					
	C25/30	C30/37	C35/45	C40/50	C45/55	C50/60
PVL® 60-120	10.7	12.8	15.0	17.1	19.3	21.4
PVL® 140	25.6	30.7	35.8	36.1	36.1	36.1
PVL® SOLO	25.6	30.7	35.8	36.1	36.1	36.1

Hence, the tensile resistances of PVL Connecting Loop per meter will be:

$$\Sigma N_{t,Rd} = \eta_{PVL} \cdot N_{t,Rd} \text{ [kN/m]}$$

Where:

$$\eta_{PVL} = \text{Number of PVL® Connecting Loop pairs per 1m length of joint [pcs]}$$

Table 6-9 show the design vertical shear resistance of PVL products from Peikko.

Table 6 Design vertical shear resistance of PVL®60-120, PVL®140 and PVL®SOLO Wire loop (Peikko, Technical Manual. PVL® Connecting Loop.

Wall Connecting Loop Box with single wire, 2019, p. 11)

Grouting/wall	Vertical shear resistance $V_{Rd,  }$ [kN/pair of boxes]					
	C25/30	C30/37	C35/45	C40/50	C45/55	C50/60
PVL® 60-120	14.5	16.9	19.4	22.1	24.6	27.1
PVL® 140	31.5	37.0	42.5	44.2	45.1	46.0
PVL® SOLO	28.1	33.3	38.4	39.5	40.1	40.6

Hence, the vertical shear resistances of PVL Connecting Loop per meter will be:

$$\Sigma V_{Rd,||} = \eta_{PVL} \cdot V_{Rd,||} \text{ [kN/m]}$$

Where:

$$\eta_{PVL} = \text{Number of PVL® Connecting Loop pairs per 1m length of joint [pcs]}$$

In other words, with the same calculation, the vertical shear resistance of PVL Connection Loop per metre can be shown as in Tables 7-8.

Table 7 Design vertical shear resistance per metre of PVL®60-120 Wire loop (Peikko, 2012, p. 6)

Concrete strength (EC 2)	Spacing of loops [mm]										
	250	300	350	400	450	500	550	600	650	700	750
C25/30	153	132	116	105	96	89	83	78	74	70	67
C30/37	156	134	119	107	99	91	86	81	77	73	70
C35/45	158	137	122	110	101	94	88	83	79	76	73
C40/50	162	141	126	114	105	98	92	88	83	80	77
C45/55	165	144	128	117	108	101	95	90	86	83	80
C50/60	168	146	131	120	111	104	98	93	89	85	82

Table 8 Design vertical shear resistance per metre of PVL®140 Wire loop (Peikko, 2012, p. 6)

Concrete strength (EC 2)	Spacing of loops [mm]							
	350	400	450	500	550	600	650	700
C25/30	170	153	137	123	112	103	96	90
C30/37	185	165	148	134	121	111	103	97
C35/45	197	177	158	143	130	119	110	103
C40/50	209	188	167	151	138	128	117	109

The design transverse shear resistance of PVL products is determined in the Table 9. In this part, only smooth joint is taken into account.

Table 9: Transverse shear resistance for PVL®60-120, PVL®140 and PVL®SOLO (Peikko, 2019, p. 13)

Wall thickness [mm]	Min. $b_{wall}$ [mm]	Transverse shear resistance $V_{Rd,\perp}$ [kN/pair of boxes]					
		C25/30	C30/37	C35/45	C40/50	C45/55	C50/60
PVL® 60-120	120	3.0	3.3	3.7	4.2	4.5	4.8
PVL® 140	150	3.4	3.7	4.1	4.7	5.1	5.4
PVL® SOLO	150	2.0	2.2	2.4	2.8	3.0	3.2

Hence, the transverse shear resistances of PVL Connecting Loop per meter will be:

$$\Sigma V_{Rd,\perp,3} = \eta_{PVL} \cdot V_{Rd,\perp,2} \text{ [kN/m]}$$

Where:

$\eta_{PVL}$  = Number of PVL® Connecting Loop pairs per 1m length of joint [pcs]

According to RSteel Single loop box technical manual, the resistance for combined forces is calculated as the following equation

$$\frac{V_{Ed}}{V_{Rd}} + \frac{N_{Ed}}{N_{Rd}} + \frac{F_{Ed}}{F_{Rd}} \leq 1$$

Where  $V_{Ed}$ ,  $N_{Ed}$  and  $F_{Ed}$  are design value of longitudinal shear force, transversal shear force and tensile force sequentially.  $V_{Rd}$ ,  $N_{Rd}$  and  $F_{Rd}$  are design value of resistance of longitudinal shear force, transversal shear force and tensile force sequentially.

Resistance calculation does not take cracks or deformations within the joint into consideration. Also, the steel boxes and the seam are assumed to be fully filled with concrete (RSteel, 2018, p. 17). However, this matter is raised in the real life construction situation where the concrete seam pouring, extra (vertical or horizontal) reinforcement and the geometry of wire loop and also of U-bar connection meet some certain difficulty. This matter will be discussed in the Section 6.

There are some rules when using wire loop connection for precast concrete wall elements. When it comes to connection for fire resistance load bearing walls, the concrete cover should be taken into account so that the wire loop will not reach its critical temperature; for example, in PVL connecting loops, critical temperature is 350°C. Moreover, the loops cannot be used for lifting purposes. Last but not least, the connection loops cannot be used in the joints where there are seismic or dynamic strains that exceed the deformation capacity of the concrete seam. (Peikko, 2012, pp. 4-5)

According to Halfen, if imposed deformations cannot be excluded, the crack width of the concrete seam must not restrictedly exceed 0.3mm. Transverse loads do not lead to an extra crack opening. (Halfen, 2016, p. 7)

## 4 CASE STUDIES

### 4.1 Procedure for determining consequences classes

The graph shown in Figure 25 below is a summary of definitions of consequences classes for different type of building and occupancy according to National Building Code of Finland, National annexes to

Eurocode SFS-EN 1991, 2016. This matter was pointed out in the section 2.4.

Along with these definitions, accidental cases were considered within different consequences classes.

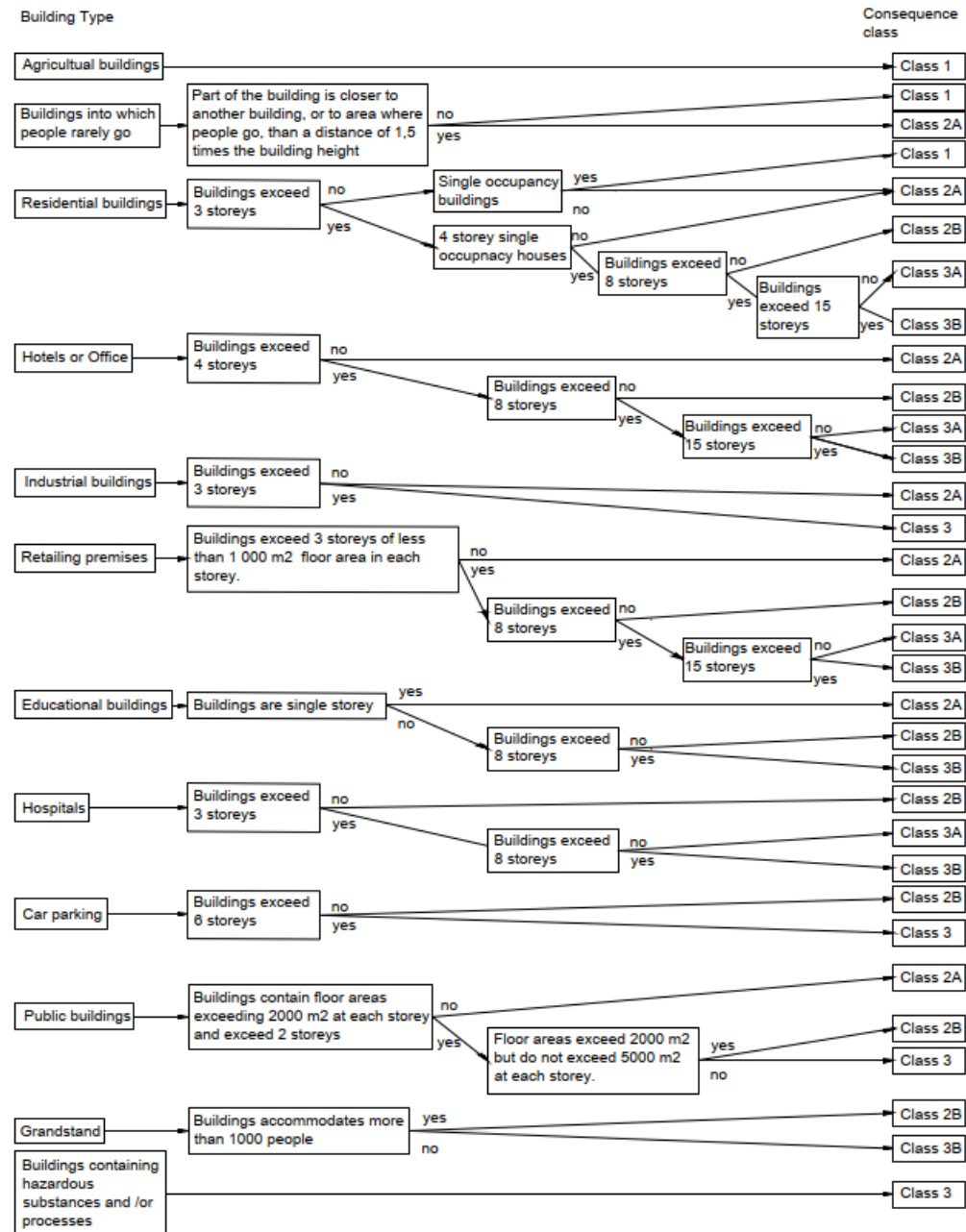

Figure 25 Procedures for determining consequences classes according to National Building Code of Finland, National annexes to Eurocode SFS-EN 1991, 2016

For consequence class 1 and consequence class 2a, the vertical tie is designed following the SFS-EN 1992-1-1, section 9.10. Moreover, the vertical reinforcement bars to support such ties or so-called transverse steel bars are taken into account according to the technical manual of vertical shear joints for wall panels, for example PVL Connecting Loop Technical Manual. In these consequence classes, there is no specific consideration for vertical tie regarding accidental actions from

unidentified reason. These matters or rules were discussed in more detail in Chapter 2.4.

In consequence class 2b and 3a, accidental cases are considered, for vertical ties especially, according to Betoninormikortti 23, 2012, pp. 31-32, the load-bearing or stiffening wall element is attached to the upper load-bearing structure by a vertical force of magnitude.

$$F_v = G_s + G_k + Q_k$$

Where:

$G_s$  is the weight of the wall element

$G_k$  is the characteristic value of a constant load on the wall element from a single layer

$Q_k$  is the specific value of the variable loads on a wall element from a single layer

The fastening can also be placed in a vertical seam between the wall elements, provided that the centre distance of the fasteners does not exceed 6 m. If the required fasteners described above are placed in joints between wall elements, the force transfer from element to seam must be ensured by pins or loops extending from the edge of the element to the seam. The total capacity per element is equivalent to the required joint force  $F_v$ , as shown in Figure 26 below.

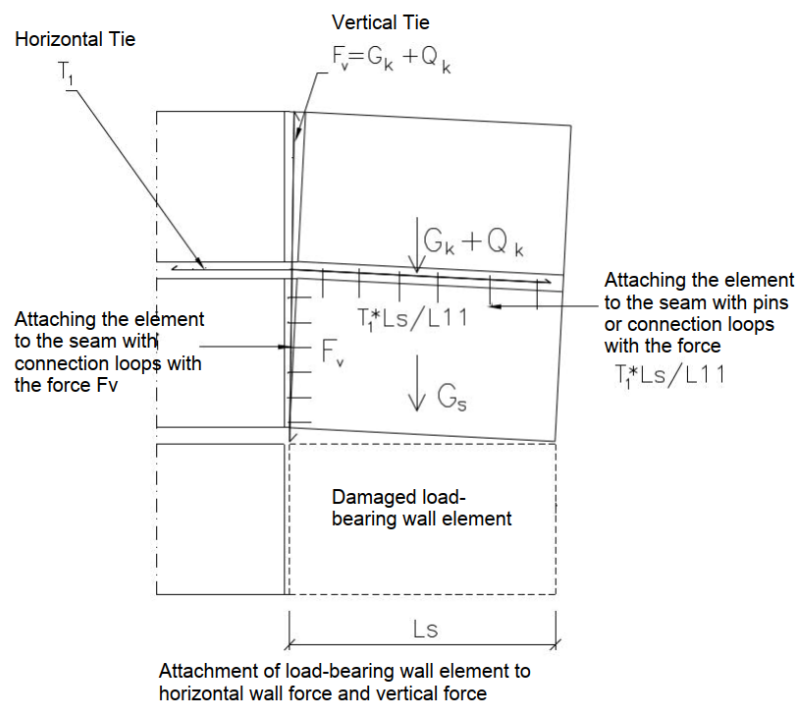

Figure 26: Tie system and tie force in load-bearing wall element (Betoninormikortti 23, 2012, p. 32)

## 4.2 General information

The study case examined in the thesis is an example of an office building. The building is eight stories height with three shear cores. According to

the above information of the building and information given in the section 2.4 and 4.1, the consequence class used to determine the structural design method is CC2b.

In this case, accidental cases will be taken into account in the calculation. Overall view of the building is shown in Tekla model in Figure 27 below, and plan view is shown in Figure 28.

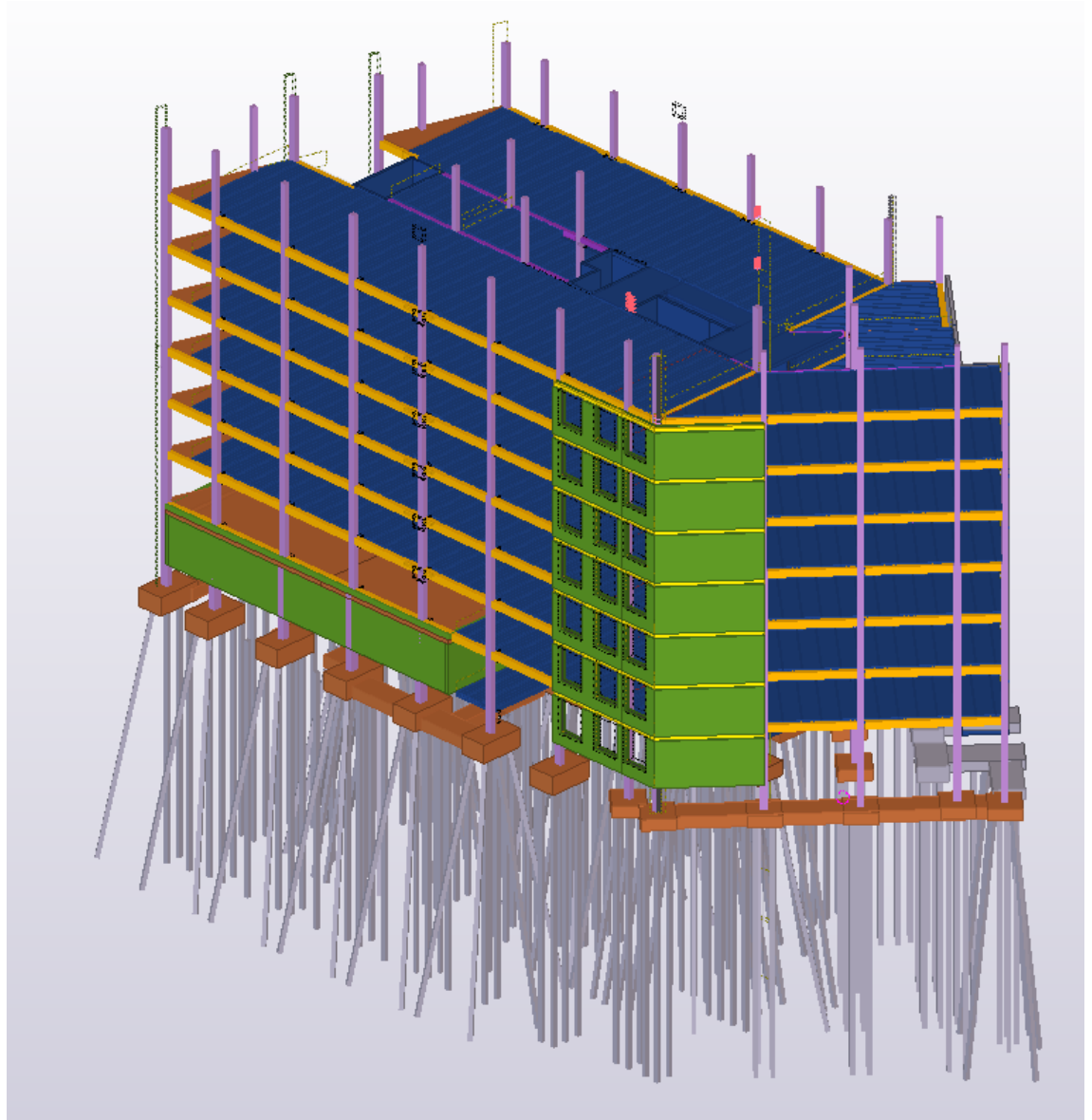

Figure 27 Overall view of project model

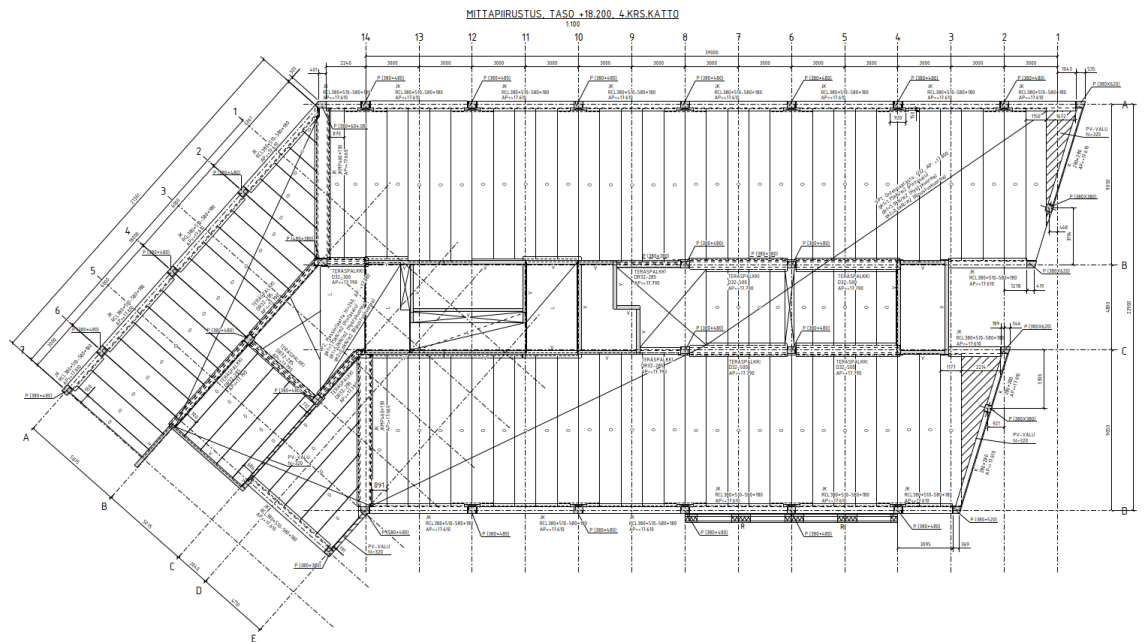

Figure 28 Plan view of the office building (4<sup>th</sup> floor view)

#### 4.3 ROBOT Structural Analysis

A model view of the reference project was separated by using ROBOT Structural Analysis. The model view is shown below in Figure 29.

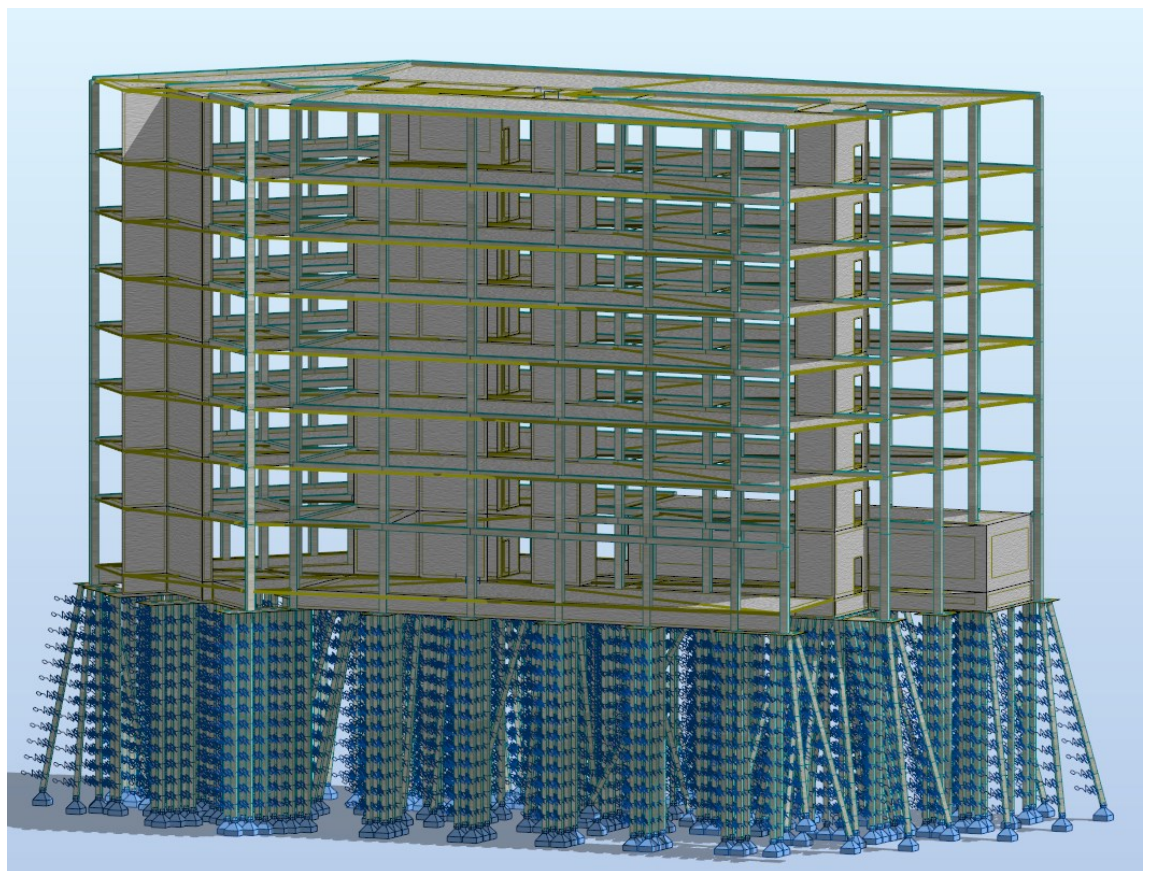

Figure 29 General ROBOT model view of the reference project

#### 4.3.1 General loads

The given structure is subjected to four load types. These types of loads are dead loads, live loads, wind loads and additional loads which results in the imperfection of the building. The loads are categorized according to their nature in Table 10. This thesis only focuses on vertical shear connection between wall elements. The critical load combinations that have the most effect on vertical shear in walls are listed in Tables 10-12.

Table 10 Types of loads applied to the structure

Cases	Loads	Nature
1	Self weight	Dead load
1	Surface load	Dead load
2	Live load	Live load
3	Wind load on the shorter surface of the building	Wind load
4	Wind load on the longer surface of the building	Wind load
5	Horizontal load on the shorter side	Geometric imperfection
6	Horizontal load on the longer side	Geometric imperfection
7	Snow load	Live load
8	ULS/1	Load Combination
9	ULS/2	
10	ULS/3	
11	ULS/4	
12	ULS/5	
13	ULS/6	
14	ULS/7	
15	ULS/8	
16	ULS/9	
17	ULS/10	
18	ULS/11	
19	ULS/12	

In Table 11, load values are defined in different load cases. The load combinations are defined according to Eurocode SFS-EN 1990 in Equation 6.10.

$$\sum_{j \geq 1} \gamma_{G,j} G_{k,j} + \gamma_P P + \gamma_{Q,1} Q_{k,1} + \sum_{i > 1} \gamma_{Q,i} \psi_{0,i} Q_{k,i}$$

Table 12 gives such combination in this example project.

Table 11 Load value

Load Case	Load Values	Description
1	PZ Negative Factor=1,00* self-weight	Robot automatically takes the self-weight of each element
1	PZ=-1,75(kN/m <sup>2</sup> )	Surface load on all floors
1	FZ=-950,00(kN)	Point load acts on the last column at 7th storey
2	PZ=-5,60(kN/m <sup>2</sup> )	Live load on all floors
2	PZ=-3,00(kN/m <sup>2</sup> )	Live load on stairs
2	PZ=-10,00(kN/m <sup>2</sup> )	Live load in special condition area/storage areas
3	PY=3,40(kN/m)	Wind load in the windward direction in y direction
3	PY=2,20(kN/m)	Wind load in the leeward direction y direction
3	PX=3,00(kN/m)	Wind load in the leeward direction x direction
4	PY=-3,40(kN/m)	Wind load in the windward direction y direction
4	PY=-2,00(kN/m) local	Wind load in the windward direction x direction
4	PY=-2,20(kN/m)	Wind load in the leeward direction y direction
4	PX=4,00(kN/m)	Wind load in the leeward direction x direction
4	PX=1,00(kN/m)	Wind load in the leeward direction x direction
5	PY	The values for the horizontal load due to imperfection are shown in Figure
6	PY	The values for the horizontal load due to imperfection are shown in Figure
7	PZ=-2,20(kN/m <sup>2</sup> )	Snow load

Table 12 Load combinations

Load Combinations	Definition
8	ULS/1=1*1.27 + 5*0.90 + 3*1.65
9	ULS/2=1*1.27 + 5*1.27 + 3*1.65
10	ULS/3=1*1.27 + 6*0.90 + 4*1.65
11	ULS/4=1*1.27 + 6*1.27 + 4*1.65
12	ULS/5=1*0.90 + 5*0.90 + 3*1.65
13	ULS/6=1*0.90 + 5*1.27 + 3*1.65
14	ULS/7=1*0.90 + 6*0.90 + 4*1.65
15	ULS/8=1*0.90 + 6*1.27 + 4*1.65
16	ULS/9=1*1.27 + 5*0.90 + 2*1.15 + 3*1.65 + 7*1.15
17	ULS/10=1*1.27 + 5*1.27 + 2*1.15 + 3*1.65 + 7*1.15
18	ULS/11=1*1.27 + 6*0.90 + 2*1.15 + 4*1.65 + 7*1.15
19	ULS/12=1*1.27 + 6*1.27 + 2*1.15 + 4*1.65 + 7*1.15

#### 4.3.2 Wind loads

Wind loads are calculated according to EN1991-1-4. The direction of wind loads applied to the superstructure is shown in Figure 30 and Figure 31.

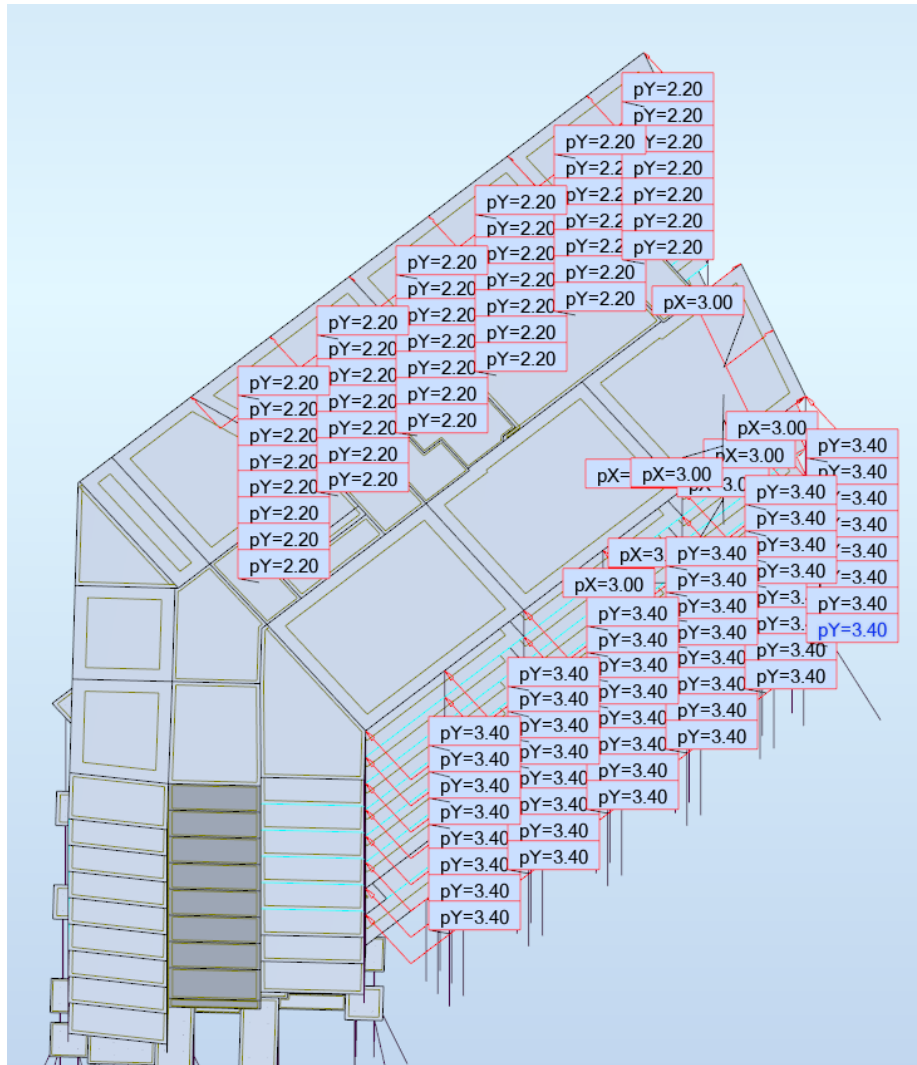

Figure 30 Wind loads in the shorter surface of the building (+y direction)

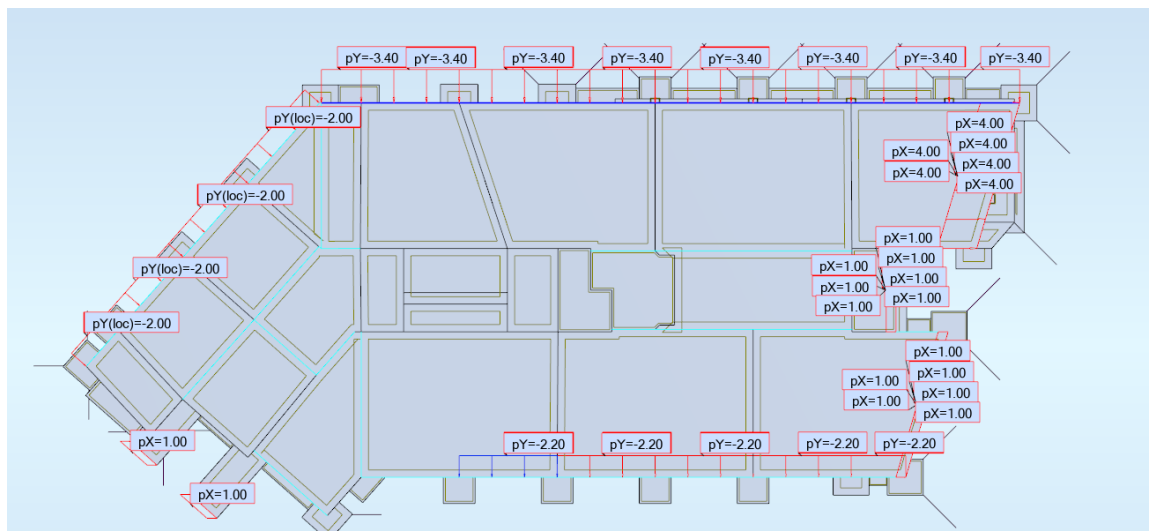

Figure 31 Wind loads in the shorter surface of the building (-y direction)

#### 4.3.3 Geometric imperfection

Horizontal loads due to geometric imperfection are calculated following the method given in Eurocode 1992-1-1, section 5.2. It is noted that the

horizontal loads are calculated from the design vertical loads. Therefore, these loads were not multiplied with any additional factor. Figure 31 and Figure 32 show the horizontal loads acting on the building.

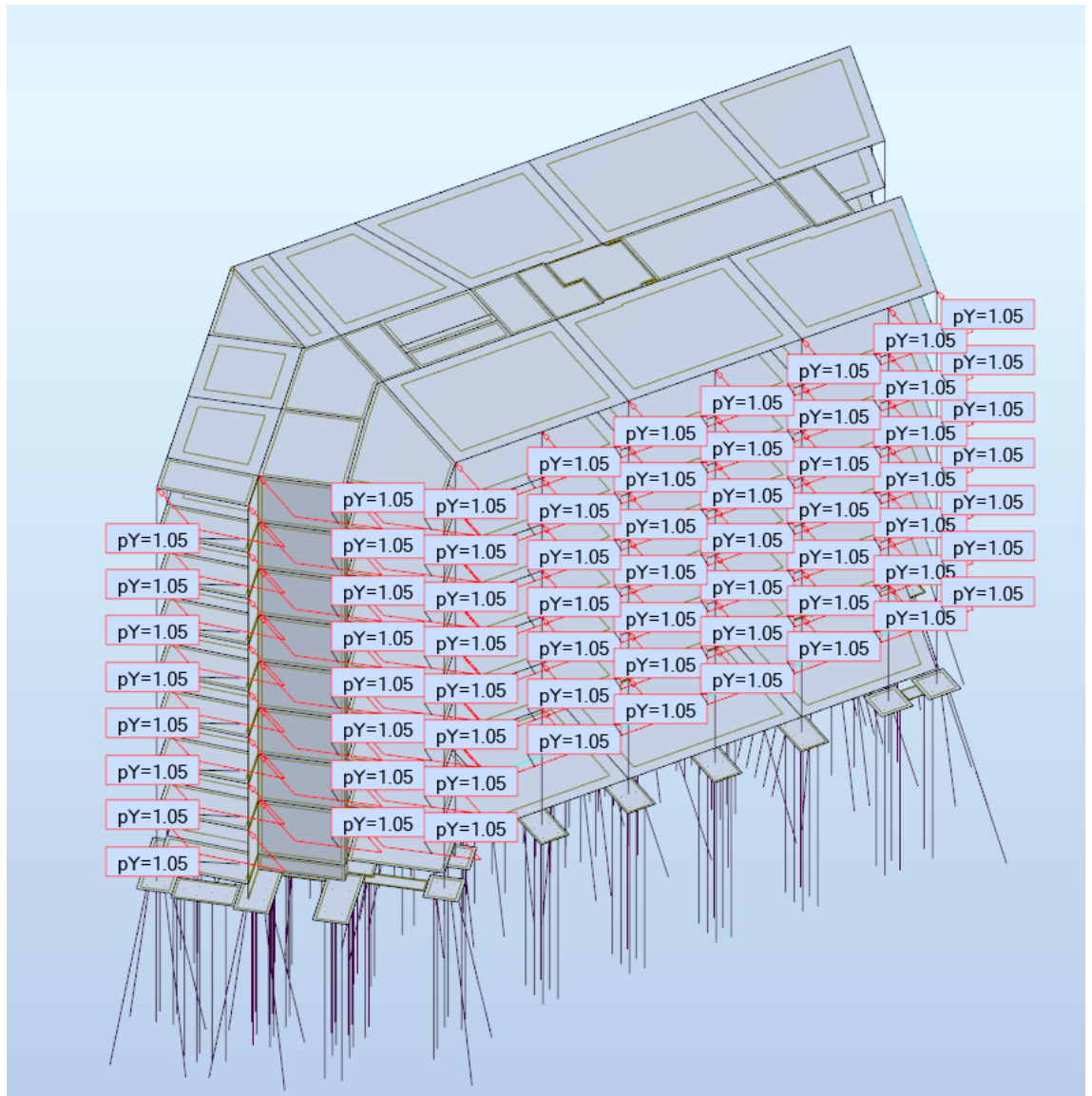

Figure 31 Horizontal load in +y direction of the building.

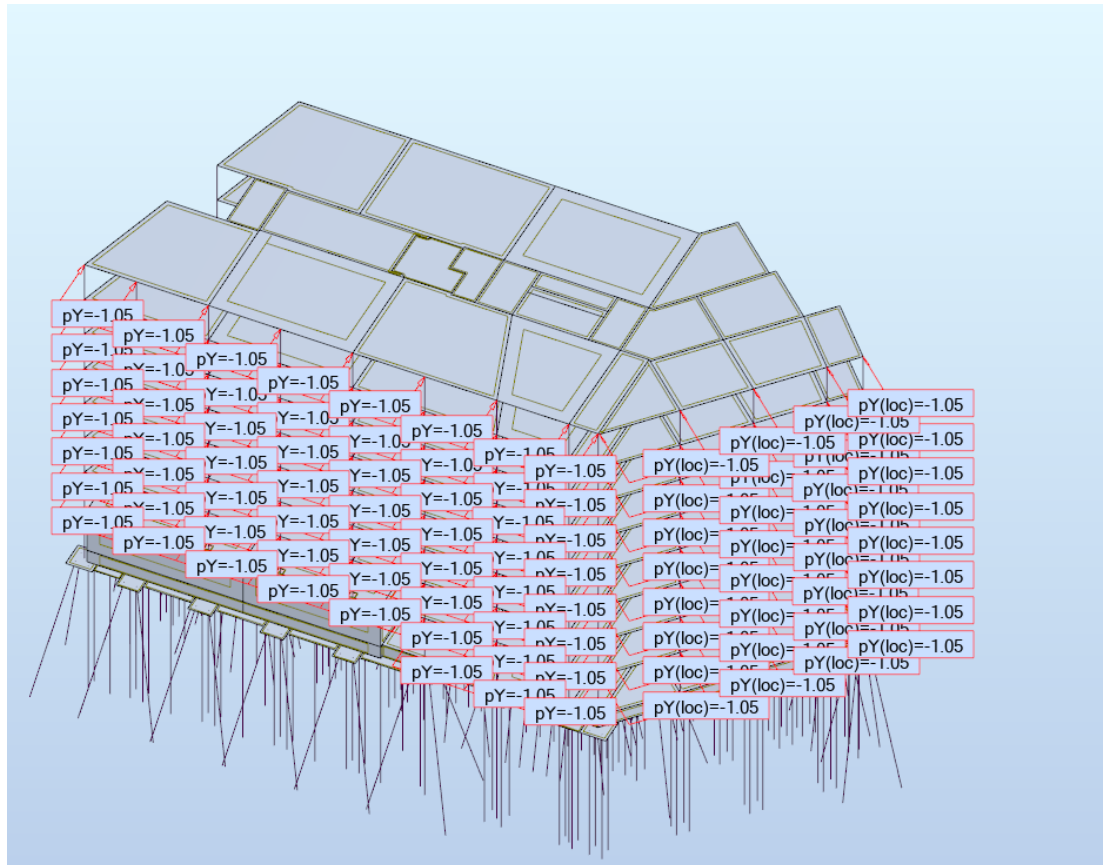

Figure 32 Horizontal load in -y direction of the building.

#### 4.3.4 Results

The shear core marked with letter X shown in Figure 33 was used as reference in designing shear connecting between wall panels. The concrete strength used for the seam is C30/37.

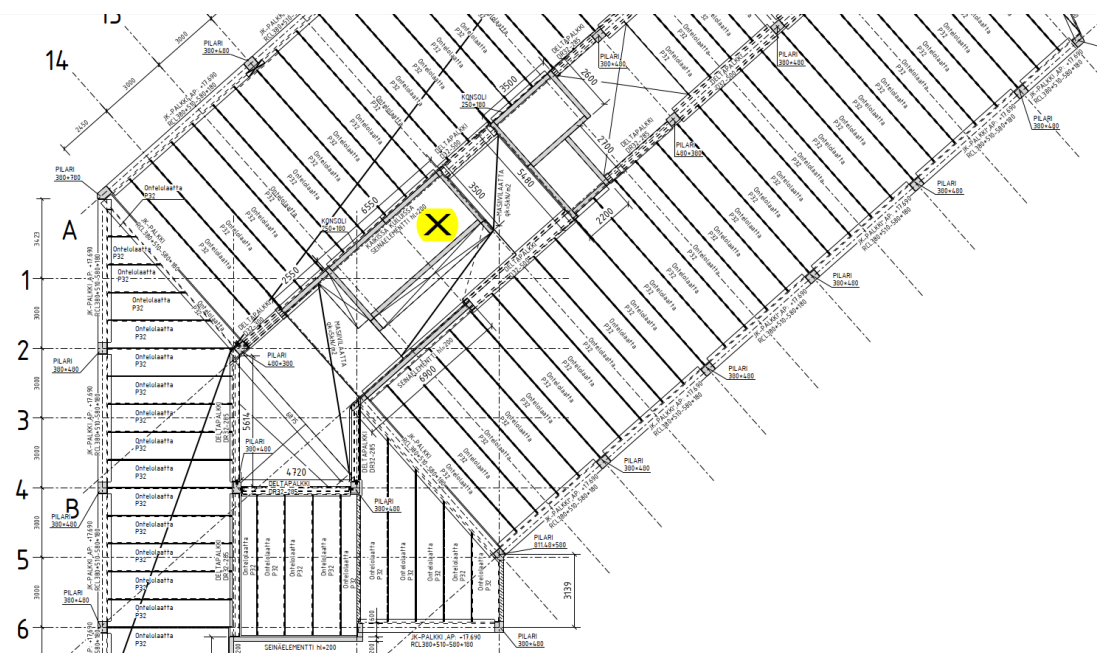

Figure 33 Part of project's dimensional drawing and location of reference shear core

By using Panel Cuts method or Reduced Results in Robot, Figures 34-35 give a result for shear between two panels. The result is taken from load combination 15 which is pointed out in Table 11, in Chapter 4.3.1, p. 34.

On the first floor of the building, it is noticed that the shear force is the biggest.

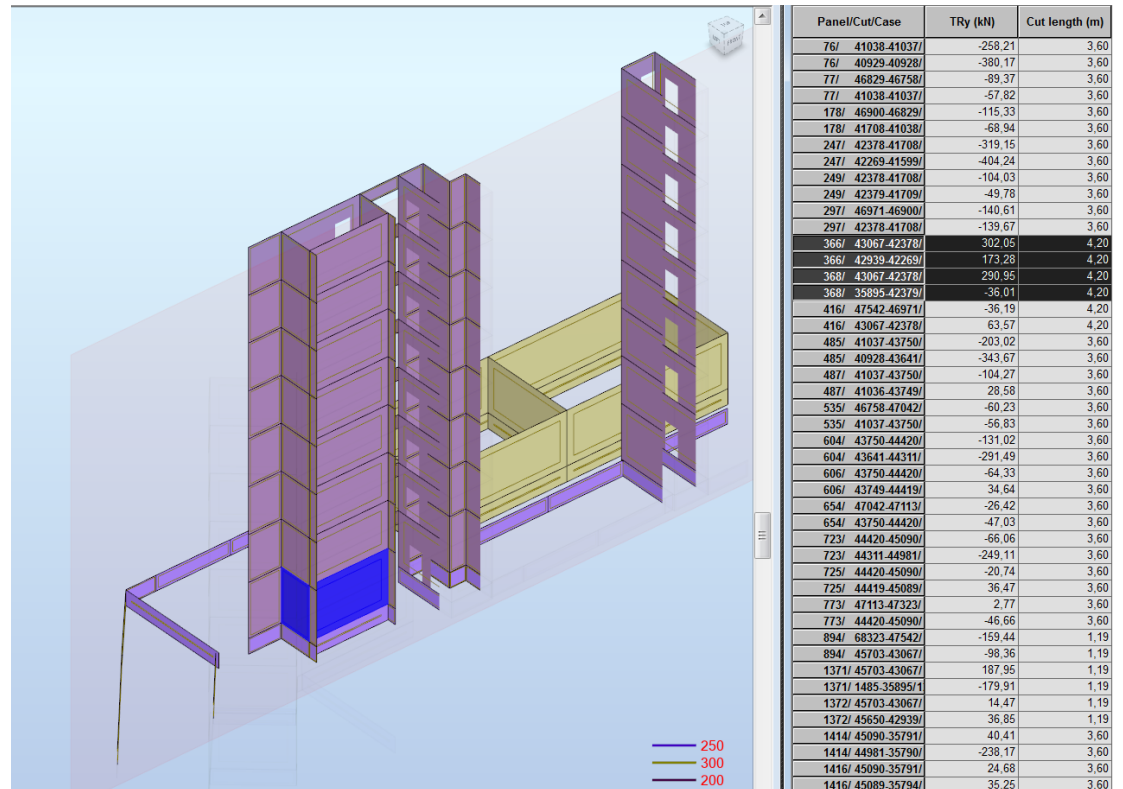

Figure 34: Vertical shear in wall panels of the referent building

In Figure 34, the first column shows the selected panels, their cut which is defined by two nodes at the end of the panels and the load case that is currently analysed. The second column shows the shearing force in panel cut. The panel height is given in the last column.

Selecting only the two panels in the first level, we have the following results. It is noticed that with load combination 15 shown in Table 12, mentioned in Chapter 4.3.1, p. 34, the shear in that cut is the biggest among four corners of the shear core. In other words, that corner gives the most critical shear load in that case. Hence, choosing shear joint connection for each storey will be based on that corner shear result.

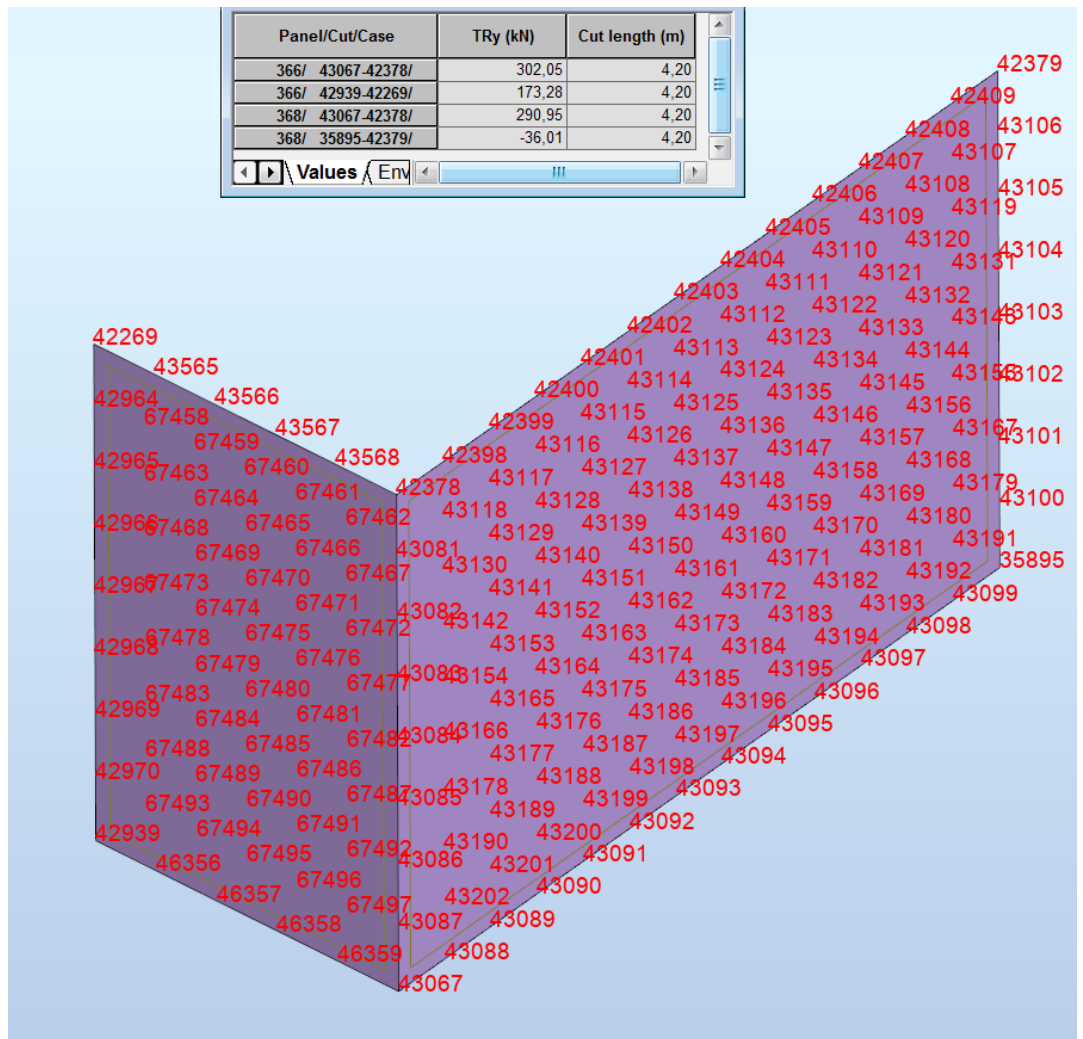

Figure 35 Selected panels in the first floor and their shearing force at the cut

Two panels meet at the cut 43067-42378. The shear of the smaller panel (panel 366 as in "Reduced results for panels" table) in the joint is 302.05kN. For the bigger panel (panel 3638), the shear is 290,95kN. Hence, with the height of panel is 4.2m, the vertical shear in meter is about 141.2kN/m.

Applying the same method, the vertical shear result in wall joints of that shear core is given in Table 13 below. According to Peikko-PVL Connecting Loop vertical shear resistance provided in table 7 and table 8 in Chapter 3.3.2, p. 27, wire loops were applied in different level.

Table 13 Vertical shear result in wall joint

Level	Vertical shear in wall joint (kN/m)	Wire loops	Spacing of loops	Concrete seam strenght	Design shear resistance (kN/m)
1	141,19	PVL140	400	C30/37	165
2	117,55	PVL80	300		134
3	128,52		300		134
4	110,27		300		134
5	85,36		300		134
6	54,26		600		81
7	24,11		600		81
8	18,08		600		81

#### 4.3.5 Accidental case

In accidental cases, as mentioned in section 2.4, for consequences class CC2b, the design method can be whether to design well-performed connecting horizontal and vertical ties or to design a “key element”. For this example project, calculating and designing connecting tie is applied. The calculation sheet is presented in Appendix 1.

## 5 TEKLA MODELING

### 5.1 Manufacturer’s recommendation

When using shear connection loop, in order to design the shear connection for wall elements, Peikko gives some recommendations for the minimum thickness of the concrete wall and positioning of the PVL<sup>®</sup> Connecting Loop. It is noticed that these recommendations will be various between different shear connection loop types from different producers.

The minimum values of the wall panel thickness and the joint width are listed in Table 14.

Table 14 Minimum wall thickness values and width of joint (Peikko, 2019, p. 6)

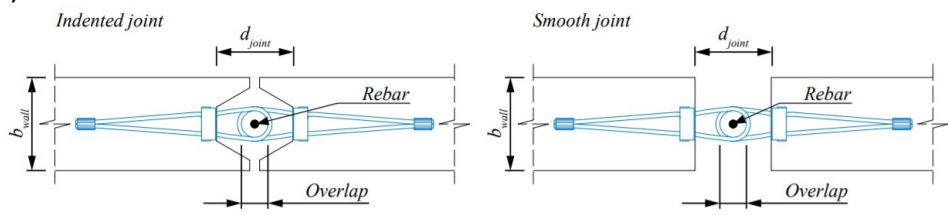

PVL® Connecting Loop	$b_{wall}$ [mm]	$d_{joint}$ [mm]	Overlap [mm]	Wall type
PVL® 140	150	160	120	Load-bearing
PVL® SOLO	150	100	60	Load-bearing
PVL® 120	120	140	100	Load-bearing
PVL® 100	120	120	80	Load-bearing
PVL® 80	80	100	60	Non-load-bearing
PVL® 60	80	80	40	Non-load-bearing

Another factor that plays an important role in designing connection shear connection is the position of the loop according to geometry of joint. This matter is shown in Figures 36-38 below.

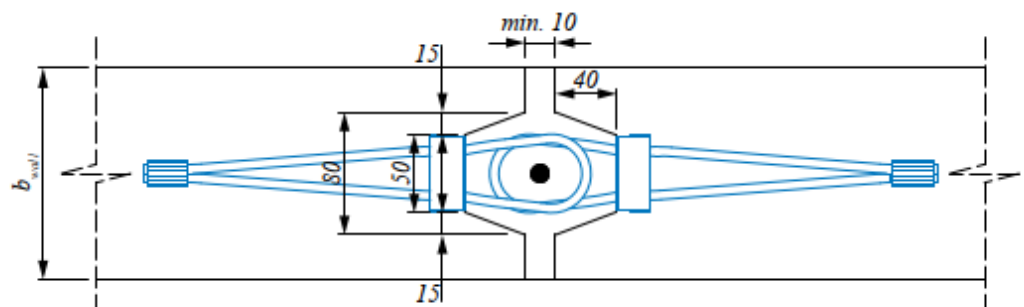

Figure 36 Recommended dimensions of the joint for PVL® 60-120 (Peikko, 2019, p. 7)

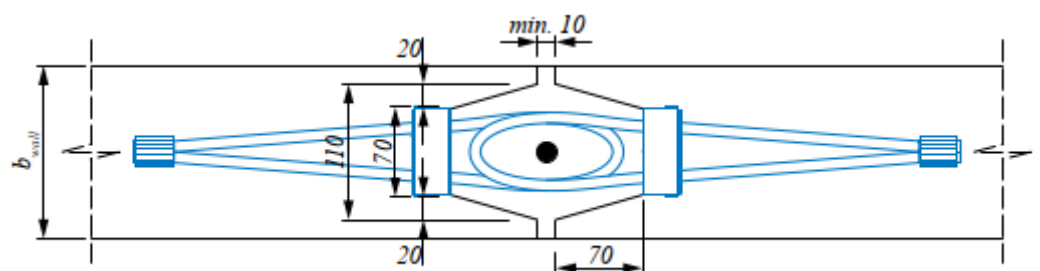

Figure 37 Recommended dimensions of the joint for PVL® 140 (Peikko, 2019, p. 7)

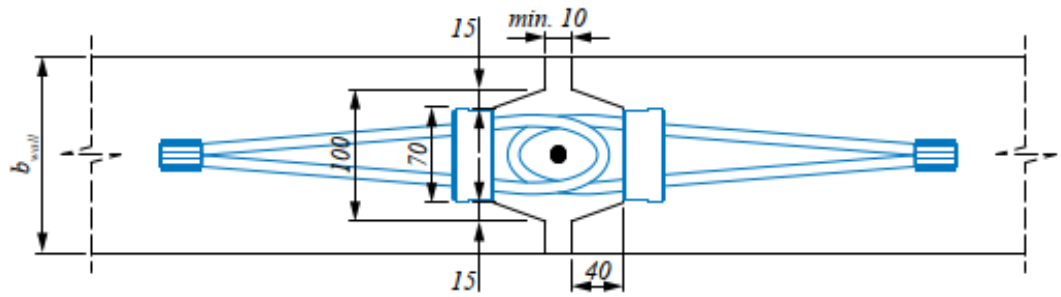

Figure 38 Recommended dimensions of the joint for PVL® SOLO (Peikko, 2019, p. 7)

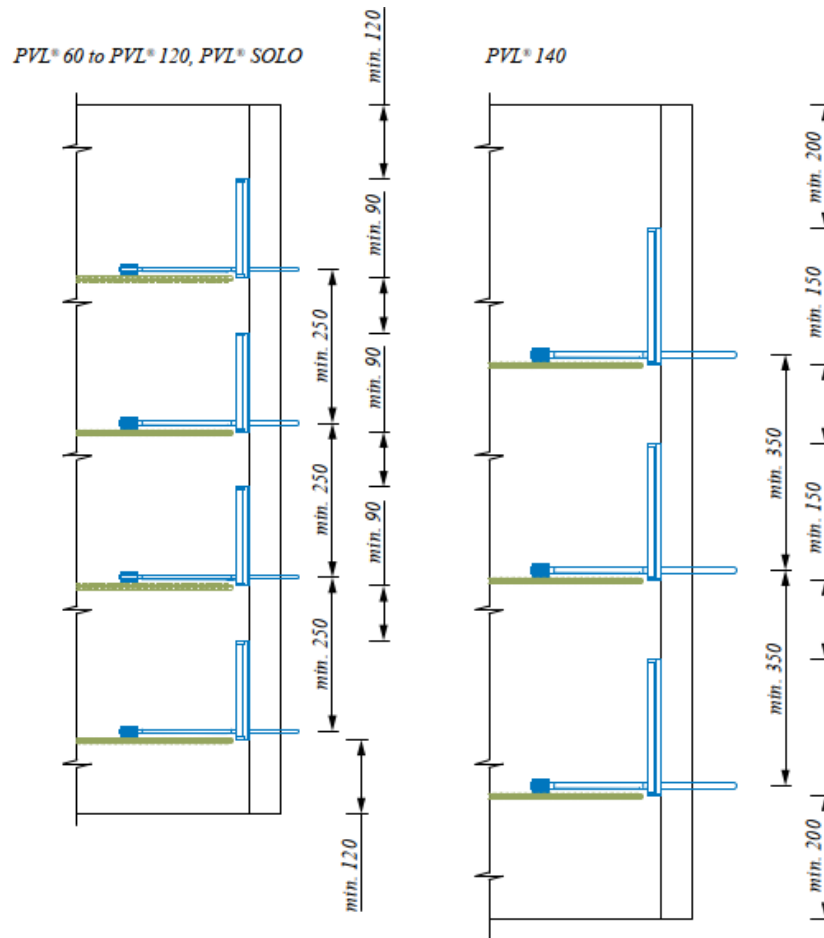

Figure 39 Minimum spacing of the joint for PVL® Connecting Loop (Peikko, 2019, p. 8)

When choosing U-bar connection (or Peikko TS Joint/ ARBOX® Joint reinforcement), the product dimensions can be found in Peikko ARBOX® Joint Reinforcement manual. The product types that are highly focused on and commonly used in such shear connection are ARBOX K and ARBOX C (or TSK and TSC in another version name), which are shown below in Figure 40.

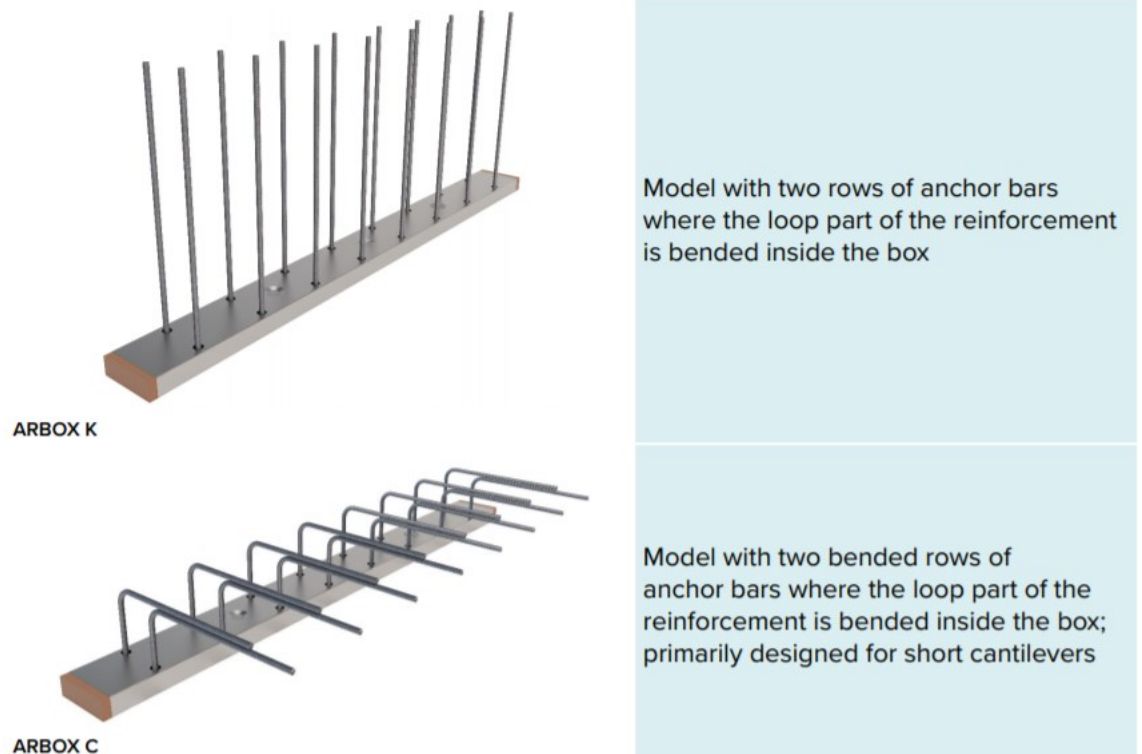

Figure 40 ARBOX® Joint Reinforcement product properties according to Peikko- ARBOX® Joint Reinforcement Technical Manual-version 02/2019

In practice, in order to fulfil all requirements of connecting loop products as well as the preference of factory when making wall panels along the loops, the geometry of joint is modified like in the appendix 1. The reasons for these changes are discussed in Section 6: On-site comments/experiences.

## 5.2 Reference project

In the reference project, some recommend positioning of connecting loops and their settings are also made in Tekla Structures  
Figure 41 is the general Tekla model of the project that is calculated in Chapter 4.

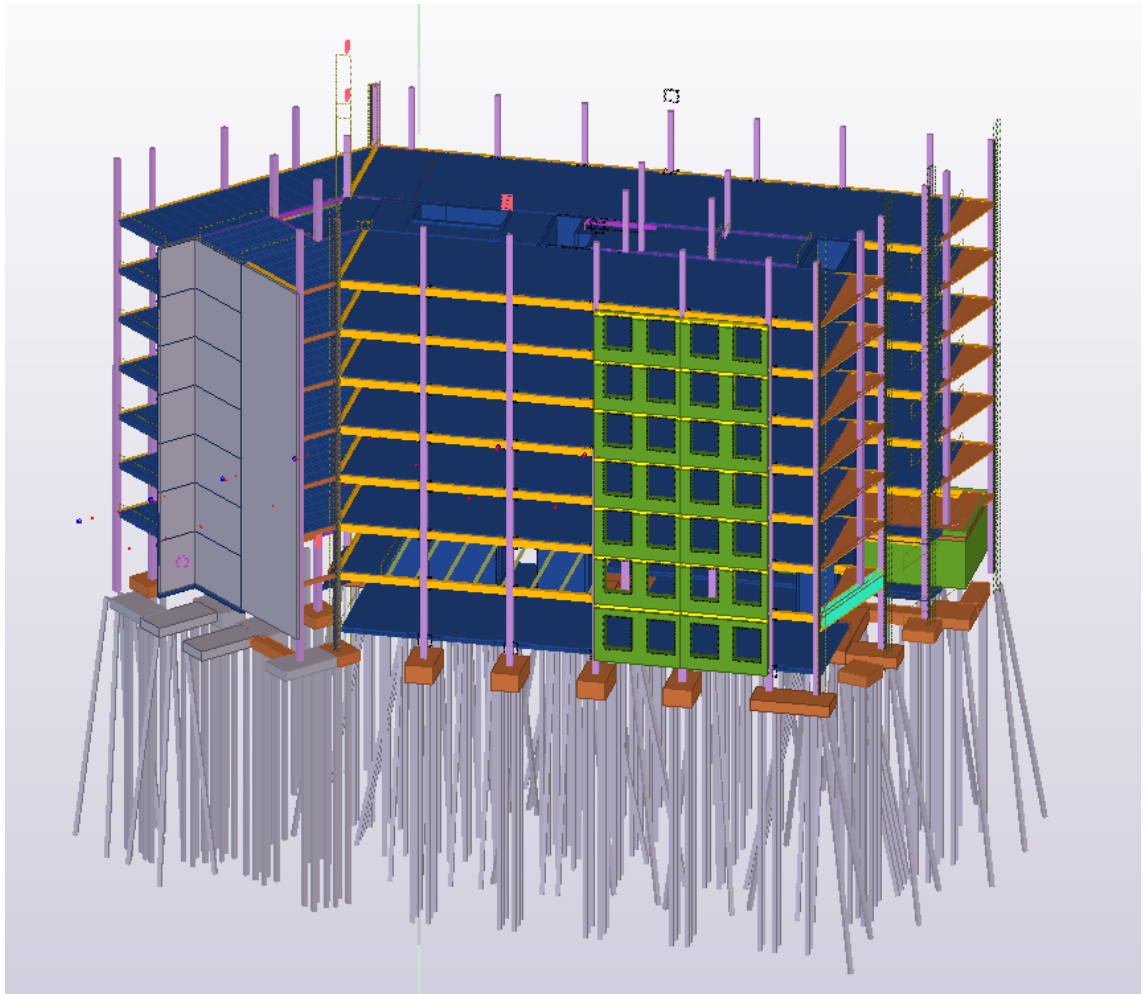

Figure 41 Overall view of project model

Calculated from section 4, PVL<sup>®</sup>80 and PVL<sup>®</sup>140 are used to resist the vertical shear in wall panels.

The shear resistance for PVL140 k400 is 165kN/m with C30/37 concrete seam strength. This is applied in the first floor of the building. In the second to the fifth floor PVL80 k300 is used. In this case, the shear resistance capacity is 134kN/m. The other last floors have PVL80 k600 with the shear resistance of 81kN/m (Peikko, 2012, p. 6).

Figure 42 below shows the settings for edge shape between two walls with PVL<sup>®</sup>80.

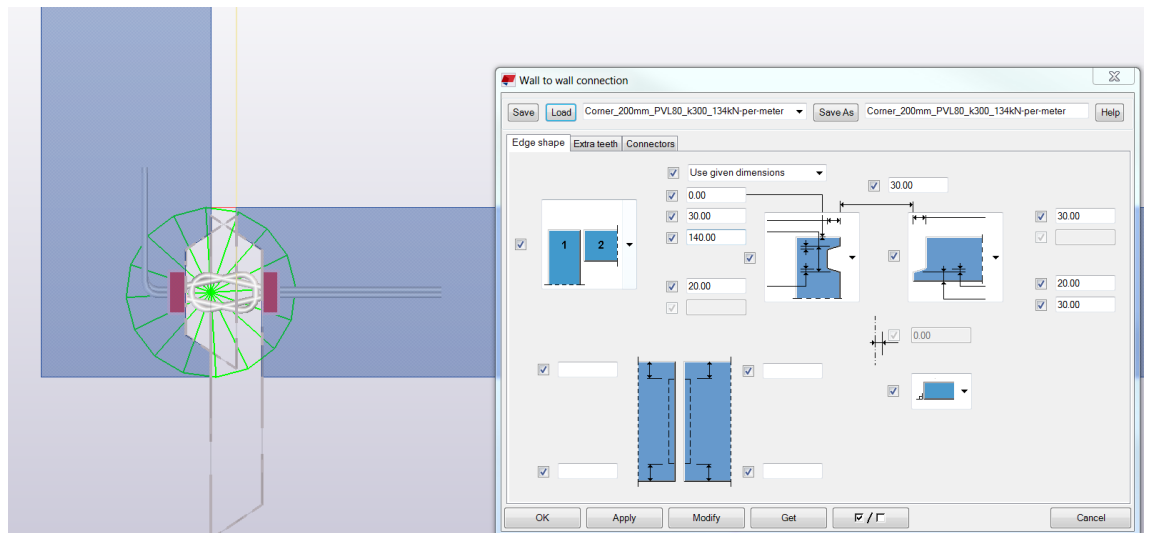

Figure 42 Settings for geometry of the corner joint when using PVL®80 k300

In more detail, the dimension for such a joint is shown in Figure 43 below. With different spacing, various shear resistance values are pointed out according to Peikko-PVL Connecting Loop Technical Manual.

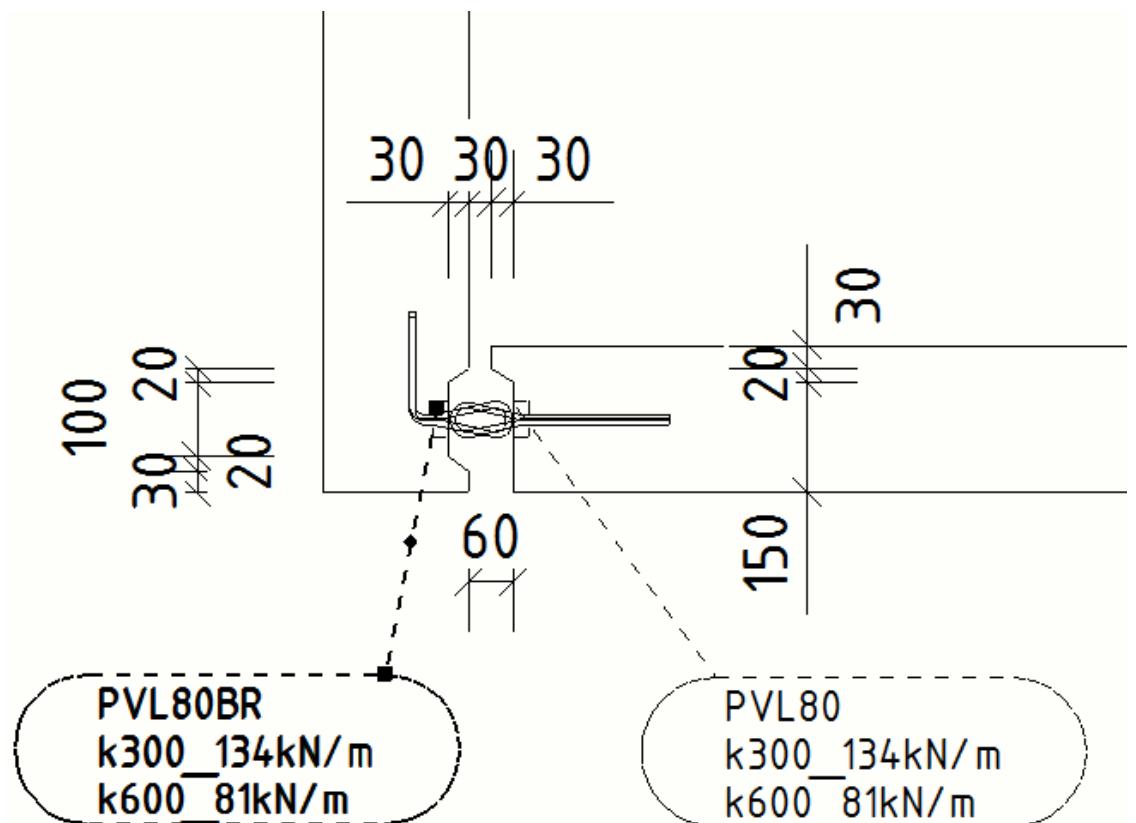

Figure 43 Dimension detail for joint at wall end with PVL®80 and shear resistance (kN/m) when using different spacing (300mm and 600mm)

When it comes to two continuous walls, the connection joint is applied as the setting below given in Figure 44.

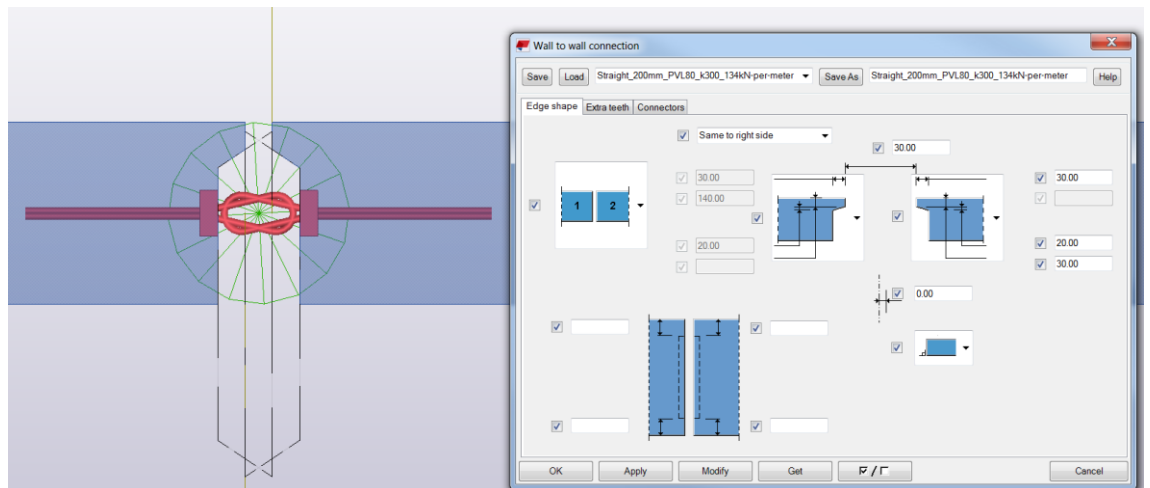

Figure 44 Settings for geometry of the joint using PVL®80 k300

Below in Figure 45 is the dimension detail of the joint when using such type of connection.

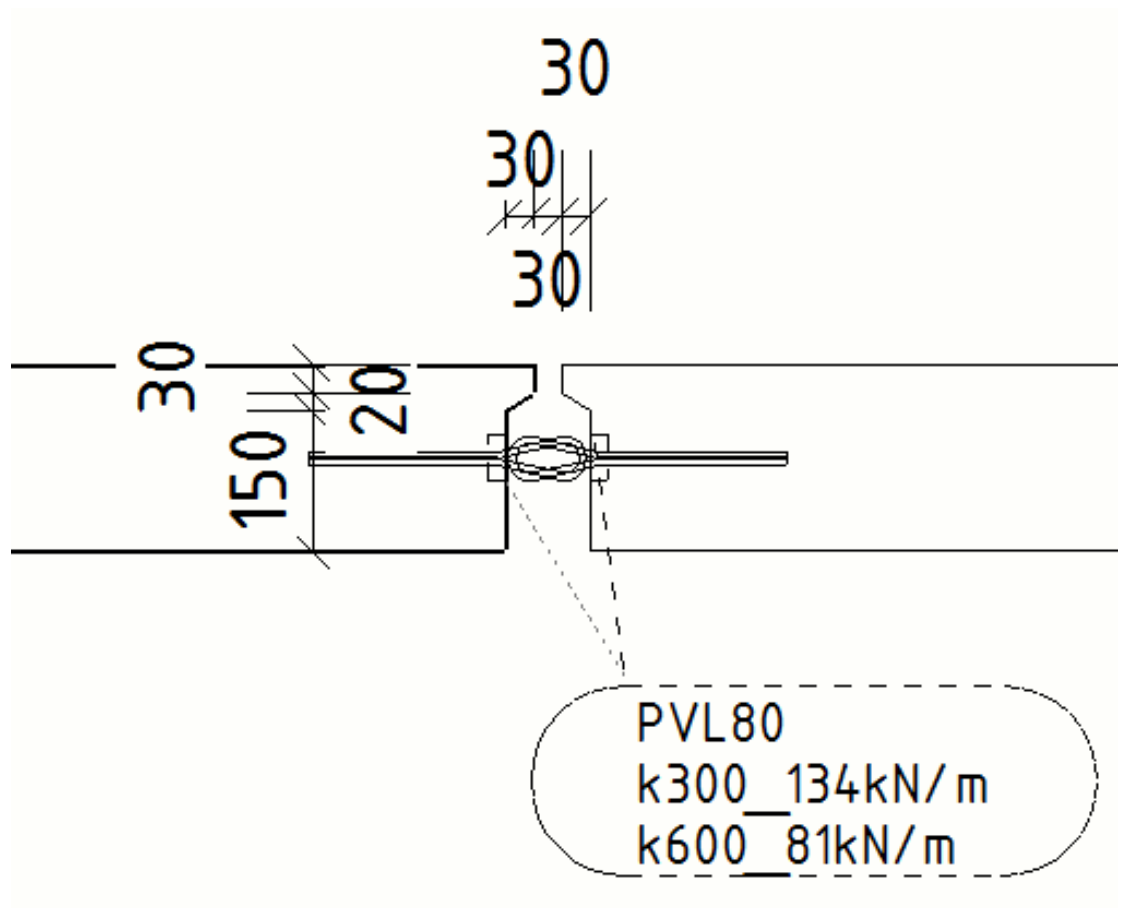

Figure 45 Dimension detail for joint with PVL®80 and shear resistance (kN/m) when using different spacing (300mm and 600mm)

In the matter of two walls connected with each other in the corner, the following settings can be applied as shown in Figure 46.

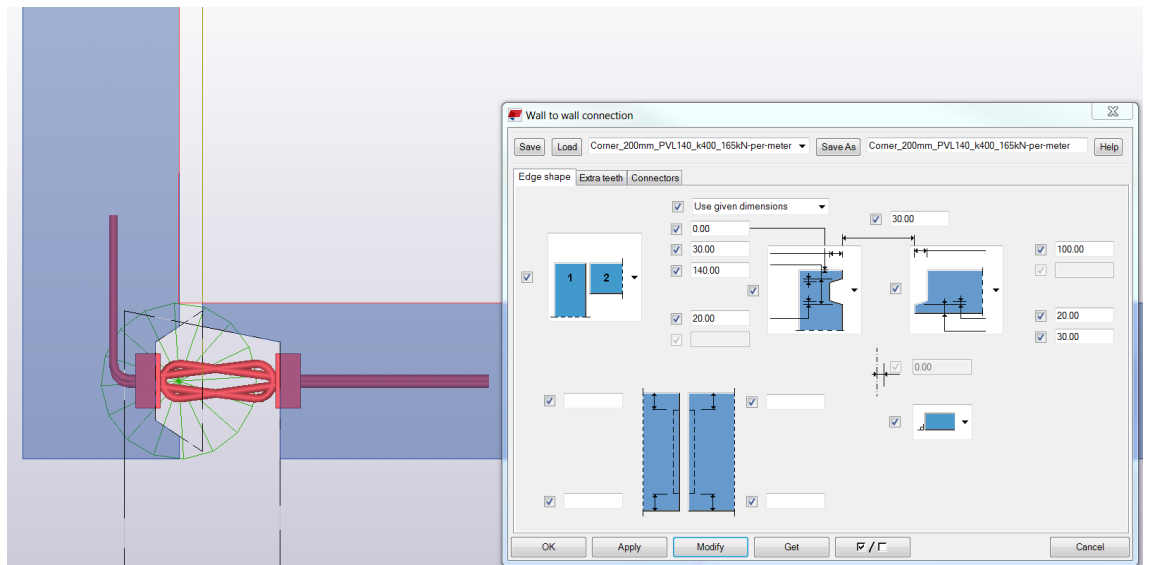

Figure 46: Settings for geometry of the joint at wall end using PVL<sup>®</sup>140. The shear resistance for PVL140 k400 is 165kN/m with C30/37 concrete seam strength (Peikko, 2012, p. 6).

The dimension detail for this connection can be shown as in Figure 47.

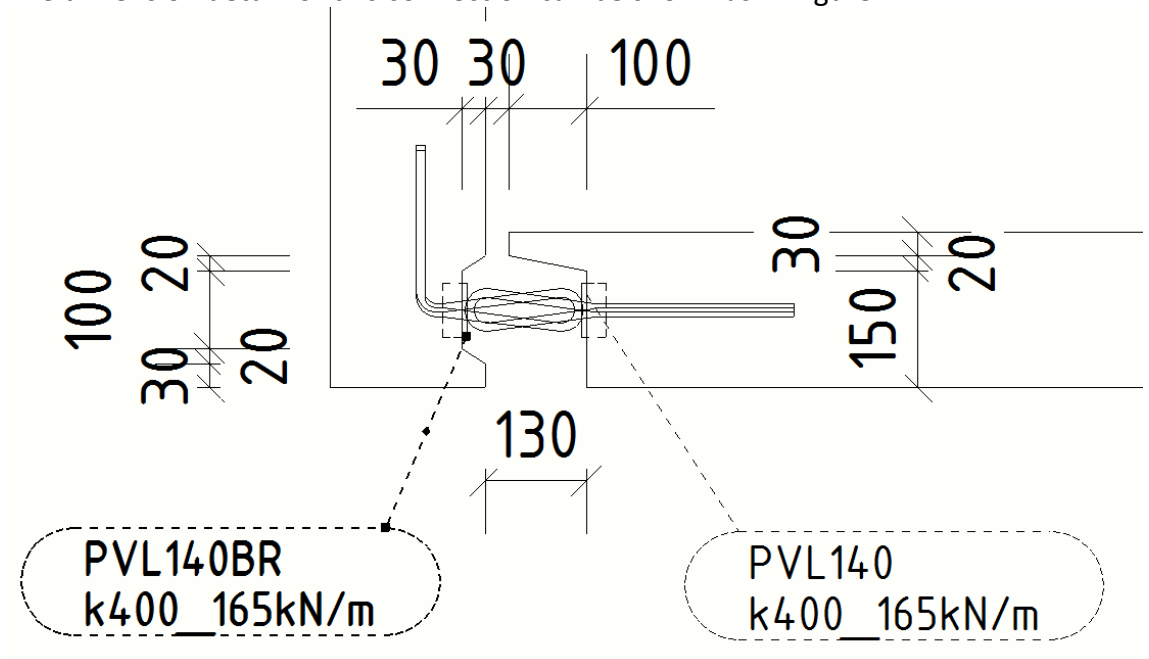

Figure 47: Dimension detail for joint at wall end with PVL<sup>®</sup>140. Shear resistance for PVL140 k400 is 165kN/m.

In this shear core, there is a case when two walls are connected with each other as shown in Figure 48.

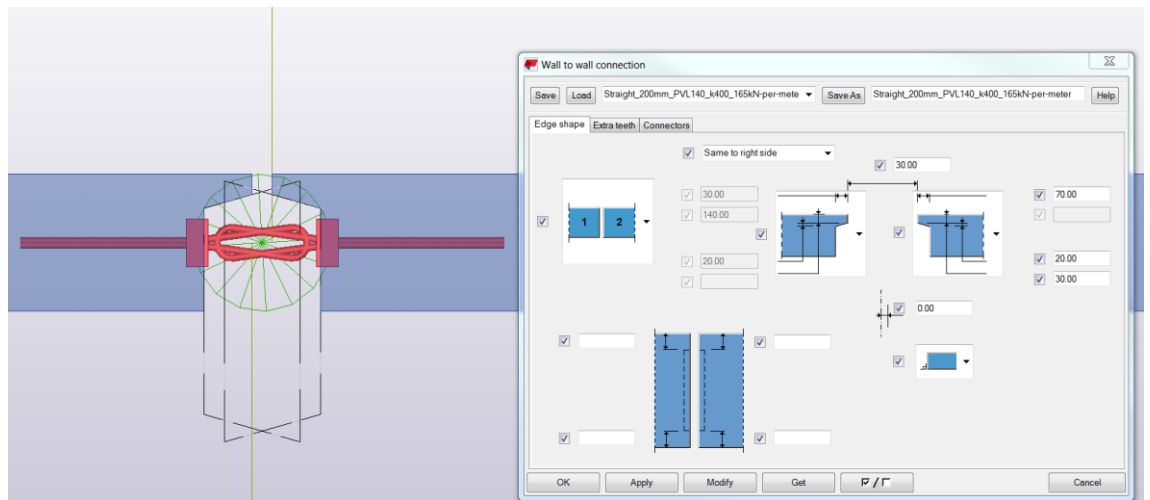

Figure 48 Settings for geometry of the joint using PVL<sup>®</sup>140. Shear resistance for PVL140 k400 is 165kN/m (Peikko, 2012, p. 6).

Below in Figure 49 is the recommended dimension detail for the connection joint based on the setting above.

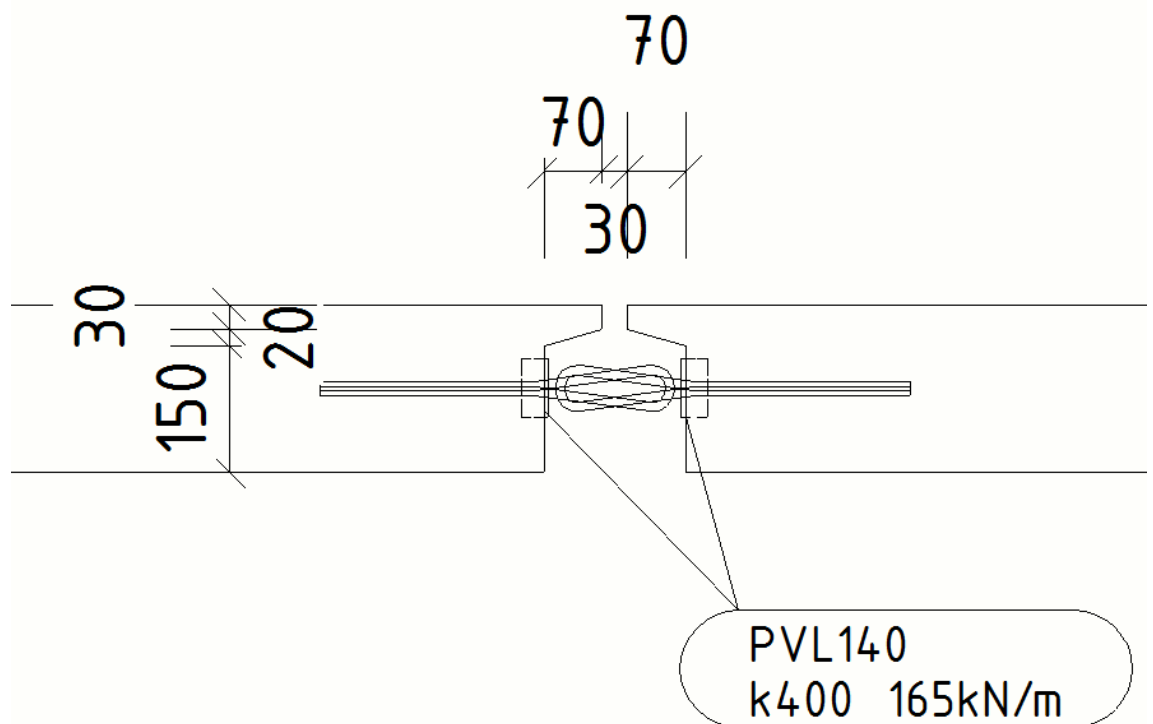

Figure 49 Dimension detail for joint with PVL<sup>®</sup>140. Shear resistance for PVL140 k400 is 165kN/m.

## 6 ON-SITE COMMENTS AND EXPERIENCE

### 6.1 Wire Loops Connection

In this section, the matter of wall assembly on-site will be discussed.

As mentioned in Chapter 3, U-bars are usually bent twice, the first bend is in factory and the last one is on site. This will reduce the strength of steel. On the contrary, wire loop is more flexible and virtually has no bending stiffness. Hence, wire loop connection is easier to use and it is more preferable on site.

There are some certain rules for installing wire loops. The spacing of loops has to be strictly designed according to the manufacturing manual. An example of incorrect spacing is shown in Figure 50.



Figure 50 Loop spacing is bigger than 20mm (Peikko, 2019, p. 26)

Another example of incorrect wire loops installation is the wrong position of loop and short transverse bar, shown in Figure 51.



Figure 51 Incorrect installation of wire loops (Peikko, 2019, p. 26)

The correct position of wire loops can be seen in Figure 52 below.

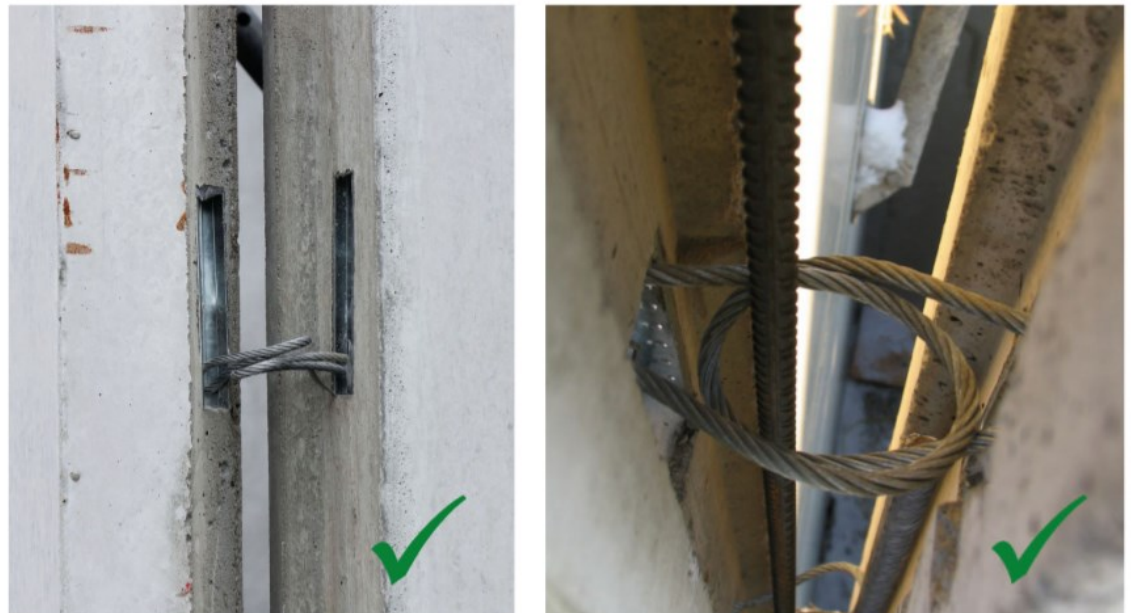

Figure 52 Correct installation of wire loops (Peikko, 2019, p. 26)

Another problem rising from wire loops connection is the geometry of the concrete joint between two wall panels. This affects the concrete seam pouring work.

In case that wire loops have to transfer shear loads perpendicular to the joint as shown in Figure 22 in Chapter 3.3.2, p. 25, the geometry of joint using for such wire loops connection is particularly important.

This joint has to be followed according to manufacturing design manual mentioned in section 5.1.

The concrete joint has to be closed as shown in Figure 22 in Chapter 3.3.2, p. 25. Therefore, it may be difficult when installing wire loops due to narrow zone. Moreover, the seam concrete pouring has to be done on the top of the wall joint as shown in Figure 53.

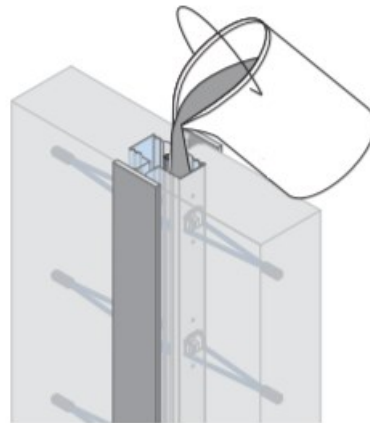

Figure 53 Filling the joint (Halfen, 2016, p. 3)

If the wall joint is designed not to withstand any shear force that is perpendicular to it, the geometry of such joints can be flexibly changed for easier wire loops installation and seam concrete pouring. Since there is no shear force perpendicular to wall joint, the load strut shown in Figure 22 is not needed. Hence, one side of the joint can be opened more widely. Instead of closed joint as recommended in product technical manual, the joint now can be as shown in Figure 54.

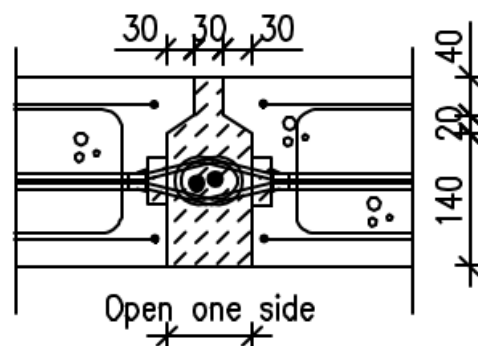

Figure 54 Example of geometry in wall joint

In this case, the concrete seam pouring is easier to process. Figure 55 below shows the process of joint casting.



Figure 55 Casting of the joint (Peikko, 2019, p. 27)

These rules of geometry can be applied for U-bar connection in such cases. Some examples of wall joint can be found in appendix 2.

## 6.2 Heavy duty joint

In fact, if comparing Table 4 with Table 7 and Table 8, provided in Chapter 3, it is clear that U-bars give a better shear resistance. In more detail, according to the same tables, the biggest shear resistance value that U-bars provide is 445,1kN/m, while PVL<sup>®</sup>140 only provides the maximum shear resistance of 209kN/m. Therefore, when dealing with heavy duty joint, U-bars connection is commonly used. However, it is recommended to install two wire loops instead of U-bar for heavy duty joint if possible. Figure 56 shows the heavy duty joint.

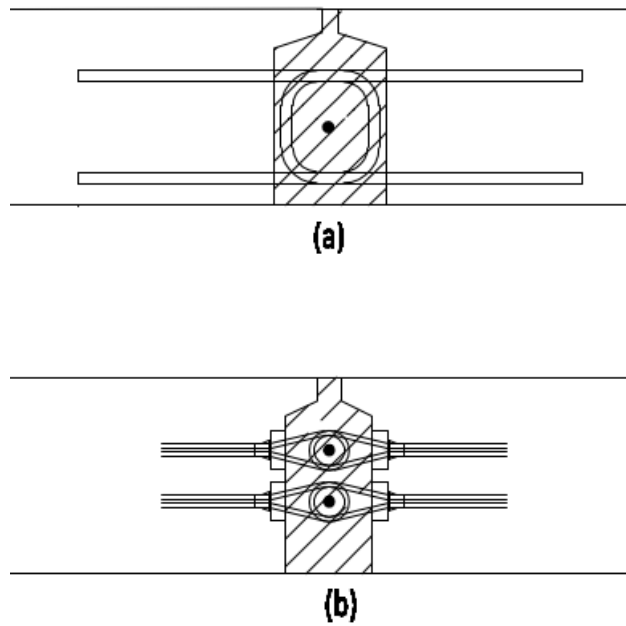

Figure 56 (a) Heavy duty U-bars joint, (b) alternative option for heavy duty joint with two pairs of wire loops

In this option with two pairs of wire loops, the installation is easier compared to U-bars connection.

In the normal case for heavy duty joint, the reinforcement bar is usually U-bars with the diameter larger than 10 – 12 mm. Because of big diameter bars, bending up and manual straightening after installation is not an ideal option. Hence, the wall installation should not be vertical inserting as shown in Figure 57 below due to the fact that pre-bend U-bars will not be used in this case.

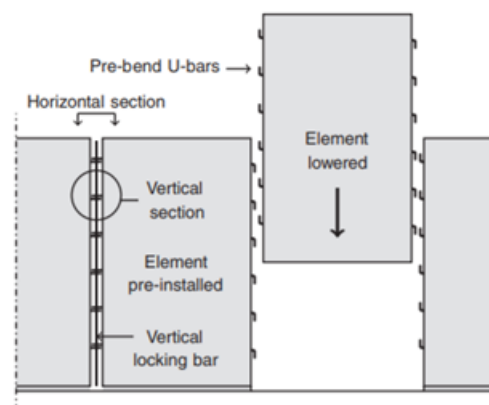

Figure 57 Normal wall installation with U-bars connection (Sørensen, Hoang, Olesen, & Fischer, 2017, p. 190)

To avoid pre-bend U-bars, wall elements are installed horizontally as shown in the Figure 58 below.

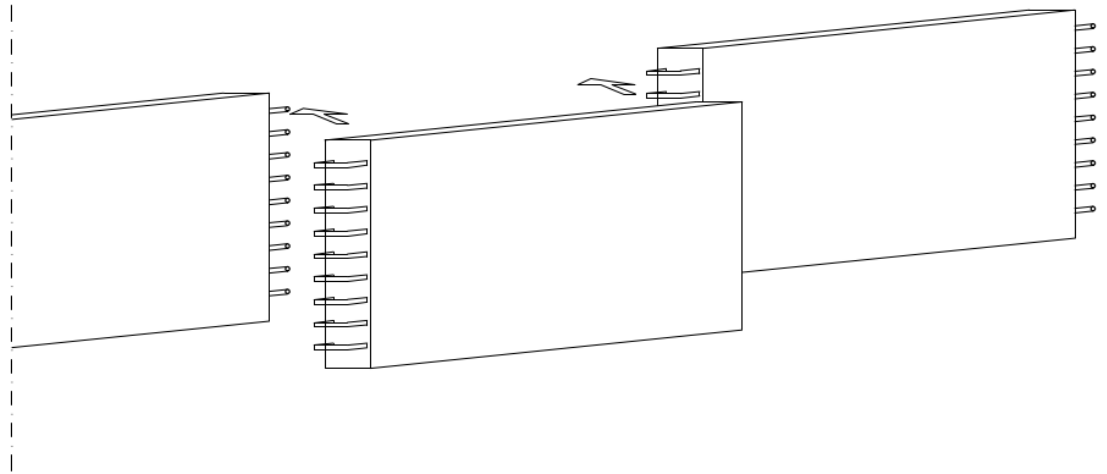

Figure 58: Wall installation for heavy duty case

Many U-bars are normally needed in this case. The spacing of these bars is usually narrow. Therefore, designing U-bars connection regarding spacing and joint geometry is highly precise. The design has to meet the requirement of construction tolerance according to SFS-EN 13670. For concrete construction, the tolerance spacing demanded on this case is  $\pm 10\text{mm}$ .

Some post installed threaded rods that can be used for fully functional wall connection are COPRA® Anchoring Coupler and spiral pipe with rebar. The function of such rods is to transfer tensile, compression, and shear forces through the connection during erection and in the final stage. Anchoring couplers can be designed in order to transfer shear and axial forces, as well as combinations thereof. (Peikko, 2017, pp. 2-4)

## 7 CONCLUSION

In this thesis, shearing force in wall panels was analysed. Different consequence classes were studied to ensure a building with a sufficient robustness to resist a reasonable range of unanticipated accidental actions. Understanding how shear acts in wall joint and choosing the right consequence class for the building, the suitable types of connection in wall shearing joint were made.

Additionally, different types of joints against the shear force in wall was pointed out. The assembling of these joints and adding extra required reinforcement on factory/site were also considered in this thesis. Moreover, some recommend Tekla settings for wall to wall connection using PVL connection were created in order to integrate the studied

connection details into the company's design tools (Tekla Structures) library.

Finally, a practice-based method was applied when it comes to assembling shearing joint of wall on site /factory. Some comments or experience on site was gathered in order to provide the best practice or working solutions.

Therefore, the goals of the thesis work were reached.

## REFERENCES

- BCA. (2001). *Structural Precast Concrete Handbook* (2nd ed.).
- Betoninormikortti 23. (2012). *Liitosten mitoitus onnettomuuskuormille standardin SFS-EN 1991-1-7 yleiset kuormat, onnettomuuskuormat muukaan.*
- Bill, M., John, B., & Ray, H. (2007). *Reinforced Concrete Design to Eurocode 2* (6th ed.).
- BY210. (2005). *Betonirakenteiden suunnittelu ja mitoitus 2005*. Suomen Betoniyhdistys r.y.
- CEB-FIB. (2008). *Structural connections for precast concrete buildings*. International Federation for Structural Concrete.
- Halfen. (2016). *Halfen HLB Loop Box. Technical Product Information*. Retrieved October 12, 2019, from <https://www.halfen.com/en/768/product-ranges/construction/reinforcement-systems/hlb-loop-box/introduction/>
- Jørgensen, H. B. (2014). *Strength of Loop Connections between Precast Concrete Elements*. University of Southern Denmark.
- Liitosten toiminta*. (N.d). Retrieved July 26, 2019, from <https://www.elementtisuunnittelu.fi/fi/liitokset/liitosten-toiminta?term=liitosten%20toiminta>
- Ministry of the Environment. (2016). Strength and stability of structures. In *National Building Code of Finland*.
- Peikko. (2012). *Technical Manual. PVL® Connecting Loop. Wall Connecting Loop Box with Single Wire*. Retrieved September 15, 2018, from <https://www.peikko.com/products/product/pvl-connecting-loop/>
- Peikko. (2017). *COPRA® Anchoring Coupler*. Retrieved December 15, 2019, from <https://www.peikko.com/products/product/copra-anchoring-coupler/>
- Peikko. (2019). *Technical Manual. ARBOX® Joint Reinforcement*. Retrieved December 24, 2019, from <https://www.peikko.com/products/product/arbox/>
- Peikko. (2019). *Technical Manual. PVL® Connecting Loop. Wall Connecting Loop Box with single wire*. Retrieved September 27, 2019, from <https://www.peikko.com/products/product/pvl-connecting-loop/>
- RSteel. (2018). *Technical Manual. RVL Single Wire Loop Box*. Retrieved December 24, 2019, from <https://rsteel.fi/rvl-single-wire-loop-box/>
- SFS-EN 13670. (2009). *Excution of concrete structures*. Helsinki: Finnish Standards Association.

- SFS-EN 1990. (2002). *Eurocode - Basis of structural design*. Helsinki: Finnish Standards Association .
- SFS-EN 1991-1-4. (2005). *Eurocode 1: Actions on structures - Part 1-4: General actions - Wind actions*. Helsinki: Finnish Standards Association .
- SFS-EN 1991-1-7. (2006). *Eurocode 1 - Actions on structures - Part 1-7: General actions - Accidental actions*. Helsinki: Finnish Standards Association .
- SFS-EN 1992-1-1. (2004). *Eurocode 2: Design of concrete structures - Part 1-1: General rules and rules for buildings*. Helsinki: Finnish Standards Association .
- Sørensen, J., Hoang, L., Olesen, J., & Fischer, G. (2017). *Test and analysis of a new ductile shear connection design for RC shear walls*. Retrieved April 13, 2019, from <https://doi.org/10.1002/suco.201600056>

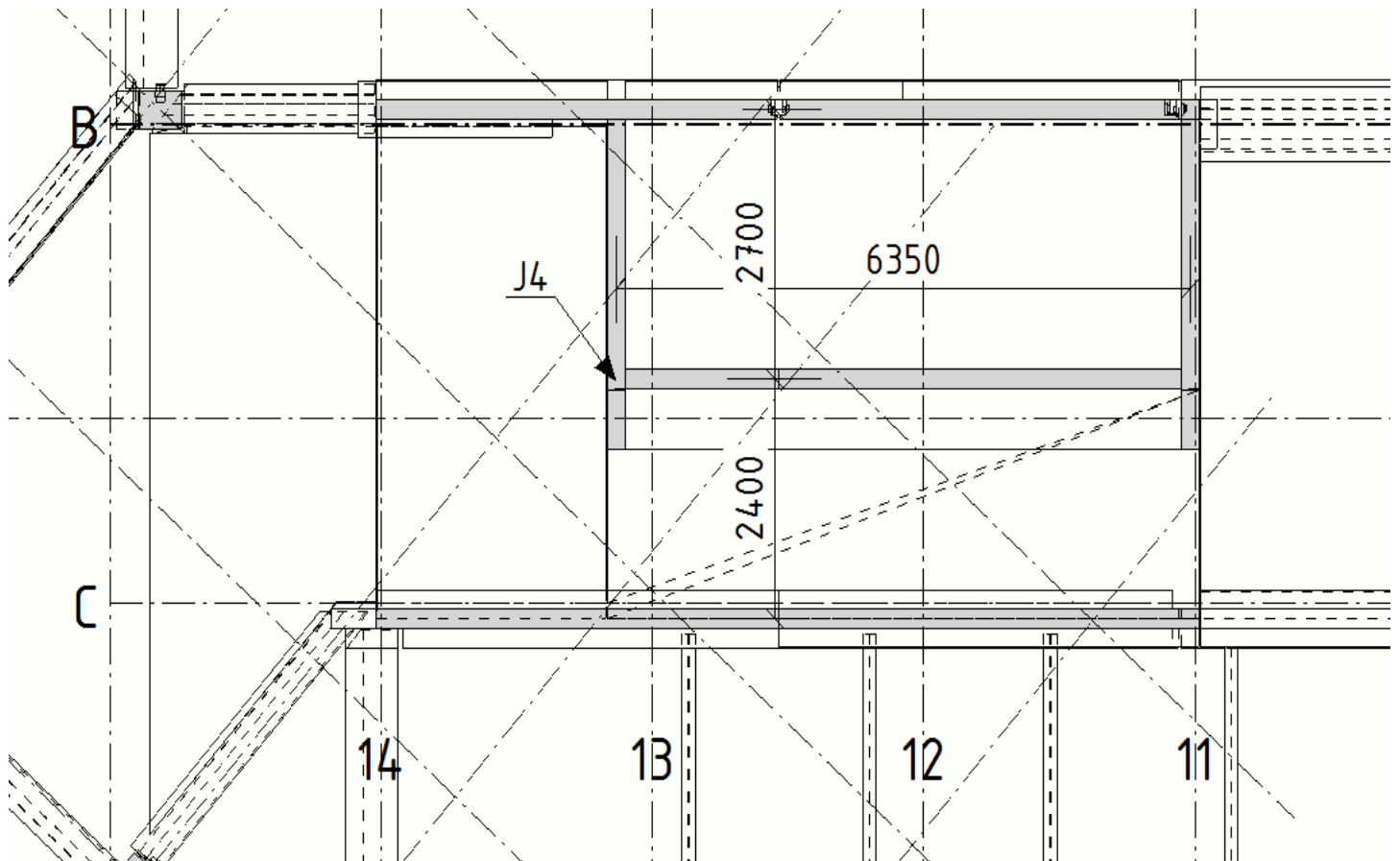

Wall vertical seam reinforcement

$$f_y := 500 \text{ MPa}$$

$$f_{ck} := 25 \text{ MPa}$$

$$\gamma_c := 1.2$$

$$L1 := 2.7 \text{ m}$$

$$L2 := 2.4 \text{ m}$$

$$Ls1 := 6.35 \text{ m}$$

$$S1 := \frac{(L1 + L2)}{2} = 2.55 \text{ m}$$

J9:

$$L := S1 = 2.55 \text{ m}$$

$$B1 := Ls1 = 6.35 \text{ m}$$

$$A := L \cdot B1 = 16.193 \text{ m}^2$$

Accumulation width between wall elements

The length of the wall element

Accumulation Area

$$g_k := 5.75 \frac{\text{kN}}{\text{m}^2} \quad q_k := 3 \frac{\text{kN}}{\text{m}^2}$$

$$g_{ks} := 25 \frac{\text{kN}}{\text{m}^3} \cdot 0.2 \text{ m} \cdot (3.6 \text{ m} - 0.4 \text{ m}) = 16 \frac{\text{kN}}{\text{m}}$$

Metric weight of the wall element

$$\begin{aligned}
 Gks1 &:= gks \cdot B1 = 101.6 \text{ kN} && \text{Weight of wall element} \\
 Fvtot1 &:= Gks1 + A \cdot (gk + qk) = 243.284 \text{ kN} && \text{Total suspension load} \\
 Fv1 &:= \frac{Fvtot1}{2} = 121.642 \text{ kN} && \text{Suspension load / vertical seam} \\
 Asf1 &:= \frac{Fv1}{fy} = 243.284 \text{ mm}^2 && \text{Required vertical seam reinforcement area} \\
 \text{Use } & \mathbf{1T12+1T16} && As.tot := \left( (6 \text{ mm})^2 + (8 \text{ mm})^2 \right) \cdot \pi = 314.159 \text{ mm}^2
 \end{aligned}$$

### Wall seam reinforcement

$$L4 := 6.35 \text{ m}$$

Bonding forces:

$$S4 := \left( \frac{L4}{2} \right) = 3.175 \text{ m}$$

The tie forces:

$$T_0 := 20 \frac{\text{kN}}{\text{m}}, \text{ when } gk \geq 3.0 \frac{\text{kN}}{\text{m}^2}$$

$$Tsi := S \cdot T_0$$

$$Ts4 := T_0 \cdot S4 = 63.5 \text{ kN}$$

$$70 \text{ kN} \leq T \leq 150 \text{ kN}$$

Tie force limitations when CC2b

$$T4 \quad Assreq := \frac{70 \text{ kN}}{fy} = 140 \text{ mm}^2 \quad \text{Required amount of steel}$$

---> Use 2T12

$$Ass.tot := 2 \cdot (6 \text{ mm})^2 \cdot \pi = 226.195 \text{ mm}^2 \quad Ass.tot \geq Assreq \quad \text{OK}$$

### Seam reinforcement drawing

1:100

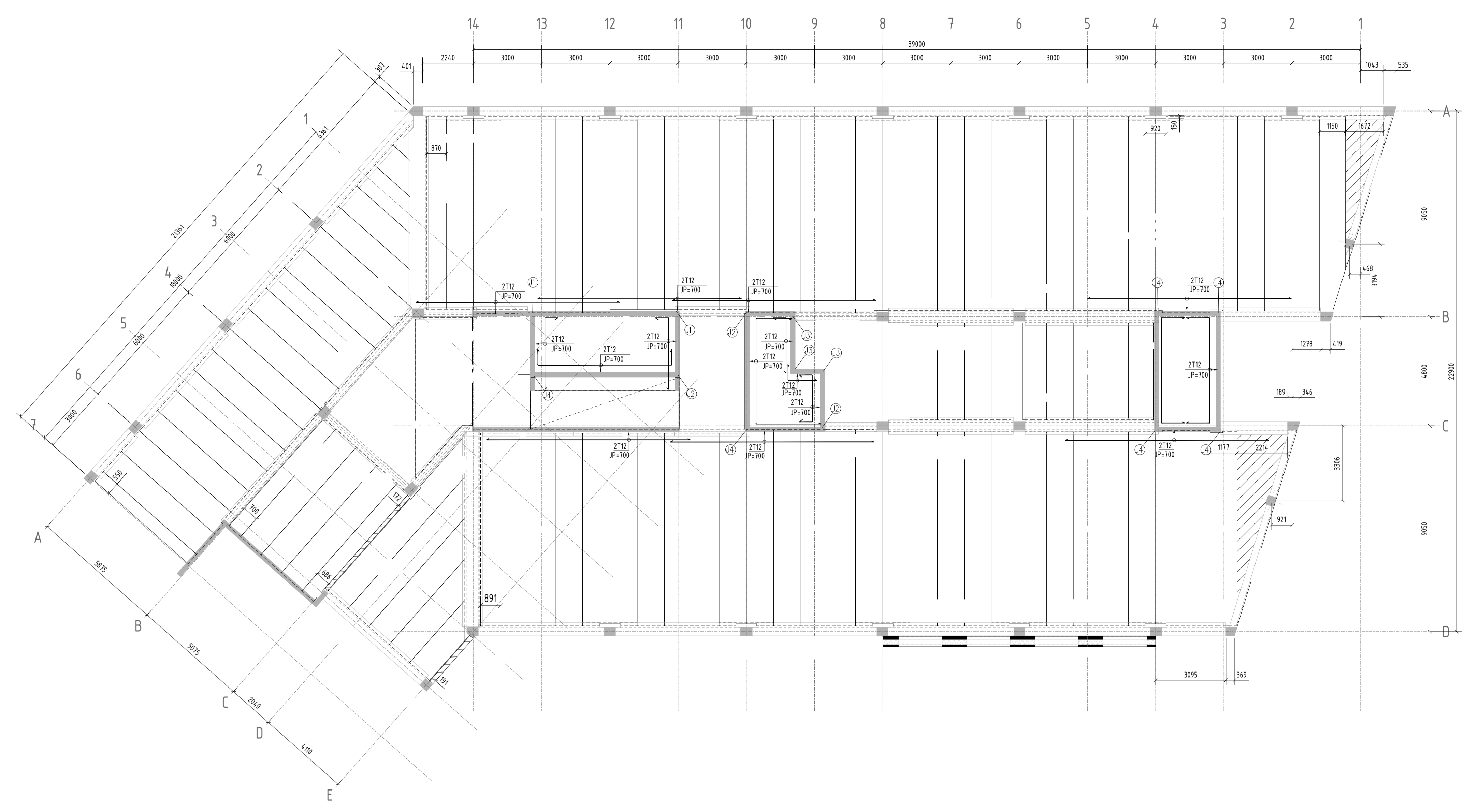

STRUCTURAL DESIGN	LIFETIME:	50 YEARS
FIRE CLASS:	FIRE CLASS	P1
OTHERWISE SPECIFIED	LOAD STRUCTURES	R60, UNLESS
TOLERANCES:	NORMAALILUOKKA(BY47-2013)	
ELEMENT:	TOLERANCES FOR CONCRETE ELEMENTS SFS-EN 13670 UNLESS THE ELEMENTAL DESCRIPTION OTHERWISE SPECIFIED	
STEEL STRUCTURES:	ACCORDING TO STANDARD SFS EN 1090-2	
LOAD CATEGORIES:	XC1 INTERIORS	
	XC3,3, XD1, XF1 EXTERNAL STRUCTURES, EXTERIOR COVER FOR THE FACADE	
CONCRETE:	INTERIORS:	C30 / 37, ALSO SEAM, UNLESS OTHERWISE SPECIFIED
	EXTERIORS:	C32/40, UNLESS OTHERWISE SPECIFIED
	ELEMENT STRUCTURES:	ACCORDING TO SPECIAL DRAWINGS
	MAX. RAEKOKO:	15mm, SEAM AREA 8mm
	CONCRETE COVER INTERIOR:	20mm, UNLESS OTHERWISE SPECIFIED, PERMISSIBLE 10mm
	CONCRETE COVER EXTERIOR:	35mm, UNLESS OTHERWISE SPECIFIED, PERMISSIBLE 10mm
CONCRETE REINFORCEMENT:	T=A500HW OR B500B WELDING (SFS1215 OR SFS1269)	
	K = B500A NETWORKS (SFS1257)	
	E = B600KX STAINLESS STEEL (SFS 1259)	
	g = PERMANENT LOAD	q = IMPOSED LOAD
LOADS:		
CONSEQUENCES CLASS	CC2B	
IMPLEMENTATION CLASS	2	
SLAB:	HOLLOW SLAB	HI = 370 UNLESS OTHERWISE SPECIFIED, 037 / 037K
	HOLLOW SLAB	HI = 265 UNLESS OTHERWISE SPECIFIED, 027 / 27K
	DESIGNED SUPPORT SURFACE:	037, 60mm ON WALL
		027, 60mm ON WALL
DO NOT EXCEED 2 ELECTRICAL TUBES D20 / JOIN IN LONGITUDINALLY SEALED SHEETS		
NO MORE THAN 3 ELECTRIC TUBES MAY BE CARRIED OUT IN THE SEALING AND INTERMEDIATE SEALS OF CAVED TILES		
D20		
STRUCTURAL STEELS:	PIPE PROFILES	S355J2H
	SHAPED STEELS	S235JRG2, S355J2G2, S355J2G4
	WELDING CLASS C (SFS-EN ISO 5817)	
WELDING: SMOOTH WELDING ABOUT AND / OR MORE THAN WALL WALL UNLESS OTHERWISE SPECIFIED		
OUTSIDE CORROSION PROTECTION: HOT DIP Galvanizing 70 µm EXPOSURE CLASS M3		

### VERTICAL REINFORCEMENT

1:50

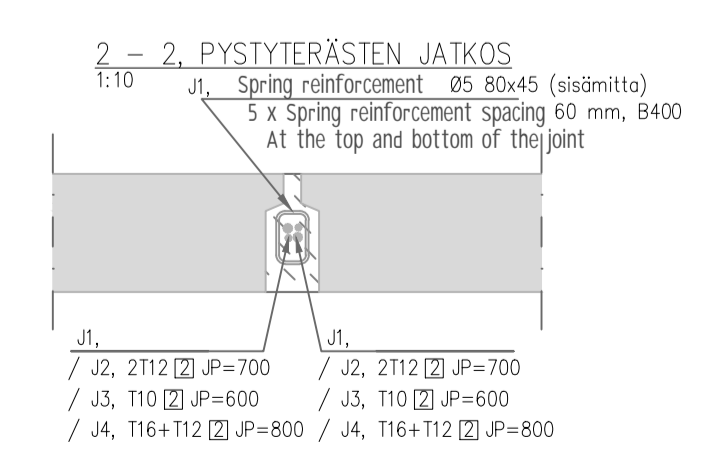
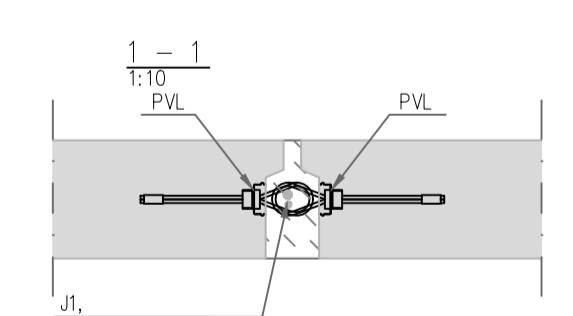
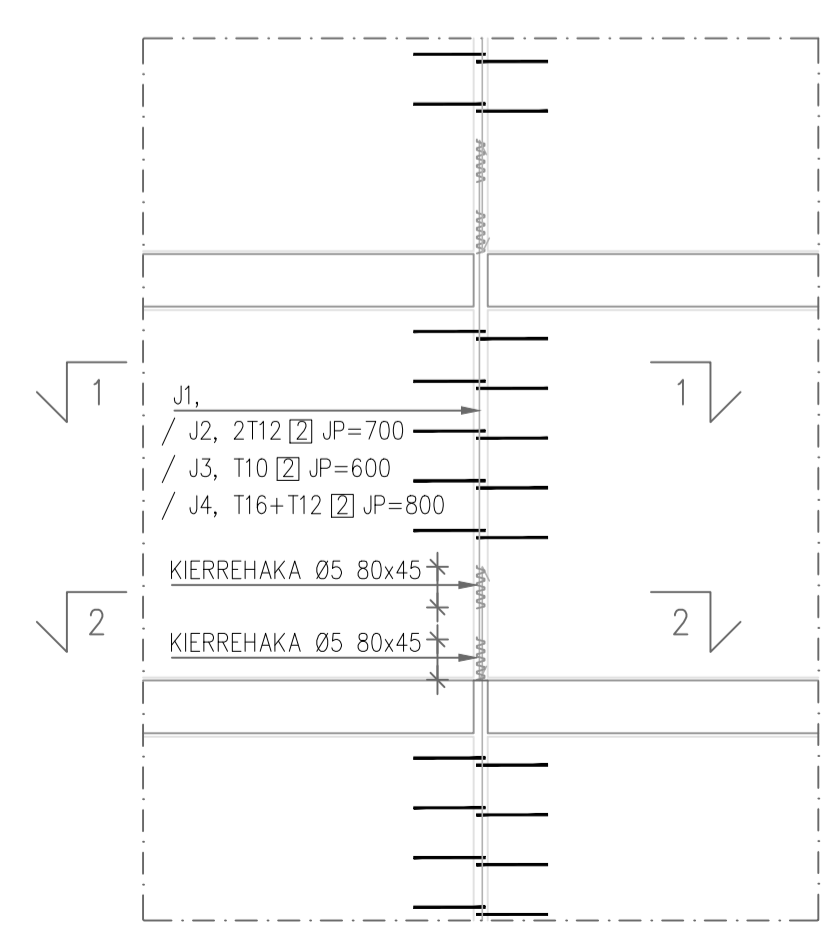

Revisio	Km.	Muutos	KORTTELI/TILA	TOKI/TI/ANNO	IRANOMASTER ARHISTORIKONTIUKA VARTEN	RAKU	Task.	Hyy.
RAKENNUSNUMERO / RAKENNUS								
RAKENNUSMÄÄRÄ								
VASTAAVA RAKENNUSMÄÄRITTEIJÄ								
KOHDE			IRANOMASTERIN SEKALTO					
			2nd - 8th FLOOR					
			SEAM REINFORCEMENT					
PIRTTILÄ			PM					
TARK.			HYY.					
			SUUNNITTELUALA	TYÖNUMERO				
			RAK	PIR.NRO				

<h1 style="margin: 0;">SANDWICH ELEMENT CONNECTION</h1>	<h2 style="margin: 0;">1:10</h2>
---	----------------------------------

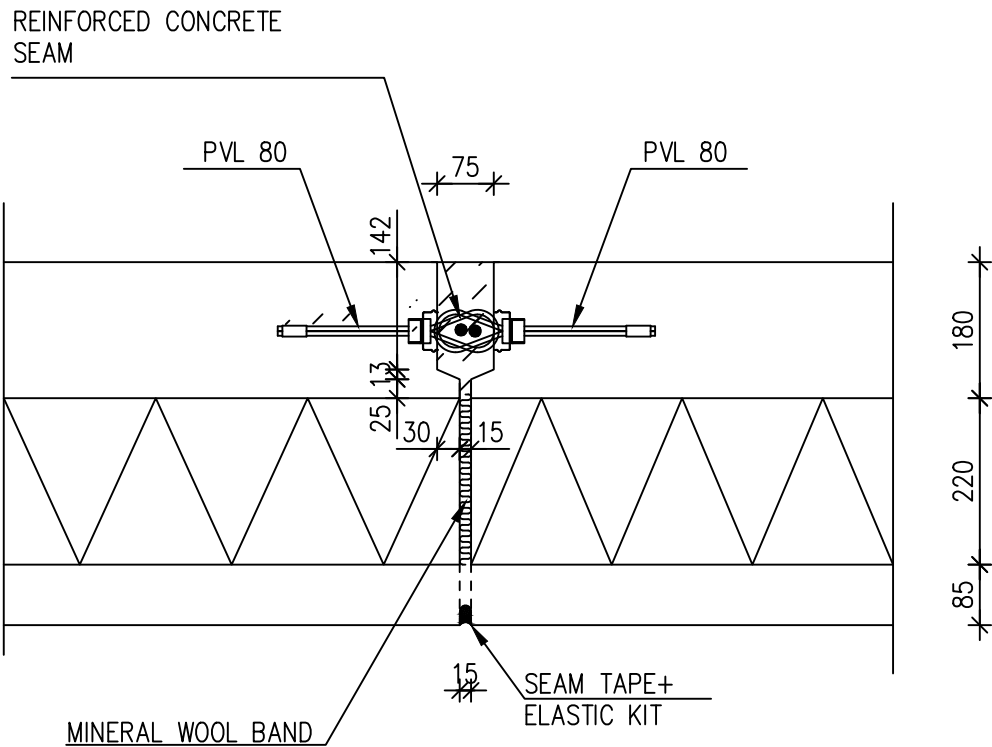

Design Shear resistance  $V_{Rd}$ (kN/m) of PVL 60, PVL80, PVL 100, PVL 120 Wire Loop

Concrete strength (EC 2)	Spacing of loops (mm)										
	250	300	350	400	450	500	550	600	650	700	750
C25/30	153	132	116	105	96	89	83	78	74	70	67
C30/37	156	134	119	107	99	91	86	81	77	73	70
C35/45	158	137	122	110	101	94	88	83	79	76	73

Design Shear resistance  $V_{Rd}$ (kN/m) of PVL 140 Wire Loop

Concrete strength (EC 2)	Spacing of loops (mm)							
	350	400	450	500	550	600	650	700
C25/30	170	153	137	123	112	103	96	90
C30/37	185	165	148	134	121	111	103	97
C35/45	197	177	158	143	130	119	110	103

SANDWICH ELEMENT  
CORNER CONNECTION

1:10

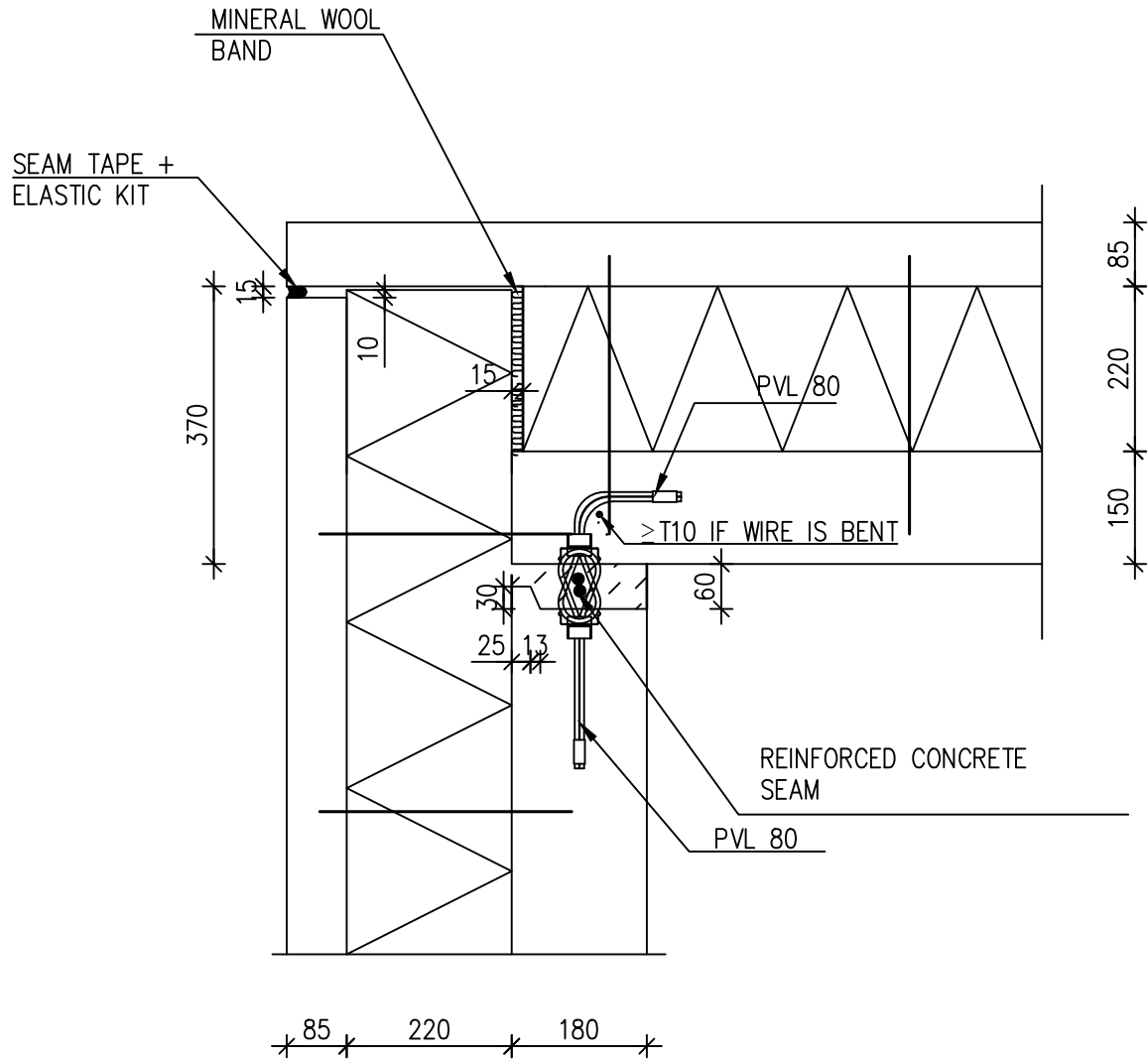

Design Shear resistance  $V_{Rd}$ (kN/m) of PVL 60, PVL 80, PVL 100, PVL 120 Wire Loop

Concrete strength (EC 2)	Spacing of loops (mm)										
	250	300	350	400	450	500	550	600	650	700	750
C25/30	153	132	116	105	96	89	83	78	74	70	67
C30/37	156	134	119	107	99	91	86	81	77	73	70
C35/45	158	137	122	110	101	94	88	83	79	76	73

Design Shear resistance  $V_{Rd}$ (kN/m) of PVL 140 Wire Loop

Concrete strength (EC 2)	Spacing of loops (mm)							
	350	400	450	500	550	600	650	700
C25/30	170	153	137	123	112	103	96	90
C30/37	185	165	148	134	121	111	103	97
C35/45	197	177	158	143	130	119	110	103

CONNECTION OF SANDWICH ELEMENT AND PARTITION

1:10

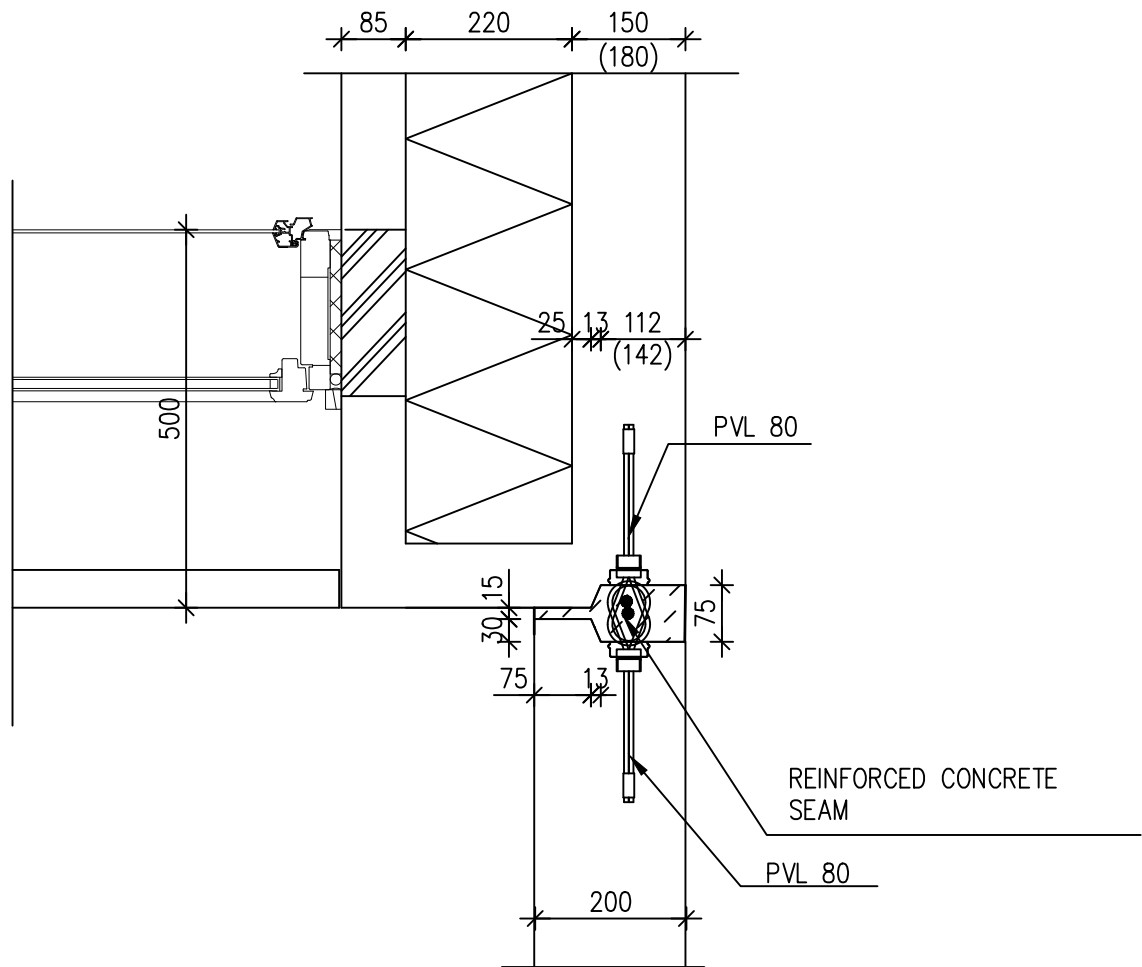

Design Shear resistance  $V_{Rd}$ (kN/m) of PVL 60, PVL 80, PVL 100, PVL 120 Wire Loop

Concrete strength (EC 2)	Spacing of loops (mm)										
	250	300	350	400	450	500	550	600	650	700	750
C25/30	153	132	116	105	96	89	83	78	74	70	67
C30/37	156	134	119	107	99	91	86	81	77	73	70
C35/45	158	137	122	110	101	94	88	83	79	76	73

Design Shear resistance  $V_{Rd}$ (kN/m) of PVL 140 Wire Loop

Concrete strength (EC 2)	Spacing of loops (mm)							
	350	400	450	500	550	600	650	700
C25/30	170	153	137	123	112	103	96	90
C30/37	185	165	148	134	121	111	103	97
C35/45	197	177	158	143	130	119	110	103

SANDWICH ELEMENT  
CORNER CONNECTION

1:10

REINFORCED CONCRETE  
SEAM

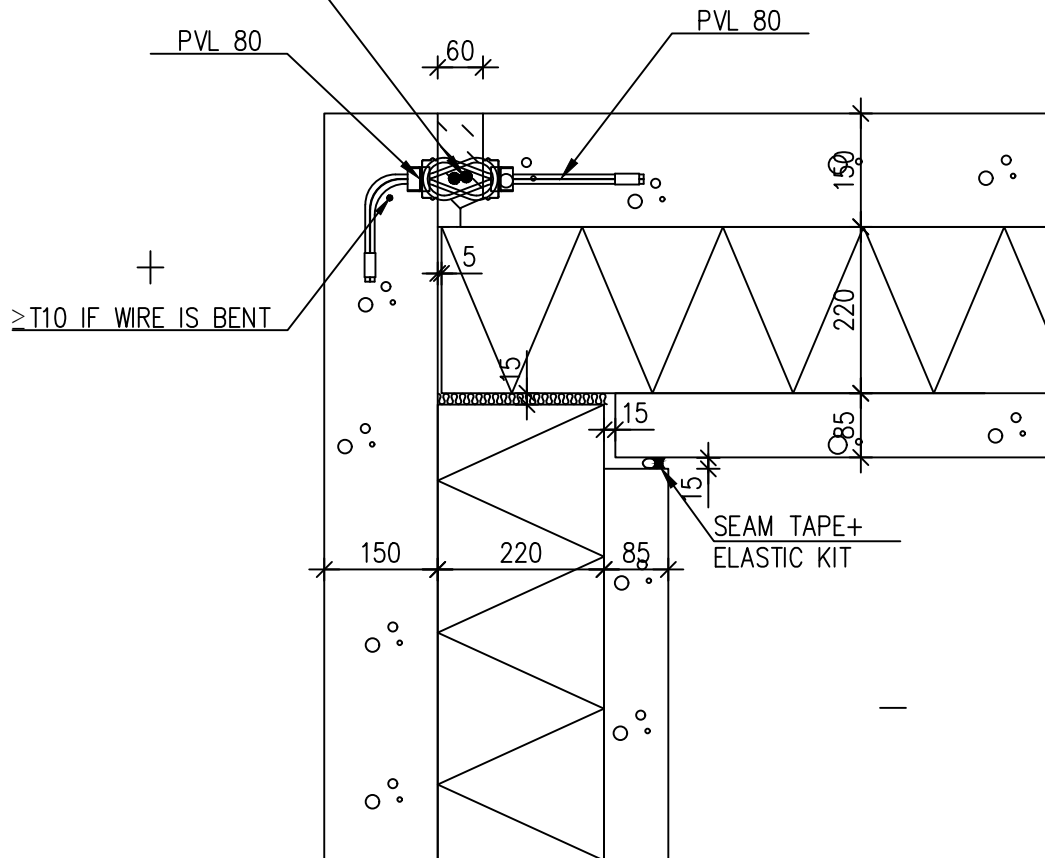

Design Shear resistance  $V_{Rd}$ (kN/m) of PVL 60, PVL80, PVL 100, PVL 120 Wire Loop

Concrete strength (EC 2)	Spacing of loops (mm)										
	250	300	350	400	450	500	550	600	650	700	750
C25/30	153	132	116	105	96	89	83	78	74	70	67
C30/37	156	134	119	107	99	91	86	81	77	73	70
C35/45	158	137	122	110	101	94	88	83	79	76	73

Design Shear resistance  $V_{Rd}$ (kN/m) of PVL 140 Wire Loop

Concrete strength (EC 2)	Spacing of loops (mm)							
	350	400	450	500	550	600	650	700
C25/30	170	153	137	123	112	103	96	90
C30/37	185	165	148	134	121	111	103	97
C35/45	197	177	158	143	130	119	110	103

CONNECTION OF SANDWICH  
ELEMENT AND AIR-RAID  
SHELTER WALL

1:10

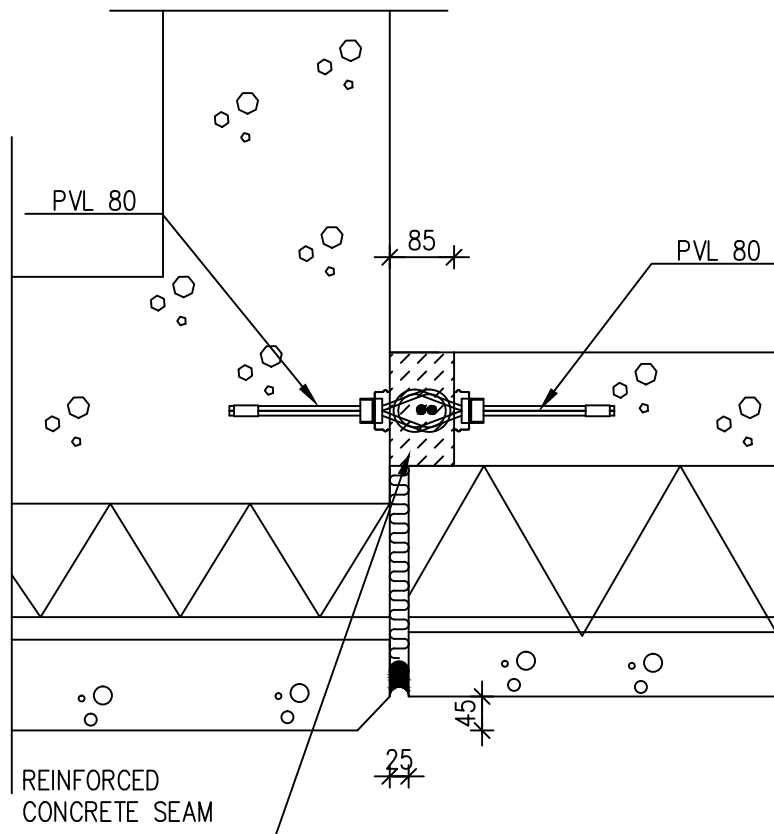

Design Shear resistance  $V_{Rd}$ (kN/m) of PVL 60, PVL80, PVL 100, PVL 120 Wire Loop

Concrete strength (EC 2)	Spacing of loops (mm)										
	250	300	350	400	450	500	550	600	650	700	750
C25/30	153	132	116	105	96	89	83	78	74	70	67
C30/37	156	134	119	107	99	91	86	81	77	73	70
C35/45	158	137	122	110	101	94	88	83	79	76	73

Design Shear resistance  $V_{Rd}$ (kN/m) of PVL 140 Wire Loop

Concrete strength (EC 2)	Spacing of loops (mm)							
	350	400	450	500	550	600	650	700
C25/30	170	153	137	123	112	103	96	90
C30/37	185	165	148	134	121	111	103	97
C35/45	197	177	158	143	130	119	110	103

WALL ELEMENT  
CONNECTION

1:10

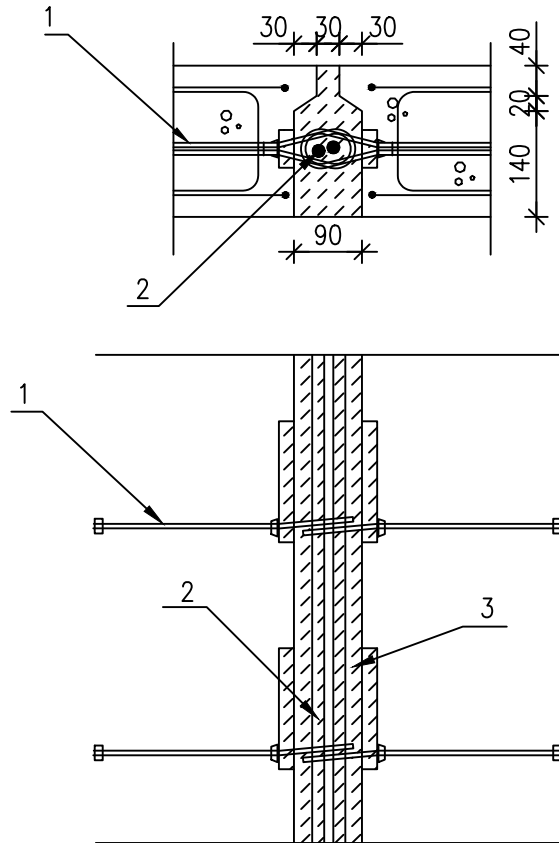

- 1 Wire loops, according to the designer's instructions
- 2 Vertical seam steel, according to seam reinforcement drawing
- 3 Concrete seam

Design Shear resistance  $V_{Rd}$ (kN/m) of PVL 60, PVL 80, PVL 100, PVL 120 Wire Loop

Concrete strength (EC 2)	Spacing of loops (mm)										
	250	300	350	400	450	500	550	600	650	700	750
C25/30	153	132	116	105	96	89	83	78	74	70	67
C30/37	156	134	119	107	99	91	86	81	77	73	70
C35/45	158	137	122	110	101	94	88	83	79	76	73

Design Shear resistance  $V_{Rd}$ (kN/m) of PVL 140 Wire Loop

Concrete strength (EC 2)	Spacing of loops (mm)							
	350	400	450	500	550	600	650	700
C25/30	170	153	137	123	112	103	96	90
C30/37	185	165	148	134	121	111	103	97
C35/45	197	177	158	143	130	119	110	103

WALL ELEMENT  
CORNER CONNECTION

1:10

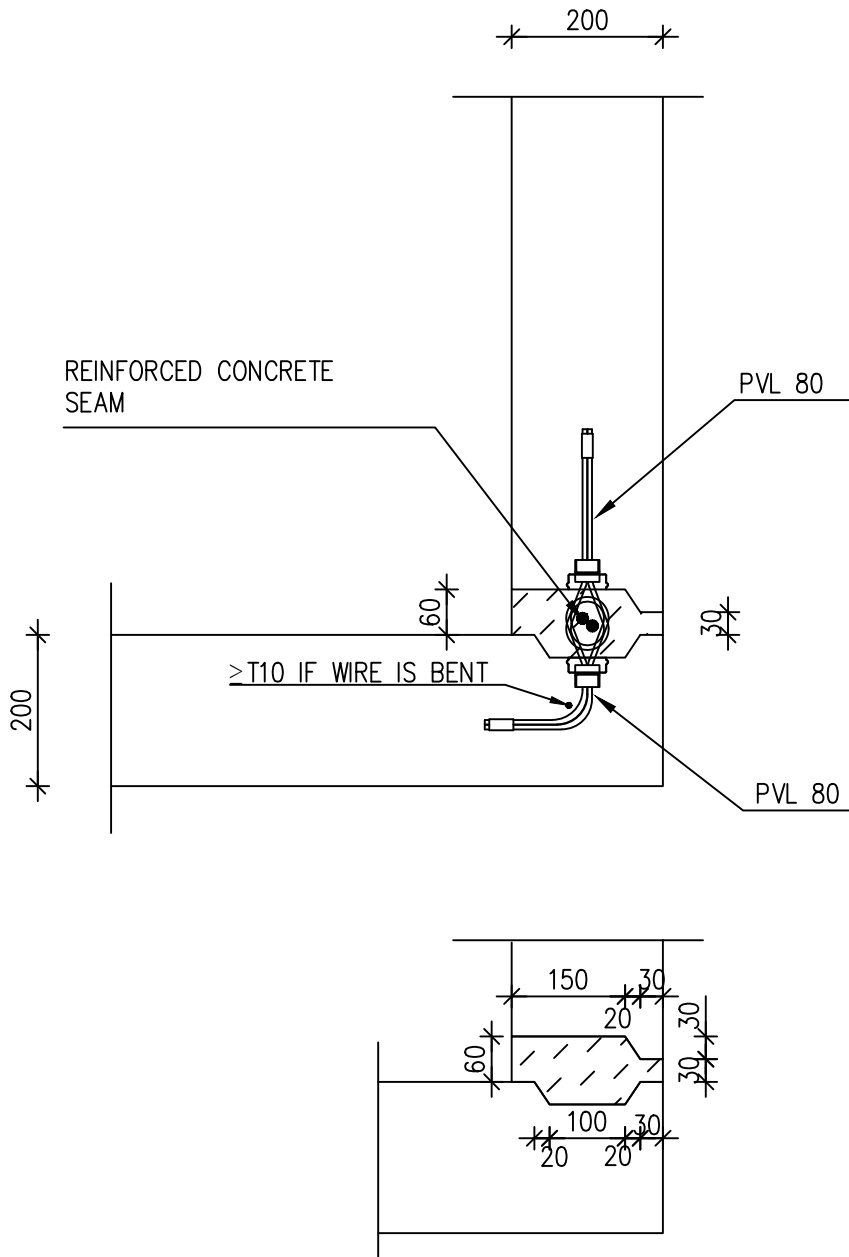

Design Shear resistance  $V_{Rd}$ (kN/m) of PVL 60, PVL 80, PVL 100, PVL 120 Wire Loop

Concrete strength (EC 2)	Spacing of loops (mm)										
	250	300	350	400	450	500	550	600	650	700	750
C25/30	153	132	116	105	96	89	83	78	74	70	67
C30/37	156	134	119	107	99	91	86	81	77	73	70
C35/45	158	137	122	110	101	94	88	83	79	76	73

Design Shear resistance  $V_{Rd}$ (kN/m) of PVL 140 Wire Loop

Concrete strength (EC 2)	Spacing of loops (mm)							
	350	400	450	500	550	600	650	700
C25/30	170	153	137	123	112	103	96	90
C30/37	185	165	148	134	121	111	103	97
C35/45	197	177	158	143	130	119	110	103



WALL ELEMENT  
CONNECTION

1:10

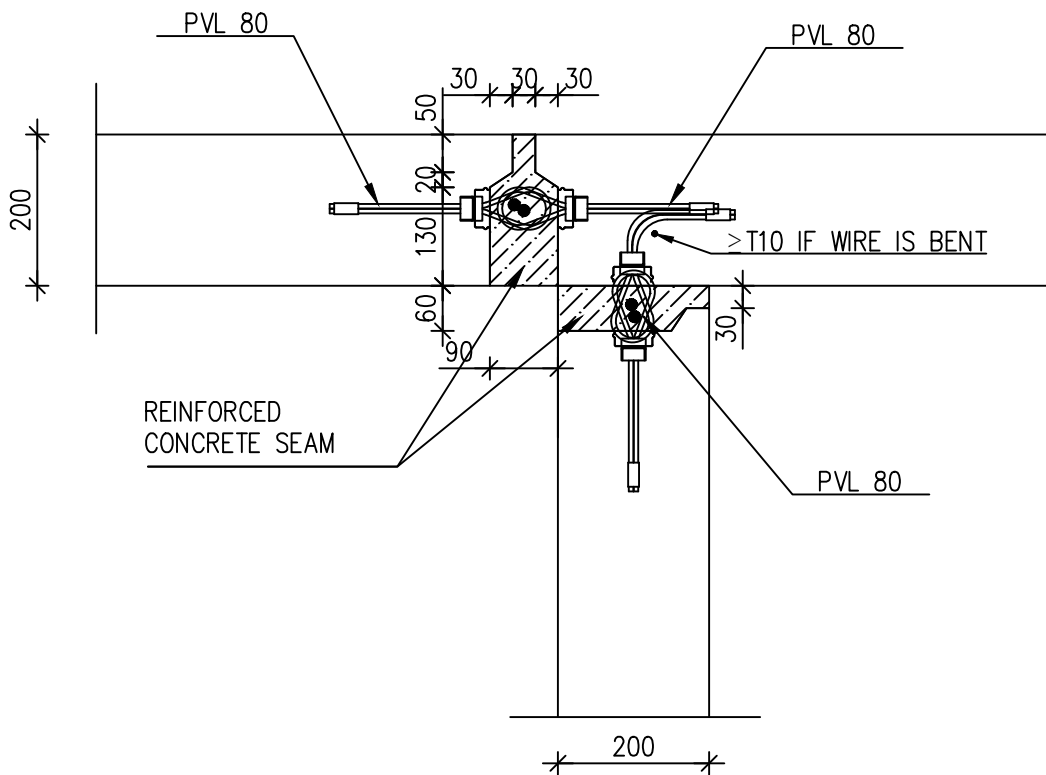

Design Shear resistance  $V_{Rd}$ (kN/m) of PVL 60, PVL 80, PVL 100, PVL 120 Wire Loop

Concrete strength (EC 2)	Spacing of loops (mm)										
	250	300	350	400	450	500	550	600	650	700	750
C25/30	153	132	116	105	96	89	83	78	74	70	67
C30/37	156	134	119	107	99	91	86	81	77	73	70
C35/45	158	137	122	110	101	94	88	83	79	76	73

Design Shear resistance  $V_{Rd}$ (kN/m) of PVL 140 Wire Loop

Concrete strength (EC 2)	Spacing of loops (mm)							
	350	400	450	500	550	600	650	700
C25/30	170	153	137	123	112	103	96	90
C30/37	185	165	148	134	121	111	103	97
C35/45	197	177	158	143	130	119	110	103

WALL ELEMENT CONNECTION

1:10

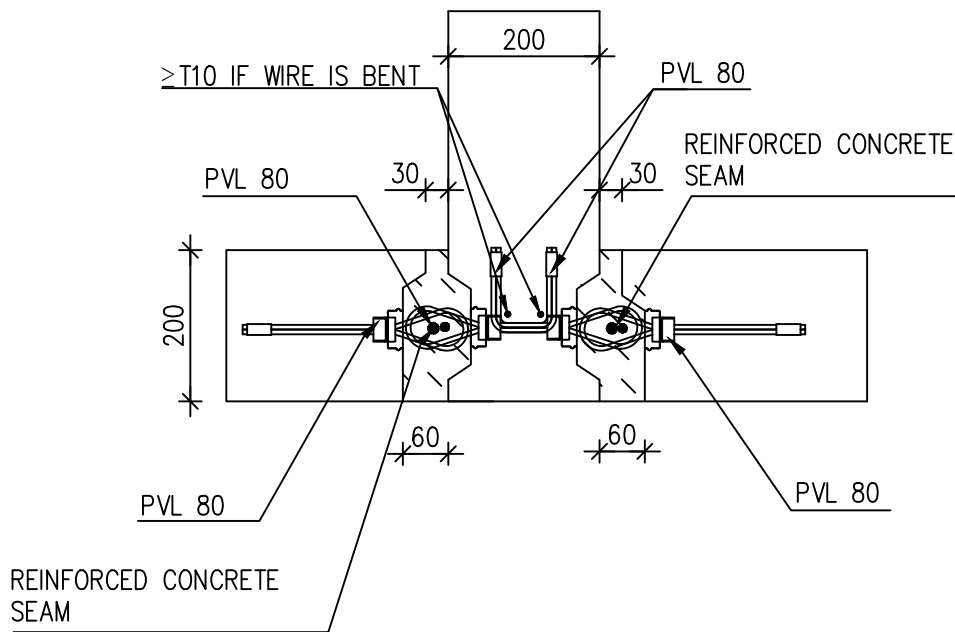

Design Shear resistance  $V_{Rd}$ (kN/m) of PVL 60, PVL80, PVL 100, PVL 120 Wire Loop

Concrete strength (EC 2)	Spacing of loops (mm)										
	250	300	350	400	450	500	550	600	650	700	750
C25/30	153	132	116	105	96	89	83	78	74	70	67
C30/37	156	134	119	107	99	91	86	81	77	73	70
C35/45	158	137	122	110	101	94	88	83	79	76	73

Design Shear resistance  $V_{Rd}$ (kN/m) of PVL 140 Wire Loop

Concrete strength (EC 2)	Spacing of loops (mm)							
	350	400	450	500	550	600	650	700
C25/30	170	153	137	123	112	103	96	90
C30/37	185	165	148	134	121	111	103	97
C35/45	197	177	158	143	130	119	110	103

WALL ELEMENT  
CONNECTION

1:10

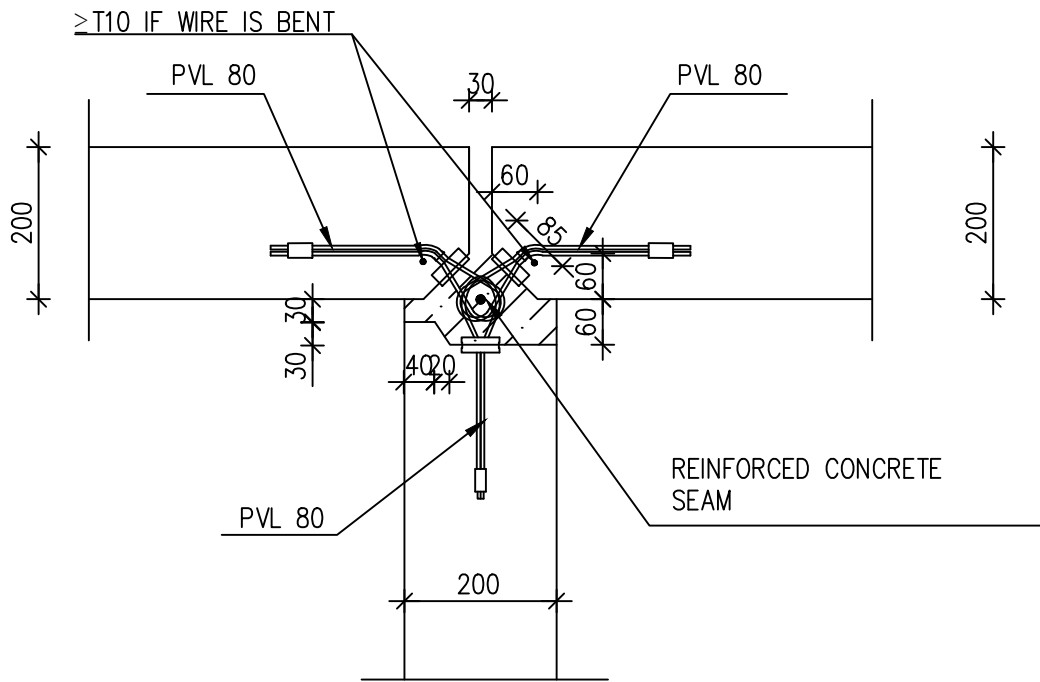

Design Shear resistance  $V_{Rd}$ (kN/m) of PVL 60, PVL80, PVL 100, PVL 120 Wire Loop

Concrete strength (EC 2)	Spacing of loops (mm)										
	250	300	350	400	450	500	550	600	650	700	750
C25/30	153	132	116	105	96	89	83	78	74	70	67
C30/37	156	134	119	107	99	91	86	81	77	73	70
C35/45	158	137	122	110	101	94	88	83	79	76	73

Design Shear resistance  $V_{Rd}$ (kN/m) of PVL 140 Wire Loop

Concrete strength (EC 2)	Spacing of loops (mm)							
	350	400	450	500	550	600	650	700
C25/30	170	153	137	123	112	103	96	90
C30/37	185	165	148	134	121	111	103	97
C35/45	197	177	158	143	130	119	110	103

WALL ELEMENT  
CONNECTION

1:10

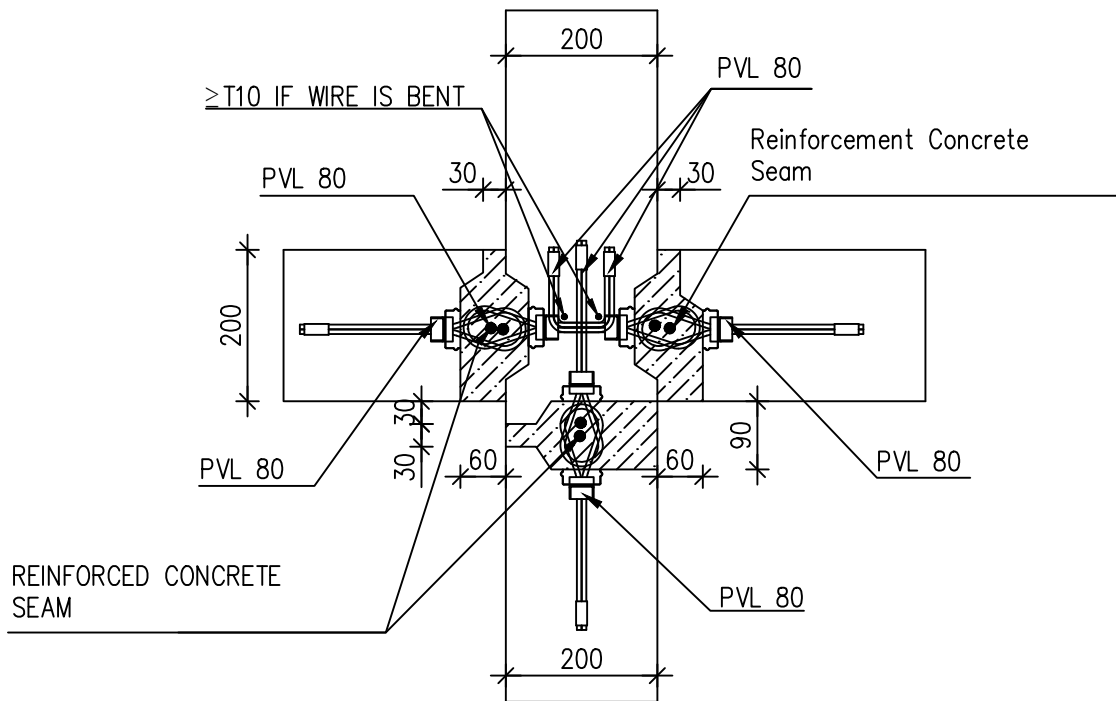

Design Shear resistance  $V_{Rd}$ (kN/m) of PVL 60, PVL 80, PVL 100, PVL 120 Wire Loop

Concrete strength (EC 2)	Spacing of loops (mm)										
	250	300	350	400	450	500	550	600	650	700	750
C25/30	153	132	116	105	96	89	83	78	74	70	67
C30/37	156	134	119	107	99	91	86	81	77	73	70
C35/45	158	137	122	110	101	94	88	83	79	76	73

Design Shear resistance  $V_{Rd}$ (kN/m) of PVL 140 Wire Loop

Concrete strength (EC 2)	Spacing of loops (mm)							
	350	400	450	500	550	600	650	700
C25/30	170	153	137	123	112	103	96	90
C30/37	185	165	148	134	121	111	103	97
C35/45	197	177	158	143	130	119	110	103



## WALL ELEMENT CONNECTION

1:10

According to the elemental images

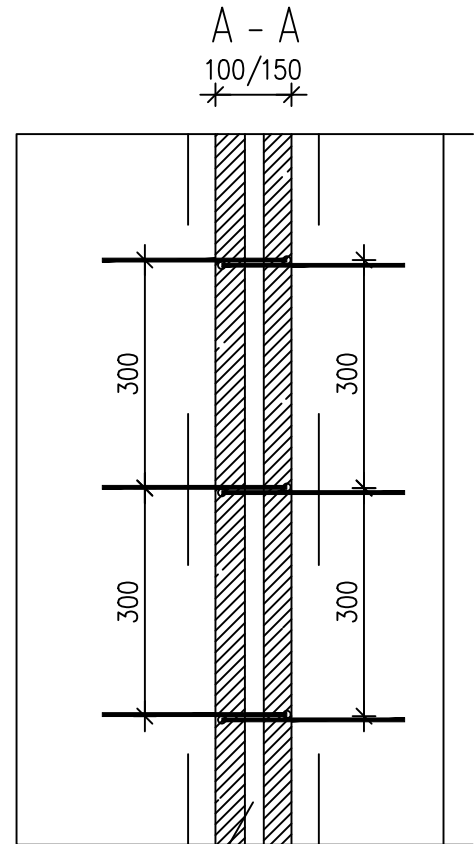
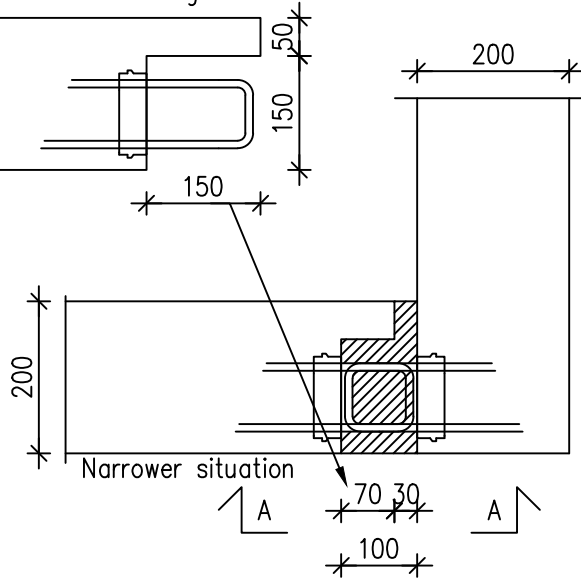
REINFORCED  
CONCRETE SEAMDesign Shear resistance  $V_{Rd}$  (kN/m) of U-bar (TS-joint) connection

$f_{ck,s}$ (MPa)	$f_{yk}$ (MPa)	$\phi$ (mm)	c/c (mm)	$\gamma_c$	$A_s/s$ (mm <sup>2</sup> /m)	$V_{Rd}$ (kN/m)
30	500	8	300	1,2	335	107,1
30	500	8	150	1,5	670	171,3
30	500	10	300	1,5	524	133,8
30	500	10	150	1,5	1047	267,7
30	500	12	300	1,5	754	192,7
30	500	12	150	1,5	1508	385,4
35	500	12	150	1,2	1508	416,3
25	500	8	300	1,5	335	78,2
25	500	10	300	1,5	524	122,2
25	500	12	300	1,5	754	175,9
35	500	16	300	1,5	1340	370,1

REINFORCING WALLS, STEEL LINK JOINTS  
STAIRS / SHAFTS, TOP FLOORS

1:10

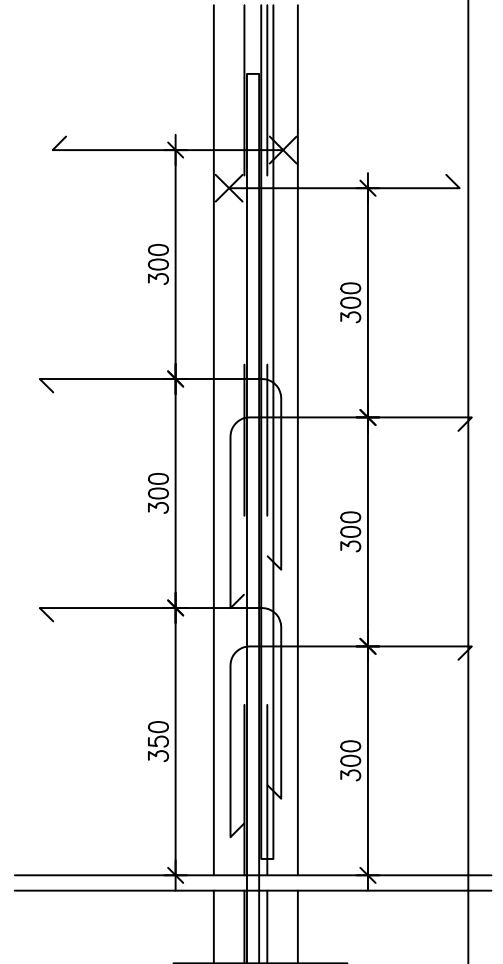
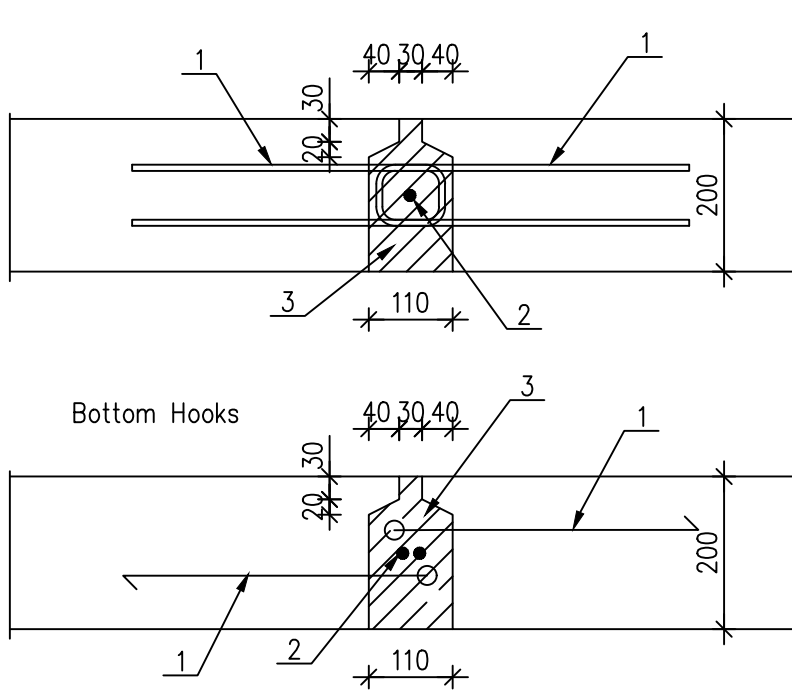

- 1 Loops for T10-k300 with 2 or 3 k300 hooks at the bottom
- 2 Seam steel T25, L = Height of layer + 1200mm
- 3 Vertical Joint

