

Galina Kukushkina

INDIRECT ADIABATIC COOLING

Bachelor's thesis
Double Degree programme
Building Services Engineering

April 2011



MIKKELIN AMMATTIKORKEAKOULU

Mikkeli University of Applied Sciences

DESCRIPTION

 <p>MIKKELIN AMMATTIKORKEAKOULU Mikkeli University of Applied Sciences</p>		Date of the bachelor's thesis 28.04.2011
Author(s) Galina Kukushkina	Degree programme and option Double Degree programme Building Services Engineering	
Name of the bachelor's thesis Indirect Adiabatic Cooling		
Abstract <p>The subject of this thesis is the indirect adiabatic cooling. The application of such technology makes it possible to reduce the use of expensive and energy-intensive refrigerators. In addition indirect adiabatic cooling is energy efficient and profit-proved. Also it decreases the emission of fluorine-chloride refrigerants, which are charged by cooling units.</p> <p>Chapter 2 gives the definition of the indirect adiabatic cooling and tells about its development. Also it describes the air-conditioner Type 55/56 Adsolair by Menerga with adiabatic cooling.</p> <p>Chapter 3 familiarizes with factors influencing on the efficiency of the indirect adiabatic cooling: humidification and heat transfer. It briefly describes some different types of humidifiers and heat exchangers.</p> <p>Chapter 4 describes initial data for simulation and calculation methods that is used by Fläkt Woods' selection tool Acon.</p> <p>Chapter 5 presents results and the analysis of indirect adiabatic cooling simulation that was made with computer-aided selection program Acon.</p> <p>Chapter 6 discusses the results of indirect adiabatic cooling simulation in different climate. The advantages and disadvantages of this system are described in comparison to compressor cooling. Also the recommendations and ways to improvements are pointed.</p>		
Subject headings, (keywords) Indirect adiabatic cooling, heat exchanger, humidification, evaporation, temperature efficiency, energy demand, CO ₂ emissions, life cycle cost		
Pages 35, appendixes 1	Language English	URN
Remarks, notes on appendices		
Tutor Heikki Salomaa	Employer of the bachelor's thesis	

CONTENTS

1	INTRODUCTION.....	1
2	BACKGROUND OF THE INDIRECT ADIABATIC COOLING.....	2
2.1	Definition of the Adiabatic Cooling.....	2
2.2	History of the Indirect Adiabatic Cooling.....	5
2.3	Air-handling Unit with Adiabatic Cooling.....	7
2.3.1	Operation Cycles	7
2.3.2	Indirect Adiabatic Cooling	9
2.3.3	Two Stage Recuperative Heat Exchanger	10
3	FACTORS INFLUENCING ON THE EFFICIENCY	11
3.1	Humidification	11
3.2	Heat Transfer.....	12
4	DESIGN DATA AND METHODS.....	13
4.1	Climate Data.....	13
4.2	Calculation method	14
4.3	Indoor Air Data	15
4.4	AHU model	17
4.5	Operation and Energy Cost	17
5	INDIRECT ADIABATIC COOLING SIMULATION.....	18
5.1	Duration Diagram.....	18
5.2	Life Cycle Assessment	19
5.3	Results and Analysis	19
5.3.1	Climate 1 – Humid cold, cool summer.....	19
5.3.2	Climate 2 – Humid equatorial, dry winter.....	23
5.3.3	Climate 3 – Dry arid, hot.....	27
6	DISCUSSION AND CONCLUSIONS	32

1 INTRODUCTION

In fact, a lot of energy resources are consumed to operate ventilation and air-conditioning in buildings. Energy production has a negative impact on our environment and contributes to the CO₂ emissions to our atmosphere. Reduction of the energy consumption and CO₂ emissions can be achieved with help of energy efficient systems.

Indirect adiabatic cooling (=IAC) is a method of cooling the outside air without increasing its humidity ratio. In summer this technology provides gentle air-conditioning and consumes the minimum energy. Indirect adiabatic cooling is based on cooling which is delivered by supply air. The supply air is distributed in two ways: mixing or displacement ventilation. Displacement ventilation is essentially buoyancy driven process. The supply air is introduced at low velocity and at low-level into the occupied zone at a temperature slightly cooler than the design room air temperature.

Indirect adiabatic cooling provides up to 10 °C cooling effect without the use of refrigerants or additional power. It is an ideal partner technology for displacement ventilation.

The aim of this thesis is to prove energy efficiency of indirect adiabatic cooling and to define the application area in northern Europe climate.

In order to reach the assigned aim the following tasks are solved:

- to study background of indirect adiabatic cooling;
- to familiarize with products and manufacturers of indirect adiabatic cooling;
- to calculate energy demand, cost and CO₂ emissions.

2 BACKGROUND OF THE INDIRECT ADIABATIC COOLING

This chapter gives the definition of the indirect adiabatic cooling and tells about its development. Also it describes the air-conditioner Type 55/56 Adsolair by Menerga with adiabatic cooling.

2.1 Definition of the Adiabatic Cooling

Adiabatic cooling is the humidifying of air under adiabatic conditions, so that heat energy is neither added nor removed. The process occurs when the air is in contact with water. The heat required for evaporation is taken from the air, consequently air temperature decreases, but moisture content increases. The minimum possible temperature is the cooling limit on the saturation line (wet bulb temperature). In the Mollier h-x diagram adiabatic cooling process is expressed as straight line down-directed in the line of $h = \text{const}$ (Figure 1). /1, p. 2./

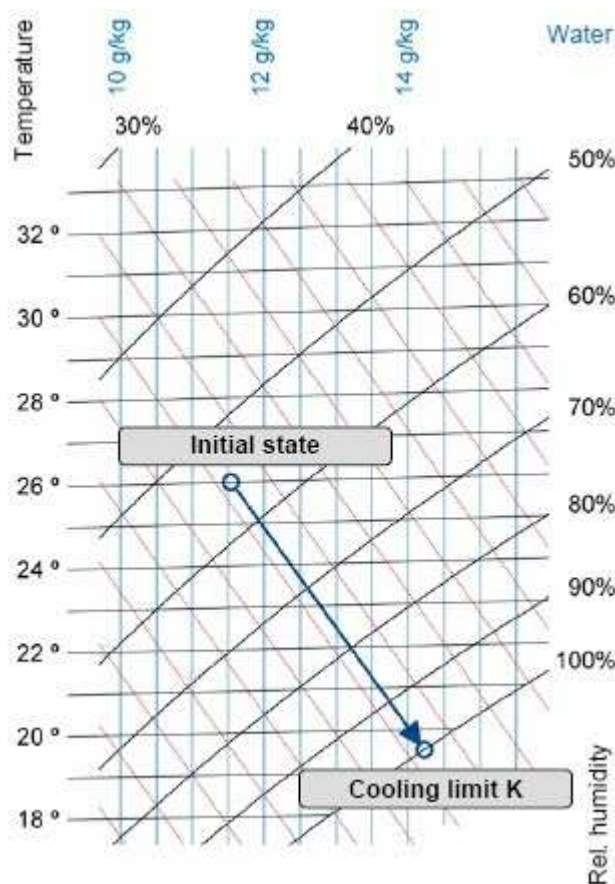

Figure 1. The direct adiabatic air humidification /1, p. 2./

The difference between the air wet bulb temperature and the air dry bulb temperature is a measure of the potential for evaporative cooling. The greater the difference between these two temperatures, the greater the evaporative cooling effect. When the temperatures are the same, there is no evaporation of water in air and thus no cooling effect. /2, p. 3./

Adiabatic cooling can be either direct or indirect. In the *direct adiabatic cooling* the outdoor air which is to be cooled is humidified (Figure 1), so this causes an increase in ambient humidity. A possible contamination of the supply air due to the humidification also has to be considered. Therefore this system is used only in few applications, e.g. in industrial building. /1, p. 2./ In the *indirect adiabatic cooling* the exhaust air is humidified and cooled and then, via a heat exchanger, it cools down the outdoor air i.e. indirectly. So the supply air is not humidified and a possible contamination is ruled out. /1, p. 3./

The efficiency of an adiabatic cooling system η_A is “the ratio between the actual cooling of the supply air and the theoretical maximum achievable cooling in the process, the cooling limit temperature”:

$$\eta_A = \frac{t_{12} - t_{13}}{t_{12} - t_{20K}} \cdot 100\% , \quad (1)$$

where

η_A – an adiabatic efficiency, %;

t_{12} – an air temperature before a heat exchanger, °C;

t_{13} – an air temperature after a heat exchanger, °C;

t_{20K} – a cooling limit temperature, °C. /1, p. 4./

A *two-stage indirect adiabatic cooling* is the process where humidification and transfer of cold are separate both in space and in time (Figure 2). At first the exhaust air is humidified (see Figure 2, the process 21-22) and then the coolness is transferred from the exhaust air to the outdoor air in a heat exchanger (see Figure 2, the process 12-13). In this process an adiabatic efficiency reaches around 80% at the average. /1, p. 3./

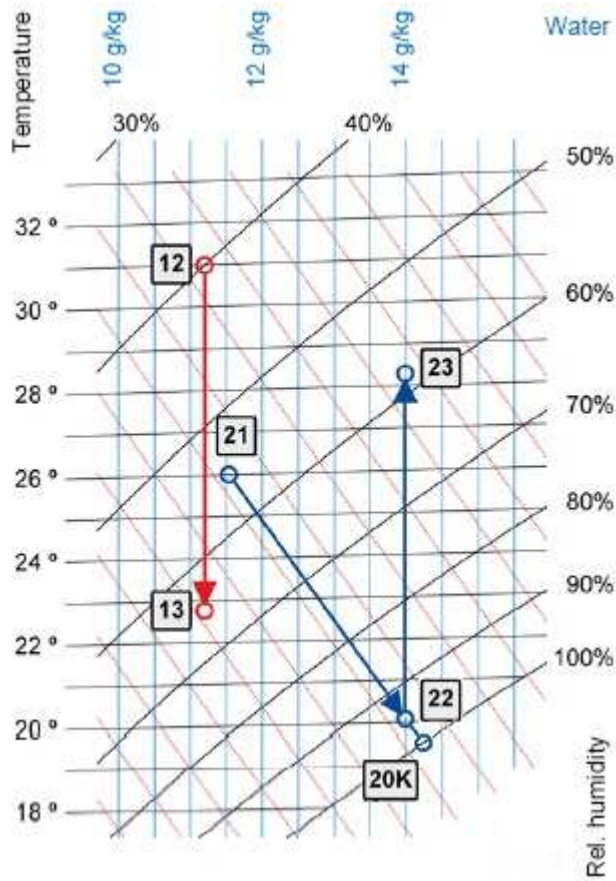

Figure 2. The two-stage indirect adiabatic cooling /1, p. 3./

A *single-stage indirect adiabatic cooling* is the process where humidification and transfer of cold occur in the same space and at the same time. The exhaust air is humidified directly in the heat exchanger (Figure 3). The energy necessary for the evaporation is taken from the exhaust air and via heat transfer from the outdoor air. This is no longer adiabatic process. However, both operation and efficiency are similar to those of the two-stage indirect adiabatic cooling. In this process an adiabatic efficiency achieves about 76% at the average. /1, p. 4./

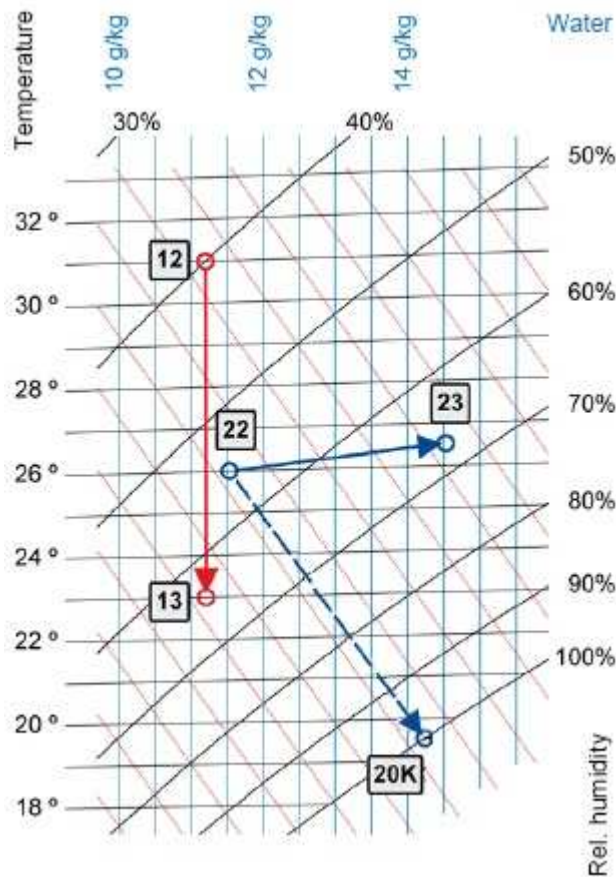

Figure 3. The single-stage indirect adiabatic cooling /1, p. 4./

Evaporative cooling is not the same principle as that used by vapor-compression refrigeration units, although that process also requires evaporation. It is important to distinguish between these principles. In a vapor-compression cycle, the refrigerant evaporates inside the evaporator coils, the refrigerant gas is compressed and cooled, causing it to return to its liquid state. This cooling process needs energy to keep running. In contrast an evaporative cooler's water is only evaporated once and on one's own.

2.2 History of the Indirect Adiabatic Cooling

The simplest mode of air cooling is known to mankind from times immemorial. The earliest archaeological data about the evaporative cooling mechanisms points to the Ancient Egypt. These mechanisms consist of porous water pots, water ponds and thin water chutes integrated into thick-walled and shaded enclosure. Frescoes dated to 2500 B.C. shows slaves fanning water pots to cool rooms for the royalty. Some of the water leaked out through the pot wall due to porous structure and evaporated. Jugs were placed at the window for air cooling. A passive downdraught evaporative cool-

ing started to spread to other countries with dry and hot climate after it had been found in Ancient Egypt.

In the early 1900s, air washers and air coolers were invented in the United States (Arizona and California). The air washers passed air through water spray, which cleaned and cooled the air. The air coolers included indirect coolers, where air passed over a water-cooled coil, and direct coolers where air was cooled by direct contact with water.

The first evaporative cooler patent was registered in 1906 in United States. The main element of this cooler is excelsior (wood wool) pads. It brings a large amount of water in contact with moving air to allow the evaporation to occur. /3/

With the lapse of time the evaporative cooler progressed. In 1945 the new type of evaporative cooler was registered in United States by Bryant Essick. It includes a water reservoir with level controlled by a float valve, a pump to circulate water over the excelsior pads, and a squirrel-cage fan to draw air through the pads and into the premises. /4/

In 1963 John Watt developed the first serious analysis of direct and indirect evaporative cooling systems. The 1986 Dr. Watt's edition of *Evaporative Air Conditioning Handbook* identifies the origins for modern American evaporative cooling.

For the first time the method for indirect evaporative air cooling was patented by Valery S. Maisotsenko and Alexandr N. Gershuni in 1990 in Ukraine. "The present invention relates to methods for air cooling with the use of heat-exchangers of the indirect evaporative type and can find most utility when applied for air cooling in those premises or accommodations which must be isolate from the surrounding atmosphere either for technological reasons or on account of labor protection condition, etc". /5, p. 3./

Nowadays the district heating, ventilation and air-conditioning systems, the industrial plants with steam humidification systems are transformed into adiabatic systems to achieve the considerable decrease in power inputs and service costs. The leading manufacturers of air-conditioning systems have gained experience in designing, commissioning and operation of air-handling units (=AHU) using the indirect adiabatic

cooling and engineers design and install the indirect adiabatic cooling systems with certainty. /6/ Also these systems have spread to country with temperate climate thanks to additional equipment. For example type 55/56 Adsolair solVent air conditioning unit was developed in 1999 by Menerga GmbH. In summer it provides gentle air conditioning of the building by evaporation of water.

2.3 Air-handling Unit with Adiabatic Cooling

The air-conditioner Type 55/56 Adsolair by Menerga with adiabatic cooling consumes the minimum energy thanks to the cross counterflow configuration of the double plate heat exchanger. Its temperature efficiency reaches above 75 %. In summer the indirect adiabatic cooling provides gentle air-conditioning of the building.



Figure 4. Type 55/56 Adsolair by Menerga

The following information is based on the technical documentation of Adsolair sol-Vent by Menerga /7, p. 1; 8, p.2/.

2.3.1 Operation Cycles

During heating period the exhaust air passes sensible heat to the outdoor air through the plate heat exchanger. And under low outside temperature the exhaust air passes also latent heat when the water vapour of exhaust air is condensated. At the same time the outdoor air can be heated up more by heating coil to required temperature and enters into premises. In the issue this heat exchange the exhaust air is cooled down and remove out. As appropriate the supply air parcel can be increased by admixing the inside air if there is the recirculation damper. (Figure 5)

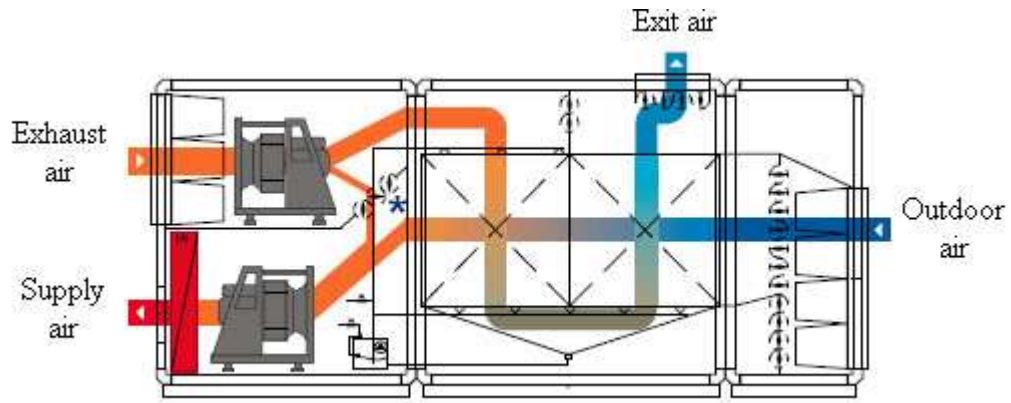

Figure 5. Operation cycle 1 of type 55/56 Adsolair

In recirculated mode the air handling unit operates as heating. The air is heated by hot water heating coil (Figure 6).

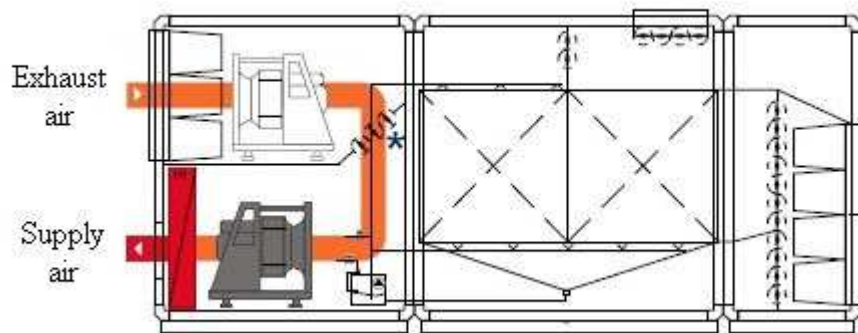

Figure 6. Operation cycle 2 of type 55/56 Adsolair

In transition by significant heat losses Adsolair provides the required indoor climate by heat recovery control. That control occurs by partial passing both exhaust, and outdoor air through upper and lower bypass damper of recuperative heat exchanger. (Figure 7)

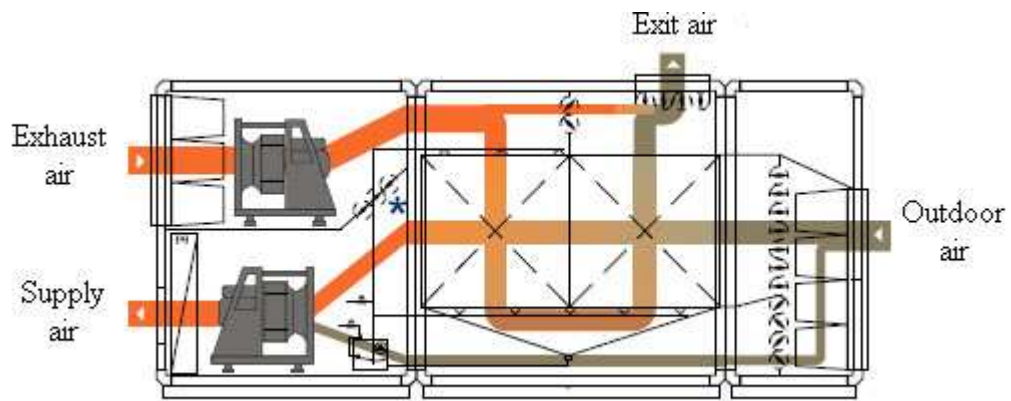

Figure 7. Operation cycle 3 of type 55/56 Adsolair

In summer or if the outdoor temperature is too high, the required indoor climate is ensured by supply-and-exhaust ventilation through the bypass without heat recovery (Figure 8).

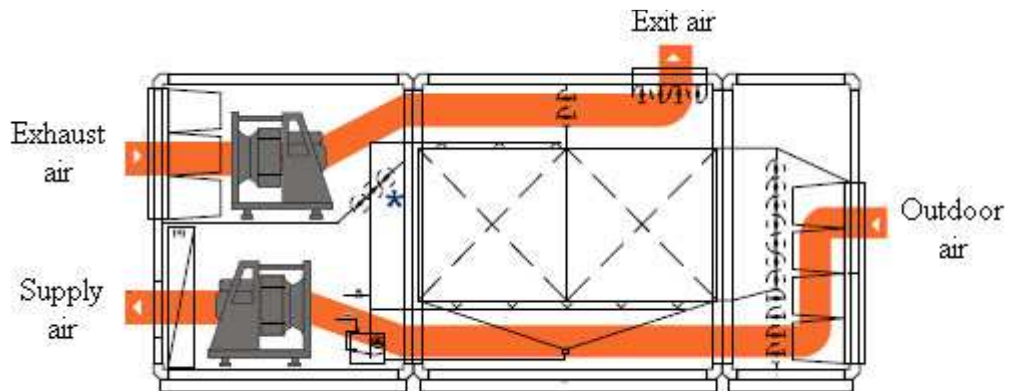

Figure 8. Operation cycle 4 of type 55/56 Adsolair

At summertime the outside hot air is cooled down in recuperative heat exchanger. Water is sprayed into the exhaust air stream over the recuperator. Indirect adiabatic cooling of supply air is occurred. (Figure 9)

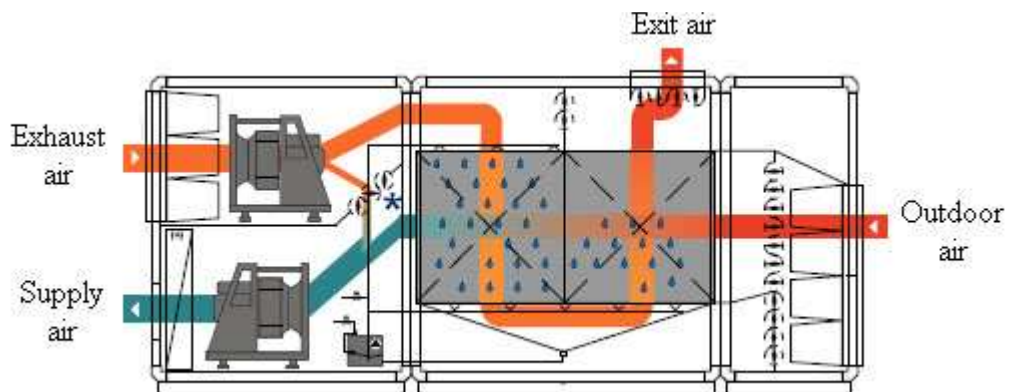

Figure 9. Operation cycle 5 of type 55/56 Adsolair

2.3.2 Indirect Adiabatic Cooling

It is known that adiabatic cooling along with mechanical cooling is well applied in the air handling unit. But the using of the direct adiabatic cooling of the supply air is not recommended according to hygienic reasons, because in such way the air humidity increases in premises. And the problem of humidifier maintenance appears. It is a risk of supply air contamination also. The principle of the indirect adiabatic cooling is used in an air handling unit Adsolair, which on the one hand is easy and cheap, but on the

other hand doesn't increase the air humidity. The main part of this system is the double plate recuperative heat exchanger. The exhaust side of this recuperator is sprayed by water. The water evaporates and as a result the exhaust air becomes moist and cool. In consideration of this the temperature difference between outside and exhaust air arises. The heat exchange happens through the plastic sides of heat exchanger, and the outside air is cooled down without humidification. The sprayed water is taken from the water sump by pump and sprinkled in passing and against the exhaust air movement. The spraying is so intensive, that the outside air is cooled down even 10 °C. The process regulation is provided with periodically switching on and off of the sprinkling pump. The spray water is cleaned in the filter to avoid the nozzles clogging. The water in the water sump is continuously fed from the water supply system.

The IAC system includes the line of water nozzles with pipes and pump taking the water from the water sump. The pump is equipped with an automatic on-off switch system, water sump emptying signal and automatic water sump recharging. /7, p. 4./

2.3.3 Two Stage Recuperative Heat Exchanger

The AHU «heart» is two stage recuperative heat exchanger. It is made of thin propylene plates. It provides a small air resistance and maximum heat-transfer coefficient. The propylene is noncorrodible, wearproof and stable towards acids and alkalis. The fire rating is B1 according to the standard DIN 4102. Bypass canals with bypass valves and the water sump are also made of propylene. The bypass canals give an opportunity to increase AHU performance in summer period. /7, p. 4./

3 FACTORS INFLUENCING ON THE EFFICIENCY

This chapter familiarizes with factors influencing on the efficiency of the indirect adiabatic cooling: humidification and heat transfer. It briefly describes some different types of humidifiers and heat exchangers.

“The efficiency of indirect adiabatic cooling process depends on the one hand on the quality of the humidification and on the other hand on the quality of the heat transfer”. But the operation experience of indirect adiabatic system shows that the maximum efficiency does not always mean the minimum energy and operation costs. /2, p. 5./

3.1 Humidification

“Basically it can be said that the quality of humidification (humidification efficiency) is directly coupled to the required water quality”. In some cases it is not obvious which product or which technology is done for the corresponded application and conditions. The humidification systems are classed as follows: evaporative humidifier, spray humidifier and high pressure humidifier. /2, p. 5./

The evaporative humidifier has used for many years successfully, mainly in USA. It is reliable and cost-efficient, easy-to-work and is suitable for use in all types of ventilation systems. The water evaporates from wet, unheated humidifier fills. The moisture is transferred to the air by evaporation from the water film running down the surfaces of the humidifier fills. Any water can be used while the material of humidifier fills is stable. When the usual water is applied the lime scale is arisen and the humidifying efficiency will decrease. /2, p. 5; 9./

The spray humidifier is commonly used in Europe with the single-stage adiabatic cooling process at the present. It represents a low-pressure nozzle without the compressed air in combination with a large ceramic sprayer. This porous material absorbs sprayed water and sprays it again. A small amount of waste water is formed due to this principle. The spray humidifier is reliable and sturdy (especially for large nozzle diameters). It is allowed to use desalinated water for this system. /2, p. 5; 9./

The high pressure humidifier does not use compressed air. Instead, the energy for spraying is taken from water under high pressure. Water is supplied to nozzle by high

pressure pump at a pressure of 80 to 100 bar. There are nozzles with ceramic insert that increases their service life. Its high humidifying efficiency usually requires treated water. It is possible to use the desalinated water. But the plain water destroyed jets due to formation of mineral salts. Also mineral salts destroyed evaporator. /9/

3.2 Heat Transfer

The two-stage adiabatic cooling process admits the use of all kinds of heat exchangers. But it is important that no moisture is transferred, otherwise the cooling potential reduces. In practice plate heat exchangers and rotating wheels are used in the two-stage adiabatic cooling process. In order to increase the temperature efficiency, two plate heat exchangers are connected in series or (in the case of smaller air flow volumes) counter-current heat exchangers are used. /2, p. 5./

The temperature efficiency dependence on supply air temperature is presented on Figure 10. The exhaust air temperature is $t_{ex} = 20.2 \text{ }^{\circ}\text{C}$.

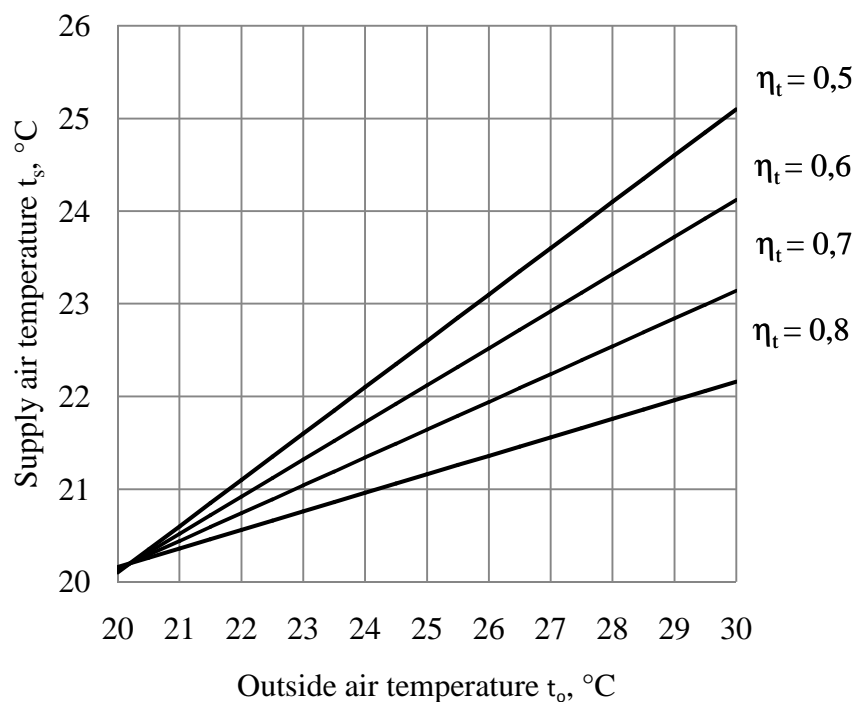

Figure 10. Supply air temperature after heat exchanger

4 DESIGN DATA AND METHODS

This chapter describes initial data for simulation and calculation methods that is used by Fläkt Woods' selection tool Acon.

Fläkt Woods' selection tool Acon can calculate the annual energy cost and the life cycle energy costs for the selected air-handling unit. Acon considers all energy consumers (e.g. fans, pumps, heaters, coolers and heat exchangers). The following information is based on Fläkt Woods' LCC brochure /10/.

4.1 Climate Data

Acon uses meteorological data from the Swiss database METEONORM[®]; which consists of climate data for a large number of locations worldwide. As the efficiency of heat exchangers, heaters and coolers differs with the temperature conditions, the calculations are done at several data points during the year. The resulting heating and cooling demand are summed up for the specified annual running hours. /10, p. 1./

The outdoor temperature and humidity are tabled hour by hour for the whole year at a specific location. A calculation of heating and cooling demand for the annual 8760 hours would be very time consuming, and therefore Fläkt Woods has created a degree- and enthalpy-hour curve that is based on five points for each specific case:

- 1) the highest annual temperature and humidity in this temperature;
- 2) the lowest temperature of the 100 hottest hours of the year.;
- 3) the annual mean value for temperature and humidity in this temperature;
- 4) the highest temperature of the 100 coldest hours of the year;
- 5) the lowest annual temperature and humidity in this temperature.

To draw the temperature curve according to these five points, it was compared to a well-known curve, which also corresponds to DIN 4710. After that, the curve equation after the measured curve has been generated. /10, p. 2./

The temperature/enthalpy diagram describes the mean value of temperature and enthalpy for an air handling unit that is operational 24 hours per day. If the running time is limited to daytime operation, the curve will have an offset by 0.12° Celsius upwards for every hour less than 24 hours. /10, p. 2./

There are three different climate data which are used for IAC simulation of this thesis: humid and cold (Jyväskylä, Finland), humid and hot (Bangkok, Thailand), dry and hot (Cairo, Egypt). Climate data is presented in Table 1.

Table 1. Climate data for IAC simulation /11/

Climate	Humid cold, cool summer		Humid equatorial, dry winter		Dry arid, hot	
	Jyväskylä (Finland)		Bangkok (Thailand)		Cairo (Egypt)	
	Temperature, °C	Moisture, %	Temperature, °C	Moisture, %	Temperature, °C	Moisture, %
Average year temperature/moisture in this temperature	2,7	96,9	27,7	74,5	21,1	54,9
Year highest temperature/moisture in this temperature	27,4	46,3	36,4	55,3	38,7	34,5
Normal temperature, summer	23		34,1		34,1	
Normal temperature, winter	-25,3		20,3		8,3	
Year lowest temperature /moisture in this temperature	-32	99,9	17	84,9	2,2	81,3

4.2 Calculation method

To achieve a high accuracy on the energy calculation, the following important factors are considered:

- The heat transfer of every heater, cooler and heat exchanger differs a lot depending on the conditions of the entering fluid. This means that the conditions of the air are calculated so when it enters a new function.
- When there is a heat recovery wheel in the air handling unit, the leakage flow and the balancing pressure must be considered. The extra pressure and airflow influences the exhaust fan considerably.
- The pressure drop over filters is calculated as the mean value of the start pressure and the final pressure drop.
- All power consumers are included, even pumps and various control motors.

“When calculating the heating and cooling demand, the enthalpy differences between the outdoor air and supply air are added for every 100 hours. The difference between hour per hour calculation and this method is less than 2-3 % of the estimated total energy consumption”. /10, p. 4./

“The supply and exhaust air temperatures must be given for the designed winter and summer cases. Both the supply air temperature and the exhaust air temperature are supposed to be linear in the degree-hour diagram between the input value for winter and the input value for summer. Calculated heating and cooling capacities account for the heat gain in the fan. When cooling the air to the right temperature and humidity, both the targeted temperature and humidity must be given.

There are two options regarding cooling calculations:

- Calculate to reach the right temperature.
- Calculate to reach both the right temperature and the right humidity

When there is need for controlling both temperature and humidity to an exact operating point, we need an air treatment function consisting of a heater, a cooler and a re-heater. This procedure has a large impact on the energy consumption”. /10, p. 5./

4.3 Indoor Air Data

According to the Russian Building Guidelines the optimal temperature for the summer season in the occupied zone is 23 - 25°C and the relative humidity of indoor air is 60 – 30 %, respectively. The optimal temperature for the heating season in the occupied zone is 20 - 22°C and the relative humidity of indoor air is 45 – 30 %, respectively. The air temperature in the occupied zone should not be greater than 28°C for premises with the constant presence of people. /12, Appendix 1,7./ It is allowed to take the relative humidity at 10 % higher in humid climate (near the seas, lakes, etc.) /13, Appendix B./

According to the Part D2 of the National Building Code of Finland “the design temperature for the heating season that is normally used for room temperature in the occupied zone is 21°C. The design temperature for the summer season that is normally used for room temperature in the occupied zone is 23°C. During periods of occupan-

cy, the temperature in the occupied zone should not normally be greater than 25°C. /14, p.8./

Buildings shall be designed and constructed in such a way that the humidity of indoor air will remain within the values specified for the intended use of the buildings. If the humidity of indoor air exceeds the values of 7 g H₂O/kg of dry air, the room air should be humidified for strictly demanding reasons only, e.g. where this is necessary for a production process or is required for the storage conditions. The value of 7 g H₂O/kg of dry air corresponds to a room air condition where the relative humidity is 45% at the room temperature of 21°C and at the air pressure of 101.3 kPa”. /14, p. 10./

In EN ISO 7730, a humidity range of 30 – 70 % RH is recommended, but mainly for indoor air quality reasons. In ASHRAE 55-92 no lower limit, and an upper limit a 17°C dew-point temperature (humidity ratio 12 g/kg).

It should be noted that even as far back as 1936, ASHRAE took into account thermal adaptation when specifying requirements for the indoor temperature. The following text can be found in ASHRAE Handbook 1936, Chapter 3: “It should be kept in mind that southern people, with their more sluggish heat production and lack of adaptability, will demand a comfort zone several degrees higher than those given here for the more active people of northern climates”. /15, p. 36./

The tropical subjects are thermally acceptable with air temperature of 23.2°C and relative humidity of 77% by research result. This relative humidity level exceeded the recommended thresholds stipulated by the International and Singapore Standards. Tropical subjects may be accustomed to the hot and humid climate. Therefore, the range of acceptable RH level in hot and humid climate may be wider than in the temperate climate. /16, p. 47./

Displacement ventilation is based on low velocity and low induction supply of cool air at low level. The supply air temperature is only slightly (2 ... 6 °C) colder than the ambient room air. /17, p. 5./

According to above-listed guidelines the following desired indoor air parameters are accepted for simulation (Table 2).

Table 2. The desired indoor air data for IAC simulation

Climate	Humid cold, cool summer		Humid equatorial, dry winter		Dry arid, hot	
	Jyväskylä (Finland)		Bangkok (Thailand)		Cairo (Egypt)	
	S	W	S	W	S	W
Supply air temperature, °C	22	18	23	21	23	20
Supply air humidity, % relative	60	30	70	30	60	30
Exhaust air temperature, °C	25	21	26	24	26	23
Exhaust air humidity, % relative	70	30	70	30	70	30

Note: S – summer, W – winter.

4.4 AHU model

The model for indirect adiabatic cooling simulation is an air-handling unit with the rotary heat exchangers and the evaporative humidifier. In order to controlling both temperature and humidity to an exact operating point, we need an air treatment function consisting of a heater, a cooler and a reheater. The AHU model is presented in Appendix 1.

The supply and exhaust air flow are equal to 5 m³/s. Specific fan power of the air-handling unit is 1,49 kW/m³/s.

The rotary heat exchanger has the non-hygroscopic rotor and moisture transfer is not considered. The temperature efficiency of the heat exchanger is 76 %.

4.5 Operation and Energy Cost

In the selection tool it is possible to calculate the energy consumption for different air-flows and temperatures at different times. The running hours have huge impact on the energy consumptions. For IAC simulation of this thesis the air-handling unit operates at 100 % air flow 5 days per week 12 hours per day it would be 3120 hours per year.

In calculation the following energy price are used: for heating is 0.06 EUR/kWh and for cooling and electricity is 0.1 EUR /kWh.

5 INDIRECT ADIABATIC COOLING SIMULATION

This chapter presents results and the analysis of indirect adiabatic cooling simulation that was made with computer-aided selection program Acon.

The following information is based on Fläkt Woods' LCC brochure /10, p.7./

5.1 Duration Diagram

The annual energy demand and recovery are represented as surface in the duration diagram. The supply and exhaust air temperatures are supposed to be linear between the input value for winter and the input value for summer.

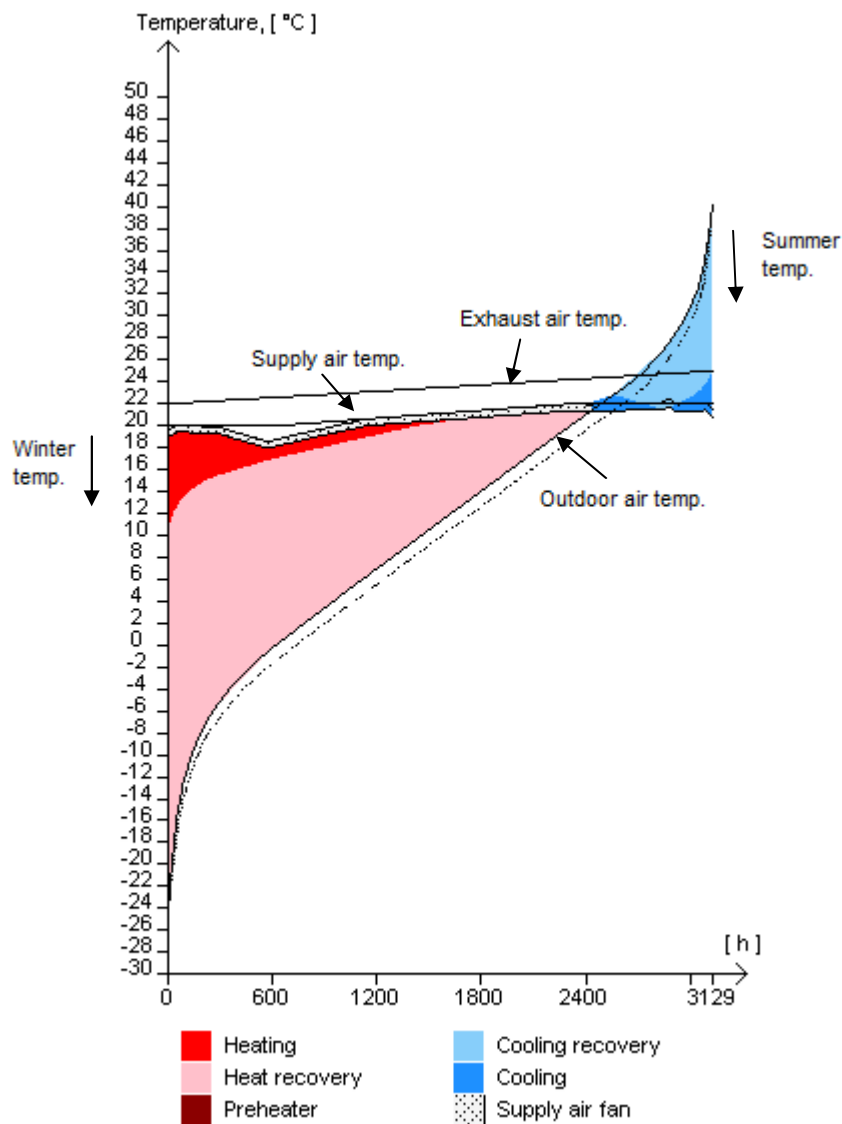

Figure 11. Energy demand and recovery in the duration diagram

For the winter case, the diagram shows the recovered heat energy (pink area), additional heating energy (red area) and heat gain from the supply air fan (dashed area). For the summer case, the diagram shows recovered cooling energy (light blue area), needed cooling energy (blue area), and heat gain from the supply air fan (dashed area). There is the cooling to the right temperature and right humidity; the needed reheat energy is also shown (brown area). Note that the area for cooling only shows the sensible part of the cooling energy (Figure 12).

5.2 Life Cycle Assessment

The Life Cycle Cost is the cost for heating, cooling, and electricity during the air handling units stated lifetime. The LCC-calculation is based on the NPV cost model, and to be able to calculate the total life cycle cost for the air handling unit, energy price and interest rate are needed.

- The energy cost per kWh for different energy fuels must include all fees and costs, which are paid to the energy producer.
- The expected price increase per year should be noted as the actual price increase above the inflation.
- The tender sum is the total cost for the investment including product and installation cost.
- The evaluation sum is the sum of tender sum and the total energy cost.
- Discount rate should be noted as the actual price increase above the inflation.
- The operating time of the air handling unit must also be considered.

To calculate the annual CO₂ emission from an air-handling unit, the amount of CO₂ emission for producing energy to heating, cooling and electricity are set.

5.3 Results and Analysis

5.3.1 Climate 1 – Humid cold, cool summer

At the summer when the normal outdoor air temperature is 23-25 °C, the indirect adiabatic cooling is not used, because the outdoor and exhaust temperature are almost equal. The year highest outdoor air temperature in this climate is considered.

The air state changes for year highest outdoor air temperature $t_{11} = 27.4 \text{ }^{\circ}\text{C}$ in Jyväskylä, Finland are presented in Table 3.

Table 3. Air state changes (Jyväskylä, Finland)

No	Name	Dry bulb temperature, $^{\circ}\text{C}$	Relative humidity, %	Moisture content, g/kg	Enthalpy, kJ/kg
Supply air flow					
1	Outdoor air	27.4	46.3	10.7	54.8
2	REGOTERM rotary heat exchanger	22.9	60.5	10.7	50.2
3	Air cooler for chilled water	21.3	66.5	10.7	48.5
4	Plenum fan Centriflow Plus	22.0	63.8	10.7	49.2
5	Supply air	22.0	63.8	10.7	49.2
Exhaust air flow					
1	Exhaust air	25.0	70.0	14.1	61.0
2	Humidifier, evaporative	21.5	95.3	15.6	61.2
3	REGOTERM rotary heat exchanger	26.0	72.7	15.6	65.8
4	Plenum fan Centriflow Plus	26.8	69.5	15.6	66.6
5	Exit air outlet	26.8	69.5	15.6	66.6

The supply air parameters are permissible. The temperature and enthalpy difference of

outdoor air before and after heat exchanger are:

$$\Delta t = t_{11} - t_{12} = 27.4 - 22.9 = 4.5 \text{ } ^\circ\text{C}$$

$$\Delta h = h_{11} - h_{12} = 54.8 - 50.2 = 4.6 \text{ kJ/kg.}$$

The evaporative humidifier uses water with temperature 10 °C. The humidifier efficiency is 88 %:

$$\eta_{\text{hum}} = \frac{x_2 - x_1}{x_{\text{sat}} - x_1} = \frac{15.6 - 14.1}{15.8 - 14.1} = 0.88.$$

The Life Cycle Cost and CO₂ emissions are calculated and presented in Table 4 for Jyväskylä, Finland.

Table 4. Life cycle cost and CO₂ emissions. Jyväskylä, Finland

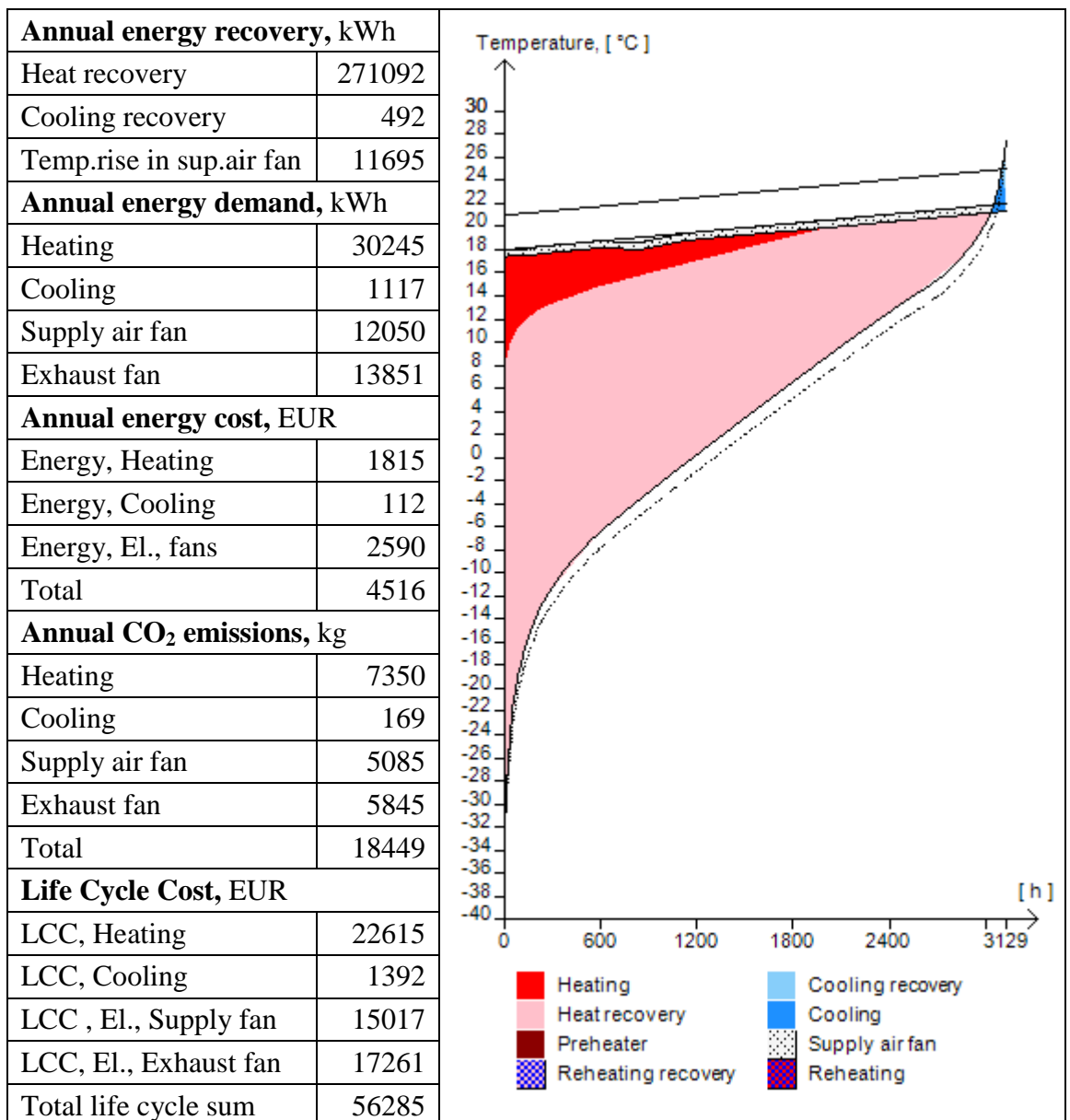

The duration diagram shows the recovered heat energy that is 271092 kWh and the additional heating energy that is 31897 kWh for the winter case. Therefore, about 89.7 % of whole heating demand can be recovered. For the summer case, the diagram shows recovered cooling energy that is 492 kWh, needed extra cooling energy that is 1117 kWh. Therefore, about 30.6 % of whole cooling demand can be recovered. The heat gain from the supply air fan is 11695 kWh. The total CO₂ emissions is 18449 kg. The total life cycle sum is 56285 EUR.

The indirect adiabatic cooling is compared with compressor cooling in the Table 5. The same initial data were used. The model and calculations was made with computer-aided selection program Acon too.

Table 5. IAC and compressor cooling. Jyväskylä, Finland

	IAC	Compressor cooling
Annual energy demand, Cooling, kWh	1117	1847
Annual energy demand, Fans, kWh	25901	9319
Total annual CO ₂ emissions, kg	18449	78400
LCC, Cooling, EUR	1392	2302

The annual cooling energy demand and LCC of IAC is on 39.5 % smaller than demand and cost of compressor cooling. But using heat recovery we need extra energy for fans. Therefore the annual fans energy demand is on 64 % bigger than demand of compressor cooling. Total annual CO₂ emissions demand of IAC is on 76.5 % smaller than emissions of compressor cooling.

The coefficient of performance (=COP) for heat recovery is:

$$\text{COP} = \frac{E_R}{E_E} = \frac{271092 + 492}{25901 - 9319} = 16.37$$

where

E_R – energy that is recovered using heat recovery;

E_E – extra electricity energy that is needed for heat recovery.

The COP is quite high. It means that the air-conditioning system is efficient.

5.3.2 Climate 2 – Humid equatorial, dry winter

The air state changes for summer normal air temperature $t_o = 34.1^\circ\text{C}$ in Bangkok, Thailand are presented in Table 6. In order to controlling both temperature and humidity to an exact operating point, we need an air treatment function consisting of a heater, a cooler and a reheater.

Table 6. Air state changes, $t_o = 34.1^\circ\text{C}$ (Bangkok, Thailand)

No	Name	Dry bulb temperature, $^\circ\text{C}$	Relative humidity, %	Moisture content, g/kg	Enthalpy, kJ/kg
Supply air flow					
1	Outdoor air	34.1	61.3	21.0	88.2
2	REGOTERM rotary heat exchanger	25.0	99.9	20.3	76.8
3	Air cooler for chilled water	17.2	99.9	12.5	48.9
4	Air heater for hot water	22.0	74.6	12.5	54.0
5	Plenum fan Centriflow Plus	22.7	71.4	12.5	54.7
6	Supply air	22.7	71.4	12.5	54.7
Exhaust air flow					
1	Exhaust air	25.9	68.4	14.6	63.1
2	Humidifier, evaporative	22.1	95.0	16.1	63.3
3	REGOTERM rotary heat exchanger	31.3	57.7	16.8	74.5
4	Plenum fan Centriflow Plus	32.1	55.2	16.8	75.3
5	Exit air outlet	32.1	55.2	16.8	75.3

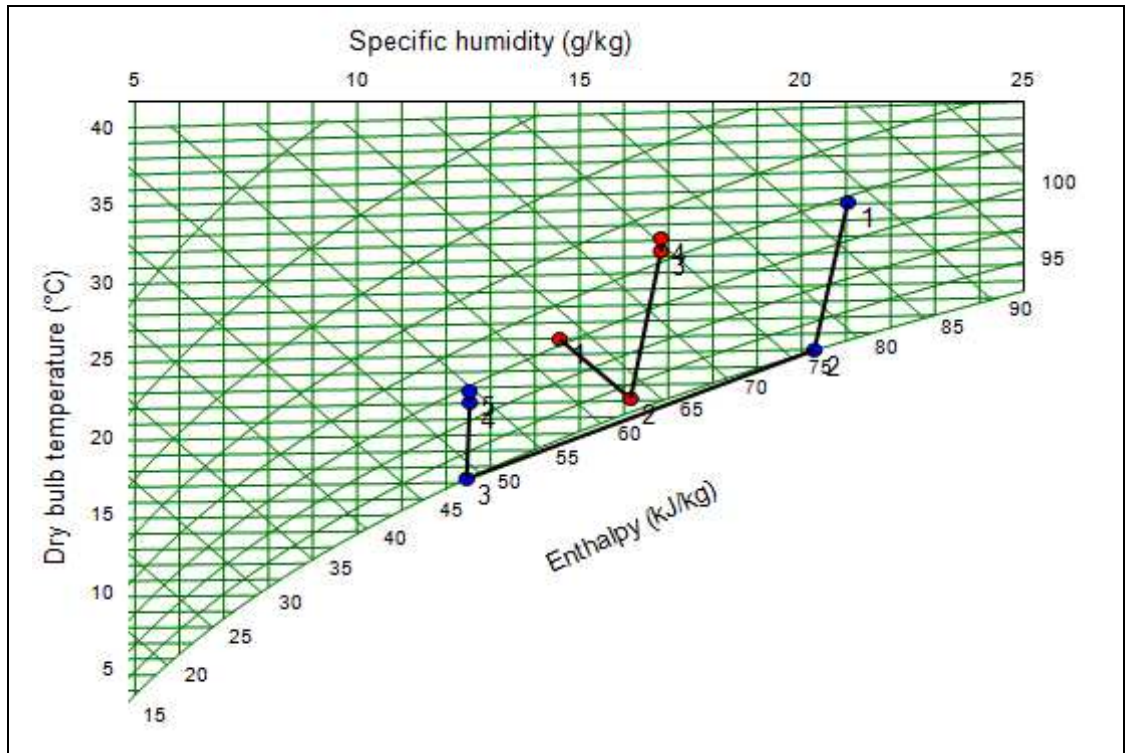

The supply air parameters are permissible. The temperature and enthalpy difference of outdoor air before and after heat exchanger are:

$$\Delta t = t_{11} - t_{12} = 34.1 - 25.0 = 9.1 \text{ }^{\circ}\text{C}$$

$$\Delta h = h_{11} - h_{12} = 88.2 - 76.8 = 11.4 \text{ kJ/kg.}$$

The humidifier efficiency is 79 %:

$$\eta_{\text{hum}} = \frac{x_2 - x_1}{x_{\text{sat}} - x_1} = \frac{16.1 - 14.6}{16.5 - 14.6} = 0.79.$$

The air state changes for year highest outdoor air temperature $t_o = 36.4^{\circ}\text{C}$ in Bangkok, Thailand are presented in Table 7.

Table 7. Air state changes, $t_o = 36.4^{\circ}\text{C}$ (Bangkok, Thailand)

No	Name	Dry bulb temperature, $^{\circ}\text{C}$	Relative humidity, %	Moisture content, g/kg	Enthalpy, kJ/kg
Supply air flow					
1	Outdoor air	36.4	55.3	21.6	92.1
2	REGOTERM rotary heat exchanger	25.8	99.9	21.3	80.1
3	Air cooler for chilled water	17.8	99.9	12.9	50.7
4	Air heater for hot water	22.2	76.7	13.0	55.3

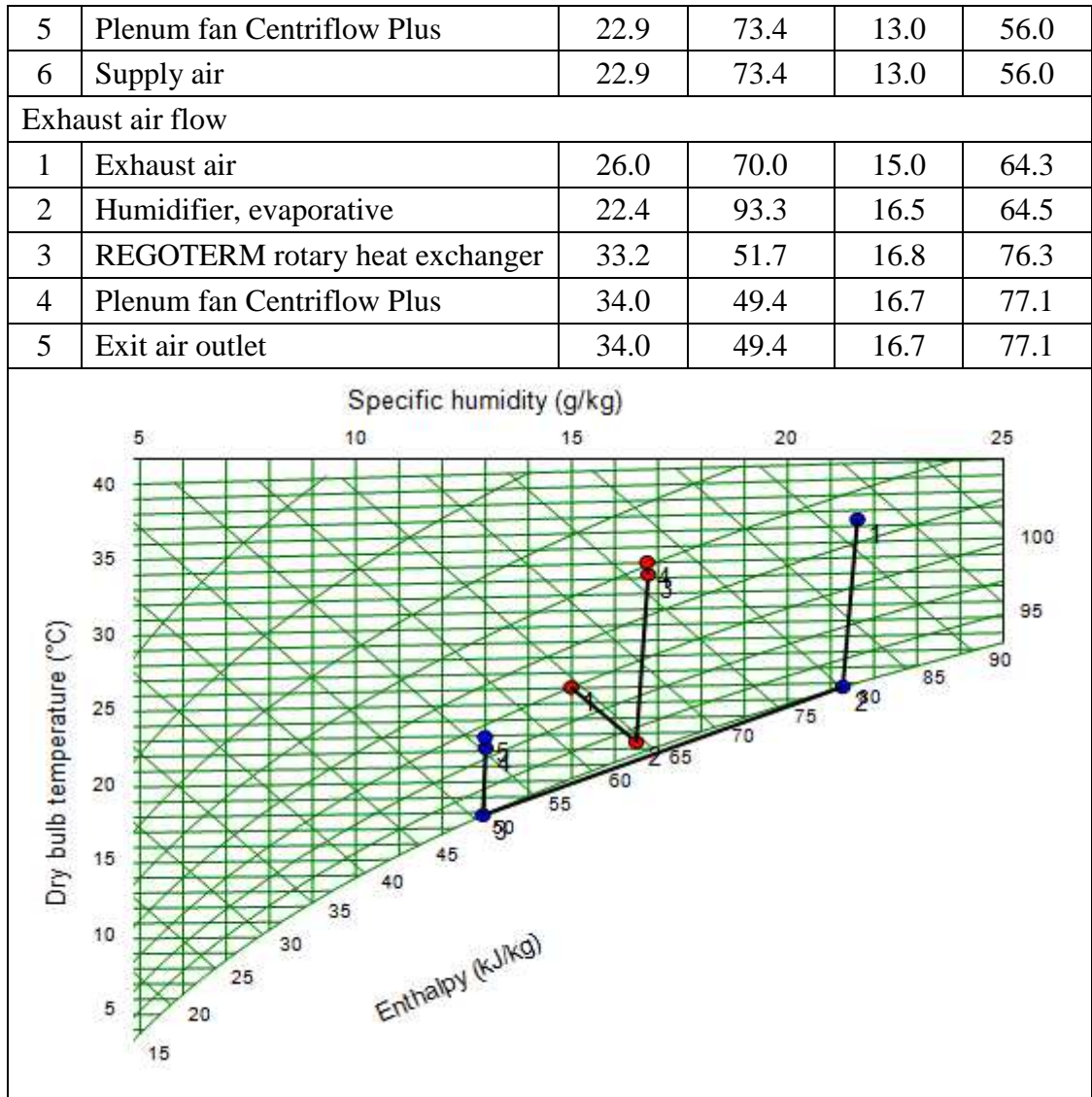

The supply air parameters are permissible. The temperature and enthalpy difference of outdoor air before and after heat exchanger are:

$$\Delta t = t_{11} - t_{12} = 36.4 - 25.8 = 10.6 \text{ }^{\circ}\text{C}$$

$$\Delta h = h_{11} - h_{12} = 92.1 - 80.1 = 12 \text{ kJ/kg.}$$

The humidifier efficiency is 79 %:

$$\eta_{\text{hum}} = \frac{x_{22} - x_{21}}{x_{\text{sat}} - x_{21}} = \frac{16.5 - 15.0}{16.9 - 15.0} = 0.79.$$

The Life Cycle Cost and CO₂ emissions are calculated and presented in Table 8 for Bangkok, Thailand. The duration diagram shows the recovered heat energy that is 359 kWh and the additional heating energy that is 1821 kWh for the winter case. Therefore, about 16.5 % of whole heating demand can be recovered. For the summer case, the diagram shows recovered cooling energy that is 183889 kWh, needed extra cool-

ing energy that is 261927 kWh. Therefore, about 41.2 % of whole cooling demand can be recovered. The reheating energy demand is 73796 kWh. The heat gain from the supply air fan is 70 kWh. The total CO₂ emissions is 33538 kg. The total life cycle sum is 417963 EUR.

Table 8. Life cycle cost and CO₂ emissions. Bangkok, Thailand

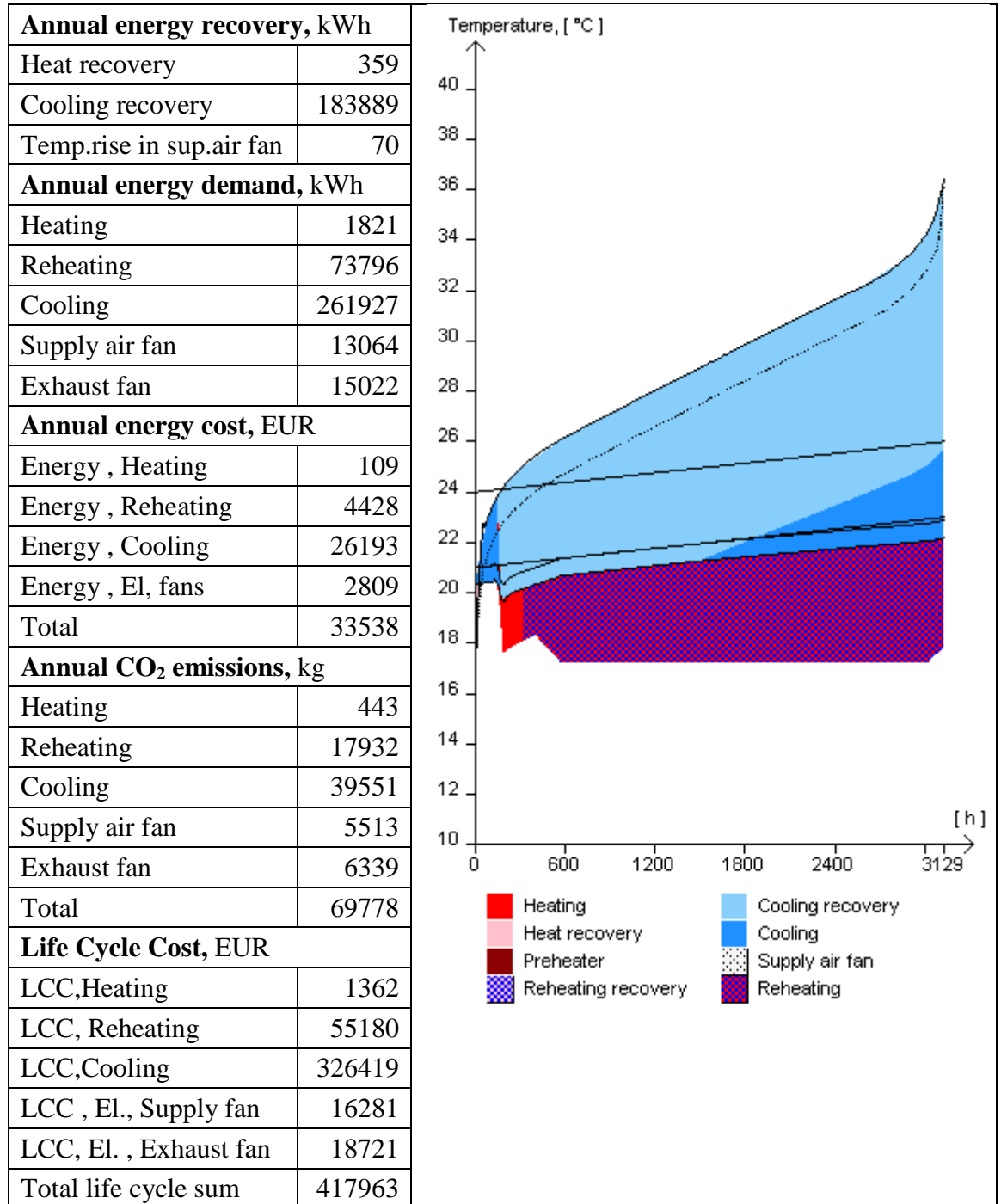

The indirect adiabatic cooling is compared with compressor cooling in the Table 9. The same initial data were used.

Table 9. IAC and compressor cooling. Bangkok, Thailand

	IAC	Compressor cooling
Annual energy demand, Cooling, kWh	261927	283413
Annual energy demand, Fans, kWh	28090	10087
Total annual CO ₂ emissions, kg	69778	47144
LCC, Cooling, EUR	326419	353195

The annual cooling energy demand and LCC of IAC is on 7.6 % smaller than demand and cost of compressor cooling. But using heat recovery we need extra energy for fans. Therefore the annual fans energy demand is on 64.1 % bigger than demand of compressor cooling. Total annual CO₂ emissions demand of IAC is on 32.4 % bigger than emissions of compressor cooling.

The coefficient of performance (=COP) for heat recovery is:

$$\text{COP} = \frac{E_R}{E_E} = \frac{359 + 183889}{28090 - 10087} = 10.23$$

The COP is quite high. It means that the air-conditioning system is efficient.

5.3.3 Climate 3 – Dry arid, hot

The air state changes for summer normal air temperature $t_o = 34.0^\circ\text{C}$ in Cairo, Egypt are presented in Table 10.

Table 10. Air state changes, $t_o = 34.0^\circ\text{C}$ (Cairo, Egypt)

No	Name	Dry bulb temperature, °C	Relative humidity, %	Moisture content, g/kg	Enthalpy, kJ/kg
Supply air flow					
1	Outdoor air	34.0	42.8	14.5	71.4
2	REGOTERM rotary heat exchanger	25.1	71.7	14.5	62.2
3	Air cooler for chilled water	15.2	95.9	10.4	41.7
4	Air heater for hot water	21.7	63.7	10.4	48.3
5	Plenum fan Centriflow Plus	22.4	61.0	10.4	49.1
6	Supply air	22.4	61.0	10.4	49.1
Exhaust air flow					

1	Exhaust air	25.9	69.3	14.8	63.7
2	Humidifier, evaporative	22.3	95.1	16.3	63.8
3	REGOTERM rotary heat exchanger	31.2	56.2	16.3	73.1
4	Plenum fan Centriflow Plus	32.0	53.8	16.3	74.0
5	Exit air outlet	32.0	53.8	16.3	74.0

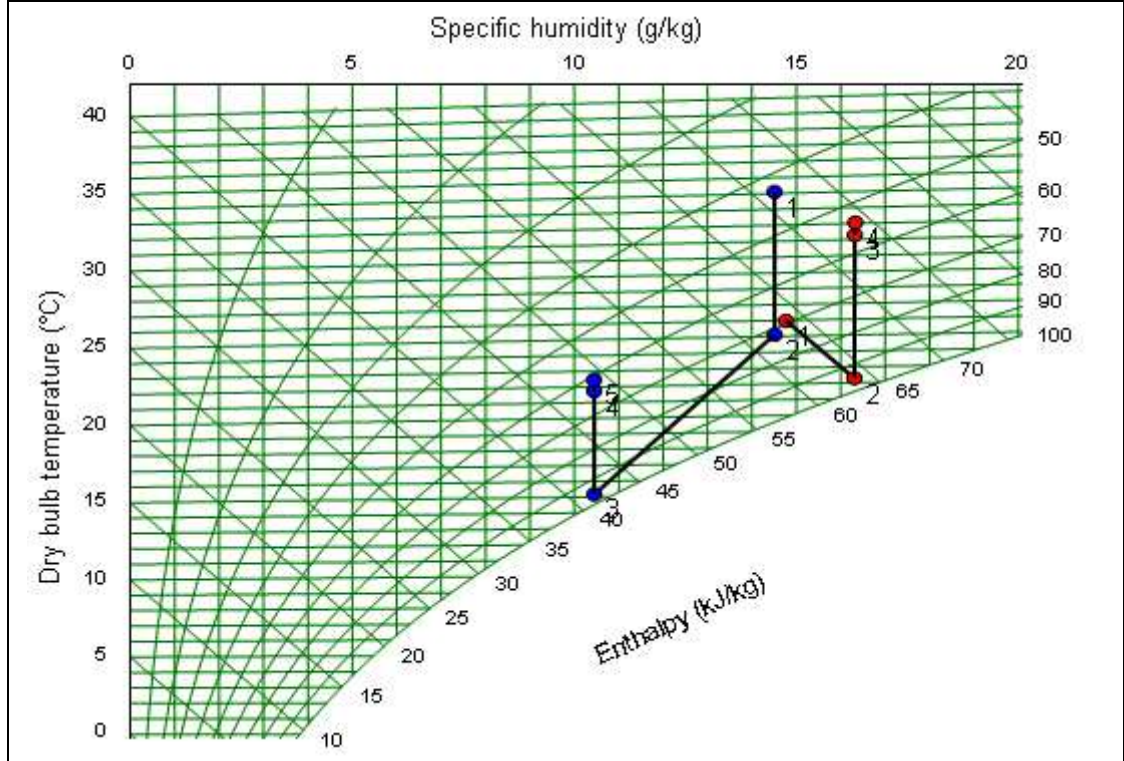

The supply air parameters are permissible. The temperature and enthalpy difference of outdoor air before and after heat exchanger are:

$$\Delta t = t_{11} - t_{12} = 34.0 - 25.1 = 8.9 \text{ }^{\circ}\text{C}$$

$$\Delta h = h_{11} - h_{12} = 71.4 - 62.2 = 9.2 \text{ kJ/kg.}$$

The humidifier efficiency is 83 %:

$$\eta_{\text{hum}} = \frac{x_{22} - x_{21}}{x_{\text{sat}} - x_{21}} = \frac{16.3 - 14.8}{16.6 - 14.8} = 0.83.$$

The air state changes for year highest outdoor air temperature $t_o = 38.7^{\circ}\text{C}$ in Cairo, Egypt are presented in Table 11.

Table 11. Air state changes, $t_o = 38.7^\circ\text{C}$ (Cairo, Egypt)

No	Name	Dry bulb temperature, $^\circ\text{C}$	Relative humidity, %	Moisture content, g/kg	Enthalpy, kJ/kg
Supply air flow					
1	Outdoor air	38.7	34.5	15.1	77.8
2	REGOTERM rotary heat exchanger	26.3	69.4	15.1	65.0
3	Air cooler for chilled water	15.7	95.2	10.8	43.0
4	Air heater for hot water	21.9	65.0	10.8	49.3
5	Plenum fan Centriflow Plus	22.6	62.2	10.8	50.0
6	Supply air	22.6	62.2	10.8	50.0
Exhaust air flow					
1	Exhaust air	26.0	70.0	15.0	64.3
2	Humidifier, evaporative	22.4	95.3	16.5	64.5
3	REGOTERM rotary heat exchanger	34.8	46.4	16.5	77.3
4	Plenum fan Centriflow Plus	35.2	44.4	16.5	78.1
5	Exit air outlet	35.6	44.4	16.5	78.1

The supply air parameters are permissible. The temperature and enthalpy difference of outdoor air before and after heat exchanger are:

$$\Delta t = t_{11} - t_{12} = 38.7 - 26.3 = 12.4 \text{ }^\circ\text{C}$$

$$\Delta h = h_{11} - h_{12} = 77.8 - 65.0 = 12.8 \text{ kJ/kg.}$$

The humidifier efficiency is 83 %:

$$\eta_{\text{hum}} = \frac{x_{22} - x_{21}}{x_{\text{sat}} - x_{21}} = \frac{16.5 - 15.0}{16.8 - 15.0} = 0.83.$$

The Life Cycle Cost and CO₂ emissions are calculated and presented in Table 12 for Cairo, Egypt.

Table 12. Life cycle cost and CO₂ emissions. Cairo, Egypt

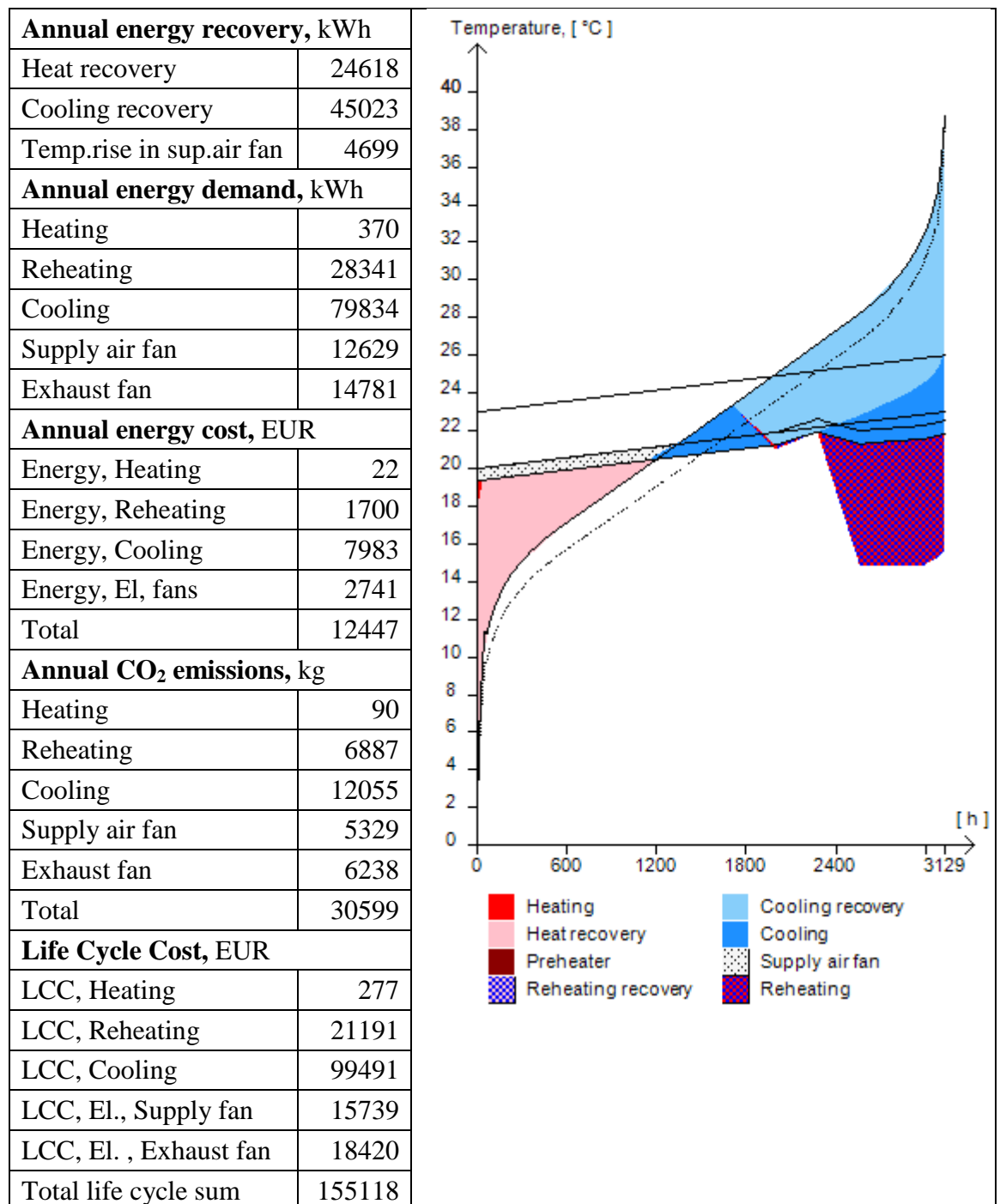

The duration diagram shows the recovered heat energy that is 24618 kWh and the additional heating energy that is 370 kWh for the winter case. Therefore, about 98.5 % of whole heating demand can be recovered. For the summer case, the diagram shows recovered cooling energy that is 45023 kWh, needed extra cooling energy that is 79834 kWh. Therefore, about 36.1 % of whole cooling demand can be recovered. The reheating energy demand is 28341 kWh. The heat gain from the supply air fan is 4699 kWh. The total CO₂ emissions is 12447 kg. The total life cycle sum is 155118 EUR.

The indirect adiabatic cooling is compared with compressor cooling in the Table 13.

Table 13. IAC and compressor cooling. Cairo, Egypt

	IAC	Compressor cooling
Annual energy demand, Cooling, kWh	79834	89093
Annual energy demand, Fans, kWh	27410	9662
Total annual CO ₂ emissions, kg	30599	20984
LCC, Cooling, EUR	99491	111030

The annual cooling energy demand and LCC of IAC is on 10.4 % smaller than demand and cost of compressor cooling. But using heat recovery we need extra energy for fans. Therefore the annual fans energy demand is on 64.7 % bigger than demand of compressor cooling. Total annual CO₂ emissions demand of IAC is on 31.4 % smaller than emissions of compressor cooling.

The coefficient of performance (=COP) for heat recovery is:

$$\text{COP} = \frac{E_R}{E_E} = \frac{24618 + 45023}{27410 - 9662} = 3.92$$

The COP is quite high. It means that the air-conditioning system is efficient.

6 DISCUSSION AND CONCLUSIONS

This chapter discusses the results of indirect adiabatic cooling simulation in different climate. The advantages and disadvantages of this system are described in comparison to compressor cooling. Also the recommendations and ways to improvements are pointed.

The indirect adiabatic cooling was compared with compressor cooling in order to estimate its energy efficiency (see Tables 5, 9 and 13). It is obvious that the energy demand and LCC costs of compressor cooling is bigger than IAC. CO₂ emissions of IAC system is bigger than CO₂ emissions of compressor cooling in hot climate because IAC requires extra energy for fans and reheaters.

The COP is quite high. It means that the considered air-conditioning system is efficient.

Indirect adiabatic cooling is not the ideal system as the relative humidity of supply air is too high. This problem can be solved by using:

- an additional air treatment function consisting of a heater, a cooler and a re-heater (this procedure has a large impact on the energy consumption);
- desiccant systems that consist of a combination of air dehumidification and indirect adiabatic cooling

Under the right conditions and applications, IAC provides cooling and ventilation with minimal energy consumption. It uses water as the working fluid and avoiding the use of ozone-destroying refrigerants. Manufacturers and specialists should become better informed about IAC because of opportunities to decrease the use of refrigerants, to reduce CO₂ emissions that come from energy efficiency of the technology, to mitigate problems of peak electricity demand during the hot season in many countries. It is an ideal partner technology for displacement ventilation. The efficiency of using IAC depends on the particular applications and on the local climatic conditions. IAC is most suited to dry hot regions, although technical improvements such as desiccant-assisted systems. On the other hand, some applications of IAC are suitable even in humid climates.

BIBLIOGRAPHY

1. Edgar Beck. Cooling recirculation air adiabatically. Hoval. PDF-document: http://www.hoval.com/docs/Hallenklima_pdf/Cooling_recirculation_air_adiabatically.pdf. No update information available. Referred 30.09.2009.
2. Platts, a division of The McGraw-Hill Companies, Inc. HVAC: Evaporative Cooling. PDF-document: http://www.reliant.com/en_US/Platts/PDF/P_PA_42.pdf. No update information available. Referred 14.10.2009.
3. John Zellweger. Air filter and cooler. U.S. patent 838602. 1906.
4. Bryant Essick. Pad for evaporative coolers. U.S. patent 2391558. 1945.
5. Maisotsenko Valery S, Gershuni Alexandr N. Method for indirect-evaporative air cooling. U.S. patent 4977753. 1990.
6. Адиабатическое охлаждение. С.О.К. Сантехника, отопление, кондиционирование. (Adiabatic Cooling. SE.H.AC. Sanitary engineering, heating, air-conditioning). Website: <http://www.c-o-k.com.ua/content/view/1936/42/>. Update 11.09.2009. Referred 27.01.2010.
7. Типовой ряд: 55/56 Adsolair solVent. Мартена. (Type 55/56 Adsolair solVent. Martena). PDF-document: http://www.martena.net/uploads/editbar/File/Catalog%20Menerga/Adsolair%2055_56.pdf. No update information available. Referred 07.02.2010.
8. Adsolair. Double recuperative air conditioning unit for ventilation applications with two stage heat recovery and “adiabatic” evaporative cooling. Type: 55/56 Adsolair solvent. PDF data sheet Type: 55/56. Menerga. PDF-document: http://www.menerga.com/fileadmin/redaktion/Deutschland/Muelheim/Deckblatt_55-56_Engl.pdf. No update information available. Referred 07.02.2010.
9. Haderer Carol. Технологии увлажнения воздуха: оптимальный выбор. Часть II: адиабатическое увлажнение. С.О.К. Сантехника, отопление, кондиционирование. (Air humidifier technology: the optimal choice. Part II: adiabatic cooling.

SE.H.AC. Sanitary engineering, heating, air-conditioning) Vol. 6. 2007. Website: <http://www.c-o-k.ru/showtext/?id=1702>. No update information available. Referred 21.02.2011.

10. Energy Calculation and Life Cycle Cost. LCC brochure. Fläkt Woods Group. 2008. PDF-document: <http://www.flaktwoods.com/9a92c8e6-767a-4249-83e4-804bf5449b08>. No update information available. Referred 14.03.2011.

11. ACON. Fläkt Woods. Computer programme. Used 10.02.2010 – 29.03.2011.

12. СНиП 2.04.05-91. Отопление, вентиляция и кондиционирование. Введен 01.01.1992. Взамен СНиП 2.04.05-86. (Russian Building Standard 2.04.05-91: Heating, ventilation and Air-conditioning. Imposed 01.01.1992. Instead of Russian Building Standard 2.04.05-86).

13. СНиП 41-01-2003. Отопление, вентиляция и кондиционирование. СантехНИИпроект. Введен 01.01.2004. Взамен СНиП 2.04.05-91. (Russian Building Standard 41-01-2003: Heating, ventilation and Air-conditioning. Imposed 01.01.2004. Instead of Russian Building Standard 2.04.05-91).

14. D2 National Building Code of Finland: Indoor Climate and Ventilation of Buildings Regulations and Guidelines 2003. Ministry of the Environment Housing and Building Department. Helsinki. 30.10.2002.

15. B.W. Olesen, Ph.D. Introduction to the new revised draft of EN ISO 773. Wirsbo-VELTA GmbH, Norderstedt, Germany. PDF-document: http://nceub.commoncense.info/uploads/Paper04_Olesen.pdf. No update information available. Referred 29.03.2011.

16. W.J. Yu, K.W.D. Cheong, Risto Kosonen, Y.H. Xie, H.C. Leow. A thermal comfort study on displacement ventilation in the tropics. Thermal Comfort. Proceedings: Healthy Buildings 2003. PDF-document: [http://www.halton.com/halton/images.nsf/files/BAA9898B86A773C7C22571B0002593FA/\\$file/DV%20thermal%20comfort%20study.pdf](http://www.halton.com/halton/images.nsf/files/BAA9898B86A773C7C22571B0002593FA/$file/DV%20thermal%20comfort%20study.pdf). Referred 29.03.2011.

17. Displacement ventilation system. Halton. PDF-document:
[http://www.halton.com/halton/images.nsf/files/49663CE16DAB10A5C2257244002F0A3B/\\$file/displacement_design_guide_en.pdf](http://www.halton.com/halton/images.nsf/files/49663CE16DAB10A5C2257244002F0A3B/$file/displacement_design_guide_en.pdf). Referred 18.03.2011.

Appendix 1. Model of Air-handling Unit with Two-stage Indirect Adiabatic Cooling

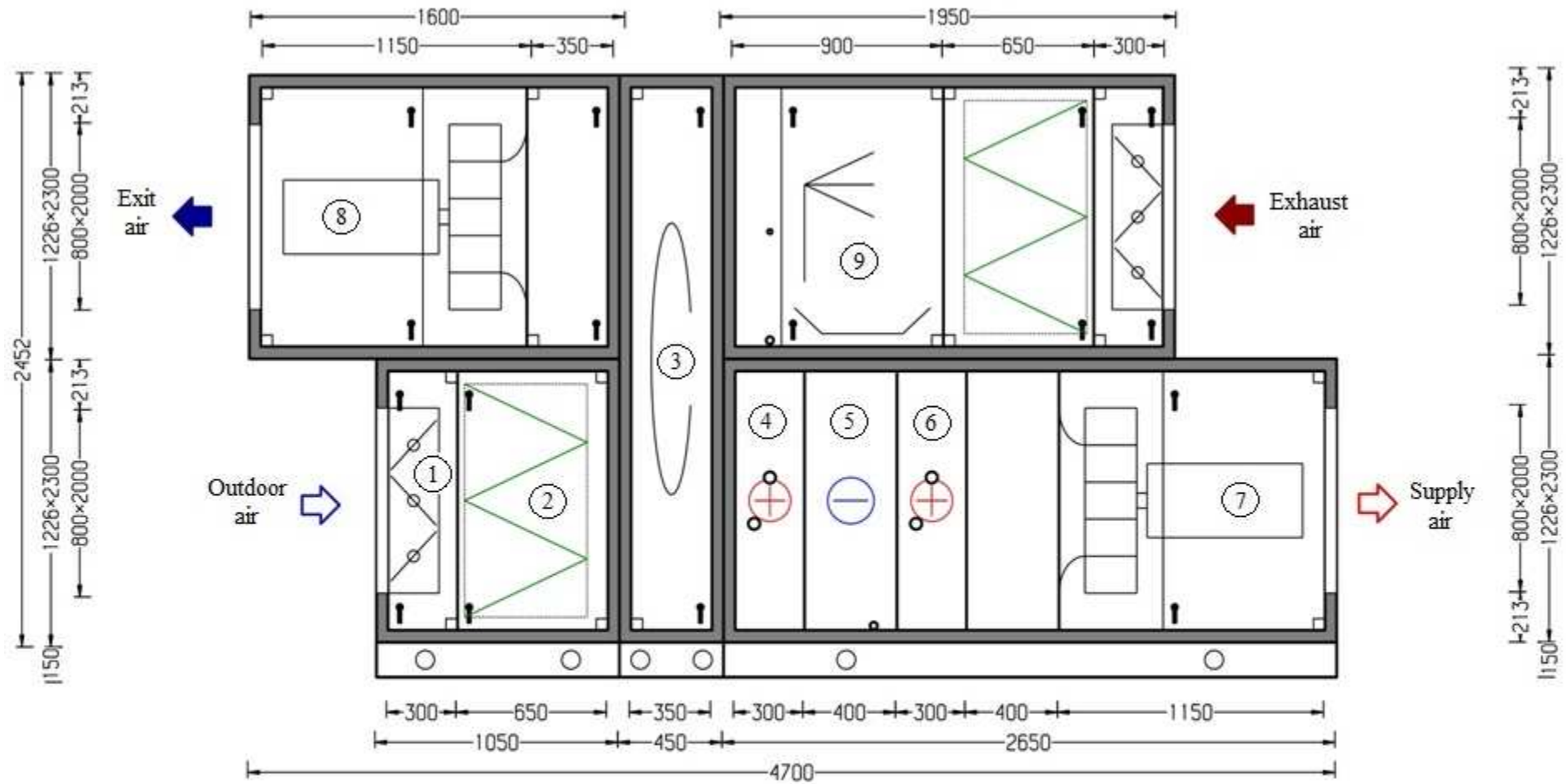

- | | |
|--------------------------|--------------------------------|
| 1. Damper on end wall | 6. Air reheater |
| 2. Filter | 7. Exit air fan |
| 3. Rotary heat exchanger | 8. Supply air fan |
| 4. Air heater | 9. Air humidifier, evaporative |
| 5. Air cooler | |