

small PRESENT

ITEMS FOR THE SMALL PRESENT SERIES

MIWA ISHIZUKA

ITEMS FOR THE SMALL PRESENT SERIES

Miwa Ishizuka

Graduation Project of Furniture Design

Bachelor's Degree Programme in Design

Institute of Design

Lahti University of Applied and Sciences,

Finland

Spring 2009

TIIVISTELMÄ

Opinnäytetyöni ideana oli kasvattaa suunnittelemani 'Small present' syömäpuikkotelineen rinnalle yhtenäinen tuoteperhe.

Suomalaista ja japanilaista suunnittelua yhdistävät ajattomuus ja yksinkertaisuus. Yhtenäisistä piirteistä huolimatta ne eroavat toisistaan hyvinkin paljon.

Projektin tavoitteena oli suunnitella suomalaisille astiasto japanilaisen ruoan nauttimiseen.

Tavoitteeni oli, että tuotteet auttaisivat nauttimaan japanilaisesta ruoasta. Tuotteiden tulisi olla yhdisteltävissä suomalaisiin astiastoihin, joita ihmisillä on jo kotona. Suunnittelin 'Small Present' syömäpuikkotelineen rinnalle pienen lautasen, soijakastikkeen kaatimen, sushin tarjoilulautasen ja tarjoittimen.

Materiaalit ovat keramiikkaa ja puuta, jotka ovat kestäviä ja käytännöllisiä materiaaleja. Nämä materiaalivalinnat olivat myös luontevia ajatellen suomalaista keittiötä. Käytännöllisyys ja käytettävyys olivat suuressa roolissa suunnitellessani tuotteita.

Olen tyytyväinen projektin kautta syntyneisiin tuotteisiin. 'Small Present' on nyt toimiva ja käytännöllinen tuoteperhe.

Muotoiluinstituutti
Muotoilun koulutusohjelma
Kalustemuotoilu
opinnäytetyö AMK
Miwa Ishizuka
sivuja 120
Kevät 2009

AVAINSANAT : - SMALL PRESENT - POHJOISMAALAINEN - JAPANILAINEN - MODERNI - YKSINKERTAINEN -

ABSTRACT

The idea of my graduation project was to design more items for the 'Small Present' tableware series which I had designed previously.

Finnish and Japanese design seem to share the appreciation of simplicity and timelessness. Yet, they are not alike.

My aim of this project was to design basic tableware on which Japanese meals could be enjoyed by Finnish people.

The aim of my design was that the items would help persons to enjoy Japanese meals. The items would suit Finnish tableware, which people have at home in Finland.

I designed new items such as a mini plate, a soy sauce pot, a sushi plate (sushi serving plate) and a tray for the 'Small Present' tableware series presented earlier. The materials are ceramics and wood which are useful for tableware, and very familiar to Finnish people. Practicality and usefulness were my key words in the design process.

As a result of the project, I was happy to present were functional items for my 'Small Present' series.

Institute of Design
Bachelor's Degree Programme in Design
Furniture Design
Graduation Project
Miwa Ishizuka
pages 120
Spring 2009

KEYWORDS : - SMALL PRESENT - SCANDINAVIAN - JAPANESE - MODERN - SIMPLE -

CONTENTS

1. INTRODUCTION _____	6.	6. DESIGN PROCESS _____	43.
2. Small Present _____	7.	6-1. the starting point of the design process	
2-1. about 'Small Present'		6-2. the beginning thoughts	
2-2. shops		6-3. ideas and prototypes	
3. FINLAND and JAPAN _____	13.	7. THE FINAL PRODUCTS _____	95.
3-1. similarity and difference		7-1. items	
how much similarity is there between the two cultures?		7-2. use of the items	
3-2. food - the culture of food -		8. EVALUATION _____	116.
3-3. tableware		SOURCES and PHOTOS _____	118.
3-3-1. the culture of tableware		ATTACHMENTS	
3-3-2. existing products			
3-4. table manners			
4. SUSHI _____	27.		
4-1. about sushi			
4-2. soy sauce			
4-3. sushi dishes			
5. GOAL and THE FINAL BRIEF _____	35.		
5-1. visual goals			
5-2. functional goals			
5-3. other goals			
5-4. the brief			

INTRODUCTION

In recent years, sushi has become popular also in Finland. I believe that there are many people who are interested in making sushi by themselves. However, it is true that most people do not have the tableware appropriate for a sushi meal. It is also difficult to know, how to eat sushi the right way. I think it is useful that the tableware can tell us how to use them and how to eat sushi the right way.

It is generally thought that sushi is food for special occasions such as a celebration. Instead, there are a lot of good sushi restaurants in Japan, and people can have delicious and fresh sushi there. In today's Japan, people do not usually make sushi at home. Still, there are also people who prefer making sushi at home. The process of ordering sushi is a performance in itself. In the hands of an expert chef, sushi is also a feast for the eyes. Sushi can also be delivered to the home the same way as a pizza.

The aim of this project is to design new items for the 'Small Present' series which is sold at the moment in stores. So far the series has consisted of a chopstick rest that I designed in 2006.

SMALL PRESENT

ABOUT THE SMALL PRESENT

small present

Chopstick Rest

material : wood
(Finnish white birch, heat-modified birch)



ABOUT THE SMALL PRESENT

The 'Small Present' is an item which includes 6 chopstick rests in a wooden case made of Finnish white birch and heat-modified birch. The chopstick rest can be used in several ways as shown in the following pictures.

The item looks very simple and beautiful, and is also very functional, which is typical to Finnish and Japanese design. The item is a mixture of Finnish and Japanese design.

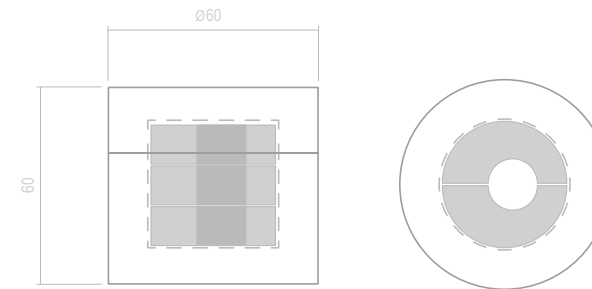

ABOUT THE SMALL PRESENT



SHOPS

Nov. 2008- : "Design Forum Finland"- design shop in Helsinki
www.common-helsinki.com

Aug. 2008- : "common"- Japanese design and lifestyle shop in Helsinki
www.designforum.fi

Feb. 2008- : "ARTEBIA"- Finnish design and crafts shop in Helsinki
www.artebia.fi



ARTEBIA



common

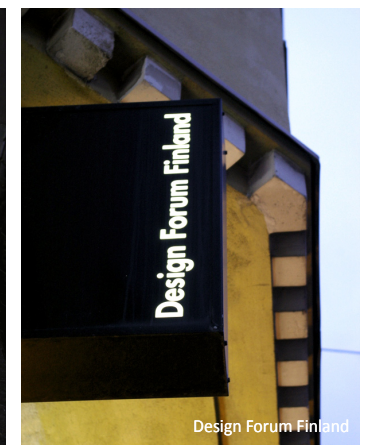

Design Forum Finland

FINLAND AND JAPAN

FINLAND AND JAPAN

SIMILARITIES and DIFFERENCES

How much similarity is there between the two cultures?

- simple (object)
 - functional (object)
 - shy (personality)
- weather
 - language
 - nationality

about food

- both eat raw material of food
- preserved food
(Finnish-pickles, frozen / Japanese-dried)

about food

- freshwater fish (Finland) / saltwater fish (Japan)
- low-fat milk products (Finland)
- people who have food allergies (Finland)

way of cooking

- mainly oven (Finland) / stove (Japan)

FINLAND AND JAPAN

FOOD

- oven meal
- wholemeal products (rye, barley, oats)
 - potato (mashed potato)
 - salmon (smoked, gravlax)
 - pickled herring
- sour milk products_viili, rahka, piimä,,,,
- berries

- pot meals
- rice
- noodle
- seafood (raw fish, dried fish)_sashimi, sushi,,,,
- seaweed
- soy beans products_tofu, soy sauce, miso,,,,



Culture of FOOD

Finnish food is generally simple, fresh and healthy. The staple food in Finland is bread (rye bread) and potatoes.

Traditional Finnish cuisine shares a lot with Swedish, German and Russian cuisines. However, there are differences in the preparation techniques: for example, Finnish dishes tend to be less sweet than Swedish ones.

Modern Finnish cuisine combines traditional country fare and haute cuisine with contemporary continental style cooking. Fish and meat play a prominent role in traditional Finnish dish from the western part of the country, while the dishes from the eastern part

Japanese cuisine has developed over the centuries as a result of many political and social changes. In the early modern era massive changes took place that introduced non-Japanese cultures, most notably Western culture, to Japan.

Japanese cuisine is known for its emphasis on seasonality of food (*shun*), the quality of ingredients and the way food is presented. This is based on combining staple foods (*shushoku*), typically rice or noodles, with a soup, and *okazu* - dishes made from fish, meat, vegetable, tofu and the like, designed to add flavor to the staple food. These are typically flavored with dashi, miso, and soy sauce

FINLAND

JAPAN

SIMILARITY

DIFFERENCE

FINLAND AND JAPAN

have traditionally included various vegetables and mushrooms, of which especially the latter were introduced to the dining tables of the western side as late as during World War II by the refugees from Karelia. In the new Finnish kitchen, dishes are lighter, smaller, and generally contain several different vegetables. This mode of cooking is highly influenced by European and American cuisine.

Nowadays, the traditional dishes are rarely eaten on a daily basis. These are often regional, associated with the older generations or confined to a specific holiday (for example, *mämmi* at Easter), and most people eat them rarely or not at all.

Rye bread (*ruisleipä* or *hapanleipä* (sour bread) in Finnish) is a dark, sour bread produced in quantity in Finland. It is the most popular type of bread in Finland.



There are three meals per day: breakfast, lunch and dinner. It is general at breakfast to eat open sandwiches. The sandwich is often made with butter (or with margarine), with toppings such as cheese, sliced tomato, sliced cucumber, ham and so on. Finns usually do not have sweets on their breads such as jam (like the French and the Americans), or chocolate (like the Danes). Sour milk products such as yogurt or viili are also common breakfast foods, usually served with cereals such as corn flakes, muesli, and sometimes with sugar, fruit or jam. A third food that is commonly eaten at breakfast is porridge (*puuro*), often made of rolled oats, and eaten with a pat of butter (*voisilmä*) and/or with milk, or fruit

FINLAND

and are usually low in fat and high in salt. A standard Japanese meal generally consists of several different *okazu* accompanying a bowl of cooked white Japanese rice (*gohan*), a bowl of soup and some *tsukemono* (pickles). The most standard meal comprises three *okazu* and is termed *ichijū-sansai* (one soup, three sides). Different cooking techniques are applied to each of the three *okazu*; they may be raw (sashimi), grilled, simmered (sometimes called boiled), steamed, deep-fried, vinegared, or dressed.

It is not an exaggeration to say that Japanese will eat the processed soy products the most in the world. For example, soy sauce, miso (soybean paste), tofu and so on.



As Japan is an island nation the people eat much seafood. Meat-eating has been rare until fairly recently due to restrictions placed upon it by Buddhism. However, strictly vegetarian food is rare since even vegetable dishes are flavored with the ubiquitous dashi stock, usually made with *katsuobushi* (dried skipjack tuna flakes). An exception is *shōjin ryōri*, vegetarian dishes developed by Buddhist monks. However, the advertised *shōjin ryōri* usually available at public eating places includes some non-vegetarian elements. Noodles are an essential part of Japanese cuisine usually as an alternative to a rice-based meal. *Soba* (thin, grayish-brown noodles containing buckwheat flour) and *udon* (thick wheat noodles) are the main traditional noodles and are served hot or cold with soy-dashi flavorings. Chinese style wheat noodles served in a meat stock broth known as *ramen* have become extremely popular over

JAPAN

FINLAND AND JAPAN



or jam, especially the sort made of raspberries or strawberries. Drinks are milk, juice, tea, or coffee.

In all primary and secondary schools, including high school, a hot free lunch is served as part of Finland's welfare state agenda. At the university, there are cafeterias where student scan eat by the student charge. Among workers, lunch is often not so heavy, and may be a sandwich or a salad. In the evening, dinner is usually a hot meal.

(http://en.wikipedia.org/wiki/Cuisine_of_Finland)

As an extra remark, coffee is a very popular drink in Finland. Finns drink are the heaviest coffee drinkers in the world, with their habit of drinking it several times a day.

FINLAND

the last century.

Japan has incorporated imported food from across the world (mostly from Asia, Europe and to a lesser extent the Americas), and has adapted many to make them their own.



Japan today abounds with home-grown, loosely western-style food. Western cuisine is opening up in cities. Many Western cuisine items have been adapted to the degree that they are now considered Japanese and are an integral part of any Japanese family menu. Many are served alongside rice and miso soup, and eaten with chopsticks. Yet, due to their origins, these are still categorized as Western cuisine as opposed to the more traditional Japanese cuisine.

(http://en.wikipedia.org/wiki/Japanese_cuisine)

JAPAN

FINLAND AND JAPAN

TABLEWARE

- the whole meal on one plate
- cutlery



- one dish on one plate
- chopsticks



materials

- porcelain (china)
 - pottery
 - glass (crystal)
 - wood (e.g. birch)
 - stainless steel
 - silver
 - plastics
- porcelain (china)
 - earthenware
 - glass (crystal)
 - wood (e.g. bamboo)
 - stainless steel
 - Japanese lacquer

FINLAND

JAPAN

FINLAND AND JAPAN

Culture of TABLEWARE

Finnish tableware is simple and useful typical of Finnish products. For example, Kaj Franck is very known for this style. He worked for Arabia which is the most important ceramics factory in Finland. 'Kilta', designed by him, was first produced in 1948, and is still being produced today. It is updated only for its usability in a microwave. It was relaunched in 1981 as 'Teema'. This series is very popular among Finns as well as abroad. Typical Finnish tableware is practical long-lasting and durable (thick cups as an example). Therefore, it is always dishwasher-proof.

In daily life, Finns usually use one plate for their meal with knife and fork or spoon. This is a very common style for them. Japanese people usually use separate cups, plates or bowls for each different part of a meal.

Many different materials of tableware such as lacquer ware, earthenware, and porcelain, etc. are used together in Japan. Traditional tableware is printed in various ways. Especially, earthenware is greatly different from the tableware of traditional European and American one. For example, it can imitate the shape of a flower or a fruits, or the plate can have a square shape or a very deep color. Japanese earthenware is very different from Chinese and South Korean tableware, where the history of pottery production exists.

Moreover, before pottery spread, a wooden bowl was used in Japan. Still today, there is wooden, lacquered tableware in Japan used for many purposes.

At home, everyone usually has their own individual rice bowls and chopsticks.

The rice bowl develops originally from the tea culture of China. This can still be detected in the Japanese name for the rice bowl 'chawan' which actually means tea bowl.

The first porcelain that arrived in Japan in the 17th century was called the Arita ware of the Saga Prefecture.

TEEMA, Kaj Franck, Arabia



FINLAND

JAPAN

rice bowl, Arita



TABLEWARE

FINLAND



Sahrami: Kermansavi

TEEMA, Kaj Franck: Arabia

Warm : Tonfisk

<http://www.tulikivi.com/>

<http://www.finnishgifts.com/iittala-teema-dinnerware.html>

<http://www.tonfisk-design.fi>



<http://designholeonline.com/tag/designers>



Ultima Thule, Tapio Wirkkala: Iittala

<http://www.mtv3.fi/koti>



Ote, Aleksi Perälä: Iittala

<http://www.mtv3.fi/koti>

Citterio 98, Antonio Citterio and Oliver Löw, Iittala



<http://www.fitchfindings.co.uk/kitchen.html>

<http://www.allmodern.com/Citterio-98-Cutlery-Series-IIT1146.html>



<http://itrademarket.com>



<http://www.aarikka.fi/en.php?k=8578>

- fork & knife, spoon
- plate
- bowl (salad, soup)
- napkin
- glass (e.g. water, milk, juice beer, wine)
- tea cup, coffee cup
- ovenware
- cheese plate, knife, slicer
- salad server
- butter knife
- teapot
- tray
- salt & pepper

TABLEWARE

JAPAN

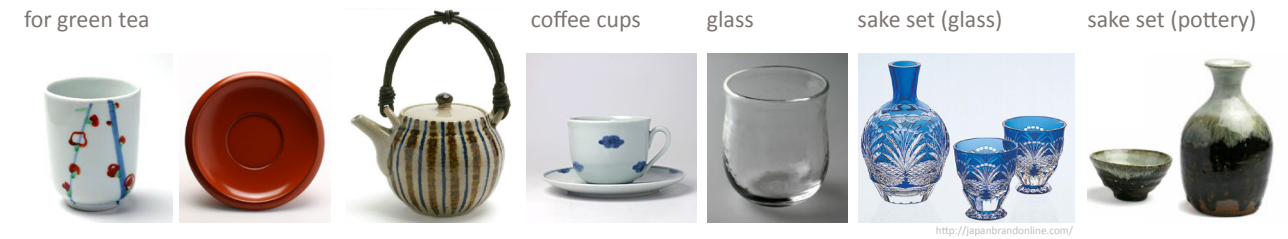

for green tea

coffee cups

glass

sake set (glass)

sake set (pottery)

rice bowl and soup bowl

bowls



plates



others



All the other photos on this page; <http://www.rakuten.ne.jp/gold/yobi/>

- chopsticks
- plate
- bowl (e.g. rice, soup)
- glasses (e.g. water, sake, beer)
- teacup, coffee cup
- teapot
- tray
- soy sauce pot
- chopstick rest
- earthen pot

TABLE MANNERS

Daily life

Table manners in Finland are basic European - hold the fork in the left hand and the knife in the right while eating. Each person takes the meal from the table to one's plate themselves, except children.

Dinner party

At a formal dinner party, the host determines the seating order if necessary. The guest of honour is seated to the right of the hostess (or the host, if it is a men-only dinner). This is a seat dreaded by most Finns, since the guest of honour is expected to say a few words of thanks to the hosts after the meal. Guests should not begin to eat until everyone has been served; usually, the host will propose a toast at the beginning of the meal, wishing his guests *hyvää ruokahalua*, the Finnish for bon appétit!



<http://www.allaboutyou.com/>

It is not appropriate for guests to drink before this, unless the beginning of the meal is badly delayed. Finns seldom make speeches during the meal except for formal occasions. In such cases, the speeches are made between the courses. Usually, however, speeches are given immediately after the meal. When leaving the table, the guests

FINLAND

Tables and sitting

In Japan, some restaurants and private homes have low tables and cushions on the floor, rather than Western style chairs and tables. These are usually found on tatami floors.



<http://japanhouses.net>

Itadakimasu and Gochisosama

In Japan, people say "itadakimasu" ("I gratefully receive") before eating, and "gochisosama (deshita)" ("Thank you for the meal!") after finishing the meal. This is a very important etiquette.

- Individual versus shared dishes

It is not uncommon in private households and in certain restaurants to share several dishes of food at the table rather than serving each person an individual dish. When eating from shared dishes, you move some food from the shared plates onto your own with the opposite end of your chopsticks or with chopsticks that may be provided for that purpose.



<http://mrs.allabout.co.jp>

JAPAN



<http://www.savutuvanapaja.fi/index.php?page=restaurant>

should thank the hosts briefly for the occasion when they get the chance, regardless of whether the guest of honour has done so or not. (<http://finland.fi/netcomm/news/showarticle.asp?intNWSAID=25001>)

FINLAND

Chopsticks

The proper usage of chopsticks is the most fundamental element of Japanese table manners. Chopsticks are used to eat most kinds of Japanese foods, with some exceptions. Some of the most important rules to remember when dining with chopsticks are as follows:

- When you are not using your chopsticks, or have finished eating, lay them down in front of you with the tips to left.
- Do not stick chopsticks into your food, especially not into rice. (This is done only at funerals with rice that is put onto the altar.)
- Do not pass food directly from your set of chopsticks to another's. (This is a funeral tradition that involves the bones of a cremated body.)
- Do not spear food with your chopsticks.
- Do not point with your chopsticks.
- Do not wave your chopsticks around in the air or play with them.
- If you have already eaten with your chopsticks, use the opposite end to take food from a shared plate.



<http://www.lewrockwell.com/murphy/murphy141.html>

JAPAN

FINLAND AND JAPAN

Some Table Rules

- Always keep your hands visible when eating. Keep your wrists resting on the edge of the table. Bread and shrimp are the only foods eaten by hand. Even fruit is eaten with utensils.
- Accept second helpings.
- When passing salt and pepper shakers, put them on the table within the person's reach. Do not give them directly.
- Men should keep their jacket on at meals unless the host removes his.
- Finish everything on your plate. Finns do not appreciate waste.
- When you have finished eating, place your knife and fork across your plate with the prongs facing down and the handles facing to the right.

(<http://www.kwintessential.co.uk/resources/global-etiquette/finland-country-profile.html>)

Some Table Rules

- It is considered good manners to empty your dishes to the last grain of rice. Unlike in some other parts of East Asia, it is considered a bad manner to burp.
- After eating, try to move all your dishes back to the same position they were at the start of the meal. This includes replacing the lids on dishes and putting your chopsticks on the chopstick holder or back into their paper slip.
- Both hands can be used for a meal.

SUSHI

SUSHI

about sushi

Sushi is the most famous Japanese dish outside of Japan, and one of the most popular dishes among the Japanese themselves. In Japan, sushi is usually enjoyed on special occasions, such as a celebration.

During the Edo period, “sushi” referred to pickled fish conserved in vinegar. Nowadays sushi can be defined as a dish containing rice which has been prepared with sushi vinegar. There are many different types of sushi. Some popular ones are: NIGIRI, GUNKAN, NORIMAKI, TEMAKI, OSHIZUSHI, INARI and CHIRASHI.

How to eat

- Pour some soy sauce into the small dish provided. It is considered bad manners to waste soya sauce, so try not to pour more sauce than you will use.
- There is no need to add wasabi into the soy sauce, because the sushi pieces may already contain it, or may be eaten plain. However, if you choose to add wasabi, use only a small amount.
- In general, you are supposed to eat a sushi piece in one bite. Attempts to separate a piece into two generally end in the destruction of the beautifully prepared sushi.
- In case of nigiri-zushi, dip the piece into the soy sauce down so that the fish enters the sauce. A few kinds of nigiri-zushi, for example, marinated pieces, should not be dipped into soy sauce.
- In case of gunkan-zushi, pour a small amount of soy sauce over the sushi piece rather than dipping it into the sauce.



Sushi can be eaten either by hand or using chopsticks, although traditionally nigiri is eaten with the fingers because the rice is packed loosely so as to fall apart in one's mouth, and would disintegrate on chopsticks. Condiments (soy sauce, wasabi, and pickled ginger) are used as desired.

If you must use soy sauce when eating your sushi, remember not to dip the whole sushi in. Just dip the end of the sushi as you eat. Eat some pickled ginger (called gari) between bites of sushi to refresh your mouth for each new taste.

(<http://www.japan-guide.com/e/e2038.html>)

SUSHI

Some popular sushi



Western Sushi

California roll which contains avocados and imitation crab meat that has developed into a popular sushi roll around the world. Other creations now use mayonnaise, tuna (it was not used in traditional sushi), beef, cheese and so on. These have also appeared in Japanese cuisine.



about soy sauce

Soy sauce is a fermented sauce made from soybeans, roasted grain, water and salt. Soy sauce was invented in China, where it has been used as a condiment for close to 2,500 years. In its various forms, it is widely used in East and Southeast Asian cuisines and increasingly appears in Western cuisine and prepared foods. Soy sauce is widely used as a particularly important flavoring in Japanese cuisine and food.

The soy sauce generally sold these days in Japan and abroad, is mass-produced by major companies and not good for your health, since it contains too much salt and is made in just an hour through a chemically treated fermentation process.

Positive

Chinese dark soy sauce contains 10 times the antioxidants of red wine, and can help prevent cardiovascular diseases. Soy sauce is rich in lactic acid bacteria and of excellent anti-allergic potential.

Negative

Soy sauce does not contain the beneficial isoflavones associated with other soy products such as tofu or edamame. It can also be very salty, so it may not be a suitable condiment for people on a low sodium diet.

(http://en.wikipedia.org/wiki/Soy_sauce)



SUSHI DISHES

soy sauce plate



SUSHI DISHES

soy sauce pot



GOALS AND THE FINAL BRIEF

VISUAL GOALS

mood boards



Butterfly Chair, Sori Yanagi: Tendo
<http://www.tendo-mokko.co.jp/products>



The Barcelona Chair, Ludwig Mies van der Rohe
http://www.iconicinteriors.com/our_products/category/chairs/the_barcelona_chair/



Collective Tools, Antonio Citterio, iittala
<http://www.iconicinteriors.com>

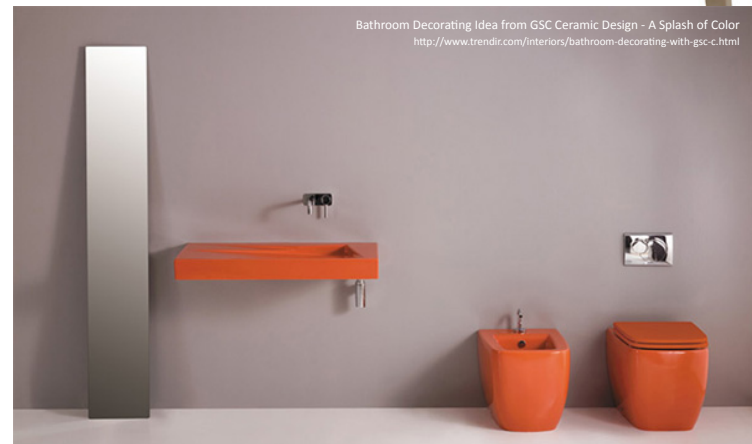

Bathroom Decorating Idea from GSC Ceramic Design - A Splash of Color
<http://www.trendir.com/interiors/bathroom-decorating-with-gsc-c.html>



secto 4200, Seppo Koho: secto Design
<http://www.sectodesign.fi>



SUMIREAOI HOUSE:
 Makoto Koizumi
http://www.koizumi-studio.jp/html_works/03_3h_9.html

- modern but timeless design - authentic (genuine) - functional - cooking -

GOALS

FUNCTIONAL GOALS

It is easily understood from the items I designed how they work and how to eat sushi with them.

If a product is not functional, it will be less used. Tableware can be used a few times in a day. I hope the items of this series will be products which are used in several ways in everyday life. The items are should easily be used in the daily life of a Finnish person, not only for having a sushi meal. The items will be easy to use and to store.

I think we always have some problems storing things. In the case of tableware, they are always in many kinds of shapes which makes it difficult to store all of them together in the same place. With my items storing should be carefully considered. The items would have to fit on a standard-sized Finnish shelf. They will be several items in this series. However, they do not always have to be use together. Each item will easily work also with other tableware which people usually have.

VISUAL GOALS

The aim of my project was to design items that would suit my previous 'Small Present' tableware. Another aim was to design items to suit Finnish tableware and Finnish way of life. I aimed to design something new but not too eccentric, something original. Of course, the visual impressions of the items are important, but tableware should assist people to enjoy the meal they are having. The items give spice to the meal (or table), not be the main issue. I had an idea of something to both Finnish and Japanese design.

OTHER GOALS

SOY SAUCE POT MAP (EXISTING PRODUCTS)

INDUSTRIAL

SIMPLE

DECORATIVE

CRAFT



THE BRIEF

Both Finnish and Japanese design seem to share a similar feature, simplicity. However, the style is not too simple, boring. They share the same kind of taste, that is not too simple either. It is timeless design.

I will design items which are used for a sushi meal.

Finally, it will result in prototypes made of the real materials.

The items can be used in everyday life for years and years. The usage of the items must be easy to discover, as well as how to eat sushi the right way.

I hope that people will have enjoyable meal times with the item of the 'Small Present' series.

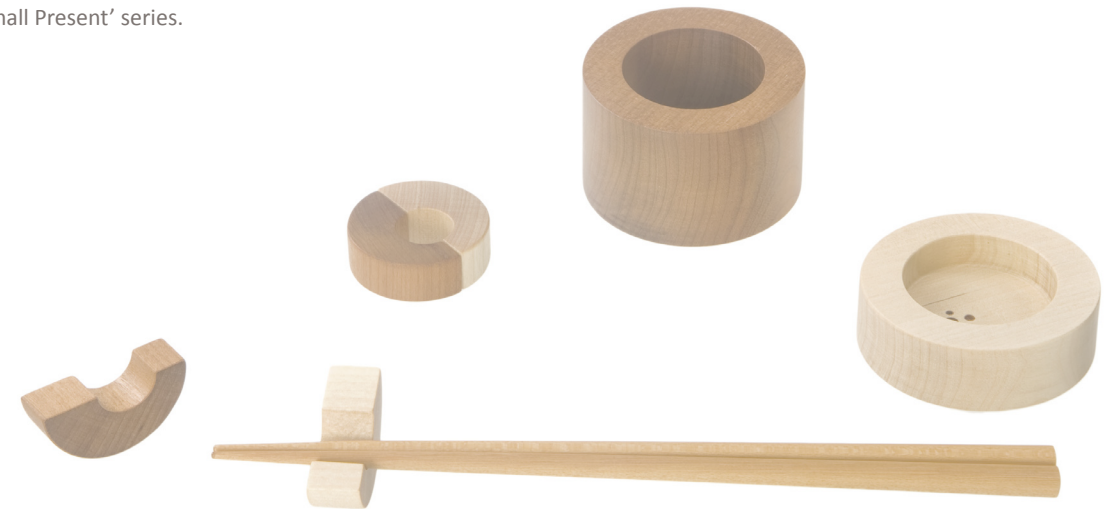

DESIGN PROCESS

STARTING POINT OF DESIGN

When I ate sushi for the first time with some of my friends who are not Japanese, I was surprised by the way they ate them. Afterwards, I felt the same every time I ate sushi several times with Finnish people. However, I was happy that they enjoyed eating sushi which is a very famous Japanese meal. But at that time, it seemed strange to me that people dipped sushi in a “soy sauce river”. It seemed like it was swimming in way too much soy sauce, which is very salty and not healthy when used it too much. This is one of the main points of my project.

I started to think about how it would be possible to take a small quantity of soy sauce with sushi from a soy sauce plate.

Soy sauce is a very common sauce in Japan. Before I moved to Finland, I did not know that soy sauce is a very common sauce and there are lots of people who like it in Finland, too. It was a kind of a culture shock to me. It is easy to find a soy sauce bottle from every kitchen here in Finland. But I have never seen a soy sauce pot here, except for Kikkoman’s one. In Finland, I think people are more interested in tableware than in other European countries. However, they do not have the pot which is used for soy sauce.



IDEAS

ITEMS

- CHOPSTICK REST (wooden) exists already
- CHOPSTICKS (wooden) design
- MINI PLATE (ceramic) design and prototype
- SOY SAUCE POT (ceramic + wood) design and prototype
- TOOTHPICKER HOLDERS (ceramic) design and prototype
- TRAY (wooden) design and prototype

CHOPSTICKS

IDEA

material : wood



CHOPSTICKS

IDEA

material : wood

When I started to think about the items for this project, chopsticks were the first item that came to my mind, because I had already designed a chopstick rest. The idea was to teach people to use chopsticks the right way, because it is not easy for non-Japanese people.

Chopsticks should be held at about 1/3 of the way down from the broad end of the stick. I designed the chopsticks so that their color changes from dark (or light) to light (or dark) at the holding point.

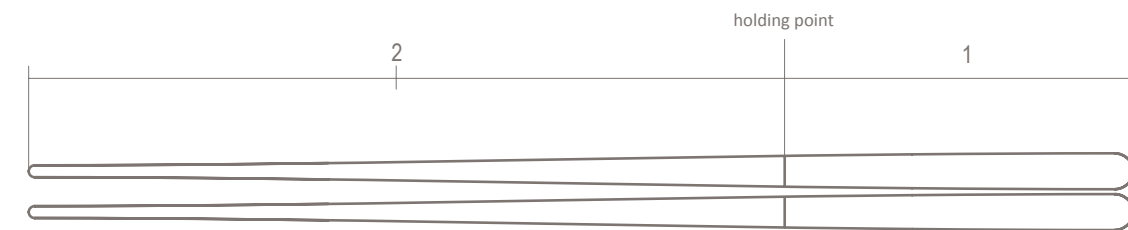

MINI PLATE

BASIC IDEA

material : ceramic



Sushi is dipped in a "soy sauce river".

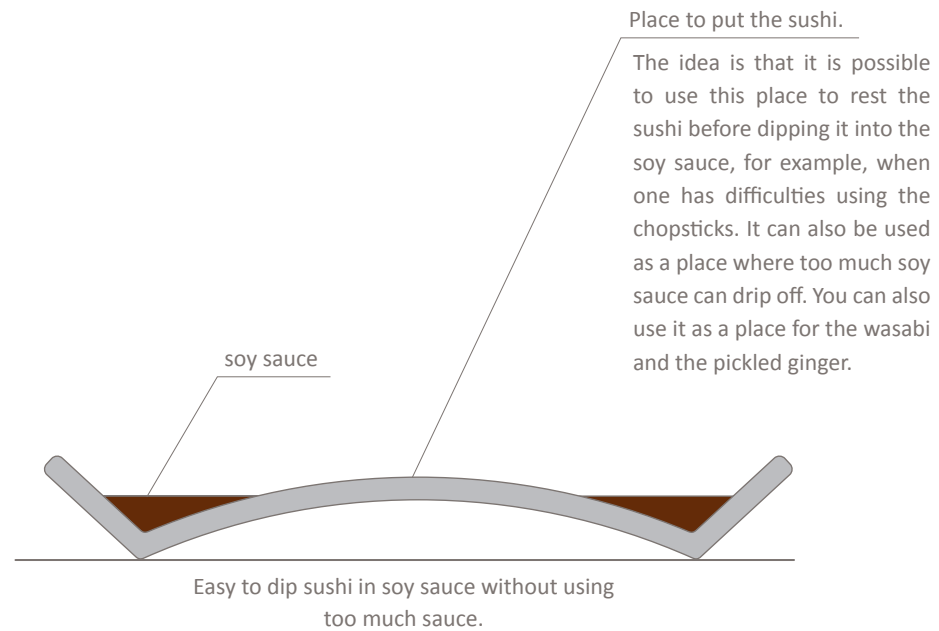

MINI PLATE

IDEA -STEP1-

material : ceramic



First, I designed a round shaped plate. I thought it suited the 'Small Present' series well. However, there was a danger of it being too monotonous with the cylinder shape of the 'Small Present'.

Then, the shape was changed to a square, which looked better than the round shape., because it created a contrast with the cylinder shape. I decided to design a basic square shaped plate. Still the shape of the bottom needed some more consideration.

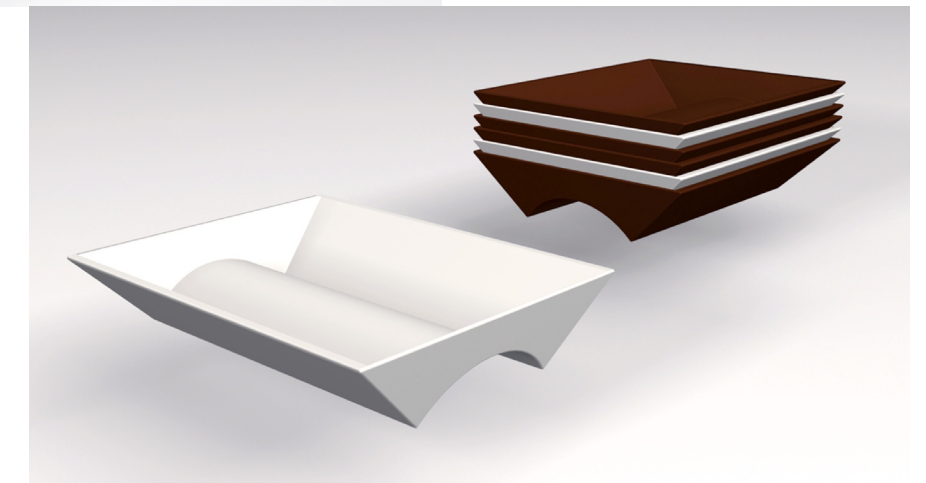

MINI PLATE

IDEA - TYPE A -

material : ceramic

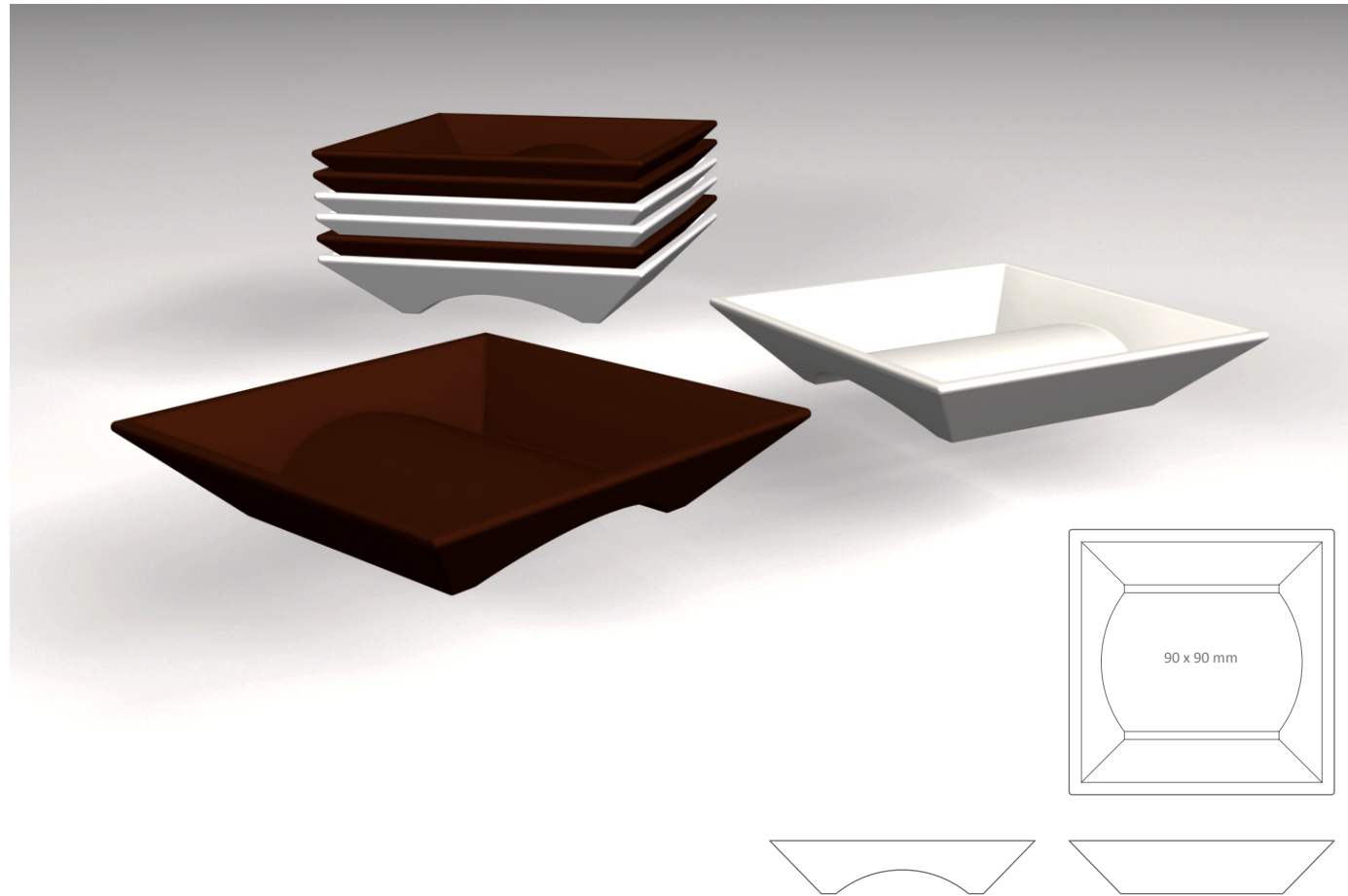

MINI PLATE

IDEA - TYPE B -

material : ceramic

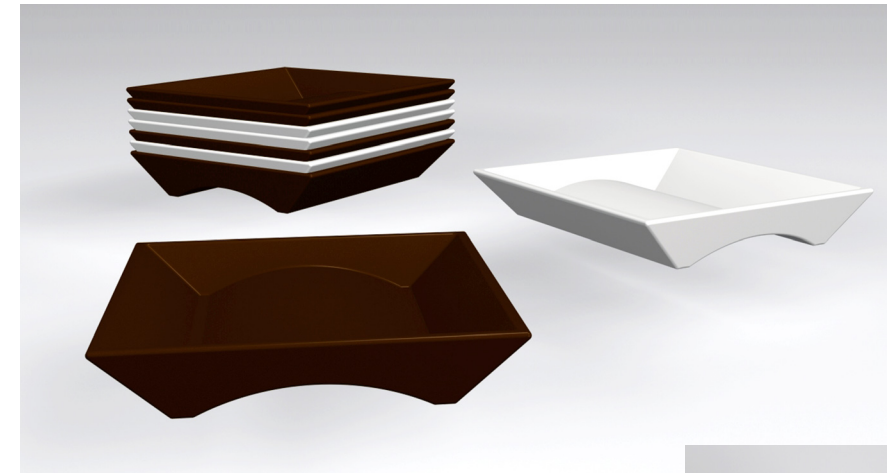

Type B appears to be bigger than A. But actually, both these plates are the same size. The only difference is, in type A the walls are more beveled that in type B.

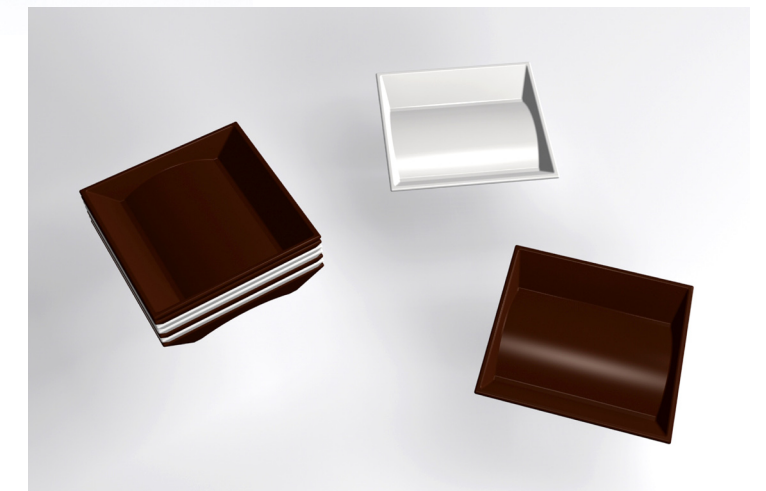
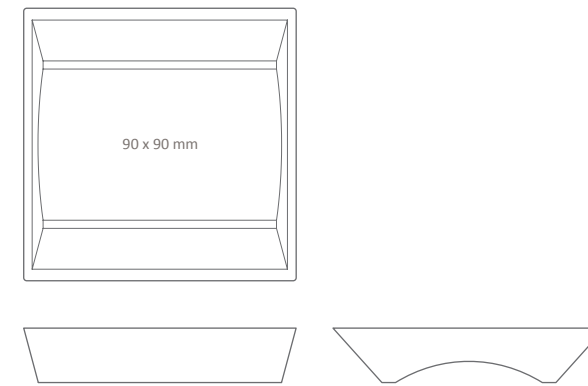

SOY SAUCE POT

IDEA -STEP1-

material : ceramic, wood



The nozzles might break easily in both these types.



The outlook differs too much from other items in the series.

I decided I would develop these designs further.



SOY SAUCE POT

IDEA -STEP2-

material : ceramic, wood



A

B

C



There are three different types of pots. The difference is in the shape of the wooden cap. I chose types B and C from these pots to the next step.

I thought that type B looked the most functional, and type C seemed to suit the 'Small Present' series.

SOY SAUCE POT

IDEA - TYPE B -

material : ceramic, wood



SOY SAUCE POT

IDEA - TYPE C -

material : ceramic, wood



SOY SAUCE POT B AND MINI PLATE B

IDEA

material : ceramic, wood



SOY SAUCE POT B AND MINI PLATE B

IDEA

material : ceramic, wood

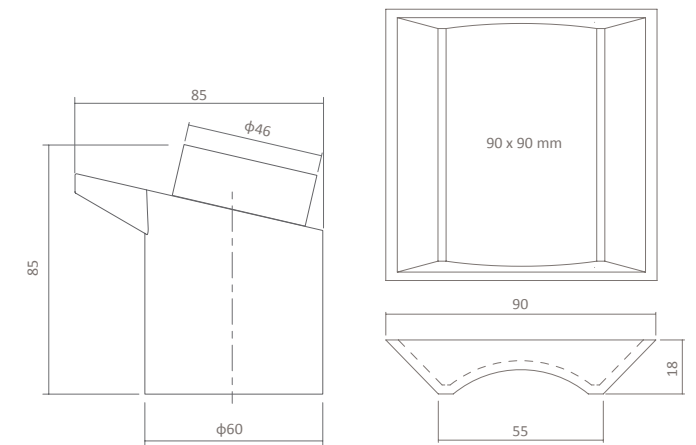

At this stage, I preferred the mini plate type B and the soy sauce pot type B rather than the type A. Therefore, I needed to see how it would work with soy sauce when made of the final materials. The next step was to make a mold of the items.

MINI PLATE

THE PROCESS OF THE CERAMIC PLATE - TYPES A AND B-

1. Cardboard models (1:1)

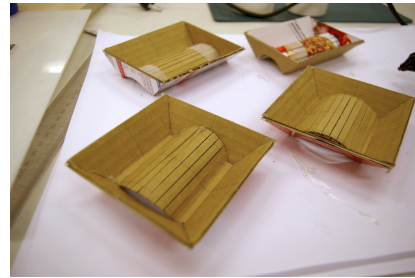
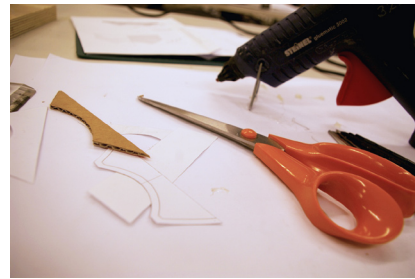

2. Modeling of the molds (plaster)

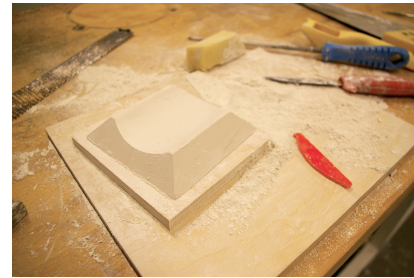
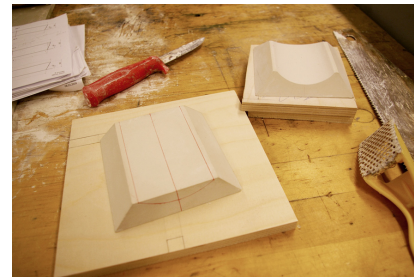

3. Molding (plaster)

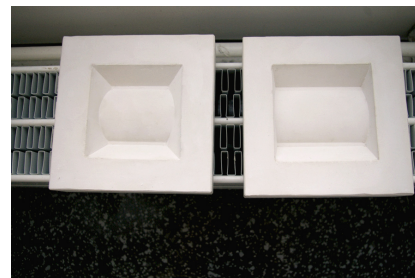
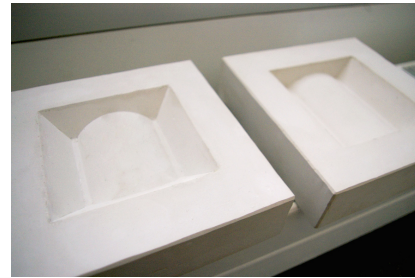

4. First prototypes (ceramic; casting)

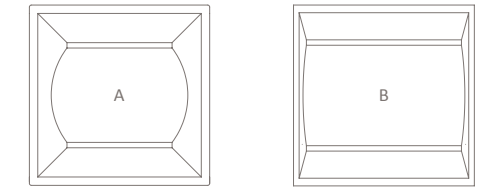

When thinking about the shape of the plate, I made several 1:1 cardboard models of the plate. This step helped me a lot in studying the shapes. Then I started to make the first prototypes of the mini plates types A and B. It was not possible to share the same mold for the plates so. I made two different models out of plaster. After that, the molds were made out of plaster. The technique of making ceramic was in this case casting.

MINI PLATE

THE FIRST SAMPLES - TYPES A AND B -

material : ceramic

One color for one plate.

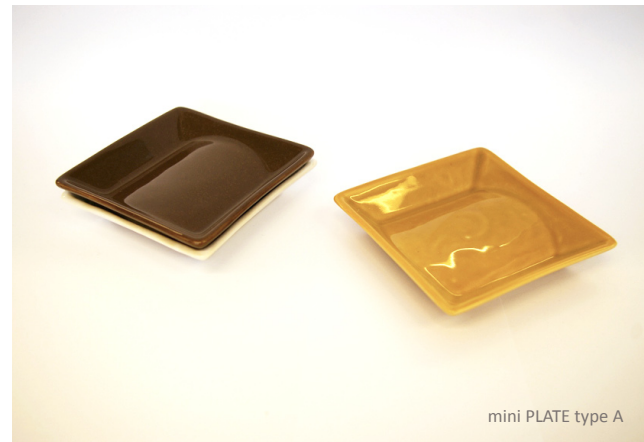

My idea of the color for the plate was something natural to fit the other items in my project. I made two different shapes of the plates in several colors: dark brown, camel and white. I also tried two different techniques of color glazing.

Inside of the plates - brown
outside of the plates - white

Two colors for one plate.

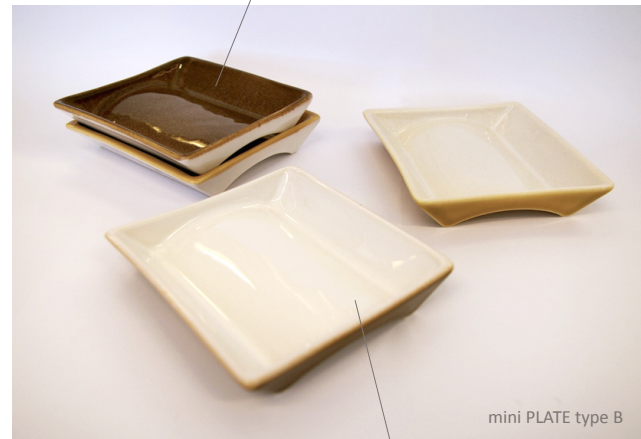

Inside of the plates - white
outside of the plates - brown

MINI PLATE

THE FIRST SAMPLES - TYPES A AND B -

TEST - COLOR PLATE WITH SOY SAUCE -

before



after

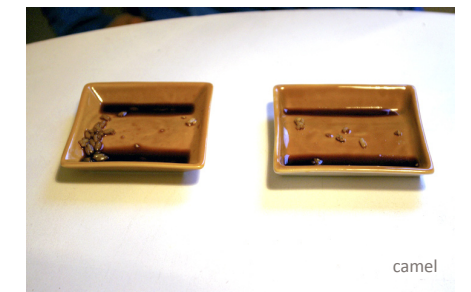

Here are three different colors of the plates. I tested the how the plates look with soy sauce.

Camel color gave us an image of something sweet. I thought this color would not fit with soy sauce and sushi.

Dark brown color appeared almost the same as the brown of the sauce. The test proved that the soy sauce was hidden by the brown of the plate. Therefore, the plate did not look messy.

White is the best color for food, because it makes food look more delicious. In my opinion it is the right color for all kinds of foods and table setting.

MINI PLATE AND SOY SAUCE POT

THE FIRST SAMPLES

TEST

After I got the first prototypes of the plates and the pots, I tried to check how they worked in various situations concerning their use.

Storage



In case of a drying rack, it works well for both items.

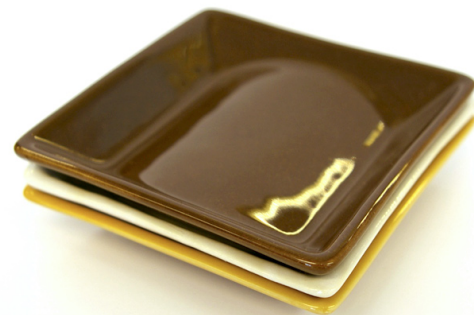

when stacking the plates, type A worked well, type B not.

MINI PLATE AND SOY SAUCE POT

THE FIRST SAMPLES

TEST

After I got the first prototypes of the plates and the pots, I tried to check how they worked in various situations concerning their use.

Pouring the soy sauce onto a mini plate.



The nozzle of the soy sauce pot worked well when pouring the sauce. But after that, the soy sauce dripped onto the table (tablecloth) from the nozzle of the pot.

The soy sauce, which is poured onto the middle of the plate, flowed to both sides of the plate. The sauce did not stay in the middle of the plate. So what I had thought, was happening: it might be that the plate would work well with sushi.

MINI PLATE

THE FIRST SAMPLES

TEST

For the different types of sushi.



Pouring the soy sauce onto a mini plate.



Nigiri by chopsticks.



Rolled sushi eaten by chopsticks.



Pouring the soy sauce onto a mini plate.



Nigiri by chopsticks



Rolled sushi on the mini plate.



dipping the sushi onto the soy sauce.



Gunkan-maki by chopsticks



Rolled sushi eaten by hands.

MINI PLATE

THE FIRST SAMPLES

TEST

About the soy sauce pot
See page 63.

After I got the first samples of the plates, I used them to check how Europeans were able to eat sushi with them. It was exciting for me. Because I am Japanese I know how sushi is eaten. I needed to know how people who are not Japanese or Asian, would be able to use the items.

I made several types of sushi which are common in Finland for the trial of the soy sauce plate and soy sauce pot.

About the mini plate

SIZE :

I thought the size of these plates could be too small for a sushi. The test proved I was wrong -the size of the plate appeared a very good size for standard sushi.

SHAPE :

When observing how people used the plates, I saw they first put the sushi which they took from a sushi plate to the middle of the mini plate. Then they dipped the sushi in the soy sauce on the mini plate. It was no longer swimming in a 'soy sauce river'.

I found another interesting point when watching European people eat sushi - the chopsticks. I know it is not easy for them to use the chopsticks. Therefore, the idea of planning the sushi in the middle of the mini plate for a while before eating it, seemed good. Afterward, I learned that Japanese people also did that. I seemed that the plate guided people to eat sushi the right way. I was assured that these plates are appropriate for sushi.

SOY SAUCE POT

THE PROCESS OF THE CERAMIC POT -TYPES B AND C-

1. The model of the mold

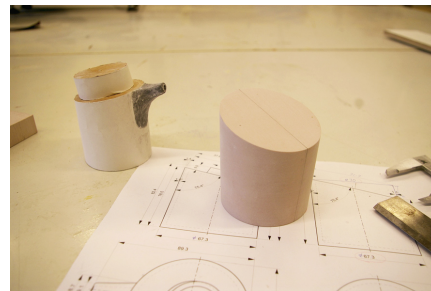

2. Molding (plaster)

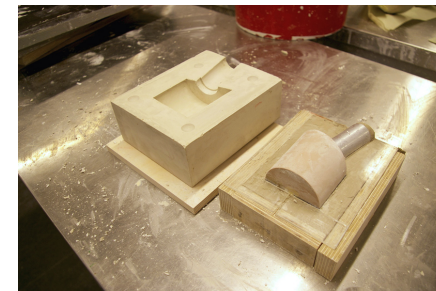

3. First prototypes (ceramic)

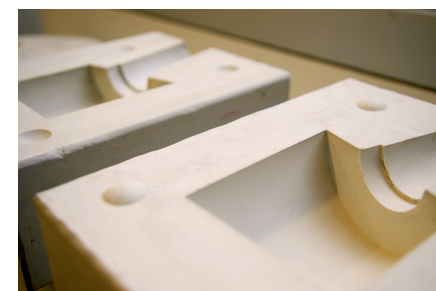
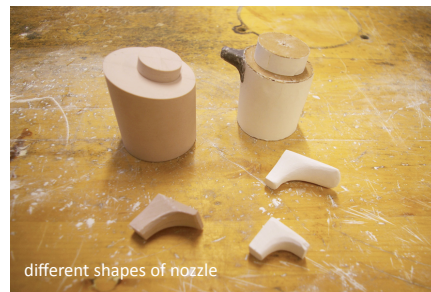
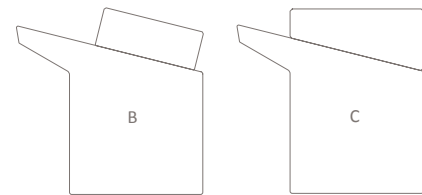
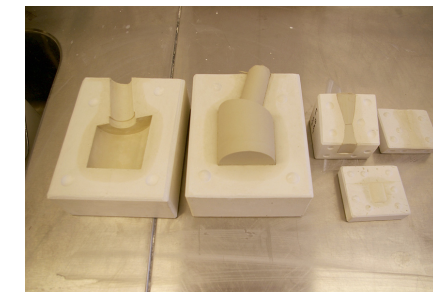

I started to make the first prototypes of the soy sauce pot of types B and C whose ceramic body is basically identical in shape. It means that these pots can share the same mold at the prototyping phase. The idea was to test how the pot would fit in one's hands and how the nozzle would work with soy sauce.

SOY SAUCE POT

THE PROCESS OF THE CERAMIC POT -TYPES B AND C-

1. The model of the mold

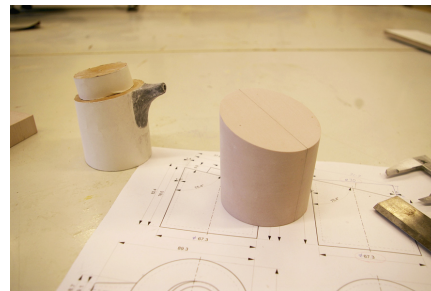

2. Molding (plaster)

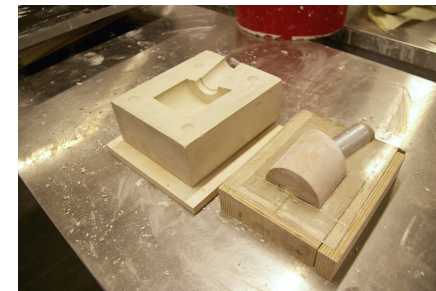

3. First prototypes (ceramic)

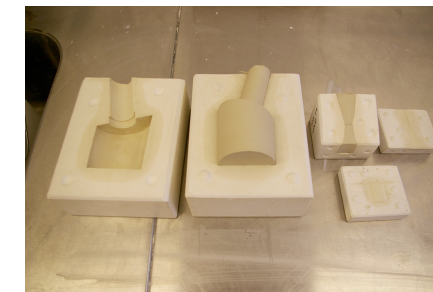

I started to make the first prototypes of the soy sauce pot of types B and C whose ceramic body is basically identical in shape. It means that these pots can share the same mold at the prototyping phase. The idea was to test how the pot would fit in one's hands and how the nozzle would work with soy sauce.

SOY SAUCE POT

THE FIRST SAMPLES - TYPES B AND C -

material : ceramic, wood



Here are the first samples of the soy sauce pot. There are two different types of the wooden caps both of which seemed to go together quite well with the 'Small Present' series. Both actually looked better than I had imagined, yet I had to choose one.

SOY SAUCE POT

THE FIRST SAMPLES OF THE VARIATION OF THE NOZZLES

different shapes of nozzles



color variation -dark brown-

I made four different soy sauce pots with different nozzles. The difference between types a and b is that the nozzle is arched and in type b it is straight. In a-1 and a-2, b-1 and b-2 the angle of the nozzle tip varies.

At the time when I was making the prototypes, I couldn't find functional differences of the nozzles regarding the usage with soy sauce. The change of angle did not have an effect on the functionality.

I thought type b which has straight line of nozzle, would suit with the mini plate. So, I have chosen type b nozzle. Here is also a dark brown sample of the type b.

TOOTHPICK HOLDER

IDEAS - TYPES A AND B -

material : ceramic

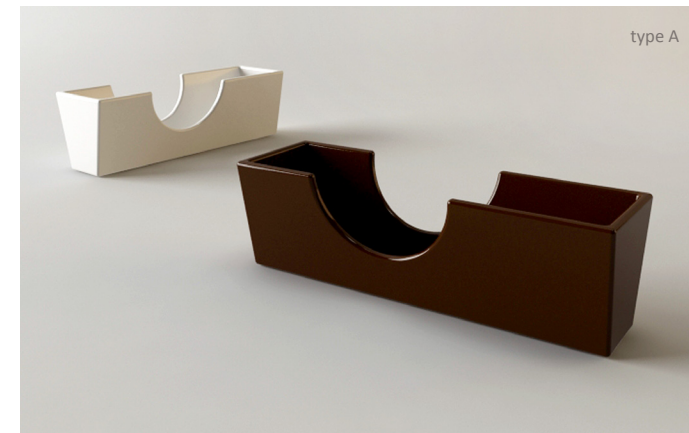

The idea of the toothpick holder was that it should be easy to take a toothpick from it. The shape originally came from the chopstick rest.

Type A is a holder for the long toothpicks.
Type B is a holder for the short ones.

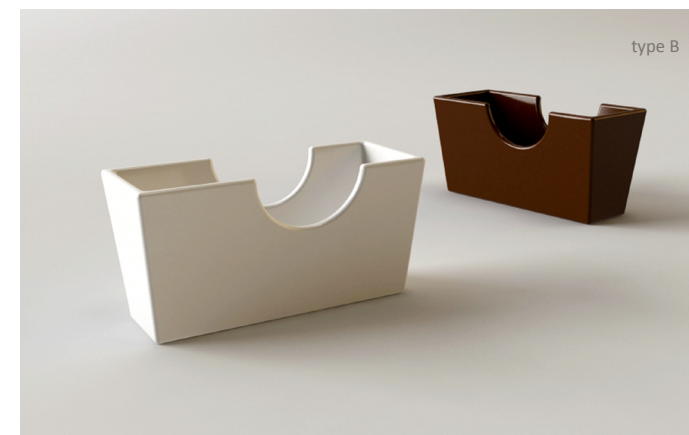

In Japan, toothpicks are generally, kept on a table in the kitchen or in the dining room. In Finland, people keep them in the bathroom.

TRAY

IDEAS -STEP1-

material : wood



The original idea of the tray was a solid wooden one. First, I designed a simple tray. Both ideas consisted only straight lines. The form seemed too hard to me.

TRAY WITH ALL THE ITEMS

IDEA -STEP1-

material : wood,ceramic

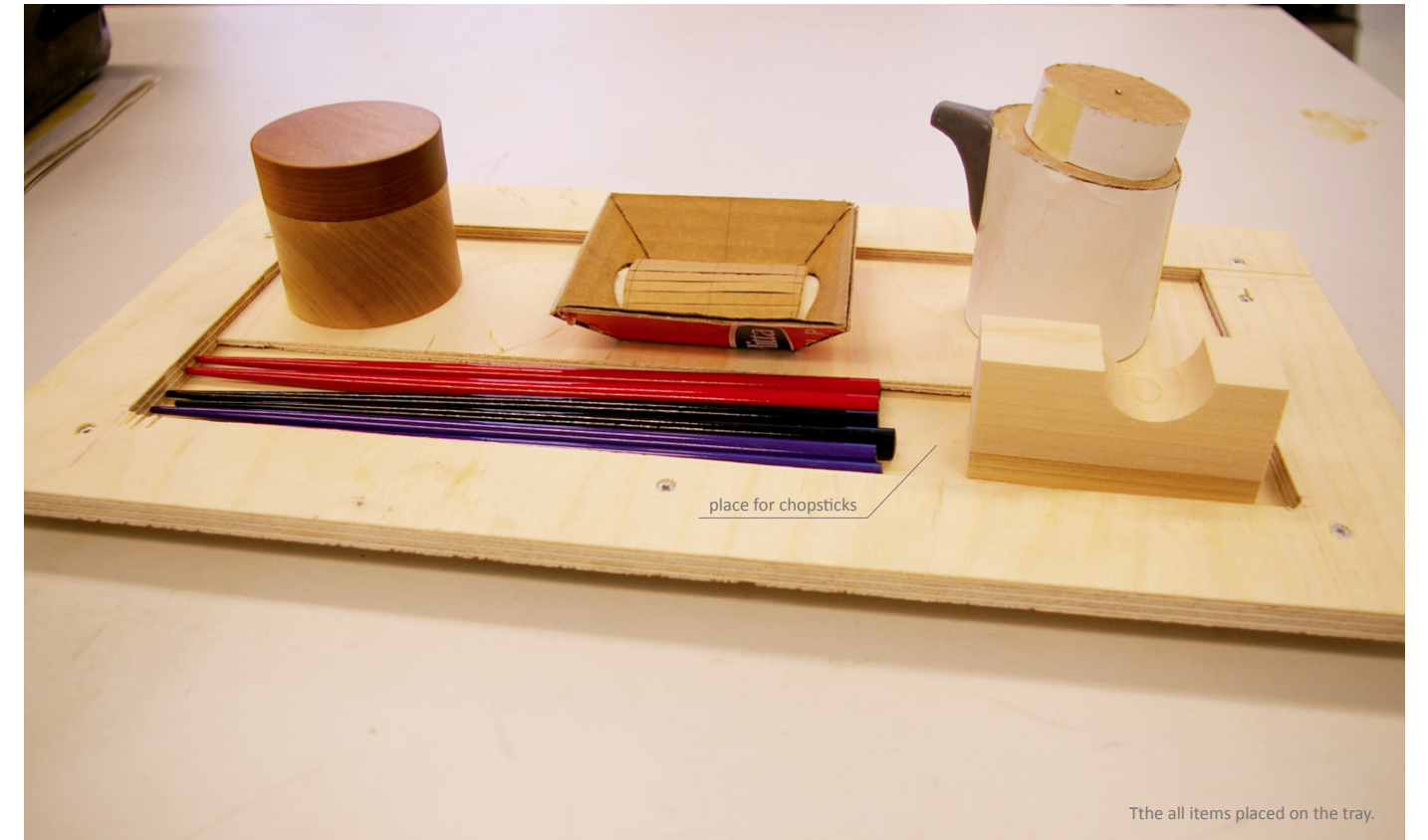

Next, I thought I should place all the items together as I was thinking of a place for the chopsticks. These roll easily on a tray, when the tray is moved. Therefore I wanted a place for the chopsticks on the tray. I laid the models of the all items at that time on a tray.

TRAY

IDEAS - STEP 2 -

material : wood

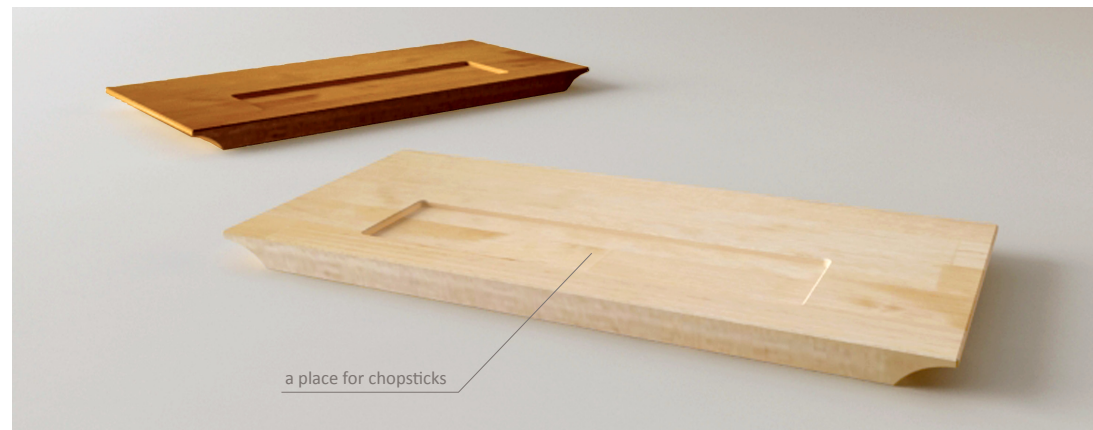
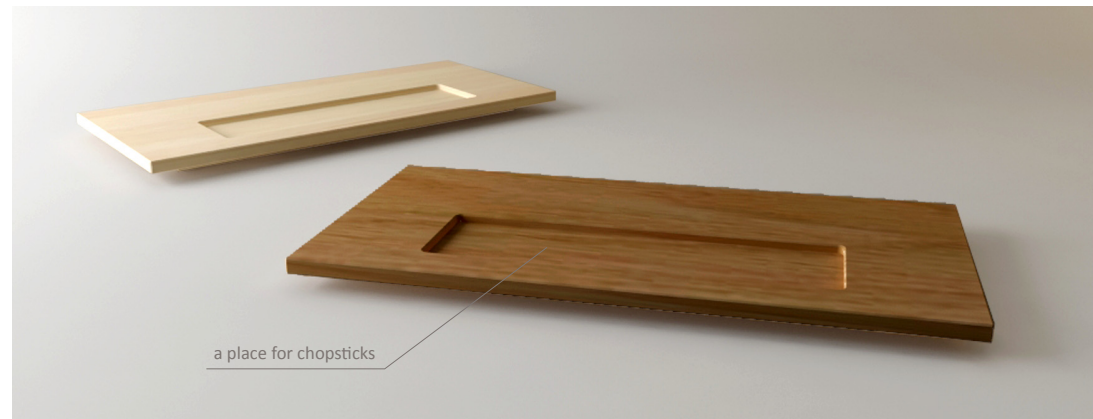

The new idea was a flat surface - a place for the chopsticks. This idea is clearer and more functional than before.

TRAY

IDEAS - STEP 3 -

material : wood

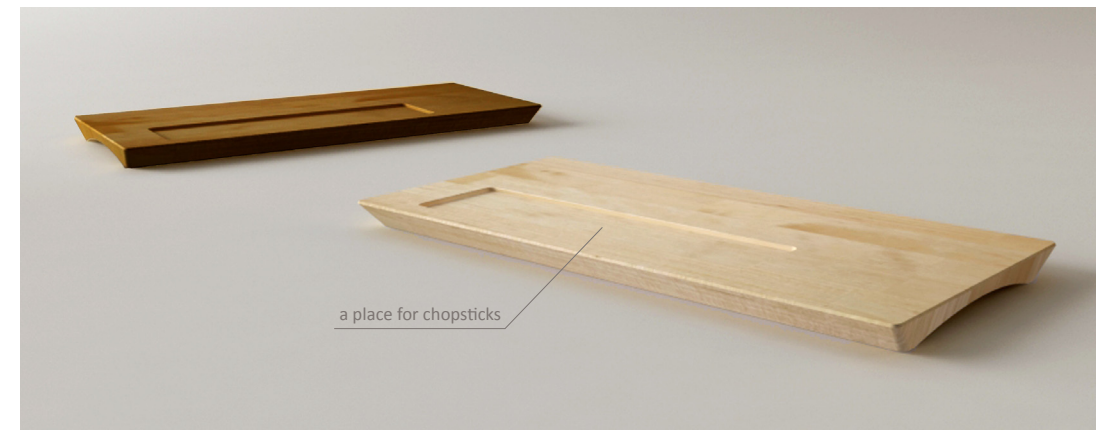
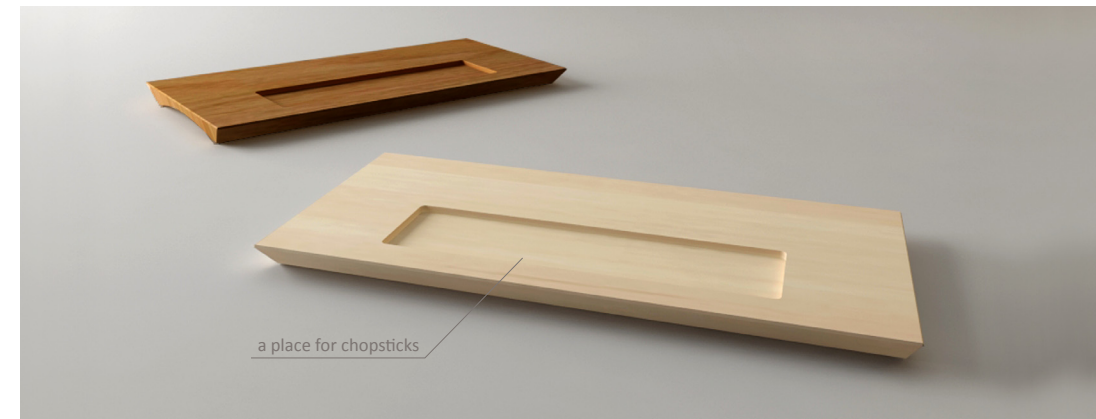

Variations for the place for chopsticks.

I was still thinking about the place for the chopsticks.

The form came from the mini plate which I designed for this project. The form made it easier to take hold of the tray. It also looks uniform with the other items of the series.

TRAY WITH ALL THE ITEMS

IDEA A

It seemed almost fine, but I felt there was something too much. Was it the profile, the items or what? Most importantly, all items should look uniform with the 'Small Present' series.



- TRAY
- MINI PLATE B X 4
- SOY SAUCE POT B
- TOOTHPICK HOLDER A
- CHOPSTICK REST

TRAY WITH ALL THE ITEMS

IDEA B

Although I preferred soy sauce pot B, soy sauce pot C, which had a cylinder shape, seemed to be more uniform with the 'Small Present' series. However, there was still something too much, I thought.



- TRAY
- MINI PLATE B X 4
- SOY SAUCE POT C
- TOOTHPICK HOLDER A
- CHOPSTICK REST
- CHOPSTICKS X 4

TRAY WITH ALL THE ITEMS

IDEA C

The upper surface of the tray was flattened so that the ditch to put the chopsticks on the tray looks extra. A stopper made of ceramic was also added so that the chopsticks do not roll.



- TRAY
- MINI PLATE B X 4
- SOY SAUCE POT C
- TOOTHPICK HOLDER A
- CHOPSTICK REST
- CHOPSTICKS X 4

TRAY WITH ALL THE ITEMS

THE FIRST SAMPLES

TEST



I asked some of my Finnish friends about the items, their sizes, color and so on. My idea was to get opinions from people who did not know about sushi so much. I was happy to receive some good ideas from them.



TRAY WITH ALL THE ITEMS

IDEA D



Here are two types of the set.
The difference between them is the mini plate, that has been placed in the sets.
Earlier from IDEA A to C, I was thinking that the mini plate B is more suitable for my project. However, when I placed both types in the sets in IDEA D, it looked better with mini plate A than B. I noticed mini plate A would make a good contrast with the other items and recognized that it is, however, more suitable for the set.

TRAY WITH ALL THE ITEMS

IDEA D



The set was almost ready.
Still, I had forgotten something -the serving plate for sushi.

- TRAY (440 X 260MM)
- MINI PLATE X 4
- SOY SAUCE POT C
- CHOPSTICK REST
- CHOPSTICKS X 4
- +
- SUSHI PLATE X 1 OR 2

TRAY

IDEA -STEP4-

material : wood



TRAY WITH ALL THE ITEMS

IDEA D



SUSHI TABLE

EXAMPLES OF A SUSHI TABLE

TEST

For the sushi table with the items.



My idea of the sushi plate (serving plate for sushi) was to have two plates in the set. I thought that two plates would be enough for four persons. For example, one plate could be for vegetable sushi and the other one for seafood sushi, one plate for *MAKIZUSHI*(rolled sushi) and the other plate for *NIGIRIZUSHI*, and so on.

In my opinion it is better, if people share the sushi serving plates at the table. When doing so, they will also share the enjoyment of having a sushi meal together.

SUSHI PLATE

IDEA

material : wood



TRAY WITH ALL THE ITEMS

IDEAS



TRAY WITH ALL THE ITEMS

IDEAS



- TRAY
- MINI PLATE A X 4
- SOY SAUCE POT C
- CHOPSTICK REST
- CHOPSTICKS X 4
- SUSHI TRAY X 2 + ?

SUSHI PLATE

SAMPLES

TEST

Examples of situations at a sushi table with the sushi plate.



SUSHI PLATE

SAMPLES

TEST

Examples of situations at a sushi table with the sushi plate.

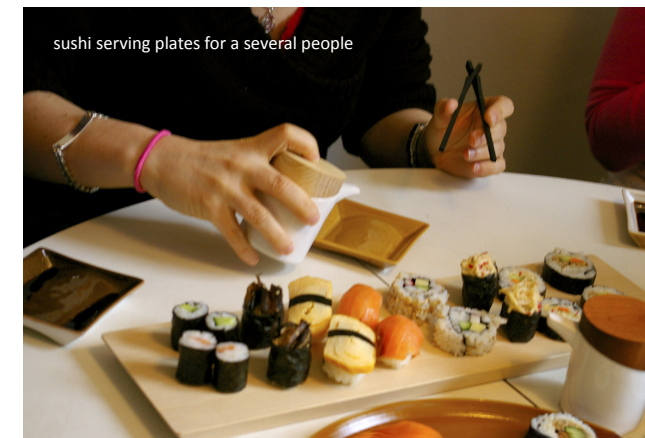

My first idea was not to have one sushi plate for one person. But when the amount of sushi ment for one person was placed on the serving plate, it was almost full. It seemed that there was not enough space to put more sushi on the serving plate. But when the sushi was arranged more freely on the serving plate, it was possible to add more sushi.

ITEMS

ALL THE ITEMS -FIRST SAMPLES- TEST

After eating, the dishes are removed from the table.



The sushi plates were easy to remove from the table since they can be piled on top of each other.

After placing the sushi plates on the tray, it is possible to put the other items on the plates. Cleaning the table is fast and easy this way.



ITEMS

ALL THE ITEMS -FIRST SAMPLES- TEST

For washing the items.



In Japan, Tableware is usually not washed with a dish brush. In Finland, however, it is a very common washing tool for tableware.

MINI PLATE:
It could be washed by a dish brush.

SOY SAUCE POT:
The outside of the soy sauce pot could be washed with the dish brush, but not the inside of the pot. It must only be rinsed off. In my opinion this is no problem.

SUSHI PLATE:
It could be washed with a dish brush.

TRAY:
I think it is not necessary to wash the tray every time, after use. It is enough to wipe it with a cloth.

Naturally, all the ceramic parts are also dishwasher-proof.

ITEMS

ALL THE ITEMS -FIRST SAMPLES-
TEST

For drying the items.



In Finland, people have a rack which is used for drying tableware, called 'kuivausteline'. It is placed on top of the sink inside a cupboard in every kitchen.

MINI PLATE and SOY SAUCE POT :
See page 62.

SUSHI PLATE:
It could be dried in the rack.

TRAY:
It can be put back where it was, if it was not washed.

ITEMS

ALL THE ITEMS -FIRST SAMPLES-
TEST

For storage in the kitchen.



The items can be kept in a standard-size cupboard in the kitchen. The idea was to place the soy sauce pot, the mini plate and the chopsticks on the tray, on the two the sushi plates. It is, therefore, easy to take the set out from the cupboard to the table.

THE FINAL PRODUCTS

THE FINAL PRODUCTS

ITEMS

- CHOPSTICK REST (wooden) _ exists already _

- CHOPSTICKS (wooden) _ design _

- mini PLATE (ceramic) _ design and prototype _

- SOY SAUCE POT (ceramic + wood) _ design and prototype _

- TRAY (wooden) _ design and prototype _

- sushi PLATE (wooden) _ design and prototype _

THE FINAL PRODUCT - ITEMS -

CHOPSTICKS

material : ceramic, wood



THE FINAL PRODUCT -ITEMS-

MINI PLATE
material : ceramic



THE FINAL PRODUCT -ITEMS-

SOY SAUCE POT
material : ceramic, wood (Finnish white birch, heat-modified birch)



THE FINAL PRODUCT - ITEMS -

SUSHI PLATE

material : wood (Finnish white birch, heat-modified birch)



THE FINAL PRODUCT - ITEMS -

TRAY

material : wood (Finnish white birch, heat-modified birch)



THE FINAL PRODUCTS -SET-

SMALL PRESENT

- MINI PLATE X 4
- SOY SAUCE POT C
- CHOPSTICK REST
- TRAY
- SUSHI PLATE X 2+?
- CHOPSTICKS X 4



THE FINAL PRODUCT -ITEMS-

USAGE OF THE ITEMS

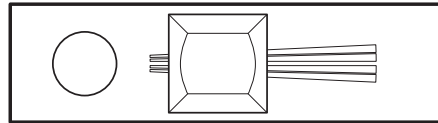
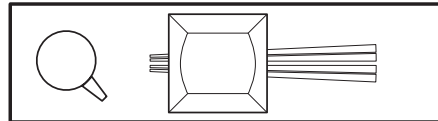
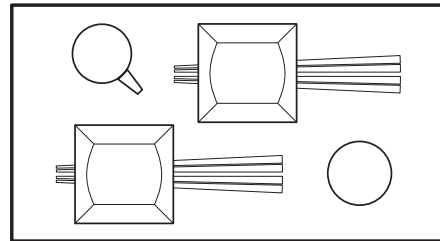

The sushi plate for the sushi, the tray for the tableware.

The tray for the sushi, the sushi plate for the tableware.

The tray for the sushi, a sushi plate for sauce, wasabi and so on, one plate for one person with a mini plate.

For a pair or a person. (Each one has a plate.)

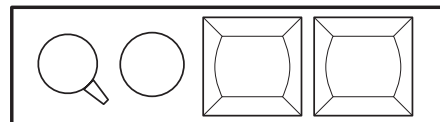

FINAL PRODUCT -ITEMS-

USAGE OF THE ITEMS



Here are some examples of how the items can be used for a sushi meal. There are no rules. The most important thing is to "Enjoy one's meal time!"

FINAL PRODUCT -ITEMS-

USAGE OF THE ITEMS



The items can also be used for a Finnish meal or for other purposes, such as a sandwich (voileipä) with milk for breakfast, Finnish buns (pulla) with a cup of coffee or tea for coffee break (kahvitauko), pies, cookies, cheese and so on.

FINAL PRODUCT -ITEMS-

USAGE OF THE ITEMS

The items can be combined in different ways.

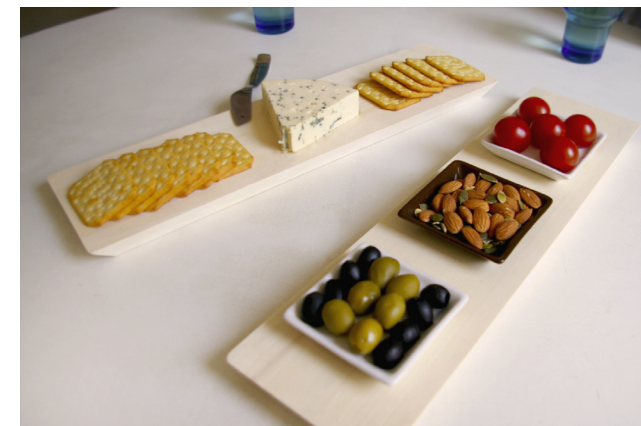





EVALUATION

THE PRODUCT

When I started the project, I was hard to imagine how the final products would look like. However, by the time I am writing this part, every part is finished.

The prototypes ended up working well and all the items of my project suit well with the 'Small Present' series, which was one of my main aims of this project. Yet, the functionality of some of the items has to be developed further, for example, the dripping nozzle of the soy sauce pot.

I hope that, the whole series will be more developed in the future, perhaps with some new additional color options and new products. New items could be developed for a Japanese green tea set, a Sake set or for salt and pepper.

My next aim is to find a manufacturer for the items. I hope my items will find their way to stores.

EVALUATION

PROCESS

This project has given me a lot of knowledge new challenges.

Since I started this project, I always tried to take pictures about every phase of the process. It helped me a lot, when I explained the project while making this book. But it was also difficult to take the pictures by myself at the workshops of ceramic and wood. Especially when I did the color glaze for the ceramic parts.

Usually, I do not draw a lot when I design. It is easier for me to think by three-dimensional models, such as a cardboard model, a clay model and so on. In this project, I also use this method a lot. Because I had started the process earlier, then I could imagine the basic shapes of items. I think making three-dimensional models was a good way to think about small products, such as these tableware products.

Wood is a very familiar material to me, so it is easy for me to make prototypes of it, as long as any special techniques are not required. I enjoyed making the prototypes.

I have tested the usage of the items several times with European and also with Japanese people. This gave me a lot of useful and interesting information.

It was very challenging for me to do the written part of the project as well as the layout of the book. However, I tried to make the book quite simple, so it could be easy to understand by people who are not familiar with the project.

I have finally managed to finish the project, which, in the end, makes me feel proud of my work and my self.

SOURCES AND PHOTOS

ELECTRONIC MATERIALS

- <http://www.aarikka.fi> (26.1.2009)
<http://www.iittala.fi> (26.1.2009)
<http://www.marimekko.fi> (26.1.2009)
<http://www.artek.fi> (26.1.2009)
<http://www.sectodesign.fi> (26.1.2009)
<http://www.designforum.fi> (26.1.2009)
<http://www.tonfisk-design.fi> (26.1.2009)
<http://www.mintnyc.com> (26.1.2009)
<http://www.welcome-ina.com/archives/48> (26.1.2009)
<http://www.monsen.jp> (26.1.2009)
<http://boo-hoo-woo.com> (26.1.2009)
http://http://www.koizumi-studio.jp/html_works/03_3h_9.html (26.1.2009)
http://www.iconicinteriors.com/our_products/category/chairs/the_barcelona_chair
 (26.1.2009)
<http://www.trendir.com/interiors/bathroom-decorating-with-gsc-c.html> (26.1.2009)
<http://www.alessi.com> (16.1.2009)
<http://en.wikipedia.org/wiki/Sushi> (30.1.2009)
<http://www.japan-guide.com/e/e2038.html> (30.1.2009)
http://en.wikipedia.org/wiki/Soy_sauce (30.1.2009)
http://en.wikipedia.org/wiki/Cuisine_of_Finland (8.2.2009)
http://en.wikipedia.org/wiki/Japanese_cuisine (8.2.2009)
<http://www.arabia.fi/web/Arabiawww.nsf/en/home> (20.2.2009)
<http://www.kwintessential.co.uk/resources/global-etiquette/finland-country-profile.html>
 (20.2.2009)
<http://finland.fi/netcomm/news/showarticle.asp?intNWSAID=25001> (20.2.2009)
<http://www.finnishdesign.fi/designerbio?id=946518> (22.3.2009)
http://www.edu.fi/oppimateriaalit/esine_elaa/keramiikka/historia.html (22.3.2009)

PRINTED MATERIALS

- Mirja Orvola, 2000: Craft design Heikki Orvola, Kirjapaino Kaleva, Oulu
 Jenifer Hawkins Opie, 1989: Scandinavia Ceramics & Glass in the twentieth century, Arti Grafiche Motta S.p.A. Milan, Italy
 David Cowley, 1978: Molded and slip cast pottery and ceramics, B T Batsford, London ,UK

PICTORIAL MATERIALS

- All illustrations are made by Miwa Ishizuka.
 Pictures from 3-D modelling rendered with V-ray for Autodesk 3ds Max 2008.

PHOTO MATERIALS

- Page 41. and page 100.-105. photos taken by Antti Ahtiluoto.
 All other photos taken by Miwa Ishizuka.

SOURCES AND PHOTOS

Page 38. and 39.



1. Kikkoman Soy sauce table dispenser, Kenji Ekuan: Kikkoman
<http://jida-dm.syncline.jp/DMHP/2006/item13.html>
2. Hakusan 3-piece condiment set, Masahiro Mori: HAKUSAN
<http://www.monsen.jp>
3. G-type Soy Sauce Bottle, Masahiro Mori: HAKUSAN
<http://www.monsen.jp>
4. so ysauce pot (marumon), Sori Yanagi
http://boo-hoo-woo.com/online-shop/table/wa/yanagi_s11_1
5. pozzo, Shotaro Shibata: Miyama
<http://jida-dm.syncline.jp/DMHP/2006/item13.html>
6. <http://p-life.ciao.jp/item95834.html>
7. http://www.igc.co.jp/page/mp/mp_1_tyoumiryou.html
8. <http://www.ebisuyatsugarunuri.net/product/122>
9. Lovorika Banovic: menu
<http://item.rakuten.co.jp/belle-life/4722929>
10. <http://www.rakuten.co.jp/shokki/522500/534050>
11. IKEA Japan
<http://www.ikea.com/jp/ja/catalog/products/5011365>
12. Hakusan
http://www.rakuten.co.jp/angers/518997/553792/553793_5

13. G-type soy sauce bottle Masahiro Mori: HAKUSAN
<http://air-plus.jp/origin/hakusan>
14. MUJI
<http://www.muji.net/store/cmdty/detail/4547315873944>
15. http://www.matsuhisa-japan.com/shop/index_en.html
16. TALKING, nendo
http://boo-hoo-woo.com/online-shop/table/other/nendo_03/index.html
17. Lily Bird soy sauce container, Giovanni Stefano: ALESSI
<http://www.alessi.com/en>
18. <http://www.aritaware.com/shopping/>
19. <http://shoindo.com/?pid=9928156>
20. <http://www.utsuwaya.com/page/binsai/sirutugi.html>
21. <http://utsuwashop-bbp.com/artists/kuwawork.htm>
22. <http://living.commoplus.com/artist/090217112051.html>
23. Sori Yanagi
<http://designshop.jp-stores.com/>
24. <http://item.rakuten.co.jp/yuyuyu/10000172/> <http://designshop.jp-stores.com/goods>
25. http://www.geocities.jp/motitae/usagi/new_page_6.htm



Elina Rantapuska, Pasi Pänkäläinen, Vesa Damski, Kimmo Kukkonen, Tuija Marila,
Lilli, Jonna, Antti ja kaverit

ATTACHMENTS

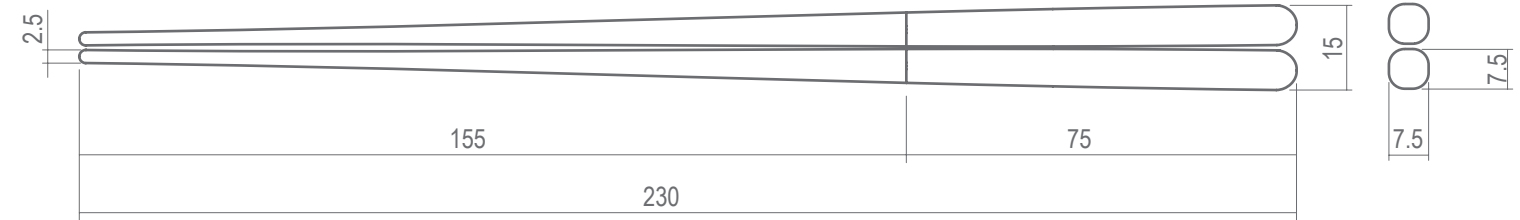

item	chopsticks	scale	1 : 1	unit	mm
materials	wood	22.04.2009, Miwa Ishizuka			

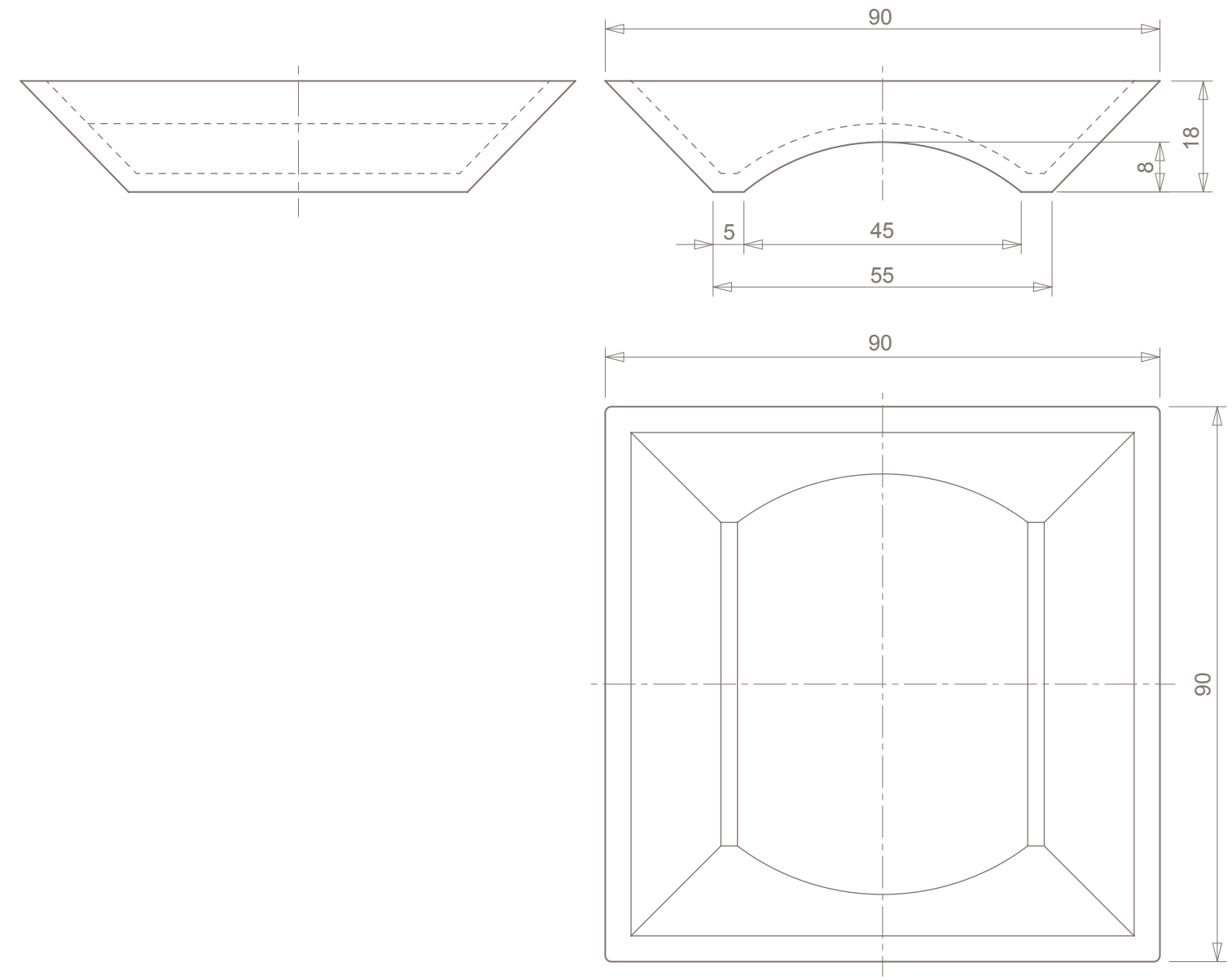

item	mini plate	scale	1 : 1	unit	mm
materials	ceramic	22.04.2009, Miwa Ishizuka			

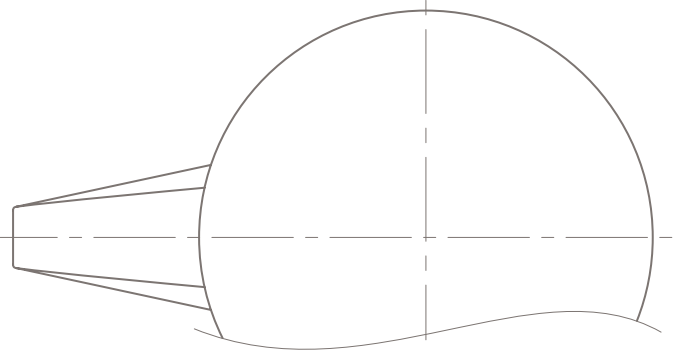
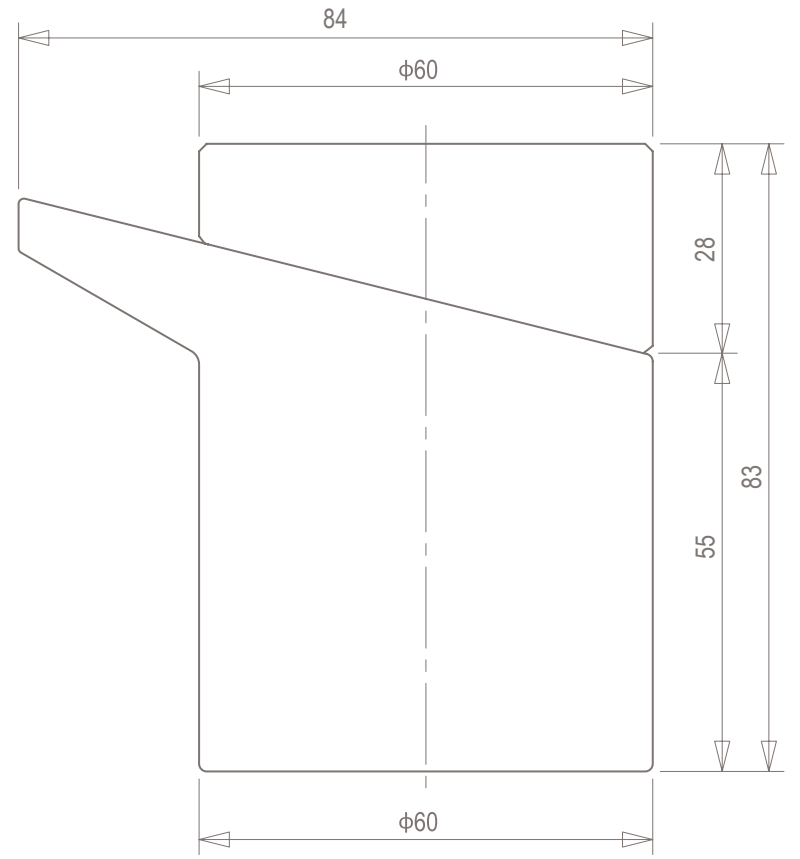
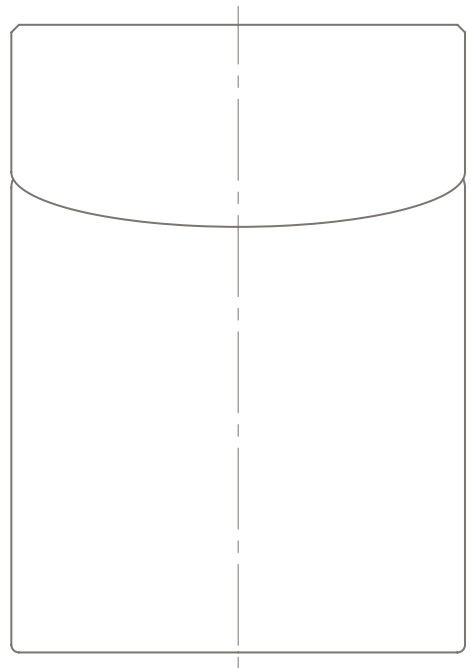

item	soy sauce pot	scale	1 : 1	unit	mm
materials	ceramic, wood	22.04.2009, Miwa Ishizuka			

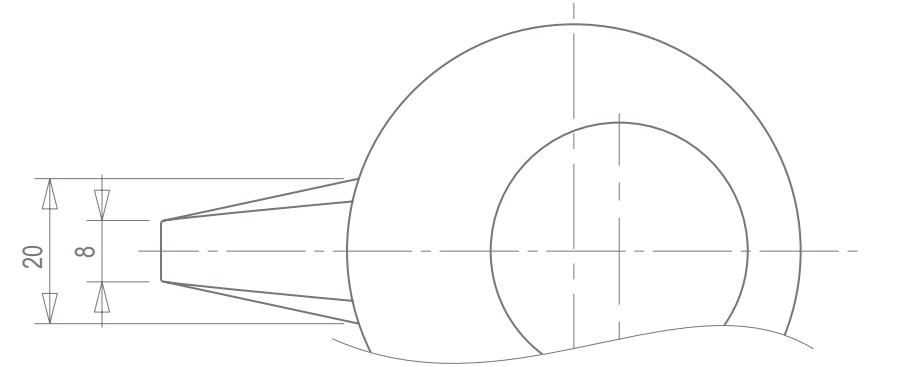
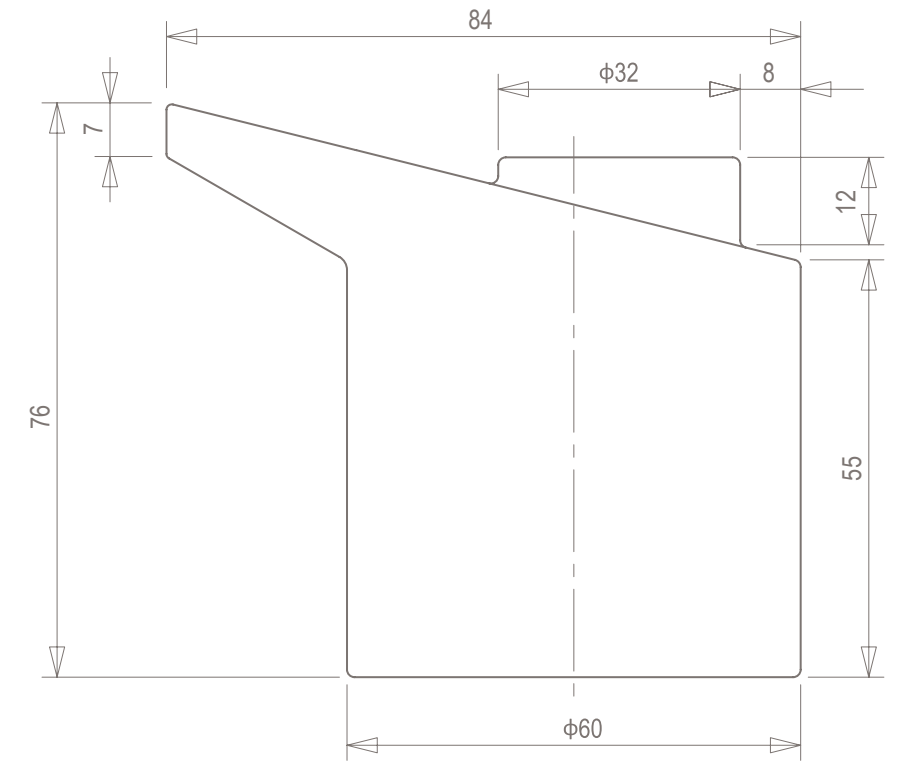
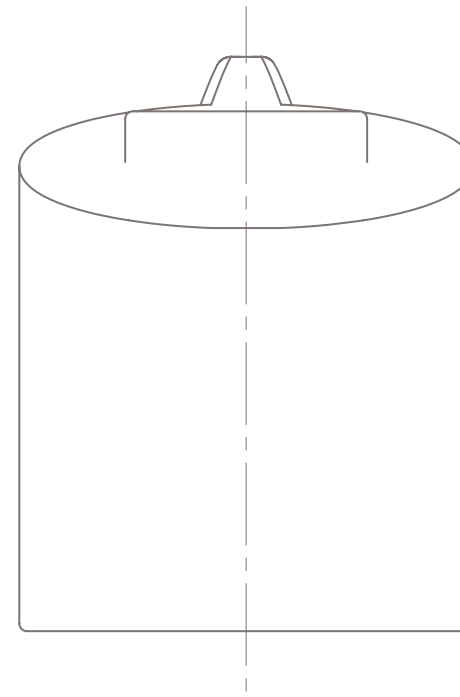

item	soy sauce pot (body)	scale	1 : 1	unit	mm
materials	ceramic	22.04.2009, Miwa Ishizuka			

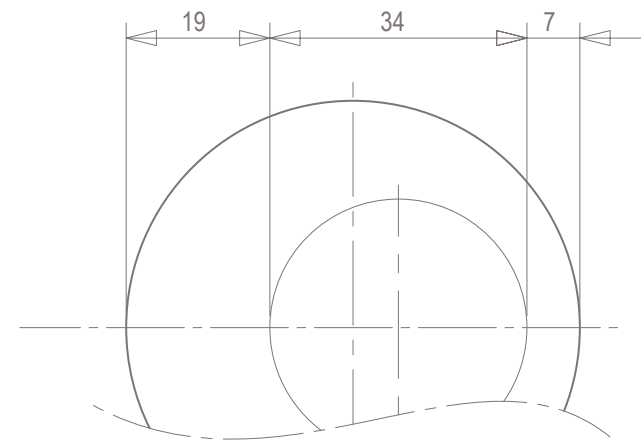
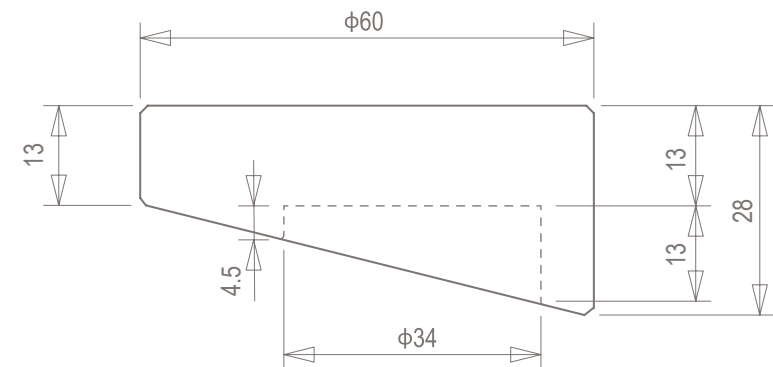
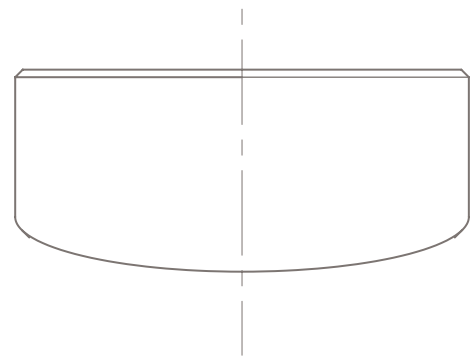

item	soy sauce pot (cap)	scale	1 : 1	unit	mm
materials	wood (birch)	22.04.2009, Miwa Ishizuka			

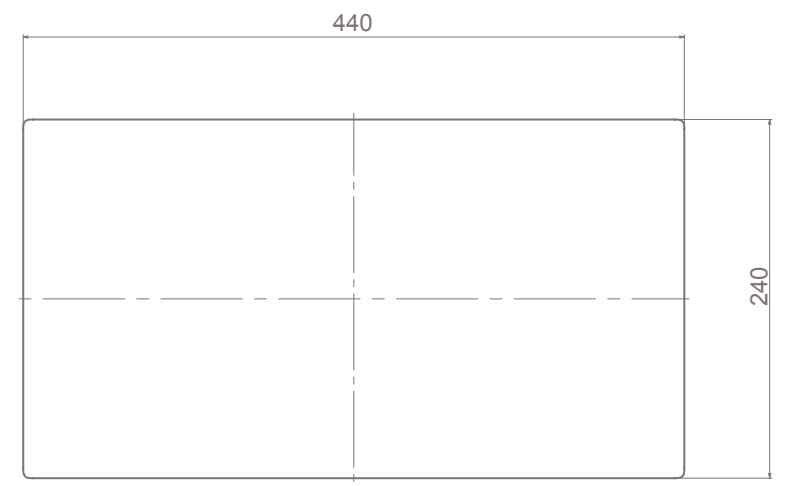
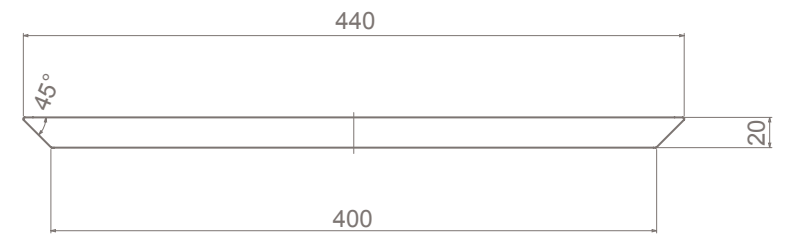
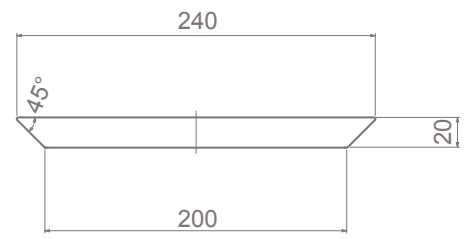

item	tray	scale	1 : 5	unit	mm
materials	wood (birch)	22.04.2009, Miwa Ishizuka			

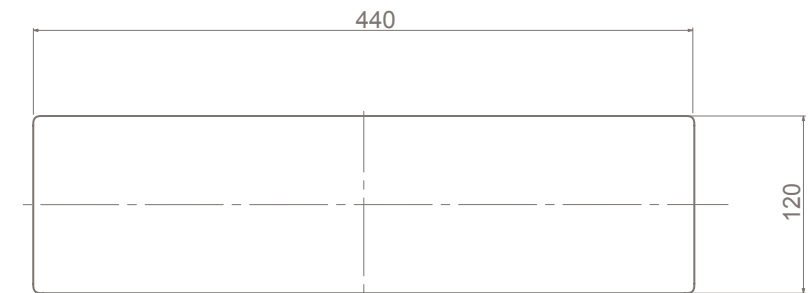
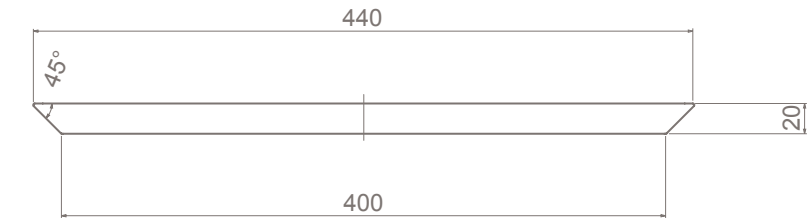
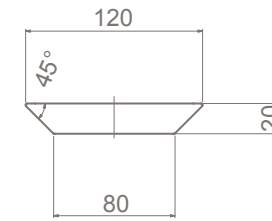

item	sushi plate	scale	1 : 5	unit	mm
materials	wood (birch)	22.04.2009, Miwa Ishizuka			

ITEMS FOR THE SMALL PRESENT SERIES

MIWA ISHIZUKA
2009