



SEINÄJOEN AMMATTIKORKEAKOULU  
SEINÄJOKI UNIVERSITY OF APPLIED SCIENCES

**This is an electronic reprint of  
the publication (publisher's pdf).**

Please cite the original publication:

Knuuti, K. (toim.) 2020. Media guide : Media literacy for adults. Helsinki :  
Kansanvalistusseura. [http://mediaguide.fi/mediaguide/wp-content/  
uploads/2020/08/KVS\\_media\\_guide\\_web\\_2020.pdf](http://mediaguide.fi/mediaguide/wp-content/uploads/2020/08/KVS_media_guide_web_2020.pdf)



# MEDIA GUIDE

Media Literacy for Adults

# MEDIA GUIDE

Editor: Karoliina Knuuti

Editor: Karoliina Knuuti

Working group: Emad Alasfr, Akram Al-Jariri, Viivi Itkonen, Petri Kangas, Elisa Kannasto, Ville Koivisto, Terhi Kouvo, Aapo Laakso, Saleh Masharqeh, Yasmine Misk, Tuuli Oikarinen, Anne Tastula, Anna Tervahartiala, and Nibal Thawabteh.

English proofreading: Kielipalvelu Kauriin Kääntöpiiri Oy

Translation from Finnish to English: Osku Haapasaari

Translation Arabic-English-Arabic: Ritaj Managerial Solutions (RITAJ)

Images: Aura Vuorenrinne, Markus Viljasalo

Layout design: Oy Graaf Ab

Publishers: Kansanvalistusseura sr. (The Finnish Lifelong Learning Foundation) and Media Development Center of Birzeit University

© 2020 Kansanvalistusseura sr. (The Finnish Lifelong Learning Foundation) and Media Development Center of Birzeit University. This work is licensed under the Creative Commons CC BY-NC-ND 4.0 Licence. To view a copy of the licence, visit [creativecommons.org](https://creativecommons.org).

ISBN 978-951-9140-74-2 Media Guide

ISBN 978-951-9140-75-9 Media Guide (web)

This publication has been produced with the support of the Finnish Ministry for Foreign Affairs in Finland. The Ministry support does not constitute an endorsement of the contents which reflects the views only the authors, and the Ministry cannot be held responsible for any use which may be made of the information contained therein.



# CONTENTS

Foreword .....	6
<b>1 What is journalism?</b> .....	<b>9</b>
Journalism as a societal profession .....	11
How is journalism conducted? .....	12
Journalism genres and article types .....	14
News criteria dictate what we hear about in the news .....	15
The process of making a journalistic article .....	16
The characteristics of TV and radio journalism .....	17
Data journalism and infographics first-class services for readers .....	18
<b>2 Critical reading of journalism</b> .....	<b>20</b>
The choice of topics affects our way of thinking .....	21
Article format crams the world into a pre-shaped mould .....	22
Lies, damn lies and statistics .....	23
Media and science have much in common – and many differences .....	24
Discrimination, stereotyping and picking experts .....	25
<b>3 The ethics and self-regulation of journalism</b> .....	<b>29</b>
Ethical principles of journalism .....	30
The self-regulation of journalism .....	30
Journalistic guidelines share similarities globally .....	32
Guidelines for acquiring information, publishing and correcting information .....	33
Guidelines for the professional position of a journalist .....	36
Guidelines for the rights of an interviewer and interviewee .....	38
Guidelines for private and public .....	40
Guidelines for protection of sources .....	41

<b>4</b>	<b>What is visual journalism?</b>	<b>45</b>
	The basics of photojournalism	45
	Genres of photojournalism – spot news, illustration and feature photography	46
	Photojournalist or photographer?	47
	Shot sizes and composition of a photograph	48
	How far can your camera see?	51
	Meeting a subject of photography	51
	The basics of video expression	53
	The basics of editing	55
	Audio narration as a part of video expression	57
	Graphic design and illustration	58
<b>5</b>	<b>Critical reading of visual journalism</b>	<b>59</b>
	The rights and responsibilities of a photographer	59
	Probative value and photographic cogency	60
	The ethical guidelines of photojournalism – how to retouch ethically	61
	Critical reading of visual content	62
<b>6</b>	<b>The digital revolution and social media</b>	<b>64</b>
	Social media platforms and tools	66
	Social media challenging traditional media	67
	Revenue logic of social media	71
	Activism and campaigning on social media	73
	How to use social media as a business or a community?	74

<b>7</b>	<b>Critical reading of social media</b> .....	<b>76</b>
	Online conversations tend to be polarised .....	76
	What is allowed in netiquette? .....	77
	Fake news sites flourish on the dark side of the internet .....	79
	Content verification can help in tackling the problem of fake news .....	80
<b>8</b>	<b>Understanding media advocacy</b> .....	<b>84</b>
	Differences between public relations officers and journalists .....	84
	Lobbying is convincing with arguments .....	86
	Marketing communications .....	86
	Critical reading and good practice of marketing .....	90
<b>9</b>	<b>Introduction to human rights</b> .....	<b>93</b>
	Most important human rights documents and agreements .....	94
	Three generations of human rights .....	94
	Human rights dilemmas .....	97
	The role of the media in human rights .....	98
	Freedom of speech is the foundation of journalistic work .....	99
	Censorship and violations of freedom of speech .....	100
	Discrimination, equality and the work of journalists .....	103
	<b>Bibliography</b> .....	<b>106</b>

# FOREWORD

**W**hat is the role of journalism in democracy? What should every citizen understand about the basic functions of the media and human rights? How to be an ethical professional or citizen journalist? How to read and analyse media content critically?

This textbook, *Media Guide – Media Literacy for Adults* is the second and fully revised edition of the textbook of the same title, published in April 2016. The fundamental aim of the second edition is the same as in the previous one: to give at least some answers to the questions above. But as the media sphere is in a constant state of flux, answering them fully in a textbook like this, even when revising it every four years, is of course impossible.

To give an example, since 2016 many things have changed in the global media sphere. Politically speaking, Donald Trump, notorious for his blatant hatred of the press, has been elected the president of the United States, or as some call it – the “leader of the free world”. In Turkey, Recep Tayy-

ip Erdoğan has taken leaps in converting the country into a totalitarian state with no media freedom. Also, elsewhere in Europe and beyond, populist and far-right movements, many of which challenge the basic institutions of democracy, are gaining more support. These examples are just the tip of the iceberg, as similar trends and phenomena threatening press freedom and people’s right to information can be found in many countries around the globe.

On the other hand, to name some more positive changes, ‘Islamic State’ or ‘Isis’ whose use of social media in propaganda was handled in the previous edition has been largely defeated. Another interesting positive trend is that, while many media corporations still struggle to balance their revenue in the digital era, a few very aspiring citizens’ journalism groups have managed to establish themselves in the field of responsible journalism. Perhaps the most prestigious of these is the international network of investigative journalism called Bellingcat, first established in 2012, which, among other things, has played an important role in



uncovering human rights violations during the Syrian war.

Despite all these changes, many of the basic starting points of the book still remain the same. In 2020, the media sector is still looking for new ways to cope with digitalisation. Also, the pace of development of new media technologies keeps accelerating. The urgent need for ethical and responsible journalism, especially in fragile or conflict areas, has not lost its importance, indeed quite the opposite.

In fact, more people are using the internet now than ever in history. According to Statista, in January 2020 the percentage was already 59 %, amounting 4.5 billion people. The number had more than doubled in the last decade. People all around the world are spending more and more of their daily time on digital media, posting, blogging, sharing, liking and even starting their own online newspapers. These figures also suggest that every year there are millions of new internet and social media users who might not have any knowledge of ethical guidelines and never have heard any worrisome talk of social

media changing our public discourse. We are nowhere near the saturation point for the need of media literacy training.

All the aforementioned trends raise a few important questions. What does the future of journalism look like? How may the professionals “prove” that they are needed when there is always an inexhaustible, increasing number of amateur commentators and photographers present? How to ensure that the global expansion of media technologies will support freedom of expression and lead to diversity and pluralism and not the opposite? When encouraging citizens’ journalism, how to ensure that they will spend their time and effort sifting through the facts from the rumours and sharing accurate information instead of encouraging propaganda?

**This textbook** is a package of basic knowledge about journalism and media literacy. It is concerned with the working practices, ethics, work-related rights, freedom of speech and the power and responsibility related to the profession of journalism. The guide has been designed to benefit both professional

journalists and citizen journalist, as well as anyone who is interested in learning how the media works.

However, since the context of the publication is a media literacy education project in Palestine (*Media Literacy for Sustainable Society 2019–2020*) that was funded by the Ministry for Foreign Affairs of Finland, there is a slight overrepresentation of examples from Finland, Europe and Palestine. However, much of what is discussed such as ethical guidelines and human rights are based on globally agreed principles, and if one was to find a country of reference, Finland, a country that has stayed in the top 4 in the RFS press freedom index ranking for as long as the ranking has existed, is not the worst choice.

On the other hand, Palestine as an occupied territory is an interesting example of the many ways that media coverage can either solve conflicts or totally fail to do so. The decades-long Israeli-Palestine conflict makes the work of Palestinian journalists in the area very challenging in many senses.

**The first three chapters** of this textbook introduce the reader to the basic principles and guidelines of journalism and critical media analysis. Chapters 4 and 5 handle visual and audio-visual journalism and critical reading of visual content and video editing. Chapters 6, 7 and 8 introduce the reader to social media and media advocacy and offer tools for their critical reading. The last chapter, 9, is about human rights.

All chapters include general knowledge that will help people to learn about profes-

sional journalistic work processes, how to improve their professionalism and also how to read media content as a citizen in a critical and analytical way. There are also four types of information boxes that deepen the topics, give additional information and activate the reader.

The ‘food for thought’ boxes offer examples that activate the reader and support self-study. They also contain questions that teachers can use as tasks or topics for classroom debates.

The ‘pro tips’ are aimed at journalism students or professionals. They offer a set of concrete guidelines and tips that may be helpful professionally.

The ‘summaries’ boxes deepen the topic being examined and offer study material for advanced students.

The ‘glossary’ boxes provide vocabulary and terminology related to the topic under discussion.

**As journalism exercises** significant social power, my view is that *everyone* should have at least a basic idea about the principles of journalism and the ethical guidelines that should guide the work, just as any citizen should be educated in the political system in their surroundings and to know their history. In other words, I see critical media literacy skills as part of active citizenship.

I hope this textbook will help the reader on their way.

Ramallah 11 February 2020

*Karoliina Knuuti*

# 1

# WHAT is JOURNALISM?

**M**ass communication is communication directed at a large group of people and relayed through a media channel. Journalism, public relations, advertising, marketing communications, art, entertainment and citizen communications are all parts of mass communication.

Journalism, on the other hand, can be defined as timely, fact-based communication that offers the audience edited content in a reliable and independent fashion. The style, focus and genre of journalism may vary, but the same basic principles apply.

Journalism is produced for several different media channels, including newspapers, magazines, radio, television, online magazines and, in some senses, documentary films. Branches of journalism are, for example, politics, economy, culture, entertainment and sports.

The most important function of journalism is to convey information. By doing this, journalism is an important part of the democratic decision-making system, as it brings transparency to society and makes sure that decisions that are made are in tune with people's sense of justice. To ensure the possibility for civil advocacy, it is important that citizens

are already informed of decisions when they are being prepared.

In other words, the journalists' mission is to oversee the work of government officials on behalf of the citizens. The press, or media in general, is occasionally called 'the watchdog of society' or the 'fourth estate'. 'Watchdog' refers to the fact that journalists are supposed to call policymakers to account for their actions. Based on the classical theory about the tripartite system formulated by French 18<sup>th</sup>-century political philosopher Montesquieu, the other estates of modern democracies are the branches of the legislature, executive and judiciary.

In 2010s, the work of professional journalists has been frequently scrutinised through different social media channels.

Journalism also acts as a two-way channel between the public and policymakers. On the one hand, it conveys information to the citizens about what is happening in society. On the other hand, journalism lets the policymakers know what kinds of effects their previous decisions have had and what kinds of decisions have been made elsewhere. Journalism also lets the policymakers know what the public expects of them.

In addition to conveying information, good journalism interprets the world. Journalism explains things and phenomena in an easy and accessible way, describes the cause-and-effect-relationships of events and provides background information on issues and decisions. Journalism brings events closer to people's everyday lives and shows what kind of impact they have on the lives of regular citizens. This can be said to be how journalism performs the above-mentioned tasks.

Journalism's functions also include the creation of a sense of solidarity in society, which can happen, for example, through

large newsworthy events. By establishing solidarity, journalism can be said to maintain peace in society.

In comparison to times before social media, as we enter the new decade of the 2020s, people's consumption of media is a lot less consistent or channel-loyal. Instead of subscribing to the number-one local newspaper or gathering the whole family to watch the national TV news every night, people tend to collect information from different sources. That is why ever larger news events are needed to affect people collectively. Assassinations, wars and acts of terrorism feel like turning points in history, largely because of their wide news coverage. Widely covered events become a part of history, and the audience following the events feel that they are experiencing a historical event. Nevertheless, it is good to remember that media has the power both to blow things out of proportion and to sweep



### The tasks of journalism

- To convey information
- To interpret the world
- To call decision-makers to account on behalf of the citizens
- To serve and assist communities
- To entertain
- To activate people
- To create a sense of solidarity in society

them under the rug. Today's news coverage is not an impartial summary of the truths of world events – it is put together by a group of media professionals based on news criteria such as geographical proximity and even based on personal interest.

Journalism also tries to whet people's appetite for learning new things. Journalism entertains, evokes emotion and experiences. It offers new perspectives and stories, which people can relate to.

## Journalism a societal profession

The profession of journalism is a public and social occupation. Journalists as professionals both support and sustain the credibility of the decision-making system and maintain its functions. Whether a journalist is actually a user of social power is, however, a more complicated question.

The work of journalists is essentially the same, irrespective of the media channel (radio, television, press or so on), as the same principles and values of news production and conveying information are still valid.

The most important values of a journalist are truthfulness, impartiality, independence of commercial and political interests and responsibility. Thus, even if a journalist handles social issues, s/he must not strive to be a political force. A reporter can present pointed opinions, but it has to be done separately from news work, otherwise the credibility of the reporter as an independent conveyor of information is undermined, and the audience can easily begin think that everything that the journalist in question does is biased.

Journalists must adhere to good journalistic practice, and this largely happens through self-regulation.

The societal position of a reporter is very acutely described by a textbook of Finnish journalism “Principles of Journalistic Work”, written by Aino Suhola, Seppo Turunen and Markku Varis (2005), which outlines the premises of press work (translated into English by Osku Haapasaari):

“You are a reporter, not a star. You are a servant of the people, not a ruler. You are a seeker of knowledge, not its guardian. You know people, but you are not everyone's friend. You are there, but not seen – you are a shadow. You are present, but you are not the object of the piece of news, nor the one something is happening to. You are not the protagonist of the news article. You do a profession which is mundane work. You are a professional, according to whose information the majority of us construct our worldview.”

Even though journalism is very important to the functions of a democratic society, journalism as a profession is sometimes not held in a high regard.

Many reasons can be found for this: prejudice and outcry related to gossip magazine reporters and the paparazzi, accusations of



**The core values of journalism**

- timeliness
- truthfulness
- impartiality
- independence
- representativeness
- responsibility

bias and of sucking up to policymakers have all affected people's attitudes towards journalists. Additionally, people easily criticise the work of a journalist if the perspectives or the coverage do not appeal to them for personal or ideological reasons.

## How is journalism conducted?

Journalism is teamwork conducted by a large group of professionals.

An editor-in-chief is in charge of the whole publication. They make the final decision on the views expressed in the publication. They are also responsible for the legality of the content of the newspaper or media, and for ensuring that the publication adheres to good journalistic practice. The editor-in-chief often writes the editorial, which shows the paper's outlook on a topical issue. In large papers, there might be multiple editors-in-chief, to the point where there can be a separate department for writing the editorials.

i

### Journalistic work process

- Coming up with idea
- Making an article plan including the story angle
- Gathering information and conducting interviews
- Compilation and modification
- Publication
- Gathering and discussing feedback



## Journalistic glossary

### Caption

A short passage written to accompany an image or a photograph, which comments on the picture. A caption often includes the photo credits.

### Citation

A direct quote of what the interviewee has said. Good journalistic practice dictates that what is said by the journalist and what has been said by someone else are clearly separated in the article or news item. For this reason, citations are often marked in a clearly discernible way, such as with citation marks.

### Commentary

A narration technique often used in documentaries and sportscasts, where a commentator outside the shot describes or provides background information to the viewer on the events happening on screen.

### Fact box

A summary is placed next to the article in the layout. It gives the basic information of the article, such as names and key figures, in an easily readable format.

### Headline

The title of the article that summarises the essential information from the article and grabs the reader's

attention. In an article, there can be multiple sub-headlines. Writing headlines is often done by the sub-editor.

### Introduction

The lead or core of the article, whose aim is to make the reader read the article to the end. The lead is usually the first one or two sentences of the text.

### Jingle

A short song melody used in radio and television advertisements, and also in the self-advertising of the radio and TV channels and programmes.

### News insert

A part shot or a shot recorded beforehand, which is featured in a television or radio programme.

### Podcast

A form of digital media, usually an audio file that is created in the form of a radio show, monologue or interview.

### Pull quote

A quoted passage from the text, which is enlarged and highlighted in the layout phase. Pull quotes make the body text lighter and more visually appealing. They can also be used to highlight the most interesting parts of the text.

### Pundits

or “talking heads” refer to the way TV production commonly visualises a topic by illustrating it with a close-up or a medium shot of the person speaking. Pundits can be, for example, experts, politicians, political analysts, spokespersons or journalists.

### Scoop

A significant piece of news, which includes new information about an important topic. A journalist or news organisation gets a scoop when it publishes an important piece of news before others.

### Sidebar article

A short article, which is a part of the handling of a larger topic. It is shorter than the main article, and provides some further information or a new perspective on the topic of the article.

### Voice-over

A production technique that superimposes a narrating voice over visual narration. Voice-overs are commonly used in news and film production.

A section- or line editor is usually responsible for a single sector of the media, which they organise and coordinate, for example technology or economics. A news/managing editor to a large extent decides what features get reported. A department manager/editor leads the work of a news department in large papers, such as the culture department.

A sub-editor and photo editor are titles in the middle management of the editorial office. A sub-editor is in charge of putting together and editing features, while a photo editor's responsibility is to order and pick visual content.

A layout designer uses layout software to create the layout for the printed paper. AD, the art director, is the staff member in charge of the visual appearance of the publication.

Reporters and photographers are employees of the editorial office who usually outnumber other kinds of employees there. Reporters come up with ideas for articles and produce articles and news stories, for which the photographers take and sometimes process the photos. A freelancer is a journalist who works outside the editorial office.

A multimedia journalist is a journalist who makes and modifies articles for the different channels of the same media. A multimedia journalist may, for example, write a dispatch for a piece of news, read it out loud for the radio and create an insert based on it for the television news.

A radio journalist creates journalistic audio content, such as news and interviews, for the radio. A radio presenter is a journalist who hosts radio shows. A radio presenter may, for example, conduct interviews and discuss news and current issues alone or with one or more colleagues. A radio presenter also introduces the edited content and songs played on the radio station. Likewise, a television presenter hosts television shows. Other public

figures besides journalists may also be used as television or radio presenters, including actors, models, comedians and experts.

A news anchor (newscaster, newsreader) is a journalist who appears on radio, television or online television. Some newscasters read news produced by the editorial staff with the aid of a teleprompter, a display device that enables the anchor to read the script while seemingly looking straight at the camera. Others appear in news programmes more in the role of a presenter, by discussing, interviewing and interpreting. This is the case in, for example, many US news channels, where the newscasters have a considerable amount of power as explainers of news and formers of public opinion.

## Journalism genres and article types

In journalism, there are several different article or journalism types. Some of the best-known include news articles, interviews, features, reviews, columns and editorials.

A news article is the most important article type in journalism. Its purpose is to convey information by answering the questions of what, where, when, how, why and who as neutrally and objectively as possible. The purpose of news is to tell people what has happened.

The form of a news article is highly standardised and regularly referred to as a downward-facing triangle structure. The most important information is located at the beginning of the news article and, from there onwards, less and less important background information is provided. The style has become so standard, that the last chapter or chapters of a news article can be removed during the layout without it hampering the ease of



understanding the article. The most important message in a news article is called a news lead. It is a brief, concise description of the article's content.

In its simplest form, an interview can be in a question-answer format, where both the reporter's questions and the interviewee's answers are quoted directly.

A feature article is a longer article type than a news article. A feature should be fact-based, objective and accurate, but the genre also allows for more creative expression than a news article. While containing elements of news, feature writing provides scope, depth, and interpretation of trends, events, topics or people. It aims to humanise, add colour, educate, entertain and illuminate. Types of features can be, for example, news features on a topical phenomenon including the use of several independent sources, profiles and reportages.

Columns, editorials and reviews are even more subjective article types than features. They can and usually do include openly personal opinions from the writer. Nevertheless, a good review not only presents the critic's opinions, but the critic's expertise is put into practice, for example to analyse a piece of art or culture and place it in a larger context or tradition. Likewise, a good column is not just a rant composed of the writer's thoughts but a well justified argument on a topical issue.

## News criteria dictate what we hear about in the news

Newsworthiness relates to different factors that influence whether a topic makes it to the news or not. Space in a print paper is limited in a concrete sense, but writing online news also uses up the working hours of reporters.



### Article types and genres

#### Article types of journalism include:

- News articles
- Features
- Portraits
- Reportages
- Interviews
- Editorials
- Columns
- Reviews
- Essays

#### Journalism genres include:

- News journalism
- Culture journalism
- Celebrity/people journalism
- Investigative journalism
- Gonzo journalism
- Citizen journalism

**Reflection:** Please come up with short descriptions of the concepts above. Can you name more article types or genres?

Factors that influence newsworthiness are the general news situation, media publicity, the varying needs of different media, target group thinking and follow-ups on a topic. In simple terms, the more dramatic an impact

it will have on the lives of a group of people, the more important a piece of news it is. Additionally, newsworthiness is always linked to a certain time and place. For example, the private lives of public figures are often only newsworthy when they are in contradiction to the public image created by those public figures, or to the values that they promote.

News criteria refer to the principles through which the newsworthiness of phenomena is assessed in editorial offices. News criteria include significance, expected level of interest, surprise factor, timeliness, geographical proximity, negativity and famous or influential persons.

In addition, in some cases, a certain news topic can become newsworthy just because it has been discussed in other media or it is trending in social media channels. When a piece of news has become a heated topic of discussion, other media want their share of the readers' expressed interest, and they start to echo and multiply the same news item.

i

### News values

- significance
- expected level of interest
- surprise factor
- forcefulness
- timeliness
- geographical proximity
- negativity
- famous or influential person
- potential for personification
- unambiguity, ease of definition

## The process of making a journalistic article

The work of a journalist begins with an idea, which has to be developed and formulated into a tight article plan - a work plan that defines the article's perspective or angle and has been clearly framed.

Effective information gathering is a part of a journalist's professional skills. Possible sources of information include perceptions and experiences of the journalists themselves and their acquaintances, officials, bulletins, news agencies, event notices, websites, forums, other media and rumours. The use of social media as a source of information has also increased during the 2010s. A journalist must take a critical stance on all information they receive, including that provided by officials. It is worth cross-checking any information from multiple sources, even if it has already been published. Additionally, it is necessary to consider whether, for example, an interviewee might have their own agenda in providing material for the article.

After the information has been gathered, it must be formulated into an article. Whether the medium is on paper, a website or, for example, the radio, journalists should strive for expression that is as clear and accessible as possible. It is good to avoid complicated concepts, lengthy sentences and foreign words. If, for example, an interviewee uses jargon related to their field, it is the journalist's task to either explain these terms in the text, or to ask the interviewee to translate their terminology into standard language. The journalist always has the right or even the obligation to ask "stupid questions".

After publication editorial offices should keep an eye on feedback, usually gathered straight from the website or social media

channels. People click, share and comment in the comments field located beneath the articles. In past times, feedback was primarily mailed to the office's post box or published as letters to the editor.

If an article contains errors, the editorial office must correct the error and/or publish a correction. If it can be argued that the article has offended someone, after its publication a right to reply can be granted to the object of the article.

## The characteristics of TV and radio journalism

The same principles of journalism are relevant no matter what news channel a journalist works for, but there are differences. One is that a good radio journalist is required to know recording and publication technology and needs to have clear vocal expression. A television journalist is also required to have a pleasing outward appearance.

In television work, the news value is determined by the visual aspect of the topic in addition to the news criteria related to press work. A common objective is that some footage from the location itself or some relevant illustrative footage is available, but often programmes have to resort to so-called talking heads or pundits.

However, there is no need to have footage on everything and everybody you talk of. The reporter may handle abstract topics by showing images of activities related to the topic while they narrate the information. Nevertheless, the tone of images and the language used should also be compatible with the topic, and the images must be carefully selected. For example, a picture of joyful workers does not match talk on a deteriorating economy.



### Tips for addressing audiences verbally on radio or tv

#### Voice and image

Support the story without adding ambiguity.

#### Text reading and pronunciation

Clear and organised.

#### Vocabulary and grammatical rules

Simple, correct and to-the-point.

#### Speed of reporting

Slow enough that the viewer can follow the news and understand it the first time.

#### Sound vibrations

Compatible with the content and meaningful. For example, a funeral cannot be a subject for any sarcastic tone.

---

Source: Paul Stanley, Center for Communication, University of Miami Professional Field Guide for TV News; published by the Media Development Center – Birzeit University.



## Tips for a TV reporter working in the field

- Before going into the field for live coverage, prepare some background information and go through the objectives with the anchor and photographer.
- When coverage goes on air, any new information should first be provided in brief then elaborated on and explained, if time allows. It is a good idea, for example, to provide a summary of all information that has been previously gathered.
- If a critical moment in the event appears, pause in talking and let the actions speak for themselves.
- Getting extremely close to the location of the event will not bring any special acclaim. The reporter is there as a transmitter of facts and not a TV star or a war hero. For the reliability of reporting, it is sufficient to know that a journalist is present at the location of the incident. Always remember that the security and safety of the work team comes first.
- At the scene, the same information is available to many people at the same time. A reporter can try to distinguish themselves from others by their choice of expressions and points of view.
- Not all confrontations are violent and not all rallies are massive, so things should be conveyed with reference to their actual magnitude. Avoid blowing things out of proportion.
- Reporting is teamwork. The praise and fame for successful reporting are not for the reporter only. A fair reporter gives credit to the whole team.

## Data journalism and infographics first-class services for readers

Data journalism is a journalistic work process during which large amounts of information are acquired, modified and analysed. It produces a “data journalistic article”, which often benefits from the publication of the data used for the article. Data journalism seeks to find interesting new perspectives and news by combining large amounts of content and analysing and combining them.

In addition to being the starting point for the writing of the article, data can be part of journalistic narration. Through visualisations, it is easy to present large amounts of

information to the reader in an understandable and interesting format. Data journalism can be presented through different infographics such as tables, percentage diagrams, maps, timelines or counters. Data can also be demonstrated in different creative ways like illustrations that represent dimensions.

Interaction with readers can also be utilised while producing data: readers can be asked to fill out a questionnaire, or the information they have entered can be collected and accumulated to form new data, which will be made available to readers once it is published.

Data journalism is often a very work-intensive method for journalists. Well-conducted data journalism is, however, a first-class

service for the reader. At its best, data journalism also serves different special groups, such as people with dyslexia or foreign-language readers.

Data journalism's different visual methods of expression are also very popular in social media, which favours the visual aspect and quick glances.

An example of presenting statistics visually.

## Religion of Palestinians

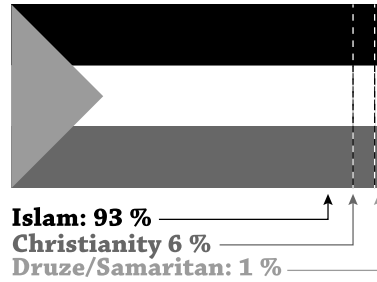

### Revenue logic of media

Revenue logic means a media corporation's way to create profits and thus to fund its functions. The revenue logic of media corporations has traditionally been based on dual markets: a newspaper or another journalistic product is sold to the consumers and the subscribing/paying audience is sold to the advertisers. This means convincing the advertisers of all the potential people who could see or hear the advert.

The digital revolution has had an impact on the revenue logic of media. Some advertising has moved to the websites of newspaper corporations. Online advertising is often more affordable than traditional newspaper advertising, which means that the total profits of newspaper corporations have fallen. Some corporations also use a bigger share of their advertising budget to market their products directly to their customers through their own websites and social media channels.

The self-evident downside of the digital revolution for media houses is that

people are less willing to pay for journalism, as all sorts of sources of information can be found online for free. The challenge of this trend is of course that not all free internet sources follow the same principles of truthfulness, impartiality and responsibility as the professional media channels do. The adverse consequences of this trend can then be witnessed in the popularity of some fake news, counter media sites and blatant propaganda channels.

Media companies are now trying to find ways to build new, digital-revenue models through which to maintain their trade. An example of these is the use of paywalls that restrict the access of users not logged in as subscribers to some or all of the content on a website.

**Reflection:** What do you think about the future of print media in light of the spread of electronic media? How do you think the revenue logic will be in ten years' time?

# 2

# CRITICAL READING of JOURNALISM

**T**he journalist's occupation is societal; it is a part of the construction of society. A journalist works with and within power relations that are part of all societies.

Nevertheless, the societal power of journalism may be difficult to perceive. The first step in becoming a critical reader of media is understanding that no article or

news piece is produced in a vacuum but in a network of societal and power structures and region-specific news values.

It is easy to notice that a columnist aims to convince the readership of their cause. What is harder to notice is that all forms of journalism are susceptible to bias. Even behind a news article or statistics whose form seems at first neutral and independent, there is always

a person, or an editorial office consisting of people, making choices. If the editorial office is honest and adheres to the ethical code of the profession, the article can be good and impartial. However, not even good intentions can guarantee an end result free of unintentional mistakes. The second step to the critical reading of journalism is to understand that the simple fact that an article has been published does not make it true.

## The choice of topics affects our way of thinking

*“It [the press] may not be successful much of the time in telling people what to think, but it is stunningly successful in telling its readers what to think about.”*

**Bernard Cohen, 1963**

It is rare for the media – if and when it covers the news neutrally and objectively – to be able directly to alter the opinion of people, even though it continuously influences what people are thinking about.

Agenda setting theory is a theory of influence which, in its simple form, states that media sustains themes or agendas that bind the audience’s interest. The media, according to the theory, uses societal power by bringing items to the public agenda.

One important concept related to this is coverage, the public space granted to a party by the media. An example of coverage would be an interview with an influential figure, writing a review on a restaurant or an art exhibition, or writing an article about a cause driven by a certain political party. Coverage can either be negative or positive in tone, but still be influential in making the audiences aware of



## Questions to help with critical reading of journalism

- Who has made the article/news story? Why has it been made?
- How has the article been made? What is its angle?
- Does the article include the writer’s opinions? Are they clearly separated from the facts?
- In what other ways could the same topic have been covered?
- At whom is the article targeted? What kind of reader does it seem to speak to?
- Whom does it represent? Who acts in the article? Who is presented as the object?
- Who gets to be presented as an expert? How is the expertise justified?
- What kind of facts are included in the article and what is left out?
- What kind of conclusions does the article encourage the reader to make?

**Reflection:** Can you come up with more questions?

something or someone. This phenomenon is strongly affected by the news values presented in the previous chapter. These values are somewhat the same in different media enterprises and even from country to country.

In addition, however, even though media in principle strive for impartiality, editorial offices also have their own agendas that influence what is highlighted in the mass media. Firstly, there are a great many media outlets that are specialised in something, say health issues, hobbies or foreign politics. Secondly behind every media there is an individual, usually the editor-in-chief, who has their own personal stance on societal issues. Thirdly, editorial office managers can have their own interests, or interests related to their position. Fourthly, reporting on a touchy issue may result in masses of feedback from the readers in general or a specific advocacy groups, and sometimes avoiding this kind of “trouble” may result in reluctance to cover certain topics. Fifthly, often the policy of the media is influenced by the political or financial goals of its owners. Clear examples of this are some state-owned media companies or party-led magazines and newspapers. A medium that sells advertising space often thinks twice before criticising the actions of its customer companies or any parties closely related to them. This is problematic for the principles of freedom of speech and impartiality.

## **Article format crams the world into a pre-shaped mould**

A news article is the most common and standardised of all journalistic story concepts. It includes the smallest amount of the writer’s own opinions or comments, or at least that is how it ideally should be. A news article

also, however, is always written by someone.

Many questions of power and responsibility are related to news production, as the format is prone to presenting simplified information with often limited space given to explaining the backgrounds of the news event. Thus, presenting the world as news creates simplified, negative and conflict-centred knowledge, especially about geographically remote locations.

For example, the news coverage of Western world-based international news agencies on Africa becomes the topic of discussion every now and then because of the one-dimensional picture of famine, poverty and war that it paints of the continent. The picture is increasingly incorrect as, in 2019, four of the world’s five fastest growing economies are in Sub-Saharan Africa.

The second form of power is the storification of journalism. This refers to the broad phenomenon of portraying things and events as stories in journalism, especially in feature articles and in magazines. This is often justified as journalism also aims to entertain and to commit the audiences as readers of the journal. That’s why journalists try to portray things and phenomena in such a form that the readers and viewers become hooked.

Despite this justification, when information is formatted into a story, journalism sometimes creates fictional causalities and makes people look good or bad, heroes or villains. Additionally, for example magazines have a tendency to portray the lives of people they interview in an unreasonably interesting and favourable fashion. Everyone knows the story format: “she overcame her difficulties with her political career”, “he lived through a hard divorce”.

All in all, when journalistic stories are produced and consumed, it is good to keep in



mind that reality is rarely a black-and-white heroic tale that advances smoothly and with a purpose.

## Lies, damn lies and statistics

Statistics and Gallup polls can at first glance seem like a reliable and objective way for the media to convey information. Still, the worn saying “lies, damn lies and statistics” encapsulates something essential about statistics and averages. When a newspaper conducts a questionnaire that receives answers from the readers, and the results are published sensationally as “the will of the people”, journalistic power is at work.

Firstly, already the phrasing of the question carries great importance. For example, when asked whether the respondents support the idea of higher taxes, the answer is often ‘no’. However, when they are asked whether the level of health care and other services should be maintained even with taxpayers’ money, the answer is more often ‘yes’.

Additionally, the result of polls is influenced by who is being asked. For example, newspapers have different readerships that are often politically profiled. The result of questionnaires that measure the political outlook of readers must therefore never be used to draw conclusions about the public as a whole.

The varying types of conclusions that can be drawn from statistics can be considered the third form of power use. For example, averages do not show how widely the results were dispersed or where the extremities lay. If half the population earns \$10,000 per month and half \$100 per month, the average earnings are \$5,050 per month. However, as the average doesn’t always paint a truthful picture, journalists are encouraged also to

look at the median value of statistical information. The median is a value that represents the number that is in the middle when the results are put in order. In this extreme example case, however, not even the median would paint a good picture because, with an even number of data, the median is the average of two middle numbers resulting in \$5,050, the same as the average. The only truly truthful way in this case is to describe the situation with words or infographs.

Gallup polls can also be conducted in a discriminatory manner or so that they create a false feeling of power over laws and regulations. For example, if a magazine asks its readers whether a teacher who belongs to a certain ethnical, religious or sexual minority should be allowed to work in the profession or should be dismissed, this might at first glance seem a harmless use of freedom of speech. But to ask such a question in a poll is irresponsible, as the question is basically asking the reader whether the constitutional fundamental rights of minority citizens should be limited. Posing such a question places the supposed reader to above people from the particular minority, and gives the impression that constitutions can be changed quickly and without lengthy democratic processes, just based on majority feelings or opinions.

Gallup polls and statistics also legitimise popular and majority opinions. When it makes the news that the majority of the population is against immigration, for example, expressing such opinions out loud becomes more acceptable. Likewise, as an example, if a poll on party popularity is published before an election, it might indeed have a self-fulfilling effect on the matter. Theoretically speaking, many societal phenomena such as politics and market economics are so-called “level two chaotic systems”. In more simple

terms, this means that they are chaotic (very complex) but they also react to predictions made about them. This fact is by no means a reason not to publish a poll – it is just good to remember that publishing predications may later have an effect on the matter under scrutiny.

## **Media and science have much in common – and many differences**

Science – especially related to health, history, nature and technology – is a much-used source of information and a popular topic in news and journalism.

Science and journalism have much in common. Both strive to disseminate as truthful information as possible. Both seek to correct their mistakes, and neither is allowed to plagiarise or lie.

Despite similar principles, the characteristics of science and journalism differ. In journalism, the news criteria favour cases that are unprecedented, unexpected or even weird. On the contrary, science is slow and most of the research data confirms facts that are already known. The poorer a research finding fits into science's current understanding of the world, the more likely it is that the world of science will consider it unreliable – not a scoop. This is why, whenever news from a single study is reported, it is important to place the findings in context.

In addition, the crisis of revenue logic in the media due to digitalisation has affected the journalist's ability to tackle science topics responsibly. A journalist covering science must often handle topics in their field of work, which they are not familiar with beforehand. As the workload increases, there is less and less time to investigate the back-

ground or revisit the original research articles.

In situations like this, the reporter often has to trust experts in the field such as the scientific community or officials. This is why being able to identify the true experts is important for the reliability of news. Just being a scientist or having a Ph.D. does not qualify a person to comment on all research. Also, researchers have a variety of goals and motives. They make mistakes and sometimes they deliberately cheat.

In the media, the impartiality of articles is often striven for by bringing two people or groups that represent opposing views into a juxtaposition. This is justified, for example, when presenting the arguments in topical political debate.

However, when facts and scientific information are being handled, the form may mislead the reader. Not all sources are equal, and not all research is of the same high standard. Even though there might exist contrary research results on a certain statement, the scientific community may be unified in support of one of the positions. It might be possible, for example, that, of 100 studies, 99 say that X is true and only one has produced the opposite result that X is false. The lone opposing result should belong in the error margin, not as the second party in an impartial debate. Impartiality that juxtaposes two opposing results in this example is structural but not truthful.

Misleading juxtapositions have been seen, for example, in the case of news reporting that handles climate change. The international scientific community has for decades been practically unanimous about the fact that climate change is real and is primarily caused by humans. Still, however, climate sceptics are sometimes heard and given their say in the name of impartiality.



## How to recognise an unreliable source in science

These questions may help you to recognise when your source is not reliable.

1. Does the source talk about conspiracy theories? The occurrence of conspiracy claims is a clear indication that the author may be confusing imagination with reality.
2. Does the source say that there is no research to back up the claim or refute scientific methods altogether?
3. Does the source present wonderful and revolutionary results? Revolutionary results are rare in science. If the claim is miraculous and astonishing, it is often incorrect.
4. Does the source use a charismatic individual to justify the claim instead of facts? Riding on the back of the name of a charismatic individual or guru is a common feature of unreliable sources. Typically, despite an impressive title, no academic background or other signs of real-life expertise can be found about the guru from other independent sources.
5. Does the source benefit financially from the claim? Does the source sell a product that is supported by the claim?

**Reflection:** Can you come up with more rules of thumb?

---

Source: Juhani Knuuti, Turun Sanomat 2017 (Translation and modification by the author).

## Discrimination, stereotyping and picking experts

How are experts commonly picked and why? Who gets to speak and who is spoken about?

Social norms and stereotypes are created in speech and actions. When producing and circulating information, journalism also spreads a worldview. Journalism does not merely reflect reality, it creates it. In other

words, from the point of view of media consumption, the media moulds our views of the world in many ways, both in positive and negative senses. Some of the negative effects are due to unconscious and biased decisions made by journalists. That is why a critical mindset is always needed when analysing media content.

Stereotypes have a bad reputation, but in fact all people make sense of the world

through stereotypes. If this did not happen, the human brain would be filled with an array of knowledge fragments. Without the capability to organise things automatically according to stereotypes, it would be hard to put together connections and orders of importance. This doesn't mean to say that people in general and journalists in particular should not resist harmful stereotypes.

One element of reporters' and the media's use of everyday power is that they pick the words and angles from which the world is discussed. As journalism is the product of its cultural and social environment, it easily keeps repeating the same stereotypes, which dominate surrounding society. Also, the prejudices and stereotypes that individual journalists hold influence the content of journalism.

One form of distortion is normativity, the presumption of a norm or the natural state of things or people. Norms are presuppositions about what people are like and what they should be like. They regulate perceptions of gender, religion, skin colour, language, livelihood, nationality or sociality. The stronger a norm is, the more difficult it is to perceive. In general, norms become visible when someone breaks them.

Additionally, reporters are human beings, and their attention and learning are biased. Research has been able to show that a person most easily notices and learns things that reinforce their preconceptions about the world. This is called the confirmation bias. Reporters, while doing their work, become more easily convinced about knowledge that supports their own values and worldviews than knowledge that questions them.

Our subconscious biases may also affect the news in other ways. When choosing whom to interview for a story, a busy journal-

ist will often pick the expert already known to the media. That is, those people get to speak who already have the most influence. This is influenced even further by people's subconscious and culturally defined values. For example, characteristics that convey expertise are considered to be a deep voice, quick-wittedness and confidence, all of which have been traditionally considered male. If experts are then picked on these grounds without critical reflection, the male-dominated societal order is reinforced. In addition, in many countries, the key political and financial positions are still held by men, so a journalist who wishes to enhance equality encounters difficulties in trying to find a woman to give an expert opinion.

This, based on statistics, is then exactly what is happening. According to the international non-profit organisation the World Association for Christian Communication's (WACC) 2015 Global Media Monitoring Project (GMMP), 76 percent of people working in the news were male and only 24 percent female, exactly the same as five years earlier in 2010 when the organisation published its previous report. When investigating topics featuring a female interviewee, GMMP noticed that, compared to the portrayal of men, women were more commonly portrayed as victims or based on their position in the family. Certain groups of women such as poor older women or those belonging to ethnic minorities were even less visible than others. Female reporters were also more commonly made to report mellow topics such as family, lifestyle, fashion or art. When it came to the reporting of leadership positions, women were an exception. All in all, among the key findings, GMMP 2015 reveals that "the rate of progress towards media gender parity has almost ground to a halt over the past five years."



## Women in Palestinian media

Women comprise about half the population of the world. However, the presence of women in economic reports was only 2 %, while the percentage of women's presence in the news was 14 % in 1995 and amounted to 16 % in 2010, the last year of reliable counting. Women's presence in stories related to politics and the government recorded a percentage of 10 %.

In the West Bank and the Gaza Strip, women constitute 49.2 % of the total population, while their participation as speakers in news broadcasts by Palestine TV during the period 14–27 May 2010 was only 15.5 %.

In addition to these quantitative indicators, there are other aspects relevant to the content and nature of coverage and the resulting social impact. However, measuring this impact needs a critical

and examining look at the type of editorial processing of media content. In this respect, the following features can be monitored: the stereotypical image of women that confines her role to child-bearing and taking care of children still persists; the exploitation of the image of women as victims in order to gain political sympathy; the use of women's bodies to promote consumer commodities; treating women condescendingly; handling women's rights as if it is a favour or dealing with women's successes with astonishment, doubt and disapproval.

**Reflection:** Why do you think there are so few women working in journalism in Palestine? Does it matter? Do you think that there is a difference between the work of female and male journalists?

This is how media, which faithfully reflects reality, maintains the gender divide. Prejudices, stereotypes and unbalanced reporting establish the power relations between groups and generate fruitful soil for the growth of discriminatory attitudes and practices.

The media moulds our views not only about gender roles, but also about people from

other cultures. Presenting content which is openly racist is usually not permitted. The media has been criticised, however, for portraying the role of immigrants and different minorities in an otherwise negative light. For example, immigrants may be discussed in the media in a problem-centred way and through the mouths of officials. In conflict cases, the origin or the ethnic background of



## Congratulations on an all-male panel!

Did you ever look around a meeting or lecture room and wonder where all the women were?

Finnish researcher of nuclear weapons policy and Doctor of Social Sciences Saara Särmä comments on the theme in her humorous Tumblr blog, which has attracted much international attention.

The blog, started by Särmä in 2015, brings together pictures of male panels, "manels". Manels are expert panels, all the participants of which are male, whether the topic is politics, technology or women's rights. The website is sarcastically entitled "Congrats, you have an all-

male panel!" Congratulations indeed. Again, there are no women participating! The photographs feature a superimposed picture of David Hasselhoff giving a thumbs up. Särmä also publishes pictures of all-white panels.

The popularity of Särmä's blog is based on the fact that it is able to handle a serious issue through humour. Discussions in the public eye are still mainly held by men.

But can a blog also have an effect on the phenomenon underlying the humour, and how?

---

Read more: [allmalepanels.tumblr.com](http://allmalepanels.tumblr.com)

the perpetrator often makes the news only if they are not part of the majority population. This, at its worst, creates an illusion that there are more perpetrators from certain ethnic or minority groups.

As an example, in 2019, there is an ongoing discussion about whether acts of violence committed by Muslims in Western countries are more easily labelled as terrorism or cultural conflict, whereas the same type of crimes committed by the majority population were explained by disturbed individuals, mental health problems or general malaise. Minorities may also be portrayed in the media as an exotic curiosity. A sole representative of a certain minority can also be unfairly asked to talk for their whole group.

All in all, minorities are most often the objects of news articles, not active and equal actors such as decision-makers, journalists or experts in their own field, so the best way to prevent discrimination in the media would be to have minority representatives as producers of media.

The only way for a journalist to prevent the influence of stereotypes and bias on the quality of their journalism is to become conscious of their own presuppositions and always to consider their own knowledge and outputs with a critical eye.

# 3

## The ETHICS and SELF-REGULATION of JOURNALISM

**E**thics can be concisely defined as the reasoning behind human action and morals. Whilst morals refer to the practical value choices a person makes, ethics refer to the principles behind them. The ethics of journalism have many aspects including legal, instructional and professional.

The work of a journalist is ultimately controlled by national and international laws. Usually, in free democracies, the ethical code of journalism is stronger than the local law: not everything that is legal is necessarily good practice. International law, international agreements and domestic law are thus not the only systems that regulate the work of a journalist.

## Ethical principles of journalism

According to the basic division, there are two kinds of ethics: duty-based ethics and consequentialist ethics. In the case of journalism, duty-based ethics stress the importance of truth, while consequential ethics focus on societal good. If a journalist thinks that it is most important that a story is true and that the facts are right, they follow duty-based ethics. On the other hand, a journalist may think that the effects of a cause are the most important aspect and, as a result, follow consequentialist ethics. Does the article offend someone? What kind of effects will the publication of the article have? Can the publication of a certain article do more harm than good, even if the facts used are correct?

The ethical code of journalism is much the same as the ethical code of science. As in science, in journalism it is also important to be objective, critical, autonomous and progressive. Objectivity and criticality describe the relationship with knowledge. Autonomy should be achieved, at least from funders, owners and the state. The ethical code of progressivity refers to the principle that science and journalism should create new information.

If the foundations of journalism ethics are tracked far enough, one finds that they are based on various international agreements and declarations, such as the UN Universal Declaration of Human Rights and regulations of international law. The UNESCO declaration regarding mass media (1978) and the Paris Declaration (1983), which were backed by numerous journalist associations, define the ethical guidelines more accurately in questions related to media and journalism. They are based on the basic principles of international law, democracy and independence.

It is easiest to handle ethics through duties and freedoms. The most important freedom that journalists use is the freedom of speech, which is also defined in legislation. The journalist is responsible to the following parties:

- Society, the general public
- Customers, supporters and subscribers
- Their employer, the corporation
- Colleagues, the professional community
- Themselves, their conscience.

In 1991, a Finnish researcher, Tiina Laitila, studied 30 sets of journalist ethics publications, and the result shows that journalists think they are primarily responsible to their audience and the sources and objects of their information. Their employer and the state are much more seldom mentioned in ethical rule-books.

## The self-regulation of journalism

In their everyday work, journalists are mostly guided by self-regulation. Self-regulation refers to the ethical guidelines of the professional journalistic community. The self-regulation system with its guidelines is independent of the state and legislation, aiming to secure the truthfulness and accuracy of journalism as well as the rights of reporters and interviewees, to name but a few examples.

The self-regulation system of the media is an attempt by editorial office professionals to create, adhere to and oversee voluntary editing guidelines, and to open the learning process relating them to the public. The system makes the press independent: the media carry their responsibility for the quality of public discussion but still maintain perfect editorial independence.



# i

## Why do you need self-regulation when there are laws?

The Organization for Security and Co-operation in Europe (OSCE) lists arguments for self-regulation:

- **Self-regulation benefits journalists.** It increases readers' trust in the media, as the media supervises its own mistakes. Readers have the opportunity to critically assess whether the media meets the guidelines laid down by the ethical codes. This is particularly welcome in new democracies, most of which are also unfamiliar with an independent press. At the same time, it protects the right of journalists to be independent, and allows them to be judged for professional mistakes not by those in power but by their colleagues.
- **Self-regulation benefits readers.** They can complain about articles for free – a legal process would be costly. The resolution of disputes is quicker than in court, and the mistakes are acknowledged publicly by the press.
- **Self-regulation increases the independence of media,** as the offences journalists commit are punished by their colleagues, not by state officials. When it comes to correcting factual errors or violations of personal rights by the press, satisfaction over the judgments of self-regulatory bodies reduces pressure on the judiciary system to sanction journalists.
- **Self-regulation reduces the power of the state over media.** When media has the responsibility to adhere to good journalistic practice for the sake of itself, the state does not need to interfere in its activities so energetically. Self-regulation thus secures the independence and quality of journalism. Self-regulation is not a question of self-censorship, but of the endeavour to secure conditions beneficial to the realisation of the freedom of speech. It is about establishing minimum principles on ethics, accuracy, personal rights and so on, while fully preserving editorial freedom on what to report and what opinions to express.
- **Self-regulation benefits democracy.** Democracy is about a shared culture of disputing in a rational and fair manner. Governments, even if freely elected, are participants in a political contest, and therefore not best-suited to enforcing rationality and fairness. Media self-regulation is an effort to impose democracy's political culture, independent of political forces. It also advances the transition from a government-owned, state-controlled press to one owned and controlled by civil society.

The principles of self-regulation have been written down in the ethical codes of journalism. An ethical code is a set of guidelines that is often more precise than the law. It defines the reader's, journalist's and interviewee's rights. It also defines the basic principles guiding journalistic work such as truthfulness and objectivity. Ethical codes are also nation-specific because of differences in cultures and legislation.

An individual media corporation can also have its own ethical guidelines. Well-known examples include guides from BBC and Associated Press (AP). Additionally, different media can have their own codes: for example, separate ones for the press, television and online media. The basic principles remain the same, however, regardless of the country and medium. Some other professional communities also have their own ethical guidelines. The ethical code of journalists can be compared to the physician's Hippocratic Oath. The main difference is that new physicians are required to swear to uphold specific ethical standards, whereas following ethics is just a question of conscience for journalists.

It is essential for journalists themselves to have created an ethical code that is not dictated by the owner of the media or the state. If the government interferes in the writing of the guidelines, the whole idea of self-regulation falls apart. It is also important for the code to be updated when needed. For example, the quick development of online journalism has necessitated the modification of codes to meet today's standards.

It is worth remembering that the existence of professional ethics in itself does not guarantee high-quality and independent journalism. The professional community can also abuse the ethical guidelines and reinforce

their own position with it. Even questionable practices can be easily justified by the ethical code, so professional ethics should also remain the object of critical observation by independent parties such as a public council for mass media.

In principle, when a magazine, newspaper or media channel acts in a non-ethical manner, anyone can submit a complaint concerning a breach of professional practice. Unlike legal complaints, such a complaint is handled free of charge.

## **Journalistic guidelines share similarities globally**

Due to cultural and legislative differences, it is not an easy task to create global guidelines for journalists. It is nevertheless worth noticing that consumers of media seek out information not only from national but also from international media. For this reason, there is a demand for internationally agreed guidelines.

There are existing global guidelines such as the aforementioned Paris Declaration of 1983, and also a nine-item ethical rulebook that has been compiled by an international journalist association, the International Federation of Journalists (IFJ). The latter in particular is quite broad as the rules are a compromise between journalist associations from around the world.

The main values include truth, independence and harm minimisation. For example, the first of the IFJ guidelines is: "Respect for truth and for the right of the public to truth is the first duty of the journalist". Guideline number four states "the journalist shall use only fair methods to obtain news, photographs and documents".

Questions immediately arise from the guidelines: How is truth defined? What about methods for obtaining information? Which of them are fair and which unfair?

To give more accurate guidelines, one must focus on the guidelines of a certain country. That is why this chapter offers a selection of basic principles most common in European countries. More accurate examples of guidelines used in this guidebook are mainly from the Finnish journalists' guidelines. There are also examples from international, national and in-house guidelines. In the end, surprisingly, despite cultural and political differences, the rules from different countries have much in common.

In this guide, the ethical guidelines of a journalist have been grouped in the following manner:

1. Acquiring information, publishing and correcting information
2. The professional position of a journalist
3. The rights of an interviewer and an interviewee
4. Private and public.

## **Guidelines for acquiring information, publishing and correcting information**

One of the most common ethical guidelines of a journalist is truthfulness. It is the journalist's duty to sift out truth from behind assumptions and rumours. A journalist must not leave unpublished or otherwise keep secret information that is crucial to the news, even if this might water down a juicy article, or take the edge off a story. In many cases, a news topic that at a glance seems meaningful, interesting and surprising flattens out to be boring and ordinary, or even turns out to

be downright wrong when it is examined in greater depth. This feels frustrating, but it is an essential part of journalistic work. Despite the temptation, a journalist must not make news out of information that has proven to be false, even if this might serve a good cause and even if the reporter knows that they will not get caught.

A second important value is honesty, which is most often realised by using only direct methods in gathering and presenting information. It is recommended that a journalist announce their occupation while conducting their work and otherwise remain open in their work.

It is possible, however, to deviate from this if there is no other way to obtain significant information. For example, it would be hard to get information about a closed community if the reporter had no access to the community. If a journalist sees that something is happening within the community that should be published, they may keep their occupation a secret. A lively discussion was raised in Finland in 2012 when a journalist from the country's biggest newspaper, Helsingin Sanomat, infiltrated the camp of a Christian society, which organised courses aiming at changing sexual orientation from homosexual to heterosexual. The newspaper justified its actions by stating that, without such infiltration, it would not have been possible to find out what actually happens during the courses: previously journalists had been unable to gain access to the camps.

Nevertheless, guidelines on such a topic vary individually. The Washington Post's guidelines regarding this matter are strict: "Reporters should make every effort to remain in the audience, to stay off the stage, to report the news, not to make the news. In gathering news, reporters will not misrepresent their

identity. They will not identify themselves as police officers, physicians or anything other than journalists.”

A journalist must also differentiate between facts and opinions. The reader should be able to tell which parts of a text express a personal opinion, and which strive for the objective conveying of information. According to the Austrian code: “Readers shall be left in no doubt as to whether a newspaper item is a factual report, the reproduction of the views of a third party or third parties, or a comment.”

The same applies to the use of illustrations and sound. Also, within a single article, it should be clear which part is the journalist’s own description of the event, and which part comprises quotes by the interviewee. In practice this is often done by using quotation marks to signify the interviewee’s utterances.

The difference between truth and opinion also applies to advertising. The division between announcements and edited content should be clear. This differentiation has been made more difficult, for example by the emergence of advertorials.

Remaining critical is an important value that guides a journalist’s work and acts on many levels. First of all, sources of information should be scrutinised with a critical eye. The Finnish guidelines for journalists highlight that “[being critical] is most important in controversial topics, as the source of information may have a will to benefit or to harm”.

Many kinds of parties contact editorial offices, and journalists should always stay alert as to why. Does the person contacting the press want positive publicity for themselves or their company, negative publicity for someone else, or publicity for a cause that they think is important for some other reason? The article should primarily bene-

fit its reader and society, not the object of the article.

In addition to a single source of information, some of the guidelines highlight the critical mindset in a broader way. According to the guidelines of the international news agency Associated Press (AP): “A newspaper should provide constructive criticism for all groups in society”. The paper, the TV channel or the radio station should thus remain critical in relation to what it covers, so that the entirety of its offerings convey a critical image of society. The US-based Society of Professional Journalists (SJP) especially stresses criticism towards decision-makers.

Additionally, according to the guidelines, a journalist should “give a voice to the voiceless” and “seek sources whose voices we seldom hear”. Journalists should therefore pay attention to which parties get to provide their voices. SJP’s guidelines thus take a stand on a common phenomenon according to which the more societal power you hold, the easier it is for you to get your voice heard through the media.

A journalist should also be critical of themselves. A journalist must pay attention to how their own values and experiences affect their work. Even if a news article seems impartial and the journalist lets the voices of opposing parties be heard, a strong opinion of the journalist can influence the tone of the article. A way for a reporter to remain critical of themselves is to publish a comment or a column alongside the article, where their opinions are laid bare.

Nearly all ethical code publications of journalists stress the accuracy and validity of published information and the meticulousness that must be used to check it. Even though work is in practice often done in a hurry, this must not be a reason why facts

# i

## Excerpts from guidelines for seeking and publishing information

- No story is fair if it omits facts of major importance or significance. Fairness includes completeness.
- No story is fair if it includes essentially irrelevant information at the expense of significant facts. Fairness includes relevance.
- No story is fair if it consciously or unconsciously misleads or even deceives the reader. Fairness includes honesty – levelling with the reader.
- No story is fair if reporters hide their biases or emotions behind such subtly pejorative words as “refused,” “despite,” “quietly,” “admit” and “massive.” Fairness requires straightforwardness ahead of flashiness.

---

The Washington Post Standards and Ethics

- The journalist must aim to provide truthful information. Information should be obtained openly. The journalist is encouraged to make known his/her profession during the course of an assignment. If matters that are in the public interest cannot be otherwise investigated, the journalist may carry out interviews and obtain information by means that depart from standard practice.
- Information sources must be approached critically. This is particularly important in controversial issues, since the source of the information may be intended for personal gain or to damage others.
- A news item may be published on the basis of limited information. Reports on subjects and events should be supplemented once new information becomes available. News events should be pursued to the end.
- Essentially incorrect information must be corrected without delay and so as to reach, to the highest extent possible, the attention of those who have had access to the incorrect information.
- The degree of attention brought to the correction must correspond to the seriousness of the error. If there are multiple factual errors in an article, or if the incorrect information might result in significant damage, the editors must publish a new article in which the incorrect information is identified and corrected.

---

Guidelines for journalists, the Council for Mass Media in Finland

remain unchecked. A journalist and at least the editor of the publication are responsible for the correctness of the information they have presented. All information must be checked thoroughly, even when it has previously been published elsewhere. In the case of errors, journalists must correct them without delay.

In online publications, it is not enough to remove the false information or to delete the article. The audience must be informed of the error and the fact that it has been corrected.

The principle of openness also applies to correcting errors. It is good to tell the audience in a straightforward way what kinds of practices and principles the media has regarding errors and corrections.

The source of the information used should be published. Only when this is done does the audience have an opportunity to assess

the trustworthiness of the sources. Facts that have already been published must be checked as carefully as new ones. The fact that a piece of information has been published in another paper does not make it correct. This is how journalists avoid circulating mistakes made by others.

## Guidelines for the professional position of a journalist

According to IFJ's rules, journalists should decline a bribe that is offered in any form, whether it be aimed at publishing or preventing publication. Forbidding bribery is thus accepted worldwide by journalist associations.

The wider realisation of independence is more reliant on culture. The media is often bound to something relating either to finance or politics. IFJ rules do not mention, for example, independence from the state government. According to the Finnish guidelines, resolutions regarding content must be made on journalistic grounds. The decisions regarding publication, article topics and perspectives should, in other words, be made within the journalistic body. Conversely, journalistic bodies should make the decision themselves not to publish a story. All forms of pressure and attempts at restraining must be rejected.

Complete independence is impossible: media is always owned by somebody, and the ownership of media is ever more centralised these days. A media corporation can own both a chain of movie theatres and a newspaper. If the newspaper publishes a story on the chain of movie theatres, ownership relations may affect how critically the journalist handles such in-house issues.

Affiliations should be known by the reader, regardless of whether the ownership has



### Reflection:

- Find a journalistic story in which someone has been interviewed. Why was this person chosen and who else could have been interviewed besides them?
- Can you think of journalistic pieces where it was not easy to differentiate facts from opinions?
- By which methods have you noticed the media correcting their errors?



## Excerpts from guidelines for journalistic professionalism

- A journalist is primarily responsible to the readers, listeners and viewers who have the right to know what is happening in society. Decisions concerning the content of media must be made in accordance with journalistic principles. The power to make such decisions must not under any circumstances be surrendered to any party outside the editorial office. The journalist has the right and obligation to resist pressure or persuasion that attempts to steer, prevent or limit communications.
- The journalist must not misuse his/her position. The journalist may not deal with issues that may lead to potential personal gain nor demand or receive benefits that might compromise their personal independence or professional ethics. The journalist is entitled to refuse assignments that conflict with the law, their personal convictions or good journalistic practice.
- It is crucial to observe good professional practice when using the work of others. Sources must be mentioned when information has been published by other parties.

---

Guidelines for journalists, the Council for Mass Media in Finland

- This newspaper is pledged to avoid conflict of interest or the appearance of conflict of interest, wherever and whenever possible. We have adopted stringent policies on these issues, conscious that they may be more restrictive than is customary in the world of private business. In particular:
  - We pay our own way. We accept no gifts from news sources. We accept no free trips. We neither seek nor accept preferential treatment that might be rendered because of the positions we hold. Exceptions to the no-gift rule are few and obvious – invitations to meals, for example. Free admissions to any event that is not free to the public are prohibited. The only exception is for seats not sold to the public, as in a press box. Whenever possible, arrangements will be made to pay for such seats.

---

The Washington Post Standards and Ethics

affected the tone or content of the story. That is why, for example, the Finnish guidelines for journalists state that “while handling issues that are significant to the media in question, the corporation or its ownership, a journalist should make the context clear to the reader, listener and the viewer.” In practice, this can be done, for example by adding a note to the end of the article that the corporation mentioned in the article belongs to the same conglomerate as the newspaper.

Receiving bribes can also be viewed more broadly: the reporter should not try to make personal gain from their occupation or abuse their position. They must not handle issues that may result in an opportunity for personal gain, nor receive benefits that can undermine independence.

The freedom to express and comment is a natural counterpart to the previous chapter’s rule that outside influence and pressure should be rejected. Perfect freedom of expression is impossible to achieve under pressure from an outside party. Freedom of expression is not only about the right to express, but even more importantly about people’s right to know.

In some cases, the journalist has the right to decline to work. Cases like this include news concerning their close relatives. When a journalist reports, for example, the political

actions of their kin, it is easy to see why their credibility might be undermined. The audience will probably assume that the journalist is biased, even if this is not the case. The journalist cannot likewise be obliged to break the law. Occasionally their methods of information-gathering can be viewed as a grey area by the law, but such assignments require voluntariness.

A journalist must respect the copyright law and practices of their country. At their most blatant, copyright violations are copying parts of an article from somewhere else, something that should be avoided at all costs.

## Guidelines for the rights of an interviewer and interviewee

The relationship between the interviewer and the interviewee is confidential. One of the principles of good journalism is that the interviewee can have complete faith in the fact that the interviewer will not twist what they are saying by leaving essential parts out, or by putting words into their mouth. The interviewee has the right to know in what context and for which publication they are being interviewed, and whether what they say is meant to be published, or whether it will be used only as the background material for the story.

Interviewees have the right to their quotations and their opinions. According to good journalistic practice, the interviewee is entitled to read the quotations that are attributed to them before publication and possibly suggest corrections to them. All this takes place if the publication schedule permits.

This may sometimes lead to conflicts between the journalist and interviewee. Occasionally a situation might arise where an in-



### Reflection:

What are the professional or corporate affiliations of the media outlet you follow?



# i

## Excerpts from guidelines for the interviews

- Interviewees have the right to know in advance the context in which their statements will be used. They must also be told if the interview will be used in multiple mediums. The interviewee must always be told whether the conversation is intended for publication or will be used exclusively as background material.
- It is worthwhile consenting to interviewee's requests to read their statements prior to publication, if the editorial deadline permits. This right only concerns the personal statements of the interviewee, and the final journalistic decision cannot be surrendered to any party outside the editorial office.
- The interviewee's refusal to allow the publishing of their statement must be complied with only if the circumstances following the interview have changed so significantly that the publication of the interview could be viewed as unjust.
- If the intention is to present information about the activities of a clearly identifiable person, company or organisation in a manner that would present them in a very negative light, the object of the criticism must be granted the right of reply on the issue in question. If it is not possible to simultaneously hear the views of the parties involved, it may be necessary to give the party who has received the very negative publicity the opportunity to be heard afterwards. If this is not done, good journalistic practice calls for the publication of the comment of the criticised party.

The Council for Mass Media in Finland

interviewed politician receives information after an interview according to which the interview they gave might put them in a bad light.

In a situation like this, the interviewee naturally tries to prevent the publication of the article. In principle, they do not have the right to do this unless the situation has significantly changed since the interview.

When handling very sensitive topics, the reporter should record the interviews so that afterwards the interviewee cannot deny what they said, or blame the journalist for misrepresenting something. When important

politicians or figures of the corporate world are being interviewed, the public relations officer, attorney or another representative of the corporation or politician might also be present, recording how the interview is going. The representative may also interrupt or tell the interviewee not to answer if they are about to say something, which could harm their public image.

Ultimately, however, the power over alterations and publishing remains with the journalist. An interviewee cannot prohibit the publication of a story. It is good to



## Reflection:

Can you come up with examples of situations where an interviewee might try to prohibit the publication of the story after they have been interviewed?

adhere to common sense: if an interviewee later denies what they said, it is worth considering whether the utterance has such societal significance that it is worth publishing.

The interviewee also has the right to comment on the piece of news afterwards, if they see it as erroneous or offensive. If the interviewee or the object of the article feels that an already published article is offensive to them, they are entitled to publish a reply. If the article contains factual mistakes, the paper must publish a correction of the erroneous information.

The right to reply does not, however, apply to all news. It does not apply to regular culture criticism, political, financial or societal assessment or other such presentation of opinion. Ultimately, the offensiveness of an article is determined by the editor-in-chief of the publication, who has the power to grant right to replies.

## Guidelines for private and public

What is a journalist permitted to publish, and in what manner? What must they publish and what cannot under any circumstances be published?

The reporter must respect the sources and objects of their information, and their priva-

cy. The rule of thumb is that the more the object of the article has received publicity in the past of their own free will, and the greater their societal power, the less privacy they must be granted. If a politician is suspected of a crime, the societal significance of the issue is more important than the protection of the politician's privacy. In this case, it is justifiable for the topic to be made into a story. Instead, if a "regular" person is suspected of the same crime, due to the protection of privacy it is often not justified to publish the name of the perpetrator. The harm that is caused to the individual by the publication of the story might be greater than the reader's right to know the perpetrator's name.

The media often has accurate guidelines about the publishing of criminals' names. In the Finnish media, the rule of thumb is that the name of a person who has been sentenced can be published, if the sentence is greater than two years of unconditional imprisonment. Publishing names must always be considered on a case-by-case basis in order not to cause harm to the victims of the crime. For example, the names of people who have been sentenced for sexual offences towards minors or domestic violence are often left unpublished, so that the identity of the victims is not revealed against their will.

The ethical guidelines of the American Society of Professional Journalists proclaim as follows: "Show compassion for those who may be affected by news coverage. Use heightened sensitivity when dealing with juveniles, victims of sex crimes, and sources or subjects who are inexperienced [in dealing with media] or unable to give consent [to the publishing of the information]. Consider cultural differences in approach and treatment." The society's guidelines also state that it is not always ethical to publish information that is legally available.



## Do public figures have a right to privacy?

The code of conduct of journalists states that the right to privacy of public figures like government ministers is narrower than for “laypeople”. If a politician is suspected of a crime, the societal significance of the issue is more important than the protection of the politician’s privacy. But the right to privacy still exists. So, for example the ministers also have a right for privacy.

For example, a minister’s health and medical history is a personal matter as long as there is no major reason to suspect that it might affect his performance.

The right to privacy also protects a minister’s personal money spending habits. This means that the public does not have a right to know, for example,

how much they spend on a family member’s wedding reception. This does not, however, include cases where there is suspicion of corruption, like for instance evidence that they made use of public money to finance the reception.

In Finland, tax records are public. This helps responsible journalists to track the money flows of important decision-makers, but it also makes misuse of the information possible.

**Reflection:** Can you think of examples of cases that bring into question a public figure’s right to privacy?

Universal principles of equality and non-discrimination also apply to journalism. A journalist must take care of the fact that equality is realised through refraining from discriminating against anyone based on race, ethnic origin, religion, gender, social

class, profession, disability or other personal characteristic.

## Guidelines for protection of sources

It has been said that the protection of sources is one of the strongest data acquisition methods for a journalist. The sentence sums up nicely the position of sources in journalism.

Protection of sources makes it possible for citizens to bring to light information through the media about malpractice committed by policy-makers and officials without fear of repercussions or retaliation.

A classic example is the Watergate scandal, which led to the resignation of US President



### Reflection:

Under what circumstances do you think the name of a suspect or the name of a convicted criminal should be published and under what circumstances not?

Richard Nixon. Eavesdropping practised by Republicans would not have been exposed without an anonymous source.

The journalist has the right and duty to keep the identity of a person who supplies confidential information a secret. The journalist must never reveal their confidential sources, not even under pressure. Attempts at such pressuring should also be fended off. Achieving the confidence of the sources de-

mands the journalist's time and energy, but it can be lost in the blink of an eye. Journalists who reveal their sources not only damage their reputation, but also undermine the trust of the whole professional community.

To ensure that socially important sources of information can trust that they will retain their anonymity in the future, journalists must together and alone defend the position of the protection of sources. Protection of



## Tips for responsible reporting

In general, where there is rapid need for information, the need is greater for the verification of truthfulness and accuracy of information and pictures. It is the duty of other journalists to detect and correct misinformation. Therefore, resist the temptation of rapid publishing, be patient and verify.

The code of conduct of the Palestinian Journalists Syndicate (PJS) stipulates the following with regard to the obligations of professional journalists towards the public:

- Pay attention to issues of public opinion interest through providing accurate and verified information and by focusing on marginalised areas and groups
- Do not publish names of victims before verifying their identities or before their families are informed
- Do not publish photos of victims in a way that hurts the feelings of their relatives or the public in general
- Respect the privacy of citizens, including legal entities, except in issues related to public opinion
- Do not disrupt the judiciary and abide by not publishing names or photos of the accused before a court judgment is issued
- Avoid defamation or incitement to violence and hatred against anyone or any party or institution on the grounds of sex, race, religion or political affiliation
- Protect children from media materials that negatively affect their psychological development
- Avoid publishing pornography, inappropriate speech or sarcasm
- Commit to the use of quotation marks when you quote someone.

**Reflection:** What do you think this guideline refers to with "inappropriate speech"?

## How to report terrorist attacks in an ethical manner

The Organization for Security and Co-operation in Europe (OSCE) listed tips for reporting terrorist attacks in an ethical manner in their 2008 *The Media Self-Regulation Guidebook*.

"Acts of terror should be reported accurately and responsibly. Special care must be taken with the wording, which should avoid praise for violent acts and eliminate terms that contain emotional or value judgments. The term "terrorism" is interpreted in various, sometimes opposite ways. As the BBC lucidly puts it: 'The word 'terrorist' itself can be a barrier rather than an aid to understanding. Journalists

should try to avoid the term without attribution. They should let other people characterise while they report the facts.'

Detailed descriptions of what happened, avoiding terms such as "freedom warriors" or "terrorists", increase credibility among the audience. The journalist's goal remains the same as in reporting any story: to let readers make their own judgements."

**Reflection:** Take a look at new archives for recent terrorist attacks in your area. How did the reporters succeed in following these guidelines?

sources is the security and right of the source, not the journalist. Much like working as a journalist, acting as a news source and getting revealed are also life-threatening in many countries.

If the publication of societally important information causes very unfavourable publicity, the editorial office should outline to the audience how the dependability of the anonymous source and the information acquired from it has been ensured.

In some specific situations, a court of law may order a journalist to reveal their sources. For example, in Finland a court may order the journalist to reveal their sources when handling a case where the most severe sentence is at least six years of imprisonment, or if it suspected that handing over information has violated the obligation to maintain secrecy. In Sweden, the protection is even stronger:

the law prohibits officials from even trying to uncover journalists' sources.

The more democratic a society is, the more revelations concerning authorities are tolerated without trying to pressure the journalists to reveal their sources. In authoritarian societies, protection of sources is often weaker.



### Reflection:

Can you come up with examples of situations where a journalist might be pressured into revealing their sources?



## Avoiding harm

Freedom of publication is restricted by a set of regulations to avoid unnecessary harm to others.

For example, one particular example is whether publishing the name of an offender should always be allowed or not. There are two major objections for this.

First is that the victims' rights should always be taken into consideration. It can be argued that the public has the right to know the name of a murderer or rapist in their neighbourhood. However, revealing the names in delicate cases must be considered in terms of whether there is a risk of causing harm to the victim and their family, thus victimising them twice. For this reason, publishing the name of the offender in a case of incest is considered an extreme example of this: it

should not be done since it will easily reveal the victim's identity.

Another example: The public may have the right to know the name of the thief who stole the safe of the school canteen, but revealing the thief's name in newspapers will limit his chances for rehabilitation and reintegration into society. It may be asked whether public shaming just to satisfy the curiosity of others is a proportionate sanction for a rather petty offence such as this – especially if the offender is a minor.

**Reflection:** Can you come up with more examples of situations where information should not be made public in order to avoid harm?

# 4

# WHAT **is** VISUAL JOURNALISM?

**V**isual journalism is a much wider concept than photojournalism. It is essentially creating the overall visual appearance of a newspaper, magazine, TV-channel or so on.

The visual appearance of a media channel, newspaper or magazine is created with typography, photographs, videos, illustrations, cartoons, maps, infographics and other graphical solutions.

Modern online newspapers and magazines have the technical conditions to employ multimodality in journalism. Good examples of pioneers in this field include the British newspaper *The Guardian* and the US-based

newspaper *The New York Times*. These papers have experimented with the use of text, pictures, videos and infographics in the same article offering a multimedia experience that goes beyond the possibilities of any traditional media channels.

## **The basics of photojournalism**

Photojournalism is a form of journalism whose purpose is to deliver news through images, such as photographs, videos and illustrations. The photograph is still the most important form of journalistic imagery.

In traditional newspapers, images direct the interest of the reader. Illustrations help the reader to orient themselves amidst the mass of text and to recognise news topics. The images help illustrate what has happened that day.

In addition, in the era of the internet and social media, the appreciation of photographs and all kinds of visual content has grown steadily. Even though a publication may focus on textual content, visual presentation of the message needs to be taken into account in order for the message to be delivered effectively. Successful visuality gives the impression of professionalism.

A photograph, when published within a journalistic context, is in itself a journalistic product, but its message is built together with the text. The text provides the photograph with a context and dictates how it will be received – and vice versa. A photograph included in printed media is almost always accompanied by a caption. The caption describes where the photo was taken, who are represented in it, what has happened and why the people are there.

Picking images for articles is precise work and, in addition to the photographer, often the reporter, subeditor, layout designer and art director participate in the process. The image, title and introductory paragraph should all be considered to ensure that they support each other. The title must not be in direct conflict with the illustration, but light tension or a contradiction may be an effective way of getting the reader's attention. If the title reads: "A minister marched out of the plenary session", the photograph cannot show the very same minister sitting contently at their seat. Nevertheless, as an example of suitable tension, a news article can quote a politician who says that the cooperation between parties is

going well, while the accompanying image reveals the built-up tensions between the participants.

## **Genres of photojournalism – spot news, illustration and feature photography**

Photojournalism may be roughly divided into three main genres: spot news photography, illustration photography and photo reportages or features. This is just a one example of a division as many others would be also possible.

A news photograph is a product of journalistic culture, and fundamentally it should aim to answer the same questions as a news text: what, where, when, why, how and who. Like a news text, a picture aims for clarity and simplicity and it should be about an event that has newsworthiness.

Illustration photographs, on the other hand, are usually used in journalism to illustrate abstract topics or concepts. They share many similarities with drawn illustrations and are used in similar contexts: both are more often used in feature stories than in news. Unlike spot news photography, they may be very abstract and not necessarily at all related to the locations or people present in the written story. Instead of just illustrating or showing what can be read in the text, sometimes illustrations may bring the article another angle or deepen some aspects of the story.

Feature photography can include several photographic subgenres such as photo reportages or photo essays. The distinctions between these are somewhat blurred, and are largely dictated by the platform of publication, layout, number of illustrations and amount of



text. Unlike illustration photography, feature photography should have to do with a newsworthy event, person or phenomenon in a direct sense, but on the other hand it is generally more liberal and photographer-centred than spot news photography. When photo features are published for instance in magazines, the focus is often on the photographs and layout, while the text is often of secondary importance. The aim, as in the features in texts, is to tell a story through a series of photographs or to transmit the feeling of being present at the event.

## Photojournalist or photographer?

All photographs are parts of visual culture. Throughout the history of photography, there has been debate about whether it deserves a place in the field of art or whether it should be considered merely the mechanic storing of reality. This debate continues today, not only on whether a photograph can be considered art, but also on what kind of a photograph can be considered art.

The differentiation of fields in contemporary photography is based on the specialisation of professionals, organisation and the practices of publishing the images. It is common to sort photographs into the following categories: photojournalism, advertising photography and fine-art photography. In addition to these, scientific documentary photography could also be discussed.

Of these categories, fine-art photography is most commonly thought of as a part of the more general field of visual arts. Photography at news events is rarely considered art, but is not monotonic work either. An image's aesthetic character is also a part of its impact. Many well-known newspaper photogra-

phers have a recognisable style, and the work of photographers who have originally been newspaper photographers has been shown at art exhibitions.

The difference between a photojournalist and a photographer can roughly be said to be that a photojournalist has a better understanding of creating journalistic outputs and, unlike an art photographer, a photojournalist is committed to the code of ethics of journalism. The skillset of a professional photojournalist also includes an understanding of the journalistic work processes in a wider sense, as creating high-quality journalistic output requires much cooperation and coordination between the editors, reporter and photographer. In addition, it is vital that a photojournalist understands the basics of designing a layout of a newspaper, magazine or the TV channel they work for. Ready-made layout templates and stylebooks, which reduce the staff's workload, often limit the photographer's freedom of expression.

Digitalisation has changed the photojournalist's job description drastically. A modern photojournalist uses digital image processing and editing programmes and other software for content production. Contemporary storing devices such as mobile phone cameras, have also made possible the rise of a new kind of citizen photojournalism. Mobile phones have not, however, replaced DSLRs, digital single-lens reflex cameras, as the most important tool of a professional photographer. With professional tools, taking pictures becomes easier even in harsh conditions.

A successful journalistic photo may be technically less than perfect, but due to its information value it can succeed well. The photographer should, however, always strive to reach a technical level at which the conveying of the information does not suffer.

## Shot sizes and composition of a photograph

Whether or not photojournalism is considered visual art, the basics of visual aesthetics apply. There are several easy rules that will help to improve one's skills in both taking and analyzing photos. It is good to remember, however, that all the "rules" mentioned below are guidelines to general aesthetics, and

following them will make the photography appear neutral and thus pleasing to the eye. Obviously, when a professional photographer knows what they are doing, these rules can be "broken" deliberately to create different kinds of meanings.

First, there are eight standard shot sizes that primarily apply when photographing or filming people, and which are useful to know in framing and composition, regardless



1. An **extreme close-up (ECU)** brings out detail, for example a part of a face.



2. A **close-up (CU)** portrays the face of a person with the curve of the shoulder also visible. No excess space is left above the head. The top of the head can be left out.



3. A **medium close-up (MCU)** is framed at the armpits or the chest. No excess space is left above the head and the person is central.

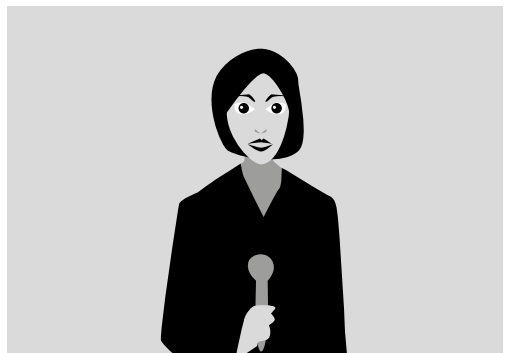

4. A **medium shot (MS)** shows half a person, framed approximately at the navel. No excess space is left above the head.

of the subject. Learning them by heart will help in the avoidance of easy mistakes such as cutting someone off from the neck or knees. Generally, framing a person in a way that cuts them off in the joints is not recommended since the end result often seems a bit violent.

Secondly, it is good to learn the two most common styles of composition: the central composition and the golden ratio. The direction of gaze or movement should be taken

into consideration in the photos. If a person is facing or a car is approaching the camera directly, central composition is a good choice. Instead, when a person being photographed is not facing straight at the camera but towards the left, or the car is speeding from left to right, they should generally be placed in the image area so that there is more space left towards the direction of gaze or movement. If the framing is done in the opposite



**5. A medium long shot (MLS)** portrays a person from mid-thigh up. No excess space is left above the head and the arms are at the sides, visible in their entirety.



**6. A long shot (LS)** shows a person in full. No excess space is left above the head or below the feet.



**7. A very long shot (VLS)** portrays a person in their surroundings. There is a lot of room both above and below.



**8. An extreme long shot (ELS)** is as wide a shot as possible. It shows the whole picture with the surroundings and details are not discernible.

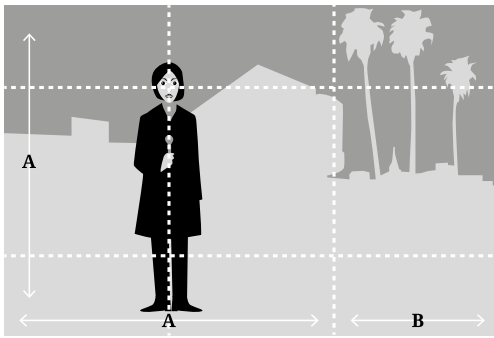

The golden ratio is based on mathematical relationships. It means dividing the image area into approximately three sections in a horizontal direction and three sections in a vertical direction, so that the relationship of the parts is 2:3. When recomposing the image, the important items of the photo are placed at the points of intersection. Central composition means placing the items at the points of intersection in the middle of the image area. This composition is particularly effective when placing a target that is facing the camera directly.

way, this leaves very little space for the direction of the gaze or movement, emphasizes the “unknown” outside the framing, and creates a feeling of anxiety, tightness or being trapped in the corner.

The three most commonly used perspectives are the normal perspective, bird’s eye view and worm’s eye view. In normal perspective, the subject is photographed at eye level. When taking neutral photos or video

of people, the photographer should always choose this perspective. In bird’s eye view, the subject is photographed from the top downwards. This perspective gives the impression of the subject being weak and small. In worm’s eye view, the subject is being photographed from the bottom up. This gives the impression that the target is very large, and can also give an impression of power.



**The normal perspective**

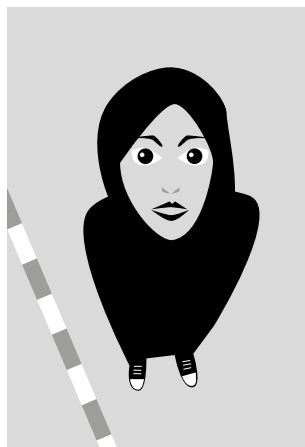

**The birds eye view**

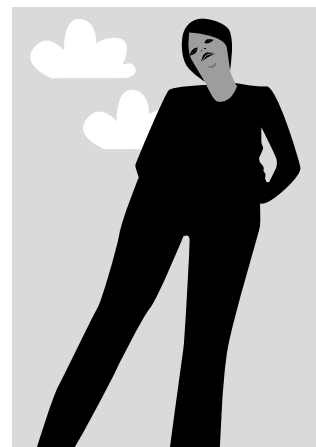

**The worms eye view**

## How far can your camera see?

For a beginner, it is important to be aware of the different types of objective lenses. There are three fundamental categories: normal, telephoto and wide-angle.

Normal lenses have a focal length of around 50 mm. They are conventionally regarded as the workhorse of many photojournalists. 50-mm lenses give pictures correct perspective with little distortion – telephoto lenses are often used for portraits for their more pleasing effect. Normal lenses thrive in documentary and street photography.

Telephoto optics are long-focus lenses that are used to make distant subjects appear magnified. Lenses with a focal length longer than 85 mm are considered telephoto. Long-focus lenses with a large aperture opening are used to remove the subject from its background. Long lenses with a narrow angle are useful when the object of the photograph is far away. They make the feel of distance shorter in the image, but they flatten objects and make them look as if they are closer to each other on the depth axis than they really are.

Wide-angle lenses have short focal lengths. Any lens less than 35 mm focal length are

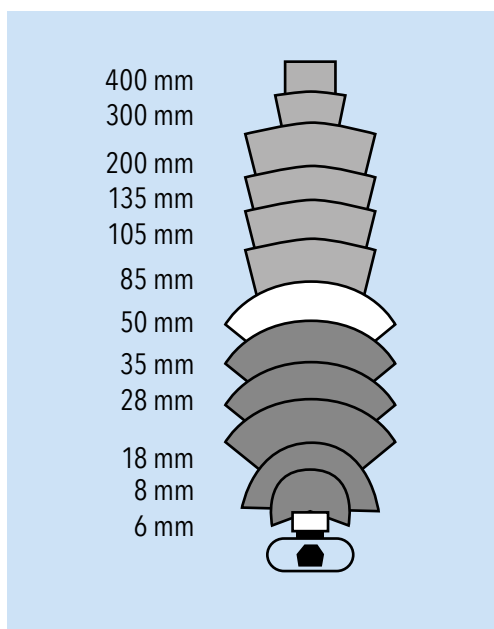

considered wide-angle. Extreme wide-angle lenses with a focal length of less than 21 mm are typically used when shooting architecture, but for a photojournalist they come in handy in crowds, small apartments, nooks and crannies. Wide-angle lenses show a larger area of the event site, but by using them the image looks more distant.



### Reflection:

Can you come up with situations, where different lens types could be used deliberately dishonestly, giving the audience a false image of the place, person or a news event?

## Meeting a subject of photography

In many countries, people are more used to photography than ever. Many carry smartphones with powerful cameras in their pockets, but some people get tense when a photojournalist or a photographer takes out their professional camera and asks them to stand in front of it.

A photographer's professional skill set includes working with the subjects of photography and directing the person being photo-



## Tips for a photographer

- A photojournalist always needs certain tools when going to shoot a story. These include the camera itself and the necessary lenses, back-up batteries and memory cards. In addition to these essentials, the camera bag should contain a flash and some spare batteries. It is good to take a shot or two at the office to make sure that the camera is equipped with a memory card and that everything is working as it should.
- Cameras are sensitive machines and sometimes they break. The photographer also has to make sure that they can take photos even if the camera breaks down during the trip itself. Nowadays, should the need arise, the photo can be taken with a smartphone.
- A photojournalist must carry note-taking equipment, to make sure the names of people who have been photographed are recorded. The journalist can interview the event's organiser while the photographer makes their rounds, so the journalist does not necessarily know where the photographer has been and whom they have met.
- There are no such things as bad conditions for taking a photograph, only lack of preparation. Before embarking on a shooting session, the photographer must prepare for both their own comfort and the forces of nature: light, wind and other natural phenomena. The photographer must also take into account what kind of event and situation they are going into in order not to attract unnecessary attention.

graphed. A few tips can help photographers taking portraits.

Firstly, it is worthwhile taking the time to get to know the subject before the shoot, as often the photographer and subject are meeting for the first time. During the shoot, the subject should be directed encouragingly and in a friendly way, so that they are able to relax – that is unless a different sort of outcome is wanted from the shoot. In addition, the person being photographed should be given the impression that you are present only for them. General politeness is also important.

Secondly, it is a good idea to ask the subject what kind of a photograph they were thinking of and whether they have prepared for it. This should be considered even if the photographer has a clear vision of what the outcome of the shoot will look like.

Thirdly, it is a good idea to carry around a pocket mirror so that the subject has the chance to check their makeup or hairdo. Reducing face shine is possible with a tissue. Small gestures like this make the person being photographed realise that the photographer wants the photo to turn out well, also from

the subject's point of view.

Fourthly, it is usually good to keep quiet of technical difficulties, if there are any. Being a photographer is in one sense a customer service profession. You should not let people see if you are in a foul mood.

## The basics of video expression

Audio-visual or “video” expression consists fundamentally of continuous photographs and the associated sound, which can be either recorded at the site or combined with the footage afterwards. This is why many guidelines that have to do with photography

also apply to videography, or “cinematography” as it is called in a film-making context. Some differences and special characteristics do exist, however. They mostly concern the nature of videography as the recording of time and movement, the simultaneous recording of sound and the combination of material, which is called editing.

In its most simple form, video footage can be shot by placing the camera on a tripod and pressing the rec button. The end-result produced is also referred to as the “static camera shot”.

Nevertheless, professional audio-visual expression requires different framings and types of shots, both close-ups and wider ones.



### Photography glossary

#### Exposure

The amount of light that reaches your camera sensor or film

#### Shutter speed

Determines the length of the cell's exposure. On slower shutter speeds, it is important to know that the image might be blurred if the photographer does not use a tripod.

#### Aperture

Determines how large the surface area is that admits light to the cell. The aperture not only affects the exposure of the photograph but also has an inverse effect on its depth of field. The larger the aperture, the narrower the depth of field.

#### White balance

A setting used in colour photography by which the white colour in the image is technically defined. White should look white in the photograph, not yellow or bluish, for example.

#### A RAW image

A lossless file format of the digital camera. Raw images are digital camera versions of the film negative. The image is saved as it is without packaging or colour correction. The adjustments can be undone and remodified with image processing software.

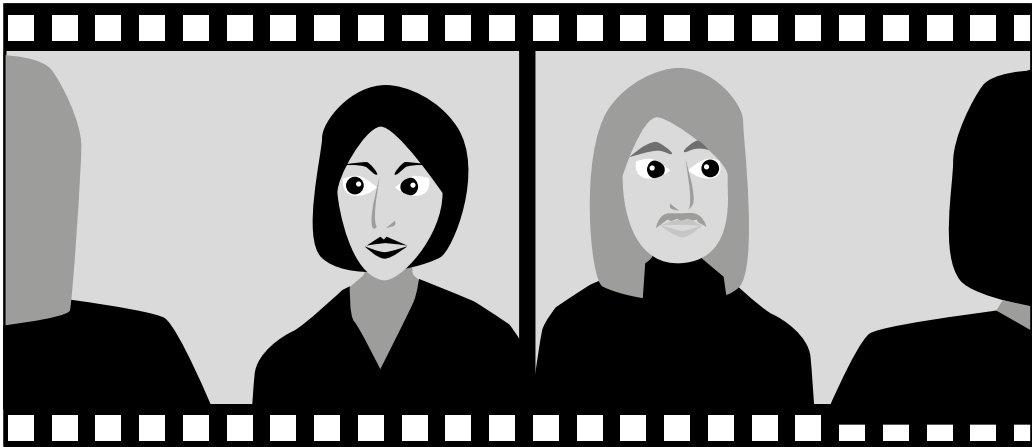

Over-the-shoulder shots are called external reverse shots.

A full-frame image shows the viewer where the event takes place. Wide shots also give the viewer an idea of how things in the imaged space relate to each other and how they move. Wide shots lack the definition to show detail and the expressions on people's faces. For these uses, more restricted framings are needed such as half-frames and close-ups. Extreme close-ups can force the viewer to focus on a detail, which is important to the narrative.

In addition, to make the footage livelier, the camera is often moved around. The most common manoeuvres of the camera have their distinct names.

Zooming refers to the technique of changing the focal length of the camera while shooting. In some cameras this is done automatically by pushing a certain zoom button. Zooming while recording is very common in amateur home videos, but it is more rarely seen in professional TV camerawork and classical cinematography. Nevertheless, zooming may be used in pseudo-documentaries and mockumentaries as well as in art

cinema, precisely because it gives the material an amateurish feel. As different lenses refract light in different ways, it is preferable to move the camera closer to the object instead of zooming or changing the lens when shifting from a wide shot to a close-up. If the lens were to be changed, the end results with two different lenses might look different in the editing phase.

Panning means the movement of the camera in which the camera remains stationary but rotates around its vertical axis, in a horizontal direction, left or right. Tilting means the vertical movement of a camera, where the camera remains stationary but rotates around its horizontal axis, upwards or downwards.

A tracking shot means that the camera moves while recording. In tracking shots, the whole apparatus moves and this is how it differs from zooming. The camera may, for example, be placed on a trolley and follow a person or a car. A common concern regarding tracking shots is how to prevent the image from shaking during the shoot. The tech-



nology of hand-held stabilising gimbals has improved drastically in the last 20 years or so, but many creative solutions such as using a skateboard, wheelchair or pushchair as a trolley can help achieve the desired outcome.

Often, multiple shots of the same scene are recorded from different perspectives to provide material for editing. The master shot means a wide shot that covers the whole scene timewise, and all of its events. In addition to the master shot, smaller framings are used to record details of what is happening. In the post-production phase, these shots can be added to break the monotony of the master shot, hence their nickname “cutaway shots”.

Reverse shots follow the discussion or other interaction between people. It is recommended to frame reverse shots similarly, considering the perspective and the scale as this portrays the subjects on a neutral and equal standing. The positions in which the people stand in the master shot should be kept constant. If the positions change or the people move around, the movement should always be shown in a wider framing, so that the viewer does not get confused. Over-the-shoulder shots are called external reverse shots. Internal reverse shots show each of the people by themselves, with just the direction of their gaze connecting them. The camera is outside the ring formed by the performer.

Reverse shot structure is a much-used practice, both in fiction and documentary cinema and in audio-visual journalism. It is easy for the editor to cut into the opposite reverse shot. This technique allows the editor to lengthen or shorten the event, remove unwanted passages and build a consistent whole from inconsistent shots, while retaining the illusion of a natural progression of events.

## The basics of editing

Editing refers to the process of creating the ultimate meaning of the shot material through 1) selecting which shots to use, 2) altering the length, speed or visual look (such as colour or aspect ratio) of the shots, 3) organising the material in a certain order and juxtaposing shots with other shots, and 4) juxtaposing the shots with layers of sound, text, motion graphics, etc.

In short, editing is a process of both cutting “out”, that is leaving some shot material unused, and cutting “in”, that is, assembling a meaningful whole of pieces of material that in themselves do not yet carry the same meaning(s) as the whole. Usually, editing succeeds shooting or otherwise acquiring the material. Nevertheless, the planning phase of editing – how we want to assemble the material and why – should be present before the camera starts rolling.

Throughout the history of filmmaking, two distinct traditions of editing have evolved: continuity editing and montage.

Continuity editing is a common style in both television and film narration. It aims to establish a time continuum, which is as unbroken as possible in the story. The desired result looks like it simply shows things happening. The viewer can peacefully focus on the content as the events slide in and out gently and fluently across different cuts.

Continuity editing is the most-used editing style, especially in Hollywood and Western commercial cinema, so it is also sometimes referred to as the Hollywood edit.

Continuity editing cuts that follow each other should always differ to a large enough degree in shot size and/or camera angle. When the object of the shot remains the same, cutting to only a slightly different framing makes

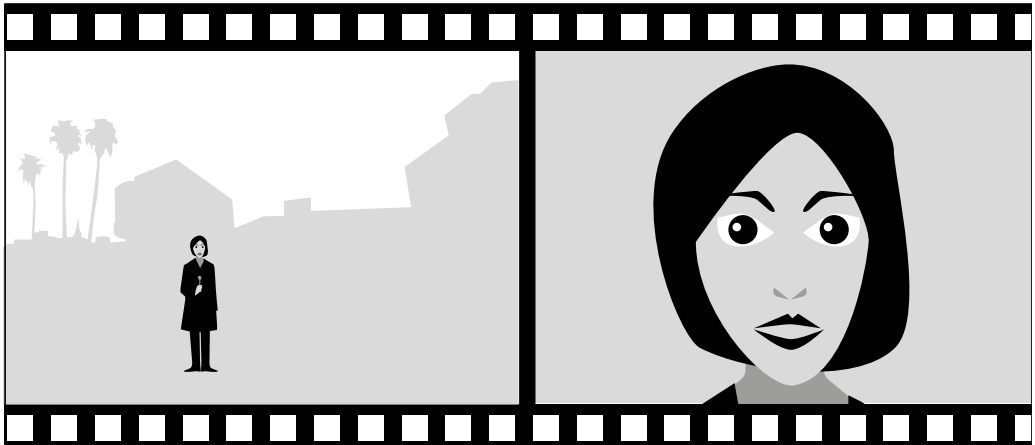

Cutting directly from extreme wide shots to close-ups might confuse the viewer.

the image seems to jump. A suitable jump in a continuity edit is two to three steps into wider or narrower framings. This same principle applies to varying the camera angle, and can be summarised as the 30-degrees rule: no edit should join two shots whose camera viewpoints are less than 30 degrees from one another. At the other extreme, it is also not a good idea to cut from very wide to close-up or the other way around because it confuses the viewer, unless confusion is the desired effect.

Additionally, in continuity editing movement should follow movement and still image still, but the type of movement may vary. It is common to cut from tilting to tilting or panning and so forth. A good way to film is to start from a static camera then move the camera from one still point to the next, keep it still for a few seconds and only then stop the recording. In the editing phase, this gives more possibilities of using the shot, as it can also be combined with static camera shots when used as a whole.

It is good to keep in mind that trajectories should be finished in the narrative.

The match-on-action technique can preserve temporal continuity where there is motion or change in the image. Match-on-action is when some action occurring before the cut is picked up by the cut left by the shot immediately following. For example, if a person is lifting a cup of coffee in order to take a sip in the first image, match-on-action would be to cut in the middle of the movement of the hand to more or less the same point of trajectory, but from another shot size or camera angle. If, however, the person is lifting the cup in the first image, it should not be cut into an image where, for example, the cup is again on the table leaving the task unfinished. This would also create a jump in the image, which continuous editing aims to avoid.

When changing the location of the camera, it is worth considering the so-called axis. This imaginary line travels through two important points close to the camera. When all shots in a scene are done from one side of the axis, the directions of people's gazes and object movements remain consistent. If movement is suddenly shown from the opposite side of the axis, the object seems to

travel in the opposite direction to what it would have done if it had been shot from the opposite side of the axis.

If a person crosses the axis, the crossing should be shown to the viewer. If the crossing is not shown, the viewer is easily confused about the orientation of the shot, producing an end result, which looks and feels illogical.

If scenes are not shot in chronological order, the continuity across shots and scenes must be taken into account. It is good to have a person at the scene, whose task is to make notes of the details of every scene, such as the locations of objects like water glasses and the clothing of the performers, in order for the whole to remain consistent. Usually this is done by the script supervisor.

If the continuity is broken at some point, the narrative is fractured, which draws the attention of the viewer to the form of the story. When this is done deliberately, it can be very effective.

Montage is an editing theory developed by the Russian film theorist Sergei Eisenstein. A montage consists of a series of images or shots, and the meaning and chain of events of the movie are born of their joint effect. Montage can be seen as the cinematic equivalent of a collage. Its main premise is that bringing two or several images together through the means of editing creates meaning that is not found in any of the used images alone.

The cinematic experiments of Eisenstein's contemporary Lev Kuleshov illustrate this. Kuleshov did experiments in which he researched the way people constructed stories and wholes of the consecutive shots they saw on the silver screen. In his best-known example, the same expression on a male actor's face is interpreted very differently when it is juxtaposed with a plate of food, a child lying in a casket or a female actress.

In addition to Eisenstein and Kuleshov, the theory of montage was developed further by Dziga Vertov, Esfir Shub and Vsevolod Pudovkin, most prominently in the Soviet Union in the 1920s and 1930s. The techniques of montage are used widely in art cinema and video art, but also in music videos and commercials.

## Audio narration as a part of video expression

Audio narration consists of speech, effects, music or silence. Elements of audio narration can play simultaneously, alternately or be synchronised to each other or the footage.

Sounds have a significant but often inconspicuous effect on the interpretation of an audio-visual story – and complete silence is hardly the least effective means of expression. Sounds affect not only the interpretation of the footage but also the interpretation of other audio elements. Melancholy music that provides the background for speech makes people interpret the content of the speech differently than if the speech was accompanied by happy or pompous music.

Listening and hearing are two wholly dif-

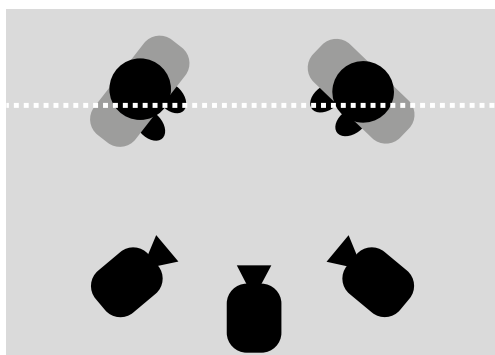

"Axis" is an imaginary line that travels through two important points close to the camera.

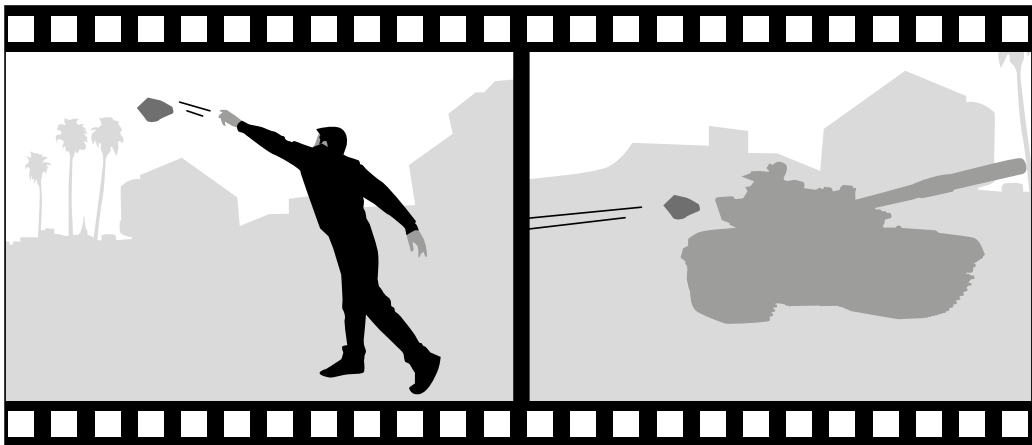

An example of an axis-mistake in video editing.

ferent things. The fact that people are surrounded by sound in their daily lives results in audio narration often escaping the viewer's attention, and the meanings it produces are left unanalysed.

Listening is a skill that can be learned. Paying attention to and analysing what you hear is the first thing to learn if you want to understand and create audio narration.

## Graphic design and illustration

Graphic design means planning the visual layout: the graphic designer's responsibility is the appearance of the message. Graphic design is an applied art form used, for example, in advertising, on websites, printed products, in electronic publications, movies, logos, package design, signboards and signposts. Elements of graphic design include colours, symbols, text, typography, shapes and pictures, materials and sometimes movement. The tasks of a graphic designer can also include illustration, photography and graphics.

A person whose main tasks deal with the layout of fliers and other things based

on the available graphic and text material is called a layout designer. Close to the occupation of a graphic designer is the art director (AD) who, in addition to graphic design, is required to have skills related to information-gathering and application and commercial thinking. The AD is in charge of the visual appearance of the publication as a whole.

The tasks of a graphic designer are numerous. They decide on the text typeface and size, heading styles, format, separation of the introductory chapters, alignment of pictures and location of the captions.

When it comes to print media, the graphic designer is also in charge of other things related to the visual layout. They choose the paper quality, sheet size, printing method, cover quality and binding.

An illustrator is specialised in demonstrating written text through images. Illustrators work in various occupations of graphic communication for different media, and sometimes make animated movies or do lettering work.

# 5

# CRITICAL READING of VISUAL JOURNALISM

In addition to journalistic and artistic thinking, photojournalists are required to understand their role as formers of worldviews and opinions. It is important for a photographer to be able to think critically when photographing, and for them to know what they are allowed to photograph. In addition to personal moral codes, many countries have laws that protect both photographers and their subjects.

## **The rights and responsibilities of a photographer**

Milieus can be divided into three categories: public, semi-public and private. In general, in democratic states, it is allowed to take photographs in public environments. Public space is something to which everyone has free access: train stations, airports, parks, streets, libraries, shopping centres and hospital lobbies.

Nevertheless, a country may legally restrict photography in certain public places such as airports due to national security concerns. Semi-public spaces include offices and factories, and photographing in them is generally forbidden, if it infringes the privacy of the subjects. Privacy laws protect private areas designated for housing, such as apartments, private yards and hotel rooms. It is forbidden to photograph a person in a place protected by privacy without their permission. Generally, at least in many countries, you also need permission from the parents to photograph a child.

When travelling, you must acquaint yourself with the conventions and laws related to photography in the target country.

Photographers, especially photojournalists, are also bound by good journalistic practice and the guidelines for a journalist. Thus, a photographer must respect human dignity and avoid focusing on characteristics such as ethnic origin, nationality, gender, sexual orientation, conviction in an inappropriate or derogatory fashion. Additionally, the photographer must not publish sensitive things related to private life without the consent of the subject or unless it has exceptional societal significance. The photographer must also be tactful when dealing with death and disease and photographing accidents and victims of crime.

The cornerstone of the business of some media brands might be the testing of the limits of good journalistic practice. It is important to ensure that the employer or customer carries the responsibility for the published photos. Ultimately, however, most ethical responsibility lies with the photographer. Only they know what the camera memory card contains, and they decide what is handed over to the news desk.

## Probative value and photographic cogency

A photograph has an effect in journalism, which is referred to by the concepts of authentication and photographic cogency.

Since its invention in early 19<sup>th</sup>-century Europe, photography has been seen to make possible the objective or even scientific storing of information and evidence. Nevertheless, cogency has been a topic of heated discussion ever since photography was invented and, with the advent of digital technology, the discussion has become even more topical. There have always been many ways to manipulate even analogue photographs but, with digital technology, manipulation is easy and almost impossible to notice. Nearly all photographers process their images one way or another. As American sociologist and photographer Lewis W. Hine remarked at the start of the 20<sup>th</sup> century: “While photographs may not lie, liars may photograph.”

Despite the fact that most people are aware of these possibilities, a photograph is still often perceived of as an objective record or evidence of an event, and it cements trust in the content of the text. After all, the photograph does “serve as evidence” to the fact that the photographer (or at least the camera) was there.

This leads to two conclusions. First, the need for self-regulation for photojournalists is as urgent as for any other type of journalist. Second, it is important for the consumers and audiences of visual or audio-visual content to remain critical towards any material we encounter in media – especially in social media.

## The ethical guidelines of photojournalism – how to retouch ethically

How to differentiate between legitimate enhancing of a photograph and manipulation that aims to distort the truth?

There is no clear answer to this. Different image processing practices are used in different fields of photography, even in different sections of the same paper. The ethics of photojournalism influence the guidelines: how realistic or truthful is the image of reality that will be presented.

The strictest authenticity requirements of all types apply to news photographs and video inserts. In practice, only technical improvement is permitted: nothing may be added nor removed from the picture.

Primarily, the use of photographs is regulated by journalists' guidelines, in addition to which media houses might have their own norms. However, in many guidelines there is only a small mention of image processing, if that. As an example of Nordic guidelines, the Finnish ones state that "in addition imagery or sounds must not be used in a misleading fashion", and the Swedish ones that "the documentary character of photographs must be supervised. One must ensure that photographs and images are truthful, and that they are not used in a misleading way" and that "Combination photographs or other digital image processing must not be used in a way that can mislead the reader. In the case of a combination photograph or image that has otherwise been retouched, there must be a mention of image processing". The Norwegian guidelines are quite similar to the Swedish ones, but Icelandic and Danish guidelines do not discuss image processing at all.

Adnan Hajj, a freelance photographer working for the international news agency Reuters, caused uproar in 2006 when he was caught having added a smoke cloud to his photographs of bombings in Lebanon. Reuters dismissed the photographer as a result of the controversy and, in 2007 roughly six months after the incident, compiled a comprehensive guideline package on image processing for its photographers.

The Reuters guidelines are above all crystallised in the premise that only slight framing, resizing and basic adjustments are allowed. It is not permitted to add anything to or remove anything from photographs. Harsh colour adjustments, exposure adjustment and blurring are also forbidden.

Reuters prohibits, for example:

- The adding and removal of elements
- The use of a cloning or healing tool on anything other than removing small imperfections
- The use of an airbrush and/or paintbrush
- Sharpening only part of the image
- Excessive lightening or darkening
- Excessive modification of colour tones
- Using the Auto Levels tool on Photoshop
- Blurring
- Use of the eraser tool
- Quick masks for selections, such as depth of field
- Automatic camera settings, in-camera saturation styles.

In magazines, image processing is more relaxed. In processing for a magazine, the mindset is often that things that do not permanently belong to a person such as skin problems can be removed. Sometimes portraits are improved significantly. A person may be made to appear slimmer, and wrinkles, skin

problems, cellulite, varicose veins and other “imperfections” may be removed.

One very special case in image processing is advertising photographs, which do not in practice adhere to the conventions of journalism. Every now and then, heated discussion arises on the unrealistic imagery created by advertising photographs and the beauty norms arising from them.

New techniques of image processing are not a bad thing as such. They are useful tools that speed up visual production. As a common rule, it can be said that if image processing has been used for something other than improving the image’s capability to reflect reality, it can be considered an effort to mislead the viewer.

Image processing is not, as of yet, an automation: someone in the editorial office makes the decision to process or not to process a photograph. Every now and then, it is worth thinking about these decision-making processes.

Social media has also changed photojournalists’ field of action. Another great and simultaneous change has been the fact that different cheap and light cameras have become more common. The position of social media as the fifth estate is reinforced, for example, by an image where the scene of an accident is surrounded on all sides by a plethora of smartphone cameras, which together form a whole with the power of evidence, consisting of a mass of photographs pointing in every direction. The photographs of citizens may either reinforce or question the credibility of a professional photographer’s images.

## Critical reading of visual content

Manipulation through image processing software is by no means the only factor contrary

to the power of evidence that photographs or video footage possess. All visual material can also be “processed” with lighting, exposure, framing and non-conventional framing of the subject. The photograph or video image, detached from the situation where it was captured, easily becomes a holistic representation of that situation, even though reality just outside the frame could be very different to what we see through the framing.

One way that visual journalism can drastically affect people’s worldviews is when repeated, recycled or stereotypical imagery starts to represent reality to its audience. This is especially a risk when tackling foreign news or news about topics that are very distant from their audience’s everyday life. If, for example, we repeatedly encounter in the media images or footage which portrays African guerrilla groups armed with Kalashnikovs conquering villages, our impression of the whole continent may be that it is war-like. This might then have very negative consequences, such as an increase in racism and xenophobia and a decrease in willingness to help charitably. To say the least, stereotypical images on the news narrow people’s worldviews.

Numerous other examples could also be named here. For example, lighting that creates a strong contrast may create a menacing atmosphere. Repeated unrepresentative photographs of politicians have an effect on their public image. A few members of the audience at a concert may be squeezed into a tight frame to create an image of an arena that is packed with enthusiastic fans, resulting in a very different interpretation of the performing band’s success to that which a wider framing shot of all the empty spaces in the arena might give.

The squeezing of masses of people is a continuous feature in media, even though



it might be difficult to prove afterwards. For example, photography from riots and demonstrations often works this way. Even if in reality the riot were very local and, just 50 meters away, people were calmly going about their daily business, the photographs may give the impression of a state of emergency gripping the whole city. These kind of framing choices are of course understandable since the aim of a news photo is to portray the topic of news, not the whole city. It is however also a question of mindful choices made by the photographer that can have effect on the interpretation of the event. Do they choose a telephoto lens to squeeze in and focus on the rioters, or a wide angle to reveal the surroundings and true scale of the riot?

With framing, subjects can be detached from their environment. The most famous example of the framing of a photograph is newspaper photographer Kevin Carter's 1994 photograph of a starving toddler in the Sudan famine, stalked by a vulture. The photograph, which won the Pulitzer Prize, caused a massive debate about the responsibility of a photographer. The photograph was read as the final truth about the situation, and enraged citizens commanded the photographer to say why he did not help the child, but stalked the child like another vulture, this time with a camera.

The story goes, however, that the photograph was in fact the result of framing choices. The vulture was in fact about 10 meters from the child and only seemed to be much nearer due to use of telephoto optics that flattened the depth of the image. The story also goes that the mother of the child walked in front of the child and there were other people around as well. Whether or not this description of the situation is accurate, the bottom line is this: knowledge about surroundings

and events happening before and after a single frame or even a video clip is never told by the end product, to the benefit or harm of the photographer.

The event took a tragic turn when Carter, who never fully recovered from the traumatic events he had witnessed as a war photographer, committed suicide in 1995.

It is good to return to this photo when thinking about the mission of a photographer as a journalist. Is it truly so that a photograph that shocked the world and made many people politically aware of the situation should not have been taken at all, so that the hands of the photographer would have been free to help one child?

# 6

# The DIGITAL REVOLUTION and SOCIAL MEDIA

**J**ournalism, and society as a whole, have undergone a revolution since ever wider access to the internet began to spread in the 1990s. One of the most important changes this has enabled is the invention of social media. Since the creation of Facebook in 2004, if not earlier, social media has in a comparatively short time become an integral part of people's daily life, both during work and leisure time.

Social media is a term under which various and very different online services can be grouped. All in all, it is difficult to precisely

define it. These services do, however, have many things in common.

First of all, the core characteristic of social media is that it is social: it is based on interaction between users and user-generated content. The users of social media can be individuals, communities, corporations and organisations. Users can communicate with each other, share content, comment on things published by each other, form groups or filter for specific content. In addition to communicating with actual friends, networking and exchanging ideas is perhaps increasingly happening between previously otherwise un-

known people. The possibilities are virtually endless.

Another characteristic that social media services have in common can be found in media technology that is used to spread the messages, images, videos and other content from one user to another. In practice, this technological foundation is the internet, but the web itself is not enough. Like other online services, social media requires a device by which the service can be accessed.

During the dawn of the internet era, the electronic communications network was most often connected via desktop computers. They were impractical or impossible to move around without losing connectivity to the network. The computer was most likely situated at work or at school, sometimes at home. This meant that its use was limited. The work computer could only be used during working hours and computer use at home was, at least in the early age of internet, mostly limited by its connection to the television or telephone line.

One of the most important aspects of the revolutionary penetration of social media channels has been the development of wireless network technology. Mobile technology in particular has totally freed social media and other online services from the restrictions of space and time. A smartphone is relatively inconspicuous, easy to use and portable. The phone is wherever its user is: at home, at a party, on vacation or at an event. The experiences and phenomena people go through transform these days almost instantly into social media content. The oft-heard phrase since 2010 “if it isn’t on social media, it didn’t happen”, has become strikingly true.

Thus, using social media platforms and tools, our everyday experiences, thoughts,

videos, news, photographs and their associated comments can reach an ever-larger audience at the single push of a button. To be exact, according to statistics published by the London School of Economics and Political Science in January 2019, of the total human population of 7,511 billion people, some 3,811 billion people (51 %) have access to the internet and 2,895 billion people (39 %) use social media actively. In addition, its use seems to be increasing despite occasional criticism. With its 1.2 billion users in 2019, Facebook, which launched in 2004, still holds its place as the most used social media channel in history.

To sum up, social media has made it possible for at least some bloggers, YouTubers or other active content producers to reach out to audiences that are much bigger and globally wider spread than most traditional news channels. This raises many questions not only of responsibility but also of the urgency for critical media literacy skills.



Kevin Carter 1993.

## Social media platforms and tools

The multiplicity of social media is more easily perceived through different classifications. The classification can be based on the sense of community, content or linkage to time or place. Social media is after all a field, which is in a state of constant change. New software platforms, services and applications are continuously being developed, old ones are being transformed or replaced by new competing options. Even though classifications are often simplified and overlapping, social media can, for example, be divided into different categories based on the ways it is used:

**1. Social networks.** A service is called a social network when the users have the chance to reach other people through it, to network and form different groups and to share content with other users or groups of users. Users can be related through kinship, friendship, hobbies, work or, for example, through a religious or political conviction. Shared content may incorporate sound, text, images, videos, links, different files or the combination of all of these. Users have the chance to interact with each other, to form groups with one another, to publish content and to share it further and comment on it. Services like this include Facebook, Twitter, Pinterest, YouTube and Instagram.

Some social networks have been born of regional needs. In China, a popular service like this is called Douban, in South-Korea Cyworld, in Japan Mixi, and so on.

**2. Instant messaging services.** Instant messaging services like WhatsApp, Signal, Facebook Messenger, Telegram and WeChat are among the most popular social networking platforms between users, and have become a very serious challenge to cel-

lular operators worldwide due to the free use of these applications and platforms.

**3. Bookmark sites.** With these services the user can save and organise any links leading to online services or pages. Links and link collections can be organised through different index words or classes. The user can share their link collections with others. StumbleUpon is one of the most popular bookmark services.

**4. Social news sites.** With the help of these services, users send, read and share links to actual news sites, which contain the news and articles. Users of the service vote either for or against a news article. News will be displayed on the page after this based on how popular it is. Reddit is an example of this kind of service.

**5. Media sharing services.** With these services, users can share media content with each other. Media can be images, sound or video, for example. As in the case of social networks, these services often provide the chance to create an individualised user profile, under which the user compiles the content to be shared. Other users can rate and comment on shared content. Services like this include Vimeo, YouTube, TikTok and Flickr.

**6. Forums.** Forums give users the chance to discuss a certain topic with one another within the website. Content mainly consists of text, but a forum can in principle include anything: images, sound, links and so on. Very often content sent to a forum is overseen by an administrator. Supervision often concentrates mainly on the filtering of offensive or unlawful content.

**7. Blogs and vlogs.** The most common definition for a blog is an online diary that can be kept by one or more writers. Thus, blogs often consist of blog entries published in chronological order. These entries fea-

ture topics that are either linked closely to the writer's life or attract their interest. They can cover pretty much anything from fashion to health issues and from pets to foreign politics. A blog can feature text and/or images, videos or for instance, solely cartoons. A blog in the video format is called a vlog.

In fact, there are such an unlimited number of themes and styles of writing in blogosphere, that it is becoming increasingly difficult to define the term. A blog has pretty much become a generic term describing pretty much any type of user-generated publishing. Some blogs cover the news in more depth and even more reliably than many professional news desks. Blogs have offered people a chance slowly and analytically to write about topics that are no longer covered in the traditional media. Popular bloggers who cover topics in narrow, specialised fields can attract readers from all over the world.

Blogs are also written for marketing purposes by companies or influencers. The success of some bloggers has raised questions about their responsibility and financial transparency. Famous bloggers might receive notable financial benefits in the form of gifts or even direct payment in exchange for the coverage they offer a manufacturer. In principle, the ethical standards of journalism do not bind the bloggers in the same way as traditional journalists. Unlike in journalism where marketing is totally forbidden, bloggers are not always expected to be independent or impartial.

**8. Micro blogging services.** A micro blog is exactly what the name implies. Through a service like this, users publish short textual content, which can also include links to other content on the internet. The content is published, on the user's "wall" or "feed", which other users can view. Users can sub-

scribe to content published on another user's wall. These are especially used in political debates and the entertainment industry in the form of a second screen, for example with a sports or entertainment television broadcast and for event communications. The most popular micro blog platform is Twitter.

## Social media challenging traditional media

The digital revolution of media is a term that refers to the on-going change in the commercial logic of editorial offices caused by digitalisation, and perhaps especially social media. Firstly, newspapers are increasingly being read online, which is why the circulation of the printed papers and thus the amount of money collected through print advertising has been decreasing rapidly since the first years of the new millennium. The web versions of news channels and magazines also need to compete with the wide variety of blogs and other free sources of information available to anyone equipped with internet access. Audiences of the television networks are splintering as streaming services take over.

In many media corporations, decreases in revenues have led into cutbacks in the work force. The remaining reporters are often forced to produce multichannel news coverage with smaller resources. At the same time, content produced by people other than professional journalists such as blogs etc. is challenging the role of media corporations as the channel for acquiring information and setting the agendas for public discussion. The professional news media is increasingly picking news topics from trending social media discussions and not the other way around. This means that the role of citizen journalists,



## Social media glossary

### Bot account

A bot is an agent that communicates on social media, for example on Twitter. Bot accounts are often automatic accounts that do not have a real user behind them. Bot accounts are used to influence attitudes or thoughts through social media and, for example, to reinforce a particular political message. They can also distribute spam or malware.

### Creative Commons (CC)

A public copyright licence that gives you the ability to use and share otherwise copyrighted material such as photos for free. Creative Commons licensed photos can have restrictions on whether an image could be used commercially, whether it can be modified, and what kind of attribution is required.

### Crowdfunding

In crowdfunding a company or a person can fund their project or product by seeking small investments from individuals, most often done through the internet at dedicated crowdfunding websites.

### Crowdsourcing

means that problem-solving is handed over to an undefined group of people, usually through an open invite published on the internet. Crowdsourcing can be utilised by companies but also for example by editorial staff.

### Cyber security and cyber warfare

Cyberwarfare is the politically motivated use of technology to attack a nation or a nation's computer and information systems, causing harm comparable to actual warfare. With cyber security, nations actively try to protect themselves from cyber-attacks.

### Embedded media

The content of digital media, like a YouTube video displayed within another piece of content, outside its native setting.

### Emojis

Emojis are Unicode-standard symbols, which can portray expressions, feelings or even images expressing, for example, leisure time, country flags and different characters. The most used ones are the smile and the thumbs up emojis and new symbols are constantly being produced by users.

### Fake news site

A fake news site publishes incorrect content designed to provoke and mislead readers. A fake news site often resembles well-known and established media, making it even harder for readers to recognise untrustworthy sources. Fake news can go viral on Facebook, where users often share content without clicking on or checking the source.

### Graphics Interchange Format file (GIF)

A file format that supports both static and animated images. Gifs allow the presentation of short "video clips" in a condensed image format.

### Hashtag (#)

A content identifier used in social media services such as Twitter and Instagram. By marking a central word with a hashtag, it is possible to locate messages as a part of the related online conversations. This serves to increase follow up, classification and to locate those who share common interests and concerns. The hashtag is also an effective tool in shining the spotlight on a particular issue, be it political, economic, social or sport-related with the aim of mobilising the public towards the issue at hand. Examples of popular hashtags include #metoo and #climatechange.

### Meme

A meme is a popular and quickly spreading content on the internet. A meme can be a funny image, video or hashtag. The original meaning of the word meme is a cultural and communicational copy: an idea, style or way of use that spreads in culture from one person to another.

### Onion network

In an onion network, special encryption is used to anonymise messages so that they cannot be traced to their senders. The anonymity can be broken but it is time- and resource-consuming, so the onion network is used by those who use the internet for illegal activities or who dislike the idea of constant surveillance in principle. Onion routers are easy to use even through a special application on a phone.

### Podcast

Podcast A podcast is a digitally shared voice-series with episodes that can either be downloaded or streamed directly from the source. Podcasts, like blogs, usually have a common theme and can be produced as a monologue or have several voice actors. Podcasts can sometimes be produced by large media companies but many popular podcasts are produced by private individuals.

### Retweet

A tweet that is re-shared to the followers of another user's Twitter account is called a retweet. It is part of Twitter etiquette to give credit to others and not just copy someone else's ideas. The retweet does this since it appears in your timeline with the author's name and avatar allowing your followers to easily retweet or like the original Tweet.

### Spam

Unnecessary and repetitive social media content that clogs up the feeds of social media users.

### Tag or "@"

A keyword added to a social media post with the original purpose of categorising related content. A tag can also refer to the act of tagging someone in a post, which creates a link to their social media profile and associates them with the content.

### **Troll**

Traditionally, an internet troll is a person whose main purpose is to provoke, irritate and bully others online. Recently, the term has taken on a new meaning, as groups of 'trolls' are organised and paid for publishing anonymous, political content, which is used for the purposes of propaganda and information warfare.

### **Tweet**

A microblog post in Twitter. It consists of a maximum of 280 characters and may include text, photos, links, hash-tags and tags.

### **URL (Uniform Resource Locator)**

Locates a page or other resource on the World Wide Web.

### **User-generated content (UGC)**

Content that has been created and published online by the users of a social or collaboration platform, typically for non-commercial purposes and it is one of the defining characteristics of social media.

### **Viral phenomenon**

An internet phenomenon in which some content spreads at great speed and sometimes achieves great popularity. The word viral originally refers to viruses: something that spreads virally, like a virus.

regular adults, teenagers, peace activists or, in extreme cases, terrorists as agenda-setters is growing. Also, especially in popular culture but also in politics, the starting point for a news piece is often an Instagram, Facebook or blog post created by the sources and objects of the news themselves.

In addition, professional reporters who control the production of messages are being partly replaced as the gatekeepers of information by the digital media corporations, such as Google and Facebook. Instead of controlling the message production, these online gatekeepers are controlling what the audience are exposed to by manipulating the order of the search results and algorithmic picking of content to feed.

There are two types of visions for the future of journalism.

The positive vision of these two involves an idea of developing the already diverse media publicity into something that is more strongly based on dialogue and interaction. Rather than having a passive group of recipients, media will be greeted by an active audience. In this way, the digital era is changing the traditional concept of the professional identity of reporters. Discussions taking place on social media can at their best promote democracy, enhance the supervision of journalistic work, support multivocality and offer access to information and arenas of discussion, even to those living on the periphery.

According to the negative vision, in the future traditional media will not be democratised, its news production will not spread out, and citizens will not be better informed. The ownership of the media, by contrast, will become concentrated, resources decreased, products standardised and made more entertainment-focused and their quality impaired. Hoping to gain the most clicks, populists and





## Protection of privacy and social media

An increasingly large part of our communications and correspondence goes through electronic “mail services”. When we hand in our correspondence at the postal service, we trust that the clerk delivers our letter unopened to the receiver. One might assume that our e-mail and social media correspondence should be similarly private between the sender and the receiver but, due to disclosures made by several informers, we know that this is not the case.

Perhaps the most important informer of the 2010s’ was Edward Snowden. In 2013 Snowden, who had worked for a subcontractor of NSA, leaked documents to the press, which revealed the widespread espionage that the United States intelligence service was practising. In the name of national security, information had been gathered about large groups of people both in the United States and elsewhere in the world. The majority of the people were not under suspicion of any kind of crime. The documents that Snowden leaked showed that NSA used

surveillance software with the help of its “partnerships”, large US-based telecommunications and internet corporations. Some of these partnerships had been already formed decades ago. Others were more recently established, after the events of 9/11, during the war against terrorism. The PRISM software, used for espionage, is the largest ever espionage system that has come to light in the US. Of current common services, some information had been provided by Google, Facebook, Skype, Hotmail, Yahoo! and YouTube, among others. The cloud storage service Dropbox was joining the PRISM programme at the time the news was leaked. The group is missing Twitter, at least for the moment. The leak started a wide discussion of the digital rights of citizens and the protection of privacy on the internet.

**Reflection:** What kinds of ways to improve protection of privacy are there in the international world?

shocking news will replace in-depth and slow analyses. News, and in particular news headlines, will become more sensational. Under commercial pressure and the concentration of ownership, the autonomy of journalists will decrease.

This is not the first time, however, that the media will have undergone a change. Every time a new form of media becomes pop-

ular, it challenges the way the existing media corporations work and earn their revenues.

## Revenue logic of social media

The channels and services of social media that are free to the user generate income by selling advertising space and/or providing user



## Critical activism glossary

### Clicktivism

The Oxford Dictionary defines the term clicktivism simply as “the use of social media and other online methods to promote a cause.” Social media enables a fast and easy way to support a cause, value or campaign.

### Slacktivism

is a combination of the words ‘slacker’ and ‘activism’ and means lazy activism. The word is a derogative term for “feel good” activism. What is typical for slacktivism is that it only has minor practical implications as its purpose is solely to make a person feel good about her-/himself as an active citizen. An example of Slacktivism can include liking a campaign photo on Facebook or clicking “attend” on a campaign event with no intention of physically attending.

### Hacktivism

combines activism and hacking, meaning someone breaks into a computer or a network to gain confidential data or information. Hacktivism is usually related to an at least seemingly moral cause, and has been used in revealing malpractice and in online boycotts.

### Data activism

Data activists utilise, collect and combine often online-based open source data to draw attention to issues overlooked by those in power. Data activism has the potential to highlight and alleviate structures of inequality but is sometimes problematised due to the lack of expertise associated with it. At times, open data combined and analysed by non-professionals can end up being skewed.

### Brandivism

During the era of digital advocacy, corporations are increasingly interested in activism. Some companies are keen on actually advancing social change, but some have merely begun to take note of the brand value that social consciousness offers. This means that businesses in several fields are now actively promoting eco-friendliness, sustainability and equality to name but a few trends. Consumers’ reactions to brandivism are divided: some think it is good that corporations have become more aware and ‘are doing their share’, while others criticise these actions for being profit-oriented ‘greenwashing’ or ‘pinkwashing’.

data to advertisers. This means that the social media service customer is not the user but the advertiser.

For example, when a person creates a profile on Facebook, they simultaneously give the corporation the right to view and handle their personal information and information on user behaviour, such as actions, locations and likes. It is a question of exchange, where

the user provides information about themselves in exchange for the use of a free-of-charge service. Channels like Facebook are free, because they sell to advertisers, in an indirect way, a huge amount of data, which they gather from the users and which enables very powerful tools for advertisement targeting.

As another example, the Google search engine shows the user personalised adver-

### Greenwashing

Businesses have been criticised for 'greenwashing' their otherwise non-climate-friendly operations by marketing environmental friendliness and sustainability. The clothing giant H&M, for example, faced a backlash after launching a 'conscious clothing collection'. Critics deemed the campaign as deceptive for consumers, as the clothing brand's inherent business idea is non-ecological fast fashion.

### Pinkwashing

The concept pinkwashing is similar to greenwashing, but instead of sustainability, the promoted issue is LGBTIQ rights. In the hope of appearing as progressive, an increasing number of brands are taking part in equality events like Pride and promoting its products. Pinkwashing is not only done by brands, as on well-known example of pinkwashing is Israel. According to political analyses, the efforts at making the country look appealing and advanced are attempts to distract Western countries' and tourists' attention from the Israeli-Palestinian conflict.

tisements based on past searches by the user.

From time to time, the data collection methods of large corporations become the topic of debate. Users do, however, hand over their information and content for the use of the social media corporation. This handover is a part of the terms and conditions and cannot be relinquished afterwards by campaigns or boycotts.

Still, every once in a while, it is worth discussing why we hand over our personal information to these services. Would it be possible, for example, to limit the right of the corporations to forward private information to other organisations through legislation?

## Activism and campaigning on social media

Activism on the internet has a long history. Before the era of social media, the medium for civic activism and campaigning was by email and on various online forums.

In 2020, campaigning and activism is easier than in the 1990s and has become part of our daily lives. Social media has also become a way to get organised. However, activism taking place on social media also has a flip side. The information overload that people face every day is so vast and diverse that individual campaigns often get lost in the abundance.

Digital activism has given birth to fairly negative-sounding concepts like slacktivism, clicktivism and hacktivism. Even though these terms are dismissive words, the phenomena behind them are just about to reach their full potential. Digital media is increasingly being used to support a change within society. For example, in organising events during the Arab spring, social media already played a major role. As another example, the #metoo campaign that started in 2017 has to this day resulted in much debate about and even some legal actions against gender-based discrimination and violence globally. This campaign gained significant momentum when celebrities joined it.

To help in the understanding of this, Amnesty International has published an activism guide, which anyone can use to start a cam-

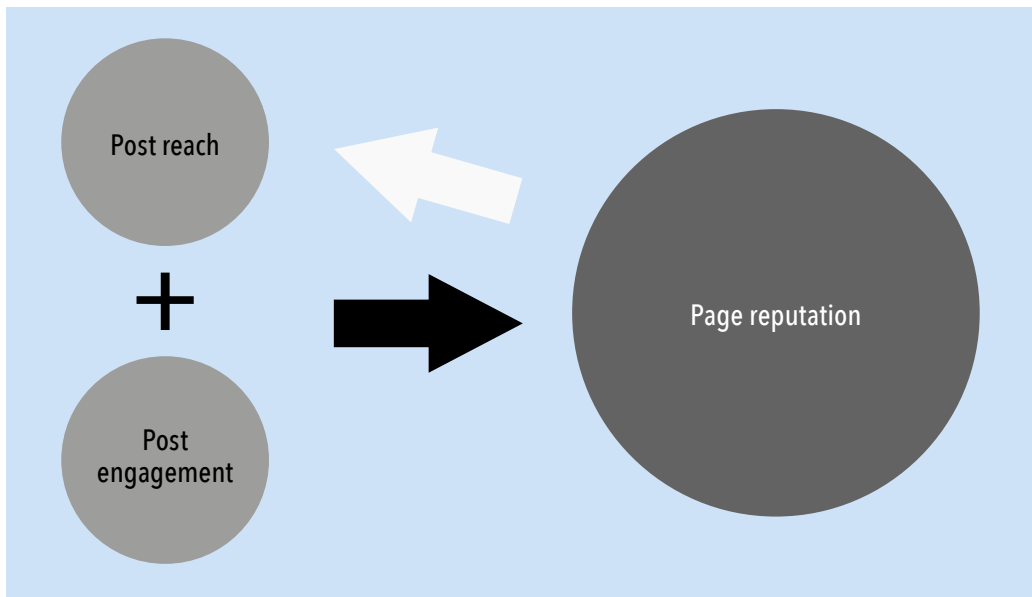

A simplified description of Facebook's algorithm. The same principle of good page reputation leading to more visibility also applies to Google Search Engines and many more social media channels.

paigned to support human rights and increase awareness of human rights violations. There are also websites offering tools to create public petitions, which can be initiated by anyone.

Activism in itself can of course be bad or good in nature. Hate speech campaigns, hacking and spreading private information may also be classed as web or social media activism.

### **How to use social media as a business or a community?**

The major difference between marketing on traditional media and marketing on social media is the speed. Electronic arenas offer a possibility for peer assessment and feedback that can spread surprisingly fast.

Thus, because social media is by nature social and interactive, it cannot be controlled the way that traditional printed media is.

Places where one can leave comments also make it possible to give negative feedback, and some content might also be shared with an intention of ridiculing someone. Also, an increasing amount of customer feedback comes via different social media channels and as such is public. Nevertheless, as there are always trolls and other internet bullies present on the internet, one must not be frightened by a small amount of negative feedback.

What is important with negative feedback is recognising the difference between trolling and actual negative feedback. A troll usually poses less threat to the image of the organisation, while an authentic, negative customer testimonial might prove very harmful to the brand and should usually be replied to. When the complaint is dealt with quickly and efficiently, there is potential to turn a disappointed customer into a pleased one.

On social media, companies and communities are expected to reply to a customer's

question on the same day. For this reason, it is necessary to estimate the sufficiency of communication resources beforehand. There is no point in creating presence on social media if you do not plan to participate. Just “going there” or “being there” is not enough.

These aspects are not, however, arguments against acting on social media, quite the contrary. By producing content themselves, organisations can control at least a part of their coverage on the internet. Popular blogs will feature higher on search results than individual criticism. Social media also makes

it possible to target communication effectively to carefully narrowed target groups. It also makes it easier to follow the coverage of a company or community.

Clear instructions for commenting and clearly formed justifications for removing or leaving certain comments unpublished will prevent speculation about censorship. The act of moderating is a way of controlling commenting on your own electronic networks, but it cannot prevent others from sharing your content and commenting elsewhere.



## A successful advocacy campaign

Civic activism and advocacy campaigns have the potential to make vast social changes when a significant number of people engage. In addition to support, a successful global campaign often calls for wide social and traditional media coverage, and allies in the midst of politicians, celebrities or influencers. World-wide public marches and protests are also beneficial in terms of increasing visibility and getting the media to engage.

A well-known example of a successful advocacy campaign is the school strike for climate. The wider movement was initiated in 2018 by Greta Thunberg, a then 15-year-old Swedish activist, who began to strike for climate on the steps of the Parliament House of Sweden on Fridays. She refused to go to school before the policymakers of the world started taking serious initiative to fight the climate change. The movement gained support quickly, as students around

the world started protesting for climate action. #Fridaysforfuture-hashtags and photos spread, millions of protesters took to the streets and Greta Thunberg gave speeches at the World Economic Forum, U.S. Congress and United Nations' Climate Action Summit.

While the school strike for climate has gained significant global attention, the question remains – what next? The 2019 IPCC report estimates that the global temperature rise must remain below 1.5 °C above pre-industrial temperatures to prevent a climate catastrophe, while current climate commitments will result in the temperature rising by over 3 °C. The school strike for climate has been a successful advocacy movement, but much remains to be done.

**Reflection:** Can you come up with more examples of successful internet campaigns?

# 7

# CRITICAL READING *of* SOCIAL MEDIA

**T**he starting point of journalism is to be objective, critical, autonomous and progressive. Professional journalism is controlled by national and international laws, and the self-regulation and ethics of journalists.

Through social media, people are daily exposed to a massive amount of media messages, such as news, images and videos. Considering this huge media reach and the possibilities of available modern technologies, it must be recognised that not all media content is journalism, self-regulated or even telling

the truth. There are also rumours and fabricated information just like in face-to-face interaction. Neither journalists nor citizens should trust any content absolutely, regardless of the source.

## **Online conversations tend to be polarised**

What kind of rules apply online? Can almost anything be said without anyone being held accountable for it?

Online discussion refers to any discussion held online. It can typically happen in internet conversation forums divided into specific topics, in the form of comments under posts or within a certain hashtag or by replying to people with tags, for example on Twitter. News shares and posts on social media provoke online conversations, which sometimes get more publicity than the original posts or news articles.

While not everyone participates in online discussions, those who do are often loud and use rich expression. In general, then, online conversation can be characterised as polarised, emotional and engaging. Individuals participating often form their opinions fast and present arguments with no fact-checking. In addition, one of the downsides of online conversation is that especially when the topic is political or controversial, it includes attacks on individuals, or so-called ad hominem argumentation.

Social media commentators, of course, are not as a rule restricted by any guidelines, nor do online discussion and feedback forums have journalistic or any other kind of filtering. When adding to this the fact that sometimes people even hide their identity under pseudonyms, it is easy to see why the world of online discussion sometimes seems like the Wild West.

From time to time, threatening and bullying messages are brought to light. Despite this, many willingly acknowledge the idea of freedom of speech and even rely on it loudly when making controversial comments online.

Current research concludes that the choice of social media channels affects the flow of information. For example, a study by Mark Boukes (2019) suggests that the use of Twitter as a news source provides access to a wider range of topics and viewpoints, whereas the use

of Facebook offers a polarised view: a one-sided selection of news through their network.

This creates filter-bubbles where people get a falsified idea of the truth through individualised search results and following conversations that seem suitable to their own opinions. Some communities of different channels and platforms, such as Facebook groups, set their own guidelines and limits to discussion. For a new member, these can come as a surprise. The community may, for example, use a particular language and communication style that can be tricky to learn when entering the discussion.

## What is allowed in netiquette?

Even though it is practically impossible to make sure that everyone is playing by the common rules, it is good to keep in mind what kinds of issues based on legislation and ethics should be taken into consideration.

The basic rule of internet communication is that the same rules apply as elsewhere. For example, stealing and harming someone's work, identity or possessions are as illegal online as elsewhere.

One can also be held accountable for violating copyrights online as well as offline. Many services online such as YouTube are international. Violating copyrights will lead to deleting the material at the very least but, at worst, can lead to criminal charges.

On one hand, the same laws concerning, for example, defamation and inciting ethnic or racial hatred apply online and this often seems to be forgotten in midst of polarised online conversations. On the other hand, freedom of speech, manifested for example in laws and international treaties, protect one's right to express oneself and one's opinions.

In addition to legislation, a netiquette should include many ethical questions. First of all, once material is uploaded to the internet, it will likely stay there forever. Given this, when publishing information or pictures that concern others, one must be extra careful. Even family members and friends are protected by the laws protecting privacy and against defamation. What is even harder is to set limits on rights to publish photos of one's own children. At what age does the decision on publishing photos online move from the parents to the children themselves?

Along with the growing rates of internet access penetration, it is also only natural that some of the bullying has moved from classrooms and workplaces to the internet. Cyberbullying can include messages that are mocking or threatening by nature, which can also be published on the 'wall' of the person who is being bullied; spreading rumours or personal information; manipulating and distributing photos; using someone's name without authorization; barring someone's access to a group or a discussion; establishing groups with the intention of disparagement; tricking people into giving their passwords; slander on a blog or other publication.

Trolling is also a form of cyberbullying. A troll is a person who intentionally misleads discussions online, such as on forums or in comment threads. The main intention of a troll is to annoy people, cause conflicts and provoke people online. This might happen in the form of slandering or leaving inappropriate comments, or just by writing unnecessary messages so that, in the end, following rational discussion comes well-nigh impossible. Because trolls seek to provoke an emotional response, the best way of dealing with them is to ignore them completely. There's no point in debating with a troll.



## Tips for social media friendships

- Do not tell people on social media what you cannot tell them face to face in the presence of others.
- Do not write on social media what may embarrass you if it was read by your family member, boss or idol.
- Always remember to deal with the issue presented and not the person who presented it. Personalising issues does not benefit anyone.
- Remember that communicating emotions is sometimes tricky through short postings. The reader sometimes cannot tell if, when writing them, you were angry, critical or cynical and they may misunderstand you. The use of sarcasm in particular should be carefully considered.

Part of the etiquette also includes acknowledging that clicking is power. Nearly all media websites count the number of visitors by counting clicks. In addition, the power of clicks is enforced by digital and social media algorithms as clicks make content spread.



Many positive things have been achieved by liking and sharing. However, it is good to remember that a click also reinforces negative phenomena. A click is basically anonymous: it does not tell whether you liked the content or not. It only tells the hard fact that a certain amount of people became interested enough to click it. For this reason, the only way of preventing unpleasant, inappropriate or bullying content from being shared and spread online is to resist your own desire and curiosity to click on it, and simply leave it be.

For example, videos shared online by extremist militant group Isis generated this type of discussion. In some of its most disturbing videos, Isis killed its hostages. The sole purpose of these brutal videos was to cause fear, terror and utter shock and to recruit more people to support their violent ideology. The more people clicked on these videos, the more effective their campaigning was.

## Fake news sites flourish on the dark side of the internet

When discussing the dark side of the internet, it can be divided into the black and the grey area. The black area includes illegal activities on the internet such as hacking, fraud and other criminal activity. The grey area is not illegal, but can be considered immoral by, for example, spreading false information.

Counter media (or “alternative media”; “misinformation media”) is a term that describes the kind of media, usually operating on the internet, which publishes information that is not in line with the so-called “mainstream media” or “established media”.

Counter media often borrows the style and format of established journalism and, in doing so, also shares the credibility jour-

nalism enjoys in the society - for some readers at least.

Nevertheless, counter media tends to publish very biased information whose reliability may be questionable, and the responsibility for fact-checking and source-criticism is



### Dark side glossary

#### Misinformation

Information that is false but not created with the intention of causing harm

#### Mal-information

Information that is based on reality, and used to inflict harm on a person, social group, organisation or country.

#### Disinformation

Information that is false and deliberately created to harm a person, social group, organisation or country

Source: UNESCO. [en.unesco.org/fight-fakenews](http://en.unesco.org/fight-fakenews)

**Reflection:** Do you think there should be some licences or permits to start a newspaper? What benefits or disadvantages would this have?

transferred to the readers themselves. Counter media does not follow the journalist's guidelines.

Part of the popularity of counter media can be explained by the fact that the readers

can find the kind of information that the established media may refrain from publishing. This may include topical issues that the established media do not report for ethical or political reasons - and this is often what counter media activists would like us to think. People seeking this kind of content tend to search for and believe the kind of information that strengthen their own worldviews and beliefs.

The term "counter media" itself is a new one that is not yet fixed in vocabulary – the phenomenon is becoming more widespread, and commonly accepted terms to describe it are being discussed.

## Content verification can help in tackling the problem of fake news

The motives of different internet users can be different from those of journalists who produce content within specific professional and ethical guidelines. This requires other users to check and verify postings and content and the motives of their producers in order to confront fake news. Nevertheless, even a critical media-literate social media user may fall prey to misinformation.

Images, websites, false profiles or news-like content is sometimes created with the intention of benefitting through fraud. Sometimes this is made for financial gain, and sometimes to influence a campaign or an issue. Misleading information can also be unintentionally circulated by individuals, activists and organisations with good intentions, so it is crucial to maintain a critical reading mindset when consuming media, especially when the information is somehow surprising or new.

In order to avoid falling prey to misinformation, the following details must be verified:



### Tips for digital security

Some negative aspects of the internet can be easily avoided by simple mnemonics.

- **Viruses and malwares** – You must have anti-virus software and a firewall installed on the computer. If you cannot be completely sure who publishes particular software, do not install it.
- **Password protection** – A good password includes upper- and lower-case letters, numbers or characters. Do not use any of your identifiers in the passwords. Change passwords from time to time.
- Never hand out passwords, credit card information or personal information by email.
- If you come across an unbelievably great offer on the internet, such as a sudden inheritance, do not believe it.
- Take backups of all the files on your computer. For this, preferably use both an external hard drive and a cloud service.

1. **Verify the source:** Who are they, what are their motives and interests.
2. **Verify the time** the text or images were uploaded. Compare the text with the time and search for day or night in the images. Look for the season of the year and compare it with the scenes in the images. Analyse time differences.
3. **Verify the location:** Google-search images of the location and compare them with what is posted. Geographically locate every location and compare it with the image or the posting you are verifying.
4. **Verify the image:** Save it on your computer and upload it to Google Images Search. Find the origin, where and when



## Tips for verifying news, text content and users

Use sites to debunk the spread of false information, such as Snopes, and to check whether the content to be verified is available on such sites. Identify the original content and its source by searching for the same or similar content online.

Search for reports about the events in question in other news sources. Search for the first date of publishing.

The objective of verifying the source of the content is to know if the person or account publishing the content is reliable or not. Asking the following questions may help:

- Is the source credible. Who are they? Where are they? Are you familiar with this account? Was the past content reliable? What is the nature of the content that was previously uploaded?
- Check the uploader's history on social media. How active are they on the account, and what do they talk about and share? Where do they reside based on the account initiation data?
- Check their friends and followers on social networks. Who do they follow and who are their followers? Whom do they interact with? Are they on the list of other people or not?
- Try to find other accounts related to the same name or username on other social networks in order to find more information. If you find a real name, use people-searching tools such as Spokeo, White Pages, Pipl.com, WebMii to find contact information. Social networks like LinkedIn can also be used to learn more about a person's professional background.
- Check if the account of the person on Facebook or Twitter is already authenticated by testing the authentication mark (blue tick mark). By passing the mouse over the blue mark, you will see the words "page verified", if it is.



## Tips for verifying an image

- Stay updated on new the tools for determining the origin of images online spring up from time to time. In 2020, search engines such as Google Image Search or TinEye are helpful.
- To verify an image save it on your computer or copy the link. Upload the image or paste the link of the image on Google Image Search and compare the results to your image. Keep an eye out for the largest file sizes as usually the largest image is the original one. Check the publishing date in the search results, as the oldest images are most likely to be the original ones.
- Check the image file's EXIF data, or the so-called metadata. This is a standard format for storing interchange information in digital photography image files. For example, when taking a picture using a digital camera or smart phone, the image retains information such as type of camera, image dimension and date of capture. However, the time data cannot be taken as an absolute truth, since it can be set manually on the camera. To find the EXIF data, you can use free software and tools such as Jeffrey's EXIF viewer, Fotoforensics.com and Findexif.com, or simply right-click on the image and click on Image Properties.
- EXIF data often disappears when the images are uploaded to social media sites, but are saved if photos are sent via email. Social networks such as Twitter, Facebook and Instagram extract the metadata. To search for the hidden metadata, you can use Geofeedia or Ban.jo. Also, this data can vary if the image was modified by, for example, Photoshop, so EXIF data cannot always be absolutely trusted. Use sites like "Image edited?" to detect image manipulation using Photoshop, for example.
- To verify the alleged time and place of an image, check the geographical location of the images. There are tools that could help you determine the GPS location and check if the image was taken at the alleged place or not. Search for reference points to compare them with the satellite images and the geographically located images, such as signs, numbers, letters, signs on buildings, streets, and licence plates. Also, search for streets or known natural characteristics such as mountains, trees, slopes, rivers, etc. and check monuments and buildings such as minarets, churches, stadia, bridges and so on. Use Google Maps, Google Street View, and Google Earth to check whether the old and located images match the terrain and location of the image you want to check. You can also use WikiMapia to define the features.
- Some services like Flickr, Picasa and Twitter offer the option to include the location of where the image was taken, noting that it is not guaranteed to be the truth.

- Check the details, pay attention to the clothes, buildings and architecture, licence plates and weather. Linking all these elements can help determine if the content is logical and true or not.
- An effective way to verify a photo is to communicate with the person who uploaded the image, and then to ask whether they took the image or not. The tracking process often starts with the person who uploaded it and ends with the one who captured it. When communicating with the source, compare their answers with the information you obtained through your own search and make sure they match your findings. You can also ask the source for additional images, taken before and after the image to be verified.
- Use logic and your instinct during the verification process. Not all information needs tools and programs. For example, does the description or explanation accompanying the image match the image or not? Does the content seem logical and relevant to the context described? Are there any irregularities in the content that are misplaced and hard to believe? Do source information and details contradict each other?

it was posted. Search for any Photoshop tampering of the image and the parties behind posting it.

5. **Verify the video:** Upload the video thumb on YouTube or Google. Check where it had been posted and verify the identity of the poster. Analyse the images' locations in the video. Listen to any sound effects. Follow the cutting and montage. Check the YouTube uploading time.
6. **Verify the posting and tweets:** do not believe any post or tweet in PDF format. Go to the original account owner and make sure the posting or tweet are on their account. Ensure that nobody had hacked the accounts you are verifying.

Network users have two types of verification available. The first is closed verification carried out by the user alone or through a special contact with other sources or users. The second is open verification through investigating the information integrity of the network by interacting with other users.

# 8

# UNDERSTANDING media ADVOCACY

**M**edia advocacy includes all communication, which aspires to the exertion of influence. It is a broad concept, under which things such as sending announcements, advertising, sales work, lobbying, political speeches, religious sermons, demonstrations or salary negotiations can be grouped.

Media advocacy is conducted for various reasons, but generally aims at attracting the public's attention to a person's or company's goals. It can aim to increase public visibility and interest so that the parties whom the communicator represents can tell their

own stories with their own words. It can also aim to pressurise or persuade decision-makers.

Different public, private and civil institutions have a huge amount of information. In order to reach out to the public, they often cooperate with the media.

## **Differences between public relations officers and journalists**

A public relations officer (or media spokesperson or press officer) is a communications professional whose task is to communicate

about the functions of the organisation, cause or the individual they are representing. Public relations officers are often employed in companies and associations, but events like festivals and popular figures like politicians or celebrities can also have their own public relations officers.

A public relations officer has a dual role. On one hand, they convey the message of their institution, explain its programmes, illustrate its achievements, respond to critics and correct misinformation. On the other hand, they provide the media with needed information and communicate journalists' and stakeholders' needs to their institution, thus encouraging cooperation.

The most common tasks for a public relations officer may include writing press releases and articles, organising press conferences, editing customer and personnel magazines, annual reports, flyers and other printed products or communications material and online communications. They may, for example, write speeches or statements for the represented organisation's CEO, politician or expert. Public relations officers may also call journalists and try to convince them to participate in press conferences or to make news about the party or person they represent.

Whereas public relations officers need journalists to reach out to large audiences, maintaining good connections to public relations officers is also important for journalists. Firstly, interviews are often agreed via public relations personnel. Secondly, press releases or even private calls from communication personnel are important information sources from which journalists can pick some potential topics for their articles.

A public relation officer's job description can be very similar to a journalist's, but can

i

## Qualities of a good press release

A good press release is:

- easy to read and written in clear language
- contains editable quotations and concrete facts, which help the work of a journalist taking up the case.
- contains contact information for requesting further information and guidance to the other possible locations where more information is available.

also be completely different. The values and ethical guidelines that steer the work of journalists do not, however, in principle bind public relations officers in the same way as they do journalists. A public relations officer is not supposed to be independent in relation to the party they represent. This is good to keep in mind when encountering, for example, press releases or articles on a company's magazine: they may seem very professional and neutral, but they may or may not be impartial and objective.

Nevertheless, the job descriptions of a journalist and a public relations officer have, in recent years, moved closer to one another as a result of the ongoing change in media. Whereas many media outlets struggle to find new methods of funding in the digital era,

the tasks in public relations and the amounts of funds allocated to it have prospered substantially with the increase in the use of social media as platforms for publishing, mobilisation, funded advertising and networking. In consequence, many journalists who have been laid off from their news work have moved to “the other side of the fence”, and started work in public relations.

## **Lobbying is convincing with arguments**

Lobbying as a word comes from the place where politics is often done, the lobby of an office. Lobbying is the work of exerting influence and providing the communication that happens behind the scenes of democracy. In lobbying, the representatives of interest groups try to influence, in an unofficial manner, the decision-makers who are crucial to a certain issue. Through these activities, the representatives aim to affect the decision-making process that concerns the group they represent.

Lobbyists can represent, for example, corporations, consulting firms, interest groups or groups of citizens. Parties that are being lobbied can be policy-makers, officials, the media or people with the opposite outlook on the issue.

Lobbying has a bad reputation. In the gloomiest images, lobbying can be seen as secret influencing of decision-makers by powerful business elites and campaign funders that leave our democratically elected representatives as nothing but puppets. This fear is reinforced by the so-called “revolving door phenomenon”, in which people in positions of power become lobbyists for the business world, and vice versa.

Lobbying does not, however, in principle, have anything to do with corruption or bribery. Lobbying is first and foremost about trying to convince the other person by presenting strong arguments, facts and figures. When understood in a positive sense, lobbying is the exchange of information and networking, which is based on discussion, expertise and arguments.

To offer the political system transparency, the European Union and the United States use a lobbying register into which lobbyists enter the parties they are lobbying for and the budgets they are doing it with.

## **Marketing communications**

Marketing communications include advertising, public relations work, sponsoring, sales promotion through discounts, offers, competitions, fairs and sales work, which happen between the representative of the corporation and the customer.

Advertising is a very common form of marketing communications. Advertising is paid, target-oriented communications, which is often aimed at a large audience. Advertising persuades the audience to consume, increases market shares and makes corporations grow. Advertisements can be used to inform the audience of items, services, causes or people.

Advertising is often done through different media and social media channels. Advertisements are present in newspapers and magazines, on the radio, on television, at cinemas and on the internet. Social media has also given space for influencer marketing, where celebrities and micro-celebrities endorse products.

A rather topical form of advertising worth mentioning here is an advertorial. An adver-



torial is an advertisement made in journalistic style, visually and content-wise resembling a regular magazine article. When advertorials first appear in the pages of magazines or newspapers, it was often difficult to distinguish between them and the journalistic content of the magazine. That's why many ethical guidelines have now clear instructions about how this type of content marketing should be separated clearly so as not to mislead the reader.

Publishing advertisements in the media involves two parties. The advertiser associates the publication with the corporation behind the advertisement, and sometimes with troubles concerning its reputation. From the advertiser's point of view, buying media space from different magazines, newspapers and media is affected by the content, alignment, readership and image of the media in question. The advertiser is associated with these factors by publishing an advertisement in the said media. The advertisement can affect the corporation's image if the content of the media that supplied the advertising space is deemed questionable by the public.

Media advertising may have problematic side effects in terms of the reliability of journalism. Media channels that sell advertising space are sometimes more careful than those that finance their activities solely through subscription or support fees or taxes. For example, the media outlet not necessarily dare to criticise corporations that buy advertising space from them.

Influencer marketing has become a key tool in marketing communications. Celebrities are individuals who are well-known because of their careers or some other reason. So-called micro-celebrities, on the other hand, are individuals who have worked to increase their online value, for example



## Tips and prohibitions for media spokespersons

The basic rule is to keep professional relationships between journalists and media spokespersons based on the reciprocal need of each party for the other.

- Never lie
- Admit a mistake/problem if any
- Correct your errors quickly, especially in social media
- Do not improvise or guess
- Do not avoid journalists' calls.

through the number of followers they have on their social media accounts or other significant media exposure. In influencer marketing, both are used by brands and organisations to increase sales or advance a cause. For example, in 2019 one of the world's most famous micro-celebrities, Kim Kardashian West, was able to earn up to half a million dollars through one endorsement campaign due to her position as one of the most followed individuals on Instagram. Micro-celebrities can be used locally, nationally or globally depending on their value and reputation.

Propaganda is (media) advocacy with the purpose of affecting people's thoughts, emotions, attitudes and behaviour. Propa-

## Limitations on the media coverage of the elections in Palestine

The Palestinian Law comprises many articles related to the organisation of the media coverage of the elections, including the campaigns of candidates, the polling day, the day the results are announced as well as observing/oversight over the electoral process.

The articles of the law provide for establishing a committee jointly with the mass media to prepare a specific programme with the allocated schedule for liberal and free-of-charge media coverage for all candidates and electoral lists, taking into consideration the necessity of ensuring equal opportunities for candidates and lists. Objections to the programme must be presented to the Committee within 24 hours, at most.

Here are some interesting excerpts from the law:

### **Tone and location**

Article 66 prohibits the defamation or insulting of other candidates, the organisation of political rallies in mosques or churches or near hospitals or public institutions, placing electoral posters or banners in public venues not allocated to the electoral campaign, using the Palestinian National Authority logo in any of their electoral campaign and using

government cars and equipment in the electoral campaign. This article holds the manager or coordinator of the electoral campaign accountable for ensuring compliance with the above-mentioned provisions.

### **Campaign signs**

Article 67 concerns the removal of the campaign signs. Electoral lists shall remove all their campaign signs within two weeks of the end of the electoral process. The Committee shall impose a guarantee of at least USD 10,000 guarantee to ensure the adherence of the list to the electoral campaign provisions.

### **Funding of campaigns**

Article 68 concerns the sources of funding for the electoral campaign. Electoral candidates shall not, directly or indirectly, receive any funds for the electoral campaigns from non-Palestinian foreign or external sources. Each candidate shall submit, within one month at most of the announcing the final results, a detailed statement of their funding sources. Moreover, the Committee may request the audits of the financial statements by a certified auditor.

Article 69 concerns the limitations of campaign spending. Candidates may not spend more than USD 1 million or its equivalent.

### **Media coverage**

Article 70 concerns observing the elections and media coverage. Accordingly, the electoral process shall be conducted transparently and publicly to enable the observers and the media to observe it. All local and international observers and journalism and media representatives shall be accredited by the Committee. The Committee shall issue a card for such observers and representatives. All election personnel, including but not limited to the police, shall facilitate the aforesaid process.

The Central Elections Commission approved an accreditation system for journalists for both the general and local elections and for the SPJ Code of Ethics while covering the electoral process.

## **i**

### **Determinants of commercial publicity in Palestine**

The Palestinian Press and Publications Law No. 9 of 1995 prohibits:

- 1.** making use of press material for commercial advertising
- 2.** misusing one's position as a news journalist to advertise something or unduly criticise something, or make unfair comparisons between companies or enterprises.
- 3.** the media from carrying advertisements to promote medicines, pharmaceuticals and cigarettes, unless authorised by the Ministry of Health.

In addition, Article 40 of the Law obliges the press to candidly and clearly distinguish between remunerated advertisements and press materials.



## Political campaigns affected by advocacy

The role of social media in political campaigns has been under scrutiny since the end of the 2010s. One of the most scrutinised cases is the 2016 election and campaign victory of Donald Trump. In the middle of the debate is the Internet Research Agency (IRA), which is closely tied to the Russian government, and which has openly been called a “troll factory” (Bertrand 2017). A research article by Bastos and Farkas (2019) describes the propaganda activities of IRA through a study of 826 Twitter user profiles and 6,377 tweets by the agency. In their study, they found short-, medium and long-term propaganda campaigns tailored to campaigns such as Pro-Russia, Pro-Trump and Black-Lives-Matter activists. Some other researchers, Fiegerman and Byers, investigated the same speculation in 2017, and in 2018 Twitter announced that its service was carrying 3,814 IRA-linked accounts, which indicates the scales of the IRA’s activities. Reflection: what could governments or social media enterprises do to fight harmful forms of internet activism during political campaigns?

ganda techniques can include, for example, aggravation, exaggeration and keeping quiet about alternatives. Propaganda often includes partial and loaded information, sometimes downright lies.

A straightforward definition of propaganda is difficult, partly due to its bad reputation. The act of definition carries with it the risk of bias: the opinions of the opposing side are often labelled as propaganda. For example, the election posters of a certain party can be considered propagandistic by their opponents.

States often regulate what can be advertised. The advertising of something – a product or an idea or even a human right – can be forbidden altogether.

## Critical reading and good practice of marketing

Advertisements affect our worldview, both consciously and subconsciously. The imagery transmitted through advertisements moulds our reality and our understanding of society, values and human nature. Like journalism, advertising and marketing are regulated by the principles of good practice, which are often defined in legal text.

The first step in becoming a critical reader of marketing is understanding that the main idea behind it is to generate interest and drive sales.

Many advertisements might be over the top and show a larger-than-life picture of the actual product. Nations usually therefore try to limit the overkills of marketing activities legislation, for example by making it mandatory to show the “real picture” to the audience or consumers. That’s why the most extreme advertisements come with



## Glossary of marketing and advertising

### Advertorial

An advertisement made in journalistic style, which visually and content-wise resembles a regular magazine article. For example, many women's magazines sell to their advertisers the rights to use the magazine's fonts, colours and other visual techniques.

### Media advertising

Advertising that is trying to reach a large audience through media. Forms of media advertising include television and radio commercials.

### Product placement

The placement of a product, service or trademark in a movie, series, sportscast

or entertainment programme for a fee. Sometimes this is done very subtly, so that the receiver doesn't realise the commercial ambitions behind what they see. This kind of "subliminal advertising" could include the brand of the main protagonist's car.

### Social media marketing

Marketing and advertising through social media channels.

### Sponsoring

The funding or other financial support of events, athletes or TV programmes that aims at increased sales of the sponsor's products or services, or at increased knowledge of the brand name.

disclaimers and warnings, so that the consumer knows that the stunts, actions performed in the advertisement are done by trained professionals and should not be attempted at home.

In general, the same legal and ethical principles that govern media and publishing apply to marketing. The only exception is journalism, which usually also follows self-regulation guidelines that are much stricter than the national laws. Often the use of violence and discrimination can be forbidden in advertising. Discriminating advertising means how a group of people is subordinated, degraded

or insulted in advertising on the basis of gender, sexuality, religion, race or disability. Advertising must not reinforce discriminatory attitudes present in society.

There are also usually specific regulations relating to advertising aimed at children. A threatening or frightening advertisement may be contrary to law or good practice when the advertisement can reach children, even if it is not aimed at children. Under-age people should not encounter advertisements that contain sexual impulses inappropriate to their age group or level of development, for example.

An advertisement must be recognisable as an advertisement regardless of the way it is presented and its format. The consumer has the right to know when they are being subjected to commercial persuasion. Also, influencers must disclose if they are producing content related to products that they co-operate with. In outdoor advertising, public space is used, and one cannot avoid encountering advertising. That is why an advertisement on

a billboard, shop window or in public transportation must be considered more deeply.

Despite this, an advertisement is not necessarily contrary to good practice, even if many people think that it is vulgar or that it arouses unfavourable images.

In addition to law and ethics, there is another point to this story. Following good practice in advertising also has implications for the societal responsibility of the corporation.



## Headline posters and placards

Placards and headline posters are the advertising posters of evening newspapers. Their objective is to sell the paper through punchy headlines and eye-catching images.

Aggravation is a part of media publishing, especially in headline posters. The headlines display only one attention-raising point, even on complicated topics. Instances of violence, conflicts, revelations and opposites are common positions in headline posters.

From time to time, public discussion is raised on the ethics of headline posters. One reason for this is that the content of articles is not necessarily equivalent

to the message printed on the posters. According to good journalistic practice, the headline should be supported by the content. The aggravations of headline posters can also be problematic in the light of the principle of truthfulness.

Another common reason for criticism is that the posters are often in plain view on the streets and at store counters, which also makes children recipients of their messages.

**Reflection:** Who is responsible for the ethics of placards? The journalist or someone else? What could journalists do themselves to avoid unethical headlines or placards?

# 9

# INTRODUCTION TO **human** RIGHTS

*“All human beings are born free and equal in dignity and rights. They are endowed with reason and conscience and should act towards one another in a spirit of brotherhood.”*

Article 1, Universal Declaration of Human Rights, United Nations (UN), 1948

**T**he starting point for human rights is based on morals: human rights state that human value is associated with humanity. The purpose of human rights is to live a life worthy of a human being.

Characteristics of human rights include universality, inalienability and fundamentality. Universality means that human rights belong to all people in the world, based on

the fact that they are human. They apply to everyone regardless of age, ethnic origin, religion, sexual orientation, nationality, culture, gender, race, disability or any other characteristic. Inalienability refers to the fact that human rights are acquired at birth and no one can relinquish them, for example sell themselves into slavery, even if they want to. Fundamentality means that only very important rights are included in human rights, such

as the freedom of speech, the right to life and the right not to be tortured.

When human rights are not adhered to, it is a human rights violation.

Even though human rights are universal, their realisation and promotion is in practice the responsibility of nation states.

## **Most important human rights documents and agreements**

The most important human rights document is the UN Universal Declaration of Human Rights, which was created after the Second World War in 1948. Officially, the declaration is a morally binding mission statement by governments. It has, however, become legally binding based on international common law.

The Universal Declaration includes an introduction and 30 articles. It covers rights extensively from the rights to life and freedom from slavery to the right to education, freedom of religion and thought, adequate standard of living and the right to apply for and enjoy asylum.

In the eyes of the international community, every country is primarily responsible for human rights being respected within its borders. The obligation also applies to foreigners staying in the country.

A state that is a party to suspected human rights violations can be taken to an international court of human rights. Additionally, states or individuals who are guilty of severe human rights violations, such as war crimes or genocide, can be taken to an international criminal court. This happened, for example, in the case of the Rwandan genocide.

The most important human rights agreements are the International Covenant on Civ-

il and Political Rights (ICCPR) and the International Covenant on Economic, Social and Cultural Rights (ICESCR). The preparation of the covenants was initiated right after the creation of the Universal Declaration, and they were approved by the UN General Assembly in 1966. The Universal Declaration and these two covenants form the foundation of the UN human rights system. They are occasionally referred to as the International Bill of Rights.

## **Three generations of human rights**

Human rights are often referred to as having three “generations”.

The first generation is civil and political rights. They are based on securing a certain sphere of freedom for an individual in relation to public power, and enabling political participation. These rights are often about the freedom to enjoy something, which is why they are often referred to as freedom rights. The first-generation rights include the right to life and freedom of speech and religion.

The second generation is the economic, social and cultural rights. These concern the right to have or own something and they deal with the prerequisites of a person’s true well-being, the realisation of which also requires resources from the society. It is characteristic of these rights that they are not realised simply by public powers not interfering on an individual’s rights. The second-generation rights are, for example, the right to be employed in just and favourable conditions, and rights to food, housing and health care.

The third generation is the collective or so-called solidarity rights. The foundation of



solidarity rights is the principle formulated in the UN Charter about the autonomy of people. Additionally, they are based on of the 28<sup>th</sup> article of the Declaration of Human Rights, according to which everyone has the right to the kind of societal and international order under which the rights and duties outlined in the declaration can be fully realised. There are no binding contracts on these third-generation human rights but, in recent decades,

for example, the right to development and the right to a clean environment have been strongly featured at global conferences.

Although perhaps a useful tool, this division has been criticised for giving precedence to the freedom rights that are most important to the Western world. The Cold War-era conflict between the stresses on freedom rights in the capitalist world and economic, social and cultural rights in Communist societies shows



## Human rights agreements in the Palestinian territories

Palestinian independence has not yet been recognized everywhere, and it is not a full member of the United Nations. As such, it is not by itself a party to any of the UN human rights agreements. Palestine has, however, achieved the position of observer state at the UN, which means the right to speak at UN General Assembly meetings, but not to vote on resolutions. Israel has signed most of the human rights agreements. The agreements apply indirectly to Palestine due to the Israeli occupation.

According to an Amnesty International annual report, human rights violations are a part of daily life, both in the occupied territories and in Israel. Palestinians both on the West Bank and in Gaza enjoy imperfect freedoms of speech, movement and assembly, and also suffer from arbitrary detention and imprisonments. According to the report, torture and beatings of arrested people are still widespread problems. The death penal-

ty also stands, and civilians are tried in unjust military courts. Women and girls face discrimination both in practice and in legislation. The protection of women against gender-based violence is also imperfect. The mobility of journalists is restricted.

From the viewpoint of supervising human rights, the current situation is problematic. If Israel and Palestine are one state, the human rights violations of Israel against the Palestinians are glaring. If we look at them as two states, Palestine is not a party to any agreement, and its citizens cannot appeal against violations in any court. Additionally, in this case it can be noticed that the sovereignty of the state is constantly violated.

**Reflection:** Do you think that Palestinians living under occupation have the opportunity to enjoy human rights? Why or why not?



## Excerpts from the Palestinian basic law:

### Article 10

"Basic human rights and liberties shall be protected and respected. The Palestinian National Authority shall work without delay to become a party to regional and international declarations and covenants that protect human rights".

### Article 14

"An accused person is considered innocent until proven guilty in a court of law that guarantees the accused the right to a defence. Any person accused in a criminal case shall be represented by a lawyer".

### Article 19

"Freedom of opinion may not be prejudiced. Every person shall have the right

to express his opinion and to circulate it orally, in writing or in any form of expression or art, with due consideration to the provisions of the law".

### Article 32

"Any violation of any personal freedom, of the sanctity of the private life of human beings, or of any of the rights or liberties that have been guaranteed by law or by this Basic Law shall be considered a crime. Criminal and civil cases resulting from such violations may not be subject to any statute of limitations. The National Authority shall guarantee a fair remedy to those who suffer from such damage".

**Reflection:** Do you think that the Palestinian basic law is respected by all the citizens?



## "The other factor"

Agreements ban direct discrimination on the following grounds: Gender, language, religion, race, skin colour, political or other opinion, ethnic, national or social background, minority membership, property, wealth, decent, medical condition, disability, sexual orientation, political or

professional activity. Additionally, there is always a mention of "Other position, factor".

**Reflection:** What could be such other position or factor?

that human rights are not free of ideology. In addition, the Universal Declaration of Human Rights has been criticised based on much the same logic. The universality of rights has been questioned and human rights have been seen as a value export from the West to other regions of the world.

Despite the occasional criticism, the right to life, to live without being tortured, equality, security, an adequate standard of living, peace and freedom are values, which can be justifiably argued as being universal.

When making divisions such as into “generations”, it is good to remember that the foundation of all rights lies in the declaration, and the declaration itself does not differentiate between the levels of importance of individual rights.

## Human rights dilemmas

To enjoy human rights, one also has the duty to respect the human rights of others. When two human rights contradict each other, a human rights dilemma arises.

Human rights dilemmas and their resolution are part of the work of human rights courts. Even though freedom of speech is the backbone of a democratic society, it can be restricted for certain, weighty reasons. The most common reasons that make governments restrict freedom of speech concern defamation, obscenity, pornography, inciting hatred, copyright violation, protection of privacy and maintaining general security and public order.

### i

## Determinants of harming reputation in British law

In British law, a statement may be considered harmful to a person’s reputation if it leads to any of the following:

- Exposes the person to hatred, ridicule or contempt.
- Results in desertion or in being neglected.
- Demeans and humiliates them in the community.
- Causes the person harm in their work, profession or business.

Journalists may not defend dishonouring a reputation on the pretext that their station or newspaper was only repeating a statement that had been previously published elsewhere. Likewise, it is not an acceptable defence for a publication to argue that it is only quoting another person, even if it encloses the quote in quotation marks.

Examples of basic and human rights that can conflict and cause dilemmas;

- Freedom of speech versus the protection of privacy and family life, and protection against defamation;
- Freedom of speech versus hate speech;
- The right to private property versus the right to a clean environment;
- The right to private property versus the right to an adequate standard of living;
- The right to freedom of movement and the right to enjoy asylum versus the sovereignty of nations;
- The right to life versus the death sentence (permitted, but regulated).

## The role of the media in human rights

The media is in a central position regarding the realisation of human rights. In an ideal situation, the media acts as the eyes and ears, reporting human rights violations and triumphs. According to the non-profit organisation established in 1985 in the defence and promotion of freedom of information, Reporters Without Borders (RSF), a free and aware media is a tool, which prevents the transformation of human rights violations into a part of everyday life.

Despite these ideals, the media not only witnesses and reports violations; it can also promote them.

History books and modern news feeds are filled with examples where the media has been harnessed by the ruling class, a particular political party or one side of an armed conflict, and made to act as a propaganda machine in order to advance an agenda.

The risk of this happening is particularly great in times of armed conflict, so critical



## Freedom of movement in the Palestinian territories

Based on reports by the International Federation of Journalists, Palestinian journalists are not able to travel freely in Israel. The Israeli authorities limit journalists' movement between the West Bank and East Jerusalem, between the West Bank or Gaza Strip and Israeli territories, and even within the West Bank, at 505 military inspection points. Both Palestinian press cards and International Federation of Journalists (IFJ) membership cards held by Palestinians are rejected, but these cards are recognised when held by Israeli journalists. The International Federation of Journalists has launched campaigns and expressed its discontent over the current situation over the past fifteen years to try and persuade the Israeli authorities to recognise press cards issued in occupied Palestine.

**Reflection:** Why do you think freedom of movement is important for journalists?

media literacy skills are in high demand, especially in conflict areas. It is also the role of the professional journalist internationally to try to recognise the motives behind one-sided or violence-infused communications, and report about them accordingly.

When human rights violations are reported, the ethical code of the media is important. The end must not justify the means. Journalism and citizens' journalism should aim to offer objective, accurate, truthful and balanced information to the general public and avoid misusing human rights terminology. Not all social injustices are human right violations – not to mention war crimes – and the role of the media is to be a witness to the facts, not a court of law. The weight of human rights language and the reliability of the journalist will be eroded if the terms are used repeatedly out-of-place in order to create a feeling of importance around an everyday topic.

## Freedom of speech is the foundation of journalistic work

Freedom of speech means the right to publicly express one's opinions. It also includes the right to seek and receive information without intervention from others. Freedom of speech is the requirement for securing many other central rights. Together with the freedom of peaceful assembly and association, it is one of the cornerstones of a democratic society. Free communication is also a condition for effective democracy as the "right to acquire and spread information through all media" is only realised if the media is free and independent.

Free press is a central enabler and exhibitor of freedom of speech. Freedom of speech is a very important right for journalists whose



### Are there limits for freedom of expression?

Article 19 of the Universal Declaration of Human Rights states the following: "Everyone has the right to freedom of opinion and expression; this right includes freedom to hold opinions without interference and to seek, receive and impart information and ideas through any media and regardless of frontiers."

**Reflection:** Can you come up with situations where freedom of opinion or expression should be limited?

work is based on the opportunity to present strongly critical views, for example of politicians and other decision-makers. Journalists must, however, adhere to good journalistic conduct in their work. This happens mainly through self-regulation.

In general, self-regulation is a guideline that is stricter and more accurate than international laws. Just because something is not condemned by the international courts, that does not make it ethical.

Freedom of speech occasionally clashes with rights to protect privacy and reputation. The guidelines relating to these conflicts vary among national laws and journalistic codes of conduct in different areas. To guarantee

# i

## Excerpts from international legislation on the freedom of speech

### Article 19.

1. Everyone shall have the right to hold opinions without interference.
2. Everyone shall have the right to freedom of expression; this right shall include freedom to seek, receive and impart information and ideas of all kinds, regardless of frontiers, either orally, in writing or in print, in the form of art, or through any other media of his choice.
3. The exercise of the rights provided for in paragraph 2 of this article carries with it special duties and responsibilities. It may therefore be subject to certain restrictions, but these shall only be such as are provided by law and are necessary: 1) For respect of the rights or reputations of others; 2) For the protection of national security or of public order (*ordre public*), or of public health or morals.

International Covenant on Civil and Political Rights

the realisation of freedom of speech, politicians can be criticised in harsher words by the media than private people, who have

not, by choosing their profession, placed themselves in a position of public power. In other words, the freedom of speech enjoyed by journalists is more extensive when the object of criticism is a politician, than when criticising “normal” people.

Freedom of speech is not a value that upholds itself. Freedom of speech is tested and reinforced daily both in journalistic work and in the lives of the general public. The freedom to receive information and to challenge the status quo by expressing criticism towards those in power is a fundamental right and the foundation of a functioning democracy.

## Censorship and violations of freedom of speech

Even though freedom of speech and expression is based on human rights agreements, in practice, freedom of speech is limited everywhere. One of the core tasks for advancing freedom of speech is prohibiting censorship.

The purpose of censorship is to change or stifle acts, thoughts or publications, which are seen as repulsive, harmful, politically unwanted or, for example, contrary to the interests of state officials. Censorship can be divided into preliminary censorship and post-publication, punitive censorship. Preliminary censorship is the check of vocal, literary or visual presentations, the passing of which is a condition for the public presentation and circulation of the publication. Punitive censorships sum up all the negative consequences that a citizen or a journalist may face when talking about or reporting on a certain topic. Worldwide, these include a wide range of consequences, from mild ones such as getting negative feedback, to graver ones such as imprisonment and even death.



## Palestinian national legislation on freedom of expression

The Palestinian Press and Publications Law No. 9 of 1995, Article 4 Freedom of expression includes the following texts:

1. Informing citizens of facts, ideas, trends and information from local, Arab, Islamic and international sources
2. Allow citizens to publish their opinions
3. Freedom of the press also includes the search for information, news and statistics of interest to the public from different sources and their analysis, circulation, dissemination and commentary within the boundaries of the law
4. The right of the printed press, news agency, editor and journalist to keep sources of information and news confidential unless the court decides otherwise to protect national security or stop a crime or serve justice
5. The right of citizens, political parties, social and cultural institutions and trade unions to express their opinion, thought and achievements in areas of their activities through publications.

**Reflection:** What sort of thoughts does this law raise? Is it comprehensive? What do you think about the section “unless the court decides otherwise to protect national security or stop a crime or serve justice”? What could be a legitimate situation for such a ruling by the court?

Making the work of journalists harder is one of the means of censorship. Documenting and reporting these abuses against journalists and citizen journalists are among the core tasks of Reporters Without Borders (RSF).

Since 2002, RSF has been publishing the World Press Freedom Index. This index is a ranking list of 180 countries in which the national freedom of the press has been researched and analysed through a questionnaire and local correspondents. The index is a points-based system where every country receives a comparison score between 0 and 100. The score is calculated by separately assessing the multivocality and diversity of values

within the media, independence of the media, self-censorship, legislation, openness, transparency and media infrastructure. Additionally, the score takes into account the violence that journalists have been subjected to, which is counted as the numbers of deaths, imprisonments, detainments and the number of journalists who have been exiled.

The top positions tend to be occupied by the Nordic countries Finland, Norway, Sweden and Denmark whilst, at the other end of the scale, from 2013 to 2019 the index has ranked Palestine at 132–146 out of 180 and Israel at 87–112.

Even though, as a continent, Europe is still in the lead, the rights of journalists are

# i

## Examples of the censorship and self-censorship of journalists in Palestine

Palestinian journalists are under stress from several directions. The media landscape is greatly politicised both in Israel and in Palestine, and group or political party identification of journalists is a very common problem.

Here is a list of six different types of censorship in Palestine:

- 1. Israeli (military) censorship.** Palestinian journalists have no free access to Israel, nor will they be granted a press card. Their work is hindered, for example by confiscating their material or by destroying their editorial equipment. Journalists can be arrested without specifying a reason.
- 2. a) Palestinian Authority censorship** in West Bank (censorship by the self-government body), which prevents journalists from accessing information sources, arrests and threatens them.  
**b) Hamas censorship** in Gaza is a degree more extreme. The life of the journalist can be in danger if their articles are contrary to Hamas' viewpoint.
- 3. Editorial censorship.** The managing editor or editor-in-chief intervenes in an article for non-journalistic reasons. This often has to do with financial pressures from advertisers or threats from officials to close down the functions of the media office.
- 4. Financial censorship.** Advertisements are pulled due to an over-critical tone of writing or advertisers' campaign against the sales of newsstand copies.
- 5. Self-censorship.** According to the Press Freedom Index, one of the greatest challenges for journalists working in Palestine, both in Gaza and in the West Bank, is self-censorship. This type of censorship is connected to losing face where journalists are bound as guarantors of an own state for the Palestinians. For this reason, it is not suitable for journalists to publish articles on corruption, (for the absence of a law that gives access to information or the fear of losing foreign financial aid)

far from ideal even there. Reports have paid attention to, for example, the insufficient protection that the law provides in France for the sources of journalists. In one of the leading countries, Finland, the index has been paying attention to the centralisation of media ownership, which is an internationally common trend of development. Television corporations, radio stations, papers, etc. have

grouped into large media conglomerates, where many different media outlets function under the same roof.

The index is a point of reference that is quoted by media throughout the world and is used by diplomats and international entities such as the United Nations and World Bank. Because it is well known, its influence over governments is growing.



or the lack of governmental democracy (peace process and the dream of an independent state is endangered).

**6. Social censorship and self-censorship.** In addition to the previous type, social pressure, taboos and low wages make the work of journalists harder even if the threat of violence is not severe. This type of censorship can include family, kin and religious taboos. Issues like sexual minorities, domestic violence or neglecting children are seldom reported in an investigative manner, even if the talk on the street is free. As a consequence of handling such issues, local journalists might receive death threats, or might be shunned by their kin or local community.

---

Source: Tapio Kujala: Media War in the Middle East – The Cross-Pressures of Journalism in the Israeli – Palestinian Conflict.

Limiting the press not only affects professional journalists, but also the public, who cannot receive critical and independent knowledge through newspapers, radio or television. The internet is also constantly the object of espionage and surveillance.

Limiting freedom of speech is also often a tool of political power. One of the countries whose position has most significantly

dropped is the United States, whose ranking has fallen to 41–49 for the last five years, but which still held 20<sup>th</sup> place as late as 2010. This fall was first largely caused by the efforts made by the US government to track people who have leaked politically sensitive information, but the US position has been kept low largely due to direct attacks on the media by President Donald Trump.

In self-censorship, journalists limit their actions themselves. An example of self-censorship would be the reluctance to express thoughts that could be considered touchy by the government, or which could get the journalists into trouble. A wider definition of self-censorship is limiting one's own actions or statements in order to avoid offending or irritating, for example, a government.

## Discrimination, equality and the work of journalists

Discrimination means the unequal treatment or unequal positioning of people without an acceptable reason. The creation of a hostile, derogatory or humiliating atmosphere, or an order or request to discriminate are also forms of discrimination. The ban on discrimination includes the ban on counter-measures: no harmful consequences should be caused by acting to secure one's rights or by complaining about rights violations. Wholly separate human rights agreements have been created by the UN to counter common forms of discrimination. These include the International Convention on the Elimination of All Forms of Racial Discrimination (CERD, 1965), the Convention on the Elimination of All Forms of Discrimination against Women (CEDAW, 1979), Convention on the Rights of the Child (CRC, 1989), and the Conven-

tion on the Rights of Persons with Disabilities (2008).

Discrimination and gender equality are questions, which affect the whole journalistic work process. Multivocality – giving a voice to those who would not otherwise be heard – is an important goal in the field of media, but in practice it is not always realised.

The media bears great responsibility in

the realisation of equality. That is why equality must be kept in mind when topics and interviewees are being picked and also when the distribution of work within an editorial office is being made. People consume media regardless of their gender, religion and ethnic group identity, so it would be good if all groups also had access to producing journalistic content, regardless of the topic.



## Tips for avoiding discriminatory language when writing about women

- Focus on the substance instead of the appearance. Media reports on women in politics tend to focus on details like her supposed moods, diet, wardrobe and other aspects relevant to her appearance.
- Avoid the use of descriptions compatible with the traditional stereotype image of women such as saying a mother of six children or the wife of someone, unless it is justified by the context, or any descriptions that belittle or underestimate women, even indirectly such as saying a male nurse and female doctor.
- Avoid asking women the frequently repeated question of how she keeps a balance between her domestic tasks while occupying a public position. It is a way in which journalists remind women that they need to meet the expectations of their society as wives, mothers and family caretakers. Standards differ for men as they are not asked about parenting or family responsibilities. Instead women should be presented as independent citizens, not through their affiliation to a family or their marital status.
- Avoid portrayal of authority/power using male personal characteristics as the constant reference to the masculine features of authority will limit the prospects of female employment at this level. This implies that, in order to be a decision-maker, a woman must reflect behaviours associated with masculine traits, as if this were the only way to participate in or exercise authority.
- Question the prevalent media rhetoric. Most stereotype images and traditional practices are casual and not intended, but this is deeply rooted in the cultural and popular heritage of traditions and customs. Nevertheless, these practices should be questioned.



## International legislation on discrimination

### Article 2

"Everyone is entitled to all the rights and freedoms set forth in this Declaration, without distinction of any kind, such as race, colour, sex, language, religion, political or other opinion, national or social origin, property, birth or other status."

---

Universal Declaration of Human Rights  
Article 4



## Discrimination against women in the media

**Reflection:** Try the following game: count the number of times the names of female officials appear on the front page of local newspapers and compare these to the number of men's names, or count how many times journalists pay attention to the opinion of women when preparing their reports. What did you find? Who is given the floor most often in the media?

# BIBLIOGRAPHY

**This publication is based on and inspired by various printed and digital sources. Here is a list of them – you may find them useful for further reading.**

Ahmad Zaki Othman 'Al-Sawt al-Hurr' (Free Voice)  
The Arab Network for Media Support website,  
[bit.ly/1ZDUTqw](http://bit.ly/1ZDUTqw)

Amnesty International, Human Rights Reports,  
[www.amnestyusa.org/research/reports](http://www.amnestyusa.org/research/reports)

AP Statement of Ethical Principles,  
[www.apme.com/?page=EthicsStatement](http://www.apme.com/?page=EthicsStatement)

Bastos, Marco & Farkas, Johan. 2019. "Donald Trump Is My President!": The Internet Research Agency Propaganda Machine. *Social Media + Society*. July-September (2019), 1-13.

Bertrand, Natasha. (2017, October 30). Twitter will tell Congress that Russia's election meddling was worse than we first thought. Business Insider. Retrieved from <https://www.businessinsider.sg/twitter-russia-facebook-election-accounts-2017-10/>

Center for Journalism Ethics: Global media ethics  
[ethics.journalism.wisc.edu/resources/global-media-ethics](http://ethics.journalism.wisc.edu/resources/global-media-ethics)

Council for Mass Media in Finland,  
[www.journalistiliitto.fi/in-english](http://www.journalistiliitto.fi/in-english)

Elokuvantaju – Online study material for film studies, [elokuvantaju.aalto.fi](http://elokuvantaju.aalto.fi)

EthicNet – collection of codes of journalism ethics in Europe,  
[ethicnet.uta.fi/finland/guidelines\\_for\\_journalists](http://ethicnet.uta.fi/finland/guidelines_for_journalists)

Facebook Enterprise, official website blog,  
[www.facebook.com/business/news/Organic-Reach-on-Facebook](http://www.facebook.com/business/news/Organic-Reach-on-Facebook)

Fiegerman, Seth, Byers, Dylan (2017). Facebook, Twitter, Google defend their role in election. CNN. Retrieved from <http://money.cnn.com/2017/10/31/media/facebook-twitter-google-congress/index.html>

Haraszti, Miklós (2008): The media self-regulation guidebook,  
[www.osce.org/fom/31497?download=true](http://www.osce.org/fom/31497?download=true)

Hootsuite Enterprise, official website blog,  
[blog.hootsuite.com/the-2015-social-media-glossary-207-essential-definitions](http://blog.hootsuite.com/the-2015-social-media-glossary-207-essential-definitions)

International Federation of Journalists, IFJ,  
[www.ifj.org](http://www.ifj.org)

Ihmisoikeudet.net, Online study material on human rights,  
[www.ihmisoikeudet.net](http://www.ihmisoikeudet.net)

Jaakkola, Maarit: Hyvä journalismi: Käytännön opas kirjoittajalle. Kansanvalistusseura (2013).

Kujala, Tapio: Media War in the Middle East – The Cross-Pressures of Journalism in the Israeli-Palestinian Conflict. Tampere University Press, Tampere 2012.

Kunelius, Risto: Viestinnän vallassa – Johdatusta joukkoviestinnän kysymyksiin, WSOY 2003, 5.–7. painos 2009.

Lehtinen, Aki Petteri: Journalismin uusi objektiivisuus (2013), [etiikka.fi/media/journalismin-uusi-objektiivisuus](http://etiikka.fi/media/journalismin-uusi-objektiivisuus)

Nordenstreng, Kaarle & Lehtonen, Jaakko: Hyvän ja pahan kierrätystä. Viestinnän etiikan perusteita, in Kivikuru & Kunelius (toim.), Viestinnän jäljillä. WSOY 1998, 253–272, [www.uta.fi/cmt/opiskelu/opinto-opasjaopetusohjelma/viestinnan%20etiikan%20perusteet%202012](http://www.uta.fi/cmt/opiskelu/opinto-opasjaopetusohjelma/viestinnan%20etiikan%20perusteet%202012)

Nordenstreng, Kaarle (2012): Kansainvälinen oikeus ja etiikka journalismissa, [www.uta.fi/cmt/opiskelu/opinto-opasjaopetusohjelma/Kansainvalinen%20oikeus%20ja%20etiikka%2010\\_10.pdf](http://www.uta.fi/cmt/opiskelu/opinto-opasjaopetusohjelma/Kansainvalinen%20oikeus%20ja%20etiikka%2010_10.pdf)

Mäntylä, Jorma: Journalistin etiikka, Gaudeamus 2008.

Organization for Security and Co-Operation in Europe (OECE): The Media Self-regulation Guidebook, [www.osce.org/fom/31497?download=true](http://www.osce.org/fom/31497?download=true)

SPJ Code of Ethics, [www.spj.org/ethicscode.asp](http://www.spj.org/ethicscode.asp)

Stanley, Paul. Center for Communication, University of Miami Professional Field Guide for TV News; published by Media Development Center – Birzeit University.

TE-toimiston Ammattinetti (Online database of profession counseling produced by Work and Economic Development Office of Finland), [www.ammattinetti.fi](http://www.ammattinetti.fi)

Yle, Finland: Mediakompassi, [yle.fi/vintti/yle.fi/mediakompassi/mediakompassi](http://yle.fi/vintti/yle.fi/mediakompassi/mediakompassi)

Äänipää: Online study material for audio analysis, [www.aanipaa.tamk.fi/lahto\\_1.htm](http://www.aanipaa.tamk.fi/lahto_1.htm)

2015 World Press Freedom Index, [index.rsf.org/#/](http://index.rsf.org/#/)



## **In the era of digitalization, critical media literacy is an essential part of active citizenship.**

*Media Guide* provides tools that help the reader to understand the role of journalism in democracy, functions of the media and human rights and how to be an ethical professional or citizen journalist.

As people all around the world are spending more and more time on posting, blogging, sharing, liking and even starting their own online newspaper, the need for ethical and responsible journalism is crucial. Critical media literacy is needed both from journalists and consumers of media.

*Media Guide* is a survival kit designed both for professional journalists and citizen journalists, as well as anyone interested in journalism and media literacy. It deals with the working practices, ethics, work-related rights, freedom of speech and the power and responsibility related to the profession of journalism.

The reader will be given basic and up-to-date information on

- the principles and guidelines of journalism and critical media analysis
- visual and audio-visual journalism and critical reading of visual content and video editing.
- social media, media advocacy and critical reading of social media
- human rights.

ISBN 978-951-9140-74-2 Media Guide

ISBN 978-951-9140-75-9 Media Guide (web)

