

**NORTH KARELIA UNIVERSITY OF APPLIED SCIENCES**  
International Business Degree Programme

Alexandre Figueiredo (0701376, Alexandre.Figueiredo@edu.pkamk.fi)

**EVALUATION OF MARKET POTENTIAL OF BRAZIL FOR FOREST  
MACHINERY COMPANIES: CASE KESLA**

Thesis  
February, 2012

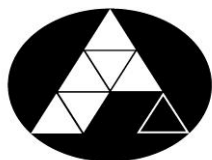

NORTH KARELIA  
UNIVERSITY OF APPLIED SCIENCES

**THESIS**  
**February 2012**  
**Degree Programme in International  
Business**  
Sirkkalantie 12A  
FIN - 80100 Joensuu  
Tel: +358 13 260 6703

Author

Alexandre Figueiredo

Title

Evaluation of Market Potential of Brazil for Forest Machinery Companies: Case Kesla

Abstract

Biomass is one of the sources for energy production with the greatest potential for growth in Brazil. It is considered one of the main alternatives to diversify sources of energy and consequent reduction of dependence on fossil fuels. Brazil is a country rich in forests, having 35 % of the native forests in the world. Brazil is also the largest producer of tropical wood and the fifth-largest industrial wood producer. Particularly the use of wood chips for energy generation has been growing in Brazil due to the interest of the Brazilian government to explore its natural resources and the continuous expansion of reforested Eucalyptus plantation areas. Brazilian economy has been growing at a rate of 4 % a year over the past eight years making it the largest economy in Latin America. The economic success of Brazil has been attracting investments from developed markets, which have risen up the exchange rate of Brazilian currency Real against the US Dollar thus making it easier for Brazilians to afford expensive machinery. Kesla Oyj is a Finnish manufacturer of forest machinery interested in entering the Brazilian bioenergy market. The purpose of this study developed on behalf of Kesla Oyj is to have an overview of the Brazilian wood chip market and to identify the best entry mode to be applied there. This study is based on interviews in Brazil, visiting companies, manufacturers and forest plantations in Brazil, and also on work experience at Kesla with professional colleagues. The study is also based on a thorough overview on the relevant, recent and up-to-date literature including books, scientific articles, company reports and administrative documents. This study revealed that the wood chip market in Brazil is active and potential for foreign investors. However, high import tariffs imposed by Brazilian authorities over manufactured goods are the main obstacle for Kesla Oyj to enter the market by its common entry mode, indirect exporting. The best options would be partnership with a strong dealer or a local manufacturer who could wholly or partially produce Kesla's products to avoid the high tariffs.

Language

English

Pages

86+23

Keywords

Wood chips, wood chippers, Brazil, Bioenergy, Renewable energy, Biomass

## CONTENTS

<b>1 INTRODUCTION</b> .....	6
1.1 Background .....	6
1.2 Aim of the study.....	8
1.3 Outline.....	9
<b>2 BIOENERGY IN BRAZIL</b> .....	11
2.1 Economy of Brazil .....	11
2.2 Geography of Brazil.....	13
2.3 Forestry in Brazil.....	14
2.3.1 Forests worldwide .....	14
2.3.2 Forests in Brazil .....	14
2.3.3 Forest productivity .....	22
2.3.4 Industrial forestry sector in Brazil.....	23
2.3.5 Tropical timber production in Brazil.....	26
2.3.6 Energy forests in Brazil.....	27
2.3.7 Wood loss in forest production chain .....	29
2.3.8 Energy matrix and bioenergy production in Brazil.....	33
<b>3 BIOMASS</b> .....	34
3.1 Types of biomass .....	34
3.2 Use of biomass in Brazil .....	35
3.3 Bioenergy and renewable energy sources in Brazil .....	39
3.4 Brazilian biomass incentive programs .....	45
<b>4 WOOD CHIPS</b> .....	47
4.1 Concept of a wood chip .....	47
4.2 Wood chipping in Brazil .....	48
4.3 Wood chips export from Brazil.....	50
4.4 Wood chippers .....	53
4.4.1 Disc chippers.....	53
4.4.2 Drum chippers.....	54
4.5 Mechanized harvesting methods and wood chipping in Brazil .....	57
<b>5. LEGISLATION AND CUSTOM PROCEDURES IN EXPORTING GOODS TO BRAZIL</b> .....	59
<b>6. OPPORTUNITIES FOR KESLA IN BRAZIL</b> .....	63
6.1 Demand and consumer market.....	63
6.2 Competitors in Brazil (wood chippers).....	63
6.3 Potential entry modes for Kesla .....	64

6.3.1 Indirect exporting .....	65
6.3.2 Direct exporting .....	66
6.3.3 Joint venturing.....	68
6.3.3.1 Licensing .....	68
6.3.3.2 Contract manufacturing.....	69
6.3.3.3 Joint ownership .....	70
6.3.3.4 Management contracting.....	70
6.3.4 Direct investment .....	71
6.4 Conclusions .....	71
REFERENCES.....	76

## TABLES

Table 1. Main bio-physical and forest indicators in Brazil.....	16
Table 2. Hardwood Productivity in Brazil and selected countries.....	24
Table 3. Softwood Productivity in Brazil and selected countries .....	24
Table 4. Quantity of wood biomass in Brazil .....	37
Table 5. MDF production, imports, exports and domestic consumption.....	50
Table 6. Related costs for forest equipment.....	62

## FIGURES

Figure 1. The most productive zone in the world for production of biomass is located between the Tropic of Cancer and the Tropic of Capricorn .....	7
Figure 2. 2012 FDI Confidence Index .....	12
Figure 3. Brazil FDI inflows, 2005-2010 (Millions of dollars) .....	13
Figure 4. Brazilian biomes map .....	14
Figure 5. The world's forests .....	15
Figure 6. Countries with the largest area of primary forest .....	16
Figure 7. Countries with greatest annual increase in planted forest area, 1990-2010 .....	17
Figure 9. Evolution of forest area planted with Pine and Eucalyptus from 2004 to 2009... ..	18
Figure 8. Distribution of planted forests in Brazil in 2009 .....	19
Figure 10. Distribution of Eucalyptus planted forests in Brazil in 2009 .....	20
Figure 11. Distribution of Pine planted forests in Brazil in 2009 .....	21
Figure 12. Certified forest area in five countries. FSC, PEFC and MTCS are different forest certification systems.....	22
Figure 13. Brazilian wood and non-wood production chain flowchart .....	25
Figure 14. Tropical timber production in Brazil 2008 .....	28
Figure 15. Biomass extraction from energy forests .....	30
Figure 16. Wood residues chain in the forestry industry .....	30
Figure 17. Biomass distribution in a tree .....	31
Figure 18. Forest industry operations and wood residues.....	32
Figure 19. Solid Biomass Sources .....	36
Figure 20. Brazilian forestry biomass supply by mass (10 <sup>6</sup> t/year) from energy forests.....	38
Figure 21. Production costs of electricity in Brazil.....	40
Figure 22. Potential of electricity generation from planted forests in Brazil.....	41

Figure 23. Domestic Electricity Supply in Brazil by Source 2009 .....	42
Figure 24. Distribution of wood residues power plants in Brazil .....	43
Figure 25. Boiler designed to heat industrial premises, central and municipal heating plants, farm buildings and hotels utilizing wood chip as fuel.....	44
Figure 26. Fuel wood exporters in 2010 .....	51
Figure 27. Main ports in Brazil .....	52
Figure 28. Disc chipper .....	54
Figure 29. Drum chipper .....	55
Figure 30. Schematic of a disc chipper .....	56
Figure 31. Schematic of a drum chipper .....	56
Figure 32. Evolution of entry mode decision.....	65
Figure 33. Kesla SWOT analysis .....	74

## APPENDICES

Appendix 1	A report of a visit to forest plantation at Veracel in 2008 with Kesla
Appendix 2	Locations of wood residues plants in Brazil
Appendix 3	A list of companies manufacturing wood chip boilers and furnaces in Brazil
Appendix 4	A list of companies commercializing wood chips
Appendix 5	Potential partners (wood chips) for Kesla in Brazil included with information in domestic models manufactured in Brazil
Appendix 6	A list of Kesla's competitors in Brazil

# 1 INTRODUCTION

## 1.1 Background

With the threat of climate change and global warming due to excessive emission of carbon dioxide in the atmosphere, many countries are researching and investing in carbon-neutral energy technologies. Bioenergy from sustainable planted forests is a good source of carbon neutral energy (Lattimore, Smith, Titus, Stupak and Egnell 2009). The increasing demand for alternative energy sources, especially renewable, has placed a great importance on the use of forest biomass as energy. For many years the use of fossil fuels such as coal, natural gas and oil contributed to an increase of carbon dioxide concentrations in the atmosphere. (Casper 2010). This had led to serious concerns about global warming and the adoption of the Kyoto Protocol in 1997. Besides environmental issues, the current consumption rate of non-renewable energy sources suggests that oil reserves will be depleted in a period of 40 years. (Pirages and Cousins 2008).

Biomass is one of the sources for energy production with the greatest potential for growth in Brazil. It is considered one of the main alternatives to diversify sources of energy and consequent reduction of dependence on fossil fuels. (Atlas de Energia Elétrica do Brasil 2008). Brazil is the 4<sup>th</sup> country in the world in renewable power capacity and the 2<sup>nd</sup> in biomass power (Renewable Energy Policy Network for the 21<sup>st</sup> Century 2010). Currently renewable energy represents 46.8 % of domestic energy use in Brazil, from which 10.2 % corresponds to firewood (Balanco Energético Nacional 2010: Ano Base 2009 2010). Brazil has also managed to reduce 34 % of its carbon dioxide emissions over the past five years and is close to reach its goal set for 2020 (39 %) (United Nations Climate Change Conference 2010). Brazil is a major producer and the largest consumer of forest products. Strategic sectors of the Brazilian economy, like steel, paper and packaging industry, and construction are highly dependent on the forest sector.

Brazil is located at 30° north latitude and 30° south latitude from the Equator line. This region between the Tropic of Cancer and Tropic of Capricorn has the most potential region for production of biomass in the world (Figure 1). Solar radiation is essential for biomass

production, and the region where Brazil is located, favors the country to receive intense solar radiation. Brazil is also the country which has the most favorable environment among the countries situated under this belt. The African region has the majority of its area constituted by desert, the same happening in Australia. Thus Brazil possesses one of the greatest potential for biomass production. (Plano Nacional de Energia 2030 2007). According to United Nations Development Programme (International Human Development Indicators 2009) Brazil has the largest stock of carbon in forests (49.335 MtC), 1½ times larger than Russian Federation and 2.6 times larger than United States (Walter, Dolzan and Piacente 2006). This is not surprising, because Brazil's forests account for 35 % of the primary forests in the world (Global Forest Resources – Assessments 2010).

The Brazilian environmental technologies market (including equipment, engineering / consulting services and instrumentation associated with pollution control and cleanup projects) was estimated in 2009 to be worth US\$9.0 billion. The economic growth projected for the next five years expects to boost the environmental industry market to grow 10 % annually. (Overview of Brazil 2010).

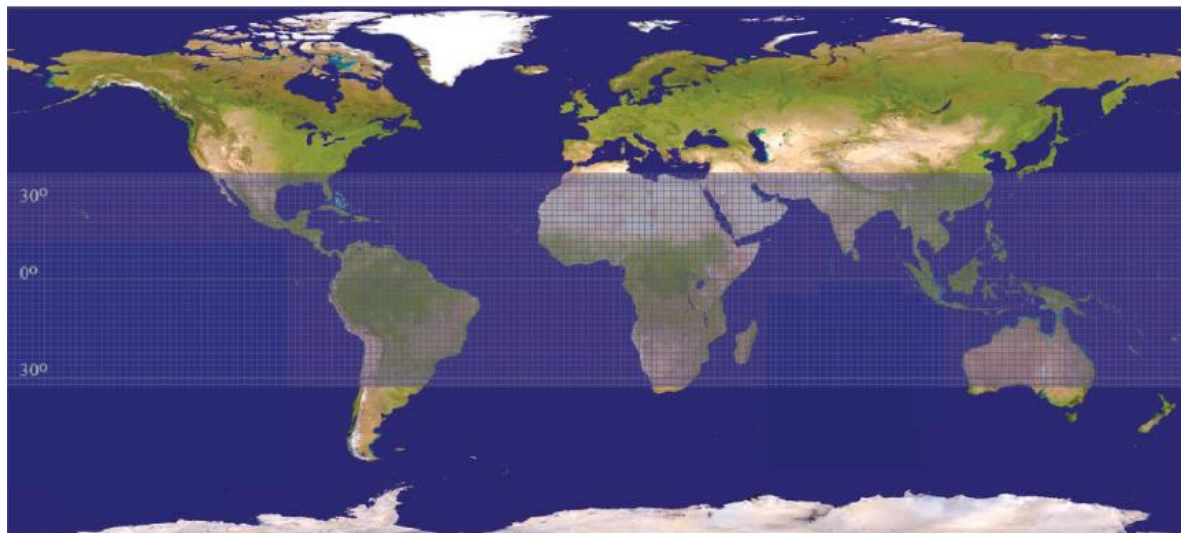

**Figure 1. The most productive zone in the world for production of biomass is located between the Tropic of Cancer and the Tropic of Capricorn (Source: PNE 2030:72)**

The Brazilian Energy Initiative was presented by the Brazilian Government during the World Summit on Sustainable Development in 2002. It was proposed that all countries would increase their share of renewables to 10 % in their energy matrix by the year 2010. The proposal was not accepted due to strong resistance imposed mainly by the United States, Japan, Australia, India, China and member countries of OPEC (Organization of Petroleum Exporting Countries) - except Venezuela. (Guardabassi 2006).

In order to be successful in its objectives, Brazil needs to be able to have enough machinery to attend the huge domestic and international demand of its biomass production. Manufacturers of forestry machinery like the Finnish company Kesla Oyj have interests in entering such an important market.

Kesla Oyj is a Finnish manufacturing corporation established in 1960. The company has four factories located in the east of Finland (Joensuu, Kesälahti, Ilomantsi and Tohmajärvi). Kesla is specialized in the design, manufacturing and marketing of forest machinery. Products of Kesla include timber loading cranes, industrial cranes and recycling cranes, harvester cranes, forwarder cranes, loaders and trailers, chippers, harvester heads, stroke delimiters and processors. Kesla operates internationally through independent dealers and does not have exclusive contract with any dealer. Kesla exports its products to the following countries: Sweden, Norway, Denmark, Belgium, Great Britain, France, Germany, Greece, Hungary, Ireland, Italy, Spain, Portugal, Netherlands, Switzerland, Austria, Czech Republic, Slovakia, Poland, Romania, Estonia, Latvia, Lithuania, Russia, Belarus, Canada, USA, Uruguay, Chile, Australia and Japan. (Kesla 2011).

## **1.2 Aim of the study**

This study has two major purposes: (1) to present the Brazilian wood chip market situation in Brazil and (2) to identify the best entry modes for companies in forest machinery industry to be applied to the Brazilian market.

This research focuses in the analysis of the Brazilian wood chip market and the potential entry modes for forestry companies (such as Kesla Oyj) to enter the Brazilian market. This study aims to cover different aspects involved in the wood chip market focusing mainly in



the forest situation, wood chip market factors and suitable entry modes available - based on the present situation in Brazil. Other biomass sources than wood chips are not included, and the analysis of the process concentrates only on information that is relevant for forestry companies such as Kesla.

Brazil is an important country for companies which are interested in exploring its bioenergy market. The Finnish company Kesla Oyj has a great interest to research the Brazilian wood chip market in order to develop the best strategy to enter this market. Certainly Brazil has one of the most attractive markets for companies in forest industry, but several aspects have to be considered carefully, including logistics, legislation, competition, demand and supply. This thesis has been made on behalf of Kesla Oyj to answer to these questions and needs.

### **1.3 Outline**

For every company it is important to base their decisions on recent and up-to-date information about the markets they have interest.

This study is based on a thorough overview on the relevant literature including books, scientific articles, company reports and administrative documents. Sources of information have been chosen to be the most reliable, recent and up-to-date for the needs of the companies, for which this study has been made. Finding all the needed information was challenging due to difficulties in the centralization and accessibility of information of the forest sector (Ministério do Meio Ambiente 2011).

The study begins with an overview of bioenergy in Brazil (chapter two). First, aspects like political climate for foreign direct investment in Brazil, competitive advantage and Brazil's position among BRIC countries are briefly presented. A short overview on Brazil's geography, its native and planted forests, the most utilized wood species and plantation areas are also given attention to in this chapter. Together with productivity, industry and tropical timber products, processes in forest industry are also presented. Energy forests and wood loss during harvesting operations introduce the potential that bioenergy in Brazil has.

The third chapter discusses biomass, renewable energy sources in Brazil and biomass incentive programs created by the Brazilian government to enhance the use of forest biomass as an energy source. The fourth chapter deals with wood chips, including basic information of the wood chips letting the reader learn what they are, where do they come from and why they are important as a source of renewable energy. Export of wood chips, machinery equipment (wood chippers), national and international competitors, and consumer market are presented with many important details. Chapter five has been dedicated to relevant legislation and customs procedures applicable to export forest machinery companies in Brazil. The study finally ends with chapter six, where business opportunities for Kesla are discussed. A SWOT analysis is also presented thus giving Kesla parameters to assess its position in the Brazilian market. This chapter introduces the most suitable entry modes based on this research and summarizes the most important findings and concluding remarks.

## 2 BIOENERGY IN BRAZIL

### 2.1 Economy of Brazil

Among BRIC countries China, India and Brazil are among the top five leading the Foreign Direct Investment Confidence Index in 2010. Brazil continues benefiting from the large international demand for iron ore and soybeans despite the global recession that is affecting especially European countries. Brazilian economy has been growing steadily at a rate of 4 % a year over the past eight years. According to Centre for Economics and Business Research (2011) Brazilian economy grew 7.5 % in 2010. Unemployment is at its lowest rate ever thus lifting nearly 49 million Brazilians into the middle and upper classes (Investing in a Rebound, The 2010 A.T. Kearney FDI Confidence Index 2010). The country is the largest economy in Latin America, the 6<sup>th</sup> largest economy in the world (Centre for Economics and Business Research 2011) and ranks as the 3<sup>rd</sup> most attractive destination for FDI (Figure 2) (Investing in a Rebound, The 2012 A.T. Kearney FDI Confidence Index 2012). FDI in Brazil has been growing since 2005 with exception of 2009 due to the global recession (Figure 3). However, Brazil was not deeply affected by the financial crisis and the government kept a good management of its fiscal and monetary affairs, trade balance and investment environment.

Brazil today is an example of political and macro-economic stability when compared to the United States and Europe. Brazil also became a creditor to the United States with \$344 billion (Banco Central do Brasil 2011) in foreign currency reserves. (*Financial Times*, 2 August 2011). In addition, investors perceive Brazilian debt as less risky than the United States debt according to the Credit Default Swap thus bearing a lower risk to Brazil thanks to its stronger fiscal position (*Reuters*, 15 June 2011). Standard & Poor's recently raised Brazil's long term foreign currency credit rating from "BBB-" to "BBB" due to a stable outlook with the government's commitments to its fiscal targets and prudent macroeconomic policies (Standard & Poor's 17 Nov 2011). Brazil is also the 3<sup>rd</sup> most attractive destination among heavy industries and 5<sup>th</sup> in light industry. The country is rich in agricultural and energy commodities, which helps the continuous growth despite the austerity of the financial crisis. (Investing in a Rebound, The 2010 A.T. Kearney FDI Confidence Index 2010). The economic success of Brazil has been attracting investments

from stagnant developed markets. These investments have risen up the exchange rate of Brazilian currency Real against the US\$ (*Financial Times*, 2 August 2011) thus making easier for Brazilians to afford expensive machinery. Brazil FDI inflows in 2010 were US\$ 48 billion (Figure 3). (Foreign Investment in Latin America and the Caribbean, 2008).

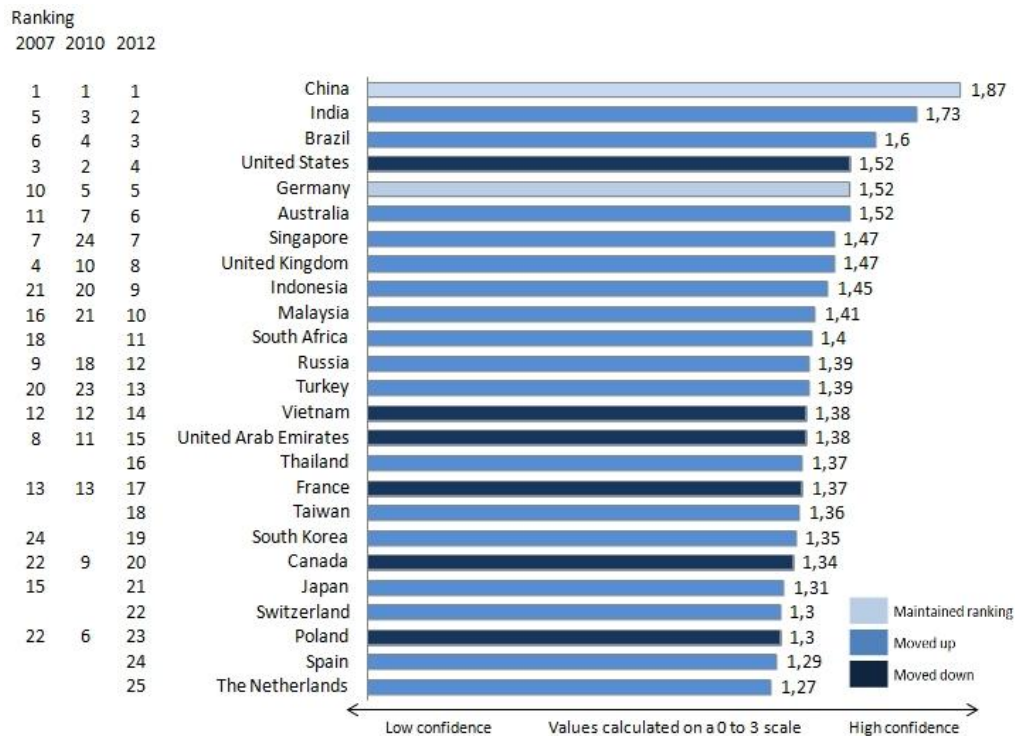

**Figure 2. 2012 FDI Confidence Index (Source: A.T:Kearney Foreign Direct Investment Confidence Index 2012)**

According to Goldman Sachs, Brazil has now the highest Growth Environment Score among the BRIC countries. The GES is designed to measure the strength of a country sustainable growth including 13 different variables, which are considered the main components that contribute to growth performance of a country. In the case of Brazil, strong advances in technology, economy and political conditions were the strongest components to raise the country to the top of the BRICs. The actual growth is still high in Brazil even after the financial crisis. Brazil is expected to become the 4<sup>th</sup> biggest economy in the world by overtaking Germany in 2029 and becoming the 3<sup>rd</sup> in 2034 by overtaking Japan. (O'Neill and Stupnytska 2009). According to the IPIAI index (Infrastructure Private Investment Attractiveness Index) developed by the World Economic Forum in 2007, the outstanding competitive advantages of Brazil were very low political risk, little unrest or

expropriation risk, well developed local capital market, good track record in private investment in infrastructure and a high level of private investment in infrastructure projects. Moreover, Brazil has a consolidated competitive advantage due to its large market size. The business sector is efficient and dynamic being one of the most sophisticated in the world. (Klaus Schwab 2010).

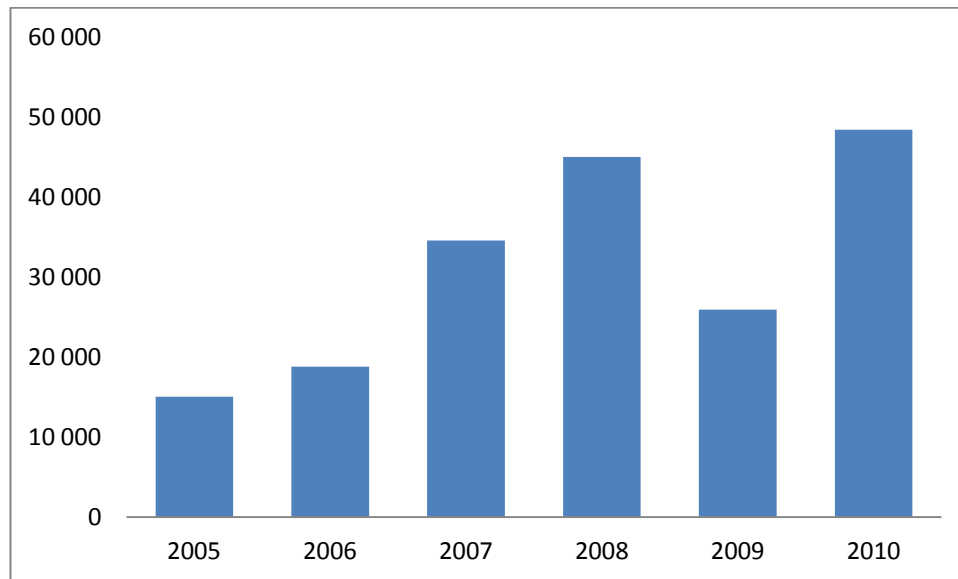

**Figure 3. Brazil FDI inflows, 2005-2010 (Millions of dollars) (Source: World Investment Report 2011:188)**

## 2.2 Geography of Brazil

Brazil is a country of continental dimensions. Its area of 8.5 million km<sup>2</sup> occupies almost half of South America. The country presents different climatic zones such as the humid tropics in the north, the semi-arid in the Northeast and the temperate in the South. For this reason Brazil possesses very distinct biomes: the Amazon Rainforest - the largest tropical rainforest in the world, the Pantanal - the largest wetland, the Cerrado's savannas and woodlands, the Caatinga's semiarid forests; the fields of the Pampas, and the tropical rainforest of the Atlantic Forest (Figure 4).

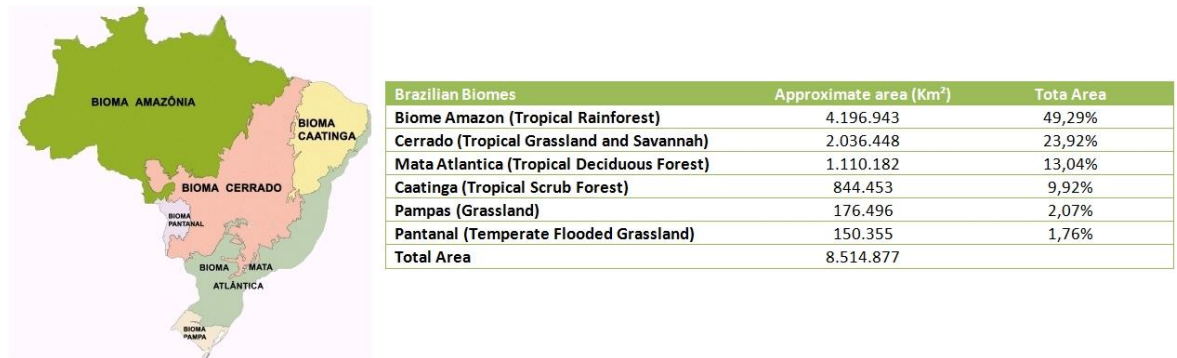

**Figure 4. Brazilian biomes map (Source: IBGE 2004)**

## 2.3 Forestry in Brazil

### 2.3.1 Forests worldwide

The world's total forest area is just above 4 billion hectares, covering 31 % of the total land area. The Russian Federation, Brazil, Canada, the United States and China are the most forest-rich countries possessing more than half of the world's total (Figure 5). Another 54 countries have forest on less than 10 % of their total land area and 10 countries have no forest at all. (Global Forest Resources Assessment 2010).

### 2.3.2 Forests in Brazil

Brazil has about two-thirds of its area covered with forests, equivalent to 543.9 million hectares (Serrano 2009). Brazil's forests alone correspond to 35 % of the world's forests (Figure 6), 30 % of the world tropical forests and 61 % of the South American forests. The main bio-physical and forest indicators in Brazil have been summed up in Table 1. While the world's total forest corresponds to an average of 0.6 hectares per inhabitant, Brazil has 3.2 hectares of forest per inhabitant. (Achieving the ITTO Objective 2000 and Sustainable Forest Management in Brazil 2002). Forest plantations account for about six million hectares and are mainly represented by Pine and Eucalyptus. A good example of a forest plantation is the company Veracel (Eunápolis, Bahia), of which more information can be found in Appendix 1. Brazil is the largest producer of tropical wood and the 5<sup>th</sup> largest industrial wood producer. (Dubé and Schmithüsen 2003). The forestry activities in Brazil

are concentrated mainly in two regions, the south and the north. The northern region of the country explores mostly native species, while the southern region bases its activities in rapid growth species. (Serrano 2009).

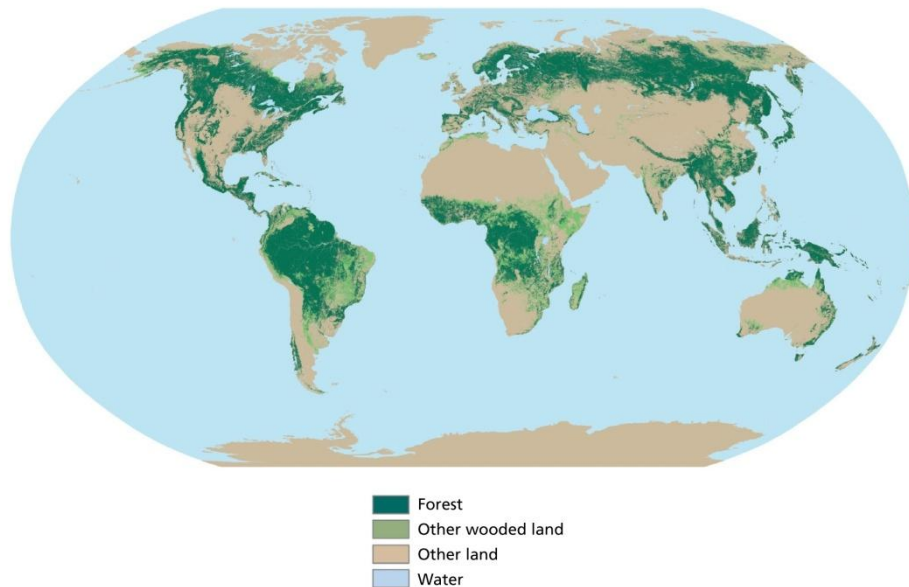
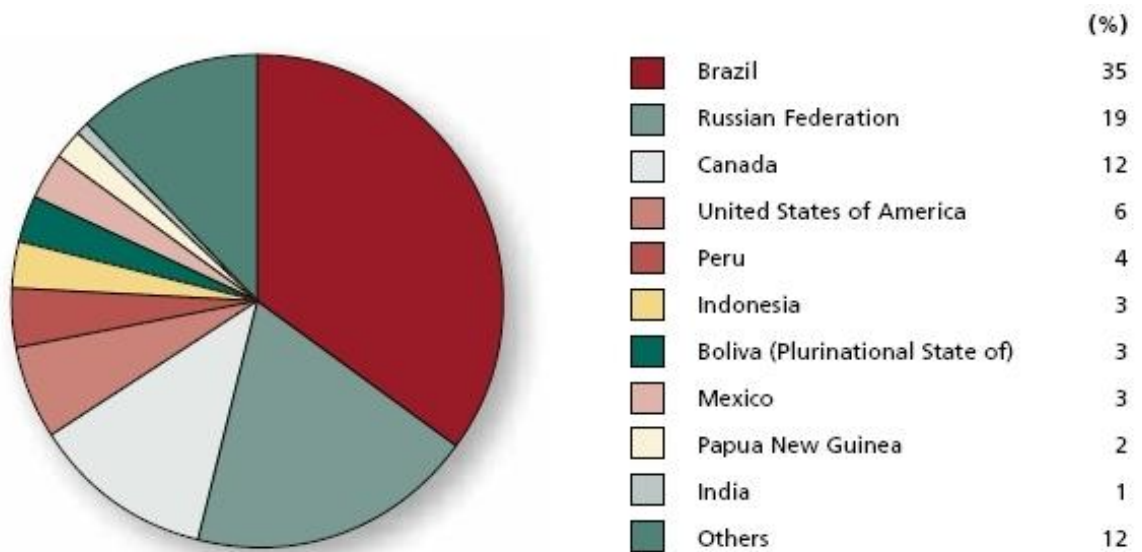

**Figure 5. The world's forests (Source: Global Forest Resources Assessment 2005:15)**

Although Brazil holds the world's second largest forest area, its plantations are relatively small accounting for only 6,782,500 hectares of planted forests, including Pine, Eucalyptus and other commercial species (ABRAF 2010). Thus Brazil occupies the 7<sup>th</sup> position among the ten countries with the greatest annual increase in planted forest area (Figure 7). In 1960 the Brazilian legislation created policies to stimulate the expansion of planted forests thus facilitating the growth of wood supply and stimulating large industrial enterprises in restoring its feedstock forests with the planting of new areas. As a result of these policies Brazil had about six million hectares reforested in the period of 1967 to 1986. This enabled the expansion of the Brazilian forest industry, as the country was able to supply quality raw material at a very low cost. (Buainain and Batalha 2007).

There are 400 different types of hardwood and Brazil's forests account for 35 % of the world's tropical timber reserves. Most of the production in Brazil is divided between the pulp and paper production and the sawn timber. Pulp and paper industry utilizes softwood, mainly Paraná Pine and Eucalyptus which plantations are located in the south of Brazil.

(Brazil Business Intelligence Report 2005). Brazil has expanded its presence globally due to its forest assets and the dynamic capacity of its industry. Brazil has achieved significant technological advances in the field of forestry and biotechnology. (SBS 2008, Embrapa 2012). High productivity from planted forests in Brazil was achieved due to improvements of seeds or clone plantations (SBS 2008) These planted forests have a better capacity of adaptation and tolerance to adverse soil, water and climate (ABRAF 2010).

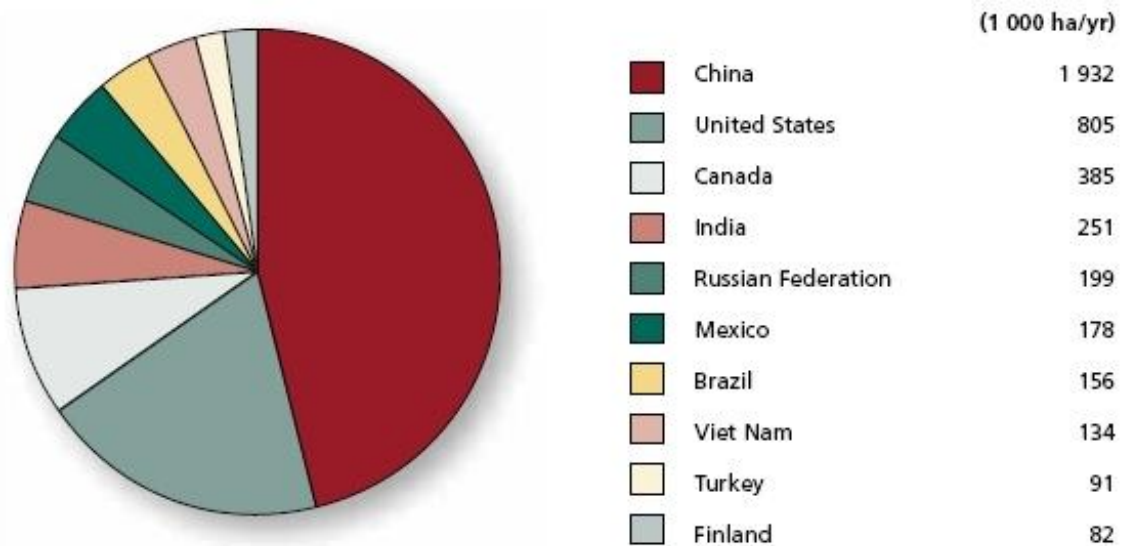

**Figure 6. Countries with the largest area of primary forest (Source: Global Forest Resources - Assessment 2010:53)**

**Table 1. Main bio-physical and forest indicators in Brazil (Source: Cross-Sectoral Policy Impacts Between Forestry and Other Sectors 2003:48)**

Surface area	845.6 million hectares
Forest cover	543.9 million hectares
% of land area	64.3 %
Forest area per capita	3.2 hectares
Deforestation (annual change 1990-2000)	-0.4 %
Average growing stock	131 cm/ha
Removals	235.4 million cm
Import	1.003 million US \$
Export	3.218 million US \$



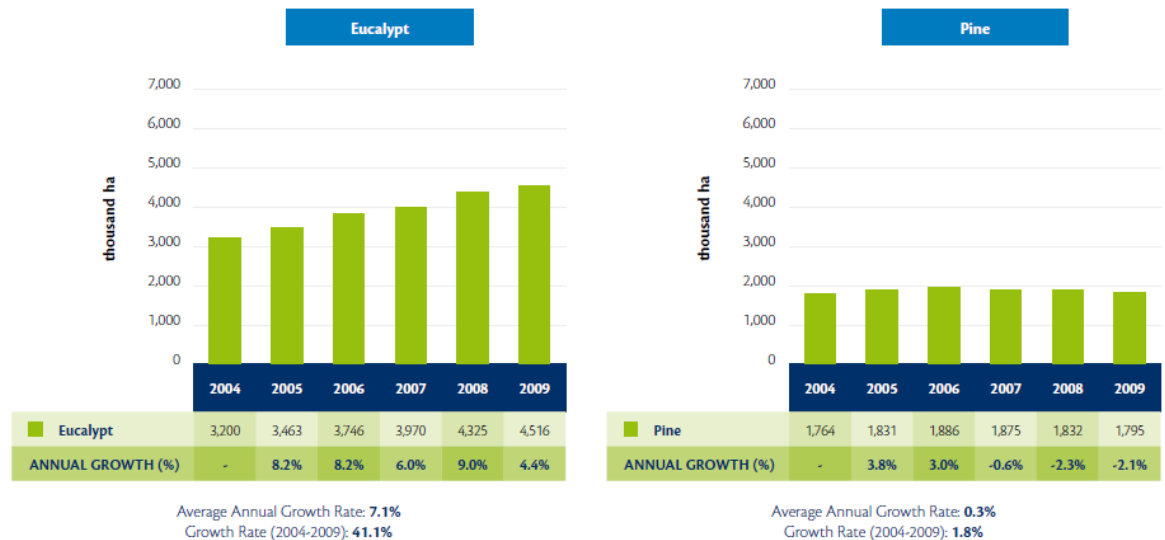

**Figure 7. Countries with greatest annual increase in planted forest area, 1990-2010 (Source: Global Forest Resources - Assessment 2010:94)**

In 2009 the total planted forest area of Eucalyptus and Pine in Brazil was 6,310,450 hectares (Figure 8). This number shows an increase of 2.5 % over the previous year. However, the last three years showed an annual growth of planted forests in Brazil in the order of 5.5 %, but due to the international financial crisis there was a reduction in the external market demand. In 2010 there was an increase of 152,700 hectares of planted forests in relation to 2009 due to a growth of 4.4 % of Eucalyptus planted areas. There was an expansion of over 1 million hectares of Eucalyptus planted areas over the past five years while Pine planted forests remained stable. The reason for the faster expansion of Eucalyptus is due to its rapid growth in short rotation cycle, high productivity and expansion and new investments of companies, especially from the pulp and paper segment. Some companies in Brazil decided to replace gradually their Pine forests by Eucalyptus or other crops which explain the decrease of 2.1 % of Pine planted areas in 2009 (Figure 9). The global financial crisis affected the increase of Pine planted areas as this species is directly associated with the timber industry which was facing a reduction in the production and exports. (ABRAF 2010)

The southern region of Brazil has the largest Pine planted forest areas representing 79 % of total planted Pine area in Brazil while the southeast region accounts for 56 % of

Eucalyptus planted forest areas (Figures 10-11). Most of these planted areas are destined to pulp and paper production. (ABRAF 2010).



**Figure 8. Evolution of forest area planted with Pine and Eucalyptus from 2004 to 2009 (Source: ABRAF 2010:21)**

In the case of Eucalyptus the charcoal-based iron and steel industry represents the segment with the second largest share with 20 % of forests, reconstituted wood-based panels with 6 % and 2 % for independent forest producers segment. The Pine forest is distributed 71 % for the pulp and paper industry, followed by segments of reconstituted wood-based panels and independent producers, with participation of 10 % each, and the iron industry with 9 % of the total. (ABRAF 2010).

The plantations of *Acacia mangium* and *Acacia mearnsii* (wattle group) species are concentrated in the states of Rio Grande do Sul and Roraima. In Rio Grande do Sul *Acacia mearnsii* is important to small forest producers which use this specie as a byproduct for fuelwood and for the extraction of tannin from the bark for companies in the business segment of tannin. In turn, *Acacia mangium* is recommended for industrial purposes and for recovery of degraded areas. The production of this species has the objective to meet both the domestic demand and international demand. The *Acacia* wood is destined to the production of firewood, coal and the export of wood chips for pulp mainly in Japan. The tannin of this species is utilized in the domestic market which supplies the sectors of

tanning, adhesives, oil, and rubber, among others. In addition, part of the production is exported to over 50 countries. It is noteworthy that the only producers and exporters of tannin are South Africa, Brazil, Chile and China. In 2009, wattle planted areas in Brazil totaled 174.150 hectares. (ABRAF 2010).



**Figure 9. Distribution of planted forests in Brazil in 2009 (Source: ABRAF 2010:29)**

Rubber tree (*Hevea brasiliensis*) originally from the Amazon rainforest is cultivated in extractive reserves or in commercial plantations to produce latex, natural rubber, while the wood upon the renewal of the planted rubber forest can be used for energy production or in the furniture industry.

Paricá (*Schizolobium amazonicum*) has its plantations concentrated in the states of Pará and Maranhão. This species occurs naturally in Brazil, Bolivia, Colombia, Ecuador, Honduras and Peru. Paricá has multiple purposes and is suitable for the manufacture of veneer, plywood, furniture and frames in general. It is also a potential timber in pulp production due to its excellent performance. The planted paricá area in Brazil is of 85,320 hectares in 2009 representing an increase of 6.4 % over the previous year (ABRAF 2010).

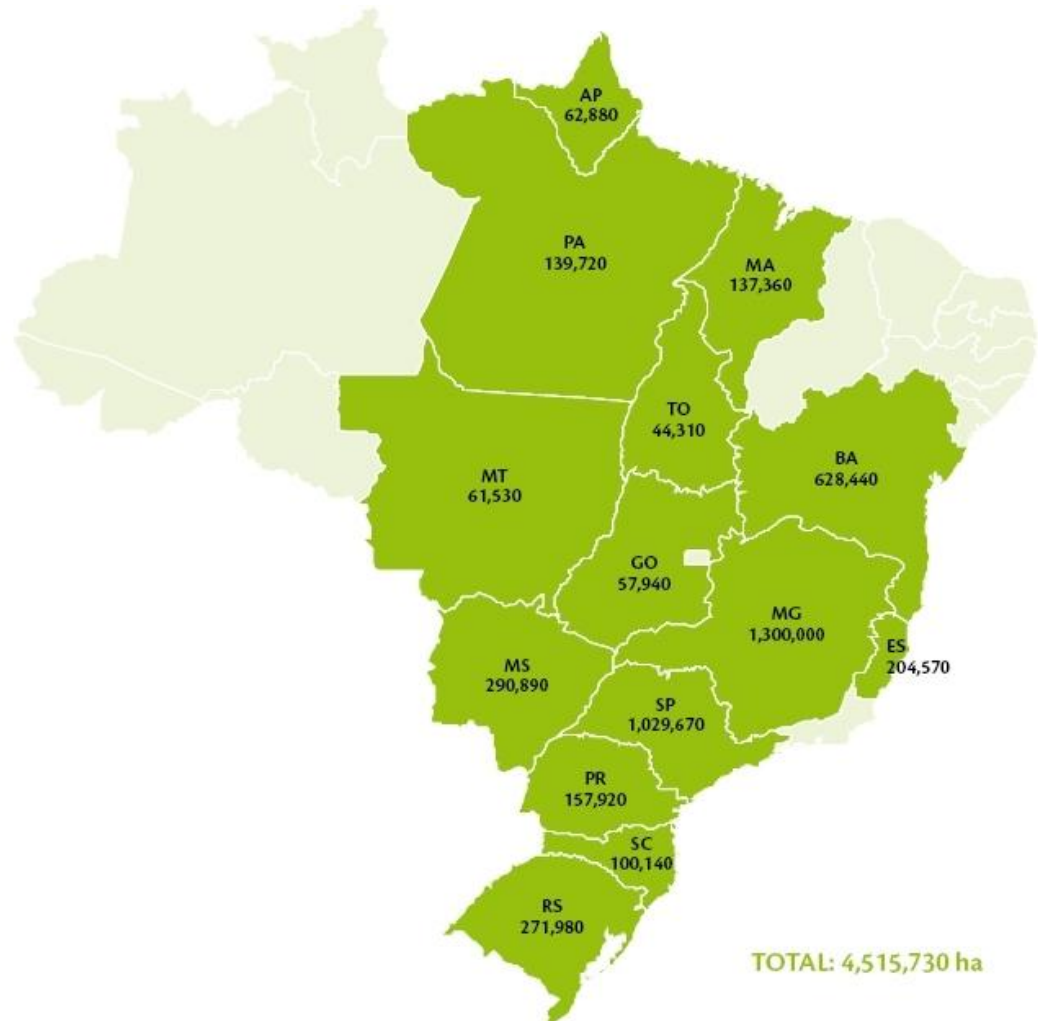

**Figure 10. Distribution of Eucalyptus planted forests in Brazil in 2009 (Source: ABRAF 2010:27)**

Teak (*Tectona grandis*) is a large tree with high adaptability. Forest plantations can be found mainly in the states of Mato Grosso, Amazonas and Acre. It is one of the most valued woods in the international market what explains the increase in their crops. Teak can be used for multiple purposes, such as civil construction, floorings and decks, furniture

industry, shipbuilding, decorative veneer, decoration and ornaments in general. Teak planted area in Brazil in 2009 was 65,240 hectares representing a 10 % growth compared to 2008 (ABRAF 2010).

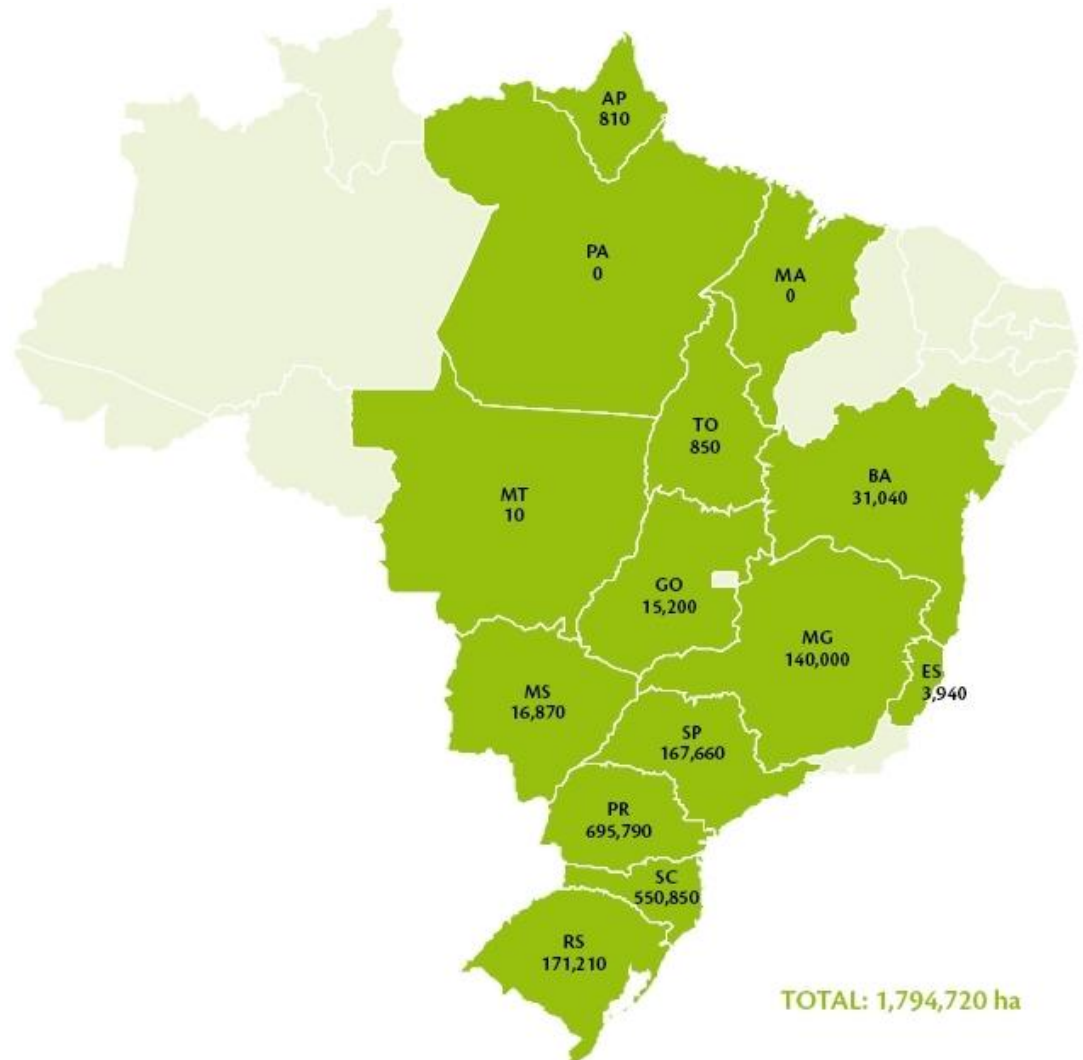

**Figure 11. Distribution of Pine planted forests in Brazil in 2009 (Source: ABRAF 2010:28)**

Parana Pine (*Araucaria angustifolia*) is a tree species originated from sub-tropical climate, which grows in the states of Paraná, Santa Catarina, Rio Grande do Sul, São Paulo and Minas Gerais. Parana Pine planted forests are located mainly in the state of Paraná and Santa Catarina. This high quality wood is used for sawnwood, veneer, solid wood products, furniture industry, general carpentry and in the paper industry. There was a reduction in the plantation area of Parana Pine in the south of Brazil due to the competition

with other fast growing species (Pine and Eucalyptus) and legal restrictions imposed for the preservation of this species. (ABRAF 2010).

Poplar (*Populus* spp.) is a fast-growing species used in the manufacturing of matches and in the furniture industry. Poplar forest plantations are located in the south of Brazil totaling 4,030 hectares. (ABRAF 2010).

Brazil has the 2<sup>nd</sup> largest certified forest area in tropical countries after Australia (Figure 12). Brazilian standard systems are approved for certification of tropical forests and have already been endorsed by PEFC (Forest Products Annual Market Review 2009-2010).

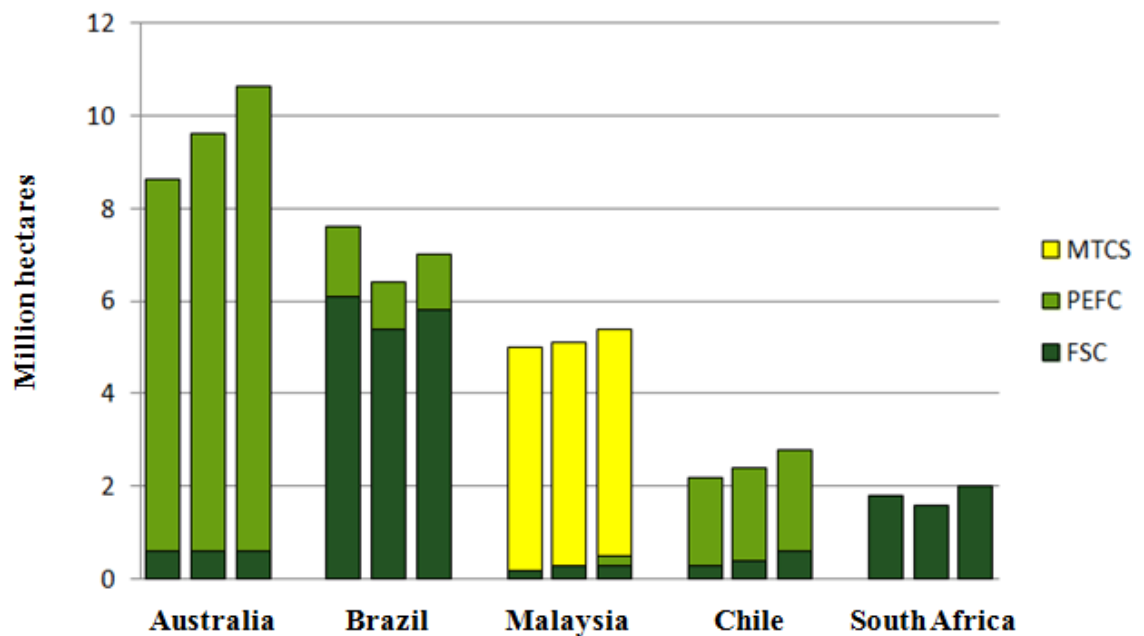

**Figure 12. Certified forest area in five countries. FSC, PEFC and MTCS are different forest certification systems (Source: Forest Products Annual Market Review 2009-2010)**

### 2.3.3 Forest productivity

Environmental conditions and the use of new technologies are important ways to increase forest productivity in Brazil. Research developments in the genetic of seeds and cloning are improving Brazilian forest productivity. (Brazilian forests at a glance 2009). Besides

high productivity, Brazilian technological development increased raw materials quality and optimized lignin content, pulp yield, wood density, calorific value, ash content and other characteristics. Development took place also in industrial output and final product uniformity, industrial installations, equipments and industrial processes. (ABRAF 2010). High productivity, growing demand and the need to cut costs were fundamental for the mechanization of forestry operations in Brazil (Simões 2008).

In Brazil Eucalyptus trees are ready for cutting at the age of about seven years, while in temperate climates, such as Finland, it can take up to 40 years. More detailed numbers about productivities of different hardwood and softwood species in different countries can be found in tables 2 and 3. (Fatos e Números do Brasil Florestal 2008).

#### **2.3.4 Industrial forestry sector in Brazil**

There are two models of industry organization present in the Brazilian forestry market. One is the pulp and paper, wood planks, hardboard and plywood industry which are dominated by few large companies. The other model is composed by a large number of small and medium-sized timber and furniture companies. Foreign companies have incorporated forestry sustainable management techniques through their subsidiaries in Brazil since 1980. The pulp and paper market is highly capital intensive with long term investments. The Brazilian pulp is produced entirely from planted forests, especially Eucalyptus and Pine. Large amount of investments were made in the sector thus making Brazil the world's largest producer of short fiber wood pulp. This sector developed over the years a sophisticated production structure which integrates suppliers, intermediaries and consumers (Figure 13). The production chain based on the forestry sector is a complex economic activity composed of different products and applications for the industrial and energy sector. The forestry sector has an important role as the supplier of energy and raw materials for the construction and processing industry. (ABRAF 2010). Through the years Brazil has developed a complex production structure in the forestry sector thus taking advantage of its large forested areas which are of great importance economically (Buainain and Batalha 2007).

The area of planted forests (0.7 % of total land area) is small, which clearly shows that planted forests expansion has favorable conditions to grow without interfering the national

production of food and other agricultural products. However, even occupying a small percentage of agricultural land, the forestry sector was responsible for generate 4,695,422 jobs in 2010. The sector contributed to R\$ 4, 41 billion in collected taxes representing 0.57 % of the total taxes collected in Brazil. In 2011the exports of products originated from forest plantations totaled US\$ 7, 53 billion. In 2007 the forestry sector was responsible for 3.4 % of the Brazilian GDP (gross domestic product) (US\$ 44, 6 billion) with the three strongest sectors: pulp and paper, steel and furniture (Reis and Filho 2011).

**Table 2. Hardwood Productivity in Brazil and selected countries (Source: Fatos e Números do Brasil Florestal 2008:39)**

Hardwood	Country	Age (years)	m <sup>3</sup> /ha.year
<b>Eucalyptus</b>	Brazil	7	35-55
<b>Eucalyptus</b>	South Africa	8-10	20
<b>Eucalyptus</b>	Chile	10-12	30
<b>Eucalyptus</b>	Portugal	12-15	12
<b>Eucalyptus</b>	Spain	12-15	10
<b>Birch</b>	Sweden	35-40	5,5
<b>Birch</b>	Finland	35-40	4

**Table 3. Softwood Productivity in Brazil and selected countries (Source: Fatos e Números do Brasil Florestal 2008:40)**

Softwood	Country	Age (years)	m <sup>3</sup> /ha.year
<b>Pinus spp</b>	Brazil	15	30
<b>Pinus radiata</b>	Chile	25	22
<b>Pinus radiata</b>	New Zealand	25	22
<b>Pinus elliotti/taeda</b>	USA	25	10
<b>Oregon Pine</b>	Canada (coast)	45	7
<b>Picea abies</b>	Sweden	70-80	4
<b>Picea abies</b>	Finland	70-80	3,6
<b>Picea glauca</b>	Canada	55	2,5
<b>Picea mariana</b>	Canada (east)	90	2



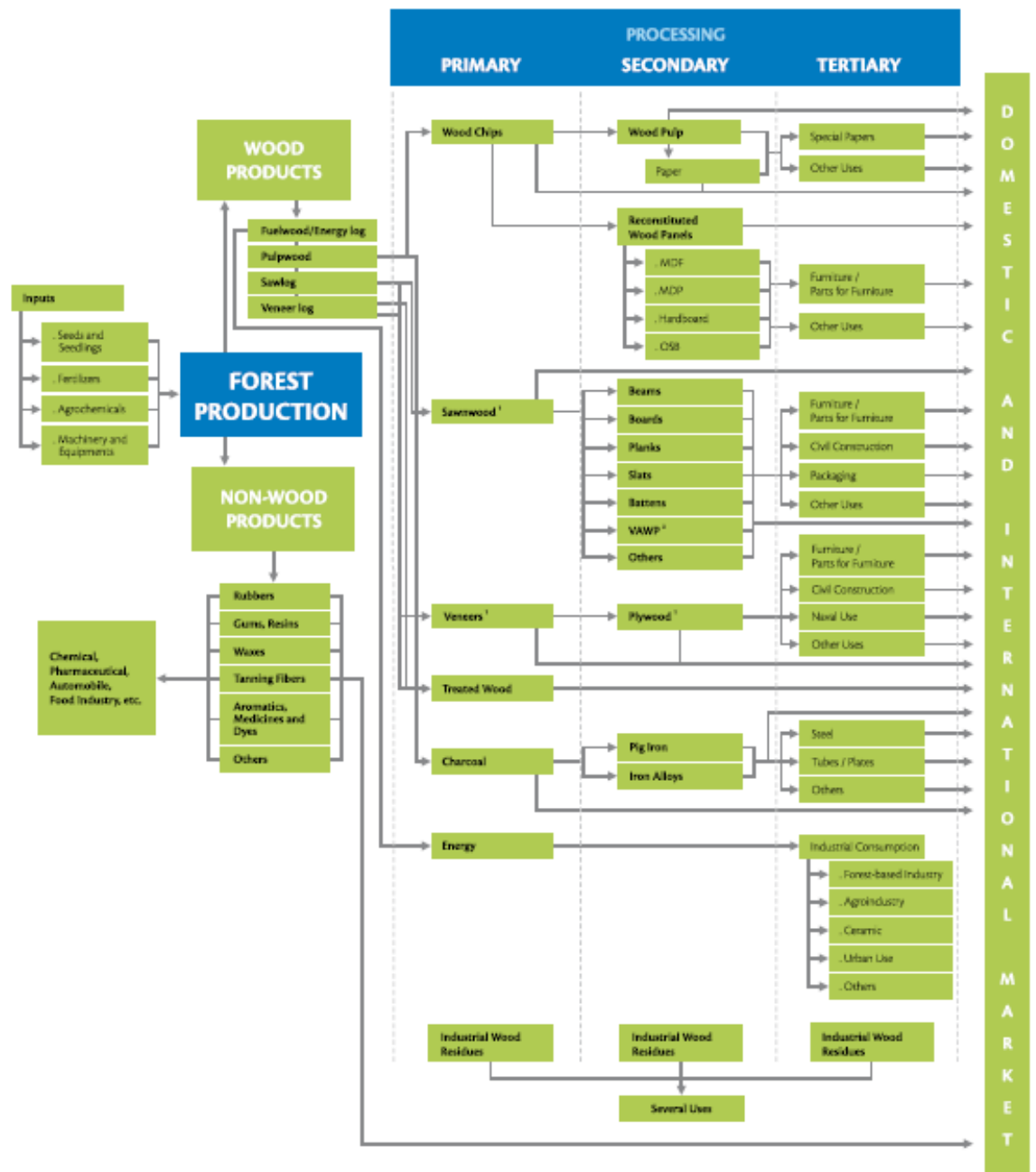

**Figure 13. Brazilian wood and non-wood production chain flowchart (Source: ABRAF 2010)**

Brazil has a well-established wood production. Forest activities are concentrated both in the North of the country with the production being mainly based in extractivism, and the South where the planted forests are dominant. The majority of the planted forests in Brazil are dedicated at the pulp and paper industry, timber and logs production. These forests are mainly constituted of Pine and Eucalyptus. (Walter and Dolzan 2009). In the north region

the wood industry explores mainly native wood whereas the activities in the south are based in planted forest with fast growing species.

Wood production in Brazil based on planted forests mostly takes place in the southern part of the country in the states of Minas Gerais, São Paulo and Paraná. Brazil has one of the best technologies worldwide for implementing dedicated forests of Eucalyptus. Adequate techniques are being applied to these plantations in order to avoid soil drainage, soil degradation, nutrient leaching and reduction of water storage capacity. The expansion of the forestry sector in Brazil occupies land previously used for other activities, mainly pasturelands. Among these lands are the “second-class” lands with poor chemical and physical characteristics, high slopes and lands under degradation stage. Orange and coffee fields are also shifting its use to forest plantations when both soil and topography loose quality. In the season of 2006-2007 alone, the additional area planted with forests was about 0.6 million hectares (Walter and Dolzan 2009).

The large investments made by the Brazilian government in the 1970's prepared a forestry infrastructure based on low cost and high productivity. Continuous development in forestry productivity gave Brazil the advantage of low production costs when compared to developed countries. (Buainain and Batalha 2007). Brazilian forests are important for the country's economy since they provide goods and services. Additionally the forests represent important social and environmental functions. Forests produce wood products such as firewood, charcoal, timber and also non-timber products such as leaves, roots, gums, fruits and environmental services. These products are either processed by the industries or sold directly to the final customer. (Brazilian forests at a glance 2009)

### **2.3.5 Tropical timber production in Brazil**

The output of tropical timber in logs between 2007 and 2009 remained stable at 140 million m<sup>3</sup>. The majority of this volume (about 75 %) came from the four major producer countries: Indonesia, Brazil, India and Malaysia. The following paragraphs give an overview about the Brazilian tropical timber market with attention to roundwood, sawnwood and plywood.

Roundwood production in Brazil is concentrated in the northern states of Pará, Amazonas and Mato Grosso. Production is relatively stable at around 24 million m<sup>3</sup> in 2007 (Figure 14) and 2008 with strong domestic demand although this number can be higher if considered the unrecorded illegal harvests. Brazil consumes all of its roundwood production from planted forests. In 2009 the consumption of roundwood from planted forests was 162, 6 million m<sup>3</sup>. (Forest Products Annual Market Review 2009-2010)

According to International Tropical Timber Organization, Latin America accounted for 44 % of the total tropical sawnwood produced in the world. There was a growth of 6 % between 2007 and 2008 to 18,5 million m<sup>3</sup> (Figure 14). This number is expected to remain stable due to the economic growth and strong construction sector in Brazil. (Forest Products Annual Market Review 2009-2010)

The tropical plywood production in Brazil has declined in recent years from 1.4 million m<sup>3</sup> in 2004 to 599.000 m<sup>3</sup> in 2008 (Figure 14). The reason for this decrease can be explained by the strengthening of the Brazilian currency (Real) in relation to the US Dollar which made exports to the United States and EU more expensive. Also the competition in export markets from Asian producers, in particular China and Malaysia. Major markets for Brazilian sawnwood in 2008 were China, France, The Netherlands and the United States. Despite the decrease in exports of tropical sawnwood, Brazil's domestic demand has grown. The country is the third largest tropical sawnwood exporter, with exports totaling 1 million m<sup>3</sup> in 2008. (Forest Products Annual Market Review 2009-2010)

### **2.3.6 Energy forests in Brazil**

Wood is still being widely used as a source of energy and heat around the world. Few energy sources can be as economic as wood. (Buainain and Batalha 2007). Energy forests are defined as forest plantations with fast growing species which have the objective of producing higher amount of biomass per unit area in shorter cycles. These plantations are characterized by high density and small diameter trees. (Short Rotation Crops for Bioenergy Systems 2008). Energy forests can additionally enhance the development of rural areas and generate jobs in Brazil. (The Bioenergy, Food and Water Nexus: Developing Country Perspectives 2011). The Eucalyptus is the most utilized species for energy purposes in Brazil followed by Pine and Acacia due to their rapid growth. Fast

growing species are used due to its short rotation. (Neutzling and Palmeira 2007). Brazil can take advantage of its energy forests due to its land availability, suitable climate, skilled labor and business corporations interested in making investments.

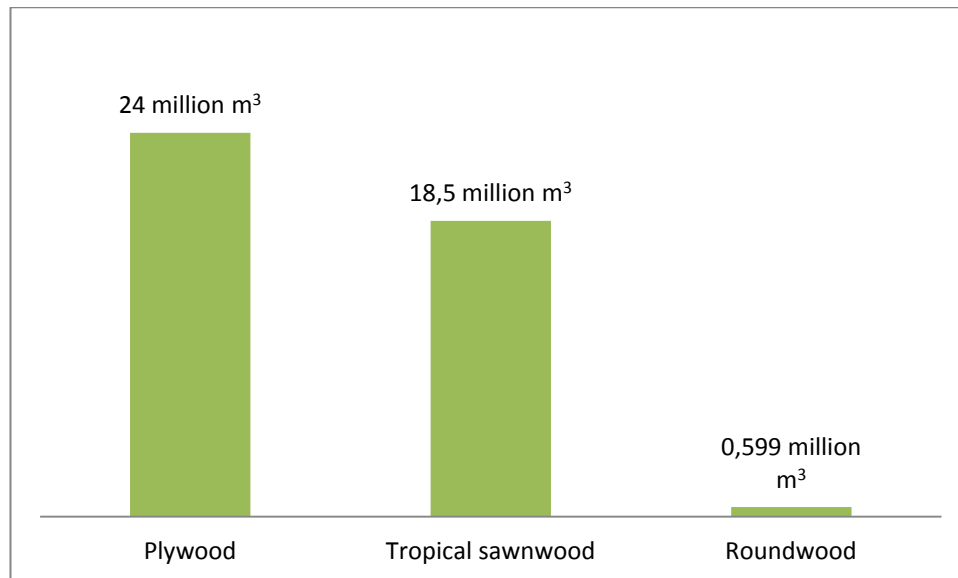

**Figure 14. Tropical timber production in Brazil 2008 (Source: Forest Products Annual Market Review 2009-2010)**

Brazil has been exploring wood for energy production in large scale for many years. Wood for charcoal was extensively used in order to feed the steel industry. At present forest plantations with fast growing species to produce biomass for generation of heat and electricity are receiving significant investments. (Broadhead 2008). In 2007 the total energy consumption of wood products in Brazil was estimated at 1,198 PJ (petajoules) with residential and industrial sectors being the most important consumers (Walter and Dolzan 2009).

Special attention should be given to the use of plantations with fast-growing trees with repeated cycles as the continuous harvesting of these plantations can exhaust the soil from key nutrients. The utilization of native forests and grasslands for these plantations should be also monitored in order to preserve the natural biodiversity. (Miller and Spoolman 2009). Brazil has about 90 million hectares of arable land which are not utilized and 60 million hectares of pastures which could be converted into energy plantations in short-

term. (SBS 2006). The country has important competitive advantage such as a developed forest industry and unmatched production costs (Macedo 2001). The industries have the most significant consumption of residues, especially the pulp and paper sector. In the sector of food and beverage and in the sector of ceramic the consumption of firewood is higher. (Walter and Dolzan 2009).

It is important for Brazil to keep developing advantages of its high productivity plantations and harvesting methods in order to produce biomass at competitive costs in the energy market. Development of tree cloning, advanced forestry technology, plantations management, harvesting, transportation and energy conversion are important determinants to maintain Brazil as an important biomass producer. Additionally, clear and consistent policies, laws and practice guidelines can structure all the aspects of investments in forest plantations. Brazil has already made investments in technological research and development to turn wood energy plantations into an attractive business. A great advantage for Brazil is that the country can be flexible when it comes to energy price fluctuations. Brazil has a developed forest industry capable of adapting forest biomass for other uses. For example, wood pulp and reconstituted wood panels industries use the same raw materials, thus reducing the risk of investment in energy crop plantations. (Broadhead 2008)

### **2.3.7 Wood loss in forest production chain**

Along the process of harvesting and processing wood into manufactured goods a number of residues and waste are generated. (Figures 15 and 16) This excess can be classified as waste of forest management and silvicultural treatments such as thinning, clearing and pruning. (Fagundes 2003). In tropical forests the volume of waste left from harvesting operations is three to six times that generated at mills. (Broadhead 2008). Furniture manufacturers produce biomass waste through its production process. This waste is often consumed by the furniture plants and is rarely available for purchase by energy users. Furniture residues are typically dryer and dustier than green wood waste. (Maker 2004). It is common practice to leave forest residues (such as twigs, branches, tree tops, broken pieces and logs) produced by harvesting operations in the forest. These residues have not reached minimum commercial value dimensions, which justifies its removal. (Broadhead 2008).

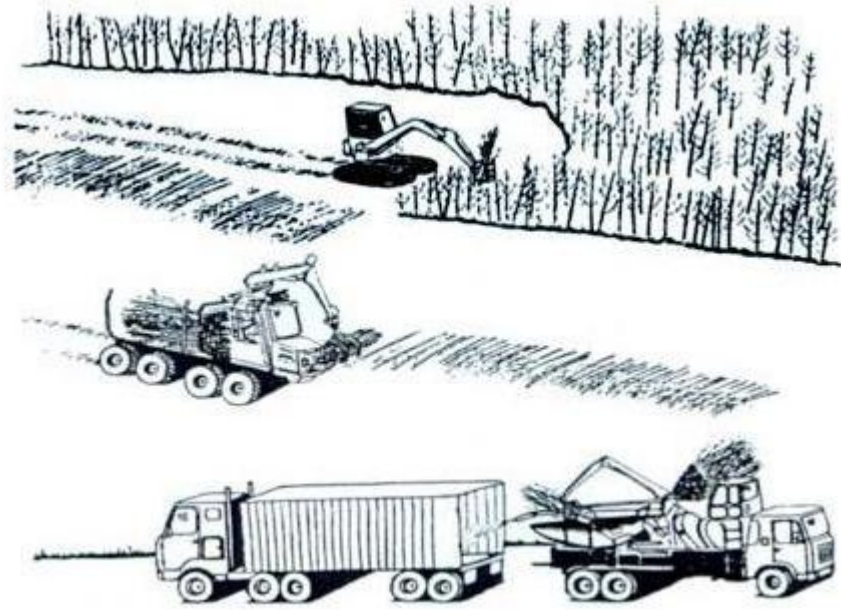

Figure 15. Biomass extraction from energy forests (Source: Martí 1999:53)

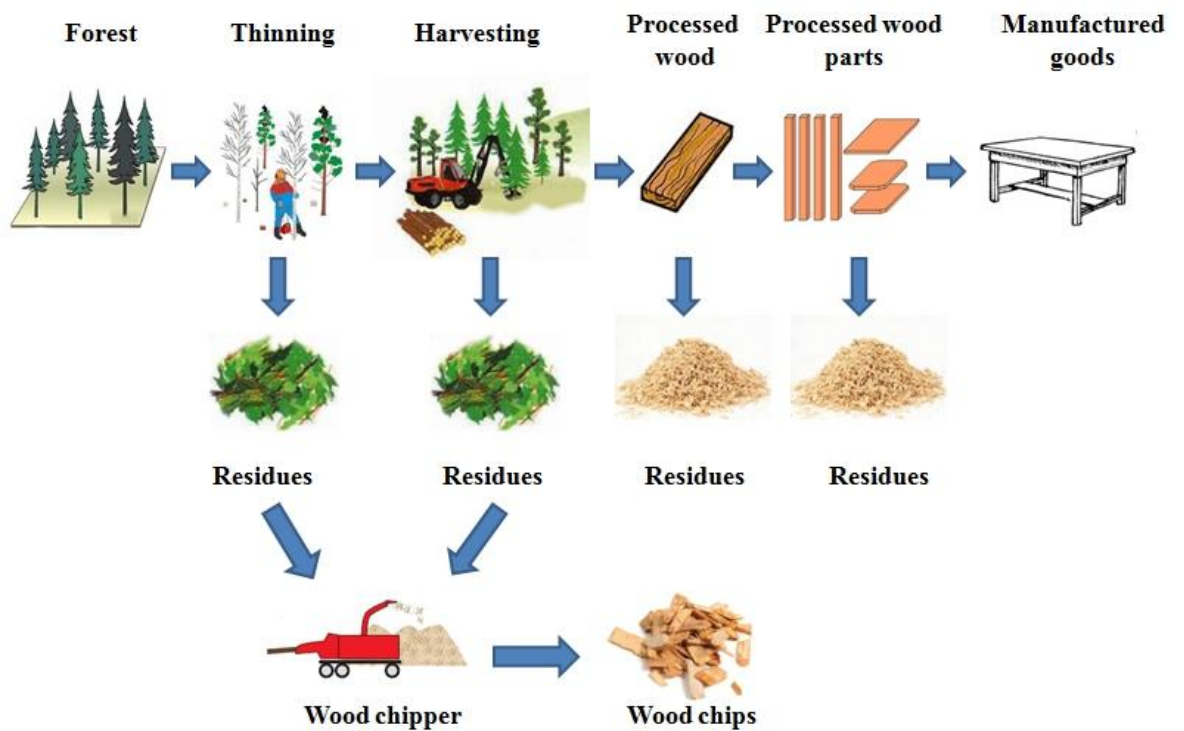
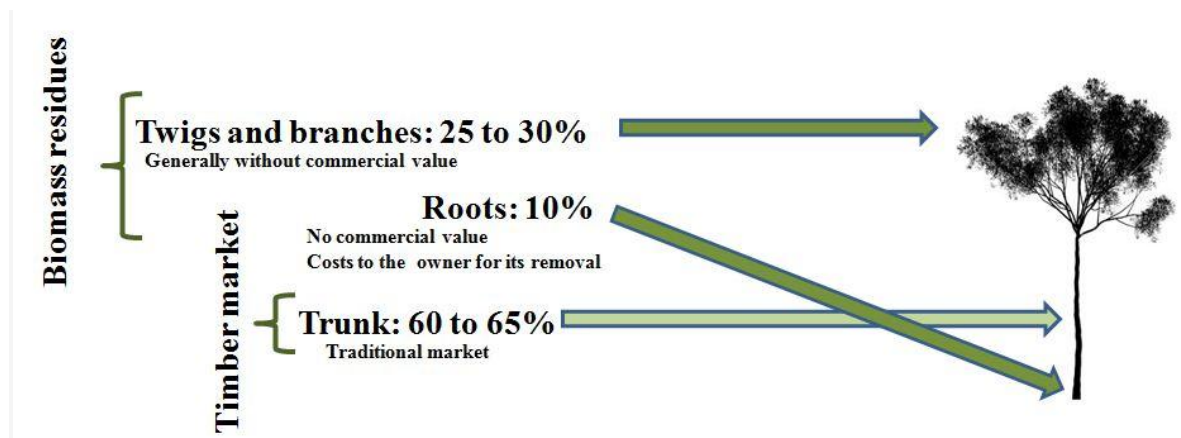

Figure 16. Wood residues chain in the forestry industry (Source: Paula 2006)

Less than two thirds of a tree is removed for commercialization during the harvest. About 33 % of the tree mass is left in the forest. (Energy conservation in the mechanical forest industries 1990). Figure 17 shows the biomass distribution in a tree indicating that some parts are considered commercially valuable while others are waste. Although forest operations generate a large amount of biomass, it is common for many countries to lack awareness of its full potential for energy generation. In figure 18 is shown a comparison of wood residues left in the forest after harvesting operations in Brazil.



**Figure 17. Biomass distribution in a tree (Source: Santos 2008)**

Only a small portion of the tree is used for production while large percentages of residues are discharged during the process. (Forests and energy in developing countries 2007). A study made in Brazil showed that, the result of the harvest of *Eucalyptus grandis* logs with 6 cm diameter made with slingshot and forwarder, resulted in 16,167 m<sup>3</sup>/ha of wood residues corresponding to 4.51 % of the total harvested (Bauer 2001). According to another study (Jacovine 2001) made in the southeast of Brazil with Eucalyptus, 5.9 % of valuable wood is left in the forest after the harvest operation. This happens because of operational failures when the harvested logs do not meet the customer specification. According to FAO around 8 to 10 % of wood losses happen during harvest operations. (FAO 1990). Wood loss comes from cutting to the transport stage and represents an expressive amount. (Jacovine 2001). Besides, the use of fully mechanized systems has led to loss of wood during harvest operations. Log damages such as butt pull, log splitting, bucking and crushing can happen during the felling, delimiting, bucking, skidding, forwarding, pilling, loading and hauling. Volume losses can go up to 4.5 % when a shear head is utilized in the

harvest while 0.25 % when the head is equipped with a chainsaw. (Gerasimov and Seliverstov 2010). Major segments which generate wood residues include sawmills, pulp mills and furniture industries. It is common for micro, small and medium enterprises to sell generated residues while large enterprises make use of all residues internally for energy generation. (Felfli, Mesa, Rocha, Filippetto, Luengo and Pippo 2010).

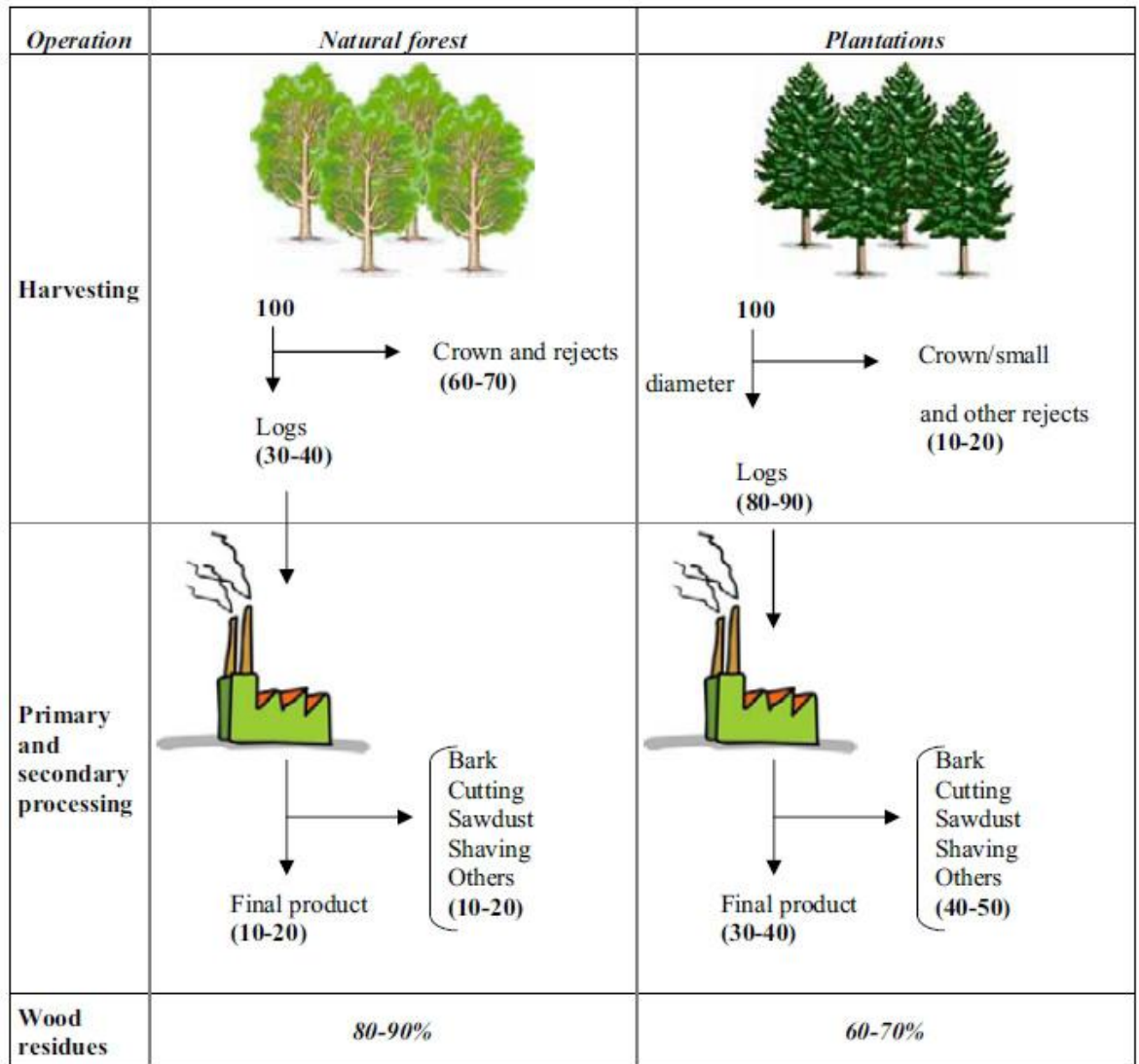

**Figure 18. Forest industry operations and wood residues (Source: Forests and Energy in Developing Countries 2007:22)**



### **2.3.8 Energy matrix and bioenergy production in Brazil**

Brazil is the largest energy consumer in South America, using 40 % of the total energy amount produced in the continent. The main energy supply consumed in the country is petroleum (37.9 %), followed by biomass (32 %), hydropower (15.2 %), natural gas (8.8 %), coal (4.8 %) and uranium (1.4 %). Hydropower accounts for 76 % of the domestic electricity supply followed by imports and biomass coming on third with 8.1 %. Other sources of energy such as oil products, natural gas, nuclear, coal and wind play a minor role. This shows that Brazil has a much diversified energy matrix and has a large proportion of renewable energies. (Schuber 2010)

Brazilian population growth and economic development will increase considerably the demand for energy. According to Energy Information Administration (EIA) the largest increases in energy demand will take place in developing countries. Furthermore, energy consumption is expected to grow at an average annual rate of 2.6 % from 2004 to 2030 in developing countries. Energy consumption in developing countries already surpassed industrialized regions and are expected to be by 2030 35 % greater than in OECD countries. About 50 % of the increase in energy demand in the world by 2030 will be for power generation while one fifth for transport needs. This increase will be the result of rapid economic growth of developing economies such as Brazil. (International Energy Outlook 2007)

Forest biomass needs to be processed before its use for power generation. Concentration of the residue material into high density unities facilitates not only its handling, storage and end usage but also lowering transport costs. Wood chippers are machines used for reducing forest biomass into smaller pieces like wood chips. (Martí, 2006). District heating systems produce both electricity and heat for urban areas utilizing wood chips. In the city of Joensuu (Finland) for example the district heating system produces approximately 260 GWh of electricity and 510 GWh of district heat per year. The main solid biomass utilized in the Joensuu power plant are wood and peat with wood representing more than a half of the fuel utilized. (Fortum 2011)

## 3 BIOMASS

### 3.1 Types of biomass

Biomass is any organic matter from animal or vegetable origin that can be used to produce energy (Silva, Garrafa, Navarenho, Gado and Yoshima 2005). Biomass is an indirect form of solar energy, as resulting from the conversion of solar energy into chemical energy through photosynthesis (Proinfa 2011). Biomass resources include forest and mill residues, agricultural crops and wastes, wood and wood wastes, animal wastes, livestock operation residues, aquatic plants, fast-growing trees and plants, and municipal and industrial wastes (Figure 19) (Biomass Combined Heat and Power Catalog of Technologies 2007). Biomass can further be divided into more specific terminology, with different terms for different end uses: heating, power generation or transportation. We tend to use the term 'bioenergy' for biomass energy systems that produce heat and/or electricity and 'biofuels' for liquid fuels for transportation. (IEA International Energy Agency 2011)

The amount of biomass on earth is estimated to be two trillion tons. In energy terms it corresponds to more than 3,000 EJ per year or eight times the world consumption of primary energy. (Atlas de Energia Elétrica do Brasil 2005). The leading woody biomass consuming countries by volume are regions with large areas of forests, including Brazil, Canada, Sweden and the United States (Forest Products Annual Market Review 2009-2010 2010). Solid biomass still largely used for heating and cooking in many countries accounting for 95 % of their energy needs. Developing countries utilize biomass for industrial processes and for generating electricity accounts for 35 % of their energy use. (Miller and Spoolman 2009).

It is important to understand the concepts of biomass, forest biomass and forest residues. Biomass is all the material of biological origin that can be used either as a source of energy or other industrial purpose. Forest biomass is originated from the trees which can be consumed by the industry either as raw material for posterior transformation or as fuel and forest residues are the waste generated during the process of forest biomass in the industry. (Martí 2006)

There are three classes of biomass: solid, liquid and gaseous residues, of which only the first one is important for this study. Solid biomass comprehends renewable organic material such as municipal solid waste, sewage, animal waste, industrial residues, agricultural crops and residues, forestry crops and residues that can be used as fuel to produce heat or generate electricity (Figure 20). (Cushion, Whiteman and Dieterle 2010) According to IBAMA (2011) forest residues are waste materials which are not the main object of activity, resulted from the forest raw material alteration due to external action through mechanical, physical or chemical processes. Wood residues from pulp and paper manufacturing, lumber mills, and other industrial wood users are frequently used for producing biomass electricity. (ABIB 2011). Prices of smaller logs and forest management are being affected by the growing use of biomass. There is an increasing utilization not only by the forest industry but by the residential energy sector as well. (Forest Products Annual Market Review 2009-2010 2010).

Sources of solid biomass are listed below:

- *Forest operations*: Branches, needles, leaves, stumps, roots, low grade and decayed wood, slashing and sawdust;
- *Logging residues*: Tree tops, small stems, roots and broken debris from logging operations.
- *Sawmilling residues*: Bark, sawdust, trimmings, split wood, planer shavings, sanderdust;
- *Plywood residues*: Bark, core, sawdust, lily pads, veneer clippings and waste, panel trim, sander dust;
- *Particleboard residues*: Bark, screening fines, panel trim, sawdust, sander dust. (Energy conservation in the mechanical forest industries 1990).

### **3.2 Use of biomass in Brazil**

Biomass is one of the sources for energy production with the greatest potential for growth in Brazil. It is considered one of the main alternatives to diversify sources of energy and consequently reduce its dependence on fossil fuels. Forest biomass could attend the urban, rural and industrial demand. (Oliveira 2011). High quantities of wood are available in

Brazil indicating a good potential for electricity generation capacity for that demand. (Table 4).

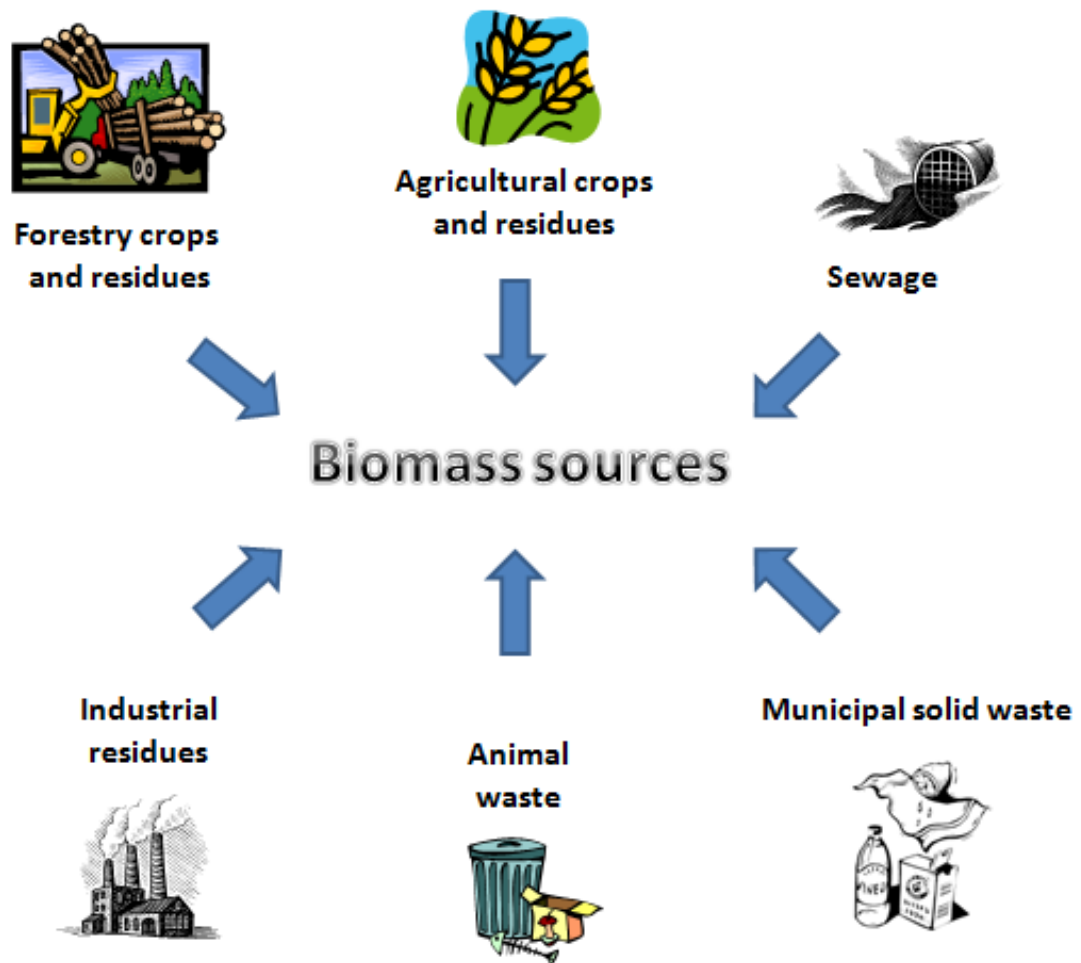

**Figure 19. Solid Biomass Sources (Source: Cushion, Whiteman and Dieterle 2010)**

Brazil is mainly an agricultural country which generates about 330 millions of metric tons of biomass each year. (Felfli et al. 2010). Brazil offers favorable climatic conditions and a great availability of land for the cultivation of energy crops. (Abreu, Oliveira and Guerra 2010) Additionally, low cost of labour and good knowledge of biomass production and conversion technologies are other advantages that Brazil has. (Walter et al. 2006). Brazil's forest biomass is generally composed of:

- Waste left on the field from harvest operations
- Waste from industries that use wood as raw material
- Waste from native forest harvested for giving space for agriculture, pasture, reforestation, etc. (ABRAF 2011)

**Table 4. Quantity of wood biomass in Brazil (Source: World Energy Council 2010)**

Quantity of raw material available	92.61 million tons
Solid fuel production capacity	295 000 TJ/year
Yield of solid fuel	6.81 GJ/ton
Solid fuel production	264 574 TJ
Electricity generating capacity	148 481 kW
Electricity generation	3 015 TJ
Direct use from combustion	692 742 TJ
Total energy production	1 201 966 TJ

Wood, sugarcane and oil seeds are at the moment the predominant biomass resources in Brazil. The contribution of wood to the total energy supply in 2007 was 1183.46 PJ, or 12.8 % of the total. Brazil is already producing about 2 EJ of bioenergy per year thus being the fourth-largest bioenergy user after China, India and the United States. (Abreu et al. 2010). According to PNE 2030 Brazil can increase the actual  $30 \times 10^6$  tons/year biomass supply to  $46 \times 10^6$  tons/year in 2030 (Figure 20).

There are already many biomass fuel systems currently at work in Brazil heating schools, government buildings and town areas as well as generating electricity (Oliveira 2011). There are also a number of advantages for Brazil in utilizing wood residues for energy purposes, such as becoming more independent from oil imports and creating jobs in the bioenergy sector. It would be also beneficial for the country to achieve its environmental goals.

Advantages of biomass for energy production are:

- It's a source of clean and renewable energy that can be sustainably produced
- The residues produced by burning biomass do not interfere in the greenhouse effect
- Low implementation and maintenance costs
- It's a decentralized power source as it can be grown and harvested on local and regional forests and farms
- Decrease dependence on oil and its prices are generally lower and more stable
- Reduce garbage

- Reduce poverty
- Stimulates rural economic and infrastructure development
- Increase investment in land rehabilitation
- New revenues from the use of wood residues and carbon credits

Potential negative impacts are:

- Reduction of local food availability if the land is replaced for the growing of energy crops
- Higher demand for energy crops can lead to deforestation, reduction of biodiversity and increase greenhouse gas emissions
- Intense cultivation of bioenergy crops can lead to reduction of soil quality and fertility (Broadhead 2008)

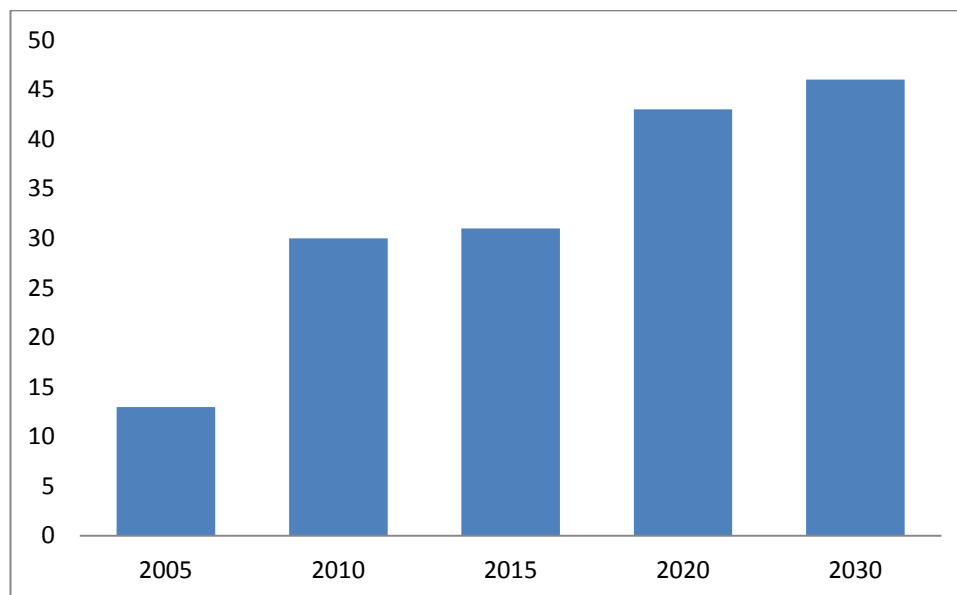

**Figure 20. Brazilian forestry biomass supply by mass (10<sup>6</sup> t/year) from energy forests (Source: Plano Nacional de Energia 2030 2007:89)**

Biomass can be used as fuel through combustion in furnaces and boilers. Advanced biomass conversion methods, such as gasification and pyrolysis, increase its efficiency. The share of biomass utilization in Brazil is of 30 % being most of it utilized in co-generation projects for supplying electricity to isolated areas of Brazil. The communities living in these isolated areas could also benefit from these projects developing sustainable

extractive activities which can contribute for the development of these same communities. (Atlas de Energia Elétrica do Brasil 2005)

### **3.3 Bioenergy and renewable energy sources in Brazil**

Bioenergy is used to describe biomass energy systems that produce heat or electricity. The term also refers to all types of energy derived from biofuels. Biofuels are fuels derived from biological sources and are used generally for transportation. (Loo and Koppejan 2008). At the moment bioenergy accounts for 14 % of the world energy consumption. It is estimated that in 20 years about 30 % of the energy consumed worldwide will be from bioenergy. (Celulose Online 2011). The effect of greenhouse gases to the environment due to the excessive use of fossil fuels brought great concern for seeking alternative and renewable energy sources. Vegetable oils can be a good alternative for biodiesel production. Brazil is well ahead in the production and research of *Jatropha curcas*, sunflower, soybean, castor bean, African Palm, babassu, cotton, peanut, linseed, macauba, pequi, buriti, sesame, canola and others. (Lopes and Neto 2011)

Brazil has made investments of US\$12.8 billion in 2008 and US\$7.8 billion in 2009 in renewable energy thus having one of the world's highest shares of renewable energy in electricity generation. Investments in renewable power-generation in Brazil account for 82 % of total investment in power generation plants while in the European Union are 71 % (WEO 2010). Biomass production costs are the lowest when compared to other energy sources in Brazil (Figure 21).

Brazil and China have the highest increase in demand for renewable energy for heat outside OECD countries. In Brazil the use of modern renewable energy for heat will increase from 36Mtoe in 2008 to 65Mtoe in 2035. According to World Energy Outlook 2010 Brazil remains the country with the largest share of renewable in total primary energy demand with 55 % of energy coming from modern renewable in 2035. (World Energy Outlook 2010)

Brazil has expressed strong concern in cutting emissions of greenhouse gases from forestry during the United Nations conference on climate change held in December 2009 in Copenhagen. The country committed to reduce 800 Mt of carbon dioxide from land use,

land use change and forestry. The commitment of developing countries in implementing funds for new clean energy technologies will be essential to the future of Biofuels technology. Brazil and China hold large biomass resources and well-developed infrastructure thus being key countries for this development. Brazil has been implementing supporting programmes with the purpose to attract significant investments in renewable energy sources. (World Energy Outlook 2010)

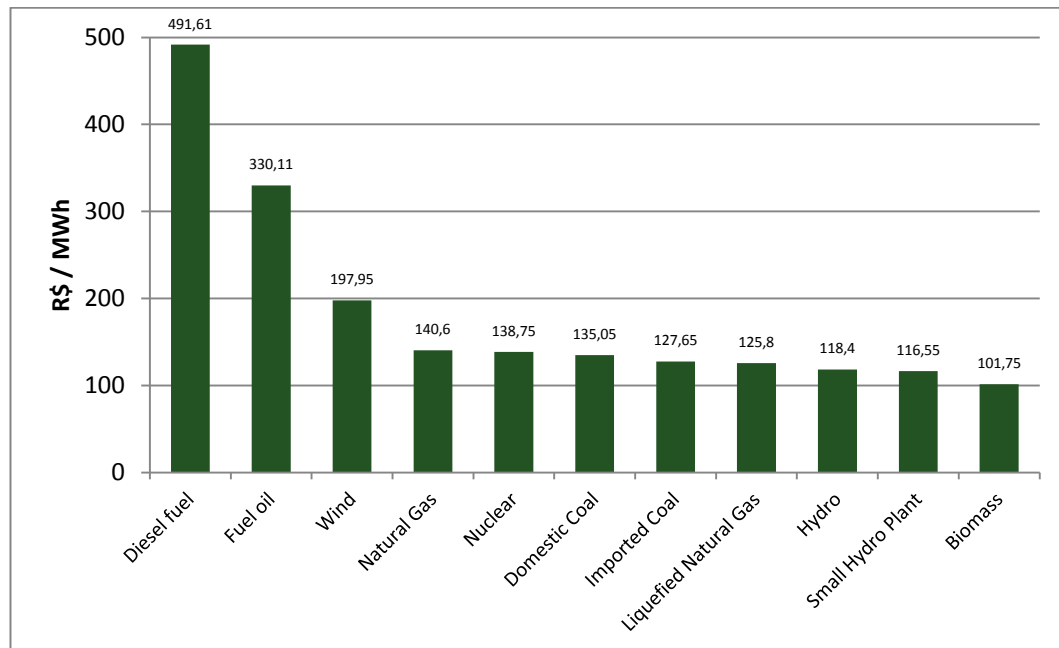

**Figure 21. Production costs of electricity in Brazil (Source: Atlas de Energia Elétrica do Brasil 2008:30)**

Brazil has suffered an energy crisis in 2001 when a decrease in rainfall affected the power capacity of hydroelectric power plants. This crisis brought up the vulnerability to depend strongly in one energy source and showed the need to diversify its energy matrix. (Abbud and Tancredi 2010). Thus the Brazilian government created the Empresa de Planejamento Energético (Energy Planning Company), the PROINFA (Incentive Program for Alternative Electric Energy Sources) and the Plano Nacional de Agroenergia (National Agro-Energy Plan) in order to research and develop new energy sources (Scandiffio 2004).

The PROINFA aimed to provide 3,300 MW of energy from renewable sources in its first phase and to meet 10 % of the annual consumption in 20 years. Renewable sources should



have an increase of 15 % annually in the total national energy supply in order to reach this objective. The purpose of PROINFA is to increase the participation of biomass, wind, solar and small hydropower plants offering special incentives for entrepreneurs. (PROINFA 2011). It is also important for Brazil to expand its energy matrix in order to decrease its dependence on fossil fuels and ensure energy supply without being susceptible to fluctuation of oil prices (COELHO 2005). Planted forests could be a good alternative for expanding the energy matrix lowering the risk of an energy crisis. Figure 22 points out the areas in Brazil with the largest potential for electric energy generation from planted forests. The use of biomass as a source of electricity has been increasing in Brazil in the industrial and service sectors. According to BEN 2008 biomass supplied 18 TWh which means 21 % higher than in 2006. In 2009 biomass corresponded to 5.4 % of the total domestic electricity supply being surpassed only by hydro and imports (Figure 23). (Atlas de energia elétrica do Brasil 2008). Power plants which are already using wood residues as fuel are concentrated mostly in the south region of Brazil (Figure 24). A more detailed list of the locations can be found as appendix 2.

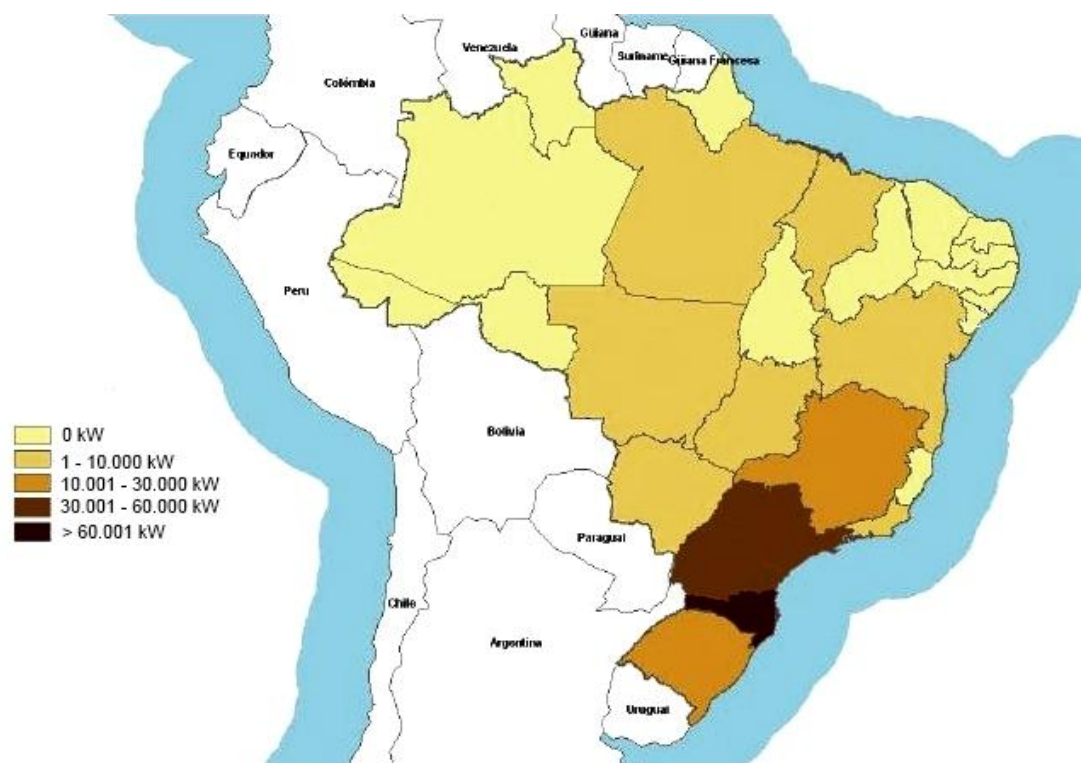

**Figure 22. Potential of electricity generation from planted forests in Brazil. (Source: Porto, 2007)**

Energy users prefer to use mill chips as they are more uniform, unless there is a significant price difference (Maker 2004). The reason is that uniform wood chips have a better distribution thus improving combustion properties. Additionally, wood chip size affects storage, ventilation, energy conversion, emissions and feeding fluency in the biomass fuel converter. (Hartmann, Böhm, Jensen, Temmerman, Rabier and Golser 2006).

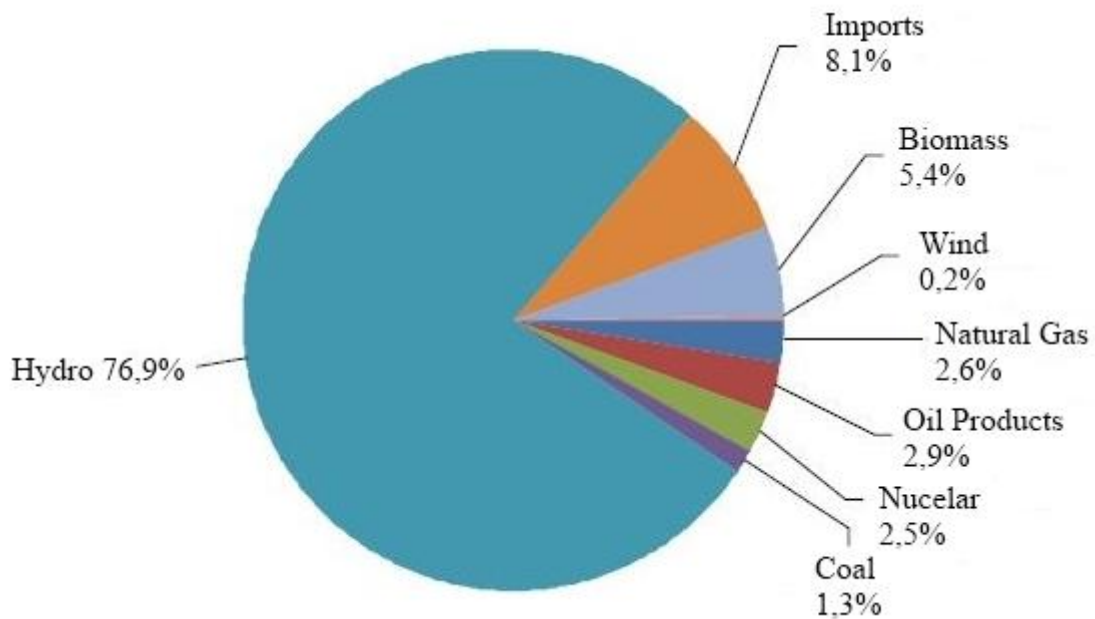

**Figure 23. Domestic Electricity Supply in Brazil by Source 2009 (Source: BEN 2010:12)**

According to the National Energy Plan 2030 (PNE 2030) the technologies available to be utilized in electric energy production are:

- *Steam turbines with back-pressure flow control:* Steam turbines are employed in production processes through co-generation. The steam can drive turbines used in mechanical work required in production and the turbines utilized in power generation. This process is currently the most widespread. Brazil has several domestic producers of most of the necessary equipment. (Plano Nacional de Energia 2030 2007)
- *Extraction condensing turbines:* In this system a condenser located at exhaust of the turbine will heat the cooling water inside the condenser utilizing steam that will feed the boiler. This system is more efficient in obtaining larger volumes of electric energy. However, its installation requires far greater investments if compared to the

steam turbines with back pressure flow control. (Plano Nacional de Energia 2030 2007)

- *Integrated biomass gasification combined cycle:* Gasification is the conversion of any liquid or solid fuel, such as biomass into energetic gas. This technology produces gas that can be utilized in thermal plants for electric power generation. Thus the gasification method applied in a larger scale transforms biomass in an important primary source for thermoelectric power generation. According to PNE 2030 the main obstacle for this application is to find reliable equipment capable to produce good quality gas. (Plano Nacional de Energia 2030 2007)

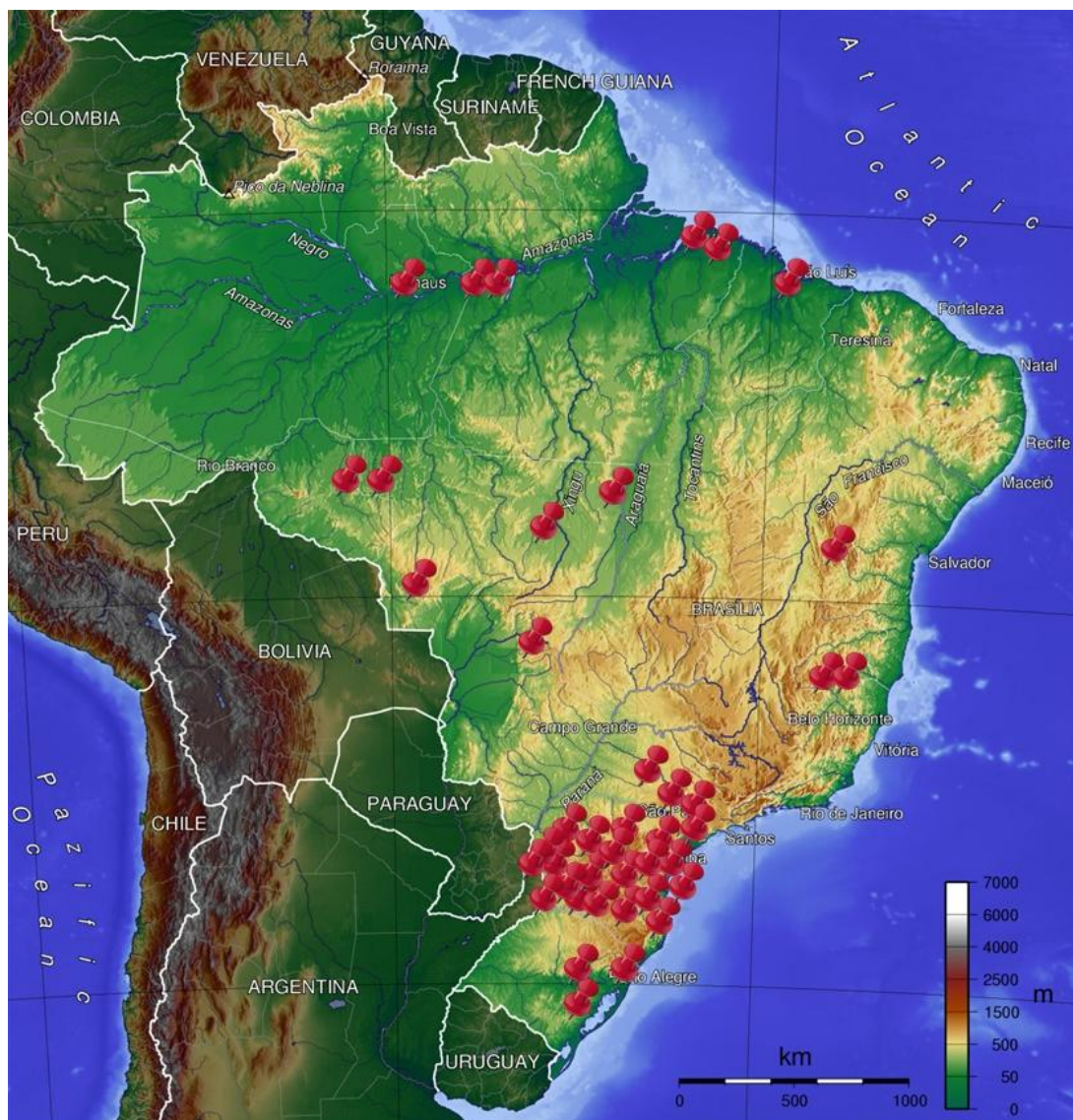

**Figure 24. Distribution of wood residues power plants in Brazil (Source: The author has located the power plants and placed them in this map of Brazil)**

A boiler is used to extract heat from hot combustion gases and transfer it to water (Figure 25). The output can be either hot water or steam (Biomass Energy Resource Center 2011). Wood chip boilers are generally used in medium and large scale installations such as blocks of flats, office buildings, airport terminals and some other purposes. Fuel quality will depend mainly at the particle size and moisture content. Large or too wet wood chips can jam the fuel system thus reducing the efficiency and reliability of the boiler. (Biomass Energy Center 2011)

Calorific value is the amount of energy released as heat during a complete combustion of a wood unit mass. The energy generated by forest biomass will depend on its calorific value and moisture content. The moisture content of wood to be used as fuel needs to be reduced as the presence of water has a negative calorific value. Additionally, low moisture content will reduce the costs of handling and transport thus adding value to the fuel. (Oliveira 2011).

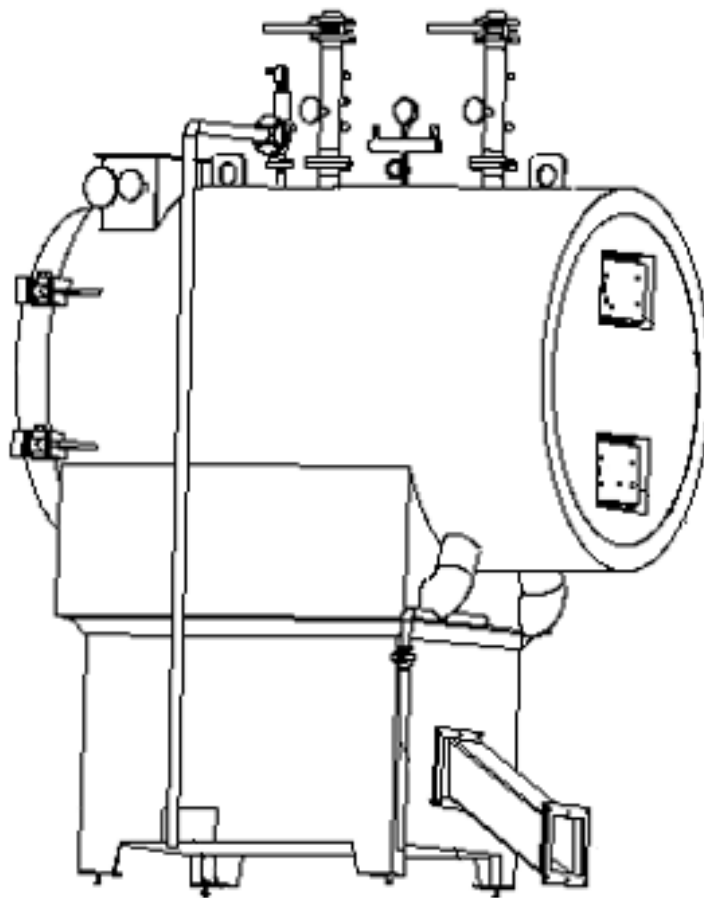

**Figure 25. Boiler designed to heat industrial premises, central and municipal heating plants, farm buildings and hotels utilizing wood chip as fuel (Source: Step Trutnov 2011)**

A full list of companies that manufacture boilers and furnaces utilizing wood chips as fuel can be found as appendix 3. These companies sell their equipment to a wide range of customers coming from diversified segments.

### **3.4 Brazilian biomass incentive programs**

The Brazilian government has created a number of incentive programs in order to increase the participation of renewable sources in the national energy matrix. The most important of these have been listed below.

**Program Luz para Todos:** The Brazilian government plans to increase the use of biomass as a source for electricity. Biomass is already being utilized for the electrification of rural areas through the program “Luz para Todos” (Light for All). The program is coordinated by the Ministério de Minas e Energia (Ministry of Mines and Energy), operated by Eletrobrás and executed by electricity concessionaires and rural electrification cooperatives. The program aims to generate local energy to isolated rural communities, generate jobs and develop technological innovations. (Programa Luz para Todos 2011)

**The National Bank for Economic and Social Development (BNDES)** finances projects that promote replacement of fossil fuels by renewable energy sources. The BNDES provides the main financial support for energy generation initiatives:

- Studies and projects
- Structures and installations
- New machinery and equipment manufactured in the country
- Imported machinery and equipment with evidence of no national production and present in the domestic market
- Specialized technical services
- Information, monitoring, controlling and supervision systems (Banco Nacional do Desenvolvimento 2011)

**PROINFA** was established in order to increase the share of electricity generated by wind, hydropower and biomass. The program requires the installation of 3.300 MW which will be incorporated into the Sistema Elétrico Integrado Nacional (National Integrated Power

System). Of this amount, 1,100 MW will be from wind, 1,100 MW from small hydroelectric power plants and another 1,100 MW from biomass projects. (PROINFA 2012)

**Plano Nacional de Agroenergia** (National Agro-Energy Plan) aims to organize and expand research, development, innovation and technology transfer to ensure sustainability and competitiveness of bioenergy. The Plano Nacional de Agroenergia works with projects to increase the use of biogas, biomass and biodiesel. (Plano Nacional de Agroenergia 2006-2011)

**PNE 2030** (The Plano Nacional de Energia 2030) intends the long-term planning of the energy sector. The Plano Nacional de Energia is composed of a series of studies that seek to provide inputs for the formulation of energy policies from integrated perspectives of the available resources including biomass. (Plano Nacional de Energia 2030 2007)

**Embrapa Agroenergia** was created with the purpose of develop and coordinate research and innovation on the field of agroenergy. This research unit works exclusively with biomass from energy forests, residues, sugarcane, oils and greases for generating energy. The Embrapa Agroenergy also aims to attend the national and international demand for Biofuels and to support Brazil to become recognized as a world reference in technological and innovative solutions in the area of agroenergy. (Embrapa Agroenergia 2011)

Governmental incentive programs have been strengthening the use of renewable sources for electricity generation in Brazil. Research and financing mechanisms, for example, promote the expansion and development of energy forests in Brazil. Finance support has been aiding the establishment of planted forests and the purchase of equipment. Despite the number of incentive programs created by the government, the private sector is mainly responsible for the highest levels of investments in the forestry sector. However, government programs are still important as they provide funds for different types of investors.

## 4 WOOD CHIPS

### 4.1 Concept of a wood chip

Wood chips are small rectangular pieces of wood produced by sawmills or through harvesting operations (Biomass Energy Resource Center 2011). They are the most common type of biomass utilized in heating systems (Maker 2004). Wood chips dimensions can vary from 20-50 mm (Biomass Energy Centre) according to buyer specifications (Oliveira 2011) At sawmills they are produced by stationary chippers with wood unsuitable for lumber. At harvesting operations they are produced by mobile wood chippers with wood that does not meet customer specification or unwanted logs. When used for energy purposes wood chips should have good quality standards. (Maker 2004) Wood chip size and moisture content are important determinants for maximizing energy efficiency. Levels of contaminants, ash content and presence of slivers and sawdust can influence on combustion equipment emissions and maintenance. Moisture content is however the most important quality factor as it affects the heating value, storage properties and transport costs. Wood chips containing excessive moisture content have a lower selling price than wood chips containing low moisture content. (Hakkila 2003). Wood chips are much more efficient fuel than logs. They can form a uniform fuel that is easier to feed into a boiler, gasifier or other conversion system. Wood chips also have larger surface area in relation to their volume ratio thus burning more efficiently. (Biomass Energy Centre 2011) One ton of wood chips has energy equivalent to 60 gallons of heating oil (Rios 2009). Wood chips quality will vary according to the material they are made and the chipper model used for chipping. They can be divided in several different groups:

- *Log chips* (from delimbed stemwood),
- *Whole tree chips* (from all the above-ground biomass of a tree)
- *Logging residue chips* (waste left by commercial timber harvest including branches, brush, tree tops, stumps, etc)
- *stump chips* (from stumps)
- *Wood residue chips* (from untreated wood residues, recycled wood and off-cuts)
- *Sawing residue chips* (from sawmill residues including sawdust, cutter shavings and wood dust) and

- *Short rotation forestry chips* (from the respective energy crops). (Al-Shemmeri 2011:257, Biomass Energy Centre 2011)

It is common for tops and branches to stay in the forest to return nutrients to the soil. After the logs are chipped by the wood chipper they are blown from the chipper into delivery trucks, which will deliver them to pulp and paper mills or to biomass energy users.

#### **4.2 Wood chipping in Brazil**

Chipping is the process of densification of biomass as to reduce its volume thus lowering transport costs and facilitating its final use. Energetically this transformation is important, as more homogenous material has a higher energetic value. (Serrano 2009). If wood residues are not chipped, they cannot be viable as an energy source because of low density, low heating value and high moisture content. These drawbacks increase transport, handling and storage costs. (Felfli et al. 2010). It is very important to consider the costs of harvesting and transportation when analyzing the system utilized at the harvest of forest biomass. Forest biomass can compete with other energy sources if these costs are well defined. (MARTI, 2006).

In Brazil the densification of biomass for energy purposes has been practiced for quite a while. Wood chips are commonly used at energy plants for generating electric power or for heating in buildings. The development of wood chip market in Brazil depends on residue availability, adequate technologies and demand from the user segments. (Felfli et al. 2010). Chipping is also an alternative for trash blanketing. Heavier and thicker residues are removed and chipped by a mobile wood chipper. Woody debris or thin wood are used as biomass fuel while leaves, twigs and barks are left in the field for soil nutrition. (Foelkel 2007)

The domestic market for wood in Brazil has been growing mainly due to reforestation of the Eucalyptus plantations. The average growth of Eucalyptus in Brazil is 41 m<sup>3</sup>/ha/year, which is three times higher than countries like Portugal and Spain. (Neutzling and Palmeira 2007). The main use of eucalyptus in Brazil is for the production of wood chips. These wood chips are used for the production of reconstituted wood-based panels such as



Medium Density Fiberboard (MDF), Medium Density Particleboard (MDP) and Oriented Strand Board (OSB), and as raw materials for pulp mills.

There are a large number of companies and individual farmers that commercialize wood chips through agricultural classified advertisings online. Buyers also publish their interest in buying wood chips through these classified advertisings (MF Rural 2011). A list of companies commercializing wood chips can be found in Appendix 4.

There is a Brazilian Association of Biomass Industries (ABIB), which is formed by a group of biomass companies interested in the expansion of biomass use for heating and energy applications. Among these companies are biomass fuel producers, appliance manufacturers and distributors, and supply chain companies. According to ABIB, its associates produce:

- Wood Chips from *Eucalyptus*: 2,300,000 tons/year
- Wood Chips from *Pinus*: 4,000,000 tons/year
- Wood Chips from *Acácia*: 600,000 tons/year

ABIB associates produce around 4,000 tons of wood chips per week, corresponding to 240,000 gallons of oil. (Oliveira 2011)

FAOSTAT (FOOD AND AGRICULTURE ORGANIZATION OF THE UNITED NATIONS) provides time-series and cross sectional data relating to food and agriculture for some 200 countries. According to FAOSTAT in 2009 Brazil produced 13,958,000 m<sup>3</sup> of wood residues and 6,986,000 of chips and particles.

MDF (Medium Density Fiberboard) is a composite material consisting of a mix of processed wood fibers from wood chips with a synthetic resin or other bonding agents and joined together under heat and pressure (Jenkins 1998). The result is an industrial panel which is smooth, dense, even surfaced and homogenous thus being free from knots, grain, and other natural defects present in lumber. In Brazil MDF is produced with Pine and Eucalyptus wood cut from sustainable forests. (ABIPA 2011). MDF is used basically for furniture and cabinetry being also used for laminate floors, skirting boards, embossed molded doors, door jambs, routed door faces, shaped parts like stair banisters, table legs and also for packaging. Medium Density Fiberboard (MDF) companies in Brazil have a

production capacity of 4.2 million m<sup>3</sup> per year (Table 5). Investments in the order of US\$ 1.2 billion are expected to increase the capacity to 5.7 million m<sup>3</sup> per year in 2012. (ABIPA 2011). MDF is mainly utilized by the furniture industry (55 %), retail (33 %), construction (8 %) and flooring (4 %).

**Table 5. MDF production, imports, exports and domestic consumption (Source: ABIPA 2012)**

MDF (m <sup>3</sup> )					
Year	Production	Imports	Exports	Domestic Consumption	Nominal Installed Capacity
2005	1,407,730	165,600	159,810	1,413,520	1,700,000
2006	1,695,359	238,000	73,300	1,860,859	1,800,000
2007	1,879,072	200,300	42,190	2,037,182	2,357,000
2008	2,073,796	215,900	26,800	2,262,896	2,547,000
2009	2,394,677	121,542	32,838	2,483,381	3,685,000
2010	3,036,337	152,660	24,445	3,164,552	4,193,000

### 4.3 Wood chips export from Brazil

According to the harmonized system code (NCM) 44012200 (non-coniferous in chips or particles) the amount of wood chips exported was of 1,049,364,511 kg in 2008 and 771,342,164 kg in 2009 (Secretaria da Agricultura, Irrigação e Reforma Agrária 2009). It is known therefore that the majority of the exports are wood chips for pulp and paper production abroad, mainly for Japan and the United States. The largest exporters of wood chips in the world in 2010 were Australia and Chile (Figure 26) and the major importers were Japan and Finland. Brazil occupied the ninth position in 2010 with a total of 1,489,965 tons of wood chips exported and had a surplus of US\$ 86.253 million due to its imports not being expressive. The Brazilian government is planning new investments for the coming years which can still improve the country's position among other wood chip exporting countries. (Neutzling and Palmeira 2007).

In Brazil the company Tanac is the leading company in export of wood chips. Tanac invested US\$ 5 million in the expansion of its industrial plant for wood chips in the city of

Rio Grande. The company also invested US\$ 15 million in the acquisition of land in the south of Brazil. Tanac has today 28,000 hectares of planted forests. In partnership with other company, Tanac also invested a sum equivalent to 22 million Euros in the expansion of the Port of Rio Grande Terminal. (*Página Rural*, 18 July 2005).

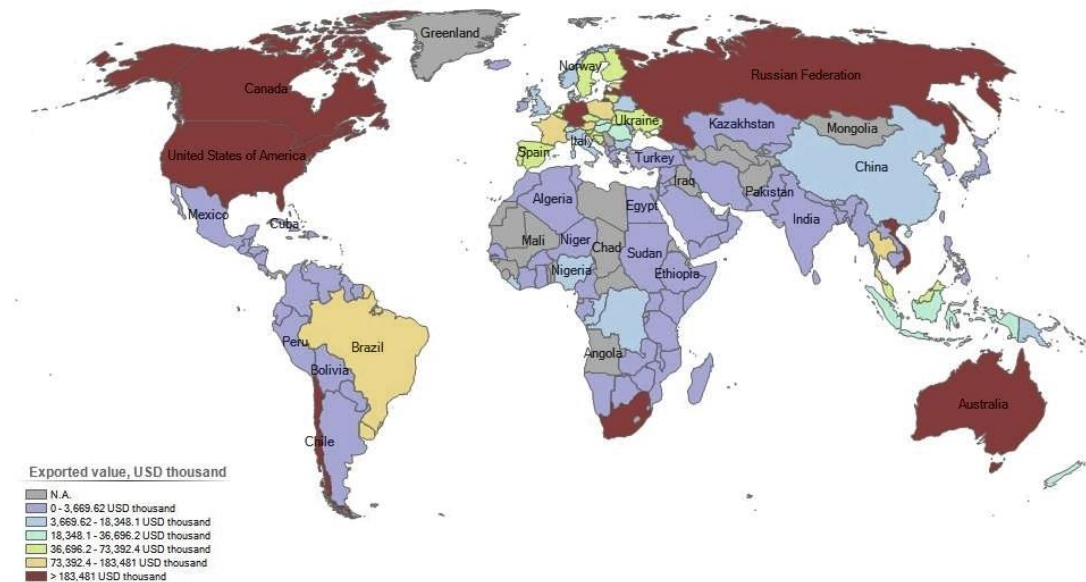

**Figure 26. Fuel wood exporters in 2010 (Source: World Trade Organization 2011)**

There are some constrains in exporting of wood chips from Brazil:

*Supply oscillations:* A while ago attractive prices and biomass surplus encouraged producers to export but nowadays there is a high demand from the pulp and paper industry in Brazil offering attractive prices and long-term contracts.

- *Local demand for biomass residues:* In the south of Brazil there is already a market for biomass residues from wood industries which reduces the number of production for exporting.
- *Currency ratio:* The fluctuation of currency exchange rate can be also an exporting barrier. The strengthening of the Brazilian currency (Real) relative to the US dollar reduced the profit of exports.
- *Logistics:* This is the main barrier for exporting wood chips. Many planted forests are located far away from maritime ports thus making the road transport costs very high. (Walter and Dolzan 2009). An adequate alternative for the Northern and Centre-Western regions of Brazil would be the use of fluvial transport through the

large number of existent rivers appropriated for this purpose. In case of Northern-Eastern and South-Eastern regions the use of a multi-modal transport in which fluvial transport connects with road transport would be a good alternative.

- *Ports for wood chip export:* Despite Brazil possessing the 16th longest national coastline of the world and a favored area for the structuring of ports, most of the existing ones are public and their service are expensive (Figure 27). Moreover, most of these ports are inefficient as they are not equipped for fast carrying biomass bulk such as wood chips which have low aggregated value. (Walter and Dolzan 2009)



**Figure 27. Main ports in Brazil (Source: Ministério dos Transportes 2011)**

Big companies such as Tanac solve this problem by building private ports placed in strategic areas. These ports are well structured and specialized, equipped with belt-carriers

for the transport of wood chips from the storage area to the port terminal. Thus, Tanac have gained high competitive prices in the external market. (Walter et al. 2006).

#### **4.4 Wood chippers**

There are different types of wood chippers and its choice will be determined by the dimensions of the biomass to be chipped, the amount of chips required to be produced, desired production rate and size and uniformity of the chips. Larger chipper models are ideal for areas with great availability of biomass. These chippers have very limited mobility due to their weight and dimensions but have the advantage of processing large amounts of forest residues. Smaller chipper models have the advantage of being mobile and agile in the forest. These chippers have better ability to adapt to uneven terrain and soils with low bearing capacity. Chippers can be fed manually or by a hydraulic crane which transfers the material to a horizontal feeding table. The feeding table moves the material into an infeed opening with hydraulic rollers that push the material into the chipper. (Leinonen 2004). Productivity will depend on different factors such as chipper model, biomass characteristics, workplace area and climate conditions. The discharge of wood chips is generated by a “pneumatic push” or a belt system. Productivity will depend on different factors such as chipper model, biomass characteristics, workplace area and climate conditions. Wood chippers can be equipped with their own engine or be attached to trucks and tractors in order to use them as a power source (Kallio & Leinonen 2005). Some wood chipper models are equipped with their own engine and crane, whereas smaller chippers can be towed by tractors or trucks with a mounted loader. Wood chippers can also be constructed on a truck chassis. Basically there are two types of chippers: disc and drum chippers. (Leinonen 2004)

##### **4.4.1 Disc chippers**

Disc chippers (Figure 28) have a rotation disc with rectangular holes where the chipper knives are attached radially and projected at an angle at the disc surface (Figure 30). On its opposite side there are arranged flanges which acts as a fan to project the chips through the output chute. Disc chippers are generally used for waste disposal since the quality of chips produced are of lower quality. Disc chippers are commonly mobiles and attached to the

tractor PTO (power take-off) and will require about 70 to 100hp. Feeding is usually manual or through hydraulic light cranes. Disc chippers are suitable only for whole tree chipping due to their small feeding opening. The chipper disc is more sensitive to impurities and therefore more suitable for homogeneous raw material such as delimbed trees. (Tolosana, Ambrosio, Laina and Ferrari 2008)

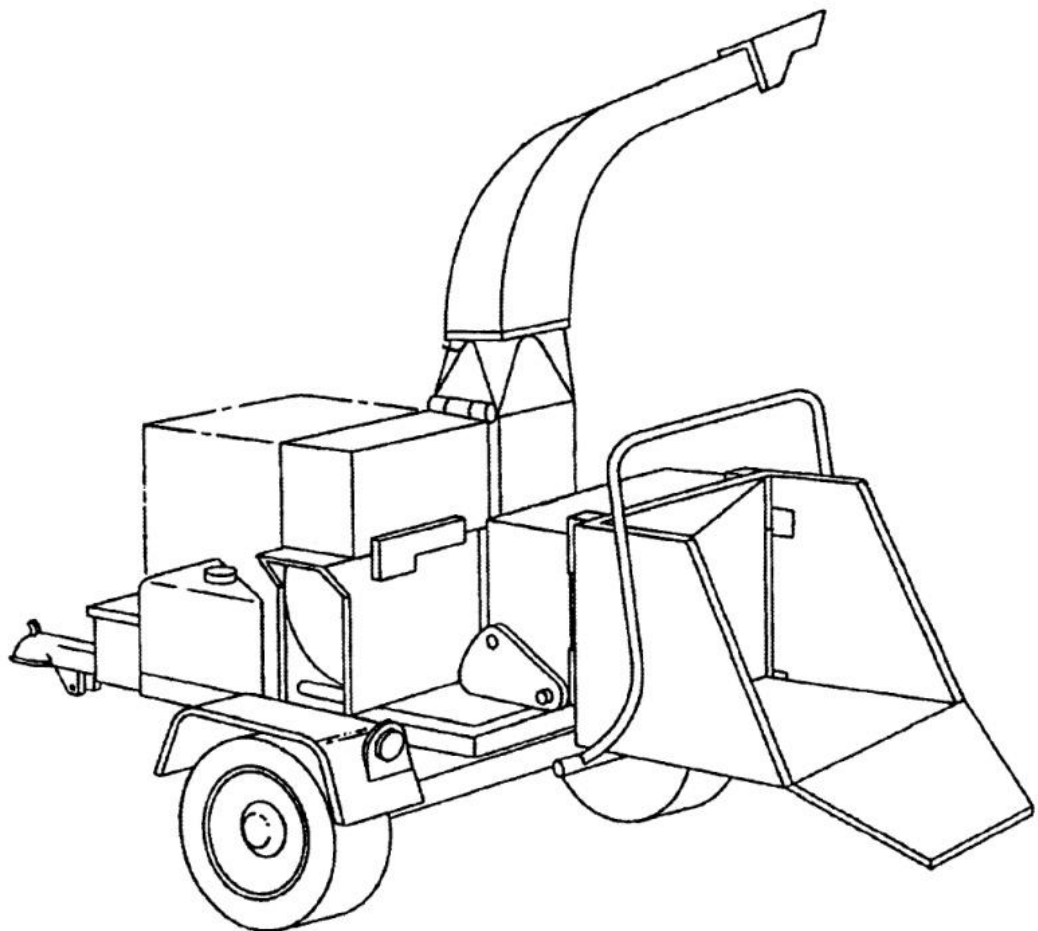

**Figure 28. Disc chipper (Source: Free Patents Online 2011)**

#### **4.4.2 Drum chippers**

Drum chippers (Figure 29) have bigger feeding opening which makes them suitable for chipping both whole trees and forest residues. In this kind of chipper there is a rotating drum with a diameter of about 450-1800 mm in which the knives are inserted in 2 to 4 longitudinal grooves in the curved surface (Figure 31). (Leinonen 2004) Drum chippers

will require more power than disc chippers but the quality of the chips are better producing chips that are more homogenous. Drum chippers can be attached to tractors with 100 hp, or frequently more than 150 hp can also be attached or integrated to forwarders and trucks. (Tolosana et al. 2008) Drum chippers are not sensitive to the heterogeneity of the raw material thus being suitable for processing forest residues (Alakangas, Sauranen and Vesisenaho 1999)

Both disc and drum chippers have its knives passing a fixed anvil and are equipped with a fan which blows the chips out of the chipper housing through a chute into the truck trailer. In some models the discharge can be also made through a belt system. (Leinonen 2004)

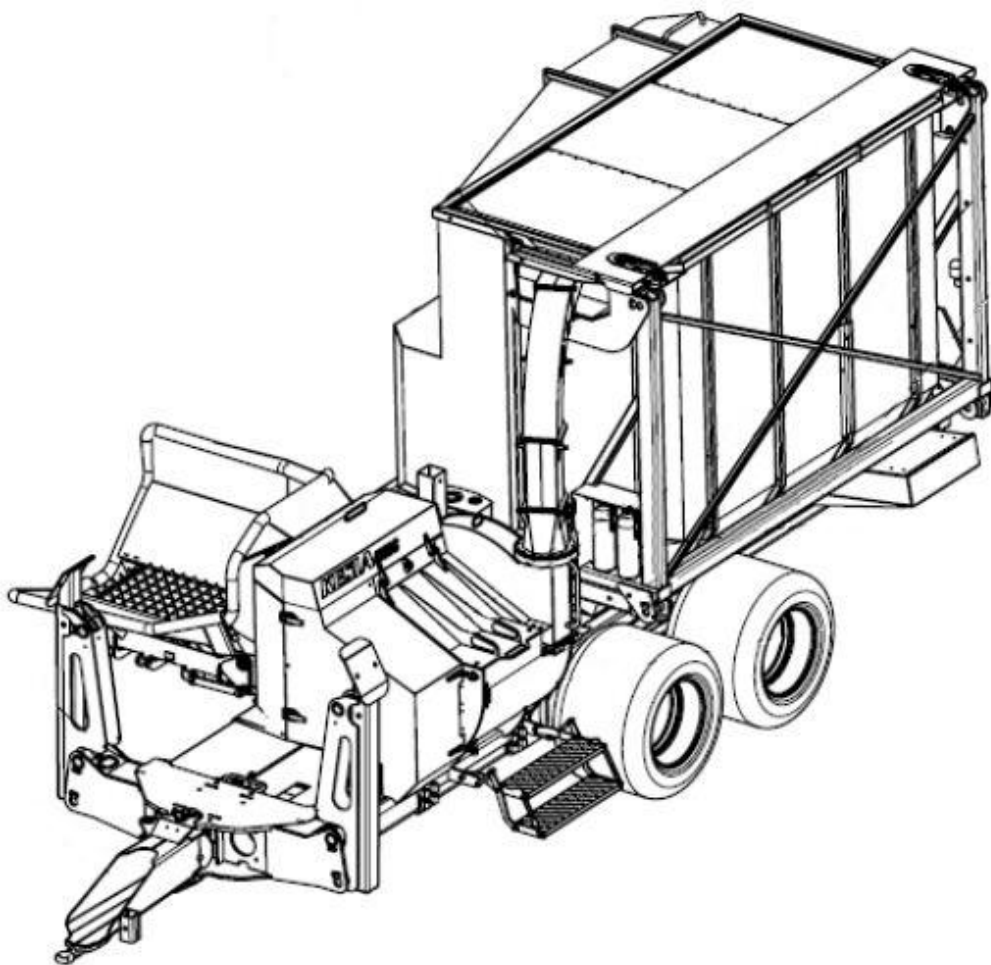

**Figure 29. Drum chipper (Source: Kesla Oyj 2006)**

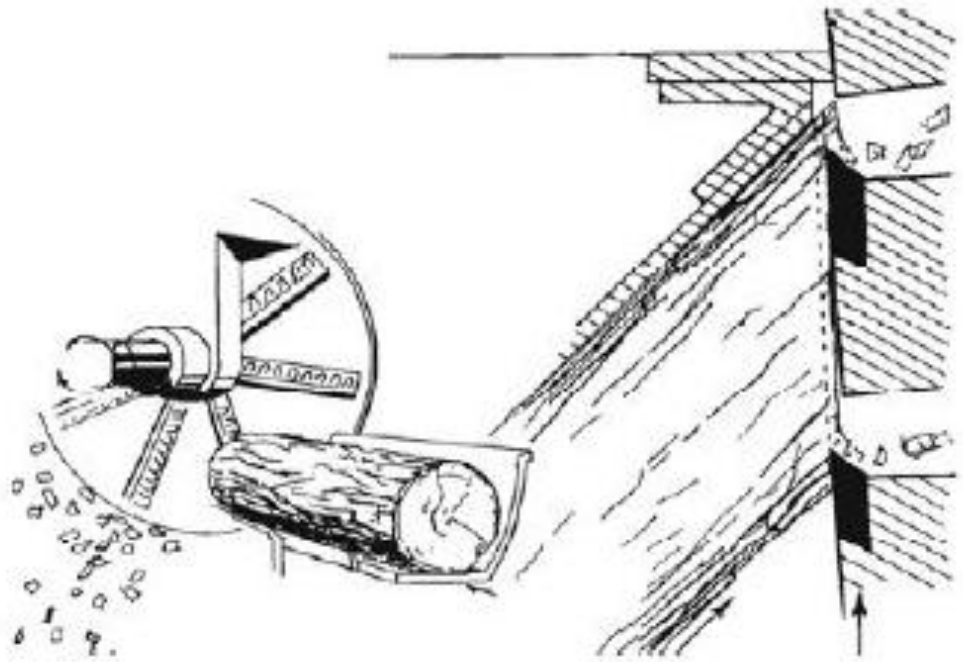

Figure 30. Schematic of a disc chipper (Source: Searcy and Hess 2010:45)

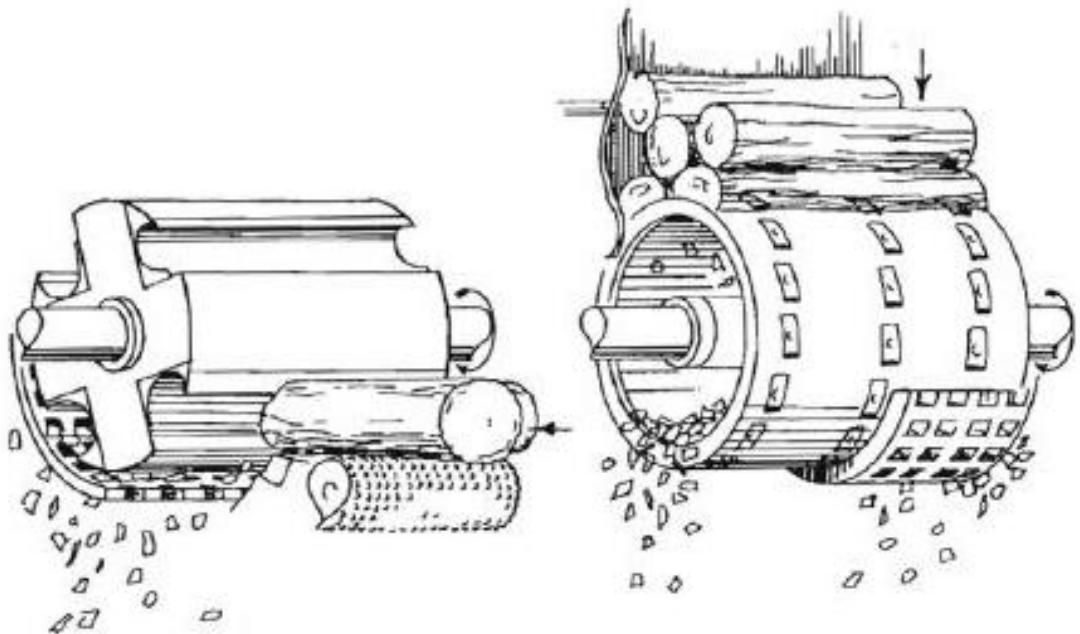

Figure 31. Schematic of a drum chipper (Source: Searcy and Hess 2010:46)



#### 4.5 Mechanized harvesting methods and wood chipping in Brazil

Harvesting activities are responsible for supplying the raw material (wood), which is required for posterior processing into wood chips, thus constituting an intermediate stage between forest resources and its transformation into wood chips. Planning, implementation, organization and control of forest activities using efficient systems can bring maximum productivity, good product quality, minimal environmental impact and lower production costs.

The harvesting methods presented below, connected to wood chippers, represent the methods being practiced in Brazil, of which CTL is the most common.

- *CTL method:* In Brazil the oldest and most common method utilized in forest plantations is *cut-to-length*. In this method the tree is cut, delimited and slashed into logs of 3 to 6 meters in the forest by a Harvester. A Forwarder makes the transport of the logs to the roadside or intermediary yards. The Forwarder can also extract the residues left by the Harvester in one or both sides of the track. A wood chipper can be added to the cut-to-length system being placed either at the roadside, in the forest, in the intermediate yard or at the factory. (Leinonen 2004)
- *Full tree method:* In the case of full tree method, the common mechanized system utilized in short rotation plantations are composed by Feller-buncher, Skidder and Wood chipper. In energy forests the use of Forwarders instead of Skidders are recommended as skidders collect sand and soil particles when dragging the trees thus contaminating the material to be chipped. In this method the use of Grinders is more common due to the addition of impurities acquired by the tree branches when they were dragged on the forest ground by a Skidder. The Grinder will be placed at the roadside or at an intermediate yard for chipping the residues. The chips will be either loaded into trucks or placed on the ground for later load. (Leinonen 2004)
- *Chipping at roadsides (Roadside method):* Forest residues are transported to the roadside to be chipped by mobile wood chippers. At the roadside the material can be stored in order to reduce its moisture content before chipping. After chipping the material is usually placed directly into trucks to be transported to the power plant. (Leinonen 2004)
- *Chipping at intermediate yard method:* Chipping can also occur at an intermediate yard where they can be stored to reduce moisture levels and be subsequently

chipped. Chippers used in this system have higher production capacity. Wood chips produced at the yard can be directly loaded into trucks or accumulated in the ground forming stockpiles. (Leinonen 2004). This method is recommended for supplying large power plants as it brings the possibility of storage building of large stocks and have a better control of the process. The chips produced can also have a better quality due to the improvement in its drying process. (Hakkila 2003)

- *Chipping at the energy plant method:* The residues are transported to the energy plant without any previous processing. Stationary chippers located at the plant will chip the residues brought from the forest. Low density of the wood residues can raise the cost per volume transported. This means that transport distances should not be long. This system can bring the benefits of eliminating the running costs of a mobile chipper in the field and facilitating the logistic process. (Leinonen 2004)
- *Thinnings method:* Thinnings are performed as intermediate cuttings removing part of the forest trees to control stand density and reduce competition between trees for light, moisture and soil nutrients. The material removed from thinnings can also be utilized as energetic biomass. Energy wood heads or chainsaws can be utilized to remove the selected trees. These trees can be placed along the forest tracks to be loaded by Forwarders which transport the material to the roadside. A wood chipper located at the roadside will chip the material and load trucks for transport. (Hakkila 2003)

Wood chip quality is affected by direction and speed of the log entering the wood chipper. Cutting knives angle, cutting speed and regular maintenance of the chipper knives can also affect the quality of the chips. Sand, soil and stones cause the wear of chipper knives. High moisture content of wood makes it easier for the chipper to cut it thus reducing energy consumption and the risk of damaging the knives. (Oliveira 2011)

## 5. LEGISLATION AND CUSTOM PROCEDURES IN EXPORTING GOODS TO BRAZIL

There are several general aspects which must be considered about entering to Brazilian markets and have been explained with details:

**Tariffs:** Brazil is a MERCOSUL (Common Market of the Southern Cone) member and thus exempts Argentina, Paraguay and Uruguay from its import duties. Other countries outside MERCOSUL need to pay the Common External Tariff (CET), which is typically between 14 % and 20 %, depending on the product being imported. Brazil keeps a list of products that are exempted from the CET as these products are not being produced in the country or if they are being produced in Brazil they cannot attend the demand. There is a list of merchandise exempted from the CET which obtains a significant import tax reduction of 2 % over the declared value.

**Commercial Invoices:** It is a requirement from Brazilian authorities that commercial invoices are included with the imported goods. These commercial invoices must have an exact description of the imported goods in Portuguese, show country of origin, date and place of shipment, markings and numerical order of packages, weight, prices along with insurance and shipping. (Manual Básico de Importação 2007)

**Import Certificates** are required for specific goods, most commonly for food and health products.

**Import Duties and Sales Taxes:** All goods imported to Brazil are subject to import duties with the exception of the ones which meet the best interests of the Brazilian economy. Product classifications will determine rates for specific imports and some of these rates can be negotiable. The two major taxes on imports charged by the Brazilian authorities are: the industrial products tax (IPI) and the tax on the distribution of goods and services (ICMS). The ICMS and IPI taxes will vary depending on the category of the product and its importance to the Brazilian economy. ICMS is similar to the European VAT, a state tax for goods and services. The ICMS value will also change according to the state where the product is being imported. Less developed states will charge lower rates. The IPI is a basic tax applied to industrial products manufactured in Brazil or imported. This tax is calculated

based on the sales price, shipping cost and import duty. The IPI will also change depending on the product classification. Brazilian importers are usually charged a minimum of 1.65 % for PIS and 7.6 % for COFINS taxes. PIS stands for “Programa de Integração Social” (Social Integration Program) and COFINS for “Contribuição para o Financiamento da Seguridade Social” (Contribution for the Financing of Social Security). (Import Regulation and Costs – Brazil 2011)

**Import / Export License:** Before Brazilian companies begin their activities in foreign trade, they need first to qualify as importers or exporters with the Federal Revenue Department. Both importers and exporters will then receive a license to have access to SISCOMEX. SISCOMEX is an automated system which allows importers or customs brokers to enter information directly into the system.

**Special customs regimes** are a group of different exceptions to the general rule applied on the taxation of imported goods to Brazil. In addition, these special customs regimes can also give the possibility of differentiated treatment at the Brazilian customs control. (Regimes Aduaneiros Especiais 2011). In the specific case of wood chippers Brazilian authorities understand that there are already a number of domestic wood chipper manufacturers but they are not managing to meet the growing demand from the market. Moreover, the country aims in increasing the production of forest biomass. In order to achieve this goal in short term, special customs regimes are needed for facilitating the imports of additional equipment.

**The “ex tarifario”** regime is a mechanism for cost reduction in the purchase of capital goods, information technology and telecommunications. It consists of a temporary reduction of the import duty of these goods to 2 % for a period of 2 years when there is no domestic production. The concession to this regime is given through a resolution from the Chamber of Foreign Commerce (Câmara de Comércio Exterior) after consulting the Review Committee of Ex-Tariff (Comitê de Análise de Ex-Tarifários) (Ministério do Desenvolvimento, Indústria e Comércio 2011)

**Declaration of Non-Similarity** gives permission to importing firms to benefit from ICMS (Tax on the Distribution of Goods and Services) tax exemption on imported machinery and equipment with no similar produced at the importing state. State industry entities are

responsible for researching the existence or not of similar machines or equipment in the state where the goods will be imported. If no similar machine or equipment is found, a “Declaration of Non-Similarity” is issued by the Secretaria do Desenvolvimento e Assuntos Internacionais (Department of Development and International Affairs). Due to the long nature of the process is recommended that importers present the necessary documentation well in advance before the arrival of the imports. (FIERGS 2011)

**FUNDAP** is a special state fiscal incentive created by the government of the State of Espírito Santo to increase export and import operations through the port of Vitória, and to give financial support to projects made in that state. This incentive provides qualified companies located in the State of Espírito Santo payment of the ICMS (VAT equivalent) only when the sale is effected. Normally companies have to pay for the ICMS as soon as the goods are nationalized. The ICMS, PIS and COFINS taxes are lower than in other Brazilian states. Furthermore, the BANDES (Development Bank of the State of Espírito Santo) finance 2/3 of the ICMS levied for a period of 20 years with a grace period of 5 years without monetary adjustment and with interest of 1 % p.a. As a consequence, the importer may incorporate this cost reduction and increase in profit margin or as a factor reducing the selling price of the product making it more competitive. (Fundo do Desenvolvimento das Atividades Portuárias 2011)

Table 6 describes estimated taxes and duties a foreign manufacturer meets when exporting to Brazil a product with the HS code 8432.80.00 (Forestry equipment utilized for delimiting, debarking, chipping of Eucalyptus logs, powered by diesel engine with power of 950HP or more, towed on wheels, used for producing wood chips designated to the manufacturing of pulp/pellets, with maximum capacity of 90T/h, with knuckle boom of two telescopic sections, feeding grapple with load capacity equal or exceeding 5,000 kg and chip discharge chute.) The final price differences are significant in comparison of the same HS code product manufactured in Finland and Brazil. Product price described in the table is illustrative as well as freight and insurance costs. The table presented has the objective to notice the taxes that would be applied at the Brazilian customs. Import taxes are charged based on the product price plus freight and insurance.

It is important to note that production costs in Brazil are not that different from Finland. The main advantage of domestic competitors lies on the avoidance of import taxes. In the case of international competitors, they would face the same import taxes applied to Kesla.

**Table 6. Related costs for forest equipment (HS Code 8432.80.00) in Brazil (2011)**

<b>Estimated Costs HS Code 8432.80.00</b>			
<b>Description</b>	<b>Tax rate</b>	<b>Product Finland</b>	<b>Product Brazil</b>
F.O.B.		100.00	100.00
Freight		1.00	
Insurance		0.55	
Customs Value		101.55	100.00
Import Tax (14%)	14.00	14.22	
IPI (0%)	0,00	0,00	
PIS (Federal Tax)	1.65	2.14	
COFINS (Federal Tax)	7.60	8.95	
ICMS (for São Paulo state)	18.00	22.83	18.00
TOTAL (not including handling fees)		149.69	118.00

## **6. OPPORTUNITIES FOR KESLA IN BRAZIL**

### **6.1 Demand and consumer market**

There is a growing demand in Brazil for alternative energy sources. Brazil has a high competitive market thus forcing companies to constantly seek ways to reduce their production costs. An option for achieving good results is through the rational use of energy. Brazilian companies are trying to minimize the power consumption utilized through the production process. The efficient use of thermal energy through the use of furnaces and boilers brings the reduction of costs and energy waste and the benefits of a sustainable energy source. Wood-fuelled heating systems have been utilized in various sectors in Brazil such as in the timber industry, in the production of red ceramic, beverage, food, retreading tires, sugar and alcohol, textile, fertilizer, chemical, metallurgy, agricultural energy cogeneration sector, hotels and block of flats. In the timber industry sector wood chips are used for thermal energy generation in order to dry paper, wood and veneer. (Simioni, Hoeflich and Siqueira 2009). This means that every company, that has a boiler or furnace where wood can be used as fuel, is a potential consumer of wood chips (Paula 2006).

### **6.2 Competitors in Brazil (wood chippers)**

There are a considerable number of wood chipper manufactures in Brazil. Some wood chippers are produced in the country using national technology, while in other cases they are either imported or manufactured through international licenses. The advance of the Brazilian technological developments has been provided by the transfer of technology from developed countries. Brazil's level of competitiveness has been improved since the opening of the economy in the 1990's with a significant liberalization of its trade. (Dias and Vergueiro 1998). The list presenting both domestic and foreign wood chipper manufacturers operating in Brazil added with a brief description of the products can be found as Appendix 5.

In Brazil Kesla faces a high number of domestic and foreign competitors. The market of wood chipper in Brazil is characterized by a large number of foreign and domestic

companies, which do not have a significant market share. The use of wood chips as fuel is increasing in the country thus generating a large number of companies interested in exploring this market. However, none of them had enough time to become a leader on the field.

### **6.3 Potential entry modes for Kesla**

It is important for any company which decides to enter a foreign market to determine the best entry mode to be used. The choice of foreign market entry mode should be based between risks and investment returns, on the extent of the company resources, and the degree of control the company wishes to possess over the foreign operations. (Kotler, Wong, Saunders and Armstrong 2005). The entry mode is important as it determines the degree of a company's control over the marketing mix program, and to an extent the degree of its commitment, in the target market (Albaum and Duerr 2008).

When a company decides to enter a foreign market it needs to make an important strategic decision concerning which entry mode it should use in a determined market. There are a variety of entry modes to be chosen: exporting, joint venturing and direct investment. Each entry mode has its own benefits and risks. The bigger the amount of commitment, control and profit potential the bigger are the risks. (Kotler et al. 2005)

Usually the entry mode to be adopted by a company will follow a determined sequence which can start with exporting in earlier stages and then gradually move to direct investment later on. This entry mode shift will be influenced by the experience and the knowledge the company gains from the host market and its local partners (Figure 32). (Zhang, Zhang and Liu, 2007)



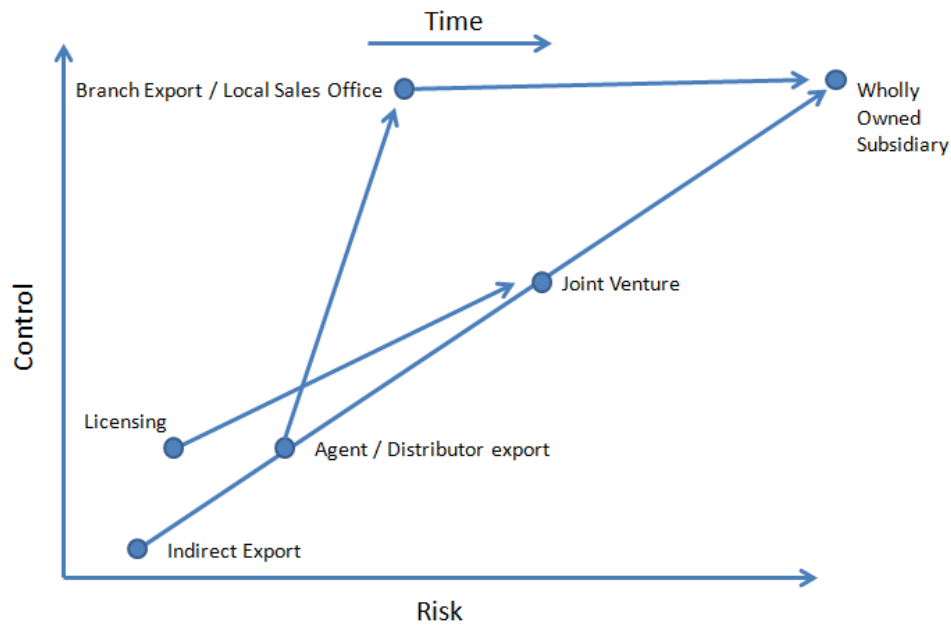

**Figure 32. Evolution of entry mode decision (Source: Andexer, 2006:45)**

### 6.3.1 Indirect exporting

The basic way to enter a foreign market is through exporting. The risks are low and the company continues producing its goods in its home country. There is less change in the company's product lines, organization, investments or mission. (Kotler et al. 2005). Kesla has been exporting its products through indirect exporting with exception of Russia, where they own a subsidiary in Saint Petersburg. This particular entry mode has been proved successful for Kesla in South America through their dealers in Chile and Uruguay.

Some advantages of indirect exporting include less investment required and less risk. The company has minimal involvement in the export process and can concentrate in the domestic market. Through indirect exporting a company can test its products in a new market and be able to forecast its potential. A local agent abroad can also provide technical knowledge to customers and necessary product support. Among the advantages for Kesla in indirect exporting is that the company can continue producing its goods in Finland thus been able to control its manufacturing quality. There is less change in the company's product lines, organization, mission and does requires less investments. (Kotler et al. 2005). Furthermore, Kesla can additionally tests its products in new markets and be able to

forecast its potential. A local dealer abroad can also provide technical knowledge to customers and necessary product support. Usually the dealer knows the market area (including culture, language and business norms) and the needs of the customers. A local dealer has also already built relationships with its customers and knows how to find new ones. A dealer can also help with financial arrangements, payment collection, personal services and exporting paperwork. (Delaney 1998)

Some disadvantages of indirect exporting are the lack of control over the foreign sales and lower profits. The company also rarely knows the end user, thus losing the opportunity to tailor its offers and respond to the customer's evolving needs. The intermediary might also work with other similar products, including directly competitive products to the same customers instead of providing exclusive representation. In other words, dealers usually have many different clients, and will concentrate their efforts on the most profitable ones. Dealers do not provide deeper market information and normally do not have enough information to contribute to product development or product choice. In case the company decides to change its long-term goals for the export program, it will be harder if the intermediary is already involved. (Delaney 1998)

Good examples from indirect exporting happening in Brazil in the wood chip business can be found with the companies Bear Cat (North America) and Mus-Max (Austria). These companies are present in Brazil through dealers, Engemac and Braflorest, respectively.

Kesla could also establish cooperation with an export trading company. For example, the company Atech Sistemas Inteligentes does already import grapples, grapple saws, tire tracks, rotators, cranes and log bunks from Europe, North America and Australia. So far Atech does not yet represent any wood chipper company and this could be an opportunity for Kesla. Atech also exports to Latin America and Kesla could take advantage of this expansion.

### **6.3.2 Direct exporting**

Some companies may eventually move into direct exporting. In direct exporting, the company exports directly to the customer without the presence of intermediaries. The company is responsible for the logistics and for collecting payment. Although the potential

return is higher than in an indirect exporting the risks are considerably larger. A company can set up a domestic export department or an overseas sales branch that takes care of distribution, sales and promotion. The sales branch gives the company greater degree of control over all aspects of the transaction in the foreign market. It gives the seller more presence and can serve as a display center and customer service. Other ways for direct exporting include sending salespeople abroad to find business, through foreign-based distributors that buy and own the goods or through foreign-based agents that sell the goods on behalf of the company (Kotler et al. 2005). Direct exporting has been practised by the Americans CBI (Continental Biomass Industries) and Vermeer. Both companies have offices in Brazil taking care of their sales.

Some advantages of direct exporting are the faster and more direct feedback from the customers about the product and its performance in the marketplace. The company becomes acquainted with its customers thus giving them assurance to make business directly. The company improves its trademarks protection, patents and copyrights. The company develops a better understanding of the marketplace. The company has greater flexibility to improve or redirect marketing strategies. A direct exporting is a good way to maximize control, profits and market presence. It is important to note that some companies can have even two intermediaries between themselves and the foreign customer thus increasing the retail price for the customer. It would be much profitable to eliminate intermediaries and sell direct to customers. Through direct exporting Kesla could have access to faster and direct feedback from customers about the product and its performance in the host market. The company could also become acquainted with its customers thus giving them assurance to make business directly. Additionally Kesla could develop a better understanding of the marketplace. The company could have greater flexibility to improve or redirect marketing strategies. (Delaney 1998). Kesla could also have a sales branch located in Brazil, as is the case with St. Petersburg, which could take care of distribution, sales and promotion. The sales branch could give flexibility for Kesla to visit potential customers, forestry fairs in Brazil and South America, have space for demo, maintenance and repairs, spare parts stock. Another advantage for Kesla is the potential a sales branch could give in expanding its reach to other countries in South America thus gathering fast and reliable information from the market situation.

On the other hand direct exporting requires the need to contract more personnel in order to cultivate a customer base. More responsibility will be required from the company from every level of the organization as there will be no intermediaries between the company and the customer. The company might not be able to respond to customers as quickly as a local dealer could. The company also has to handle all the logistics of the transaction. (Delaney 1998)

### **6.3.3 Joint venturing**

The method of joint venturing consists to enter a foreign market associating with a foreign company to produce or market a product or service. Joint venture has four types: licensing, contract manufacturing, management contracting and joint ownership. (Kotler et al. 2005). The purpose of a joint venture agreement is to establish the general principles, terms and conditions that will regulate the association of the parties, implementation of their project, the rights and obligations of each party. In Brazil the legislation does not have regulated joint ventures and does not establish any special treatment for these terms. A joint venture agreement is considered to be an exceptional agreement which is created between two or more parties. Additionally Brazilian law does not request any particular form to be adopted in a joint venture agreement. However, a joint venture agreement is subject to the general rules established in the Brazilian Civil Code. (Campbell and Netzer 2009).

#### **6.3.3.1 Licensing**

Licensing is a method of entering a foreign market, where the company offers its license to another company through an agreement. This gives a permission to use intellectual property rights to a *licensee* in the foreign market for a fee or royalty. Some disadvantages when licensing is that a company has less control over the licensee. In case the licensee achieves great success the company has given up these profits if it was instead invested in a direct investment. A licensee can also become a competitor after the end of the contract. (Kotler et al. 2005).

Licensing could be an option for Kesla to enter the Brazilian market. The Brazilian company would then produce and market the products in Brazil paying royalties back to

Kesla in Finland. Wood chipper manufacturing companies such as Jenz GmbH is operating in Brazil through licensing its intellectual property rights to a Brazilian company. Planalto Indústria e Comércio Ltda holds the rights to manufacture and market German Jenz GmbH. Through licensing its products to Planalto, Jenz benefits from manufacturing costs and import taxes. In addition, Jenz can also take advantage of preferential tariff rates for exporting its products to other Mercosur countries.

### **6.3.3.2 Contract manufacturing**

A company can also make a contract with manufacturers in the foreign market to produce its product, parts or service on their behalf. This method brings the benefits for a company to start faster, with less risk, with lower costs and with the advantage to utilize local expertise in selling the product. There is also the opportunity for the companies to form a partnership or for the company to buy the local manufacturer. The down points in contracting manufacturing include a low control level over the manufacturing process and the loss of potential profits on manufacturing. (Kotler et al. 2005).

A good alternative for Kesla in Brazil would be to start cooperation with a well established company, domestic or multinational, which has a well distributed network in Brazil. This company could manufacture Kesla's products or its parts to be assembled in Brazil. If the domestic partner company has the expertise and technology to manufacture and assembly the necessary percentage required to nationalize the product, then Kesla could reduce the Brazilian import tariffs. Additionally the Brazilian partner could provide service, maintenance and spare parts stock to attend the customer. Many Brazilian companies have dealers in other countries in South America, and Kesla could also use Brazil in accessing other markets in the continent.

Best companies to join cooperation with Kesla include tractor, truck or implement manufacturers. An agreement with such company could benefit both parts as both companies would complement each other in the forestry market. The Brazilian partner would also benefit with the addition of a new market for its products as Kesla products work as attachments for tractors and trucks. A list of potential partners for Kesla can be found in Appendix 5.

The partner company would also benefit from adding a forestry line to its product range complementing with Kesla attachments. The company would not need to develop new equipment as this has already been done by Kesla. The company could either import or manufacture or assembly Kesla attachments in Brazil. The advantage of assembly and manufacturing in Brazil would reduce import duties thus beating foreign competitor's price which import their products to Brazil. Both companies would provide an integrated solution to customers. For instance, an excavator with an attached harvester head will work as a forest harvester. If the customer disconnects the harvester head, it is possible to utilize the excavator for other purposes (e.g. digging). This flexibility of use would fit better with the needs of Brazilian customers compared with a specific purpose built machine.

Cooperation with companies which are already manufacturing forestry equipment or attachments, and are lacking of a specific product to its product range, would be an option. For example, companies TMO, Randon, J.de Souza, Hidromáquinas Fort need wood chippers to their attachments range.

#### **6.3.3.3 Joint ownership**

In this method foreign investors will join with domestic investors to create a local business where the ownership and control are shared by both parties. It is possible to a foreign company to buy shares of a local firm or for both parties to form a new business venture. Joint ownership is attractive for companies which do not possess financial, physical or managerial resources to undertake the venture alone. (Kotler et al. 2005). A joint ownership could be an alternative for Kesla for the future, in case the company considers the Brazilian market positive and makes a decision to stay. However, this would be a huge and risky step for Kesla requiring large investments.

#### **6.3.3.4 Management contracting**

This joint venture consists of a foreign company supplying the capital to a domestic company which will provide know-how on management services. This method offers a low risk for a company entering a foreign market and produces income from the beginning. (Kotler et al. 2005) For Kesla this joint venture would not be suitable since Kesla does not

have the means to acquire its own factory or assembly line installations to be managed by a domestic management company

#### **6.3.4 Direct investment**

Direct investment represents the ultimate association in a foreign market. A foreign company makes investments in foreign based assembly or manufacturing facilities. This kind of investment should be avoided by companies that have no previous experiences entering foreign markets. Foreign production facilities will offer advantages in cases that the foreign market appears to be large enough or growing rapidly.

Some advantages provided by direct investment include the access to lower costs of raw materials or cheap labor, incentives from the local government and freight savings. The company enhances its image in the host country as it will provide jobs for its citizens. The company can better adapt its products to the local market by developing a deeper relationship with government, customers, local suppliers and distributors. The direct investment provides full control of the firm over the investment thus allowing the development of manufacturing and marketing policies. (Kotler et al. 2005). One of the main disadvantages of direct investment is that the company becomes very vulnerable to risks such as restricted, devalued or rising currencies, worsening markets or governmental takeovers.

#### **6.4 Conclusions**

Brazil is a strong emerging market with high potential to become an energy powerhouse. Brazilian government has put barriers on the import of heavy machinery in order to support the national industry and persuade foreign companies to build factories inside the country. These barriers influence the decision in which entry mode to be adapted in Brazil. High import tariffs imposed by Brazilian authorities over manufactured goods are the main obstacle for Kesla to enter the market by its usual entry mode, indirect exporting. The protectionism of the Brazilian domestic industry forces foreign companies (such as Kesla) to search for new ways to enter the market.

Due to the high taxes applied to manufactured imported goods to Brazil is imperative for Kesla to search ways to avoid it through making some kind of cooperation in Brazil or utilizing a special customs regime in its favor. High import taxes are a determinant factor for companies deciding to enter a foreign market. These taxes affect the final product price to customers and will be decisive for competing against domestic and foreign competitors. Some foreign competitors are already well established in Brazil possessing either assembly lines or licensees.

In the specific case of the wood chipper equipment manufactured by Kesla, it was found that the utilization of special customs regime would diminish its import duties through an indirect export.

Working through dealers has lower risks, and it is a common practice for Kesla when operating abroad. Apart from import taxes, the important factor for Kesla through indirect export is to find a strong local partner, preferably with a good network. It would be also essential for the dealer to have good spare parts storage and maintenance service expertise in order to be able to cover the Brazilian territory and be competent in the service. Maintenance and repairs on site are important in order to beat competitors which are already offering this service.

It was concluded that the existence of biomass boiler manufacturers, wood chip exports and wood chipper manufacturers and importers present in Brazil are a sign, that there is a market for Kesla wood chippers. Additionally, the creation of sustainable energy programs developed by the Brazilian government to support the use of wood chips as a clean alternative for electricity generation, are a good indication of ongoing demand. Special customs regimes which facilitate the imports of wood chippers to Brazil are also an indication of the wish of Brazilian government to promote the use of wood chips as an energy source.

It was also found that Brazil has a growing demand for wood chippers since there is a special custom regime defined for the exemption of general taxation of wood chippers to attend the national demand. Local harvesting practices are also favourable for the use of mobile wood chippers on the roadsides. A large number of national and international



mobile wood chipper manufacturers are already present in the country offering wide range of models.

Brazil offers many opportunities for forestry and bioenergy companies due to its vast natural resources and government incentives for the research and development of renewable energy sources. Brazil foresees a growing global demand for energy in the future and aims to decrease the use of fossil fuels in its energy matrix. Considering its natural resources, Brazil is engaged in promoting the use of renewable sources as means of becoming a strong supplier in the near future.

Despite the increasing interest of the Brazilian government in promoting renewable sources as forest biomass, it was difficult to find any previous studies concerning the wood chips market in Brazil. Through this study it was possible to discover that the wood chip market is active in Brazil, since there are various sectors of the economy involved, such as wood chipper manufacturers, biomass boilers and furnaces manufacturers, wood chip sale through classified advertisings, energy forests, government incentives and different sectors utilizing wood chips as fuel. Figure 33 presents following SWOT analysis referent to Kesla and the present market situation in Brazil.

<p><b>Strengths</b></p> <ul style="list-style-type: none"> <li>• Market leader in forestry attachments</li> <li>• Kesla is already present in South America</li> <li>• Manufactures sophisticated equipment with high quality standards</li> <li>• Very wide range of forestry attachments</li> <li>• Knowledge of different operational environments</li> <li>• Finnish products reputation in Brazil</li> </ul>	<p><b>Opportunities</b></p> <ul style="list-style-type: none"> <li>• Brazil is an emerging economy with constant economic growth</li> <li>• Brazilian currency is getting stronger</li> <li>• Big market for forestry machinery</li> <li>• The wood chip market will increase following the concern of the Brazilian government in promoting renewable energy sources</li> <li>• Special customs regime “Ex Tarifário” for wood chippers</li> </ul>
<p><b>Weaknesses</b></p> <ul style="list-style-type: none"> <li>• Kesla brand is not know in Brazil</li> <li>• Kesla has no partner in Brazil for servicing the wood chippers</li> <li>• Kesla has no partner in Brazil for sales, spare parts stock or customer support</li> </ul>	<p><b>Threats</b></p> <ul style="list-style-type: none"> <li>• Domestic competitors price</li> <li>• Import taxes</li> <li>• FINAME – Finances the acquisition of new machinery and equipment manufactured in Brazil</li> <li>• Find a skillful partner to manufacture such high tech equipment</li> <li>• International competitors already established or represented in Brazil</li> </ul>

**Figure 33. Kesla SWOT analysis**

Further research is needed to access more closely the wood chip scenario in Brazil. A field research study involving different sectors in the wood chip market network could improve the understanding of the present and future scenario. It would also be interesting to find out the economic viability of the wood chipping process including transport distances, price

comparison to other fuels, wood chipper running costs, maintenance and repair and balance of the energy consumed and the energy produced by the wood chipper. Environmental issues, such as the impact caused by the extraction of biomass residues and the amount of material that could return nutrients to soil, should also be considered. These issues are important to take into account in order to predict the future of the wood chip market in relation to other fuels in Brazil.

## REFERENCES

- Abbud, O.A., and Tancredi, M. 2010. Transformações recentes da matriz brasileira de geração de energia elétrica – Causas e impactos principais. Brasília: Centro de Estudos da Consultoria do Senado.
- Abreu, Y.V., Oliveira, M.A.G., Guerra, S.M.G. (eds) 2010. Energia sociedade e meio ambiente. Palmas: Universidade de Málaga.
- Agência Nacional de Energia Elétrica. 2005. Atlas de Energia Elétrica do Brasil. 2nd edition. Brasília: ANEEL.
- Agência Nacional de Energia Elétrica. 2008. Atlas de energia elétrica do Brasil. 3rd edition. Brasília: ANEEL.
- Alakangas, E., Sauranen, T., and Vesisenaho, T. 1999. Production techniques of logging residue chips in Finland. Jyväskylä: VTT.
- Albaum, G., and Duerr, E. 2008. International Marketing and Export Management. Harlow: Prentice Hall.
- Al-Shemmeri, T. 2011. Energy Audits: A Workbook for Energy Management in Buildings. Oxford: Blackwell Publishing Ltd.
- Andexer, T. 2006. Analysis and Evaluation of Market Entry Modes Into the Asia-Pacific Region. Norderstedt: Grin Verlag.
- Associação Brasileira das Indústrias de Biomassa e Energia Renovável. 2010. Brazil Biomass and Renewable Energy. Available in www-form <URL: [www.internationalrenewablesenergy.com](http://www.internationalrenewablesenergy.com)> 12<sup>th</sup> April, 2011.
- Associação Brasileira da Indústria de Painéis de Madeira. 2011. *Painéis de Fibras de Média Densidade*. Available in www-form <URL: <http://www.abipa.org.br/produtosMDF.php>> 25<sup>th</sup> October, 2011.
- Associação Brasileira de Produtores de Florestas Plantadas. 2010. ABRAF statistical yearbook. Brasília: STCP Engenharia de Projetos Ltda.
- Banco Central do Brasil. 2011. *International Reserves and Liquidity in Foreign Currencies*. Available in www-form <URL: <http://www.bcb.gov.br/sddsi/templ1i.shtm>> 11<sup>th</sup> June, 2011.
- Banco Nacional do Desenvolvimento. 2011. *Financiamento de Máquinas e Equipamentos*. Available in www-form <URL: [http://www.bndes.gov.br/SiteBNDES/bndes/bndes\\_pt/Institucional/Apoio\\_Financeiro/Produtos/FINAME\\_Maquinas\\_e\\_Equipamentos/](http://www.bndes.gov.br/SiteBNDES/bndes/bndes_pt/Institucional/Apoio_Financeiro/Produtos/FINAME_Maquinas_e_Equipamentos/)> 7<sup>th</sup> November, 2011.
- Bauer, S.R. 2001. *Resíduos da exploração florestal de Eucalyptus grandis hill ex maiden para geração de energia elétrica*. Botucatu: Universidade Estadual Paulista Julio de Mesquita Filho.

Biomass Energy Centre. 2011. *Wood Chips*. Available in www-form <URL: [http://www.biomassenergycentre.org.uk/portal/page?\\_pageid=75,18515&\\_dad=portal&\\_schema=PORTAL](http://www.biomassenergycentre.org.uk/portal/page?_pageid=75,18515&_dad=portal&_schema=PORTAL)> 25<sup>th</sup> October, 2011.

Biomass Energy Centre. 2011. *What is biomass?* Available in www-form <URL: [http://www.biomassenergycentre.org.uk/portal/page?\\_pageid=76,15049&\\_dad=portal&\\_schema=PORTAL](http://www.biomassenergycentre.org.uk/portal/page?_pageid=76,15049&_dad=portal&_schema=PORTAL)> 7<sup>th</sup> September, 2011.

Biomass Energy Resource Center. 2011. *Glossary of Biomass Heating Terms*. Available in www-form <URL:<http://www.biomasscenter.org/resources/glossary.html>> 25<sup>th</sup> October, 2011.

Borenstain, S.S., Forestry Director. Veracel Celulose S/A, 10th June, 2008.

Boundy, B., Diegel, S.W., Wright, L., and Davis, S.C. 2011. *Biomass Energy Data Book: Edition 4*. Tennessee: US Department of Energy.

Brainard, L., and Martinez-Diaz, L. (eds.) 2009. *Brazil as an Economic Superpower? : Understanding Brazil's Changing Role in the Global Economy*. Washington: Brookings Institution Press.

Bridgwater, T. 2006. *Biomass for energy*, *Journal of the Science of Food and Agriculture* 86, 1755-1768.

Broadhead, J. 2008. *Forests and energy: key issues*. Rome: FAO.

Buainain, A.M., and Batalha, M.O. 2007. *Cadeia produtiva de madeira*. Brasília: Ministério da Agricultura, Pecuária e Abastecimento.

Campbell, D., and Netze, A. 2009. *International joint ventures*. Alphen aan den Rijn: Kluwer Law International.

Cascione, S. 2011. Mantega: Sound policies driving Brazil CDS below US, *Reuters*, Available in www-form <URL:<http://www.reuters.com/article/2011/06/15/brazil-derivatives-usa-idUSN1529692720110615>> 15<sup>th</sup> June 2011.

Casper, J.K. 2010. *Fossil Fuels and Pollution: The Future of Air Quality*. Brainerd: Bang Printing.

Celulose Online. 2004. *Biomassa gera 14% da energia no planeta*. Available in www-form <URL: <http://www.celuloseonline.com.br/pagina/pagina.asp?iditem=4829>> 11<sup>th</sup> June, 2011.

Centre for Economics and Business Research. 2011. *Brazil has overtaken the UK's GDP*. London: Centre for Economics and Business Research

Centro das Indústrias do Estado de São Paulo. 2007. *Manual Básico de Importação*. São Paulo: CIESP.

- Coelho, S.T. 2005. *Biofuels – Advantages and Trade Barriers*. São Paulo: United Nations Conference on Trade and Development.
- Cushion, E., Whiteman, A., and Dieterle, G. 2010. *Bioenergy development: issues and impacts for poverty and natural resource management*. Washington: World Bank Publications.
- Delaney, D. 1998. *Start and Run a Profitable Exporting Business*. North Vancouver: Self-Counsel Press Inc.
- Deloitte Global Services Limited. 2010. *Brazil's Energy Matrix and Prospects for Energy Integration with South America*. London: Deloitte.
- Dias, M.M., and Vergueiro, W. 1998. *Information and technology transfer in Brazil: evolution and perspectives*, *New Library World* 99, 112-117.
- Dubé, Y., and Schmithüsen, F. (eds.) 2003. *Cross-sectoral policy impacts between forestry and other sectors*. Rome: Food and Agriculture Organization of the United Nations.
- Embrapa Agroenergia. 2011. *Finalidades*. Available in www-form <URL: [http://www.embrapa.br/a\\_embrapa/unidades-de-pesquisa-e-de-servicos/unidades-de-temas-basicos/cnpae/embrapa-agroenergia/](http://www.embrapa.br/a_embrapa/unidades-de-pesquisa-e-de-servicos/unidades-de-temas-basicos/cnpae/embrapa-agroenergia/)> 12<sup>th</sup> April, 2011.
- Embrapa Recursos Genéticos e Biotecnologia. 2011. *A Embrapa Recursos Genéticos e Biotecnologia*. Available in www-form <URL: [http://www.cenargen.embrapa.br/\\_institucional/quemsomos.html](http://www.cenargen.embrapa.br/_institucional/quemsomos.html)> 13<sup>th</sup> December, 2011.
- Empresa de Pesquisa Energética. 2010. *Balanco Energético Nacional 2010*. Rio de Janeiro: EPE.
- Energy Information Administration. 2007. *International Energy Outlook 2007*. Washington: Energy Information Administration.
- Fagundes, H.A. 2003. *Produção de madeira serrada e geração de resíduos do processamento de madeira de florestas plantadas no Rio Grande do Sul*. Porto Alegre: Universidade Federal do Rio Grande do Sul.
- Federação das Indústrias do Estado da Bahia. 2011. *Comércio Exterior: Bahia e Brasil*. Sinopse: Federação das Indústrias do Estado da Bahia.
- Federação das Indústrias do Rio Grande do Sul. 2011. *Declaração de Não-Similaridade*. Available in www-form <URL: [http://www.fiergs.org.br/canais\\_fiergs.asp?idArea=50&idSubMenu=78](http://www.fiergs.org.br/canais_fiergs.asp?idArea=50&idSubMenu=78)> 20<sup>th</sup> June, 2011.
- Felfli, F.F., Mesa, J.M., Rocha, J.D., Filippetto, D., Luengo, C.A., and Pippo, W.A. 2010. *Biomass briquetting and its perspectives in Brazil*, *Biomass and Bioenergy* 35, 236-242.
- Fibria. 2011. *Institucional – Quem somos*. Available in www-form <URL: <http://www.fibria.com.br/web/pt/institucional/quem.htm>> 11<sup>th</sup> September, 2011.

- Foelkel, C. 2007. As fibras dos eucaliptos e as qualidades requeridas na celulose kraft para a fabricação de papel. Porto Alegre: Eucalyptus Online Book & Newsletter.
- Food and Agriculture Organization of the United Nations. 1990. Energy conservation in the mechanical forest industries. Rome: Unipub.
- Food and Agriculture Organization of the United Nations. 2003. Cross-sectoral policy impacts between forestry and other sectors. Rome: FAO
- Food and Agriculture Organization of the United Nations. 2010. Global Forest Resources, Assessment 2010. Rome: FAO
- Food and Agriculture Organization of the United Nations. 2011. *FAOSTAT*. Available in www-form <URL:<http://faostat.fao.org/default.aspx>> 7<sup>th</sup> May, 2011.
- Foreign Affairs and International Trade Canada. 2011. Import Regulations and Costs – Brazil. Available in www-form <URL:<http://www.tradecommissioner.gc.ca/eng/document.jsp?did=99249&cid=723&oid=136>> 23<sup>rd</sup> May, 2011.
- Foreign Affairs and International Trade Canada. 2010. *Overview of Brazil*. Foreign Affairs and International Trade Canada.
- Fortum. 2011. Combined heat and power production in Finland. Available in www-form <URL:<http://www.fortum.com/en/energy-production/combined-heat-and-power/finland/pages/default.aspx>> 5<sup>th</sup> October, 2011.
- Gerasimov, Y., and Seliverstov, A. 2010. Industrial Round-Wood Losses Associated with Harvesting Systems in Russia, *Croatian Journal of Forest Engineering*, 111-126.
- Global Business Policy Council. 2010. Investing in a Rebound, The 2010 A.T. Kearney FDI Confidence Index. Vienna: Global Business Policy Council.
- Goldemberg, J., La Rovere, E.L., Coelho, S.T., Simões, A.F., Guardabassi, P., Miranda, F.M. 2005. Renewable Energy Technologies to improve energy access in Brazil. São Paulo: Centro Nacional de Referência em Biomassa.
- Gomes, S.I., Paraíso, P.R., and Andrade, C.M.G. 2006. Análise Preliminar da Viabilidade de Cultivos Florestais para Produção de Energia Elétrica. Maringá: Universidade Estadual de Maringá.
- Guardabassi, P.M. 2006. *Sustentabilidade da biomassa como fonte de energia perspectivas para países em desenvolvimento*. São Paulo: Universidade de São Paulo.
- Hakkila, P. 2003. *Developing technology for large-scale production of forest chips*. Helsinki: TEKES.
- Hartsough, B., and Yomogida, D. 1996. *Compilation of State-of-the-Art Mechanization Technologies for Short-Rotation Woody Crop Production*. California: University of California.

Hartmann, H., Böhm, T., Jensen, P.D., Temmerman, M., Rabier, F., and Golser, M. 2006. *Methods for size classification of wood chips*, Biomass and Bioenergy 30, 944-953.

Ministério do Meio Ambiente. 2011. *Informações Florestais*. Available in [www-form <URL:http://homologw.mma.gov.br/index.php?ido=conteudo.monta&idEstrutura=5&idMenu=1194>](http://homologw.mma.gov.br/index.php?ido=conteudo.monta&idEstrutura=5&idMenu=1194) 30<sup>th</sup> November, 2011.

Instituto Brasileiro do Meio Ambiente e dos Recursos Naturais Renováveis. 1993. *Portaria IBAMA N° 44-N de 6 de abril de 1993*. Available in [www-form <URL: http://www.ibama.gov.br/flora/portarias/044\\_93.pdf>](http://www.ibama.gov.br/flora/portarias/044_93.pdf) 12<sup>th</sup> April, 2011.

Instituto Brasileiro do Meio Ambiente 2011. *Manejo Florestal: Conceitos*. Available in [www-form <URL:http://www.ibama.gov.br/areas-tematicas/conceitos>](http://www.ibama.gov.br/areas-tematicas/conceitos) 26<sup>th</sup> April, 2011.

International Energy Agency. 2004. *Renewable energy: market & policy trends in IEA countries*. Paris: Organization for Economic Co-operation and Development.

International Energy Agency. 2005. *Socio-Economic Drivers in Implementing Bioenergy Projects*. Washington: IEA.

International Energy Agency. 2010. *World Energy Outlook 2010*. Paris: Organization for Economic Co-operation and Development.

International Energy Agency. 2011. *What is Biomass?* Available in [www-form <URL: http://www.aboutbioenergy.info/definition.html>](http://www.aboutbioenergy.info/definition.html) 13<sup>th</sup> September, 2011.

International Trade Centre. 2011. *Trade Competitiveness Map*. Available in [www-form <URL: http://www.trademap.org/countrymap/Country\\_SelProduct\\_Map.aspx>](http://www.trademap.org/countrymap/Country_SelProduct_Map.aspx) 20<sup>th</sup> September, 2011.

Jacovine, L.A., Machado, C.C., Souza, A.P., Leite, H.G. 2001. *Avaliação da perda de madeira em cinco subsistemas de colheita florestal*, Revista Árvore 25, 463-470.

Jenkins, M.B. 1998. *The business of sustainable forestry: case studies*. Chicago: The Macarthur Foundation.

Junginger, M., Dame, J., Zarrilli, S., Mohamed, F.A., Marchal, D., and Faaij, A. 2011. *Opportunities and barriers for international bioenergy trade*, Energy Policy 39, 2028-2042.

Juslin, H., and Hansen, E. 2003. *Strategic Marketing in the Global Forest Industries*. Corvallis: Authors Academic Press.

Kallio, M., and Leinonen, A. 2005. *Production technology of forest chips in Finland*. Jyväskylä: VTT.

Kellog, L.D., Bettinger, P., and Studier, D. 1993. *Terminology of Ground-Based Mechanized Logging in the Pacific Northwest*. Oregon: Oregon State University.

Kesla Oyj. 2006. *Manual Kesla 4560C*. Joensuu: Kesla Oyj



- Kieran, G. 2010. *The global power of Brazilian agribusiness*. London: The Economist Intelligence Unit.
- Kotler, P., Wong, V., Saunders, J., and Armstrong, G. 2005. *Principles of Marketing*. 4<sup>th</sup> edition. Harlow: Prentice Hall.
- Lattimore, B., Smith, C.T., Titus, B.D., Stupak, I., and Egnell, G. 2009. *Environmental factors in woodfuel production: Opportunities, risks, and criteria and indicators for sustainable practices*. Biomass and Bioenergy, Volume 33, 1321-1342.
- Laudicina, P., and Peterson, E. 2012. *Cautious Investors Feed a Tentative Recovery, The 2012 A.T. Kearney FDI Confidence Index*. Vienna: Global Business Policy Council.
- Leahy, J. 2011. Brazil enjoys success amid global insanity, *Financial Times*, Available in www-form <URL: <http://www.ft.com/cms/s/0/0978312e-bd25-11e0-9d5d-00144feabdc0.html#axzz1fOVrtguZ>> 2<sup>nd</sup> August, 2011.
- Leinonen, A., 2004. *Harvesting technology of forest residues for fuel in the USA and Finland*. Espoo: Julkaisija-Utgivare.
- Lichtfouse, E., Hamelin, M. Navarrete, M., Debaeke, P., Souchère, V., and Alberola, C. (eds.) 2009. *Sustainable Agriculture, Volume 2*. New York: Springer
- Loo, S.V., and Koppejan, J. (eds.) 2008. *The handbook of biomass combustion and co-firing*. London: Earthscan.
- Lopes, D.C., and Neto, A.J. 2011. *Potential Crops for Biodiesel Production in Brazil: A Review*, World Journal of Agricultural Sciences 7, 206-217.
- Lund, H.F. (ed) 2001. *The McGraw-Hill recycling handbook*. 2<sup>nd</sup> edition. New York: McGraw-Hill Professional.
- Macedo, I.C. 2001. *Geração de energia elétrica a partir de biomassa no Brasil: situação atual, oportunidades e desenvolvimento*. Brasília: Centro de Gestão e Estudos Estratégicos.
- Maker, T.M. 2004. *Wood-Chip Heating Systems A Guide For Institutional and Commercial Biomass Installations*. Montpelier: Biomass Energy Resource Center.
- Martí, B.V. 1999. *Aprovechamiento de los residuos forestales para uso energético*. Valencia: Universidad Politècnica de València.
- MF Rural. 2011. Available in www-form <URL: <http://www.mfrural.com.br/busca.aspx?palavras=cavaco>> 19<sup>th</sup> April, 2011.
- Miller, G.T., and Spoolman, S. 2009. *Living in the Environment: Principles, Connections, and Solutions*. Belmont: Brooks Cole.
- Miller, G.T., and Spoolman, S. 2009. *Sustaining the Earth: an integrated approach*. Belmont: Brooks Cole.

Ministério da Agricultura, Pecuária e Abastecimento. *Plano Nacional de Agroenergia 2006-2011*. 2nd Edition. Brasília: Embrapa Informação Tecnológica.

Ministério do Desenvolvimento, Indústria e Comércio Exterior. 2011. *Exame de Similaridade*. Available in www-form <URL:

<http://www.desenvolvimento.gov.br/sitio/interna/interna.php?area=5&menu=2687>> 14th September, 2011.

Ministério do Desenvolvimento, Indústria e Comércio. 2011. *O que é o Ex-tarifário*. Available in www-form <URL:

<http://www.mdic.gov.br/sitio/interna/interna.php?area=2&menu=1174>> 1st September, 2011.

Ministério do Meio Ambiente. 2009. *Brazilian forests at a glance*. Brasília: Serviço Florestal Brasileiro.

Ministério do Meio Ambiente. 2011. *Informações Florestais*. Available in www-form <URL:

<http://homolog-w.mma.gov.br/index.php?ido=conteudo.monta&idEstrutura=5&idMenu=1194>> 5th December, 2011.

Ministério de Minas e Energia. 2007. *Plano Nacional de Energia 2030*. Brasília : MME.

Ministério de Minas e Energia. 2004. *Programa de Incentivo às Fontes Alternativas de Energia Elétrica*. Available in www-form <URL:

[http://www.mme.gov.br/programas/proinfra/menu/programa/tecnologias\\_contempladas.html](http://www.mme.gov.br/programas/proinfra/menu/programa/tecnologias_contempladas.html)> 1st December, 2011

Ministério de Minas e Energia. 2005. *Diretrizes de política de agroenergia 2006 – 2011*. Brasília: MME.

Ministério de Minas e Energia. 2010. *Resenha Energética Brasileira*. Brasília: MME.

Ministério de Minas e Energia. 2011. *Programa Luz para Todos*. Available in www-form <URL: <http://luzparatodos.mme.gov.br/>> 12<sup>th</sup> June, 2011.

Ministério dos Transportes. 2011. *Mapa dos principais portos*. Available in www-form <URL:<http://www2.transportes.gov.br/bit/05-mar/mapas-mar.html>> 1<sup>st</sup> May, 2011.

Moreira, J.R., 2002. *Biomass as a source of energy in Brazil*. São Paulo: Centro Nacional de Referência em Biomassa.

Neutzling, F.C. and Palmeira, M. 2007. *A Competitividade das Exportações Brasileiras de Cavaco de Madeira*. Pelotas: Faculdade Atlântico Sul de Pelotas.

Nicholas, I. (ed.) 2008. *Short Rotation Crops for Bioenergy Systems*. Rotorua: IEA Bioenergy.

Oliveira, C.M. 2011. *Energia Renovável e Biomassa*. 1st edition. São Paulo: Editora Cultura Jurídica.

- O'Neill, J. (ed.). 2007. *BRIC's and Beyond*. New York: Goldman Sachs Global Economics.
- O'Neill, J., and Stupnytska, A. 2009. *The Long-Term Outlook for the BRICs and N-11 Post Crisis*. New York: Goldman Sachs Global Economics.
- Página Rural. 2005. *RS terá R\$ 74 milhões de investimentos na Metade Sul*. Available in www-form <URL: <http://www.paginarural.com.br/noticia/20582/rs-tera-r-74-milhoes-de-investimentos-na-metade-sul>> 2<sup>nd</sup> August, 2011.
- Paula, J.C. 2006. *Aproveitamento de Resíduos de Madeira para Confecção de Briquetes*. Seropédica: Universidade Federal Rural do Rio de Janeiro.
- Pirages, D., and Cousins, K. (eds.) 2008. *From Resource Scarcity to Ecological Security, Exploring New Limits to Growth*. Cambridge: The MIT Press.
- Portal do Governo do Estado do Espírito Santo. 2011. *Fundo do Desenvolvimento das Atividades Portuárias*. Available in www-form <URL: <http://www.es.gov.br/site/empresas/fundap.aspx>> 12<sup>th</sup> December, 2011.
- Portal Brasil. 2010. *Development hand in hand with biodiversity conservation*. Available in www-form <URL: <http://www.brasil.gov.br/para/press/reference-texts/development-hand-in-hand-with-biodiversity-conservation>> 23<sup>th</sup> May, 2011.
- Portal do Governo do Estado do Espírito Santo. 2011. *Fundo do Desenvolvimento das Atividades Portuárias*. Available in www-form <URL: <http://www.es.gov.br/site/empresas/fundap.aspx>> 12<sup>th</sup> December, 2011.
- Portal Madeira Total. 2007. *Planalto produzirá picador com tecnologia alemã*. Available in www-form <URL: <http://madeiratotal.com.br/noticia.php?id=84&volta=noticias.php?cat=4>> 8<sup>th</sup> July, 2011.
- Porto, L. 2007. *Energias Renováveis*. São Paulo: Ministério de Minas e Energia.
- Receita Federal. 2011. *Regimes Aduaneiros Especiais*. Available in www-form <URL: <http://www.receita.fazenda.gov.br/legislacao/legisassunto/paginasdefault/regaduespdefault.htm>> 13<sup>th</sup> December, 2011.
- Reis, C.A.F., and Filho, E.P. 2011. *Estado da arte de plantios com espécies florestais de interesse para o Mato Grosso*. Colombo: Embrapa Florestas.
- Renewable Energy Policy Network for the 21st Century. 2010. *Renewables 2010, Global Status Report*. Paris: REN21.
- Rios, M. 2009. *Biomass at Williams College*. Williamstown: Williams College.
- Santos, P.P. 2008. *Central de Biomassa de Portalegre*. Portalegre: Enerwood Portalegre.
- Scandiffio, M.I. 2004. *A Liderança do Brasil em Fontes Energéticas Renováveis: Uma visão de longo prazo*. Campinas: Universidade Estadual de Campinas.

- Schubert, R., Schellnhuber, H.J., Buchmann, N., Epiney, A., Griesshammer, R., Kulesa, M., Messner, D., Rahmstorf, S., and Schmid, J. 2010. *Future Bioenergy and Sustainable Land Use*. London: Earthscan Publications Ltd.
- Schwab, K. (ed.) 2010. *The Global Competitiveness Report 2010–2011*. Geneva: World Economic Forum.
- Searcy, E.M., and Hess, J.R. 2010. *Uniform-Format Feedstock Supply System: A Commodity-Scale Design to Produce an Infrastructure-Compatible Biocrude from Lignocellulosic Biomass*. Idaho: Idaho National Laboratory.
- Secretaria da Agricultura, Irrigação e Reforma Agrária. 2009. *Exportações Brasileiras*. Salvador: Promobahia
- Serrano, D.M.C. 2009. *Avaliação do Potencial de Produção e Exportação de Pellets Combustível no Pólo Florestal da Região Sul do Brasil*. Campinas: Universidade Estadual de Campinas.
- Silva, C.R., Garrafa, M.T., Navarenho, P.L., Gado, R., and Yoshima, S. 2005. *A biomassa como alternativa energética para o Brasil*. São Paulo: Revista Brasileira de Ciências Ambientais 2, 25-36.
- Simioni, F.J., Hoeflich, V.A., Siqueira, E.S., and Binotto, E. 2009. *Análise das Transações na Cadeia Produtiva de Energia de Biomassa de Origem Florestal*. Lavras: Organizações Rurais & Agroindustriais.
- Simões, D. 2008. *Avaliação econômica de dois sistemas de colheita florestal mecanizada de eucalipto*. Botucatu: Universidade Estadual Paulista Júlio de Mesquita Filho.
- Soares, T.S., Carneiro, A.C.O., Goncalves, E.O., and Lelles, J.G. *Uso da biomassa florestal na geração de energia*. Revista Científica Eletrônica de Engenharia Florestal, ano IV, número 08.
- Sociedade Brasileira de Silvicultura. 2006. *Fatos e Números do Brasil Florestal 2006*. São Paulo: SBS
- Sociedade Brasileira de Silvicultura. 2008. *Fatos e Números do Brasil Florestal 2008*. São Paulo: SBS
- Solomon, S., Qin, D., Manning, M., Chen, Z., Marquis, M., Averyt, K.B., Tignor, M., and Miller, H.L. (eds.) 2007. *Climate Change 2007: The Physical Science Basis. Contribution of Working Group I to the Fourth Assessment Report of the Intergovernmental Panel on Climate Change*. Cambridge: Cambridge University Press.
- Souza, P.A., Barros, J.V.C., and Filho, G.F.S. 2011. *Biomassa*. Fortaleza: Universidade Federal do Ceará.
- Standard and Poor's Financial Services LLC. 2011. *Brazil Sovereign Rating Raised To 'BBB', Based On Growing Ability To Withstand Global Economic Deterioration*. New York: Standard and Poor's.

- Step Trutnov a.s. 2011. *Boilers for burning wood chips and grains*. Available in [www-form <URL:http://www.steptrutnov.cz/en/about-company.html>](http://www.steptrutnov.cz/en/about-company.html) 2<sup>nd</sup> November, 2011.
- Stokes, B.J., Ashmore, C., Rawlins, C.L., and Sirois, D.L. 2008. *Glossário de Termos em Inglês Utilizados em Colheita e Engenharia Florestal*. Auburn: United States Department of Agriculture.
- Sustainable Energy Authority of Ireland. 2011. *Biomass Sources*. Available in [www-form <URL: http://www.seai.ie/Renewables/Bioenergy/intro\\_and\\_biomass\\_sources/>](http://www.seai.ie/Renewables/Bioenergy/intro_and_biomass_sources/) 21<sup>st</sup> December, 2011.
- Sustainable Forestry Working Group. 1998. *The Business of Sustainable Forestry - Case Studies: Analyses and Case Studies*. Chicago: The Macarthur Foundation.
- The Diagnostic Mission Established Pursuant to Decision 2(XXIX). 2002. *Achieving the ITTO objective 2000 and sustainable forest management in Brazil*. Yokohama: International Tropical Timber Organization.
- Tolosana, E., Ambrosio, Y., Laina, R., and Ferrari, R.M. 2008. *Guía de la Maquinaria para el Aprovechamiento y Elaboración de Biomasa Forestal*. Madrid: Universidad Politécnica de Madrid.
- Tomaselli, I. 2007. *Forests and energy in developing countries*. Rome: FAO.
- Utriainen, T. 2007. *Finnish Practice and Experience in Bioenergy Production*. Tallin: Pöyry.
- United Nations. 2008. *Bosques y energía, Questiones Clave*. Roma: United Nations Publications.
- United Nations. 2009. *Foreign Direct Investment in Latin America and the Caribbean*. Santiago: United Nations Publication.
- United Nations. 2010. *Forest Products Annual Market Review 2009-2010*. Geneva: United Nations Publications.
- United Nations Climate Change Conference. 2010. *Meta para 2020: Brasil avanza en reducir emisiones contaminantes*. Available in [www-form <URL: http://www.cc2010.mx/es/sala-de-prensa/recursos-paraprensa/news\\_2010102835836.htm>](http://www.cc2010.mx/es/sala-de-prensa/recursos-paraprensa/news_2010102835836.htm) 27<sup>th</sup> October, 2010.
- United Nations Environment Programme. 2011. *The Bioenergy, Food and Water Nexus: Developing Country Perspectives*. Rome: United Nations.
- United Nations Framework Convention on Climate Change. 1998. *Kyoto Protocol*. Kyoto: United Nations.
- U. S. Environmental Protection Agency. 2007. *Biomass Combined Heat and Power Catalog of Technologies*. Washington: U. S. Environmental Protection Agency.

- Veracel Celulose S/A. 2011. Florestal. Available in www-form <URL: <http://www.veracel.com.br/default.aspx?tabid=72>> 20th September, 2011.
- Veracel Celulose S/A. 2010. Veracel Relatório de Sustentabilidade 2010. Eunápolis: Veracel Celulose S/A.
- Veracel Celulose S/A. 2011. *Resumo do Plano de Manejo Integrado*. Eunápolis: Veracel Celulose S/A.
- Walden Publishing Ltd. 2005. *Brazil Business Intelligence Report*. Cambridge: World of Information.
- Walter, A., Dolzan, P., and Piacente, E. 2006. *Biomass Energy and Bio-energy Trade: Historic Developments in Brazil and Current Opportunities*. Campinas: Universidade Estadual de Campinas.
- Walter, A., and Dolzan P. 2009. *Country Report Brazil*. Campinas: International Energy Agency.
- World Business Council for Sustainable Development. 2005. *Pathways to 2050: Energy & Climate Change*. Conches-Geneva: WBCSD.
- World Energy Council. 2010. *Survey of Energy Resources 2010*. London: World Energy Council.
- World Wide Fund for Nature. 2007. *Agenda Elétrica Sustentável 2020*. 2<sup>nd</sup> edition. Available in www-form <URL: <http://www.wwf.org.br/informacoes/biblioteca/index.cfm?uNewsID=9060>> 12<sup>th</sup> December, 2011.
- Yapp, R. 2011. BG Group to invest \$10bn in Brazilian deepwater oil fields, *The Telegraph*, Available in www-form <URL: <http://www.telegraph.co.uk/finance/newsbysector/energy/oilandgas/8279371/BG-Group-to-invest-10bn-in-Brazilian-deepwater-oil-fields.html>> 24<sup>th</sup> January, 2011.
- Zhang, Y., Zhang, Z., and Zhixue, L. 2007. *Choice of entry modes in sequential FDI in an emerging economy*, Management Decision 45, 749-772.

## **Report of a visit to forest plantation at Veracel in 2008 with Kesla**

Veracel is the result of a joint-venture between two companies in the pulp and paper industry, Brazilian Fibria (Merger of Aracruz and Votorantim Creates Fibria) and Swedish-Finnish Stora Enso Treasury Amsterdam BV. In 2008 the company was still a partnership between the Brazilian Aracruz Celulose S/A and Swedish-Finnish Stora Enso Treasury Amsterdam BV. Veracel's pulp mill is considered one of the world's most advanced in the sector, operating since 2005 to produce highly qualified pulp fiber. The plant/mill has the capacity to produce 1.1 million tons of bleached cellulose pulp per year. Veracel has an area of 91.429 hectares of Eucalyptus plantations and 114.625 hectares of environmentally protected area. Its operations include the production and planting of Eucalyptus seedlings, pulp production and the transport of the final product. (Fibria 2011)

The production is divided between Fibria and Stora Enso. Fibria adds its production part to its sales volume abroad while Stora Enso incorporates its part in the production of paper in its various international units. (Veracel Relatório de Sustentabilidade 2006 e 2010). The pulp mill facilities are located in the center of the *Eucalyptus* plantations and at an average distance of 45 km for wood to be transported from the forest to the factory. Veracel is also situated at 60 kilometers from the Belmonte Marítimo Terminal which transfers the pulp to the Portocel harbor specialized in pulp export.

The purpose to visit Veracel was to gather information on technology and practices utilized in forest plantations in Brazil. Large forest plantations such as Veracel are commonly owned by large organizations, usually pulp mills, whereas small plantations are held by farmers.

Planting at Veracel is made entirely with *Eucalyptus* clones obtained from breeding *Eucalyptus grandis* and *Eucalyptus urophylla* species. Veracel produces *Eucalyptus* seedlings from its own seedling nursery which has capacity to produce 24 million seedlings per year.

## APPENDIX 1 (2/8)

The soil is prepared by tractors equipped with subsoiler (Figure A1) which digs a layer of 90 cm deep/depth into the soil (Figure A2). Phosphate fertilizer is also applied during the subsoiling. The planting of seedlings (Figure A3) is mechanized. A billet planter (Figure A4) is attached to a tractor which positions the seedling in the soil fertilized it with NPK (Nitrogen, Phosphorus and Potassium) and a polymer gel (Figure A5) is also applied to retain moisture in the roots thus replacing irrigation. Planting interval is 3 x 3m and the average annual productivity is of 63 m<sup>3</sup>/ha/year, wood density of 506 kg/m<sup>3</sup> and rotation period of 7 years. Harvesting is carried out by harvesters (Figure A6) which debark and cut the wood into 6m logs. The wood that does not meet this specification is utilized to generate energy at the mill. Bark, leaves and small branches are left on the field for nutrition and soil protection (Figure A7). Forwarders (Figure A8) are used to collect the logs and pile them at the roadside for transport. The logs are loaded into trucks that transport them to the mill for processing.

A harvester operator at Veracel will cut an average of 75 trees per hour or 490 per day and a Forwarder operator piles up about 260 m<sup>3</sup> of wood per day. Veracel is concerned with road conditions and there is constant road maintenance to reduce travel times in the process of mill supply.

In Brazil Eucalyptus trees are generally harvested by seven years while Pine is harvested with 15 years if going to be used for fiber and between 25 to 30 years if used for timber. The Eucalyptus are debarked if the factories cannot use the bark as fuel or if the transport distance are long and the weight loaded needs to be decreased.

### Description of the harvesting at Veracel

Veracel had a total of 34 harvesters: 18 Volvo EC210B and 16 Komatsu PC228 equipped with Harvester Heads Valmet 370E and Waratah HTH 260. Forwarders used were Valmet 890.3 and John Deere 1710D, 8-wheeled. The harvesting operations at Veracel are carried out by three teams divided in three working shifts. Each team was equipped with 11 harvesters and seven forwarders and a mobile office equipped with service center, internet connection and dining rooms (Figure A9).



The machine operators receive six months training and additional time with simulators in the forest organized by Veracel. Each harvester produces an average of 10 000 m<sup>3</sup>/month. Base machines have an average life of 25000h and harvesters 12500h. The base machines equipped with harvester heads run in 2 shifts of 8 hours with an average of 11 full working hours a day with an output of 30m<sup>3</sup>/h.

### **Logging sites**

Thinning is not done at Veracel, only clear-cutting. The average diameter of the Eucalyptus trees when ready to be harvested are of 20-22 cm (diameter breast height) and length of 30m. Each machine operator has its production output monitored by an electronic control system which prints the information from each shift.

- Output example from 06/06/08:
- 11 machines - total output: 3657 m<sup>3</sup>
- Operating hours total: 137
- Output per hour average: 28.62 m<sup>3</sup> / h
- Technical occupancy: 84 %

### **Harvester and forwarder system practiced at Veracel**

#### **Figure A2. Eucalyptus seedling planted at 90 cm depth soil.**

Veracel applies the CTL (*cut-to-length*) harvesting system (Figure A10) in its Eucalyptus plantations determining harvested logs to have between 3 to 6 m lengths. From that 80 % must be between 5.8 to 6.0 m. Debark rate performed was of 98 % with an established minimum of 97 %. Trees are cut, delimited and debarked by a harvester head attached to an excavator. The logs are consecutively loaded by forwarders that carried the logs to be piled at the roadside. The transport to the mill is carried out by trucks. The biomass residues are left in the field for additional soil protection and nutrition after the harvest.



**Figure A1. Subsoiler attached to a crawler dozer digging 90 cm depth layer**



**Figure A2. Eucalyptus seedling planted at 90 cm depth soil.**



**Figure A3. Eucalyptus seedling (clone)**



**Picture A4. Billet planter (tractor attached)**



**Figure A5. Polymer gel**



**Figure A6. Harvester at Veracel**



**Figure A7. Wood residues left on the field at Veracel.**



**Figure A8. Forwarder at Veracel**



**Figure A9. Mobile “on-site” office**

	<p>Tracked harvester fells, delimits and crosscuts the trees into lengths of 3 to 6 m.</p>
	<p>The forwarder loads and transports the logs to the nearest logging road.</p>
	<p>A loader loads timber trucks which will transport them to the Veracel mill.</p>

**Figure A10. Cut-to-length at Veracel.**

**Locations of wood residues power plants in Brazil**

Location of wood residues power plants in Brazil

Pimenta Bueno/RO	Nova Campina/SP	Encruzilhada do Sul/RS
Salete/SC	General Carneiro/PR	Porto Alegre do Norte/MT
Três Barras/SC	Piraí do Sul/PR	Juruena/MT
Rio Negrinho/SC	Inácio Martins/PR	Sinop/MT
Faxinal dos Guedes/SC	Agudos do Sul/PR	Comodoro/MT
Chapecó/SC	Dois Vizinhos/PR	Alto Araguaia/MT
Canoinhas/SC	Guarapuava/PR	Itacoatiara/MT (2)
Vargem Bonita/SC	Carambeí/PR	Manaus/AM
Rio Negrinho/SC	União da Vitória/PR	Belém/PA (2)
Lages/SC	Guarapuava/PR	Grão Mogol/MG (2)
Limeira/SP	Toledo/PR	Chapadinha/MA
Ribeirão Preto/SP	Imbituva/PR	São Desidério/BA
São Paulo/SP	Piratini/RS	

**(Source: Atlas de Energia Elétrica do Brasil 2008)**

## **List of companies manufacturing wood chip boilers and furnaces in Brazil**

### **Aalborg Industries Brasil**

Aalborg Industries is a Danish manufacturer of boilers for various purposes and is present in 13 countries. Aalborg Industries Brasil manufactures industrial boilers which burns/utilize oil, gas, firewood, briquettes, wood chips, bagace and pellets. Products manufactured in Brazil: Fire tube boilers, thermal fluid heaters, water tube boilers, heat recovery boilers for combined use of turbines and gas engines, accessories for boilers and supervisory system with remote access for monitoring boilers.

**Location:** Petrópolis/RJ, Água Fria/SP and Macaé/RJ

**Website:** <http://www.aalborg-industries.com.br/index.php>

### **MML Ind. e Com. de Caldeiras Ltda**

MML manufactures steam and hot water boilers which burns liquid and solid fuels. The company also provides boiler accessories, technical assistance and spare parts.

Manufactures hot water generator, tankless water heater, external furnace, biomass automatic tankless, biomass, biomass external box steam furnace, biomass automatic steam furnace, hot water tanks, residential and sauna heaters.

**Location:** Lambari/MG

**Website:** <http://www.mmlcaldeiras.com.br/>

### **Sermatec Zanini**

Manufacturer of heavy equipment including water-tube boilers, circulating and bubbling, fluidized bed boilers, fire-tube boilers, recovery boilers (HRSG), waste boilers, deaerators, bagasse conveyors, instrumentation assembly and industrial process automation, low- and medium-voltage electrical assemblies and electric panels. In 2009 Sermatec delivered 22 new plants for bioelectricity generation, accounting for the generation of 150 MWh in average for the Brazilian energy matrix. Sermatec boilers are designed to burn sugarcane bagasse, chopped wood, forestry waste and other biomass. Sermatec has also installed more than 500 fire-tube boilers since its foundation in 1976.

**Location:** Sertãozinho/SP

**Website:** <http://www.sermatec.com.br/por/empresa.php?pag=ZW1wcmVzYQ==>

### **Icaterm Caldeiras, Aquecedores e Queimadores Ltda**

Manufacturer and importer of equipment for the generation of hot water, steam and heat. Manufacturer of boilers, thermal fluid heaters, industrial heaters and hot water tanks. Icaterm imports steam generators, industrial heaters, furnaces and heat exchangers from the North American Clayton Industries.

**Location:** São Paulo/SP



**Website:** <http://www.icaterm.com.br/>

### **Engecass Equipamentos Industriais Ltda**

Manufacturer of thermal energy generator systems on its Steam Division. Manufactures water tube boilers, aquaflame tube boilers, horizontal fire tube boilers, oil and gaz boilers, vertical boilers, wood dryers, horizontal and vertical silos.

**Location:** Rio do Sul/SC

**Website:** <http://www.engecass.com.br/index.htm>

### **H.Bremer & Filhos**

Manufactures fire tube boilers, water tube boilers, heaters and components. Customer range includes food industry, refrigeration industry, paper industry, chemical industry, and textile industry.

**Location:** Rio do Sul/SC

**Website:** <http://www.bremer.com.br/novo/index.php>

### **Probat Leogap**

Manufactures machinery and equipment for the coffee industry and bioenergy industry. Manufactures furnaces for drying biomass such as wood chips, sugarcane bagasse, grass and others), wood chippers, water heaters, kiln dryers for sawn wood, silos and wood chips conveyors.

**Location:** Curitiba/PR

**Website:** <http://www.leogap.com.br/index.php?pg=principal>

### **AG Therm Caldeiras Equipamentos Ltd**

Manufactures water and fire tube boilers for burning solid, liquid and gaseous fuels for industrial processes and thermoelectric power. Manufactures vertical and steam boilers, furnaces and peripheral equipment for boilers. Among its customers include laundry services, pharmaceutical companies, food industry, nonwoven fabric, paper and cellulose, agro-industry, textile, beverage, rubber parts and car tires, machinery and equipment, footwear, hospital, university, armed forces, transport, disposable packaging, chemical and plastic industry.

**Location:** São José dos Campos/SP

**Website:** <http://www.agtherm.com.br/index.htm>

### **SECAMAQ - Indústria de Máquinas Ltda**

**Manufacturer of boilers, thermal fluid heaters and sawnwood kilns.**

**Location:** Salete/SC

**Website:**

<http://www.secamaq.com.br/default.php?pg=principal&radioGroup=%5Bobject+Object%5D>

**Biochamm Caldeiras e Equipamentos Industriais Ltda**

Manufactures boilers, burners, thermal fluid heaters, horizontal silos, air heaters, silo discharges, deaerators, multicyclone separators and mobile extractors.

Its products are used in the most variable applications in the sugar and alcohol, paper and cellulose sectors, in the wood, timber and MDF industry, in the cogeneration of energy, in the agricultural, food, textile, fertilizers and chemical industries, in the siderurgy and metallurgic, brewery sectors and others. The company commercializes its products mainly in the states of Paraná, Minas Gerais, São Paulo, Rio Grande do Sul, Santa Catarina, Goiás and Pará. The company also makes international sales to Chile, Costa Rica, Argentina, Paraguay, Uruguay, Italy, France, Austria, Portugal and Spain

**Location:** Agrolândia/SC

**Website:** <http://www.biochamm.com.br/site/pt/index.php>

***BENECKE IRMÃOS & CIA LTDA***

Manufactures fire tube boilers, water tube boilers, thermal power stations, boiler sleeve filters, feeding and storage systems for boilers. The company also manufactures log debarkers and sawnwood kilns.

**Location:** Timbó/SC

**Website:** <http://www.benecke.com.br/>

**WECO S/A - Indústria de Equipamento Termo-Mecânico**

Manufacturer of heating systems, water tube boilers, steam boilers, heat exchangers, autoclaves, furnaces, burners, tanks and thermal insulation. Its equipment burns firewood, rice husk, cane bagasse and wood chips.

**Location:** Porto Alegre/RS

**Website:** <http://www.weco.ind.br/Empresa/Historico.aspx>

**Hidrotécnica Soluções em Aquecimento**

Hidrotécnica Soluções em Aquecimento focuses on sustainable solutions for heating such as solar energy, biomass and waste. The company also manufactures traditional gas, electrical and diesel heaters. The range of customers includes hotels, factories, leisure clubs, spas and hospitals.

Hidrotécnica Soluções em Aquecimento manufactures boilers and heaters burning logs, briquettes, pellets and wood chips.

**Location:** Diadema/SP

**Website:** <http://www.hidrotecnica.com.br/index.asp>

**Rohden Termo Engenharia**

Manufacturer of biomass burners, water heaters, multi-cyclone filters, boilers blowers, air preheaters and combustion diagnostics.

**Location:** Rio do Sul/SC

**Website:** <http://www.caldeiras.ind.br/>

**ICAVI – Indústria de Caldeiras Vale do Itajaí S/A**

Manufacturer of water tube boilers, BFG (Blast Furnace Gas) Boilers, fire tube boilers, thermal fluid heaters, biomass burners, dry heat generator, biomass handling and storage systems and gas filtration systems.

**Location:** Pouso Redondo/SC

**Website:** <http://www.icavi.ind.br/>

**Ecomatek-Ecosol**

Ecomatek-Ecosol manufactures machines and equipment for heating water. It includes heaters, hot water generators, isothermal tanks, tankless heaters and solar heaters.

**Location:** Londrina/PR

**Website:** <http://www.aquecedoresecosol.com.br/>

**Areva Koblitz Ltda.**

Brazilian renewable energy developer which designs and constructs turnkey power plants fuelled with biomass. The company also offers expertise in carbon credits registration and certification

**Location:** Recife/PE

**Website:** [www.arevakoblitz.com/](http://www.arevakoblitz.com/)

## List of companies commercializing wood chips in Brazil

### **Briquetes Curitiba**

Suppliers of briquettes, eucalyptus and pine wood chips, pellets for fuel use in boilers, dryers and furnaces.

**Location:** Curitiba/PR

**Website:** <http://briquetescuritiba.wordpress.com/>

### **Madecal**

Produces sawn wood, biocomposites, briquettes, logs, wood chips and wood shavings.

**Location:** São Carlos/SP

**Website:** <http://www.madecal.com.br/biomassa/briquetes/>

### **Briquete São Carlos**

Produces briquettes, wood chips and wood shavings.

**Location:** São Carlos/SP

**Website:** <http://www.briquetesaocarlos.com.br/>

### **Nasa Briquete Ltda.**

Produce briquette, wood chips and firewood.

**Location:** Braco do Norte/SC

**Website:** <http://www.nasabriquetes.com.br>

### **Cezan Embalagens Ltda.**

Produces pallets, wooden boxes, briquettes, wood chips and recycled components.

**Location:** Sacramento/MG

**Website:** <http://www.cezan.com.br/>

### **Opção Verde Resíduos Florestais**

Produces wood chips, wood shavings, firewood and pellets. Also provides forestry operation services as a contractor.

**Location:** Sorocaba/SP

**Website:** <http://www.opcaoverde.com.br/>

**Madegal Madeiras Ltda.**

Produces wood and wood chips for energy generation.

**Location:** General Carneiro/PR

**Website:** <http://www.madegal.com.br/>

## **List of Kesla's competitors in Brazil**

### **Domestic manufacturers**

#### **Fezer (stationary and mobile)**

Manufacturer of stationary and mobile wood chippers and grinders. Fezer exports to United States, Canada, Russia, Germany, New Zealand, Finland, Australia, Slovenia and China.

**Website:** <http://www.fezer.com.br/>

#### **Vantec (mobile)**

Vantec chippers are designed to produce chips from branches, logs and other forest residues. The wood chippers possess a roll-on system which allows the chipper to be easily transported on a truck chassis.

**Website:** <http://www.vantec.ind.br/>

#### **Mill (stationary)**

Mill Drum Chippers are stationary chippers developed to chip flitch, toppings, forestry residue and other kinds of sawmill waste residues. These chippers utilize a vibrating conveyor for feeding.

**Website:** <http://www.mill.com.br/>

#### **Planalto Indústria e Comércio Ltda. (stationary and mobile)**

Planalto manufactures disc and drum chippers with Jenz GmbH technology. Planalto has a wide range of wood chippers consisting of stationary and mobile ones. Planalto has signed a contract with Jenz GmbH for technology transfer and name use for the manufacturing of wood chippers in Brazil. The contract gives also rights to Planalto for selling to other countries in Latin America. The wood chippers production is done through make-to-order with estimated delivery time of 150 days from the request. Part of the wood chipper components are imported and another part is made in Brazil. Imported components are kept in stock for fast delivery when required.

**Website:** <http://www.planaltopicadores.com.br/>

#### **Bruno Industrial (mobile and stationary)**

Bruno Industrial manufactures disc and drum wood chippers. Its range consists of mobile and stationary wood chippers. The company has contract of technology transfer with German Haas Recycling Systems. Bruno Industrial has also partnership with North American CEM Machine, Inc.

**Website:** <http://www.bruno.com.br/>

**Vanmaq (stationary)**

Vanmaq is a national manufacturer of stationary drum chippers. Manufactures also other timber equipment for the market of sawmills, veneer and plywood.

**Website:** <http://www.vantec.ind.br/>

**Serena Máquinas (mobile/stationary)**

Serena Máquinas is a national manufacturer of stationary and mobile chippers. The company markets both disc and drum chippers. Serena Máquinas also manufactures other equipment for wood processing.

**Website:** <http://www.serenamaquinas.com/>

**Menxon (mobile)**

Menxon is a national manufacturer of agricultural attachments and disc chippers.

**Website:** <http://www.menxon.com.br/>

**Nicoletti (mobile/stationary)**

Nicoletti is a national manufacturer of stationary and mobile drum chippers. The company also manufactures other equipment for wood processing.

**Website:** <http://www.nicolettimaq.com.br/>

**Demuth (mobile/stationary)**

Demuth manufactures mobile wood chippers, stationary wood chippers, (both disc and drum) wood chipper knives, log debarkers and other forestry equipment. The company exports to Argentina, Brazil, Chile, Colombia, Germany, Indonesia, Japan, Malasia, Mexico, Portugal, Spain, South Africa, Switzerland, Thailand, USA, Uruguay and Venezuela.

**Website:** [http://www.demuth.com.br/?area=2&mid\\_desc=Demuth&mid=53](http://www.demuth.com.br/?area=2&mid_desc=Demuth&mid=53)

**Lippel (stationary/mobile)**

Lippel has an extensive forestry line/range of equipments and machines. Its wood chipper line consists of stationary drum chippers, mobile drum chippers, stationary disc chippers, mobile disc chippers, branch crushers, grinders, knife sharpeners, chipper knives, log splitters, biomass handling and storage systems, grate biomass boilers, furnaces and biomass drying systems.

**Website:** <http://www.lippel.com.br/>

### **International manufacturers**

#### **JENZ GmbH**

The German JENZ GmbH is present in Brazil through its licensee Planalto Indústria e Comércio Ltda. JENZ GmbH manufactures mobile and stationary chippers, chipper trucks, turning and mixing machines, biomass processors, wood crackers and regrinders.

**Website:** <http://www.jenz.de/>

#### **ECHO Bear Cat**

North American ECHO Bear Cat manufactures wood chippers, chipper shredders, wheeled trimmers and wheel vacuums. ECHO Bear Cat products are imported to Brazil by Engemac. Engemac is a retail company specialized in the sale of different agriculture, handling and construction machinery and equipment.

**Website:** <http://www.engemac.com.br/>

**Website:** <http://www.bearcatproducts.com/>

#### **Mus-Max**

Austrian manufacturer of mobile drum wood chippers. Mus-Max is represented in Brazil by Braflorest. Braflorest is a distributor of forestry equipment including Mus-Max wood chippers.

**Website:** <http://www.braflorest-tec.com/>

**Website:** <http://www.mus-max.at/>

#### **Continental Biomass Industries**

North American manufacturer of wood chippers, grinders and shredders. The company has two offices in the south of Brazil.

**Website:** <http://www.latinequip.com.br>

#### **Vermeer Latin America**

North American manufacturer of wood chippers, horizontal grinders and tub grinders. Vermeer has an office in Brazil which provides sales, marketing, service and parts support for Vermeer customers and dealers. The office also provides support in the development of new products and solutions designed specifically to the needs of Brazilian customers.

**Website:** <http://www2.vermeer.com/vermeer/LA/pt/N/>



**Morbark**

North American manufacturer of mobile whole tree chippers, shredders and other heavy equipment. The Japanese Komatsu Corporation through its subsidiary Komatsu Forest Ltda administers/represents the Morbark line in Brazil.

**Website:** <http://www.komatsuforest.com.br>

**Website:** <http://www.morbark.com/>

**Haas Recycling Systems**

Manufactures stationary drum chippers, crushers and hammermills. The Brazilian company Bruno Industrial manufactures Haas equipment through a license.

**Website:** <http://www.haas-recycling.de/de/>

**CEM Machine, Inc.**

Manufactures stationary disc chippers and feeding systems. The Brazilian company Bruno Industrial manufactures CEM equipment through a license.

**Website:** <http://betiolmaquinas.com.br/produto/detalhe.asp?id=233>

**List of potential partners (wood chipper) for Kesla in Brazil. Models presented on the list are manufactured in Brazil.**

**Trucks**

**Scania**

Manufacturer of trucks, bus chassis and engines.

**Models:** P, G and R series

**Website:** <http://www.scania.com.br/>

**Mercedes Benz**

Manufacturer of trucks, engines and parts.

**Models:** Constellation: 13.180, 15.180, 17.250. Tractor, 17.320, 19.320, 19.370, 24.250. Worker: 8.120, 9.150E, 13.180, 15.180, 15.180 4X4, 17.180, 17.220, 17.220. Tractor Euro III

**Website:** <http://www.mercedesbenz.com.br/>

**Iveco**

Manufacturer of trucks, vans and minibuses.

**Models:** Cavallino, City Class, Cursor, Daily, Eurocargo, Stralis NR, Tector, Trakker, Vertis

**Website:** <http://www.iveco.com/brasil/>

**Volvo**

Manufacturer of Volvo heavy trucks, buses, construction machinery, industrial motors; vehicle financing.

**Models:** VM 210, 260, 310, FM D11A, FMX D11A, D13A, FH 400, 440, 480, 520.

**Website:** <http://www.volvotrucks.com/trucks/brazil-market/pt-br/>

**Ford**

Manufacturer of trucks and minibuses.

**Models:** F-350, F-350CD, F4000, F4000 4X4, C-712, C-815E, C-1317E, C-1517E, C-1717E, C-1722E, C-1832E, C-2422E 6X2, C-2428E 6X2, C-2622E 6X4, C- 2628E 6X4, C6332E 6X4, C-4532E

**Website:** <https://www.ford.com.br/fordcaminhoes/>

### **Agrale**

Brazilian manufacturer of tractors, trucks, vehicles, chassis and engines.

**Models:** 6000, 8500, 8500CD, 8500CE, 8500TR, 9200CE, 13000, 13000 6X2, 13000 Bucket.

**Website:** <http://www.agrale.com.br/caminhoes>

### **Tractors**

#### **Agrale**

Brazilian manufacturer of tractors, trucks, vehicles, chassis and engines.

**Models:** 4000, 5000, 6000 and Industrial.

**Website:** <http://www.agrale.com.br/tratores>

#### **Landini**

Joint Venture between Brazilian Montana and Italian Landini.

**Models:** (40-75 cv), (100 cv), (140-180 cv).

**Website:** <http://www.landini.ind.br/>

#### **Case IH**

*Manufacturer of a wide variety of agricultural equipment.* Brand includes Case, International Harvester, and Farmall.

**Models:** Tractors Farmall (80 and 95), Maxxum (110, 125, 135, 150, 165 and 180), Magnum (220, 240, 270 and 305)

**Website:** [www.caseih.com/brazil](http://www.caseih.com/brazil)

#### **New Holland**

Manufacturer of tractors, combine harvesters, balers, forage harvesters and spayers.

**Models:** VM 210, 260, 310, FM D11A, FMX D11A, D13A, FH 400, 440, 480, 520.

**Website:** <http://agriculture.newholland.com/br/pt/Products/Tractors/>

#### **Green Horse**

Green Horse is the licensee of Chinese tractors Jiangsu Yueda Investment Co. Ltd in Brazil.

**Models:** 204, 254, 454, 454 COMPACT and 754.

**Website:** <http://www.greenhorse.com.br/teaser/>

## **AGCO**

Manufacturer of agricultural equipment.

**Models:** AGCO Allis, Challenger, Fendt, Masey Ferguson, Valtra and AGCO Sisu Power.

**Website:** <http://www.agco.com.br/>

## **Yanmar**

Manufacturer of Agritech tractors utilizing Japanese Yanmar engines.

**Models:** 1030, 1050, 1055, 1145, 1155 and 1175.

**Website:** <http://www.agritech.ind.br/>

## **Tramontini**

Brazilian manufacturer of tractors, microtractors and engines.

**Models:** T3230, T5045 and T8075.

**Website:** <http://www.tramontini.com.br/>

## **Farmer**

Importer of Chinese tractors

**Models:** 2540, 5040 and 8040.

**Website:** <http://www.tratoresfarmer.com.br/>

## **Ursus**

Manufacturer of Ursus tractors utilizing Hindi Mahindra engines.

**Models:** 265, 465, 275, 475, 285, 485, 295, 495.

**Website:** <http://www.ursus.com.br/>

## **Implements**

### **J. de Souza Equipamentos Florestais**

Manufacturer of forestry attachments.

**Website:** <http://www.jdesouza.com.br/>

### **Noma**

Manufacturer of truck trailers including forestry trailers.

**Website:** <http://www.noma.com.br/>

**Guerra**

Brazilian manufacturer of truck trailers, semi-trailers, interlink trailers and container carriers.

**Website:** <http://www.guerra.com.br/>

**Randon**

Brazilian company manufacturer of trucks, trailers and semi trailers, forwarders and back loaders.

**Website:** <http://www.randon.com.br/>

**Hidromáquinas Fort**

Brazilian manufacturer of forestry and recycling cranes.

**Website:** <http://www.guindasteshfort.com.br/>

**TMO**

Brazilian manufacturer of forestry equipment.

**Website:** <http://www.tmo.com.br/>

**Motocana**

Brazilian manufacturer of forestry, agricultural, recycling and industrial handling equipment.

**Website:** <http://www.motocana.com>