

Saimaa University of Applied Sciences
Technology, Lappeenranta
Double Degree Program in Civil and Construction Engineering

Ivan Sled

Protection of wood. Fire tests.

Bachelor Thesis 2012

Contents

Abstract.....	3
1. Basic Terminology.....	4
2. Introduction.....	7
3. General information.....	
4. BT Wood Company information.....	9
5. European Regulations.....	11
6. Fire Retardants Tests According to European Regulations.....	12
6.1 Cone Calorimeter Test.....	12
6.2 SBI test.....	13
6.3 Correlation of cone calorimeter and SBI test results.....	17
6.4 Prediction of the heat release rate.....	18
6.5 Small flame test.....	19
6.6 Radiant panel test.....	12
7. Russian Testing Methods and standard system.....	21
7.1 Fire retardant compositions and substances for wood. General requirements..	21
7.2 Testing methods.....	22
7.3 Aging testing method.....	24
7.4 Quality testing methods.....	25
7.5 Common technical guidelines for all chemical products realized in Russian..... Federation	31
7.6 Correspondence Conformation of the products according to technical federal.. law of Russian federation	33
8. Conclusion.....	35
Appendices	
Appendix 1	Example of Small flame test results report
Appendix 2	Example of Radiant panel test report
Appendix 3	Example of Russian Material Safety Data Sheet

Abstract

Ivan Sled

Protection of wood. Fire tests.

46 pages, 3 appendices

Saimaa University of Applied Sciences, Lappeenranta

Technology, Degree in Civil and Construction Engineering

Structural Engineering

Instructors: Timo Lehtoviita, Saimaa University of Applied Sciences,

CEO, Timo Reisto, BT Wood Ltd.

Vice President, Jari Kukkonen, BT Wood Ltd.

The main purpose of the study was to give information about fire testing methods and classification system in Russian Federation and Post- Soviet Union Countries.

Various aspects of assessing the fire safety of construction products related to the initiation and development of fire and the determination of toxic smoke gases have been studied. The primary objective has been to provide new information on the subject in the context of the harmonized European fire classification system as well as related to more general fire safety aspects.

Two models for predicting the results of a European intermediate-scale reaction- to-fire test, the SBI test, have been introduced.

The fire test methods and classification parameters of the Russian and European fire classification systems of surface linings are different. Owing to the common reference scenario, the classification systems are still strongly consistent for the majority of products. Inconsistencies can be recognized by examining the product type and composition and by considering the special features of the main fire tests used in the classification. Modeling of SBI test results on the basis of cone calorimeter data provide a link between the Russian and European fire classification systems.

Keywords: fire test, combustion, cone calorimeter, single burning item, radiant panel, classification, wood, fire retardant

1. Basic Terminology

Combustible , adj.	Capable of being combusted
Combustible , noun	Item capable of combustion
Combustion	Exothermic reaction of a substance with an oxidizer
Fire	(Controlled) self-supporting combustion which has been deliberately arranged to provide useful effects and which is controlled in its extent in time and space
Fire behaviour	Change in the physical and/or chemical properties an item and/or structure exposed to fire
Fire compartment	Enclosed space, which may be subdivided, separated from adjoining spaces within the building by elements of construction having a specified fire resistance
Fire effluent	Totality of gases and/or aerosols (including suspended particles) created by combustion or pyrolysis
Fire exposure	Extent to which persons, animals or items are subjected to the conditions created by fire
Fire hazard	Potential for injury and/or damage from fire
Fire performance	Response of an item when exposed to a specific fire cf. fire behaviour
Fire resistance	Ability of an item to fulfil for a stated period of time the required stability and/or integrity and/or thermal insulation, and/or other expected duty specified in a standard fire resistance test NOTE "Fire resistant" (adjective) refers only to this ability
Fire retardant , noun	Substance added, or a treatment applied, to a material in order to delay ignition or to reduce the rate of combustion NOTE The use of fire retardants does not necessarily suppress fire
Fire scenario	Detailed description of conditions, including environmental, of one or more stages from before ignition to after completion of combustion in an actual fire at a specific location or in a real-scale simulation
Flame , noun	Zone of combustion in the gaseous phase, usually with emission of light
Flame , verb	To undergo combustion in the gaseous phase with emission of light
Flame front	Boundary of flaming combustion at the surface of a material or propagating through a gaseous mixture
Flaming combustion	Combustion in gaseous phase, usually with emission of light
Flash-over	Transition to a state of total surface involvement in a fire of combustible materials within an enclosure

Fully developed fire	State of total involvement of combustible materials in a fire
Heat release	Thermal energy which is released by the combustion of an item under specified conditions
Ignition	Initiation of combustion NOTE The term "ignition" in French has a very different meaning [state of body combustion]
Integrity	Ability of a separating element when exposed to fire on one side, to prevent the passage of flames and hot gases or the occurrence of flames on the unexposed side, for a stated period of time in a standard fire resistance test
Pyrolysis	That part of the irreversible chemical decomposition caused solely by a rise in temperature
Reaction to fire	Response of a material in contributing by its own decomposition to a fire to which it is exposed, under specific conditions
Smoke	Visible part of fire effluent
Temperaturetime-curve (standardized)	Time-related variation of temperature prescribed in a specified way during a standard fire resistance test

2. Introduction

B.T Wood Company is interested in expansion to the market of Russian Federation and Post- Soviet union countries with their products. The purpose of this thesis was to provide the information about Russian fire tests, certification of products in Russia, classification of chemicals used as wooden preservatives. The scope of thesis is to show general difference between EU and Russian Federation testing methods and certification system.

3. General Information

Wood has many excellent natural properties. Wood is nature's most versatile building material. It is renewable, sustainable, energy efficient to harvest and convert to a usable component, easily workable, has minimal environmental pollution, warm in use, aesthetically pleasing and has a range of excellent physical and mechanical properties.

Purpose fire retardants usage

Use of wood can be restricted by safety requirements and regulations concerned with its ignitability and fire spreading characteristics.

The careful selection of the correct type of fire retardant formulation can overcome this concern and allow a wide range of fire retardant wood based products to comply with even the most stringent regulations, thus extending the market use of this most natural of building materials.

Fire retardant treatment of wood can firstly delay the ignition for a meaningful time and secondly lower the heat release rate after ignition. Both of these effects together do strongly affect the potential for spreading fire beyond the location of original ignition. In a room fire test (ISO 9705) this is seen in following way: Untreated wood goes to flashover in about 3 minutes, but FR wood may prevent flashover even 20 minutes or more.

FR Chemicals

It is relatively easy to obtain an improved fire performance of wood products. Most existing fire retardants are effective in reducing different reaction-to-fire parameters of wood such as ignitability, heat release and flame spread. The highest European and national fire classifications for combustible products can be reached. However, high retention levels have to be used compared to ordinary preservation treatments used to protect wood against biological decay.

Flame retardant treatments for wood are numerous and can be classified into three general classes:

- those incorporated integrally into wood composite products during manufacture

- those pressure impregnated into solid wood, plywood, particleboard and hardboard industrially, but after manufacture
- those applied, as paints or surface coatings, in-situ after wood based products are installed

Formulations

Although manufacturers maintain a mystique about their formulations, the actual flame retardant chemicals have a long history of use for this purpose. These chemicals include those based on phosphorus, nitrogen, boron, silica and their combinations where the behavior can be synergistic.

Examples are:

- mono-ammonium phosphate
- di-ammonium phosphate
- ortho-phosphoric acid
- ammonium sulphate
- borax/boric acid/boric oxide/disodium octoborate
- melamine phosphate

Chemicals effect

Flame retardant chemicals work in several ways. Some of these include:

- promotion of char formation
- conversion of volatile gases to non-ignitable gases such as water vapor and carbon dioxide.
- forming a glaze barrier at the surface
- forming an intumescent foam barrier at the surface
- free radical termination in the gaseous phase

In all instances they are formulated and applied to control ignition, flame spread across a wooden surface, and to lower the rate of heat release from the wood based substrate.

Flame retardants cannot make wood noncombustible.

Making a choice

The choice of chemical or in reality FR formulation which the specifier or user chooses is dependent on several factors and it is important to discuss these in some detail with suppliers and manufacturers so that potential service life problems are eliminated.

Factors include:

- type of wood based substrate
- regulatory requirement to be satisfied
- new build or maintenance/upgrade
- service life conditions/environment
- installation conditions
- maintenance requirements
- effects, if any, of the FR treatment on appearance or other natural or inherent properties of the substrate.

Fire retardant wood and wood based panel products are being used in a wide variety of market areas. The fire retardant treatment, if correctly specified, provides added value to the wood based substrates and extends the market potential of the world's most natural building material.

Conditions of Use

The environment in which the Fire Retardant Treated Wood (FRTW) is to be used has great influence on the choice of FR treatment and formulations. High humidity or wet conditions can affect both the fire performance of certain treatments and lead to certain undesirable side effects such as strength reduction, corrosion of metal fixings, decay and problems with overpainting.

Characteristics of FR-formulations:

1. inorganic salt type for dry interior use only
2. humidity resistant chemical types for all interior uses and some weather protected exterior uses
3. leach resistant polymer types for fully exposed exterior situations

Intumescent coatings are generally only suitable for dry interior uses. This applies particularly to clear lacquers.

Durability of Fire Retardant Treatment

The environment in which the Fire Retardant Treated Wood (FRTW) is to be used has great influence on the choice of FR treatment and formulations. High humidity or wet conditions can affect both the fire performance of certain treatments and lead to certain undesirable side effects such as strength reduction, corrosion of metal fixings, decay and problems with over-painting.

Characteristics of FR-formulations:

- a) inorganic salt type for dry interior use only
- b) humidity resistant chemical types for all interior uses and some weather protected exterior uses
- c) leach resistant polymer types for fully exposed exterior situations

Intumescent coatings are generally only suitable for dry interior uses. This applies particularly to clear lacquers.

4. BT Wood company information

BT Wood Ltd is a rapidly growing innovative company specialized in development and marketing of novel wood treatment chemicals. The operations are located in the capital area in Espoo and in northern Finland in city of Oulu.

The core business is to provide construction companies and timber manufacturers with new sustainable and efficient chemicals for treatment of wood, thus enabling them extensive use of wood as a building material. This way companies favor strongly the shift from environmentally harmful materials towards sustainable, low carbon dioxide emission wood construction materials. B.T. Wood works in a wide R&D network and continuously develops new solutions for company customers, offering them also consultancy to fine tune their industrial processes to utilize the new products in a safe and cost-efficient way.

BT wood products:

Fire retardants

BT Wood® One is a safe and cost-effective fire retardant for all kinds of wood. It can be applied either by surface treatment methods or by light impregnation. BT Wood® One treated wood can be after treated either with a lacquer, paint or with BT Wood® Coat.

This product is aimed to replace fire retardants, that require full impregnation process (high cost) and contain toxic or harmful (e.g. borax) anti-fire compounds. BT Wood® One is specially designed for routine industrial treatment processes, making them easy and cost-efficient. Also process wastes can be desolated safely.

BT Wood® One treated plywood has recently got an EU-certification for excellent class B fire protection.

Optimal application targets are e.g. structural elements in wood buildings, glulam, plywood and LVL and boardings used both inside and outside.

Industrial preservatives

Industrially infused preservatives in timber, plywood and other wood-based products add remarkably years to the predicted service life of these materials in different

applications. BT Wood® Industrial Preservatives are applied by vacuum-, pressure impregnation- or immersion methods.

A specialty polar organic, waterborne BT Wood® Preservative is a heavy metal free and non-toxic chemical. It guarantees a long-term protection against fungi, blue stain and insect attack without damaging our natural environment. Wood protected with BT Wood Preservative can be further treated with BT Wood® Coat or other commercial surface treatment products.

Typical places to apply BT Wood® Preservative are e.g. decking, exterior sidings, poles, fences and other structural wood elements.

Surface treatment solutions

Untreated or even pressure impregnated wood, after weather-exposure, may crack and be damaged by different degrading factors. To avoid these inconveniences and ensure superior resistance of wooden products protection is needed.

BT Wood® Coat treated surface is easily cleanable. It suits to sites where durability and good outlook is a requirement. The characteristics of the surface can be modified by adjusting the treatment procedure. A very thin layer of BT Wood® Coat is applied by spraying or brushing.

The coated surface can also be colored in a pre-treatment procedure or pre-treated with e.g. BT Wood® One fire retardant or BT Wood® Termite.

BT Wood® Coat is an optimal choice e.g. in wood paneling, boards, wooden doors and frames, handrails, benches etc.

Anti-termite agent

Untreated or even pressure impregnated wood, after weather-exposure, may crack and be damaged by different degrading factors. To avoid these inconveniences and ensure superior resistance of wooden products protection is needed.

BT Wood® Coat treated surface is easily cleanable. It suits to sites where durability and good outlook is a requirement. The characteristics of the surface can be modified by

adjusting the treatment procedure. A very thin layer of BT Wood® Coat is applied by spraying or brushing.

The coated surface can also be colored in a pre-treatment procedure or pre-treated with e.g. BT Wood® One fire retardant or BT Wood® Termite.

BT Wood® Coat is an optimal choice e.g. in wood paneling, boards, wooden doors and frames, handrails, benches etc.

5. European Regulations

A new classification system for the reaction to fire properties of building construction products has been introduced in Europe by COMMISSION DECISION (2000/147/EC) of 8 February 2000 implementing Council Directive 89/106/EEC (Ref. OJ L 50, 23.2.2000).

It is often called the Euroclass system and consists of two sub-systems, one for construction products excluding floorings, e.g. wall and ceiling surface linings, see the table below, and another similar system for floorings. Both sub-systems have classes A to F of which classes A1 and A2 are noncombustible products. The new system is replacing the earlier national classification systems, which have formed obstacles to trade.

Table 1 Euroclass system, construction products.

Euroclass	Smoke class	Burning droplets class	Requirements according to EN fire tests			FIGRA W/s	Typical products
			Non. comb	SBI	Small flame		
A1	-	-	x	-	-	-	Stone, concrete
A2	s1, s2 or s3	d0, d1 or d2	X	x	-	≤ 120	Gypsum boards (thin paper), Mineral wool
B	s1, s2 or s3	d0, d1 or d2	-	x	X	≤ 120	Gypsum boards (thick paper), Fire retardant wood
C	s1, s2 or s3	d0, d1 or d2	-	x	x	≤ 250	Coverings on gypsum boards
D	s1, s2 or s3	d0, d1 or d2	-	x	X	≤ 750	Wood, wood-based panels
E	-	- or d2	-	-	X	-	Some synthetic polymers
F	-	-	-	-	-	-	No performance determined

SBI= Single Burning Item, main test for the reaction to fire classes for building products;
 FIGRA= Fire Growth Rate, main parameter for the main fire class according to SBI test.

6. Fire Retardants tests according to European regulations.

6.1. Cone calorimeter test

This chapter is based on information, which is given in standard. (ISO 5660-1)

The cone calorimeter test ISO 5660-1 is a bench-scale fire test method for assessing the contribution that the product tested can make to the rate of evolution of heat during its involvement in fire. The main parts of the apparatus are a cone-shaped radiant electrical heater with a temperature controller, a spark igniter, a weighing cell, a specimen holder, and an exhaust gas system. A schematic picture of the cone calorimeter is presented in Figure 1.

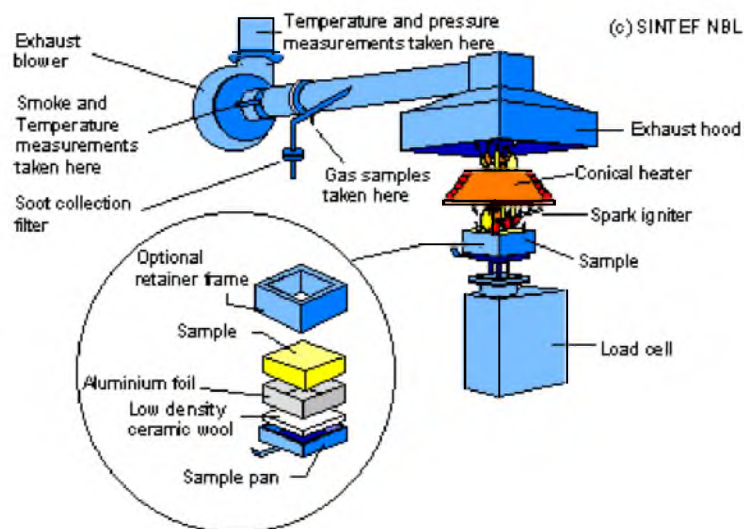

Figure 1 A schematic picture of the cone calorimeter. (SINTEF NBL, 2006)

Test specimen

The test specimen has an area of 100 mm × 100 mm and a maximum thickness of 50 mm.

In a standard test, the specimen in the specimen holder is positioned under the cone-shaped heater on the weighing cell. The orientation of the specimen can be either horizontal or vertical, the horizontal orientation being more common in standard testing. The combustion products flow through the top opening of the heater into the hood and the exhaust duct from which a gas sample is taken for gas analysis.

Measurements

The main measurements of the test are:

- Time to ignition
- Mass loss
- Heat Release rate (based on oxygen consumption calorimetry)
- Effective heat of combustion

The highly uniform irradiance over the entire specimen surface and the possibility of measuring quantities per unit area and mass of the material tested make the cone calorimeter an excellent instrument for determining material parameters and for other scientific purposes. Naturally, the full-scale effects of products and structures cannot be revealed in cone calorimeter tests due to the small size of the specimen.

6.2. SBI test

This chapter is based on information, which is given in standard. (EN 13823:2002)

The single burning item (SBI) test is a new fire test method developed for the forthcoming Euroclass system by a group of European fire laboratories on the basis of the specifications defined by a group of European fire regulators. The development work included the design of a prototype, the installation of test facilities, the determination of the accuracy of the method and the production of data needed to finalize the classification system.

The SBI test is based on a fire scenario of a single burning item, for example a wastebasket, located in a corner between two walls covered with the surface lining to be tested. The SBI test apparatus is shown schematically in Figure 2.

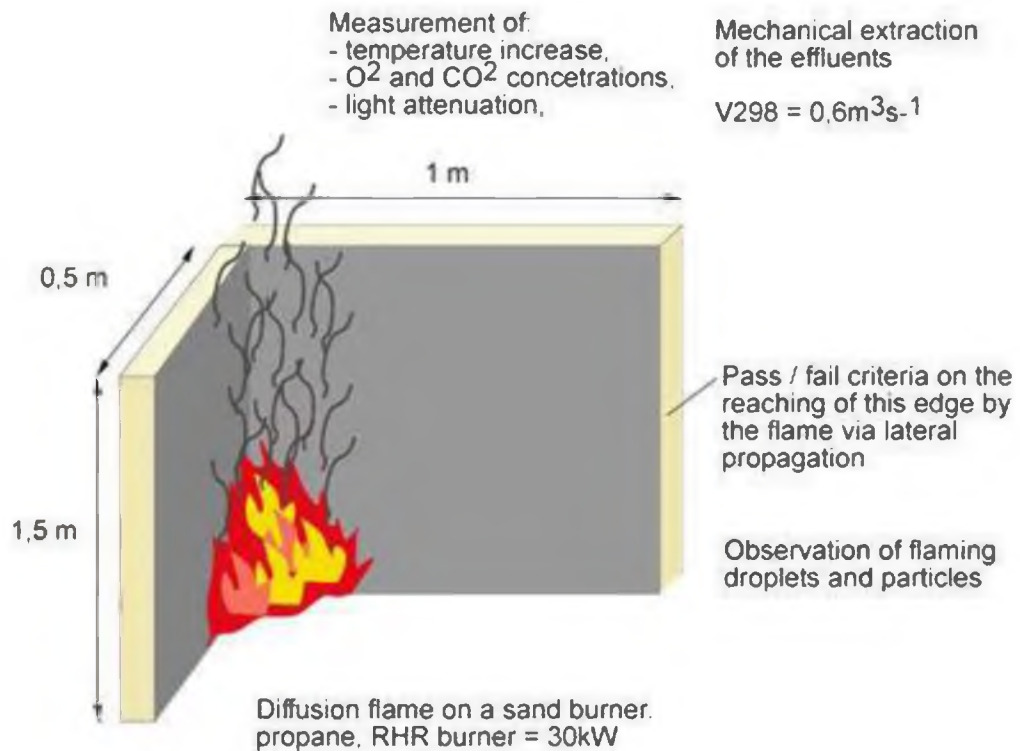

Figure 2 A schematic picture SBI (Single Burning Item) test. (Sandwichbau, 2000)

Test specimen

The SBI test specimens are installed on a specimen holder consisting of two vertical wings made of non-combustible board. The specimen holder wings of sizes 1.0 m × 1.5 m and 0.5 m × 1.5 m form a right-angled corner configuration.

The thermal exposure on the specimen surface is produced by a triangle-shaped propane gas burner placed at the corner formed by the specimen wings. The heat output of the burner is 30 kW resulting in an average maximum heat exposure of about 40 kW/m² on an area of approximately 300cm². The burner simulates a single burning item.

Material consumption during test

- Complete test, 3 tests
 - 5 test samples with the dimension 1.00 m x 1.50 m (long wing)
 - 5 samples with the dimension 0.49 m x 1.50 m (short wing)
- Indicative test, 1 test
 - 1 test sample with the dimension 1.00 m x 1.50 m (long wing)
 - 1 sample with the dimension 0.49 m x 1.50 m (short wing)

Measurements

The SBI test is performed under a hood. The combustion gases are drawn to an exhaust duct equipped with sensors to measure the temperature, light attenuation, O_2 and CO_2 mole fractions and flow-induced pressure difference.

The heat release is determined using oxygen consumption calorimetry.

The smoke production is measured on the basis of the attenuation of light by combustion gases.

In addition, lateral flame spread and the occurrence of flaming droplets or particles are visually observed.

Conclusion

The classification parameters of the SBI test are:

- Fire growth rate index (FIGRA),
- Lateral flame spread (LFS),
- Total heat release during the first 600 seconds of the test (THR_{600s}).

Additional classification is defined:

- Smoke growth rate index (SMOGRA)
- Total smoke production (TSP_{600s})
- Flaming droplets and particles according to their occurrence and burning time during the first 600 seconds of the test.

For determining FIGRA, the measured values of the heat release rate are divided by the corresponding times of measurement.

FIGRA is the maximum value of this quotient. To prevent signal noise in the early part of the test from having a determining effect on the classification,

FIGRA is calculated from smoothed data and threshold values of the heat release rate (HRR) and total heat release (THR) are used to initiate the calculation.

Models for predicting SBI test results

Since the development of the SBI test method, correlations between the cone calorimeter and SBI test results have been subject to increasing interest. The SBI test is relatively costly: for a single test, more than $2m^2$ of specimen material is needed, and the operating costs of the intermediate-scale test apparatus increase the price. The cone calorimeter is a well-established small-scale fire test method, requiring only a small piece ($0.01m^2$) of specimen material. Thus, models predicting the results of SBI tests on the basis of cone calorimeter data provide economical tools for product development and quality control, even though the SBI test is required in the actual classification. Two methods for predicting the SBI test results of a construction product on the basis of cone calorimeter data are presented below. (Kokkala, 1997)

One-dimensional thermal flame spread model

The one-dimensional thermal flame spread model for upward flame spread on wall linings can be applied to the SBI test. The input data of the model are rate of heat release curves from cone calorimeter tests performed at the heat exposure level of $50 kW/m^2$. The starting point of the calculation is Equation, the one-dimensional differential equation describing upward flame spread. The flame spread is determined by solving the initial value problem of Equation. $Q(t)$ is calculated as the sum of the contributions of the burner and the material. The heat release rate of the material is

$$\dot{Q}_{mat}(t) = x_{p0}w\dot{q}''(t) + \int_{\tau=1}^{\tau=t} \dot{q}''(t-\tau) \frac{x_f(\tau)-x_p(\tau)}{t_{ig}} d\tau \quad (1)$$

where w and x_{p0} are the width and initial height of the pyrolysis area, and $\dot{q}''(t)$ and t_{ig} are the heat release rate (HRR) curve and the ignition time from the cone calorimeter test, respectively.

The ignition time is determined from the *HRR* curve as the time when the heat release rate per unit area reaches $50 kW/m^2$, which is in good agreement with visual observations. This method to determine the ignition time, however, is more objective than visual perception. To apply the model to predicting SBI test results, the input parameters x_{p0} , w , k_f and were determined and optimized by examining the features of the SBI test arrangement and based on model tuning. In addition, input data from cone

calorimeter tests run at the exposure level of 50 kW/m^2 were scaled to lower levels selected on the basis of practical experience and model tuning.

The model was optimized using particle board as a tuning material. In the tuning, there were two aspects of major importance: the shape of the predicted HRR curve and the resulting FIGRA value determining the classification. It was found that reproducing the shape of the HRR curve throughout the whole SBI test is unrealistic with this model. However, the early stage of the test can be predicted well for several types of materials. In general, the height and shape of the first HRR peak in the SBI test determine the FIGRA value. The most interesting stage of the test is therefore its early part including the first major HRR peak. $\text{THR}_{600\text{s}}$ is used as another heat release classification quantity, but FIGRA determines the class in most cases. Thus, successful modeling of the first peak of the SBI heat release rate curve is usually adequate to predict the classification of a building product correctly.

In many cases, the flame front spreads on the surface of an SBI test specimen both vertically and laterally. The one-dimensional model applied takes into account only the vertical direction, but the effect of the lateral flame spread can be compensated to some extent by the selection of the input parameters and the way of using the HRR curve from the cone calorimeter test. As a result of calculations according to Equations the predicted heat release rate curves of SBI tests are obtained. From these curves, FIGRA values determining the product classification can be calculated.

Model based on rate of heat release and ignitability indices

In this method, FIGRA predictions are calculated from a regression equation on the basis of ignitability and rate of heat release indices (I_{ig} and I_Q , respectively) obtained from cone calorimeter data measured at the heat exposure level of 50 kW/m^2 . The equations for the indices are the following:

$$I_{ig} = 1/t_{ig} \quad (2)$$

$$I_Q = \int_{t_{ig}}^{t_{end}} \left[\frac{\dot{q}''(t)}{(t-t_{ig})^m} \right] dt \quad (3)$$

where t_{ig} - is the time to ignition, t_{end} the end time of the test and m a constant.

The denominator of the integrand represents a weighting function that gives a higher importance to the values of the heat release rate immediately after ignition than to those occurring later. Originally, the indices were developed for predicting the performance of surface linings in the ISO 9705 Room/Corner test. Since the basic fire growth processes in the initial stages of the tests are similar, the index approach can be applied to the prediction of SBI test results. Due to the different parameters to be predicted, however, the weighting of the HRR curve (i.e. the value of m) used as input is different. In order to base the index approach to the SBI test on a wide range of ignition and heat release behavior and on a sufficient amount of data, a series of over 200 artificial cone calorimeter data files for hypothetical products was generated. The shape of the HRR curve was assumed to be of the form

$$\dot{q}''(t) = \dot{q}''_{max} (t/t_{max}) \exp \left[-(t/t_{max} - 1) \right] \quad (4)$$

where $\max \dot{q}''$ is the peak value of the heat release rate per unit area occurring at time t_{max} .

This functional form was chosen because a wide range of products exhibits this curve shape in the initial part of the cone calorimeter test. Similarly to the one-dimensional thermal flame spread model, t_{ig} was determined as the time when the heat release rate per unit area reaches 50 kW/m^2 . The selection of t_{ig} defines a time shift to the beginning of the HRR curve. The ranges for the parameters were $55\text{--}700 \text{ kW/m}^2$ for $\max \dot{q}''$, $5\text{--}60 \text{ s}$ for t_{max} , and $5\text{--}60 \text{ s}$ for t_{ig} , corresponding to the typical behavior of construction products in cone calorimeter tests at an irradiance level of 50 kW/m^2 .

The FIGRA values for the hypothetical products were calculated by predicting the HRR curves of the SBI test using the one-dimensional thermal flame spread model described above. The generated data files were used for finding an expression for FIGRA as a power law of t_{ig} , \dot{q}''_{max} and t_{max} . On the basis of the exponents found by least squares fitting, the value of $m = 0.89$ was selected for the calculation of the I_Q index as shown in the Appendix of Paper II. Finally, another fit was performed in order to express FIGRA as a power law of I_{ig} and I_Q . The resulting regression equation is

$$FIGRA = 2.7 \cdot 10^{-4} I_{ig}^{0.93} I_Q^{1.85} \quad (5)$$

where I_Q is calculated with $m = 0.89$ according to Equation and the unit of I_{ig} is min^{-1} .

It is noted that the selected ranges of \dot{q}''_{max} , t_{max} and t_{ig} limit the validity range of the model. The prediction according to Equation (16) should not be used for products outside the validated range due to the increased uncertainty of the predicted FIGRA values.

The THR threshold values normally used in the FIGRA calculation according to prEN 13823 were ignored in the model development for analogy because the calculation of the rate of heat release index does not include any THR threshold. However, a corresponding regression equation can also be found for FIGRA values determined using the THR thresholds.

6.3. Correlation of cone calorimeter and SBI test results

In the previous paragraph, two models for predicting the results of the SBI test on the basis of cone calorimeter data are introduced. The one-dimensional thermal flame spread model can be used to predict the first peak of the heat release rate curve of a product in the SBI test. Estimates of the FIGRA value and the classification can be determined on the basis of the predicted curve. The model based on rate of heat release and ignitability indices predicts the FIGRA value and the classification using a simple regression equation. However, the heat release behavior of a product cannot be estimated using this approach.

6.4. Prediction of the heat release rate

A series of graphs comparing the measured HRR curves against those predicted was obtained using the one-dimensional thermal flame spread model. This model is incapable of reproducing the shape of the HRR curve throughout the whole SBI test, but the first HRR peak can be predicted relatively well. Prediction of the first peak is usually adequate for predicting the classification of a product correctly, since the early part of the test is of major importance determining the FIGRA value.

Investigation of the modeled heat release rate curves revealed three product groups: basic wood products, wood products with a surface layer, and products with a surface layer on a non-combustible substrate.

For basic wood products, the model predicts the first peak of the HRR curve reasonably well. The predicted heat release rates for wood products with a surface layer tend to be delayed and smoothed compared to the SBI measurements. Products composed of a surface layer on a non-combustible substrate show two types of behavior depending on the thickness of the surface layer. If the surface layer is thin, the calculated HRR curve exhibits a sharp peak in the beginning of the test. In the SBI test, this peak (if observable) is lower and smoother, and it usually occurs earlier than predicted. If the surface layer is thicker, the predicted peak is both wider and more consistent with the SBI measurement.

Outside these groups there are some products for which the modeling is unsuccessful, owing either to the limitations of the model or to the different features of the SBI and cone calorimeter test methods. For materials exhibiting extensive flame spread, the compensation procedures of the one-dimensionality of the model are inadequate. The model involves assumptions for the scaling of the ignition time and the width of the pyrolysis area that are not optimal for fire retarded materials. For materials that melt, and for products with a reflective coating, the predictions are unsuccessful because the SBI apparatus and the cone calorimeter have different heat transfer modes and different test arrangements with regard to the specimen orientation and the ignition source.

6.5. Small flame test

This chapter is based on information, which is given in standard. (ISO 11925-2:2010)

The apparatus is based on the German Kleinbrenner method for determining ignitability of building products in the vertical orientation by direct small flame impingement under zero impressed irradiance.



Figure 3. A schematic picture of Small Flame test apparatus. (FTT, 2011)

Measurements

The test takes place inside a test chamber where the test specimen is mounted vertically. The test specimen is subjected to edge and/or surface exposure from a gas flame.

Material consumption during test

- Complete test, 12 tests, specimen dimensions 90 mm x 250 mm
 - 9 specimens in one direction (e.g. production direction)
 - 9 specimens in perpendicular direction to the first direction

- Indicative test, 4 tests specimen dimensions 900 mm x 250 mm
 - 2 specimens in one direction (e.g. production direction)
 - 2 specimens in perpendicular direction to the first direction

Procedure

The test takes place inside a test chamber where the test specimen is mounted vertically. The test specimen is subjected to edge and/or surface exposure from a gas flame. During the test, time of ignition, burning droplets and whether the flames reach the top marking of the test specimen within a prescribed time period, is registered.

The main features of test apparatus are:

- An extensively adjustable burner assembly, mounted on runners, to enable the small premixed flame to be tilted at an angle of 45° to the specimen and offered to it in one fluid movement.
- Specimen holder capable of housing the specimens up to and including 60 mm thick.
- A fully adjustable specimen support frame facilitating lateral movement of the specimen holder so that the flame can be applied either at the specimen center position, or at laterally spaced points.
- A digital anemometer/thermometer and a stopwatch for simple but accurate measurement of the flow, temperature and time

The following data are registered:

- time of ignition
- burning droplets

6.6. Radiant panel test

This chapter is based on information, which is given in standard. (ISO 9239-1:2010)

EN ISO 9239-1:2002 describes a European test procedure for assessing the burning behavior, spread of flame and smoke development of horizontally mounted floor covering systems exposed to a radiant heat gradient in a test chamber, when ignited with a pilot flame. The measurements provide a basis for estimating one aspect of fire exposure behavior of floor covering systems. The imposed radiant flux simulates the thermal radiation levels likely to impinge on the floors of a building whose upper surfaces are heated by flames or hot gases or both, from a fire in an adjacent room or compartment.

This method is applicable to all types of floor coverings such as textile carpet, cork, wood, rubber and plastic coverings as well as coatings. Results obtained by this method reflect the performance of the total floor covering system as tested. Modifications of the backing, bonding to a substrate, underlay, or other changes to the system may affect the test results.

Flame spread, smoke production and the heat flux towards the flooring surface that is essential for flame spread is measured according to the test method.

Material consumption during test

- Complete test 4 tests, specimen dimensions 230 mm x 1050 mm.
 - 5 specimens in one direction (e.g. production direction)
 - 5 specimens in perpendicular direction to the first direction
- Indicative test 1 test, specimen dimensions 230 mm x 1050 mm
 - 2 test specimens

Test procedure

The test specimen is placed in a horizontal position below a gas-fired radiant panel inclined at 30° where it is exposed to a defined heat flux. A pilot flame is applied to the hotter end of the specimen. Following ignition, any flame front which develops is noted and a record is made of the progression of the flame front horizontally along the length of the specimen in terms of the time it takes to spread to defined distances.

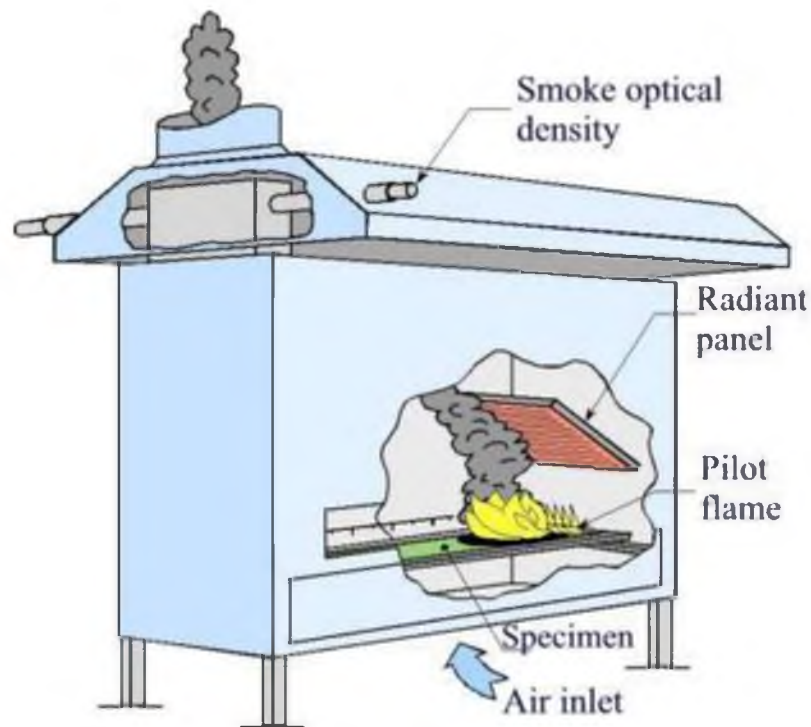

Figure 4. A schematic picture Radiant panel test apparatus. (FTT, 2011)

Smoke production during the test is recorded as light transmission in the exhaust stack. One specimen is tested in one direction (e.g. production direction) and one specimen in the direction perpendicular to the first test. The test which yields the worst results is repeated twice in that direction, i.e. a total of four tests.

7. Russian Testing Methods and standard system

7.1. Fire retardant compositions and substances for wood. General requirements. Test methods.

Classification of Fire retardants

Depending on the contents FR are divided into the following types:

- Fire retardant lacquer
- Fire-retardant paint

- Fire-resisting coating
- Fireproof dope
- Complex fireproofing composition

Depending on application conditions FR are divided into:

- external end-use conditions
- close unheated spaces
- application in close heated spaces
- meant for other specially mentioned end-use conditions application

All the mentioned fire-retardant types depending on excited environment influence are divided into persistent and non-persistent agents.

Depending on the application technique FR is classified as surface treatment and penetration treatment.

Requirements for the content of FR Technical documentation

Technical documentation requirements according to GOST 2.144:

- Type and application conditions have to be pointed out according to classification of Fire Retardants.
- Fire retardant efficiency value and life span in the recommended conditions have to be included in the basic properties and characteristics
- controlled variable and characteristics, along with periodicity of checkout in manufacturing conditions and application conditions, that are defined from quality and characteristics stability of Fire retardant
- information about grade, application technology and application conditions of additional compositions or specification if using is acceptable
- guaranteed storage life and guaranteed service life is recommended to be shown in manufacturer warranty section

7.2. Testing methods

Method of defining the fireproofing efficiency

The following equipment is needed for this testing: Ceramic pipe apparatus, weighing system (accuracy class III), timing device (accuracy class II), gas burner, vent hood with constrained ventilation, container for treating the specimens, aluminum foil with thickness from 0,014 to 0,018 mm, equipment for treating specimen using spray method, swabs and trowels, exsiccator, zinc nitrate 6-aqueous.

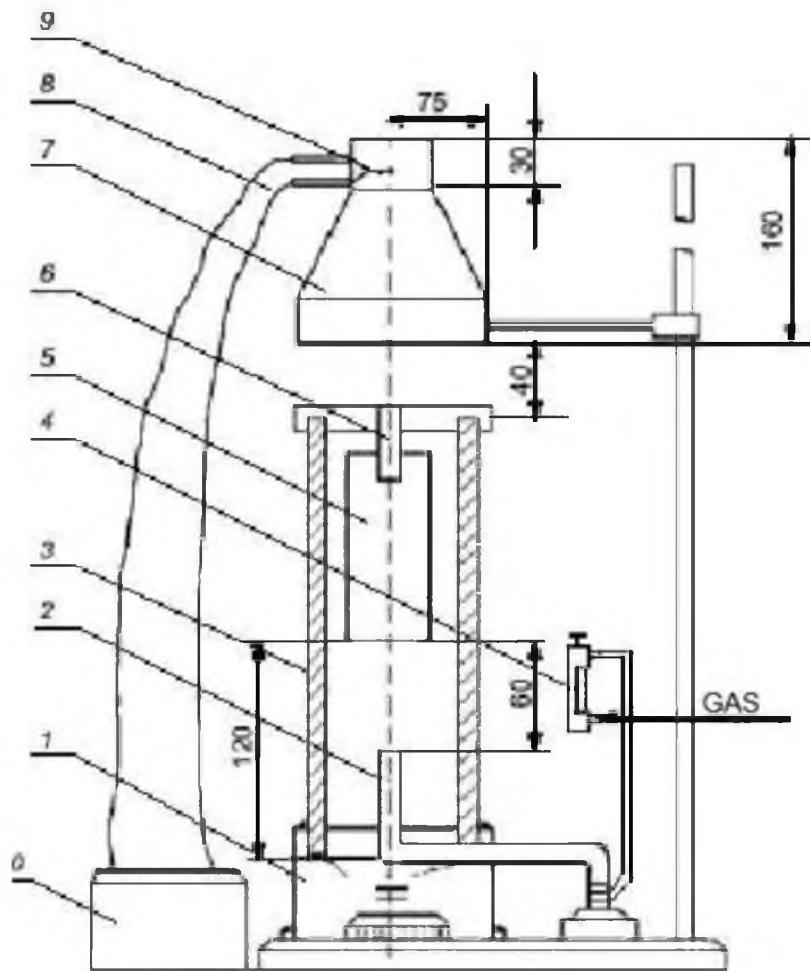

- 1-Support platform; 2- Gas burner; 3- Ceramic hamper; 4- Rotameter; 5- Specimen; 5- Specimen holder; 6-Bonnet; 7- thermoelectric transducer; 8- upper jet of bonnet; 9- automatic potentiometer

Figure 5. The testing apparatus called "Ceramic pipe" (GOST 2.144)

Specimen for test

Specimens have to be made of straight-grained air-dry spruce wood with 8-15% humidity level and density from 400 to 550 g/m³ in rectangular form with cross section

of 30×60 mm and length along the grain 150 mm, deviation from the reference dimensions should not exceed 1 mm.

The test is taken from the minimum of 10 test specimens.

Classification

Classification is given from the results of the test and the following calculation of mass loss of the specimens.

- Mass loss $\leq 9\%$ - The | class of Fire Retardant efficiency is given.
- $9\% \leq \text{mass loss} \leq 25\%$ - The || class of fire retardant efficiency is given.
- Mass loss $\geq 25\%$ - this treatment is not providing the fireproofing effect and is not the fire retardant.

The mass loss (P_i , %) is calculated using following equation:

$$P_i = \frac{(m_{1i} - m_{2i})}{m_{1i}} \times 100, \quad (6)$$

Where m_{1i} - Mass of specimen before testing, in grams;

m_{2i} - Mass of specimen after testing, in grams;

i- Number of specimen.

The result of calculation is approximated to 0,1%.

After testing the average value of 10 tested specimens have to be defined. For the specimens that fail the linear inequalities [7] and [8] the new specimens are taken and tested and the average value has to be defined again.

$$|P_{av} - P_i| \leq 3 \text{ if } P_{av} \leq 9; \quad (7)$$

$$|P_{av} - P_i| \leq 5 \text{ if } P_{av} \leq 25, \quad (8)$$

Where P_{av} - Average value of mass loss from 10 tested specimens, in percent;

P_i - Value of mass loss taken from 1 specimen (from 10), in percent.

7.3. Aging testing method

The essence of this method is to define the conservation of fire retardant treatment efficiency after accelerated aging as the result of temperature and humidity change in alternate mode, which is done in the predetermined sequence.

Specimen

The specimens are the same sizes as in the previous test. For the test 6 specimens are used.

Measurements and test

Three of them are called control samples; they are treated with fire retardant as in the previous test. And mass loss of those specimens is defined as in previous test. It is taken the average value of mass loss from the results of 3 specimens (P_k , %).

Three main samples are step-by-step put:

- in drawer-type drying stove for 8 hours with temperature $60 \pm 5^\circ\text{C}$
- in exsiccator for 16 hours, that is full of water, with air relative humidity level of 100% over it with temperature $23 \pm 5^\circ\text{C}$
- in drawer-type drying stove for 8 hours with temperature $60 \pm 5^\circ\text{C}$
- in drawer-type drying stove for 16 hours with temperature $23 \pm 5^\circ\text{C}$ with relative humidity level of $65 \pm 5\%$

All those operations compose one cycle (48 hours). Testing method includes 7 cycles using this scheme. During the testing overseeing control is taken over specimens conditions.

Then the mass loss of the main samples and the average mass loss of them (P_o , %) have to be defined according to the previous test method. As the result of the test the difference $P_o - P_k$, approximated to integral number of percents, is accepted.

Applied fire retardant passed the aging test, if on the surface of coating cracks, peeling, pimple and other destruction have not been observed.

If the following inequality has been passed:

$$P_o - P_k \leq 3 \text{ if } P_k \leq 9; \quad (9)$$

$$P_k - P_o \leq 5 \text{ if } 9 < P_k \leq 25, \quad (10)$$

Where P_o - mass loss average value of 3 main samples, %

P_k -mass loss average value of 3 control samples, %

7.4 Quality testing methods (GOST 30704-2001)

Sampling

Liquid protective reagents sampling

For quality check of preparation the single sample is taken from a bin using 1,2 m glass tube. Single "sample taken" have to be done for not less than 10% units of production. All the single samples have to be collected in one capacity, mixed with each other, the average volume of mixture is 2,25 liters. 0,5 kg of the average sample have to be obtained from the average volume.

Dispersion protective reagents sampling

For quality check of dispersion the spot samples are taken, after removing the membrane and mixing to homogeneous state. Samples are taken using a glass tube with tapered tips, diameter 10-15 mm and length 0,9-1,5 m. All the spot samples have to be collected in one capacity, mixed with each other, the average volume of mixture is 2,25 liters. 0,5 kg of average sample have to be obtained from the average volume.

Specimen (GOST 30028.3-93)

Specimens have to be made of straight- grained air-dry spruce wood with 8-15% humidity level and density from 400 to 550 g/m³ in rectangular form with cross section of 15×15mm and length along the grain 6 mm, deviation from the reference dimensions should not exceed 0,5 mm.

Protective reagent is tested with not less than 5 absorptions. Recommended absorptions are 5,10,20,40,80 kg/m³.

Testing apparatus

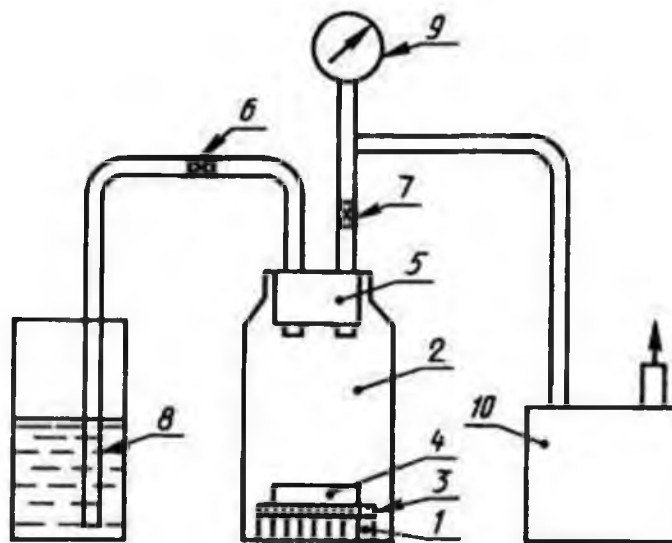

1-Wood specimens, 2 treating tubule, 3- grid, 4- anti-float up system 5- plug, 6,7- tap, 8- can with testing reagent preparation, 9- vacuum meter, 10- vacuum pump

Figure 6 Apparatus for steeping specimens

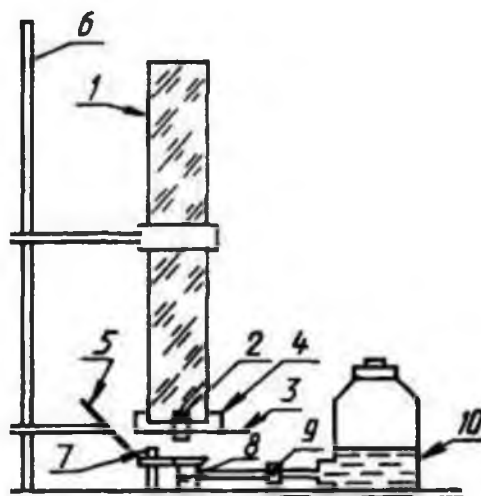

Tube made from quartz glass with inner diameter 90 mm, "wall" thickness 5mm and length 800 mm, 2 – wooden specimen, 3- needle for hanging specimen, 4- needle support, 5- mirror, 6- stand, 7- damper, 8- lighting up equipment, 9 – hose with clamp, 10- can for spirit

Figure 7 Apparatus for burning specimens

Other equipment used in testing method:

- Timing device
- desiccator with drier
- steel weighing vessel with cover, volume- 50 cm³

- awl
- Petri dishes
- grid from steel or from noncorrosive material
- weight
- spirit
- water
- Filtered paper
- Organic solvent

Test Operation

Wooden specimens before steeping are marked, air-conditioned with temperature $20 \pm 2^\circ\text{C}$ and relative humidity level $65 \pm 2\%$ till getting the equilibrium moisture content. Before steering specimens are weighed with tolerance at most 0,005 g.

At every stage every specimen has to be weighed.

Protective reagent liquid has to be prepared using “weight” or “weight-volume” method. Water or other organic substance has to be used as solvent, depending on the type of protective reagent.

Test for every specified absorption has to be performed not less than 3 times on 10 specimens.

Wood Treating capacity has to be defined for concentration calculation of protective reagent in liquid. Wooden specimens treating capacity is defined according to solvent not less than 3 times on 10 specimens.

Wooden specimens, treating capacity in one test P in kilograms on cubic meter is calculated using the following equation:

$$P = \frac{m_1 - m}{V} \cdot 10^3, \quad (11)$$

Where, m – mass of specimen before absorption, g

m_1 – mass of specimen after absorption, g

V – volume of wooden specimen, cm^3

By results the value of wooden specimen’s treating capacity in one test; the average treating capacity P_{cp} for all tests is defined using following equation:

$$P_{cp} = \frac{\sum_{i=1}^n P_i}{n}, \quad (12)$$

Where P_1, P_2, \dots, P_n - Wooden specimen's treating capacity in one test, kg/m³,
n- number of tests.

The difference between results of Wooden specimens treating capacity in one test and the average treating capacity for all tests have to be less than 10%.

Concentration of protective reagent in steeping liquid C in percent is calculated using the following equation:

$$C = \frac{Q \cdot 100}{P_{cp}}, \quad (13)$$

Where, Q- specified absorption of protective reagent.

Absorption of wooden specimens is done using "vacuum" method -

- atmospheric absolute pressure in apparatus (Figure 6) with basic vacuum not less 0,09MPa;
- duration 15±1min
- duration of soaking in protective reagent liquid with atmospheric absolute pressure is 30±1min.

Test procedure:

- Put wooden specimens (1) in treating tubule (2),
- Cover specimens by grid/grille (3)
- Put anti-float up system (4) above the grille/grid
- Bung treating tubule by plug (5)
- Lock tap (6), open/unlock tap (7)
- Switch on vacuum pump (10)
- Upon reaching the target value of vacuum, (control using vacuum meter (9))
- Endure wooden specimens in vacuum for a specified time
- Open tap (6).
- Under the influence of vacuum, testing reagent preparation inflow to treating tubule.
- Switch off vacuum pump, lock tap (7)

- Expose wooden specimens in reagent preparation for specified time.
- In the end of absorption, remove wooden specimens from treating tubule
- Dry surface of specimens using filtered paper
- Weigh specimens with tolerance less than 0,005 g.

Absorption of protective reagent Q_1 in kilograms on cubic meter is calculated using the following equation:

$$Q_1 = \frac{(m_3 - m_2) \cdot c \cdot 100}{V_1}, \quad (14)$$

Where, m_2 – mass of wooden specimen before absorption, g

m_3 -mass of wooden specimen after absorption, g

V_1 - volume of wooden specimen, cm

C – concentration of protective reagent preparation, %

The protective reagent absorption deviation of the test results should not exceed $\pm 10\%$ from the declared value.

Weighed specimens put edgeways into open Petri dishes and expose in 2-3 days with temperature 20 ± 2 °C and relative humidity level $65 \pm 2\%$

Then specimens are put in desiccator with saturated preparation of drying substance for 14 days, that provides attaining to moisture level of unabsorbed specimens- $9 \pm 2\%$

Tests have to be made in enclosure with natural draught in burning apparatus.(Figure 7)

Specimen is put in preliminary weighed vessel and weighed with tolerance not more than 0,02 g.

Test procedure (Figure 7):

- Wooden specimen is taken out from vessel
- Pined up on the awl in the middle and hanged on the cutting edge of needle (3)
- Needle is located in the middle of tube made of quartz glass (1) and lighting up equipment (8)
- Distance between tail edge and lighting up equipment is 25 mm.
- lighting up equipment is filled by methylated spirit to the level lower than top edge on 1 ± 2 mm.
- During the test the level of spirit has to be constant

- Set a fire, switch on timing device
- After 20 seconds of burning carefully, to avoid knocking down the flame from specimen (2), cover the lighting up equipment using damper (7)
- Observe the combustion of wooden specimen. Use timing device to fix duration of combustion and smoldering of specimen.

After the end of combustion unburnt rests of wooden specimen carefully, without losses, are taken from the edge of needle and put into vessel. Cooling of wooden specimen rests takes not less than 30 min. Weighing of specimen rests have to be done using vessel and with tolerance less than 0,02 g.

Test-data reduction

Mass loss of wooden specimen during the combustion (ΠM) in percent is calculated using the following equation:

$$\Pi M = \frac{m_4 - m_5}{m_4 - m_0}, \quad (15)$$

Where m_4 - mass of wooden specimen with vessel before combustion, g

m_5 – mass of wooden specimen with vessel after combustion, g

m_0 - mass of vessel, g

The average mass loss of specimens under absorption with the same specified ingesting is defined as arithmetical average of 3 tests results.

The allowed relative mass loss deviation of every specimen from the average mass loss is $\pm 10\%$.

Absorption, that provides 25% mass loss of wooden specimens during combustion, is defined using the following diagram (Figure 8).

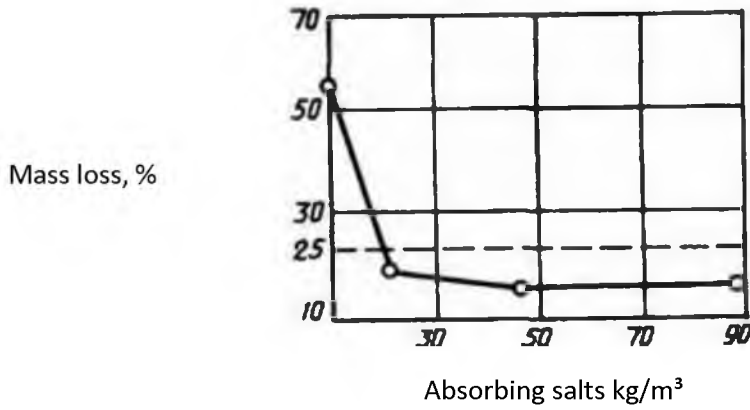

Figure 8 Mass loss on absorption diagram

Using the value of absorption above, the fire-protective class is given to tested protective reagent. (See table 1)

Table 2 Fire protective class on value of absorption

Absorption of protective reagent, That provides 25% mass loss, kg/m ³	Fire-protective class of protective reagent
Less than 30	I
More than 30, less than 50	II
50 and more	III

According to duration of wooden specimen's self-combustion, the type of protective reagent on fire-protective capability is given. (See table 3)

Table 3 Type of protective reagent on fire protective capability

Class of fire- protective capability	Duration of wooden specimens self-combustion, s, not less		Type of fire- protective on fire-protective capability
	flame	glow	
I II III	20 30 40	Not specified	Flame arrester
I II III	Not specified	30 50 70	Anti-glower
I II III	20 30 40	30 50 70	multifunctional

The example for a certificate given to protective reagent based on tests, see Appendix 1.

7.5 Common technical guidelines for all chemical products realized in Russian federation (GOST 13645)

Guidelines for allowed properties of protective reagents have to correspond the pointed out characteristics. (See table 4).

Table 4

Name of characteristic	Value Guidelines depending on protective reagent nature of action							
	biodefense	Fire-biodefense	Fire-water-defense	Bio-moisture-defense	Fire-defense	Fire-moisture-defense	Moisture-defense	Protective-decorative
solvability with T=20 °C, not more*	0,5	15	15	1	15	15	1	-
pH of water preparation**	3-12	3-12	3-12	3-12	3-12	3-12	3-12	-
Efficacy to mold fungi and ink fungi	High-efficiency	effective		High-efficiency	middle-efficiency		-	effective
Efficacy to standard stamp mold <i>Coniophora puteana</i> (liminal absorption), % on wooden mass, not more	4***	10	10	5	-	-	-	5
Corrosion aggression (corrosion rate), g/m ² per day, not more	2	4	4	2	4	4	-	-
Stability on ablation	Settle depending on functionality of protective reagent							
Absorption, that provides 25% mass loss of wooden specimens during combustion								

For impregnating compound, kg/m ³	-	40	45	-	30	35	-	-
For surface reagents, g/m ²	-	1100	1300	-	1000	1200	-	-
Breaking strength of glue joint on shear along The grain of impregnated wood (in comparison with impregnated)	Allowed breaking strength of glue joint on shear along the grain is not more than 15 %							
Tensile strength of impregnated wood (in comparison with impregnated)	Allowed tensile strength reduction value not more than 20 %							
Penetrating into wood (treating coefficient), not less	0,4	0,6	0,6	0,4	0,6	0,6	-	-
Harmful effect on human and nature	Not consist of unfixable in wood substances of I class danger according to GOST 12.1.007							
Coloring of wood	Settle depending on functionality of treated wood							
Smell	Settle depending on functionality of treated wood, but not extremely irritating and acrid odour							
Finishing works on treated wood	Settle depending on functionality of treated wood							
Water absorption of wood (in comparison with impregnated), %, not more	-	-	50	50	-	50	50	50*4
Influence on other materials and reagents In direct contact	Settle depending on functionality of treated wood							

7.6 Correspondence Conformation of the products according to the technical federal law of Russian federation

There are schemes of certifying the product:

1) for products produced in lots:

-Correspondence declaration of relator based on own evidence (scheme 1d);

-Correspondence declaration of producer (seller) based on own evidence and testing of typical specimen product in certified testing laboratory(scheme 2d);

-Manufacturer correspondence declaration based on own evidence, testing of typical specimen product in certified testing laboratory and certification of quality control applied to producing the item (scheme 3d)

-Product certification based on manufacturing conditions analysis and testing of typical specimen product in certified testing laboratory (scheme 4d)

-Product certification based on testing of typical specimen product in certified testing laboratory with the following assessor control (scheme 3c)

-Product certification based on manufacturing conditions analysis and testing of typical specimen product in certified testing laboratory with the following assessor control (scheme 4c)

-Product certification based on testing the typical specimen product in certified testing laboratory and certification of quality control with following assessor control (scheme 5c)

2) for limited batch of product

a) manufacturer declaration(seller) based on own evidence, representative samples from production lot testing in certified laboratory (scheme 6c)

b) production lot certification based on testing of representative samples from this production lot in certified laboratory (scheme 7c)

c) production units certification based on testing the production unit in certified testing laboratory (scheme 7c)

3) testing the Representative sampling specimens for correspondence attestation of products according to requirements of fire safety is defined according to Russian Federation legislation.

4) Schemes 1d and 5d are applied for product corresponding attestation according to materials and matter fire safety regulations, apart from:

- a) building materials;
- b) antislip finishing agents for rolling equipment of railway transport and metropolitan railway;
- c) fire-protective and fire-extinguishing matters.

8. Conclusion

The primary objective of this thesis has been providing information about fire tests in EU countries and in Russian Federation. The EU classification system has been shown. Two models of predicting the single burning item have been observed. The following tests have been studied: Cone Calorimeter test, Small Flame test, Single Burning Item test, Radiant Panel test, Ceramic pipe test, Aging Test, Quality test. Russian Federal law for certification of products has been inspected. Common technical guidelines for products realized in Russian Federation been shown. Results of research are given to B.T. Wood Company as first and general information about certification and obligatory fire tests. Information that is given into that report can be used for quantity estimation of materials needed for tests (Number of specimens, volume of specimens, volume of treatment and other materials needed). Usage of that information, also, can help in defining the optimal scheme in certification of products.

References

GOST 2.144

GOST 30028.4-2006

GOST 30495-2006

GOST 16712-95

GOST 28184089

Tuula Hakkarainen "Studies on fire safety assessment of construction products"

Esko Mikkola "European classes for the reaction to fire performance of wood products"

E1 THE NATIONAL BUILDING CODE OF FINLAND "Fire safety of buildings
Regulations and guidelines" 2002

Appendix 1

Example of Small flame test results report

**BS EN ISO 11925-2:
2002**

**Ignitability Of Building
Products Subjected To
Direct Impingement Of
Flame**

WF Report Number:

161320

Date:

2nd March 2007

Test Sponsor:

**NanTong Super
Composite Material
Company Limited**



0249

**Bodycote warringtonfire Test
Report No. 161320**

BS EN ISO 11925-2: 2002

**Reaction To Fire Tests - Ignitability
Of Building Products Subjected To
Direct Impingement Of Flame –
Part 2: Single-flame Source Test**

Sponsored By

**NANTONG SUPER COMPOSITE
MATERIAL COMPANY LIMITED
NO. 188 MIANJI ROAD
TANHZHA
NANTONG 226002
CHINA**

Commercial in confidence



CONTENTS	PAGE NO.
TEST DETAILS.....	4
DESCRIPTION OF TEST SPECIMENS.....	5
TEST RESULTS	7
SIGNATORIES.....	8
Table 1	9
Table 2	9



Test Details

Purpose of test	<p>To determine the performance of specimens of a product when they are subjected to the conditions of the test specified in BS EN ISO 11925-2:2002 "Reaction to Fire tests - Ignitability Of Building Products Subjected to Direct Impingement of Flame – Part 2: Single Flame Source Test".</p> <p>The test was performed in accordance with the procedure specified in BS EN ISO 11925-2:2002 Reaction to Fire Tests - Ignitability of Building Products subjected to direct impingement of flame – Part 2: Single Flame Source Test, and this report should be read in conjunction with that BS EN ISO Standard.</p>
Scope of test	BS EN ISO 11925-2 specifies a method of test for determining the ignitability of building products by direct small flame impingement under zero impressed irradiance using specimens tested in a vertical orientation.
Fire test study group/EGOLF	Certain aspects of some fire test specifications are open to different interpretations. The Fire Test Study Group and EGOLF have identified a number of such areas and have agreed Resolutions which define common agreement of interpretations between fire test laboratories which are members of the Groups. Where such Resolutions are applicable to this test they have been followed.
Instruction to test	The test was conducted on the 27 th January 2007 at the request of NanTong Super Composite Material Company Limited, the sponsor of the test.
Provision of test specimens	The specimens of grating were supplied by the sponsor of the test. Bodycote warringtonfire was not involved in any selection or sampling procedure. Bodycote warringtonfire supplied the particleboard substrate.
Conditioning of specimens	<p>The specimens were received on the 19th January 2007.</p> <p>Prior to test the specimens were stored for eight days in a standard atmosphere as defined in BS EN 13238:2001 Conditioning Procedures and General Rules for selection of substrates until constant mass was achieved.</p>
Substrate	The specimens were tested over an 18mm thick non flame retardant grade particleboard substrate.
Flame application time	The flame was applied for fifteen seconds

Description of Test Specimens

The description of the specimens given below has been prepared from information provided by the sponsor of the test. All values quoted are nominal, unless tolerances are given.

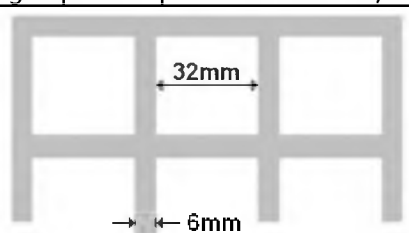
General description		A flame retardant grade, fibre reinforced resin grating	
Product reference		"SUPERFRP-IFR"	
Thickness		15mm	
Weight per unit area		12.0 kg/m ²	
Colour reference		"Grey"	
Name of manufacturer		NanTong Super Composite Material Co., Ltd.	
Diagram of grating		 <p>Note: Not to scale</p>	
Fibre reinforced resin grating	Resin	Generic type	Isophthalic polyester resin
		Product reference	"SUPERFRP-IFR"
		Name of manufacturer	See Note 1 Below
		Composition details	See Note 2 Below
		Trade name of flame retardant	See Note 1 Below
		Generic type of flame retardant	See Note 1 Below
		Amount of flame retardant (%)	See Note 2 Below
	Reinforce-ment	Generic type	Fibre glass
		Product reference	"100% Fibergalss"
		Name of manufacturer	See Note 1 Below
		Composition details	100% no- alkaline fiberglass
		Configuration of reinforcement	Randomly dispersed throughout the product
		Flame retardant details	See Note 1 Below
		Percentage reinforcement (by weight)	See Note 1 Below
Resin to reinforcement ratio (by weight)	See Note 1 Below		
Substrate	Product reference	Particle Board	
	Overall thickness	18mm	
	Density	680±50 Kg/m ³	
	Flame retardant details	No Flame retardant present	
Brief description of manufacturing process of fibre reinforce resin grating		Moulded product. The sponsor did not provide any further information relating to the manufacturing process	

Note 1 – The sponsor was unwilling to provide this information

Note 2 – The sponsor of the test has provided this information but at the specific request of the sponsor, these details have been omitted from the report and are instead held on the confidential file relating to this investigation

The description of the specimens given above is not as complete as would normally be the case for descriptions included in Bodycote warringtonfire test reports, and the description does not fully comply with the requirements of the standard. In all other respects, however, the tests were conducted fully in accordance with the requirements of the standard and the test results are valid.

Commercial in confidence

Test Results

Number of specimens tested

Six specimens were tested, each of which were subjected to surface exposure to flame with one of two identical faces exposed.

Six specimens were tested, each of which were subjected to edge exposure to flame with one of two identical faces exposed.

Applicability of test results

The test results relate to the behaviour of the test specimens of a product under the particular conditions of the test, they are not intended to be the sole criterion for assessing the potential fire hazard of the product in use.

The test results relate only to the specimens of the product in the form in which they were tested. Small differences in the composition or thickness of the product may significantly affect the performance during the test and may therefore invalidate the test results. Care should be taken to ensure that any product which is supplied or used is fully represented by the specimens which were tested.

The test results for the individual specimens, together with observations made during the test and comments on any difficulties encountered during the test are given in Tables 1 and 2.

On each set of six specimens which were tested, the flame tip did not reach a distance of 150mm before the end of the test.

Validity

The specification and interpretation of fire test methods are the subject of ongoing development and refinement. Changes in associated legislation may also occur. For these reasons it is recommended that the relevance of test reports over five years old should be considered by the user. The laboratory that issued the report will be able to offer, on behalf of the legal owner, a review of the procedures adopted for a particular test to ensure that they are consistent with current practices, and if required may endorse the test report.

This report may only be reproduced in full. Extracts or abridgements shall not be published without permission of **Bodycote warringtonfire**.

Signatories

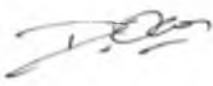
Responsible Officer D. J. Owen *

Approved I. Moore * Laboratory Supervisor

Authorised C. Dean * Operations Manager

* For and on behalf of **Bodycote warringtonfire**.

Report Issued: 2nd March 2007

This version of the report has been produced from a .pdf format electronic file that has been provided by **Bodycote warringtonfire** to the sponsor of the report and must only be reproduced in full. Extracts or abridgements of reports must not be published without permission of **Bodycote warringtonfire**. The original signed paper version of this report, which includes signatures in blue ink, is the sole authentic version. Only original paper versions of this report bear authentic signatures of the responsible **Bodycote warringtonfire** staff.

Table 1**Test Flame Application Position - Surface Of One Of Two Identical Faces**

Specimen No.	Ignition Yes/No	Time from start of test for flame tip to reach 150mm (seconds)	Extent of Flame Spread (mm)	Flaming Debris	Glowing	Extent of Damaged Area (mm)	
						Height	Width
1	YES	DID NOT REACH	20	NONE	NONE	10	5
2	YES	DID NOT REACH	20	NONE	NONE	10	5
3	YES	DID NOT REACH	20	NONE	NONE	10	5
4	YES	DID NOT REACH	20	NONE	NONE	10	5
5	YES	DID NOT REACH	20	NONE	NONE	10	5
6	YES	DID NOT REACH	20	NONE	NONE	10	5

Table 2**Test Flame Application Position - Edge Of One Of Two Identical Faces**

Specimen No.	Ignition Yes/No	Time from start of test for flame tip to reach 150mm (seconds)	Extent of Flame Spread (mm)	Flaming Debris	Glowing	Extent of Damaged Area (mm)	
						Height	Width
1	YES	DID NOT REACH	20	NONE	NONE	10	5
2	YES	DID NOT REACH	20	NONE	NONE	10	5
3	YES	DID NOT REACH	20	NONE	NONE	10	5
4	YES	DID NOT REACH	20	NONE	NONE	10	5
5	YES	DID NOT REACH	20	NONE	NONE	10	5
6	YES	DID NOT REACH	20	NONE	NONE	10	5

Appendix 2

Example of Radiant panel test report

**BS EN ISO 9239-1:
2002**

**Fire Tests For
Determination Of The
Burning Behaviour of
Floorings**

WF Report Number:

161319

Date:

2nd March 2007

Test Sponsor:

**NanTong Composite Super
Material
Company Limited**

**Bodycote warringtonfire Test
Report No. 161319**

**BS EN ISO 9239-1: 2002 – Reaction
To Fire Tests For Floorings – Part 1:
Determination Of The Burning
Behaviour
Using A Radiant Heat Source**

Sponsored By

**NANTONG SUPER COMPOSITE
MATERIAL COMPANY LIMITED
NO. 188 MIANJI ROAD
TANHZHA
NANTONG 226002
CHINA**

Commercial in confidence



CONTENTS	PAGE NO.
TEST DETAILS.....	4
DESCRIPTION OF TEST SPECIMENS	6
TEST RESULTS	8
SIGNATORIES.....	9
 Table 1	10

Test Details

Purpose of test	<p>To determine the performance of specimens of a product when they are subjected to the conditions of the test procedure defined in the document BS EN ISO 9239-1:2002 - Reaction To Fire Tests For Floorings – Part 1: Determination Of The Burning Behaviour Using A Radiant Heat Source.</p> <p>The test was performed in accordance with the procedure defined in BS EN ISO 9239-1:2002 and this report should be read in conjunction with that Standard.</p>
Scope of test	<p>BS EN ISO 9239-1:2002 describes a European test procedure for assessing the burning behaviour, spread of flame and smoke development of horizontally mounted floorcovering systems exposed to a radiant heat gradient in a test chamber, when ignited with a pilot flame.</p> <p>The measurements provide a basis for estimating one aspect of fire exposure behaviour of floor covering systems. The imposed radiant flux simulates the thermal radiation levels likely to impinge on the floors of a building whose upper surfaces are heated by flames or hot gases or both, from a fire in an adjacent room or compartment.</p> <p>This method is applicable to all types of floorcoverings such as textile carpet, cork, wood, rubber and plastic coverings as well as coatings. Results obtained by this method reflect the performance of the total floor covering system as tested. Modifications of the backing, bonding to a substrate, underlay, or other changes to the system may affect the test results.</p> <p>The test is intended for regulatory purposes, specification acceptance, design purposes, classification, or development and research.</p>
Fire test study group/EGOLF	<p>Certain aspects of some fire test specifications are open to different interpretations. The Fire Test Study Group and EGOLF have identified a number of such areas and have agreed Resolutions which define common agreement of interpretations between fire test laboratories which are members of the Groups. Where such Resolutions are applicable to this test they have been followed.</p>
Instruction to test	<p>The test was conducted on the 27th January 2007 at the request of NanTong Super Composite Material Company Limited, the sponsor of the test.</p>
Provision of test specimens	<p>The specimens of grating were supplied by the sponsor of the test. Bodycote warringtonfire was not involved in any selection or sampling procedure. Bodycote warringtonfire supplied the particleboard substrate.</p>

Conditioning of specimens	<p>The specimens were received on the 19th January 2007</p> <p>Prior to test the specimens were conditioned to constant mass at a temperature of $23 \pm 2^{\circ}\text{C}$ and a relative humidity of $50 \pm 5\%$.</p>
Number of specimens tested	<p>A total of three specimens were tested.</p>
Exposed face	<p>One of two identical faces of the specimens was exposed to the radiant heat of the test when the specimens were mounted in the test position.</p>
Substrate	<p>The specimens were tested with an 18mm thick non flame retardant grade particleboard substrate present.</p>

Description of Test Specimens

The description of the specimens given below has been prepared from information provided by the sponsor of the test. All values quoted are nominal, unless tolerances are given.

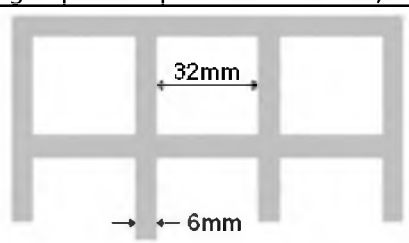
General description		A flame retardant grade, fibre reinforced resin grating	
Product reference		"SUPERFRP-IFR"	
Thickness		15mm	
Weight per unit area		12.0 kg/m ²	
Colour reference		"Grey"	
Name of manufacturer		NanTong Super Composite Material Co., Ltd.	
Diagram of grating		 <p style="text-align: center;">Note: Not to scale</p>	
Fibre reinforced resin grating	Resin	Generic type	Isophthalic polyester resin
		Product reference	"SUPERFRP-IFR"
		Name of manufacturer	See Note 1 Below
		Composition details	See Note 2 Below
		Trade name of flame retardant	See Note 1 Below
		Generic type of flame retardant	See Note 1 Below
		Amount of flame retardant (%)	See Note 2 Below
	Reinforce-ment	Generic type	Fibre glass
		Product reference	"100% Fibergalss"
		Name of manufacturer	See Note 1 Below
		Composition details	100% no- alkaline fiberglass
		Configuration of reinforcement	Randomly dispersed throughout the product
		Flame retardant details	See Note 1 Below
	Percentage reinforcement (by weight)		See Note 1 Below
Resin to reinforcement ratio (by weight)		See Note 1 Below	
Substrate	Product reference	Particle Board	
	Overall thickness	18mm	
	Density	680±50 Kg/m ³	
	Flame retardant details	No Flame retardant present	
Brief description of manufacturing process of fibre reinforce resin grating		Moulded product. The sponsor did not provide any further information relating to the manufacturing process	

Note 1 – The sponsor was unwilling to provide this information

Note 2 – The sponsor of the test has provided this information but at the specific request of the sponsor, these details have been omitted from the report and are instead held on the confidential file relating to this investigation

The description of the specimens given above is not as complete as would normally be the case for descriptions included in Bodycote warringtonfire test reports, and the description does not fully comply with the requirements of the standard. In all other respects, however, the tests were conducted fully in accordance with the requirements of the standard and the test results are valid.

Commercial in confidence

Test Results

The test results relate to the behaviour of the test specimens of a product under the particular conditions of test; they are not intended to be the sole criterion for assessing the potential fire hazard of the product in use.

The test results relate only to the specimens of the product in the form in which they were tested. Small differences in the composition or thickness of the product may significantly affect the performance during the test and may therefore invalidate the test results. Care should be taken to ensure that any product which is supplied or used is fully represented by the specimens which were tested.

The distance between the flame front and the zero point at 10 minute intervals together with the observations recorded during the tests in respect of each specimen tested, are given in Table 1.

In accordance with the procedure defined in BS EN ISO 9239-1:2002, the following results were obtained:

Average maximum flame front distance	=	15 cm
Average critical radiant flux	=	10.8 kW/m ²
Average smoke development	=	274.0 % min
Average maximum light attenuation	=	23.7 %

Validity

The specification and interpretation of fire test methods are the subject of ongoing development and refinement. Changes in associated legislation may also occur. For these reasons it is recommended that the relevance of test reports over five years old should be considered by the user. The laboratory that issued the report will be able to offer, on behalf of the legal owner, a review of the procedures adopted for a particular test to ensure that they are consistent with current practices, and if required may endorse the test report.

This report may only be reproduced in full. Extracts or abridgements shall not be published without permission of **Bodycote warringtonfire**.

Signatories

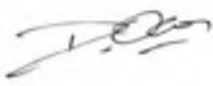
Responsible Officer D. J. Owen *

Approved I. Moore * Senior Laboratory Supervisor

Authorised C. Dean * Operations Manager

* For and on behalf of **Bodycote warringtonfire**.

Report Issued: 2 nd March 2007

This version of the report has been produced from a .pdf format electronic file that has been provided by **Bodycote warringtonfire** to the sponsor of the report and must only be reproduced in full. Extracts or abridgements of reports must not be published without permission of **Bodycote warringtonfire**. The original signed paper version of this report, which includes signatures in blue ink, is the sole authentic version. Only original paper versions of this report bear authentic signatures of the responsible **Bodycote warringtonfire** staff.

Table 1

SPECIMEN NO.	1	2	3
DISTANCE (cm)	TIME TO TRAVEL TO INDICATED DISTANCE (minutes, seconds)		
5	6:53	7:19	6:09
10	15:38	15:21	17:40
15	26:02	24:59	27:52
20			
25			
30			
35			
40			
45			
50			
55			
60			
65			
70			
75			
80			
85			
90			
95			
100			
Max. flame front distance (cm)	15	15	15
Critical radiant flux (kW/m ²)	10.8	10.8	10.8
Smoke Development (%.min)	270.3	284.6	267.3
Max. light attenuation (%)	17.4	25.8	28.0

Specimen Number	1	2	3
Flame front distance at 10 min (cm)	7	7	7
Flame front distance at 20 min (cm)	12	12	12
Flame front distance at 30 min (cm)	15	15	15
Radiant flux at 10 minutes, Rf ₁₀ (kW/m ²)	≥11.2	≥11.2	≥11.2
Radiant flux at 20 minutes, Rf ₂₀ (kW/m ²)	≥11.2	≥11.2	≥11.2
Radiant flux at 30 minutes, Rf ₃₀ (kW/m ²)	10.8	10.8	10.8

Observations Of The Burning Characteristics Of The Specimens During The Testing Exposure

None.

Appendix 3

Example of Russian Material Safety Data Sheet

Material Safety Data Sheet

Ethyl Alcohol, 70%

ACC# 91791

Section 1 - Chemical Product and Company Identification

MSDS Name: Ethyl Alcohol, 70%

Catalog Numbers: S75119, S75120, S556CA4

Synonyms: Ethyl Alcohol; Ethyl Hydrate; Ethyl Hydroxide; Fermentation Alcohol; Grain Alcohol; Methylcarbinol; Molasses Alcohol; Spirits of Wine.

Company Identification:

Fisher Scientific
1 Reagent Lane
Fair Lawn, NJ 07410

For information, call: 201-796-7100

Emergency Number: 201-796-7100

For CHEMTREC assistance, call: 800-424-9300

For International CHEMTREC assistance, call: 703-527-3887

Section 2 - Composition, Information on Ingredients

CAS#	Chemical Name	Percent	EINECS/ELINCS
64-17-5	Ethyl alcohol	70	200-578-6
7732-18-5	Water	30	231-791-2

Hazard Symbols: F

Risk Phrases: 11

Section 3 - Hazards Identification

EMERGENCY OVERVIEW

Appearance: colorless clear liquid. Flash Point: 16.6 deg C. **Flammable liquid and vapor.** May cause central nervous system depression. Causes severe eye irritation. Causes respiratory tract irritation. Causes moderate skin irritation. This substance has caused adverse reproductive and fetal effects in humans. **Warning!** May cause liver, kidney and heart damage.

Target Organs: Kidneys, heart, central nervous system, liver.

Potential Health Effects

Eye: Causes severe eye irritation. May cause painful sensitization to light. May cause chemical conjunctivitis and corneal damage.

Skin: Causes moderate skin irritation. May cause cyanosis of the extremities.

Ingestion: May cause gastrointestinal irritation with nausea, vomiting and diarrhea. May cause systemic toxicity with acidosis. May cause central nervous system depression, characterized by excitement, followed by headache, dizziness, drowsiness, and nausea. Advanced stages may cause collapse, unconsciousness, coma and possible death due to respiratory failure.

Inhalation: Inhalation of high concentrations may cause central nervous system effects characterized by nausea, headache, dizziness, unconsciousness and coma. Causes respiratory tract irritation. May cause narcotic effects in high concentration. Vapors may cause dizziness or suffocation.

Chronic: May cause reproductive and fetal effects. Laboratory experiments have resulted in mutagenic effects. Animal studies have reported the development of tumors. Prolonged exposure may cause liver, kidney, and heart damage.

Section 4 - First Aid Measures

Eyes: Immediately flush eyes with plenty of water for at least 15 minutes, occasionally lifting the upper and lower eyelids. Get medical aid. Gently lift eyelids and flush continuously with water.

Skin: Get medical aid. Flush skin with plenty of water for at least 15 minutes while removing contaminated clothing and shoes. Wash clothing before reuse. Flush skin with plenty of soap and water.

Ingestion: Do NOT induce vomiting. If victim is conscious and alert, give 2-4 cupfuls of milk or water. Never give anything by mouth to an unconscious person. Get medical aid.

Inhalation: Remove from exposure and move to fresh air immediately. If not breathing, give artificial respiration. If

breathing is difficult, give oxygen. Get medical aid. Do NOT use mouth-to-mouth resuscitation.

Notes to Physician: Treat symptomatically and supportively. Persons with skin or eye disorders or liver, kidney, chronic respiratory diseases, or central and peripheral nervous system diseases may be at increased risk from exposure to this substance.

Antidote: Replace fluid and electrolytes.

Section 5 - Fire Fighting Measures

General Information: Containers can build up pressure if exposed to heat and/or fire. As in any fire, wear a self-contained breathing apparatus in pressure-demand, MSHA/NIOSH (approved or equivalent), and full protective gear. Vapors may form an explosive mixture with air. Vapors can travel to a source of ignition and flash back. Will burn if involved in a fire. Flammable Liquid. Can release vapors that form explosive mixtures at temperatures above the flashpoint. Use water spray to keep fire-exposed containers cool. Containers may explode in the heat of a fire.

Extinguishing Media: For small fires, use dry chemical, carbon dioxide, water spray or alcohol-resistant foam. For large fires, use water spray, fog, or alcohol-resistant foam. Use water spray to cool fire-exposed containers. Water may be ineffective. Do NOT use straight streams of water.

Flash Point: 16.6 deg C (61.88 deg F)

Autoignition Temperature: 363 deg C (685.40 deg F)

Explosion Limits, Lower: 3.3 vol %

Upper: 19.0 vol %

NFPA Rating: (estimated) Health: 2; Flammability: 3; Instability: 0

Section 6 - Accidental Release Measures

General Information: Use proper personal protective equipment as indicated in Section 8.

Spills/Leaks: Absorb spill with inert material (e.g. vermiculite, sand or earth), then place in suitable container. Remove all sources of ignition. Use a spark-proof tool. Provide ventilation. A vapor suppressing foam may be used to reduce vapors.

Section 7 - Handling and Storage

Handling: Wash thoroughly after handling. Use only in a well-ventilated area. Ground and bond containers when transferring material. Use spark-proof tools and explosion proof equipment. Avoid contact with eyes, skin, and clothing. Empty containers retain product residue, (liquid and/or vapor), and can be dangerous. Keep container tightly closed. Avoid contact with heat, sparks and flame. Avoid ingestion and inhalation. Do not pressurize, cut, weld, braze, solder, drill, grind, or expose empty containers to heat, sparks or open flames.

Storage: Keep away from heat, sparks, and flame. Keep away from sources of ignition. Store in a tightly closed container. Keep from contact with oxidizing materials. Store in a cool, dry, well-ventilated area away from incompatible substances. Flammables-area. Do not store near perchlorates, peroxides, chromic acid or nitric acid.

Section 8 - Exposure Controls, Personal Protection

Engineering Controls: Use explosion-proof ventilation equipment. Facilities storing or utilizing this material should be equipped with an eyewash facility and a safety shower. Use adequate general or local exhaust ventilation to keep airborne concentrations below the permissible exposure limits.

Exposure Limits

Chemical Name	ACGIH	NIOSH	OSHA - Final PELs
Ethyl alcohol	1000 ppm TWA	1000 ppm TWA; 1900 mg/m ³ TWA 3300 ppm IDLH	1000 ppm TWA; 1900 mg/m ³ TWA
Water	none listed	none listed	none listed

OSHA Vacated PELs: Ethyl alcohol: 1000 ppm TWA; 1900 mg/m³ TWA Water: No OSHA Vacated PELs are listed for this chemical.

Personal Protective Equipment

Eyes: Wear appropriate protective eyeglasses or chemical safety goggles as described by OSHA's eye and face protection regulations in 29 CFR 1910.133 or European Standard EN166.

Skin: Wear appropriate protective gloves to prevent skin exposure.

Clothing: Wear appropriate protective clothing to prevent skin exposure.

Respirators: A respiratory protection program that meets OSHA's 29 CFR 1910.134 and ANSI Z88.2 requirements or European Standard EN 149 must be followed whenever workplace conditions warrant a respirator's use.

Section 9 - Physical and Chemical Properties

Section 9 - Physical and Chemical Properties

Physical State: Clear liquid
Appearance: colorless
Odor: Mild, rather pleasant, like wine or whis
pH: Not available.
Vapor Pressure: 59.3 mm Hg @ 20 deg C
Vapor Density: 1.59
Evaporation Rate: Not available.
Viscosity: 1.200 cP @ 20 deg C
Boiling Point: 78 deg C
Freezing/Melting Point: -114.1 deg C
Decomposition Temperature: Not available.
Solubility: Miscible.
Specific Gravity/Density: 0.790 @ 20°C
Molecular Formula: C₂H₅OH
Molecular Weight: 46.0414

Section 10 - Stability and Reactivity

Chemical Stability: Stable under normal temperatures and pressures.
Conditions to Avoid: Incompatible materials, ignition sources, excess heat, oxidizers.
Incompatibilities with Other Materials: Strong oxidizing agents, acids, alkali metals, ammonia, hydrazine, peroxides, sodium, acid anhydrides, calcium hypochlorite, chromyl chloride, nitrosyl perchlorate, bromine pentafluoride, perchloric acid, silver nitrate, mercuric nitrate, potassium-tert-butoxide, magnesium perchlorate, acid chlorides, platinum, uranium hexafluoride, silver oxide, iodine heptafluoride, acetyl bromide, disulfuryl difluoride, tetrachlorosilane + water, acetyl chloride, permanganic acid, ruthenium (VIII) oxide, uranyl perchlorate, potassium dioxide.
Hazardous Decomposition Products: Carbon monoxide, irritating and toxic fumes and gases, carbon dioxide.
Hazardous Polymerization: Will not occur.

Section 11 - Toxicological Information

RTECS#:

CAS# 64-17-5: KQ6300000

CAS# 7732-18-5: ZC0110000

LD50/LC50:

CAS# 64-17-5:

Draize test, rabbit, eye: 500 mg Severe;
Draize test, rabbit, eye: 500 mg/24H Mild;
Draize test, rabbit, skin: 20 mg/24H Moderate;
Inhalation, mouse: LC50 = 39 gm/m³/4H;
Inhalation, rat: LC50 = 20000 ppm/10H;
Oral, mouse: LD50 = 3450 mg/kg;
Oral, rabbit: LD50 = 6300 mg/kg;
Oral, rat: LD50 = 9000 mg/kg;
Oral, rat: LD50 = 7060 mg/kg;

CAS# 7732-18-5:

Oral, rat: LD50 = >90 mL/kg;

Carcinogenicity:

CAS# 64-17-5:

ACGIH: A4 - Not Classifiable as a Human Carcinogen **CAS# 7732-18-5:** Not listed by ACGIH, IARC, NIOSH, NTP, or OSHA.

Epidemiology: Ethanol has been shown to produce fetotoxicity in the embryo or fetus of laboratory animals. Prenatal exposure to ethanol is associated with a distinct pattern of congenital malformations that have collectively been termed the "fetal alcohol syndrome".

Teratogenicity: Oral, Human - woman: TDLo = 41 gm/kg (female 41 week(s) after conception) Effects on Newborn - Apgar score (human only) and Effects on Newborn - other neonatal measures or effects and Effects on Newborn - drug dependence.

Reproductive Effects: Intrauterine, Human - woman: TDLo = 200 mg/kg (female 5 day(s) pre-mating) Fertility - female fertility index (e.g. # females pregnant per # sperm positive females; # females pregnant per # females mated).

Neurotoxicity: No information available.

Mutagenicity: DNA Inhibition: Human, Lymphocyte = 220 mmol/L.; Cytogenetic Analysis: Human, Lymphocyte = 1160

gm/L.; Cytogenetic Analysis: Human, Fibroblast = 12000 ppm.; Cytogenetic Analysis: Human, Leukocyte = 1 pph/72H (Continuous).; Sister Chromatid Exchange: Human, Lymphocyte = 500 ppm/72H (Continuous).

Other Studies: Standard Draize Test(Skin, rabbit) = 20 mg/24H (Moderate) S tandard Draize Test: Administration into the eye (rabbit) = 500 mg (Severe).

Section 12 - Ecological Information

Ecotoxicity: Fish: Rainbow trout: LC50 = 12900-15300 mg/L; 96 Hr; Flow-through @ 24-24.3°C Rainbow trout: LC50 = 11200 mg/L; 24 Hr; Fingerling (Unspecified) ria: Phytobacterium phosphoreum: EC50 = 34900 mg/L; 5-30 min; Microtox test When spilled on land it is apt to volatilize, biodegrade, and leach into the ground water, but no data on the rates of these processes could be found. Its fate in ground water is unknown. When released into water it will volatilize and probably biodegrade. It would not be expected to adsorb to sediment or bioconcentrate in fish.

Environmental: When released to the atmosphere it will photodegrade in hours (polluted urban atmosphere) to an estimated range of 4 to 6 days in less polluted areas. Rainout should be significant.

Physical: No information available.

Other: No information available.

Section 13 - Disposal Considerations

Chemical waste generators must determine whether a discarded chemical is classified as a hazardous waste. US EPA guidelines for the classification determination are listed in 40 CFR Parts 261.3. Additionally, waste generators must consult state and local hazardous waste regulations to ensure complete and accurate classification.

RCRA P-Series: None listed.

RCRA U-Series: None listed.

Section 14 - Transport Information

	US DOT	IATA	RID/ADR	IMO	Canada TDG
Shipping Name:	ETHANOL				No information available.
Hazard Class:	3				
UN Number:	UN1170				
Packing Group:	II				

Section 15 - Regulatory Information

US FEDERAL

TSCA

CAS# 64-17-5 is listed on the TSCA inventory.

CAS# 7732-18-5 is listed on the TSCA inventory.

Health & Safety Reporting List

None of the chemicals are on the Health & Safety Reporting List.

Chemical Test Rules

None of the chemicals in this product are under a Chemical Test Rule.

Section 12b

None of the chemicals are listed under TSCA Section 12b.

TSCA Significant New Use Rule

None of the chemicals in this material have a SNUR under TSCA.

SARA

CERCLA Hazardous Substances and corresponding RQs

None of the chemicals in this material have an RQ.

SARA Section 302 Extremely Hazardous Substances

None of the chemicals in this product have a TPQ.

SARA Codes

CAS # 64-17-5: acute, chronic, flammable.

Section 313

No chemicals are reportable under Section 313.

Clean Air Act:

This material does not contain any hazardous air pollutants. This material does not contain any Class 1 Ozone depleters.

This material does not contain any Class 2 Ozone depleters.

Clean Water Act:

Clean Water Act:

None of the chemicals in this product are listed as Hazardous Substances under the CWA. None of the chemicals in this product are listed as Priority Pollutants under the CWA. None of the chemicals in this product are listed as Toxic Pollutants under the CWA.

OSHA:

None of the chemicals in this product are considered highly hazardous by OSHA.

STATE

CAS# 64-17-5 can be found on the following state right to know lists: California, New Jersey, Pennsylvania, Minnesota, Massachusetts.

CAS# 7732-18-5 is not present on state lists from CA, PA, MN, MA, FL, or NJ.

WARNING: This product contains Ethyl alcohol, a chemical known to the state of California to cause birth defects or other reproductive harm. California No Significant Risk Level: None of the chemicals in this product are listed.

European/International Regulations**European Labeling in Accordance with EC Directives****Hazard Symbols:**

F

Risk Phrases:

R 11 Highly flammable.

Safety Phrases:

S 16 Keep away from sources of ignition - No smoking.

S 33 Take precautionary measures against static discharges.

S 7 Keep container tightly closed.

S 9 Keep container in a well-ventilated place.

WGK (Water Danger/Protection)

CAS# 64-17-5: 0

CAS# 7732-18-5: No information available.

Canada - DSL/NDSL

CAS# 64-17-5 is listed on Canada's DSL List.

CAS# 7732-18-5 is listed on Canada's DSL List.

Canada - WHMIS

This product has a WHMIS classification of B2, D2A, D2B.

Canadian Ingredient Disclosure List

CAS# 64-17-5 is listed on the Canadian Ingredient Disclosure List.

Exposure Limits

CAS# 64-17-5: OEL-AUSTRALIA:TWA 1000 ppm (1900 mg/m³) OEL-BELGIUM:TWA 1000 ppm (1880 mg/m³) OEL-CZECHOSLOVAKIA:TWA 1000 mg/m³;STEL 5000 mg/m³ OEL-DENMARK:TWA 1000 ppm (1900 mg/m³) OEL-FINLAND:TWA 1000 ppm (1900 mg/m³);STEL 1250 ppm (2400 mg/m³) OEL-FRANCE:TWA 1000 ppm (1900 mg/m³);STEL 5000 pp OEL-GERMANY:TWA 1000 ppm (1900 mg/m³) OEL-HUNGARY:TWA 1000 mg/m³;STEL 3000 mg/m³ OEL-THE NETHERLANDS:TWA 1000 ppm (1900 mg/m³) OEL-THE PHILIPPINES:TWA 1000 ppm (1900 mg/m³) OEL-POLAND:TWA 1000 mg/m³ OEL-RUSSIA:STEL 1000 mg/m³ OEL-SWEDEN:TWA 1000 ppm (1900 mg/m³) OEL-SWITZERLAND:TWA 1000 ppm (1900 mg/m³) OEL-THAILAND:TWA 1000 ppm (1900 mg/m³) OEL-TURKEY:TWA 1000 ppm (1900 mg/m³) OEL-UNITED KINGDOM:TWA 1000 ppm (1900 mg/m³) JAN9 OEL IN BULGARIA, COLOMBIA, JORDAN, KOREA check ACGIH TLV OEL IN NEW ZEALAND, SINGAPORE, VIETNAM check ACGI TLV

Section 16 - Additional Information

MSDS Creation Date: 4/17/2001

Revision #1 Date: 4/17/2001

The information above is believed to be accurate and represents the best information currently available to us. However, we make no warranty of merchantability or any other warranty, express or implied, with respect to such information, and we assume no liability resulting from its use. Users should make their own investigations to determine the suitability of the information for their particular purposes. In no event shall Fisher be liable for any claims, losses, or damages of any third party or for lost profits or any special, indirect, incidental, consequential or exemplary damages, howsoever arising, even if Fisher has been advised of the possibility of such damages.