

# Info package of wind energy for Finnish-Russian project BLESK

Tuomo Pimiä (ed.)



# INFO PACKAGE OF WIND ENERGY

Authors

Tuomo Pimiä (ed.)

Biktuganov Rinat

Gerlitc Iuliia

Häkkinen Jouni-Juhani

Kakko Markku

Martikainen Jukka

Matikkala Jenna

Mäkelä Merja

Tuliniemi Erja

Töyrylä Niko

Foreword by

Kai Mykkänen

Confederation of Finnish Industries (EK)

Kotka, Finland 2014

Publications of Kymenlaakso University of Applied Sciences.

Series B Research and Reports. No: 113

Copyright: Kymenlaakso University of Applied Sciences

Publisher: Kymenlaakso University of Applied Sciences

Printing press: Tammerprint Oy, Tampere 2014

ISBN (PB.): 978-952-306-029-6

ISBN (PDF): 978-952-306-030-2

ISSN: 1239-9094

ISSN: (e-version) 1797-5972

# FOREWORD

It would be much cheaper for us all to invest sufficiently in preventing global warming than suffer the risks of accelerating the growth of greenhouse emissions. Wind energy is one of the most promising and most effectively growing substitutes to fossil fuels. It cannot solve the problem alone, but it could certainly be a crucial part of the solution worldwide.

Several areas in Europe, especially Germany and Denmark, have been pioneers of wind power. They have already been building wind power infrastructure for about 20 years at an accelerating pace. Finland has actually been the last of the Nordic countries to take part in the wind power revolution. Here wind power expansion started effectively from scratch less than five years ago. Since then, national capacity has grown tenfold reaching about 300 MW last year. Slowness prevented the Finns from taking leading positions in many segments of the wind power industry, since our companies did not have a home market to push growth early enough before the market matured. On the other hand, the positive side is that now we have much more advanced equipment than that in Denmark or Germany – the newest windmills are several times larger and more effective than those built in the last decade.

What really opened Finnish market expansion was the implementation of the feed-in tariff in 2011. Since then, the expansion has accelerated very quickly. This new phenomenon greatly surprised most of the public administration responsible for processing the permits and land use plans needed to build a wind farm and connect it to the national electricity grid. We have suffered serious bottlenecks at several steps of the permit processes.

In 2013, I chaired a government working committee to simplify the permit process for wind farms. We identified 15 potential solutions for different parts of the permit process and managed to agree on solving seven of them. I hope that this attitude is developing so that the remaining eight will also be effectively solved in the near future.

Successful wind farm investment also depends very much on investors. This handbook seems to be a very useful tool to help people consider whether an investment will really break even, whether it should be permitted, what things should be done and the different steps of the process.

In Russia land use legislation and the structure of regional administration is very different. However, physical challenges are mostly the same. I am sure the Finnish administration is ready to consult

the Russian one in developing effective processes and resolving bottlenecks in our way of doing things as well. On the other hand, Russian investors are also most warmly welcome to use the opportunity of investing in the emerging Finnish wind energy market. Our 2,500 MW cap on capacity, which was granted to benefit from the 12-year feed-in tariff might be fulfilled within the next 3-5 years, so you should start the project now!

To get started, we recommend contacting the joint forces of Business Team for Russia (BTR). BTR is an umbrella coordinating the actions of three leading Finnish-Russian business structures: the Finnish-Russian Chamber of Commerce ([www.svkk.fi](http://www.svkk.fi)), the East Office of Finnish Industries ([www.eastoffice.fi](http://www.eastoffice.fi)) and the Confederation of Finnish Industries ([www.ek.fi](http://www.ek.fi)). We are always ready to help Finns to get started in Russia and vice versa.

Kai Mykkänen  
Confederation of Finnish Industries (EK)

# Table of Contents

<b>I</b>	<b>INTRODUCTION</b>	8
<b>2</b>	<b>WIND ENERGY RESOURCES</b>	9
2.1	Wind atlas	11
2.2	Measurement of wind conditions	12
2.3	Literature references	14
<b>3</b>	<b>WIND TURBINE TECHNOLOGY</b>	15
3.1	Wind turbines and their constructions	15
3.2	Drivetrain concepts	18
3.2.1	Gearboxes	21
3.2.2	Generators	22
3.3	Grid connection	25
3.3.1	Devices used for grid connections	25
3.3.2	Grid protection	27
3.3.3	Voltage control	27
3.3.4	Power output behavior	29
3.3.5	Power quality and grid connection rules	31
3.4	Control systems of wind turbines	33
3.4.1	Operation states of wind turbines	35
3.4.2	Measurement technology	36
3.4.3	Control concepts of wind turbines	37
3.4.4	Yaw control	39
3.4.5	Pitch control	40

3.4.6	Control system hardware	42
3.5	Literature references	43
<b>4</b>	<b>MAINTENANCE OF WIND TURBINES</b>	<b>45</b>
4.1	Basic concepts of maintenance	46
4.2	Operation and maintenance costs	49
4.3	Maintenance items of wind turbines	49
4.3.1	Electrical systems	50
4.3.2	Hydraulic systems	50
4.3.3	Blades	51
4.3.4	Control systems	51
4.4	Failures	51
4.5	Preventive maintenance and condition monitoring	54
4.6	Corrective maintenance on site and in remote operation	56
4.7	Literature references	58
<b>5</b>	<b>LAWS AND REGULATIONS</b>	<b>60</b>
5.1	Wind power in Finland	60
5.1.1	Feed-in tariff	61
5.2	Wind energy regulation	61
5.2.1	Placement and zoning of wind power plants	62
5.2.2	Building permits	63
5.2.3	Wind power subsidies	64
5.3	Literature references	65
<b>6</b>	<b>PRE-FEASIBILITY STUDY</b>	<b>66</b>
6.1	Site investigation and evaluation of environmental impact	67
6.1.1	Investment costs	68
6.1.2	Operating and maintenance costs	70

6.1.3	Production costs	71
6.2	Engineering calculations and Weibull distribution	72
6.3	Example of a wind turbine project	77
6.4	Literature references	82
<b>7</b>	<b>WIND TURBINE PROJECTS</b>	<b>84</b>
7.1	Project phases	85
7.2	Case Mäkelänkangas	86
7.2.1	Unloading of the parts and assembly	87
7.2.2	Experiences of Mäkelänkangas in operation	88
7.3	Wind turbine projects in Kymenlaakso	88
7.4	Literature references	90
<b>8</b>	<b>SUMMARY</b>	<b>91</b>



# I INTRODUCTION

The utilization of wind energy has been tempting for centuries. Wind energy is most often and in most locations available and is renewable. The windmills of old times have been widely used in local energy production for grinding corn and pumping water to storage tanks in distant locations, in an isolated operation (islanding).

A big boom in wind energy utilization started in the 1990s when increasing energy prices, air pollution and people's awareness of limited fossil energy sources made people think of renewable and sustainable energy resources. Many countries started to support the development of wind energy utilization. For example, Denmark, Germany and the USA subsidized significant research and development projects, and a lot of wind power was installed in these countries during the first decade of this millennium. In recent times, contradictions have arisen due to the shut-down of nuclear power plants and the inexpensive prices of natural gas, oil and shale oil. In the well-known German "Energiewende", conventional coal-based power plants have started up, while North-German electricity transmission lines for the further harnessing of wind energy should be improved. The Scandinavian electricity market is gradually converting to a European electricity market.

Modern onshore and offshore wind turbines of wind farms convert the kinetic energy of wind to electricity using high-class technology with remote monitoring and operation. These turbines are able to produce energy with wind speeds from approximately 3 m/s up to 25 m/s, with a power up to 8 MW in a grid operation. However, there are many different kinds of challenges in implementing wind turbines for electricity production. In our society, uninterrupted electricity supply is expected at all times. When there is no wind at all or a stormy weather, the production of electricity must be ensured by some other means.

In the longer term, most expect that electricity prices will not fall. Most probably, future electricity should be produced using different sources, and in many ways. This review package provides readers with basic information on the utilization of wind energy.

# 2. WIND ENERGY RESOURCES

The radiation of the sun has a heating effect when it reaches the earth's surface. However, the earth's surface is heated unevenly, resulting in high and low pressure zones. Thus wind is a result of the natural balancing of the high and low pressure zones as seen in figure 2.1. An actual wind speed and direction on the ground is determined by both the pressure gradient between the high and low pressure zones and the Coriolis force caused by the earth's rotation. (U.S Department of Commerce, National Weather Service)

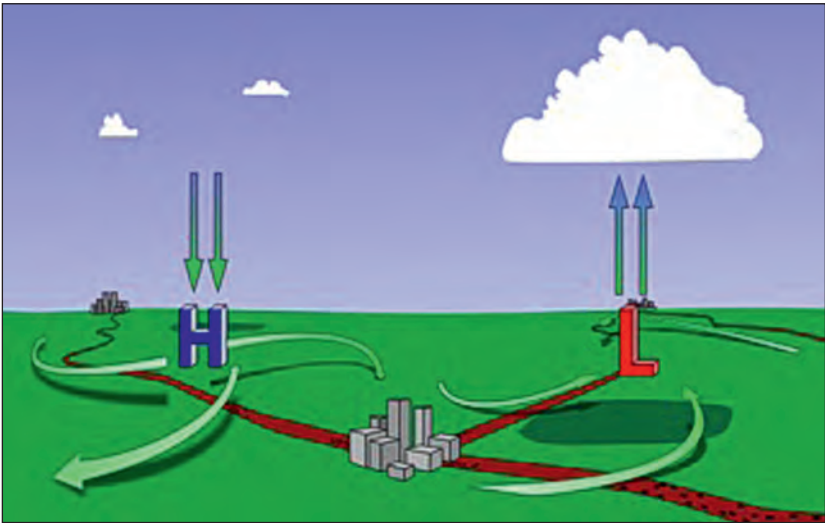

Figure 2.1. The effect of pressure zones on local windiness. (U.S Department of Commerce, National Weather Service)

The kinetic energy of the wind can be converted into mechanical rotational energy in wind turbines. The maximum power which can be harnessed from kinetic wind energy depends on the type of the turbine, and this efficiency is expressed by the power coefficient  $c_p$ . An ideal wind turbine can harness up to 59% of the kinetic energy of wind, and this limit is known as the Betz's limit. In real life, aerodynamical losses decrease the extracted power. With current wind turbine technology, about 45% of kinetic wind energy can be converted into mechanical energy. The mechanical energy is converted into electricity in a generator. Figure 2.2 presents the power coefficient of different turbine types (Huhtinen, p. 280 - 286).

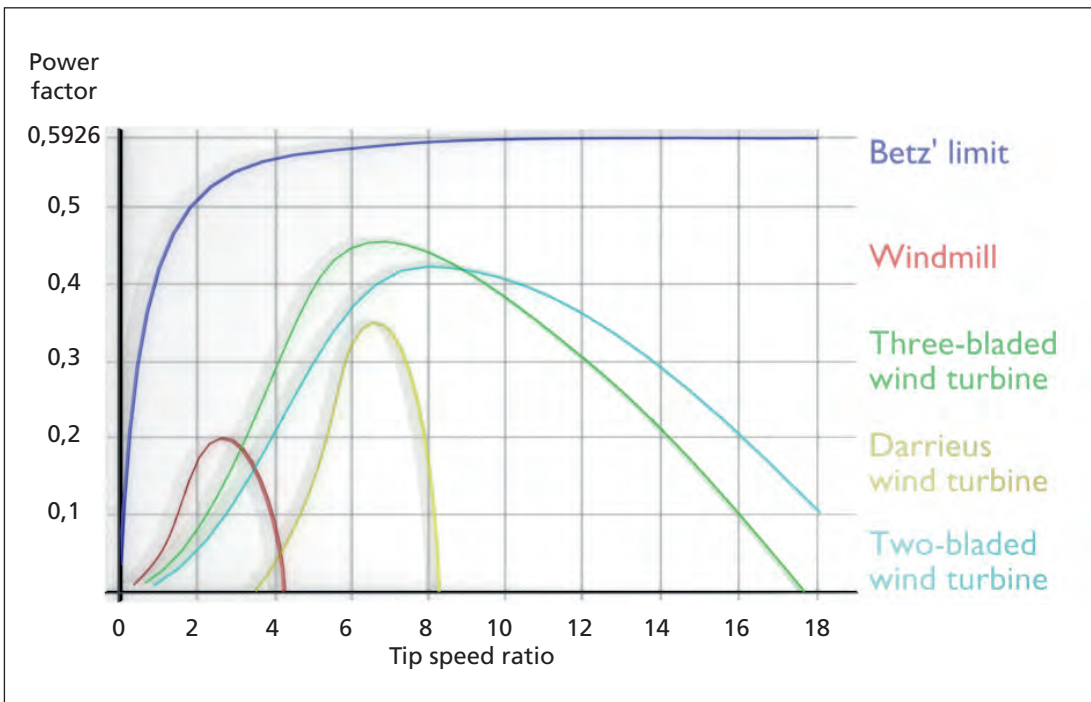

Figure 2.2 Wind turbine type power factor curves in a function of the tip speed ratio. Adopted from (Huhtinen, p. 285)

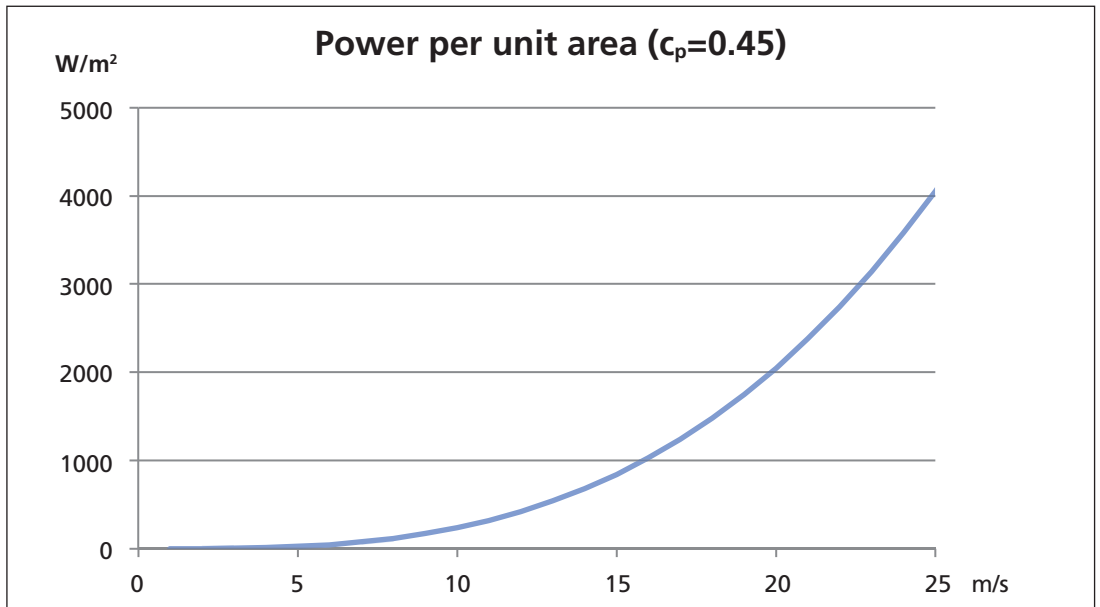

Figure 2.3 Power per unit area with power factor of 0.45.

Figure 2.3 illustrates the maximum available power of wind energy per unit area with a typical power coefficient of 0.45. For example, with current wind turbine technology the calculated theoretical power output for a wind turbine with a diameter of 70 m at wind speeds of 10 m/s is about 1.1 MW.

## 2.1 Wind atlas

The Finnish Wind Atlas was ordered by the Ministry of Employment and Economy and was produced by the Finnish Meteorological Institute. The Finnish Wind Atlas is based on the European weather forecasting model AROME and the Danish Wind Application and Analysis Program WAsP and is produced by analyzing the past 72 months. This model has also been verified with wind speed data from anemometer towers. (Finnish Wind Atlas).

The purpose of the wind atlas is to accumulate wind speed and direction data for different altitudes into a regional map. Wind atlas data is generally a combination of actual measured data and data from weather prediction models. The data of the wind atlas may be used in feasibility studies of future wind turbine and wind farm sites (Finnish Wind Atlas).

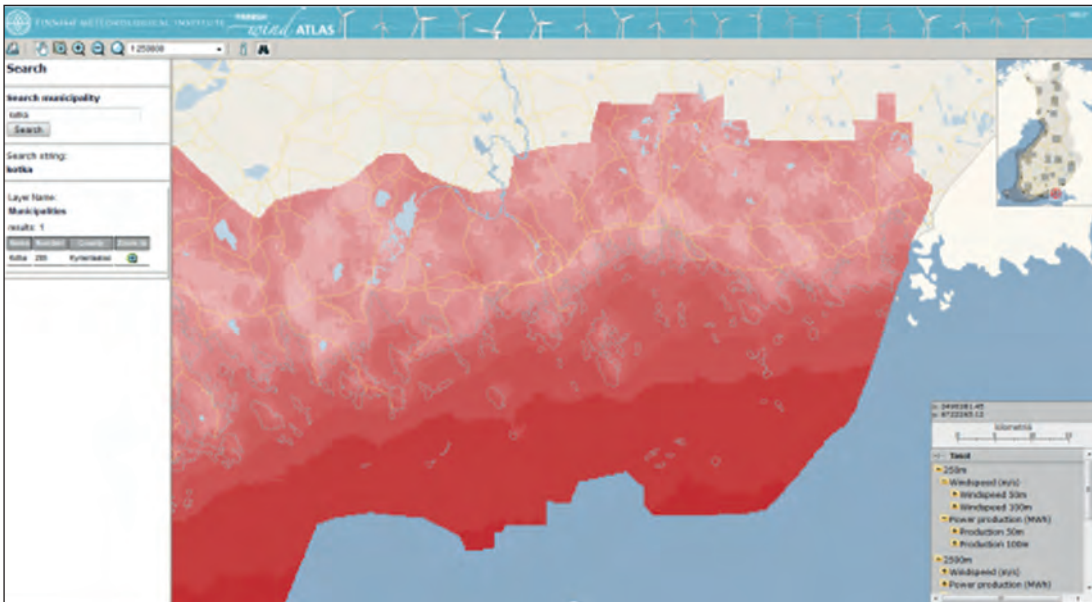

Figure 2.4 Average wind speed in the Kymenlaakso region (Finnish Wind Atlas).

Figure 2.4 is an example of January's average wind speed in the Kymenlaakso region of Finland at an altitude of 50 m. The darkest red region is about 10 m/s and lightest about 4.5 m/s.

## 2.2 Measurement of wind conditions

In feasibility studies, after pre-selecting possible sites from a wind atlas, more precise measurements should be made to assess the economical possibilities and wind shear of the wind turbine site. This measurement period should last at least one year but preferably up to three years. There are several feasible measuring instruments such as:

- Cup anemometer towers (Figure 2.5)
- LIDARs (LIght Detection And Ranging) (Figure 2.6)
- SODARs (SOnic Detection And Ranging). (Figure 2.7)

**Cup anemometer towers** consist of cup anemometers at different altitudes. The cup anemometer towers are reliable measurement arrangements, but are rather laborious in commissioning compared to portable and small LIDARs and SODARs. Anemometer towers are considered to be reliable measurement instruments, and LIDARs and SODARs are mostly calibrated according to anemometer towers.

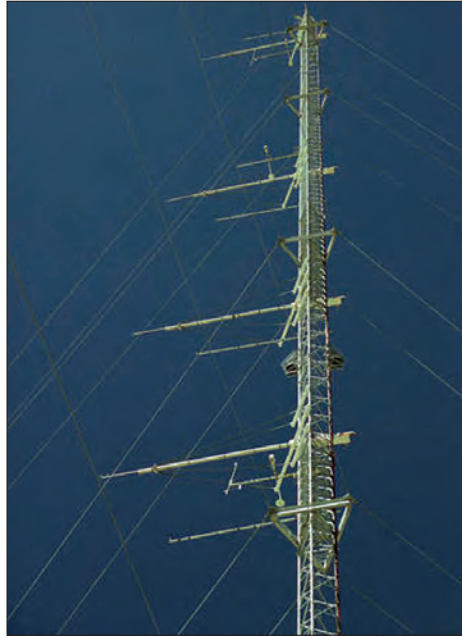

Figure 2.5 Cup anemometer tower (U.S. Department of Energy, National Renewable Energy Laboratory)

**LIDARs** are based on a doppler shift of emitted and received light signals. A lidar can measure wind speeds and directions simultaneously at different altitudes. The most commonly used wavelengths are from 600 to 1550 nm. The lidars consist of a laser emitter, optics, photodetector and receiver. Lidars are considered to be accurate instruments and perform especially well in determining wind gradients. (LIDAR and SODAR Measurements of Wind Speed and Direction in Upland Terrain for Wind Energy Purposes)

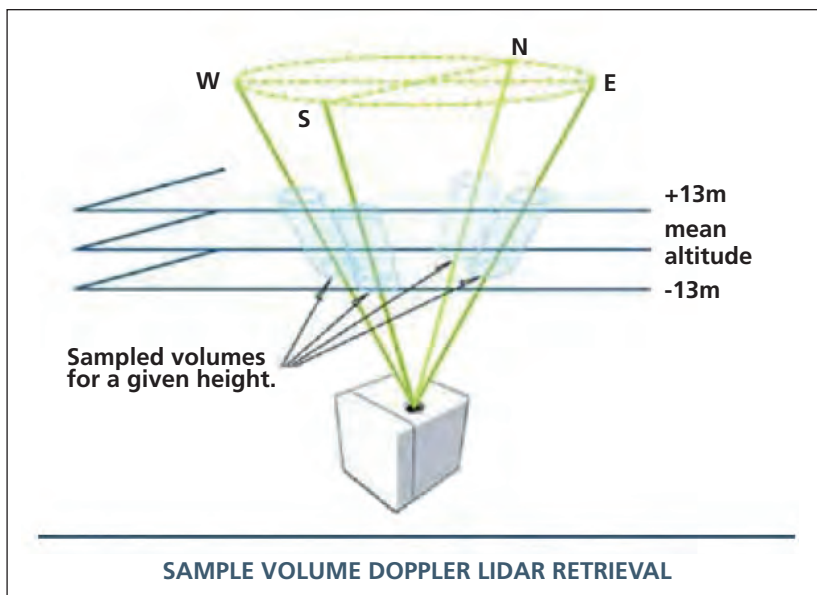

Figure 2.6 LIDAR principle (Alpha Wind Energy)

**SODARs**, like LIDARs, are based on the doppler shift of the emitted and received signals, while SODAR uses sound signals instead of light signals. A sodar can measure both wind speeds and wind directions at different altitudes simultaneously. Operation frequencies of the emitted signals range from 1,000 Hz up to 4,000 Hz, and power levels are several hundred watts. The sodar consists of an acoustic emitter (piezo element) and an acoustic receiver (microphone). (LIDAR and SODAR Measurements of Wind Speed and Direction in Upland Terrain for Wind Energy Purposes)



Figure 2.7 Kyamk Sodar (Häkkinen)

## 2.3 Literature references

Alpha Wind Energy, LIDAR. [http://alphawind.dk/lidar\\_campaign](http://alphawind.dk/lidar_campaign) [Viewed 17.12.2013]

Finnish Wind Atlas. <http://www.windatlas.fi/en/index.html> [Viewed 17.12.2013]

Finnish Wind Atlas. Map Interface <http://tuuliatlas.fmi.fi/en/> [Viewed 17.12.2013]

Huhtinen, M. Korhonen, R. Pimiä, T. Urpalainen, S. Voimalaitostekniikka. 2008. Otava.

Häkkinen. Kyamk Sodar photos.

U.S Department of Commerce, National Weather Service. 2010. Origin of the wind.

<http://www.srh.noaa.gov/jetstream/synoptic/wind.htm> [Viewed 17.12.2013]

U.S. Department of Energy, National Renewable Energy Laboratory. 2005. Anemometer tower. <http://www.nrel.gov/midc/llljp/pictures.html> [Viewed 17.12.2013]

University College Cork. LIDAR and SODAR Measurements of Wind Speed and Direction in Upland Terrain for Wind Energy Purposes. <http://www.mdpi.com/2072-4292/3/9/1871> [Viewed 17.12.2013]

## 3 WIND TURBINE TECHNOLOGY

A wind turbine converts kinetic energy into rotational energy. This rotational energy is then converted into electricity by using generators. In Finland, the power capacity of a typical wind turbine is from 200 kW to 3 MW. The most common turbine size class is from 2 to 3 MW. There are wind turbines in production which have a capacity of 3 to 5 MW, a tower height of 80 to 140 meters and a rotor diameter of 80 to 140 meters (Energiateollisuus. 2013).

### 3.1 Wind turbines and their constructions

Wind energy production varies daily depending on wind conditions. Higher wind speeds produce more energy until the rated power is achieved. After the rated wind speed has been reached, the power remains approximately constant up to the cut-out speed of a wind turbine. The cut-in speed of a wind turbine is usually about 2 - 4 m/s and the cut-out speed about 25 m/s. The cut-out speed aims at preventing any damage caused by high wind speeds and storms.

There are five different types of wind turbines of which the three-bladed horizontal-axis propeller turbine is the most common in commercial energy production. Other turbine types include the three-bladed vertical-axis cup rotor, Savonius rotor, spiral rotor and Darrieus rotor. When speaking of wind turbines, we are referring to three-bladed horizontal-axis wind turbines (HAWTs) in this paper (Huhtinen. p. 281).

In commercial energy production, propeller-type turbines have replaced other turbine types because of their cost-efficiency. The propeller-type turbines are the most cost-effective wind turbines because they have a high swept-area compared to material costs. Three-bladed wind turbines have become more established than two- and one-bladed turbines because of their more stable rotation (Huhtinen. 2012. p. 281).



A wind turbine consists of a hub, nacelle cover, drive train system, tower, foundation, and blades (Figure 3.1). In the propeller turbine, the rotor and nacelle are located on the top of the tower which makes maintenance more difficult but enables better utilization of wind energy because of higher altitude. A yaw system takes care of the rotor and nacelle orientation against the wind (STY. 2003).

The rotor blades of a wind turbine are usually made of composite materials such as glass fiber, carbon fiber or wood with epoxy resin or polyester. The output power of a wind turbine can be adjusted either by stalling or by a pitch control. Stall controlled wind turbines are stopped using a pinion gear break. On the other hand, wind turbines with pitch control are stopped by turning the blades so that the leading edge of the blade is directly against the wind. When the turbine has stopped, it is locked down using a mechanical break (Manwell 2009, 359 -364) (STY 2013).

Wind turbine towers can be made of steel or concrete cylinders, steel frames or hybrid solutions. In Europe tubular steel structures are commonly used while in the USA steel frame towers are

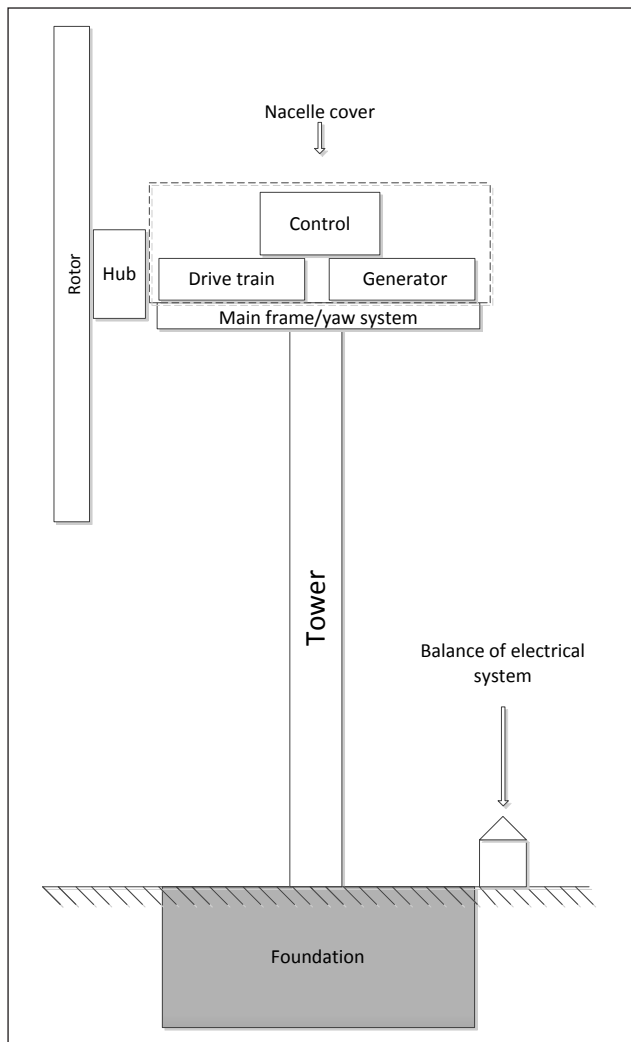

Figure 3.1 Components of a wind turbine. Adopted from (Manwell 2009, P 4)

widely used. With steel frame towers it is possible to achieve much higher hub heights. In Finland there are plans to implement hybrid towers, in which the lower parts are concrete and upper parts steel. These hybrid constructions usually contain 50% concrete and 50% steel (STY. 2003).

Wind turbines can be erected either onshore or offshore. A land foundation can be a ground slab which can be piled or anchored in the bedrock if the on-site ground is soft. Sea foundations are open caissons if the water depth is less than 15 meters, or piled foundations with significantly smaller surface areas. Mutual distances between wind turbines are usually several hundred meters. These distances are dependent on rotor diameters, a number of wind turbines and location patterns. For example, 3 to 5 MW turbines should be spaced from 400 meters to 1,000 meters apart (Ympäristöministeriö. 2012, P. 10).

Wind turbines are classified related to wind condition classes according to the international standard IEC-61400-1. Wind measurement determinates' average wind speed in the lowest and highest location of rotor blades are determined by wind measurements described in chapter 2.2. The difference of the wind speed in the highest and lowest region of the rotor blade is called wind shear. The wind shear should not exceed 20% (Vaasa Energy Institute. 2013).

There are several types of usable tower constructions but the most common construction is a tower built from stacked steel cylinders. Modern wind turbines are usually around 100 meters high and have a rotor diameter of around 120 meters. These specific wind turbines have a concrete base that usually weighs around 1,000 tonnes and consists of reinforced concrete. The cylinders of the tower can be as heavy as 80 tonnes per fragment. Usually these kinds of towers consist of 6 cylinder parts. On top of the tower is a nacelle that weight from 80 to 120 tonnes (Päivinen, 2013. p. 13).

The wind turbine nacelle contains the parts utilized in converting the wind energy to electricity. The components that are usually placed in the nacelle are presented in the figure 3.2.

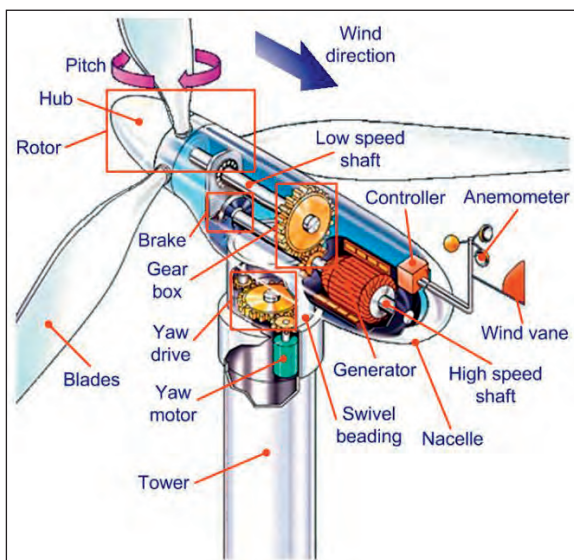

Figure 3.2 Wind turbine parts (Marcelo Gustavo Molina, Juan Manuel Gimenez Alvarez. Technical and Regulatory Exigencies for Grid Connection of Wind Generation. 2011)

Electrical systems are extended in many activities of a wind turbine. Electrical systems can be considered to include everything from control of the wind turbine to grid connection. This includes instrumentation, control systems, wiring, generators, transformers, as well as other electrical systems.

### 3.2 Drivetrain concepts

The drivetrain is the key element in the conversion of wind power to electricity. Therefore the drivetrain must be efficient, reliable and needs to have good serviceability. Drivetrain systems consist of four major components which are an axle, a gearbox, a generator and a power converter. Some sources have slightly different definitions of drivetrain systems. Some include whole generators in the drivetrain systems, while others include only the rotating parts of generators. In this paper, generators as a whole excluding the power converter are included in the drivetrain concept.

Traditionally a drivetrain system consists of a 3-stage gearbox, a high speed induction generator and a power converter. This assembly is often called the “Danish concept”. Modern wind turbines use alternative assemblies due to the fact that this old-fashioned assembly has many flaws, including a high gearbox failure ratio. New generator technologies, like PM generators, have made it possible to utilize direct-driven assemblies. These assemblies have less moving parts thereby reducing the overall failure rate of wind turbines. Modern assemblies may also include a low-speed ratio gearbox or multi generator solutions (Pyrhönen. 2013). The following figure 3.3 illustrates the drivetrain of a wind turbine. The area inside the box formed by the red line is the drivetrain. This is the general assembly but may vary depending on the generator type and other factors. These other solutions are dealt with later on in this chapter 3.

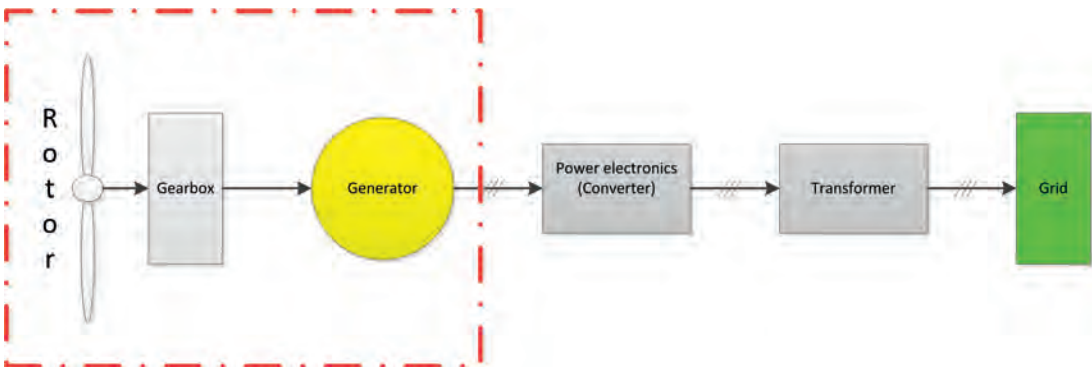

Figure 3.3 Drivetrain of wind turbine.

The following drivetrain assemblies are common in wind turbines:

- two-speed or fixed speed asynchronous generators
- doubly-fed induction generator (DFIG)
- permanent magnet synchronous generator (PMSG)

Figures 3.4, 3.5 and 3.6 illustrate the basic structure of the assemblies for converting the wind energy into the electricity in a simplified manner.

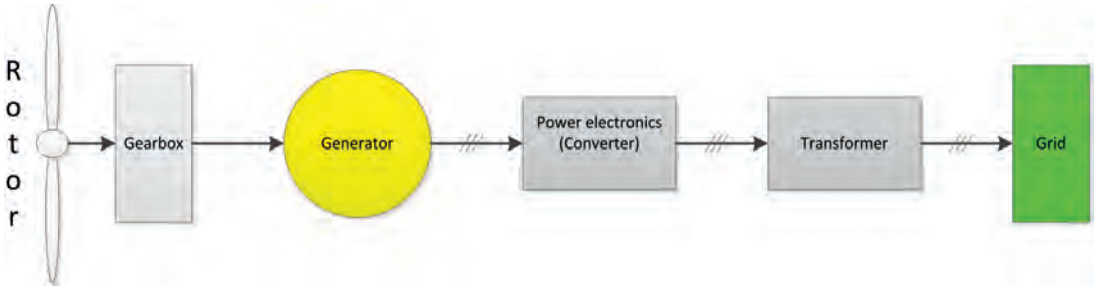

Figure 3.4. A traditional fixed-speed drivetrain concept with separate gearbox and generator

Permanent magnet systems have been coming into wind power production as they offer a simplified mechanical structure compared to the traditional solution. This is due the fact that a gearbox is not needed. Figure 3.5 presents the concept of the variable speed PMSG assembly.

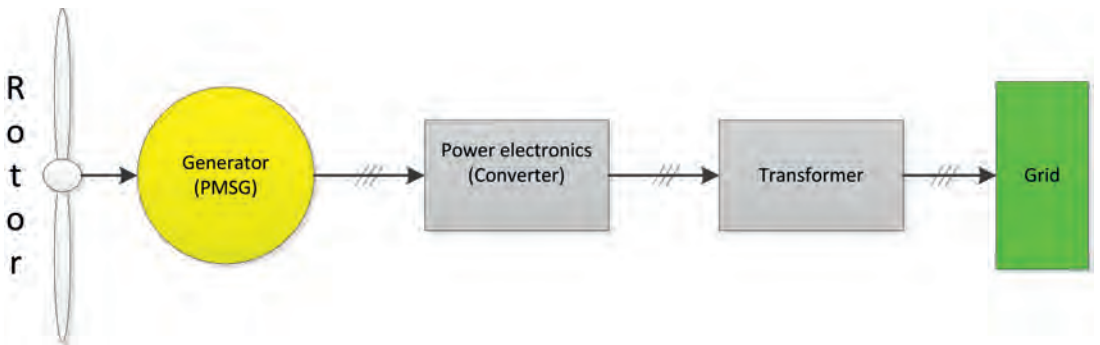

Figure 3.5. Gearboxless direct-drive drivetrain utilized in current high efficiency wind turbines

Figure 3.6 is a hybrid solution with a gearbox and generator integrated as one item. This concept has the benefits of both a gear and permanent magnet generator. However, at a lower scale of nominal power, efficiency suffers from gearbox losses.

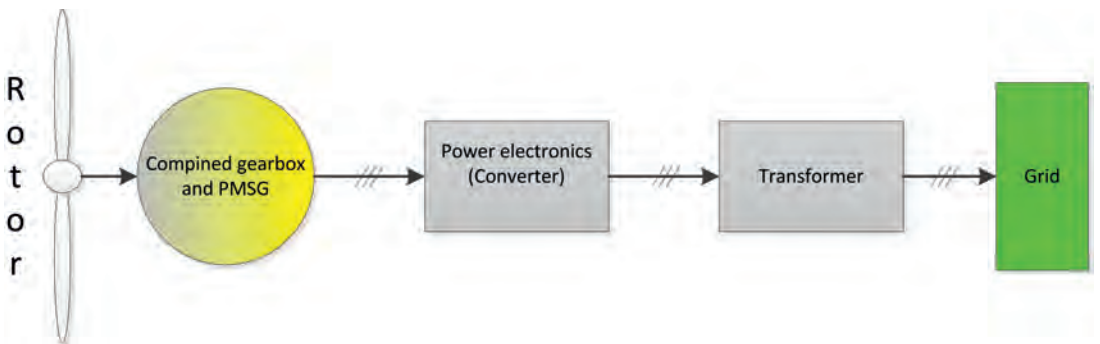

Figure 3.6. Hybrid drivetrain

As stated previously in this chapter, drivetrain efficiency is affected significantly by the gearbox and generator. It is clear that each type of drivetrain assemblies has its own benefits. There are also financial points which must be taken account as they will affect the investment and feasibility of the wind turbine. Figure 3.7 illustrates the efficiencies of different drivetrain solutions.

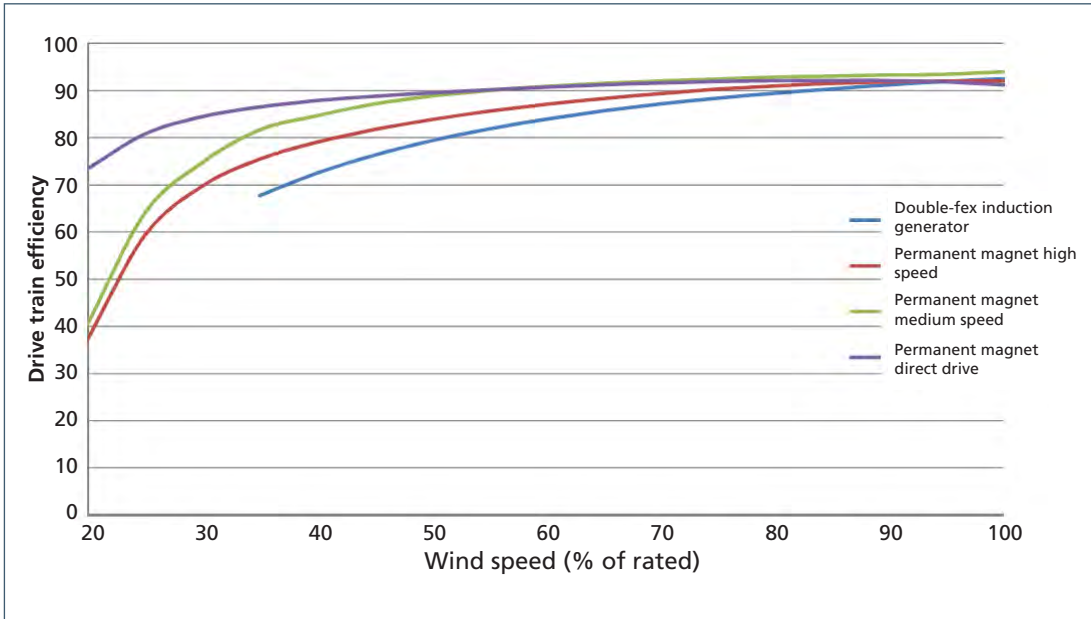

Figure 3.7. Efficiencies of the different drivetrain systems in the function of rated wind speed (Pyrhönen, 2013)

Drivetrain solutions have evolved much since the 1980s. The first wind turbines mostly utilized fixed speed generators and DFIG solutions. In the 21<sup>st</sup> century, new drivetrain solutions have mostly superseded these traditional fixed speed solutions. One of the latest solutions is to utilize permanent magnet generators with a power transformer. The main advantage of PMSG is the increased drivetrain efficiency from low to high wind speeds. It is predicted that the new technologies will bring superconducting generators into wind power production by about 2020, thus pushing drivetrain efficiency even further. The development of wind turbine drivetrain solutions is presented in the following figure 3.8.

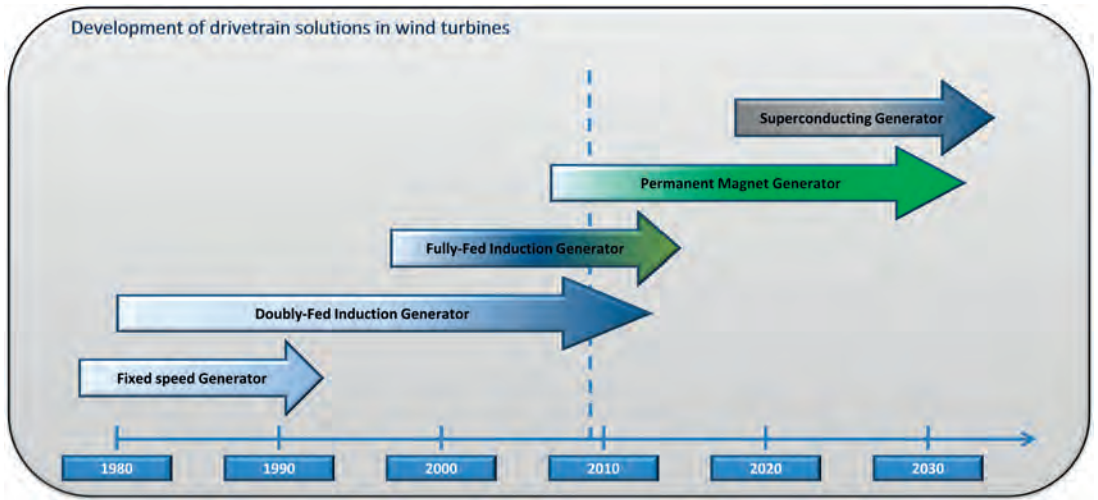

Figure 3.8. Drivetrain alternatives in wind turbines. Adapted from (Pyrhönen, 2013)

### 3.2.1 Gearboxes

The equation of the gear ratio is given in the equation 3.1. This equation describes the effect of the gearbox that is used:

$$k = \frac{n_2}{n_1}$$

Equation 3.1. Gear ratio

where

$k$	gearbox ratio	-
$n_2$	rotation speed of the second gear	<i>rpm</i>
$n_1$	rotation speed of the first gear	<i>rpm</i> .

The gear ratio is an essential part of wind turbine design. In various wind turbine assemblies, the rotational speed of the rotor is not enough to generate electricity and therefore the rotation speed must be significantly raised with the gearbox. The equation 3.2 shows us that the mechanical power extracted from the wind must be transferred on the generator. This equation does not account for mechanical losses (PYRHÖNEN, 2013):

$$P = T_1 * \omega_1 = T_1 * \frac{n_1}{60} * 2\pi = T_2 * \frac{n_2}{60} * 2\pi$$

Equation 3.2 Mechanical power extracted from wind

where

$P$	power	$V$
$T_1$	torque on the first gear	$Nm$
$T_2$	torque on the second gear	$Nm$
$w_1$	angular velocity of the first gear	$\frac{rad}{s}$
$w_2$	angular velocity of the second gear	$\frac{rad}{s}$

Generally wind turbine gearboxes have quite high efficiency of approximately 98%. In traditional solutions the gearbox gear stages are typically planetary gears which consist of planetary and helical gears. It is possible to achieve a gear ratio of 1:6 by using one planetary stage. Usually in these gearboxes, the gear ratio is approximately 1:100 or more if needed. In a gear system, planetary stages are used at the low-speed end, and helical stages are used at the high-speed end. (Pyrhönen. 2013. p 7).

Gearboxes have mechanical losses which produce heat. The heat produced must be dissipated from the gear system and thus gear boxes require oil cooling. The heat from the hot oil is dissipated in the oil to air heat exchanger (Pyrhönen. 2013. p 7).

One example of a typical gearbox would be a wind turbine with a rotor rotating at a maximum speed of 19.1 rpm and a generator requiring a rotation speed of 1,700 - 1,800 rpm. This generator requires a gearbox with a gear ratio of 89 - 94 which equals about 3 gear stages at the minimum (Pyrhönen. 2013. p. 9).

### 3.2.2 Generators

A generator is an electric machine which converts mechanical energy into electrical energy through electromagnetic induction. The rotor extracts the energy of the wind by transforming it into mechanical energy which is in this case the rotational energy. This rotation energy is transferred either directly or indirectly to the generator. In the older wind turbines, this is done through a gearbox which converts the rotation speed of the axis into rotation speed suitable for the genera-

tor. In modern wind turbines, the gearbox can be left out of the assembly using advanced power electronics and generators such as a permanent magnet synchronous generator (PMSG).

Wind turbine generators are mainly induction generators with some exceptions. Direct current generators are only utilized in small-scale wind turbines, and this report will not describe them in detail. Wind turbines utilize both synchronous and asynchronous generators, and the type of generator depends on the chosen assembly.

Electromagnetic induction is a natural phenomenon in which an alternating magnetic field generates an electric field. This phenomenon is described by Faraday's Law. In generators, electromagnetic induction is utilized to generate electricity from rotation energy (Korpela. 2012). The working principle of the generators is illustrated in Figure 3.9. This shows the generator as a simplified structure for the sake of clarity. In reality, generator assemblies are much more complex with more magnetic poles and armature loops.

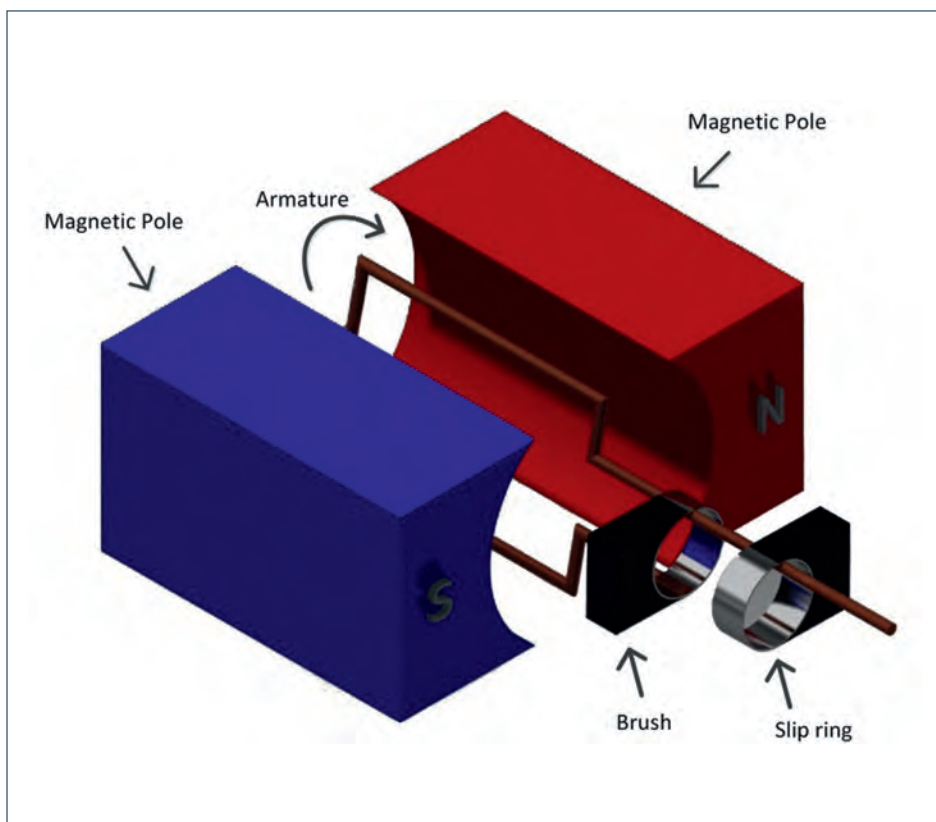

Figure 3.9 Simplified structure of basic induction generator

Wind turbine generators can be divided into synchronous and induction generators. Some companies offer wind turbine generators within a power range of 100 kW to 7 MW, and even up to 20 MW. However, current wind turbine assemblies are designed to produce power from 3 MW to 5 MW. These ratings are achieved with tower heights of 100 to 140 meters and rotor diameters up to 154 meters (ABB. 2013).



The synchronous generators can be realized with various technologies but this report will focus on permanent magnet systems. This is due the fact that these PM generators are becoming more common and offer easy solutions for direct drive systems. The PMSG is feasible in medium- and high-speed applications, and this generator type was specifically developed for these applications (ABB. 2013).

Low-speed PMSGs offer high efficiency with maximum reliability. This is due to the fact that the assembly is simple and robust. This also leads to low maintenance demand because there is no gearbox and the rotor directly drives the generator providing a more compact and simplified system. This makes installation and maintenance easy. In general, these PM systems have longer lifetimes because they have less moving parts. Only direct-driven assemblies are discussed hereafter. (ABB. 2013).

Medium-speed PMSGs come in various assemblies. It is possible to have fully integrated concepts where the generator and gearbox form an integrated unit. It is also possible to have semi-integrated concepts where the generator is integrated into the gearbox through a supporting flange. The third method uses a modular construction where the generator and the gearbox are separate units (ABB. 2013).

Figure 3.10 presents the generator types. It does not include all the generator types that exist but instead it focuses on the generators which are utilized in wind power production.

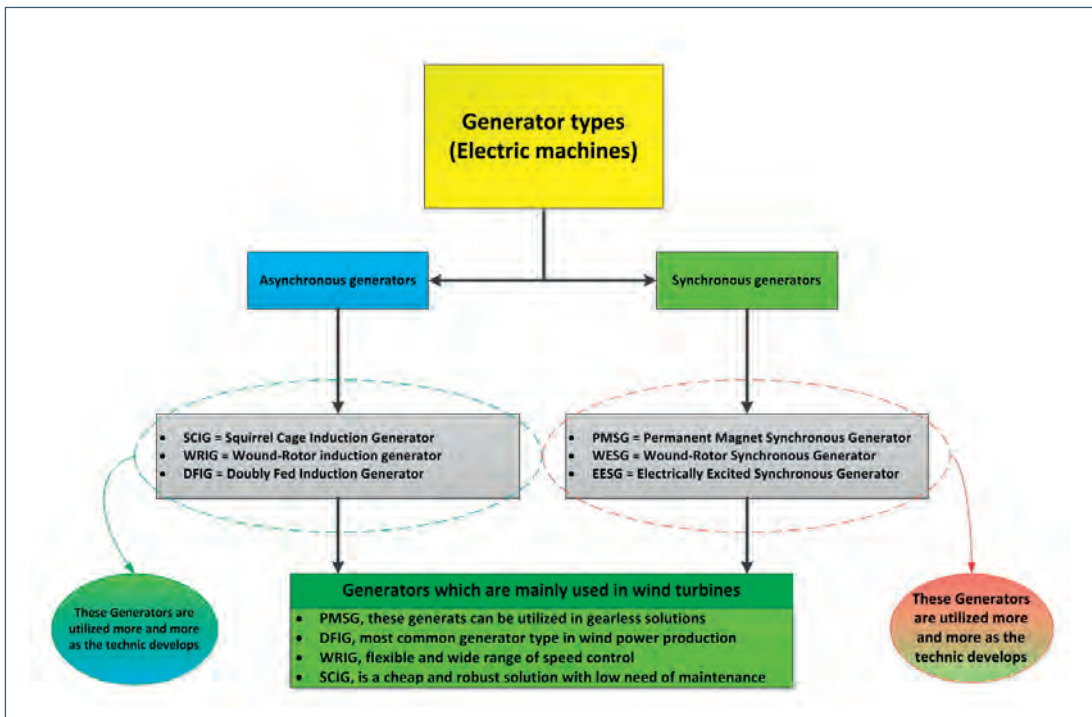

Figure 3.10 Generator types and main generator types in wind power

### 3.3 Grid connection

Wind turbines cannot be directly connected to grids due to varying power outputs. Wind turbines are like winds – always changing their output parameters and in an unpredictable way. Different devices such as transformers, inverters, switches, etc. need to be used between grids and wind turbines. Nowadays, the grid connection of a wind turbine is one of the biggest and most challenging issues in this field of electricity production.

Different kinds of faults may happen in wind turbines. These faults have different kinds of impacts. Some faults may be very serious and the wind turbines in question must be shut down immediately. A number of sensor faults are possible. For example, pitch position sensors may have electrical or mechanical faults, and in fault circumstances measured values are not reliable. Fatal sensor faults can lead to unpredictable chains of controller operations, and even shut down a wind turbine.

#### 3.3.1 Devices used for grid connections

Wind turbines can be connected to grids using different voltage levels: low, medium, high and extra high voltages. A turbine rotor, a generator and a gear box are the main components for electricity production (Figure 3.11). The rotor converts wind energy into mechanical energy. The generator converts the mechanical power of the rotor into electrical energy which is then fed into a grid. The rotor speed is adjusted to the generator speed using the gearbox. The required frequency for the output power is achieved by a DC link.

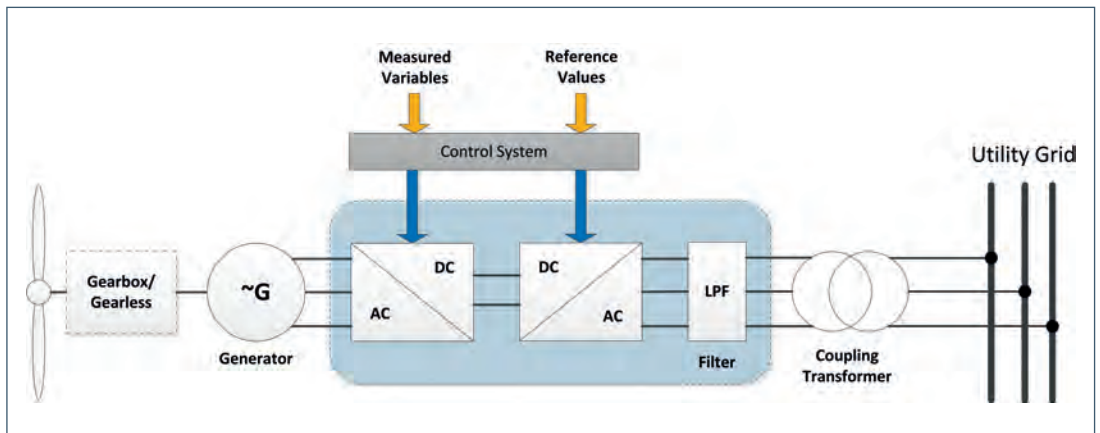

Figure 3.11. Connection of wind-turbine to the grid adopted from (Intechopen 2013)

The main grid connection components of the wind turbines are a transformer, safety equipment (circuit breaker) and electricity measurement and control devices (Figure 3.12). In order to reduce losses in low-voltage lines, each wind turbine of a wind farm is provided with its own

transformer which converts the voltage level of the turbine to the voltage line of the grid. Those transformers are located in the direct vicinity of the wind turbines, and less cabling is needed. Small wind turbines can be connected to user grids using one transformer. Large wind farms need separate substations for the transformation of medium voltage levels to high voltage levels. Between a wind turbine and the grid, at the point of common coupling (PCC), a circuit breaker must be installed to provide disconnection in case of faults. A circuit breaker is usually installed in a medium voltage system.

Distribution transformers are often used in the 5 - 50 kVA range. Transformers in substations have power ranges between 1,000 kVA and 60,000 kVA. Transformers are provided with primary and secondary winding coils (Manwell et.al. 2009, 217).

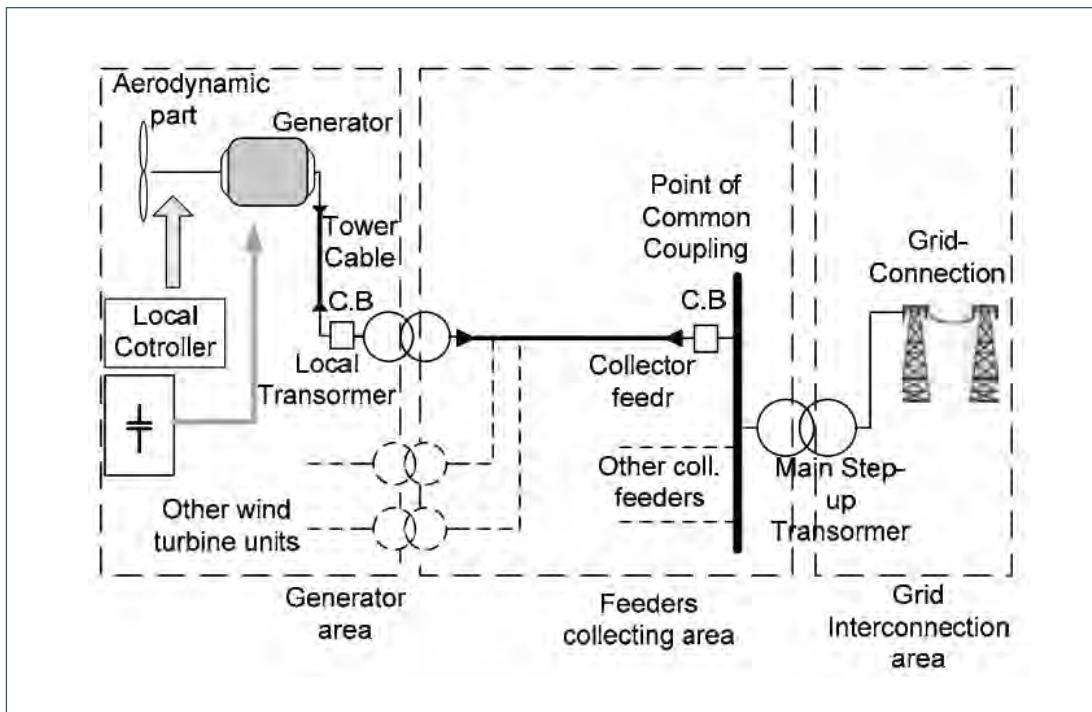

Figure 3.12. Connection of a wind turbine to a grid (Kawady et.al. 2007, 269).

Power from generators must be transferred to local transformers. There are circuit breakers and fuses between the generator and the electrical grid. The circuit breakers are used for connection, disconnection and protection purposes. The fuses are used only for protection aims. Circuit breakers can be reset after fixing the fault. Fuses must be replaced.

### 3.3.2 Grid protection

A protection system is one of the most important parts in the grid connections of wind turbine generators to networks. Networks are usually protected using overcurrent protection schemes. The connection of a wind turbine to a grid always influences existing protection schemes.

A short circuit level is the basis for the selection of circuit breakers, fuses, current transformers, reclosers and overcurrent relays. When a wind turbine is connected to a grid, an equivalent network resistance can decrease and this may lead to faults. High fault currents can exceed the capacity of existing circuit breakers.

Induction generators make a limited contribution of fault currents to asymmetrical faults. Small synchronous generators are not able to supply fault currents. Power semiconductor devices cannot withstand significant overcurrent and therefore power electronic converters are designed to restrict output currents internally.

Islanding is a situation where a part of the network is disconnected from the main grid, and this part operates like an independent system with one or more generators. Islanding results when there are variations of frequency and voltage. If an auto recloser opens during a fault situation, it may make two independent systems with different frequencies. The reclosing of the auto recloser while the two systems are out of phase could bring disastrous results. Islanding is recognized as an unsafe situation as a result of which immediate disconnection of the generator from the grid is needed.

### 3.3.3 Voltage control

The interconnection of wind turbines with grids makes changes in power flows and voltage profiles in the power feeder, and also may result in overvoltage.

The selection of tap joint settings for transformers becomes difficult with an increased amount of connected wind turbines. When the wind turbines are not equally distributed, it becomes more difficult to set appropriate tap joints for transformers. Such a case is shown in Figure 3.13. While there are two feeder bars supplied by the same transformer, the wind turbines are only connected on one feeder bar. When the wind turbine is connected, the current through the transformer is decreased because the wind turbine supplies the nearby loads. Thus the transformer tap joint should be changed to a light load setting. The resulting voltage can cause a voltage disturbance at the end of the feeder without any wind turbines. When leaving the transformer tap joint in heavy loads, it can cause overvoltage in the feeder bar with wind turbines.

The feeder bar voltage can be controlled using switched capacitors and static compensators but these solutions are often too expensive.

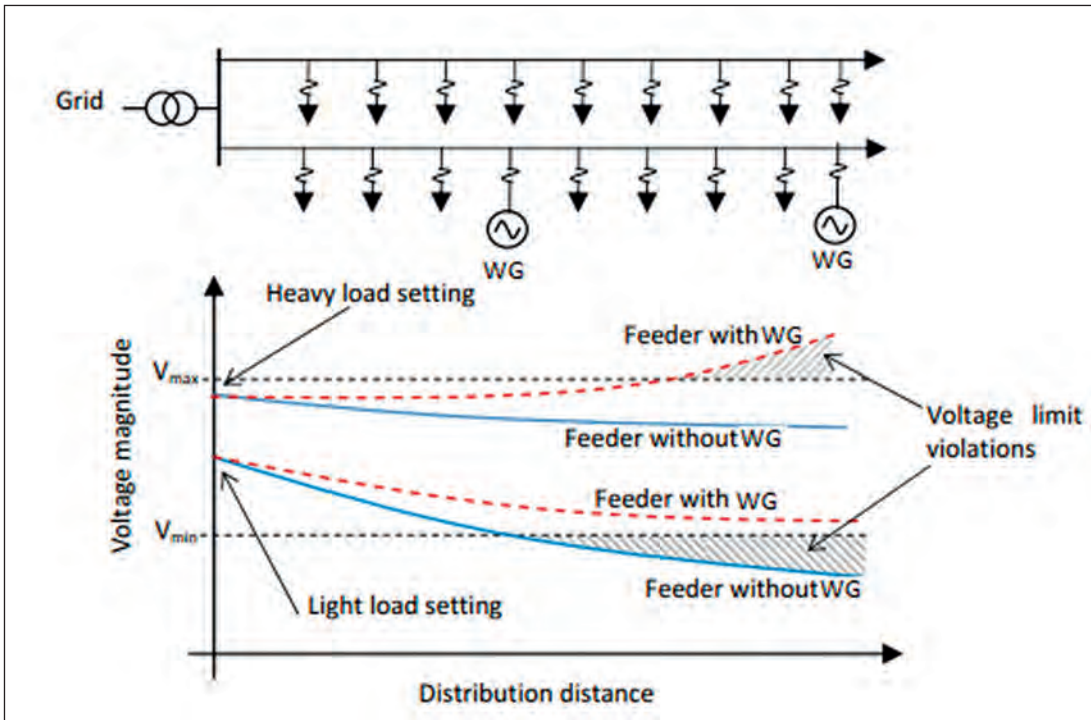

Figure 3.13. Impacts of tap joint settings (Rajapakse et. al. 2006, 112)

Another connection effect of wind turbines is an unbalanced voltage profile. As illustrated in Figure 3.14, three-phase and single-phase loads and connections of wind turbines may be used. The single-phase connection increases imbalance. These unbalanced distribution systems can cause problems for the three-phase connected wind turbines. Unbalanced currents can cause overheating and frequent shutdowns of wind turbines.

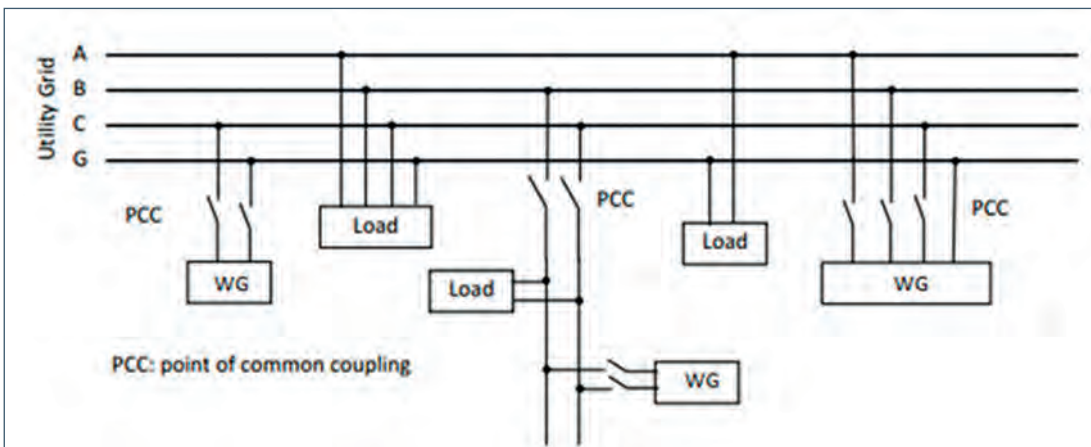

Figure 3.14. Single-phase and three-phase loads and connections of wind turbines (Rajapakse et.al. 2006, 113)

The interconnection of wind turbines with the grid causes different undesirable effects, such as harmonics, voltage and frequency fluctuation, active and reactive power flow. To avoid disturbances and damage to the system, grid effects should be monitored and controlled.

### 3.3.4 Power output behavior

When connected in grids, wind turbines have an impact on real and reactive power and may result in voltage and current transients or voltage and current harmonics. Constant-speed turbines usually use induction generators. Induction generators produce real power for the grid and consume reactive power from the grid. Real and reactive power variables are constantly changing during the operation of wind turbines. Real low-frequency power fluctuations occur when the average wind speed changes. Higher frequency fluctuations of real and reactive power occur due to wind turbulence, the dynamic effects of drivetrain systems and blade vibrations.

Wind turbines with synchronous generators operate in a different manner to induction generators. When connected to large electrical grids with a constant voltage, the excitation field of synchronous generators can be used to change the line power factor and to control reactive power.

Variable-speed wind turbines usually have a power electronic converter between the generator and the grid. This converter is able to control the power factor and voltage. Power electronic converters should supply reactive power to support the magnetic field of the generator. The converter components can provide current to the grid at any power factor. This can be used to improve grid operation. When generators are connected or disconnected, voltage fluctuations and transient currents may appear.

When an induction generator is connecting, a significant overcurrent appears. These high currents can be limited using soft-start circuits. When induction generators are disconnected from the grid, voltage spikes can occur. Synchronous generators have no high starting current requirements. Nevertheless, voltage transients can still occur.

Wind turbines must be able to operate continuously even if the voltage and frequency variations in normal operation are in the feasible range but differ from nominal values. This ability depends on the voltage level at the point of common coupling (PCC) of the wind generator and the grid. The transmission-level voltages are 110 kV and above. The lower voltages, such as 35 kV and 10 kV, are used as sub-transmission voltages. Voltages of less than 35 kV are used for distribution. Voltages above 220 kV are extra high voltages and special devices should be used.

The lowest voltage level in most countries must not be lower than 90% of the nominal value. In some countries, the voltage can drop to as low as 70% of the nominal value but only for 10 seconds.

The frequency varies country by country. Most electric power is generated at frequencies of 50 or 60 Hz. All the generating equipment must operate at strict frequency. Usually the frequency variation range is from 49.5 Hz to 50.5 Hz. Deviations from the nominal frequency for even a short time may lead to the loss of generation capacity. Further frequency deviation may lead to blackout. In the full-load range, wind farms should supply their nominal power without any disturbances (continuous operation area in the figure 3.15).

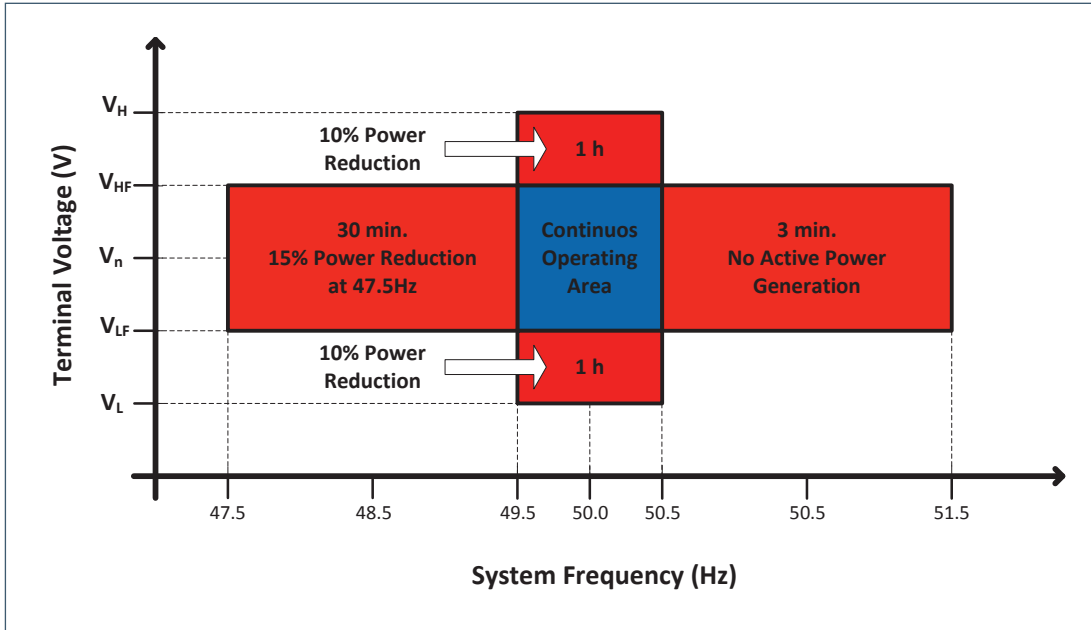

Figure 3.15. Typical voltage and frequency dimensioning for wind generators adopted from (Molina and Alvarez 2013)

In the diagram of Figure 3.13, the following symbols are used:

- VL lower voltage limit
- VLF lower voltage limit for full-load range
- VN nominal voltage
- VH upper voltage limit
- VHF upper voltage limit for full-load range.

The harmonics are voltage components with frequencies being multiples of the nominal frequency 50 Hz, i.e., 100 Hz, 150 Hz, 200 Hz, etc. The interharmonics are components with frequencies located between the harmonics of the nominal frequency. Voltage and current harmonics and interharmonics are always present on the utility grid. They mainly come from the rectifiers and inverters of electric drives, non-linear loads, power electronic loads, etc. There are many negative effects of harmonics, such as:

- distortion of the supply voltage
- voltages drop in the distribution network

- the effect of harmonics that are multiples of three (in three-phase systems)
- resonance effects on the frequencies of the higher harmonics
- interferences in the telecommunications and control networks
- increased acoustic noise in the electromagnetic equipment
- vibration in the electric machine systems.

The long-term phenomena of harmonics include:

- heating and additional losses in transformers and electrical machines;
- heating capacitors;
- heating cable distribution network.

Different kinds of filters can be utilized to reduce the impact of harmonics.

### 3.3.5 Power quality and grid connection rules

Power quality can be expressed in terms of voltage, frequency and their variations. A perfect voltage has a sinusoidal voltage waveform with a constant amplitude and frequency. A classification of different phenomena affecting power quality is presented in Figure 3.16.

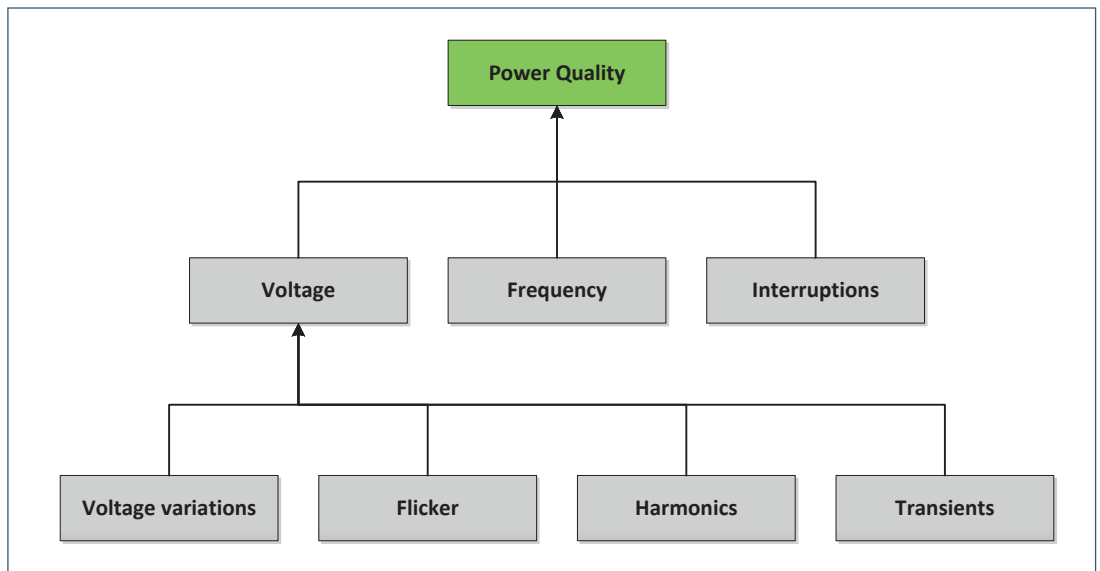

Figure 3.16. Classification of different power quality phenomena.

According to international standards, the quality of the voltage should be met to allow a power source to become connected to a grid. The voltage disturbances are divided into several categories: flickers, voltage variations, harmonics and transients distortions. Wind turbines affect power quality, and wind turbines are affected by disturbances coming from the grid. Large power systems usually have a stable frequency, and wind turbines do not normally cause interruptions in high-



voltage grids. In autonomous grids with diesel engines or wind turbines, the frequency variation should be taken into account.

The first grid code in the world, regulating the procedure of connecting wind farms to grids, was performed in Germany in 2003. The main points of interest of this document are:

- operation of wind farms in the network during faults (short-circuit current)
- creating an intelligent system for separating different groups of wind turbines in wind farms to separate loads (islanding)
- reconnection of wind turbines to wind farms with a minimum voltage or frequency deviation.
- minimizing power losses of wind power plants.

At the moment in every European power system, there are some technical requirements for connecting wind farms to grids. These documents are generally classified by the voltages of networks. The first group includes documents regulating wind farm connections below 100 kV, and the second group networks above 100 kV. The basic requirements are:

- maintaining the required frequency
- maintaining the required voltage
- monitoring the power quality
- protection and management of the wind farm.

In general, the output power of wind farms should be uniform and have only seasonal fluctuations when the winds change. It is very difficult to avoid seasonal fluctuations of the output power. If the output power of a wind farm reaches 15 - 20% of the installed capacity of the whole unified power system, the wind farm power fluctuations can affect the dynamic stability of the power system. While in some European countries, the share of wind energy exceeds 30% of the capacity of national unified energy system, for example in Denmark, the maintaining of the required frequency near its nominal value is really important. The basic requirement for wind farms related to the frequency is  $50 \pm 0.5$  Hz for 97% of the time.

National power systems with high shares of wind farms need additional power production sources of conventional power plants accordingly. These conventional power plants must be able to start generating power soon after wind farm disconnections. In these cases hydroelectric power plants are feasible.

Voltage fluctuations in unified energy systems are mostly caused by uneven production and consumption of reactive power. The voltage at the nodes of the network depends on the balance of reactive power. It should be noted that asynchronous generators and synchronous generators, which are used in wind turbines, produce reactive power. They influence the voltage at the connection point of the network. The voltage at the output of wind turbines must be in the range  $\pm 10\%$  of its nominal value. The voltage level can be regulated by transformers equipped with On-Load Tap-Changers (OLTCs).

The power quality of electric energy includes the definition of the limits of flicker, harmonics and voltage variation. The presence of flicker, harmonics and voltage variation is regulated by European standard EN 50160. The limit of voltage drop is also determined on the basis of standard EN50160. According to a study of Russian and European technical documents, it can be concluded that there are no uniform requirements for connecting wind farms to grids. This can be explained by the diversity of wind power development in different countries: the share of wind farms in unified energy systems, types of wind turbines, etc. However, all technical documents have the same requirements concerning:

- utilization of wind turbines under specified conditions
- regulation of the power and speed of the rotor
- control of active and reactive power in certain ranges.

### 3.4 Control systems of wind turbines

In wind turbines, the kinetic energy of wind  $P_0$  is converted to electrical energy  $P_{el}$  (Figure 3.17). By using different kinds of control systems, an optimum power output can be produced in wind turbines, in a safe, reliable and profitable way. Generally, the control strategies of wind turbines aim at:

- maximizing energy production while keeping operations within the speed and load constraints of the turbine components
- preventing extreme loads
- providing acceptable power quality in grid connection
- ensuring safe turbine operation (Manwell et. al. 2009, 370).

The main regulated parameters of wind turbines from the grid connection point of view include:

- the generated electrical power output  $P_{el}$  to a grid
- the generated voltage  $U_1$  and frequency  $f_1$  to a grid.

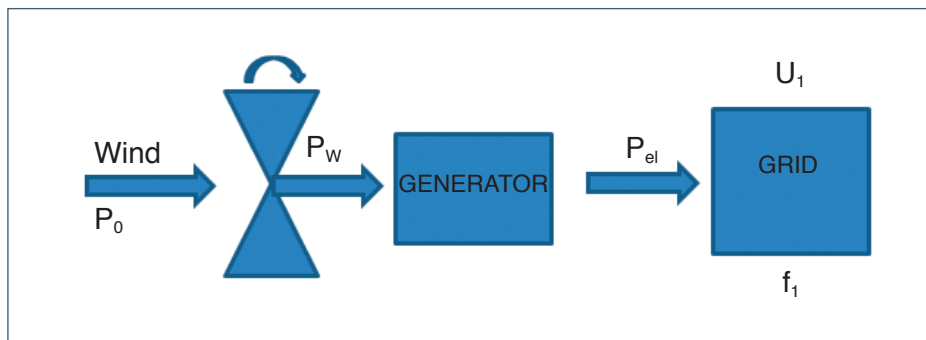

Figure 3.17. From kinetic energy of wind to electrical power of a grid.

Every wind turbine has a specific power curve of its own. In the power curve, the power output is presented in relation to the wind speed. An ideal power curve is presented in Figure 3.18. Range I consists of low wind speeds, and the turbine is below the rated turbine power. The turbine runs at maximum efficiency to extract all power. Range II is a transition range mainly concerned with keeping the rotor torque and noise low. Range III has high wind speeds, and the turbine works at a rated turbine power.

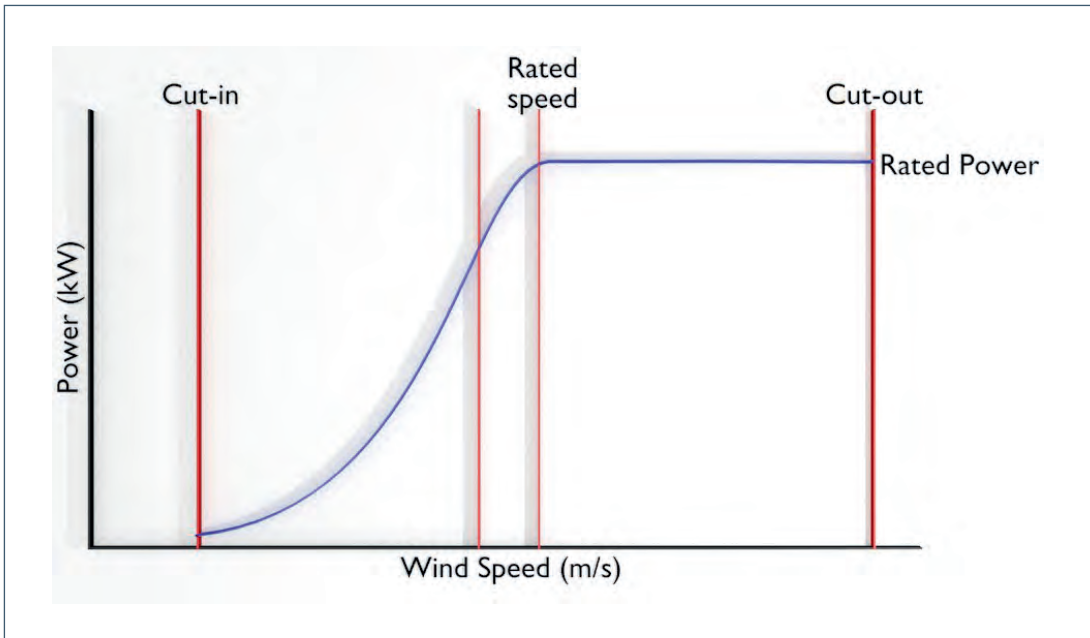

Figure 3.18. Power output of a wind turbine in relation to wind speed. Adapted from (National Instruments 2013)

Principally a wind turbine can be operated in two basic operation schemes:

- **In an isolated operation** (islanding) a wind turbine is not connected to a grid, but the turbine feeds connected consumers directly. Synchronous generators are often used for this kind of stand-alone operation.
- **In a grid operation**, a wind turbine is connected to a consumer grid. When the wind turbine is connected to a rigid combined grid, it is assumed that the output power of the turbine can be directly transferred to the grid.

The following drive-train systems are used in wind turbines:

- fixed speed asynchronous generator (ASG)
- 2-speed asynchronous generator (ASG)
- wound rotor induction (asynchronous) generator (WRIG)

- doubly-fed induction generator (DFIG)
- electrically excited synchronous generator (EESM)
- permanent magnet synchronous generator (PMSG).

Fixed-speed generators are earlier constructions of the 1980s while permanent magnet generator systems are the latest generations of the 2010s. In all new MW-class installations, the speeds of generators are controlled and different kinds of control technologies are utilized. The optimal operation point of a wind turbine should be achieved with different wind speeds. Control realizations vary due to the different drive train systems of wind turbines (Pyrhönen 2013).

### 3.4.1 Operation states of wind turbines

Most of the time, a wind turbine operates in some of its long-term, stationary operation states. There are four main stationary operation states of wind turbines (Figure 3.19):

- In the state **standstill** a wind turbine is not working.
- In the **ready for operation**, we have a readiness of the turbine, and wind speed and direction are measured.
- In the state **power production**, a wind turbine produces electricity into the network.
- A wind turbine may have a state called **freewheeling** when a rotor is rotating but not producing electricity in low winds, under cut-in speeds.

In starting or stopping, a wind turbine transits from one short-term operation state, a transitional state, to another operation state. There are six transitional operation states (Figure 3.19) in wind turbines:

- In the state **system check**, monitored components influencing variables and command variables are checked.
- In the **start-up**, rotor brakes are released, yaw and pitch control loops start working but there is no load yet.
- In the state **grid connection**, a wind turbine is connected to a grid. Generator control loops start working.
- In **grid disconnection**, generator control loops stop working and a wind turbine is disconnected from a network.
- In the state **shut-down**, the power output of a wind turbine is reduced and the turbine decelerated.
- In the state **emergency shutdown**, a rotor brake system is activated immediately (Heier 2006, pp. 353 – 363) (Manwell et. al. 2009, p. 360).

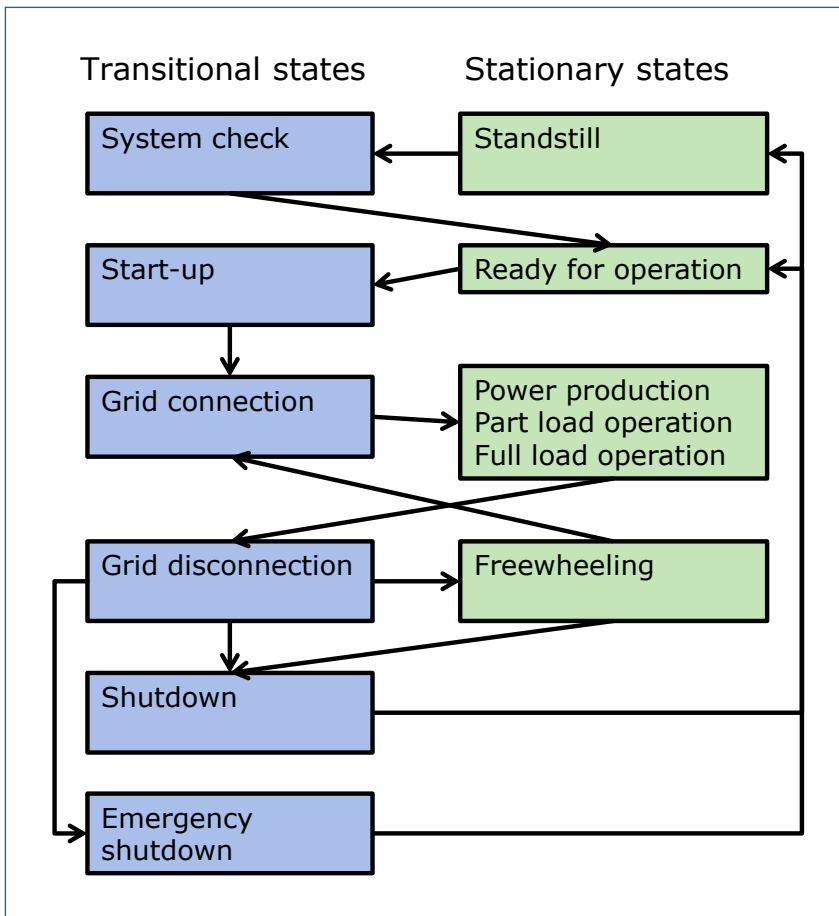

Figure 3.19. Stationary and transitional operation states of wind turbines (Manwell et.al. 2009, 376)

### 3.4.2 Measurement technology

In wind turbines themselves, several operational and maintenance variables and parameters must be measured:

- **speeds**, such as generator, wind, yaw rate, direction of rotation speeds
- **positions**, such as blade pitch, blade, yaw, wind direction positions
- **electrical variables and parameters**, such as grid power, current, power factor, voltage, grid frequency, ground faults, frequency converter operation
- **temperatures**, such as gearbox oil, hydraulic oil, gearbox bearing, generator bearing, generator winding, electronics temperatures
- **fluid characteristics**, such as hydraulic and pneumatic pressures, hydraulic oil levels, hydraulic oil flows
- **operation and maintenance parameters**, such as tower top acceleration, tower strain, shaft torque, gearbox vibration, blade root bending moment
- **environmental conditions**, such as turbine and sensor icing, humidity, lightning (Manwell et. al. 2009, p. 366).

The power output control of wind turbines is based on wind speed, wind direction, pitch angle, yaw position, rotor and generator speed measurements. Measurement devices of wind speed and direction are often called anemometers or wind gauges (Figure 3.20). The left hand side turning sensor, wind vane, is responsible for the measurement of wind direction, while the right-hand rotating sensor stands for wind speed.



Figure 3.20. Measurement sensors of wind direction and wind speed in a nacelle.

### 3.4.3 Control concepts of wind turbines

In the design requirements of wind turbines, it is stated that the control systems of wind turbines must cover the management of the following parameters:

- power
- rotor speed
- connection of the electric load
- start-up and shutdown procedures
- cable twist
- alignment to the wind.

Accordingly, protection systems must be activated in cases of:

- overspeed
- generator overload or fault
- excessive vibration
- abnormal cable twist due to nacelle rotation of yaw control (IEC 61400-1 2005, p. 46)

In commercial wind turbines, the most effective methods to regulate the power output of wind turbines are the regulation of the blade pitch and the speed of the rotor. The speed of the generator is dependent on the gearbox and the speed of the rotor. Principally, there are four basic control concepts, and the power curves using different control modes differ from each other (Figure 3.21):

- By using a **Fixed-Speed Fixed-Pitch (FS-FP) control concept**, there is rather low energy capture. The rated power can only be achieved by a very limited wind speed range of the power curve. In this concept, the turbine's generator is directly connected to a grid, and the generator speed is locked.
- A **Fixed-Speed Variable-Pitch (FS-VP) control concept** has optimal power efficiency below rated wind speeds and the turbine operates at a fixed pitch angle. Above rated wind speeds, the turbine continuously adjusts the pitch angle.
- A **Variable-Speed Fixed-Pitch (VS-FP) control concept** continuously adjusts the rotor speed relative to the wind speed by regulating the speed of the generator. This control mode assumes that the generator and drivetrain are free to rotate independently from the grid frequency. The rated power can only be achieved by a very limited wind speed range of the power curve.
- By applying a **Variable-Speed Variable-Pitch (VS-VP) control concept** below rated wind speeds, the maximum power output can be achieved. This maximum power output also remains at greater wind speeds. The power curve is optimal in all wind speed ranges (National Instruments 2013)

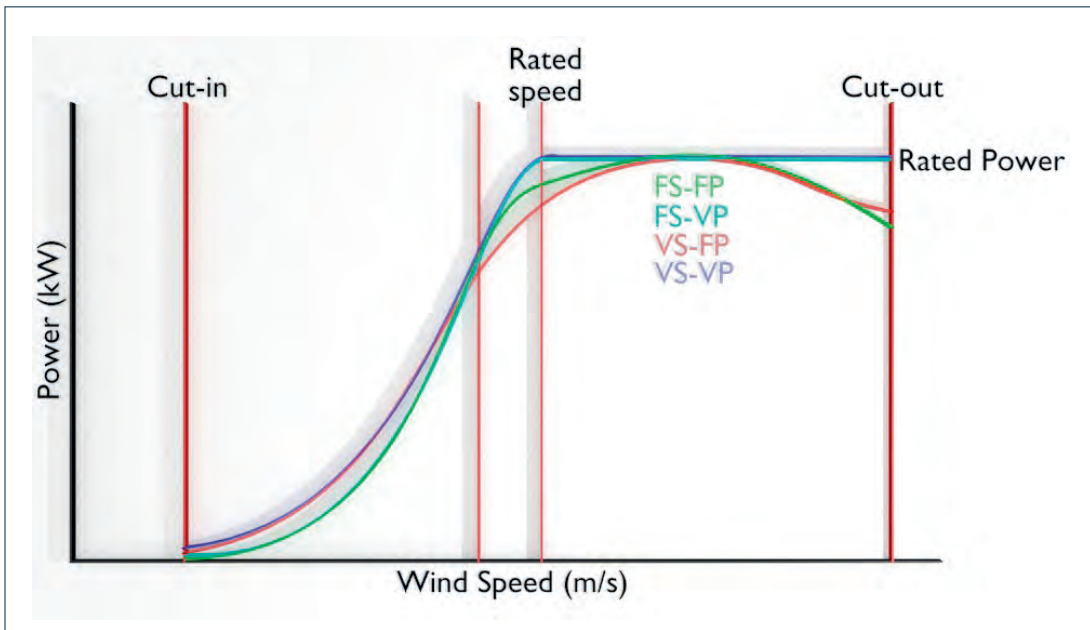

Figure 3.21. Power curves using four basic control concepts adopted from (National Instruments 2013).

The control concepts related to wind speeds can also be concluded in the following way:

- At low wind speeds, we aim at a constant tip-speed ratio: The generator torque is controlled and is adjusted according to the generator speed. The pitch angle is not controlled.
- Close to nominal speeds, we aim at a constant rotation speed: The generator torque is adjusted by a speed controller for smooth power.
- Above nominal wind speeds, we aim at a constant power output and speed: the generator torque and the rotation speed are kept constant. The turbine torque is controlled by the pitch (Manwell et. al. 2009, 371) (Pyrhönen, 2013) (Manwell et. al. 2009, 370 - 374)

#### 3.4.4 Yaw control

Winds should face the blades of a wind turbine in an upright direction. All HAWT's should be provided with an alignment system, a yaw system, for turning a rotor axis (a nacelle) when the wind direction changes. The rotor with blades runs either upwind or downwind, while wind turbines running upwind are very common. The yaw control system ensures that the rotor is oriented optimally at all times (Figure 3.22).



Figure 3.22 Power output control using an alignment to the wind, a yaw control.



The yaw system is provided with four electric drives which are driven all the time according to wind direction measurements (Figure 3.23). This positioning of the nacelle is controlled by a programmable logic controller (PLC) of the wind turbine.

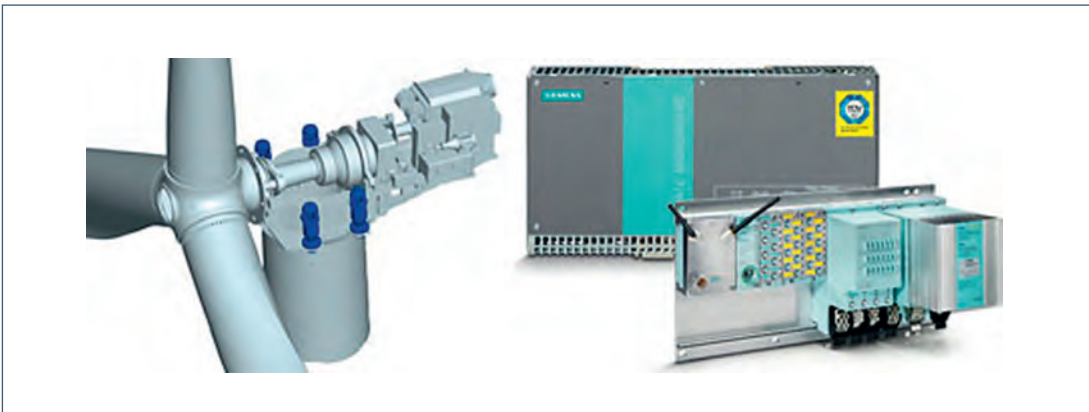

Figure 3.23. Electric drives of a yaw control system controlled by a PLC (Siemens 2013).

### 3.4.5 Pitch control

Principally, the angles of blades, the pitch, in a wind turbine can be passively stall-regulated, or actively pitch-regulated (Figure 3.24):

- In a **stall-regulated** scheme, when the wind speed approaches the value at which the generator reaches its nominal power, further torque development of the rotor must be inhibited. Thus the blades should stall to avoid damage. This stall-control scheme is mostly used in smaller wind turbines up to 1.5 MW.
- In a **pitch-regulated** scheme, the angles of blades are turned optimally related to the wind speed and direction using hydraulic or electromechanical actuators. Smaller pitch angles of blades are related to smaller power outputs, while bigger pitch angles lead to higher power outputs. In most modern wind turbines, the blades may be controlled separately. The pitch-regulated scheme has the optimal power curve (Figure 3.21).

Stall-regulated wind turbines passively regulate the power output, while pitch-controlled wind turbines try to keep the angle of wind attack and the blade as optimal as possible, all the time. This control scheme is used together with the generator speed control (Figure 3.25).

Power variations, and related grid reactions in low-power or heavily loaded grids, can be reduced using a remote monitoring system (SCADA) and the control system of a wind turbine. The scope of the VS-VP control concept is presented in Figure 3.25. This kind of arrangement is very common in medium-sized and high-output units. With this arrangement there is an impact on the wind turbine power output and the torque at the drivetrain, either by adjusting the blade pitch  $\beta$

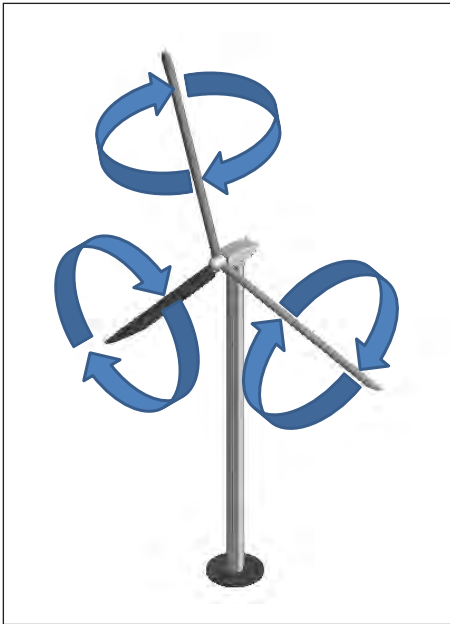

Figure 3.24 Power output control using the pitch control of a wind turbine.

or by influencing the generator torque and thus the turbine speed  $n$ . These systems thus have two independent intervention systems. This reduces operational demands on the pitch adjustment on one hand, and on the turbine, drivetrain and generator on the other.

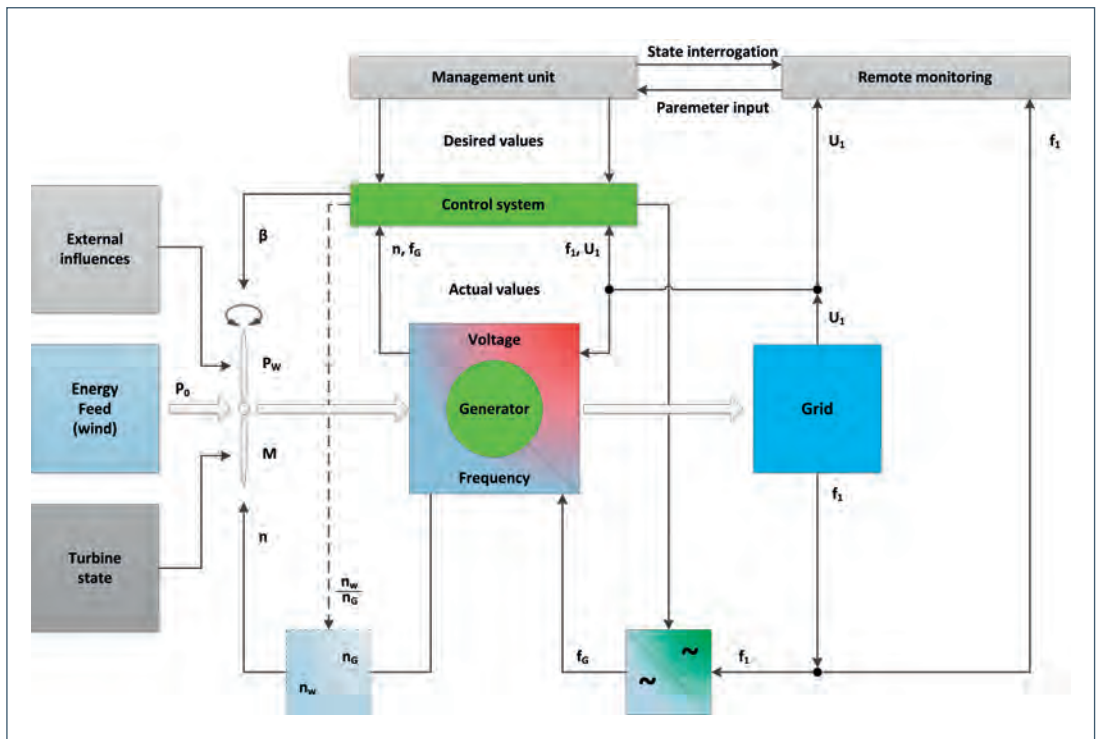

Figure 3.25. Control scope of a variable-speed variable-pitch (VS-VP) wind turbine applied from (Manwell et. al., 2009, p. 308).

### 3.4.6 Control system hardware

Principally there are three different control system categories in wind energy production (Figure 3.26):

- I Dynamic component controllers of different machines are often supplier-specific arrangements. These controllers take care of basic-level electromechanical or hydraulic component control. Their low-level arrangements may be related to pitch, yaw, generator and brake systems, for example.
- II Wind turbine control systems are responsible for operation states and the main control tasks in them, such as pitch, yaw, brake and grid connection control. Commercial programmable logic controllers (PLCs) are often used.
- III Wind farm control systems optimize the whole energy production of a wind farm. These wind farm control systems consist of commercial computer networks, and in this role are often called Supervisory Control And Data Acquisition (SCADA) systems.

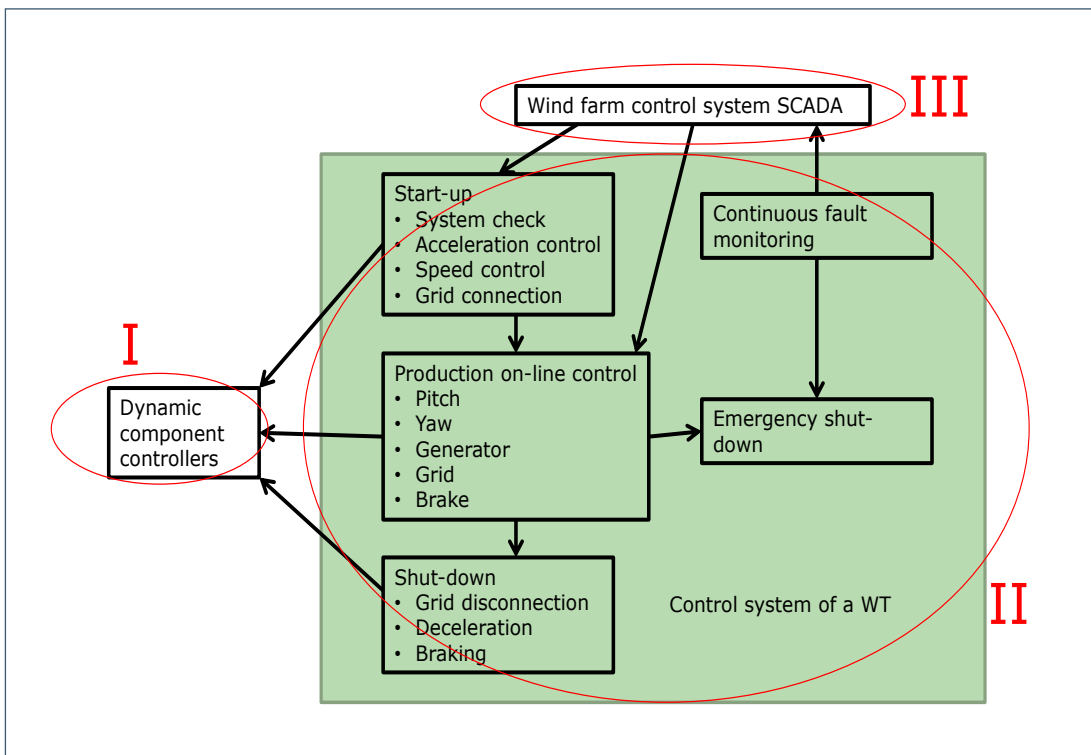

Figure 3.26 Roles of dynamic component controllers, wind turbine control systems and wind farm control systems in wind power production in general.

### 3.5 Literature references

ABB 2013. Wind Power Generators. Available through <http://www.abb.com/product/fi/9AAC100348.aspx> [Viewed 30.9.2013]

Bosch-Rexroth, Pitch control. Available through: [http://www.boschrexroth-us.com/country\\_units/america/united\\_states/sub\\_websites/brus\\_brh\\_i/en/industries\\_sm/wind\\_energy/hydraulic\\_control\\_technology/pitch\\_control\\_systems/index.jsp](http://www.boschrexroth-us.com/country_units/america/united_states/sub_websites/brus_brh_i/en/industries_sm/wind_energy/hydraulic_control_technology/pitch_control_systems/index.jsp). [Viewed 1.12.2013]

Danish wind industry association. 2003. Generators. Available through [http://www.motiva.fi/myllarin\\_tuulivoima/windpower%20web/en/tour/wtrb/syncgen.htm](http://www.motiva.fi/myllarin_tuulivoima/windpower%20web/en/tour/wtrb/syncgen.htm) [Viewed 30.9.2013]

Energiatollisuus ry. 2013. Tuulivoima. Available through: <http://energia.fi/energia-ja-ymparisto/energialahteet/tuulivoima> [Viewed 30.9.2013.]

Heir, S., Grid Integration of wind energy conversion systems, 2nd edition, 2006, Wiley.

Huhtinen, M. Korhonen, R. Pimiä, T. Urpalainen, S. Voimalaitostekniikka. 2008. Otava.

IEC 61400-1 2005. Wind turbines – Part 1: Design requirements, 3rd edition, IEC, Switzerland.

Intechopen, 2013. Available through [www.intechopen.com](http://www.intechopen.com). [Viewed 21.10.2013]

Kawady, T. A., Mnsour, N. M., Taalab, A-M. 2007. Available through: [http://cdn.intechopen.com/pdfs/10135/InTech-Wind\\_farm\\_protection\\_systems\\_state\\_of\\_the\\_art\\_and\\_challenges.pdf](http://cdn.intechopen.com/pdfs/10135/InTech-Wind_farm_protection_systems_state_of_the_art_and_challenges.pdf). [Viewed 21.10.2013]

Korpela, A. Tuulivoiman luonnontieteelliset perusteet, Tampereen teknillinen yliopisto, 2012

Manwell, J.F., McGowan, J.G., Rogers, A.L., Wind energy explained, Theory, design and application, 2nd edition, 2009, Wiley.

Mikkonen, A. Mitä tuulivoima maksaa? Tuulivoimalan investointi-, käyttö- kunnossapito- ja tuotanto kustannukset Suomessa, 2011.

Molina, M. G., Alvarez, M. G., Technical and regulatory exigencies for grid connection of wind generation. Available through [http://cdn.intechopen.com/pdfs/17118/InTech-Technical\\_and\\_regulatory\\_exigencies\\_for\\_grid\\_connection\\_of\\_wind\\_generation.pdf](http://cdn.intechopen.com/pdfs/17118/InTech-Technical_and_regulatory_exigencies_for_grid_connection_of_wind_generation.pdf). [Viewed 21.10.2013]

National Instruments 2013. Available through: <http://www.ni.com/white-paper/8189/en/>. [Viewed 13.9.2013]

Pyrhönen, O., Energy Conversion in wind turbines. Lecture slides, Lappeenranta University of Applied Sciences, 29.1.2013.

Päivinen, O. Tuulivoimalapystytys on kellosepäntytystä, 3T magazine, 30.9.2013.

Rajapakse A., Muthumuni D. and Perera N. Grid integration of renewable energy systems, 2006.

Siemens 2013. Intelligent yaw control. Available through: <http://www.automation.siemens.com/mcms/topics/en/wind-automation/automation-technology/yaw-control/pages/default.aspx> [Viewed 1.12.2013]

Suomen Tuulivoimayhdistys ry. 2013. Tuulivoimatietoa-sivusto. Available through: <http://www.tuulivoimatieto.fi/rakenne> [Viewed 30.9.2013.]

Vaasa Energy Institute. 2013. Turbiinin valinta. Available through: [http://wind.vei.fi/public/index.php?cmd=smarty&id=19\\_lfi&PHPSESSID=ffe56d7666ebbed82d9e7f38354e6e4b](http://wind.vei.fi/public/index.php?cmd=smarty&id=19_lfi&PHPSESSID=ffe56d7666ebbed82d9e7f38354e6e4b) [Viewed 30.9.2013.]

## 4 MAINTENANCE OF WIND TURBINES

Wind turbine maintenance aims at maximizing the length, reliability and productivity of the life cycles of wind turbines and farms. Maintenance activities also ensure steady and safe production conditions. In this chapter, the broad concept of maintenance is primarily limited to maintenance of devices.



Figure 4.1. Two Siemens service engineers working in the nacelle of a wind turbine at Sweden's Lillgrund offshore wind farm (Siemens Press Pictures 2008)

The typical maintenance costs of a wind turbine comprise approximately 20 – 25% of its total costs. Properly planned maintenance decreases the total costs of wind farms and turbines and improves productivity. The development of wind turbine maintenance during the last decade has steadily decreased the costs related to a produced unit of energy (International Renewable Energy Agency 2012, 25).

## 4.1 Basic concepts of maintenance

The concept of maintenance has changed in the last few decades. Originally, it just meant repairing damaged parts. Nowadays, it is seen as asset management. The precise definitions of maintenance can be found in European-Finnish standard SFS-EN13306. The term ‘availability’ is also defined in Finnish standard PSK6201 (Figure 4.2).

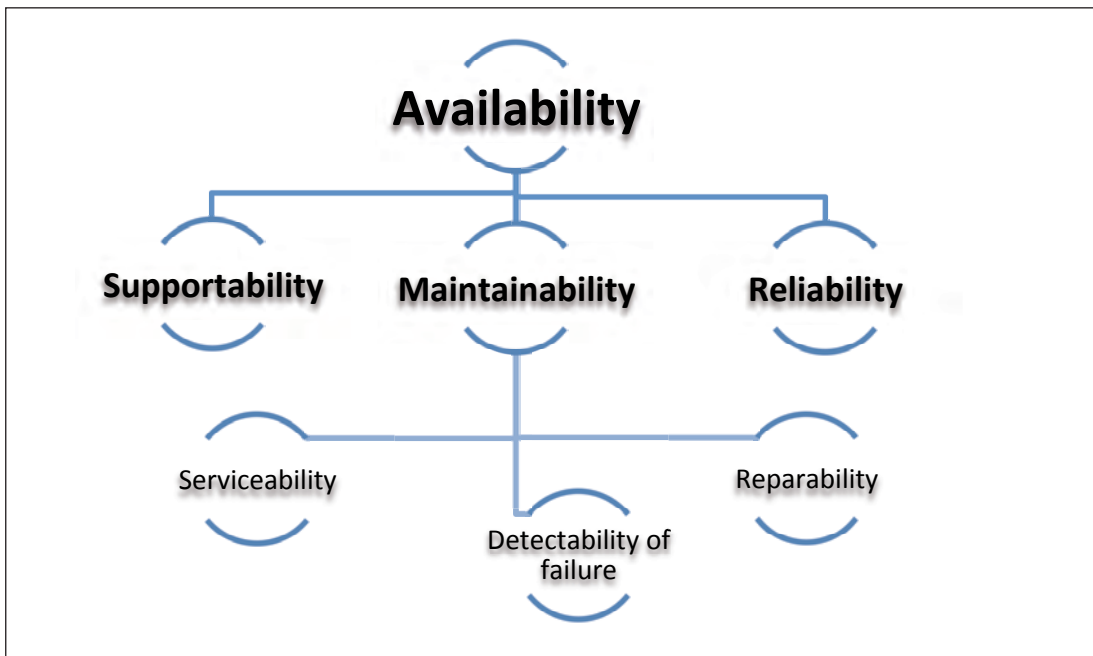

Figure 4.2. Basic terms of maintenance (Kunnossapitoyhdistys 2011, 36-37)

**Availability** defines the time in which equipment is in full operational capacity, carrying out the function which it has been set to do. In case of wind turbines, this availability means the time when it produces or is ready to produce electricity. Availability can be rated by calculating uptime per total time.

$$availability = \frac{uptime}{total\ time} = \frac{uptime}{uptime + downtime}$$

Uptime includes production time, except for the time when the wind turbine does not produce electricity, if this is caused by poor wind conditions. Downtime includes only the interruption time of production caused by failures (Lanthier 2011).

**Reliability** means the probability of a device being capable of performing its set task. In case of wind turbines, this means the probability of being able to produce electricity. Reliability is generally measured using two different indicators – mean time between failure and failure rate. Mean time between failure (MTBF) means the total time in service in relation to the number of failures. Failure rate indicates the number of failures per total time in service (Lanthier 2011).

**Maintainability** characterizes an item's capacity to be kept in operational condition or to be retrieved to operating readiness when maintenance is carried out in specified conditions and time, using required methods and resources. In case of wind turbines, the weather conditions should be good, the down time as short as possible and the spare parts approved by the manufacturer. The factors affecting maintainability are the detectability of failures, serviceability and reparability.

**Detectability** of failures essentially pertains to condition monitoring. In case of wind turbines, it indicates remote monitoring of production and control systems. If the operation of a turbine differs from usual conditions, the reasons for the abnormal phenomena should be investigated.

**Serviceability** includes the availability of the spare parts and the accessibility on-site. Both of these could be very challenging in case of wind turbines, especially in wintertime or in offshore power plants.

The most important factors affecting to reparability of wind turbines are the availability and validity of documentation concerning devices, the maintenance manuals of manufacturers and the availability of required special tools. Accessibility, already mentioned above, also adds challenges to reparability. Occupational safety plays an important role in the reparability of wind turbines, because maintenance operations include lifting and working in high places. Lifting often requires special cranes and tools, as well as suitable weather conditions. Furthermore, it is essential, after



Figure 4.3. Demanding lifting operations with special equipment (Siemens Press Picture 2009)



maintenance operations, to test the arrangements together with the operation personnel (Kunnossapitoyhdistys 2011, 37).

**Supportability** describes the ability of a maintenance organization to perform the required maintenance tasks in a safe and efficient way and in a short time. Supportability does not measure the actual duration of maintenance operations but rather everything else needed to perform it.

The maintenance organizations at wind farms differ significantly from the organizations behind conventional high-power power plants. The maintenance organization of a wind farm usually has a limited number of staff with extensive expertise. Therefore, it is usual to outsource maintenance operations. Maintenance organizations must be able to maintain and organize computerized maintenance management systems. With correctly maintained maintenance management systems, it is easier to develop best practices, update documentation and working instructions. These maintenance teams need qualified professionals to manage the specific circumstances of wind turbines. Working as high as 100 meters requires stability and the calm nerves of maintenance specialists (Figure 4.4) (Kunnossapitoyhdistys 2011, 38-39).



Figure 4.4 Well-planned maintenance operations required on land and at sea (Siemens Press Pictures 2013)

## 4.2 Operation and maintenance costs

In modern wind power systems, the fixed and variable costs of operation and maintenance (O&M) make up 20% to 25% of the total cost of energy. The actual costs of O&M are seldom available from commissioned projects and historical data might be outdated, due to the dramatic development of wind turbine technology. It has been found that the averages of annual O&M costs have significantly decreased since 1980. In the United States, the total costs of O&M, including fixed and variable costs, have declined from around \$33/MWh in the 1980s to around \$10/MWh in the 2000s. In Europe, O&M tends to have a slightly higher cost structure than in the USA. Perhaps lower costs in the USA come from larger-scale markets and longer experience of wind power systems.

Operation and maintenance costs are not evenly distributed over time. As the wind power systems age, the probability of failures increases and these failures tend to occur outside the manufacturer's warranty period. O&M costs also tend to differ a lot between projects.

O&M costs for offshore wind farms are significantly higher than for onshore wind farms due to the higher costs involved in accessing and conducting maintenance on the wind turbines. The higher expected failure rate for some components, caused by the harsh marine environment also increases maintenance costs. Overall, the operations and maintenance cost range for offshore wind farms is expected to be between \$27/MWh and \$54/MWh. In future, O&M costs will remain a key challenge when speaking about the economics of offshore wind utilization (International Renewable Energy Agency 2012, 25).

## 4.3 Maintenance items of wind turbines

A maintenance item is any part, component, device, subsystem, functional unit, equipment or system which can be viewed separately. It may consist of physical parts, software or both. Sometimes it also includes personnel. In this study, the maintenance items of wind power are divided into mechanical and electrical categories (Kunnossapitoyhdistys 2011, 34).

In the maintenance of wind turbines, it has been observed that the main contributors to failure rates are the electrical, hydraulic and control systems and the sensors (Figure 4.5). On the other hand, the large mechanical components are responsible for the longest downtime per failure. Also, due to the location of Finland, the acquisition of spare parts may generate additional downtime (Besnard 2009, 37).

According to Anders Stenberg's Master's thesis written for the VTT (Technical Research Centre of Finland), the longest downtime comes from the gears of the wind turbines. The reason for this is the challenging maintenance operations. The gearbox cannot be maintained up in the nacelle but must be brought down. In Finland this kind of lifting work is problematic, due to lack of sufficiently effective cranes (Stenberg 2010, 42).



Figure 4.5. Complicated maintenance work, high in the nacelle. (Siemens Press Pictures 2010)

### 4.3.1 Electrical systems

In terms of numbers, the most failures come from electrical systems. Nevertheless, these failures are minor, such as blown fuses and wires or manufacturing defects of components. The repair of faulty components is usually very quick, because the components are cheap and small. Because of this, storage and transportation of the components are also easy and inexpensive (Stenberg 2010, 44).

### 4.3.2 Hydraulic systems

Hydraulic systems cause failures relatively often. The most common faulty components are hydraulic pumps and tubes. Maintenance of these components is needed in almost every failure case. At the end of the hydraulic system's life cycle, a number of failures increase significantly. Many failures occur concerning pitch control and brake systems (Stenberg 2010, 46).

The major problems in pitch control systems are caused by hydraulic control systems, but the bearings of motors and measurement instruments also cause downtime. Even minor problems must be considered and maintained rapidly, because the pitch control system is a critical component for the safe operation of a wind turbine (Stenberg 2010, 44).

### 4.3.3 Blades

The blades of a wind turbine are often sold as maintenance-free, even though they need maintenance and especially inspection just like any other device. Due to northern conditions, regular inspections are extremely important for the long-term operation of the blades.

Water and moisture inside the structure of the blades must be removed before winter. The moisture that remains inside the structures expands and causes small cracks. Damage caused by cracking starts to spread leading to breakdown of the blades. The simplest way to prevent water from remaining is to keep the drain holes in the tips of the blades open, so that centrifugal forces push the moisture away while the blades are rotating.

Even though the blades are protected from lightning, they must be inspected after every lightning strike. Small errors in the placement of lightning conductors during the construction phase may lead to a case when lightning takes a shortcut through a bend of the conductor. Thus the conductor melts and causes a huge failure in the structure of the blade. Internal structural failures may not be visible outside. Visible damages caused by lightning strikes may be very small, but the inner structures may be damaged significantly. The energy released in the lightning strike vaporizes the humidity inside the blade. If the drain hole is shut, vaporized water may completely destroy the tip of the blade.

When wind turbines rotate, water drops and pollutants from the air cause mechanical wear on the coating of the blades. If wind turbines are located close to heavily polluting industrial sites, air pollutants may corrode the coating and weaken the structure of the blades during a very short period (Karkkolainen 2013).

### 4.3.4 Control systems

The failures of control systems and measurement sensors are usually quickly fixed, because maintenance actions normally consist of replacing components. With older wind turbines, waiting for suitable components may lead to long downtimes. In the beginning of the life cycle of control systems, maintenance operations usually include fast replacement of electronic circuits. Later in the life cycle, failures are usually caused by breakdowns of the process computers which leads to significantly longer downtimes (Stenberg 2010, 48).

## 4.4 Failures

Failures can be classified into disturbances and damage. The consequences of disturbances and damage cause production losses and an immediate need for repair. In disturbance situations, production capacity is principally restored by cleaning, adjusting or resetting components. Nonetheless, damage always requires corrective maintenance (Kunnossapitoyhdistys 2011, 34).

An example of disturbances could be the excessively high temperature of an electrical motor caused by the clogged air filter of a fan in the nacelle. In this case, failure is easily repaired by cleaning or installing a new filter. Damage could be caused, for example, by strong stray currents, heading to earth from a generator through a bearing. This can cause significant damage to bearings. Damaged bearings may cause vibrations or excessive heat, damaging the entire generator. This type of a damage usually requires taking the generator down from the nacelle.

VTT Technical Research Centre of Finland has been gathering the failure statistics of wind turbines located in Finland since 1996. Anders Stenberg analyzed these failure statistics 1996 - 2008 in his Master's thesis. Stenberg's study consists of data gathered from 72 different wind turbines. In the following tables, Stenberg's statistics are organized according to the percentage of downtime per component caused by failures and the percentage of failures per different components. According to Stenberg, it is not the quantity but the quality of failures that causes long downtimes in production.

**Table 4.1 Percentages of downtime in wind turbine components**

Component	Downtime per component
Gearbox	18 %
Hydraulic system	15 %
Brake system	10 %
Generator	9 %
Sensors	7 %
Rotor, including axel and blades	7 %
Electrical system	6 %
Pitch control system	4 %
Yaw system	4 %
Control system	4 %
Structure	4 %
Grid connection	4 %
Heating	3 %
Unknown	3 %
Other	1 %

**Table 4.2 Percentages of failures in wind turbine components**

<b>Component</b>	<b>Failures per component</b>
Hydraulic system	21 %
Electrical system	11 %
Sensors	11 %
Generator	8 %
Pitch control system	8 %
Gearbox	7 %
Control system	7 %
Brake system	5 %
Yaw system	5 %
Grid connection	5 %
Heating	4 %
Rotor, including axel and blades	3 %
Other	3 %
Unknown	2 %
Structure	1 %

Northern conditions pose several challenges for the design and maintenance of wind turbines. The main problems are caused by cold weather. Icing, snow and changes in material properties may also cause serious problems. One of the biggest problems in northern conditions is icing. Blades can accumulate two kinds of ice. Transparent glaze forms sheets of ice over large surfaces. Rime ice degrades turbine performance by disturbing sensors, for example. It may also cause rotor imbalance and malfunctions of aerodynamic brakes. Icing is also a danger for maintenance personnel.

Icing problems could be reduced with special blade coatings, heating systems and electrical or pneumatic devices used to remove accumulated ice. Blade heating may be based on a heating element installed on the surface of the blade. The conduction of electricity warms up the element and melts the ice on the surface. Unfortunately, the heating elements have modest durability. Air pollutants and moisture erode the coating of the heating elements very quickly. Hot air blown into blades keeps the blade warm thus preventing the accumulation of ice on the surface. The air blown from a nacelle effectively removes the moisture accumulated in the structure which improves the durability of the blade in northern conditions.

Cold weather may cause changes in material properties. Frost reduces the flexibility of rubber seals which could cause leaks. Frost also reduces clearances and fracture strengths. Problems may occur also with lubricating, because cold weather increases the viscosity of lubricating oils. Changes in material properties may cause problems in every part of a wind turbine. Material problems can be reduced with heaters, special materials and de-rated strengths because of the brittleness (Manwell et. al. 2010, 418 - 419) (Finnish Wind Atlas s.a.).

**Table 4.3**

**Things to pay attention to in wind turbine maintenance in northern climates**

- Possible limitations of low temperature operation by the manufacturer
- Possible limitations of operation during icing
- Maintenance scheduling for harsh conditions
- Wintertime site access limitations
- Possible need for additional monitoring systems, such as web cams

(International Energy Agency IEA Wind 2011, 31)

In addition, in Nordic countries located near the Arctic Circle the length of the day during winter-time complicates maintenance operations. The operating time in daylight can be just a few hours. On the other hand, during the summer working days may be long.

## **4.5 Preventive maintenance and condition monitoring**

Maintenance of wind turbines is based on preventive maintenance. Preventive maintenance aims at shorter downtimes on the basis of detecting starting failures (Kunnossapitoyhdistys 2011, 72).

Preventive maintenance can be divided into performance monitoring, scheduled maintenance and condition monitoring. Monitoring and maintenance are carried out by professional operation and maintenance teams. Inspections and maintenance tasks are documented.

Performance monitoring is continuously performed by monitoring and maintaining. Scheduled maintenance is planned in advance as a definite part of operations. In condition monitoring, the statuses of items are monitored based on measurements. The operations in condition monitoring are more extensive than in performance monitoring and more continuous and longer-term than in scheduled maintenance (Kunnossapitoyhdistys 2011, 50).

**Table 4.4 Condition monitoring items of wind turbines (Verbrugge 2003, 11)**

<b>Monitoring techniques</b>	<b>Remote</b>	<b>On site</b>
Vibration analysis	x	x
Oil analysis	x	x
Thermography		x
Acoustic measurements		x
Visual inspection		x
Performance monitoring	x	
Self-diagnostic sensor	x	

Condition monitoring is based on remote and on site measurements (Table 4.4). Bearings, gear-boxes and electric motors can be monitored using vibration analyses. Varying operating conditions set challenges for these analyses. For example, varying wind speeds cause varying loads on constructions. This affects the total vibration of the tower and nacelle. Due to fluctuations in the loads caused by winds, it is challenging to set alarm limits and analyze vibration statistics. In addition, the analysis of vibration statistics requires a lot of expertise (Tranter 2013).

Performance monitoring of wind turbines is largely based on monitoring relationships between the variables power, wind velocity, rotor speed and blade angle. Large deviations from predetermined values set off alarms (Verbruggen 2003, 13).

The control systems and diagnostics of wind turbines have become more and more sophisticated. Nevertheless, the level detection and comparison of signals are still an important part of condition monitoring. According to T.W. Verbruggen's study 'Wind Turbine Operation & Maintenance based on Condition Monitoring WT-Ω', modern condition monitoring is based on the use of parameter estimation rather than trend analyses.

**Oil analyses** are used for monitoring lubricating ability and detecting the particulates of gear oil used in wind turbines. The functionality monitoring of gear oils contributes to the efficient operation of gearboxes and prevent failures. Particle filtration, used with an oil analysis, can significantly improve the life cycle of lubrication oils (Laine 2013).

**Thermography** which is widely used in condition monitoring in industry, is also a good tool for wind turbines. Thermography can be used to examine bearings causing vibrating alarms in more details. Maintenance actions or corrections of alarm limits may be needed. Based on thermographical inspections, the ventilation of the nacelle can be increased and thus the life cycle of electrical systems increased. In northern conditions, seasonal changes in temperature complicate the analyses of thermography.

**Acoustic measurements** are performed during installations and in the first start-up of a wind turbine. These measurements reveal noise in the neighboring locations of wind turbines.

**Machine current analyses** (MCSA) can be carried out to monitor electrical machines and are used for detecting unusual electrical phenomena. In the maintenance monitoring of wind turbines, it is possible to use discharge measurements and velocity measurements for switches, for example.

**Visual inspections** of wind turbines are carried out during every inspection, maintenance or other visit (Figure 4.6). It should be noted that, during maintenance visits, all components should be visually inspected, not only those which were the reasons for the visit. In less accessible places, like in offshore wind farms, visual inspections should be performed with surveillance cameras.





Figure 4.6. Maintenance team inspecting a rotor blade with the help of a lift (Courtesy of LM Wind Power, lmwind-power.com s.a.).

Maintenance programs are a very important part of maintenance management at wind farms. The maintenance program includes information on the maintenance tasks, timing and maintenance organization, maintenance logistics and acquisition of the spare parts (Besnard 2009, 39).

In Finland, the Federation of Finnish Financial Services has given its own instructions for loss prevention of wind turbines which also includes guidelines for maintenance. According to these instructions, the inspections for the installations of wind turbines must be done in accordance with manufacturer's maintenance programs. The maintenance programs must include operations regarding performance monitoring, periodic inspections and maintenance works. The inspection must be performed by the manufacturer of the wind turbine or by some other competent maintenance engineer, and must be documented (Federation of Finnish Financial Services 2013, 3).

#### **4.6 Corrective maintenance on site and in remote operation**

Corrective maintenance is performed after a detected fault. The detected fault is diagnosed and recognized. After localization of the fault, the item is repaired (temporary) and restored (Kunnosapitoyhdistys 2011, 49).

The management of wind turbine maintenance is based on preventive maintenance which should minimize production losses. Sudden interruptions in production coming from failures may also cause long fault chains to other devices in wind turbines. Damage to multiple devices easily causes long downtimes. The length of downtime depends on the availability of spare parts, the difficulty of maintenance work and eventual lifting.

Efforts are made to reduce corrective maintenance actions, because they almost always cause unplanned interruptions in production. The extent of the failure cannot be found until an on-site inspection is carried out which results in delays in the acquisition of spare parts. In addition, possible lifting work requires good conditions. In Finland, there are only few cranes with sufficient capacity for the required lift height and weight of wind turbines. Corrective maintenance operations for blades are given in the Table 4.5.

**Table 4.5 Corrective maintenance operations for blades (Gurvits, 2013)**

Corrective maintenance operations for blades
• Cleaning and coating
• Surface repairing
• Structural repairing
• Opening of congested drain holes
• Take-down
• Blade replacement

Wind turbine constructions play a considerable role in the implementation of maintenance actions. In some models it is possible to change the bearings of gears without bringing them down from the nacelle. In other older models it is necessary to bring the nacelle down even for minor maintenance work. The types of failures and components also affect maintenance actions. For example, changing gear oil is much easier to do than fixing a faulty main axis.

The maintenance of large faulty components such as a gearbox or generator often requires taking the components down during the maintenance operations. Large wind farms usually have a few spare parts in stock which can be immediately installed to reduce downtime, so there is more time to maintain faulty components and lifting work can be done at the same time.

Wind turbine maintenance work can hardly be carried out remotely. Instead measuring data acquisition using condition monitoring sensors connected to control systems can be monitored remotely (Figure 4.7). This measurement data serves as the basis for on-site inspections and the decision-making of production stops.

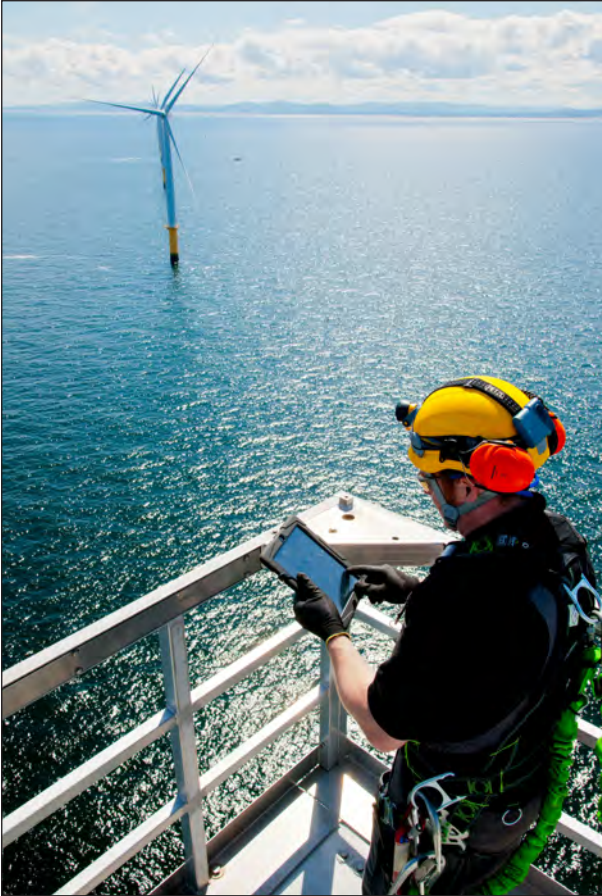

Figure 4.7 Remote tools for more efficient, safer and less time-consuming condition monitoring (Siemens Press Pictures 2013).

## 4.7 Literature references

Besnard, F. 2009. On Optimal Maintenance Management for Wind Power Systems. Available: <http://kth.diva-portal.org/smash/record.jsf?pid=diva2:282226> [Viewed 24.3.2013]

Federation of Finnish Financial Services. 2013. Tuulivoimalan vahingontorjunta. Available: [http://www.fkl.fi/materiaalipankki/ohjeet/Dokumentit/Tuulivoimala\\_2013.pdf](http://www.fkl.fi/materiaalipankki/ohjeet/Dokumentit/Tuulivoimala_2013.pdf) [Viewed 13.9.2013]

Finnish National Board of education. s.a. Kunnossapitotekniikan oppikirja. Perusteet. Available: <http://www03.edu.fi/oppimateriaalit/kunnossapito/perusteet.html>. [Viewed 3.4.2013]

Finnish Wind Atlas. 2013. Icing Atlas. Available: <http://www.tuuliatlas.fi/icingatlas/index.html>. [Viewed:1.4.2013]

Gurvits, F. s.a. Lapojen kunnossapito off-shore olosuhteissa. Available: <http://www.prizz.fi/asiakaskuvat/3DWS%20Merituulivoima%20Pori%2024042013.pdf>. [Viewed 4.9.2013]

International Energy Agency IEA Wind. 2011. 13 Wind energy projects in cold climates. Available: [http://www.ieawind.org/index\\_page\\_postings/June%207%20posts/task%2019%20cold\\_climate\\_%20rp\\_approved05.12.pdf](http://www.ieawind.org/index_page_postings/June%207%20posts/task%2019%20cold_climate_%20rp_approved05.12.pdf). [Viewed 13.9.2013]

International Renewable Energy Agency IRENA. 2012. Renewable Energy Technologies: Costs Analysis Series. Wind Power. Available: [http://www.irena.org/DocumentDownloads/Publications/RE\\_Technologies\\_Cost\\_Analysis-WIND\\_POWER.pdf](http://www.irena.org/DocumentDownloads/Publications/RE_Technologies_Cost_Analysis-WIND_POWER.pdf). [Viewed 3.9.2013]

Karkkolainen, V. Bladefence Ltd. Tuulivoimaloiden lapojen huolto. Presentation 18.4.2013. Tampere: Teolliset palvelut –fair

Kunnossapitoyhdistys ry. Kunnossapito. Kunnossapidon julkaisusarja n:o 10. 4. painoksen lisäpainos. Helsinki 2011.

Laine, J. 2013. Material of “Kunnossapidon tietojärjestelmät” –course. Kymenlaakso University of Applied Sciences.

Lanthier, P. 2011 Understanding the Difference Between Reliability and Availability. Available: [http://reliabilityweb.com/index.php/maintenance\\_tips/understanding\\_the\\_difference\\_between\\_reliability\\_and\\_availability/](http://reliabilityweb.com/index.php/maintenance_tips/understanding_the_difference_between_reliability_and_availability/). [Viewed 2.9.2013]

LM Wind Power. 2013. Image archive. Available: <http://lmw-mediaportal.digizuite.dk/>. [Viewed 13.9.2013]

Manwell, McGowan, Rogers. Wind Energy explained. Second edition. Wiley 2010.

Stenberg, A. 2010. Analys av vindkraftsstatistik i Finland. Available: <http://www.vtt.fi/files/projects/windenergystatistics/diplomarbete.pdf>. [Viewed: 2.4.2013]

Tranter, J. Vibration Analysis of Wind Turbines. Available: [http://reliabilityweb.com/index.php/articles/vibration\\_analysis\\_of\\_wind\\_turbines/](http://reliabilityweb.com/index.php/articles/vibration_analysis_of_wind_turbines/). [Viewed 3.5.2013]

Verbruggen, T.W. 2003. Wind Turbine Operation & Maintenance based on Condition Monitoring WT-Ω Final report–pdf. Available: <ftp://ecm.nl/pub/www/library/report/2003/c03047.pdf>. [Viewed: 24.3.2013]

Siemens AG. 2013. Press Pictures. Available: <http://www.siemens.com/press/en/presspicture/>. [Viewed 13.9.2013]

## 5 LAWS AND REGULATIONS

Finland ratified the UN Framework Convention on Climate Change (UNFCCC) in 1994 and the Kyoto Protocol in 2002 together with other EU member states. In terms of global climate policy, Finland acts as part of the European Union. This means that national preparation and implementation are largely governed by climate and energy policy targets and measures agreed within the EU (UNFCCC).

Finland has a renewable energy program and is aiming for a target of 38% of its final energy consumption from renewable sources by 2020. Construction of wind power will be expedited by improving planning and permit procedures and, consequently, the granting of permits. The production target for 2025 is set at approximately 9 TWh. The target for 2020 is 6 TWh. This would mean the construction of approximately 700 new turbines (National Climate and Energy Strategy 2013 p. 7, 33).

### 5.1 Wind power in Finland

The energy produced by wind power in Finland in 2012 was approximately 0.5 TWh. There were about 160 wind turbine generators in operation in Finland at the end of 2012.

Achieving the current objective for wind power requires the removal of non-financial obstacles to the construction of wind power. Determined efforts to remove obstacles to investment in wind power will be continued. The challenges of land use and land-use planning related to the construction of wind power could be influenced by promoting the construction of wind power in larger wind farms, instead of individual turbines or small groups of wind turbines.

There are also obstacles to wind power construction arising from possible disturbances in the operation of surveillance radars. The solution to removing these obstacles is under development and there are suggestions of special compensation for the radar operators.

Simultaneously, means of promoting the concentration of wind power construction in larger clusters will be investigated. This links directly to the plans for promoting large scale offshore wind power with significant state subsidies during the building phase.

### 5.1.1 Feed-in tariff

In Finland, electricity from renewable energy sources is mainly promoted through a premium feed-in tariff. The Act on Production Subsidy for Electricity Produced from Renewable Energy Sources lays down provisions on a feed-in tariff system for which power plants fuelled by wind, biogas, forest chips and wood-based fuels meeting the prescribed preconditions could be approved. From 2010, feed-in tariffs were in place in Austria, Cyprus, the Czech Republic, Estonia, Finland, France, Germany, Hungary, Ireland, Latvia, Lithuania, Luxembourg, the Netherlands, Portugal, Slovakia and Switzerland (The Act on Production Subsidy for Electricity Produced from Renewable Energy Sources. 2011).

The electricity from wind turbines will receive a feed-in tariff on top of the wholesale electricity price for a period of 12 years. The wind turbine owners thus get a fixed price for their electricity. The price is €83.5 per MWh. Wind energy plants will also be eligible for an increased target price of €105.3 per MWh until the end of 2015. Feed-in tariffs will be available only until the total capacity accepted in the tariff reaches a maximum level. This maximum is set at 2,500 MVA (**Laki** uusiutuville energialähteillä tuotetun sähkön tuotantotuesta. 2010).

In the feed-in tariff system, an electricity producer whose power plant is approved in the system will receive a subsidy (feed-in tariff) for a maximum of 12 years. The subsidy varies on the basis of the three-month electricity market price or the market price of emission allowances (Energy Market Authority. Table of the summary of the production subsidy scheme).

The producer is paid a feed-in tariff, which is the difference between the target price and the spot market price (last 3 months' average) in accordance with the amount of electricity produced in a wind power plant. The Energy Market Authority approves power plants for the feed-in tariff system, pays the feed-in tariff upon application, and manages other official tasks in the feed-in tariff system (Energy Market Authority. Table of the summary of the production subsidy scheme).

## 5.2 Wind energy regulation

Large-scale wind power construction is quite a new phenomenon in Finland. There has not been a wind energy-specific regulation concerning the construction of wind turbine or the zoning of wind farm locations. The general construction regulation applies to wind power. In some cases the

regulations are open to various interpretations, and in the worst cases are even unclear. This has increased the economic risk in planning new wind power plants.

The government has shown signs of support for wind-energy development and, within the last few years, there has been an improvement in the legislative situation. In 2011, the wind power zoning regulations took effect easing the building permit application process. The Ministry of Environment is also currently updating its instructions regarding wind energy construction permits and planning. Traffic authorities have issued new mitigating rules concerning wind power plants near roads and air traffic routes. Some open issues remain, but it is quite clear that more specific rules and regulations will appear in near future, which will alleviate and harmonize the legal process linked to wind power construction. Both society and the wind power industry will benefit from a transparent and simple application process.

### **5.2.1 Placement and zoning of wind power plants**

The placement plans and building permit procedure for wind power plant construction follows the same line as construction in general. The general arrangement for land use planning has several levels, and detailed regulations are spawned from higher-level plans. These levels are national, regional and local land use planning.

Finland's Environmental Administration develops and controls land use planning and construction throughout Finland. The most important legislation controlling land use, spatial planning and construction in Finland is contained in the Land Use and Building Act (Land Use and Building Act. 2003).

The National Building Code contains regulations and guidelines that complement the legislation in the Land Use and Building Act. The building regulations must be followed, but building guidelines are not obligatory, and other solutions may be used in construction as long as all the compulsory regulations are observed (Land Use and Building Act. 2003).

The regional land use plan transfers national and regional land use goals to the local level. Finland's land use planning system, as defined in the Land Use and Building Act, gives municipalities a high degree of autonomy in local land use planning. Regional land use plans are drafted and approved by the 19 regional councils, which are made up of representatives of the municipalities. Regional plans and local master plans indicate the land areas for utilizing the wind power. Local detailed plans follow the guidelines set in the master plans (Land Use and Building Act. 2003).

Land use plans favor wind farms instead of single wind turbines. By default wind power plant building sites are allocated far from permanent housing zones or recreation areas. If a prospective area for a wind power plant is nearby an area sensitive to nature (landscape, rare plant life, preserved animal species or areas listed in Natura 2000), the zoning procedure must follow the legislation concerning the diversity and preservation of nature (Natura 2000. Nature conservation areas in Finland).

## 5.2.2 Building permits

The permits required for establishing a wind power plant are heavily dependent on the location and environment of the wind power plant. In a usual case, a wind power plant requires a building permit. Building permit application is processed by a municipal board. There is also a simpler permit procedure called an action permit, but this does not properly apply in industrial grade wind power plants (Land Use and Building Act. 2003).

A recent addition to Land Use and Building Act, the Wind Power Plan Act, in some cases allows building permits to be granted directly based on the regional master plan. This applies in cases where the land use plans directly allocate the location for wind power plants (Land Use and Building Act. 2003).

In cases of wind farms of over ten wind turbines or total capacity of 30 MW, a procedure called Environmental Impact Assessment is required. Plants with lower capacity may also require an assessment, if placement of the plant is sensitive to environmental impact. The sensitivity assessment can be done by local authorities or this procedure can be initiated by residents near the prospective plant (Ministry of the Environment. Environmental Impact Assessment).

Building a wind farm in a body of water or near water is considered an activity affecting waters. According to Finland's water legislation, these types of constructions always require a permit in accordance with the Water Act.

If the wind power plant is near residential areas, the noise or flickering can disturb the people living nearby. In cases of a considerable level of nuisance, an environmental permit is required. The process of applying for an environmental permit includes a public hearing and the power plant operator must present the means and practices to mitigate the disturbance.

The general idea of land use planning is to steer wind power plants far away from residential areas, and thus remove the need to make an environmental assessment or apply for an environmental permit.

Permit applications should be submitted in writing to the relevant Regional State Administrative Agency. The authority will then make the application public as appropriate, giving the relevant authorities and anyone affected by the plans time to comment and make proposals concerning the requirements for the permit.

Other considerations affecting plant construction:

- Wind turbines are considered to be a restriction to flight traffic and construction of a wind power plant usually requires a flight obstacle permit.
- Distance from the nearest road to the wind turbine is regulated, and is calculated from the wind turbine height.



- Offshore installation of a wind power plant can be hazardous to marine traffic and regulations apply to wind turbines and power cables.
- The Transport Safety Agency and Ministry of Transport handles flight obstacle permits, safety range and shipping channel issues
- Wind power plants can interfere with radar. Radars are operated by military, marine navigation and weather services. Radar interference from a prospective wind power plant must be examined before construction. The VTT Technical Research Centre and the military have a co-operation agreement, and examinations and statements are issued by VTT
- Wind power plants near garrisons or restricted military areas are not permitted
- Regulations apply in interfacing the electric grid depending of the supplied power. Grid operator, Fingrid Oy, must be consulted in the early stage of planning a wind power plant.

### 5.2.3 Wind power subsidies

The purpose of the subsidies is to promote the production of electricity produced from renewable energy sources. The EU has set a requirement for Finland to achieve an increase in renewable energy so that it will account for 38% of total consumption by the end of 2020. The Act on Production Subsidies was introduced in March 2011.

Wind energy can get subsidies in the form of a feed-in tariff. This means that the state pays the difference between the target price and the market price. The market price is determined as the average electricity market spot price. The following tariff conditions are applied:

- Power plants generating over 0.5 MW are qualified to apply for a feed-in tariff subsidy. Limits also apply to the total capacity of installed wind power and the combined limit of installed capacity in Finland has been set at 2,500 MW, calculated from nominal power.
- Only new wind power plants (no previously used parts in any part of the installation) are accepted for the feed-in tariff system. Also, the power plant must have been taken into service after the beginning of 2009 and no other form of state subsidies may have been previously granted.
- The feed-in tariff system has two levels, basic subsidy and additional subsidy.
  - The basic feed-in tariff is limited to 12 years. The target price for the basic feed-in tariff subsidy calculation is set at €83.5/MWh.
  - Until the end of 2015, an additional subsidy will be paid and the feed-in tariff target price is €105.30/MWh instead of the basic subsidy. The time limit for any additional subsidy for a single wind power plant is three years.
- Feed-in tariff applications are processed by the Energy Market Authority. The Energy Market Authority is an expert body subordinate to the Finnish Ministry of Employment and the Economy (Energy Market Authority. The Act on Production Subsidy for Electricity Produced from Renewable Energy Sources).

### 5.3 Literature references

UNFCCC. <http://www.cop19.gov.pl/unfccc> [Viewed 19.12.2013]

Energy Market Authority. The Act on Production Subsidy for Electricity Produced from Renewable Energy Sources. 2011. [http://www.emvi.fi/files/Act\\_Production\\_Subsidies\\_Legislation\\_2011.pdf](http://www.emvi.fi/files/Act_Production_Subsidies_Legislation_2011.pdf) [Viewed 19.12.2013]

Laki uusiutuville energialähteillä tuotetun sähkön tuotantotuesta. 2010. <http://www.finlex.fi/fi/laki/alkup/2010/20101396> [Viewed 19.12.2013]

Energy Market Authority. Table of the summary of the production subsidy scheme. [http://www.emvi.fi/files/Feed\\_in\\_tariff\\_summary\\_6\\_2013.pdf](http://www.emvi.fi/files/Feed_in_tariff_summary_6_2013.pdf) [Viewed 19.12.2013]

Renewable energy database: Finland.

<http://www.res-legal.eu/search-by-country/finland/> [Viewed 19.12.2013]

National Climate and Energy Strategy 2013.

[http://www.tem.fi/files/36292/Energia-\\_ja\\_ilmastostrategia\\_netijulkaisu\\_ENGLANNINKIELINEN.pdf](http://www.tem.fi/files/36292/Energia-_ja_ilmastostrategia_netijulkaisu_ENGLANNINKIELINEN.pdf). [Viewed 19.12.2013]

Feed-in tariff of renewable energy. [http://www.tem.fi/en/energy/renewable\\_energy\\_sources/feed-in\\_tariff\\_of\\_renewable\\_energy](http://www.tem.fi/en/energy/renewable_energy_sources/feed-in_tariff_of_renewable_energy) [Viewed 19.12.2013]

Feed-in tariff.

<http://www.energiamarkkinavirasto.fi/alasivu.asp?gid=445&languageid=826> [Viewed 19.12.2013]

Ehdotus tuulivoiman syöttötariffiksi. Syöttötariffityöryhmän väliraportti.

[http://www.tem.fi/files/24646/Sy\\_tt\\_tariffiryhm\\_n\\_v\\_liraportti\\_liite\\_1.pdf](http://www.tem.fi/files/24646/Sy_tt_tariffiryhm_n_v_liraportti_liite_1.pdf) [Viewed 19.12.2013]

Energy Policies of IEA Countries - Finland

<http://www.iea.org/w/bookshop/add.aspx?id=452> [Viewed 19.12.2013]

Land Use and Building Act. 2003. <http://www.finlex.fi/en/laki/kaannokset/1999/en19990132> [Viewed 19.12.2013]

Ministry of the Environment. Natura 2000, Nature conservation areas in Finland. [http://www.ym.fi/fi-FI/Luonto/Luonnon\\_monimuotoisuus/Luonnonsuojelualueet/Naturaalueet](http://www.ym.fi/fi-FI/Luonto/Luonnon_monimuotoisuus/Luonnonsuojelualueet/Naturaalueet) [Viewed 19.12.2013]

Ministry of the Environment. Environmental Impact Assessment. [http://www.ym.fi/en-US/International\\_cooperation/Environmental\\_impact\\_assessment](http://www.ym.fi/en-US/International_cooperation/Environmental_impact_assessment) [Viewed 19.12.2013]

Finlex. Water Act. 1961. <http://www.finlex.fi/en/laki/kaannokset/1961/en19610264> [Viewed 19.12.2013]

## 6 PRE-FEASIBILITY STUDY

A pre-feasibility study is done at the beginning of a wind turbine project to evaluate whether it is worthwhile initiating a more comprehensive survey on the financial possibilities of wind turbine sites. Wind turbine project includes following phases:

- Surveying the potential sites
- Assessing the wind potential of the sites
- Pre-design of the wind turbine project
- Zoning
- Analysis of environmental impacts
- Renting or buying the wind turbine site
- Designing of the wind turbine project (electric and construction)
- Contracts (grid and electricity)
- Financing
- Building permit
- RFQs
- Supply contract
- Detailed planning
- Factory experiments
- Building and installation
- Testing
- Implementation
- O&M and fault diagnostics

## 6.1 Site investigation and evaluation of environmental impact

Site investigation includes approximations of local windiness using data acquired from the Wind Atlas. Wind Atlas data is used in pre-selecting the potential sites with sufficient windiness. After pre-selection, at least one year of wind measurements should be made to acquire the actual windiness on site which can be used in preliminary cost approximations. In pre-selection, environmental impact and the logistical features of sites should be assessed to confirm the feasibility of the project.

The best locations for wind power regarding windiness are coastal, sea and fell areas. In Finland, the best wind conditions are in Ahvenanmaa and Southwest Finland and, moving northeast, wind conditions get progressively weaker. In the pre-feasibility study, wind measurement is done at suitable sites which have been selected from the Wind Atlas.

Impact on landscape must be judged in the designing phase of the wind farm project. The most valuable natural resources and cultural landscapes should be considered worth of saving when pre-selecting the wind turbine sites. It should also be noted that selecting coveted cultural landscapes as wind turbine sites usually leads to legal action, which increases price and postpones the project. In the planning phase, it is possible to visualize how a wind turbine or wind farm will affect the view using photo fitting programs (Ministry of the Environment. Tuulivoimarakentamisen suunnittelu. p. 55 – 57. 2012).

When planning a wind turbine or wind farm near residential areas, it is crucial to make sure that the chosen wind turbine will not emit disturbing shadow flicker. Shadow flicker is created when sunrays shine behind the wind turbine and the blades get in way of the Sun's rays causing flickering shadows. Shadow flicker may extend up to a couple of kilometers depending of the size of the wind turbine, its location and the angle of sunlight (Ministry of the Environment. Tuulivoimarakentamisen suunnittelu. p. 61. 2012).

Noise coming from a wind turbine is created by the movement of the mechanical parts and the rotor blades. Estimations of noise distribution can be illustrated on the local map of the area, thereby allowing more precise plans to be made to reduce noise pollution. Theoretical background noises play a significant role in considering a site for a wind turbine. Tables 6.1 and 6.2 illustrate noise regulations in Finland and theoretical background noise at different sites (Pöyry. Varsinais-Suomen tuulivoimaseelvitys. Teknistaloudellinen esiselvitys ja maisemavaikutusten arviointi. p. 49 – 58. 2007).

**Table 6.1 Noise regulations in Finland.**

Noise regulations		
	Population center	Outside population center
At day	55 dB	45 dB
At night	45 – 50 dB	35 – 45 dB

**Table 6.2 Theoretical background noise. Adapted from (Pöyry)**

Theoretical background noise	
Beach on the wind side	55 – 60 dB
Nearby forest line	45 – 54 dB
Average living room	35 – 45 dB

In Finland, there has been some debate about the clarity of the noise regulations and this has led to problems in many projects. There are plans to release new regulations in the second quarter of 2014 which may include even more strict regulations regarding noise levels. New regulation as it is presented would demand that nighttime noise levels do not exceed 25 dB (STY ry. Participant meeting on sound issues).

There are no limitations concerning movement of people in the area after construction work has ended. During winter, it is possible that ice formed on the propeller blades may fall as far as 1½ times the height of the wind turbine, thereby forming a large hazardous area around the wind turbine (Ramboll. Jäävaaraselvitys. 2011).

### 6.1.1 Investment costs

Wind turbine investment cost usually varies from €1.1 to 2.6 M/MW depending on the site’s logistical features, distance to the power grid, the rated power of the turbine and the amount of turbines. The investments costs of building wind turbines offshore are generally considered to be €3.1 to 4.7 M/MW which is 2 – 3 times higher than for onshore wind turbines (IEA, Technology roadmap – Wind Energy. p. 14. 2013).

As seen on Figure 6.1, most of the investment cost consists of wind turbine parts, grid connection and foundation, and they make up as much as 90% of the total investment. Lifts and transportation are often included in the costs, so these are considered to be within the turbine section. These diagrams are only approximations of wind turbine investment cost distributions, and the overall distribution somewhat varies when building one or multiple turbines simultaneously (EWEA, The Economics of Wind Energy p. 37. 2009).

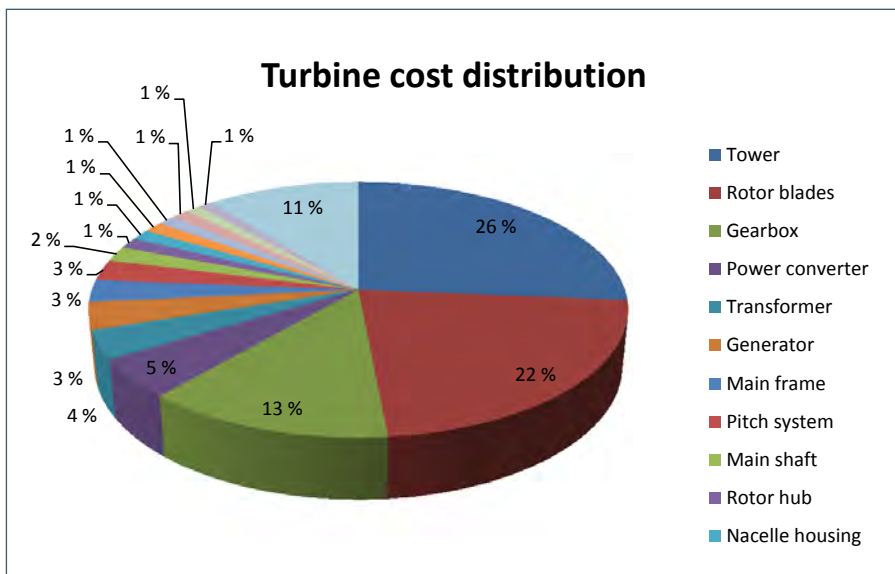

Figure 6.1 Turbine cost distribution (EWEA, The Economics of Wind Energy p. 37. 2009)

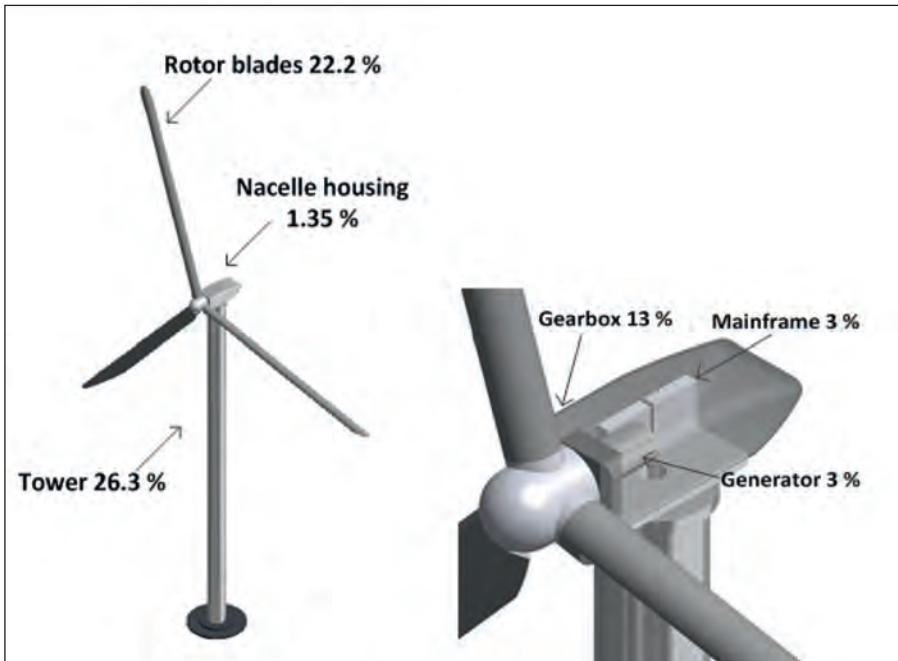

Figure 6.2 Visualization of the wind turbine part cost distribution (EWEA, The Economics of Wind Energy p. 37. 2009)

As stated on Figure 6.1, wind turbine grid connection takes approximately 9% of total investment. Grid connection cost varies considerably depending on the location and voltage level of the nearest grid. In an ideal case, there is a distribution station with adequate capacity nearby, but this is not always the case and a new distribution station may have to be built (EWEA, The Economics of Wind Energy p. 37. 2009).

Wind turbines of less than 5 MW can be directly connected to the stem grid with a voltage level of 110 kV without an electric power distribution station. In this specific case, the price of the grid connection will be about €0.5 M. When the power of 5 MW is surpassed, the connection must be done through a distribution station. Depending on the location and power of the wind turbine, a new distribution station may have to be built. In Table 6.3, approximations of the connection costs and building costs of the distribution stations are presented (Fingrid. Grid connection fees, Terms and conditions).

**Table 6.3 Fingrid grid connection prices (Fingrid. Grid connection fees)**

Connection voltage	Connection to electric power distribution station	Electric power distribution station has to be built
110 kV	0.5 - 0.6 M€	3.5 - 5 M€
220 kV	1.2 M€	5 - 7 M€
440 kV	2 M€	6 - 8 M€

Foundations take around 7% of total investment costs. Usually onshore wind turbines use either a concrete gravity foundation or anchored foundation. On the gravity foundation, the required supporting force comes from the large concrete base, whereas in anchored foundation the counter force is taken from the bedrock with anchors. Foundation costs usually include earth-moving and are heavily influenced by the proximity of the existing road system and the type of the ground. Because wind turbine parts, especially rotor blades, are quite long and heavy, demands are placed on existing and future infrastructure (EWEA, *The Economics of Wind Energy* p. 37. 2009).

### 6.1.2 Operating and maintenance costs

Operating and maintenance (O&M) costs are relatively inexpensive when comparing them to other forms of energy production with additional fuel expenses. O&M costs for onshore wind turbines are usually around €10 - 15/MW and for offshore wind turbines around €20 – 30/MW. Most operating and maintenance costs come from preventive maintenance and from fault-fixing work. In Finland O&M costs have been relatively high compared to other countries with more wind turbines. According to IEA Technology Review 2013 – Wind Energy, the average O&M in Europe in 2009 was about €30 t/MW/year and in 2013 was about €17 t /MW/year, which almost halves O&M costs (IEA. p. 14 - 16. 2013) (Vakkilainen, *Sähkötuotantokustannukset 2012*, p. 7).

The operating and maintenance costs of wind turbines comprise spare parts, land rent, insurance, taxes, administration, control and internal consumption. Maintenance and repair costs are affected among other things by the size of the wind farm, maintenance distances and the reliability of maintenance contracts (Mikkonen. *Mitä tuulivoima maksaa*. p. 36 - 39 2011).

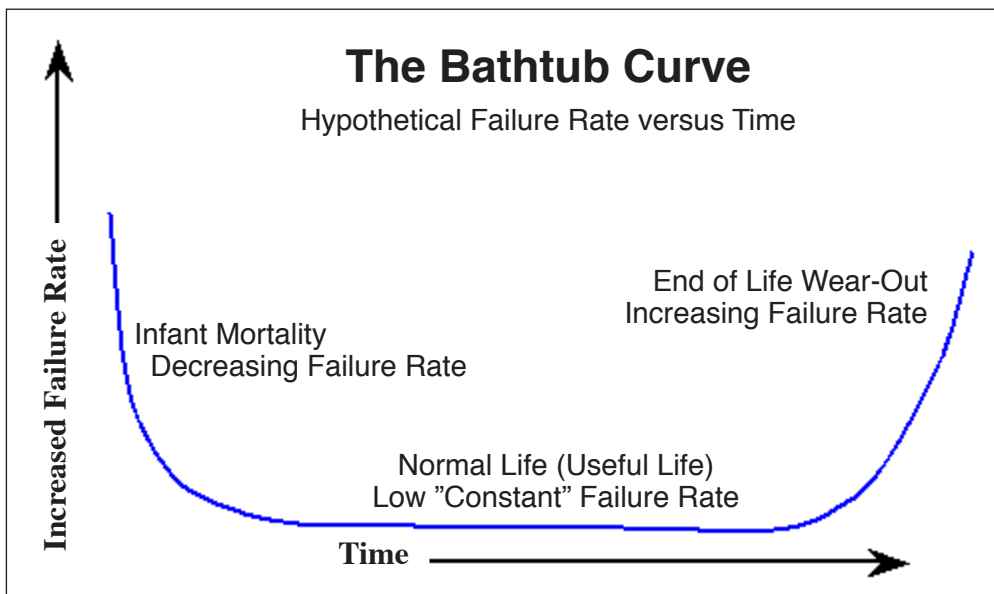

Figure 6.3 Classical bathtub curve (Dennis W. *The bathtub curve and product failure behavior*. 2002)

Figure 6.3 illustrates failure rates over time. After implementation, there are infant mortalities which progressively get lower as the wind turbine ages. However, wear-out failures start to increase as the wind turbine ages. There are also random failures associated with random part faults and failures caused by extrinsic factors (Dennis W. The bathtub curve and product failure behavior. 2002).

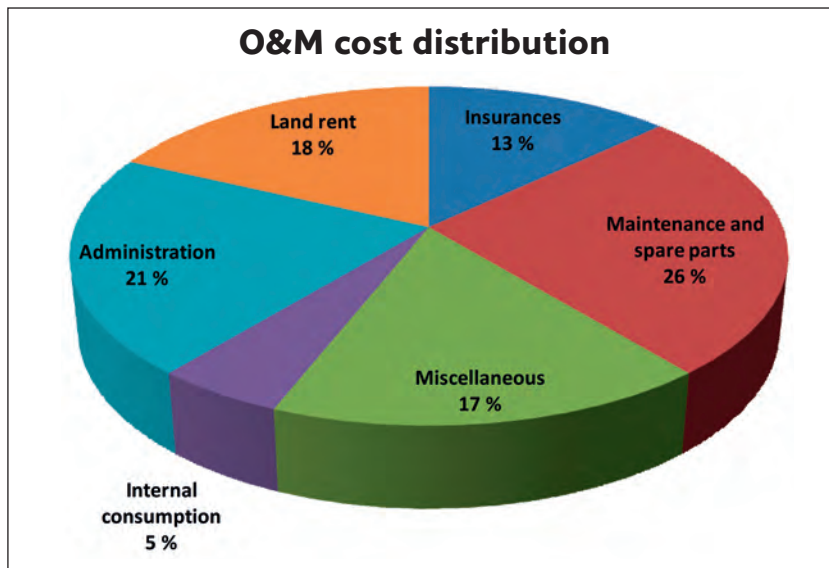

Figure 6.4 Annual O&M costs distribution of wind turbines in Germany | 1997-2011 | . Adapted from (Mikkonen. Mitä tuulivoima maksaa. p. 37. 2011)

### 6.1.3 Production costs

In Finland production costs are usually around €50 to 90/MWh depending on wind conditions, location and other factors. Repayment of investment in Finland is considered to be based on a 4-6% real interest rate and on a 20-year repayment period. The length of the repayment period for a wind turbine or larger wind farm is affected by the utilization period of the maximum load, tariff, operation and maintenance costs, interest rate and loan period. The repayment period of the loan is one of the most important factors in estimating whether the wind turbine project is feasible or not. Figure 6.5 presents an example of the lifetime profit of a wind turbine investment (Mikkonen. p. 43. 2012).



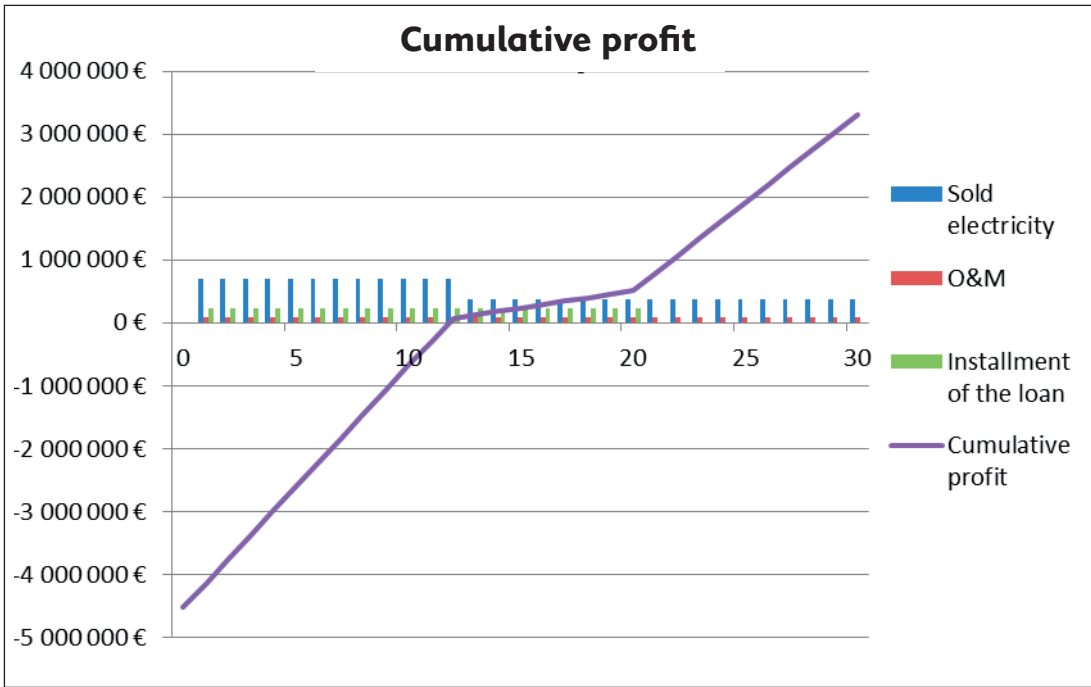

Figure 6.5 Example of the lifetime profit of a wind turbine investment

## 6.2 Engineering calculations and Weibull distribution

The available power in wind per unit area can be calculated with the following equation.

$$\frac{P}{A} = \frac{1}{2} * \rho * v^3$$

Equation 6.1 Power per unit area (Huhtinen, Voimalaitostekniikka, p. 284, 2008)

where

$\frac{P}{A}$  power per unit area  $\frac{W}{m^2}$

$\rho$  density of air  $\frac{kg}{m^3}$

$v$  wind speed  $\frac{m}{s}$

Betz' law limits the energy which can be extracted from available wind energy to 59%. However, current wind turbine technology can only extract 45 – 50% of wind energy (Huhtinen, p. 284, 2008).

Wind turbine rotor power for each wind speed can be calculated with the following equation.

$$P_{electricity} = \frac{1}{2} * c_e * \rho * A * v^3$$

Equation 6.2 Produced electricity at a given wind speed (Huhtinen, p. 284, 2008)

where

$P_{rotor}$	wind turbine rotor power	$W$
$c_e$	power coefficient at given wind speed	-
$\rho$	density of air at given temperature	$\frac{kg}{m^3}$
$A$	rotor swept area	$m^2$
$v$	wind speed	$\frac{m}{s}$

Power coefficient varies from 0 to 0.50 and is a function of wind speed. Power coefficient can be given as an efficiency of producing electricity ( $c_e$ ) or as an efficiency of producing mechanical energy ( $c_p$ ). Hereafter power coefficient is the efficiency of producing electricity. These coefficients are usually given by the wind turbine manufacturer. This has been confirmed from the manufacturer power curves of various commercial turbine types which will not be presented in this study.

The swept area of the rotor is calculated from the following equation:

$$A = \pi \times \left(\frac{D}{2}\right)^2$$

Equation 6.3 Swept area of the rotor

where

$D$  rotor diameter  $m$

Drivetrain efficiency consists of gearbox, generator and power converter efficiencies.

Utilization period of maximum load can be calculated from annual energy production and rated power with the following equation:

$$t_{peak} = \frac{E_{annual}}{P_{peak}}$$

Equation 6.4 Utilization period of the maximum load

$t_{peak}$  Utilization period of maximum load h  
 $E_{annual}$  annual energy output MWh  
 $P_{peak}$  rated power MW

Utilization period of maximum load can also be reported as a capacity factor by dividing it by annual hours:

$$CF = \frac{t_{peak}}{8760}$$

Equation 6.5 Capacity factor

$CF$  capacity factor %  
 $t_{peak}$  Utilization period of maximum load h

Weibull parameters can be extracted from the Finnish Wind Atlas in order to make a Weibull approximation of the wind profile. Weibull distribution is a mathematical approximation for annual wind speed distribution and can be used to calculate wind turbine energy output.

Weibull distribution is also used with measured wind data in order to simplify calculations for produced energy.

$$F(v, \lambda, k) = \frac{k}{\lambda} * \left(\frac{v}{\lambda}\right)^{k-1} * e^{-\left(\frac{v}{\lambda}\right)^k}$$

Equation 6.6 Weibull-distribution

where

$F(v, \lambda, k)$	wind speed distribution	%
$\lambda$	Weibull scale parameter	-
$k$	Weibull shape parameter	-

It should be noted that the Weibull distribution does not account for zero production hours and, if the energy production is directly calculated from the Weibull-distribution, it gives higher annual energy output than it actually is in real-world conditions.

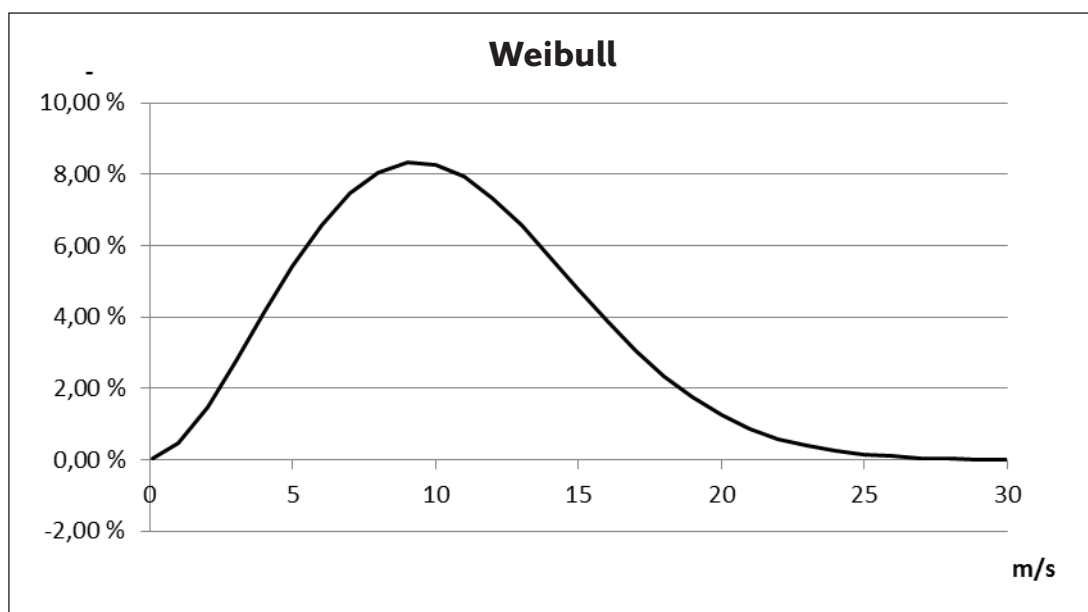

Figure 6.6 Example of Weibull distribution with  $k = 2,3$  and  $\lambda = 11,3$

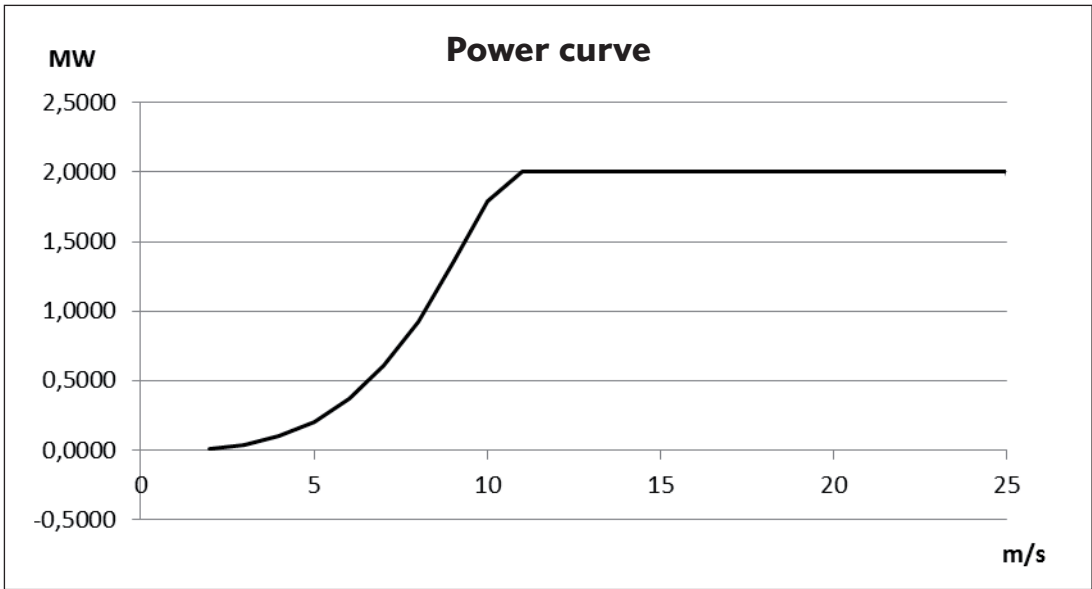

Figure 6.7 Example of a wind turbine power curve

Produced energy at given wind speed can be calculated by multiplying the Weibull distribution and wind turbine power curve by annual hours of 8,760.

$$E(v) = F(v, \lambda, k) * P_{curve}(v) * 8760h$$

Equation 6.7 Produced energy at a given wind speed

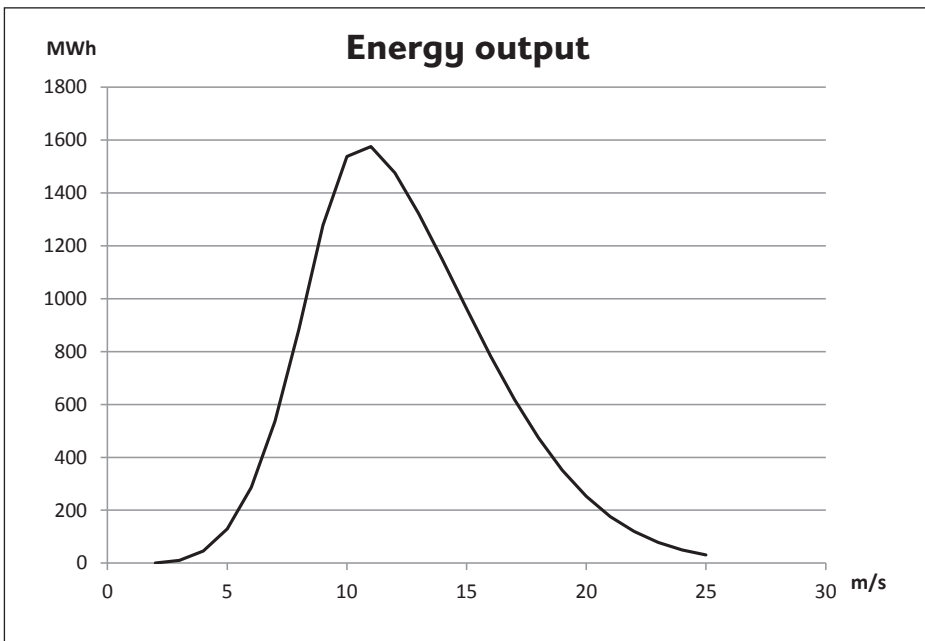

Figure 6.8 Annual energy output distribution calculated from two earlier figures 6.7 and 6.8

$$E_{annual} = \sum_{i=1}^v F(v, \lambda, k) * P_{curve}(v) * 8760h$$

Equation 6.8 Annual energy output

### 6.3 Example of a wind turbine project

The following pre-feasibility project is **completely hypothetical** and there have been no plans to build a wind turbine on a chosen site.

This wind energy pre-feasibility project was made for Katariinan Meripuisto at Kotka in Kymenlaakso. Katariinan Meripuisto is situated at the south-east tip of Kotkansaari and the chosen region is defined in Figure 6.9. The site was chosen for wind turbines because of its good windiness according to the Finnish Wind Atlas. The windiness of the region is illustrated in Figure 6.10 in a 250x250 meter wind atlas grid. In a detailed economic study, it would be necessary to get a higher-resolution wind atlas grid from the Finnish Meteorological Institute to make more accurate assessments of site usability for wind energy production. However, for this survey this 250x250 meter grid is sufficient.



Figure 6.9 Possible wind turbine site at Kotkansaari

The chosen site covers more than 20 hectares and, according to the Wind Atlas, good wind turbine sites are situated on the southern coastline while wind conditions weaken going north along the coastline. Figure 6.11 also illustrates that about 50% of wind blows from the south-west.



Figure 6.10 Average wind speed at examined site (Wind Atlas)

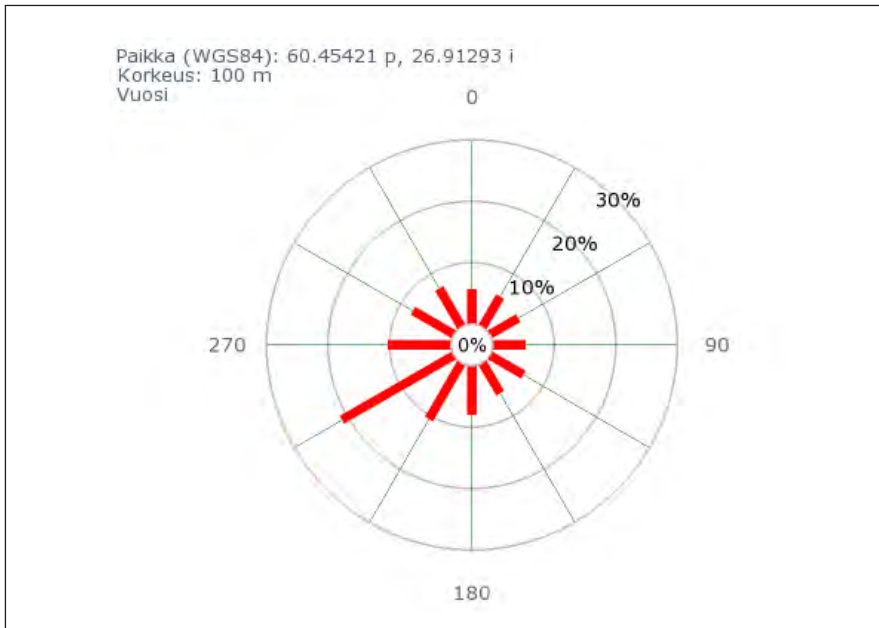

Figure 6.11 Wind rose at the examined site at a height of 100 m (Wind Atlas)

According to the grid operator Kymenlaakson Sähkö, the local 20 kV distribution system can support up to three 2.5 MW wind turbines. This reduces costs significantly compared to connecting to 45 kV or 110 kV power lines.

**Table 6.4 Data from suitable wind turbines**

Manufacturer	Turbine type	Nominal power	Rotor diameter	Hub Height	Wind Class
–	–	MW	m	m	–
Turbine	X	2.35	92	104	IIA
Turbine	Y	2.3	113	99,5	IIA

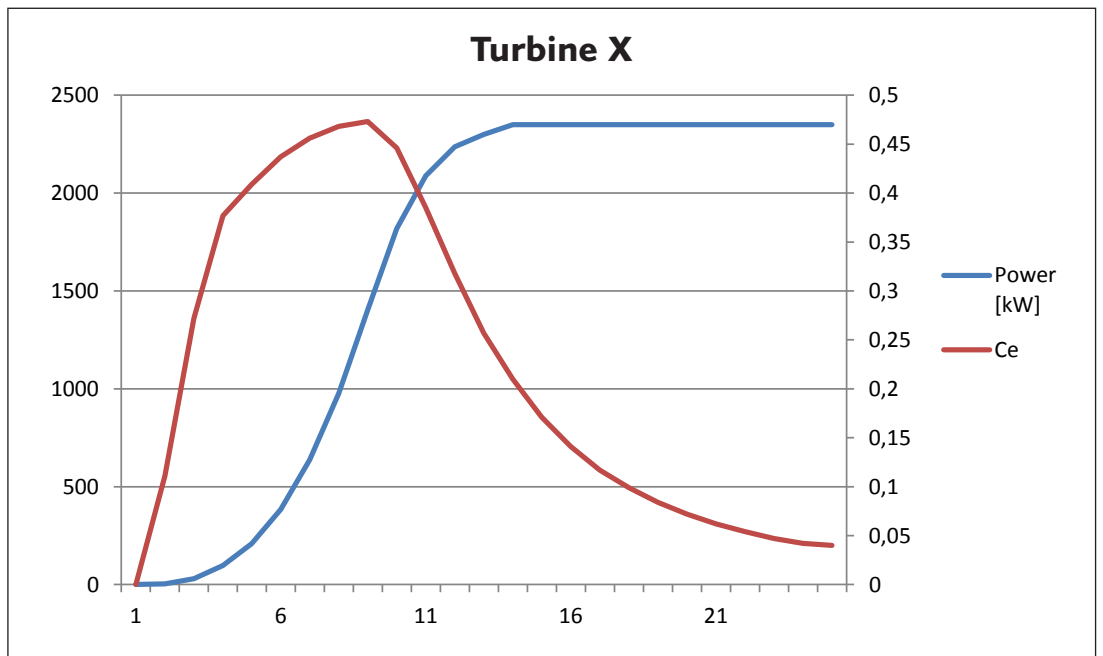

Figure 6.12 Power curve of Turbine X



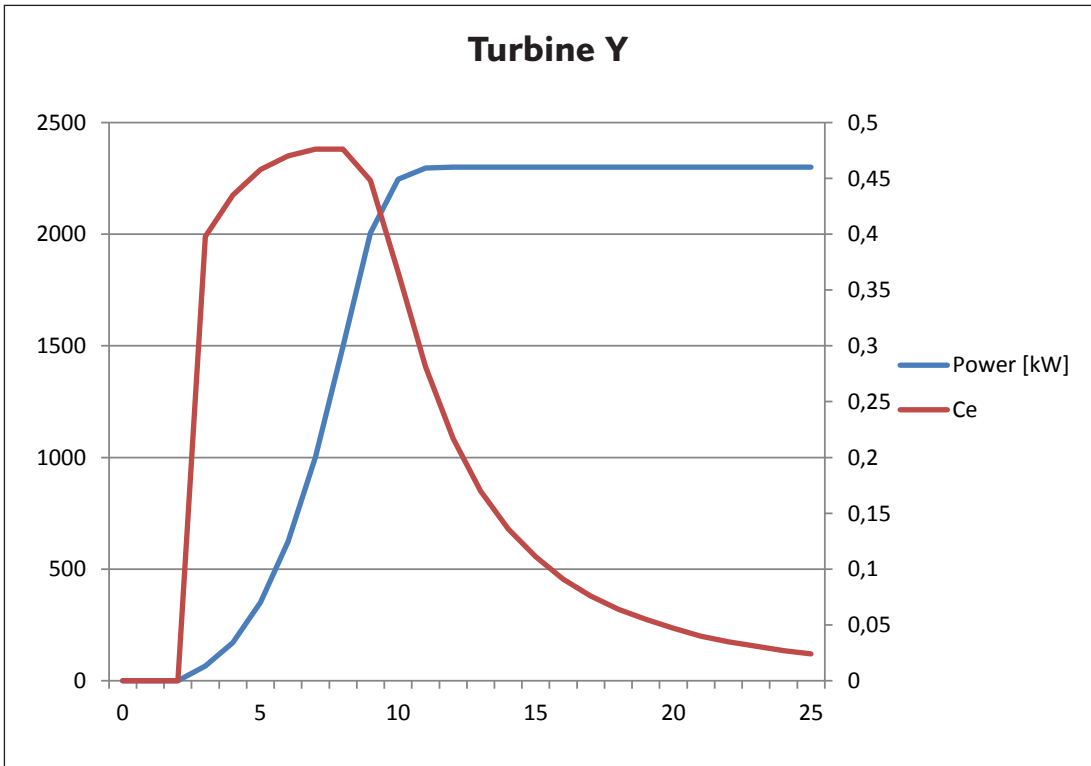

Figure 6.13 Power curve of Turbine Y

The Wind Atlas gives the following Weibull-parameters for the possible wind turbine site at a height of 100 m:

$$A = 9.11 \text{ and } k = 2.209$$

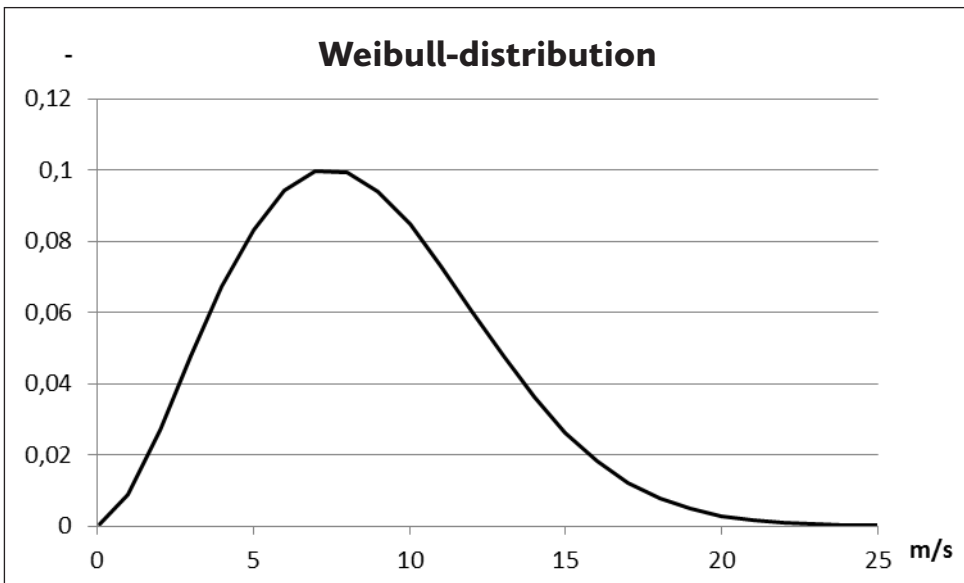

Figure 6.14 Wind speed distribution on site.

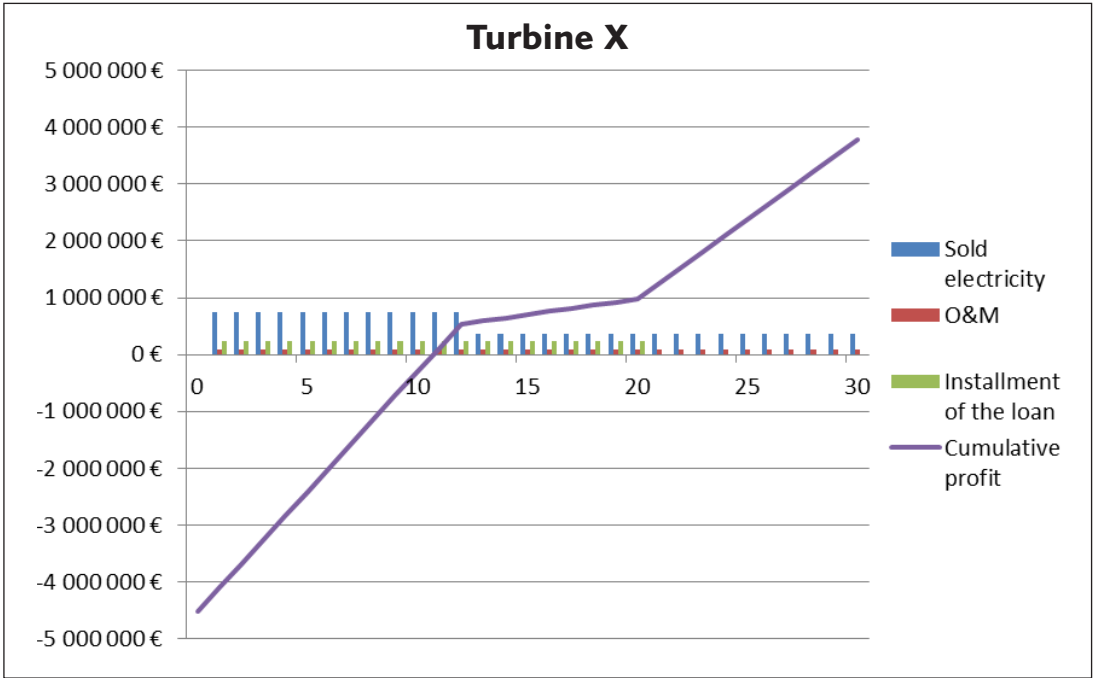

Figure 6.15 Cumulative profit for Turbine X with assumed investment of €1.2 M

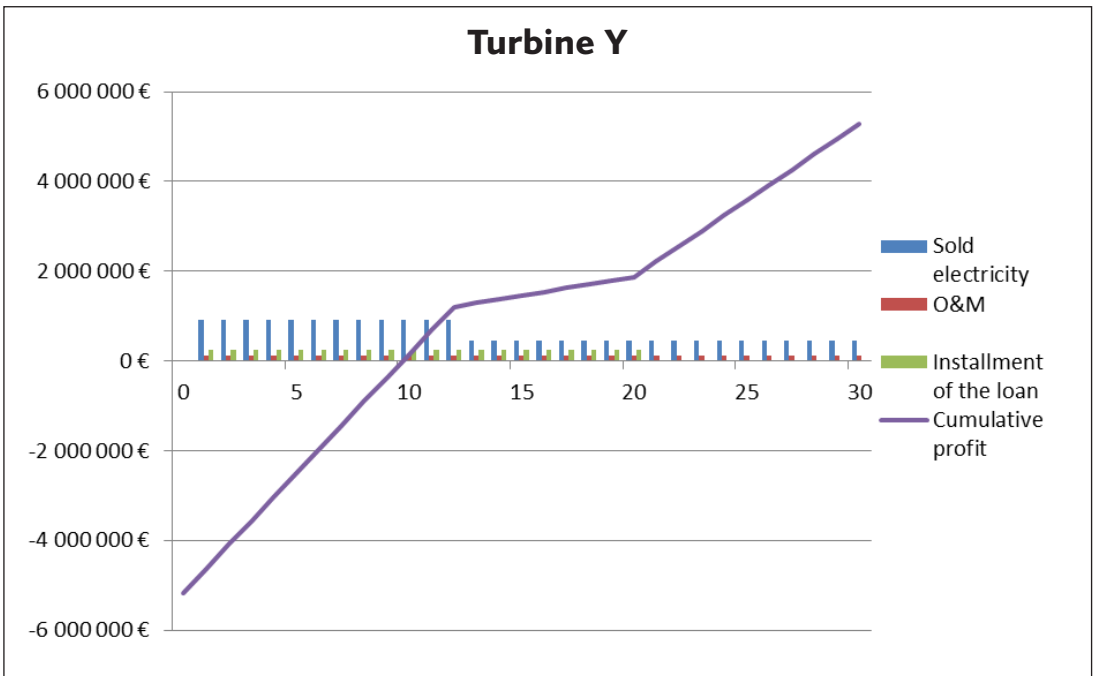

Figure 6.16 Cumulative profit for Turbine Y with assumed investment of €1.4 M

**Table 6.5 Turbine X & Y electricity production and ROI**

Manufacturer	Turbine type	Annual energy production	Annual sold electricity	ROI
–	–	MWh	k€ / a	a
Turbine	X	8 886	521	11
Turbine	Y	10 882	635	10

Table 6.5 gives some financial data for Turbine X and Turbine Y on the chosen site. Turbine Y seems to be somewhat better for the site with a faster return on investment by one year. However, one should also note that Turbine Y has a higher investment cost which means higher risks.

## 6.4 Literature references

Ministry of the Environment. Tuulivoimarakentamisen suunnittelu. 2012. [http://www.ym.fi/fi-FI/Ajankohtaista/Julkaisut/Ymparistohallinnon\\_ohjeita\\_OH/OH\\_42012\\_Tuulivoimarakentamisen\\_suunnitt%288995%29](http://www.ym.fi/fi-FI/Ajankohtaista/Julkaisut/Ymparistohallinnon_ohjeita_OH/OH_42012_Tuulivoimarakentamisen_suunnitt%288995%29) [Viewed 19.12.2013]

Pöyry. Varsinais-Suomen tuulivoimaselvitys 2007 – teknis-taloudellinen esiselvitys ja maisema-vaiku-tusten arviointi. 2007. <http://www.varsinais-suomi.fi/images/tiedostot/Maankaytto/2010/yhdyskuntahuolto/tuulivoima2007raportti.pdf> [Viewed 19.12.2013]

Finnish Wind Power Association. Participant meeting on sound issues.

Ramboll. Jäävaaraselvitys. 2011. [http://www.rauma.fi/tevi/kaavoitus/Materiaalit/vireill%C3%A4/asemakaavat/AK13-009Lakari/tuulivoimaselvitykset/82138782\\_Rauma\\_J%C3%A4%C3%A4vaaraportti\\_2011-12-20.pdf](http://www.rauma.fi/tevi/kaavoitus/Materiaalit/vireill%C3%A4/asemakaavat/AK13-009Lakari/tuulivoimaselvitykset/82138782_Rauma_J%C3%A4%C3%A4vaaraportti_2011-12-20.pdf) [Viewed 19.12.2013]

IEA, Technology Roadmap – Wind Energy. 2013. <http://www.iea.org/publications/freepublications/publication/name,43771,en.html> [Viewed 19.12.2013]

EWEA. Economics of Wind Energy. 2009. [http://www.ewea.org/fileadmin/ewea\\_documents/documents/00\\_POLICY\\_document/Economics\\_of\\_Wind\\_Energy\\_\\_March\\_2009\\_.pdf](http://www.ewea.org/fileadmin/ewea_documents/documents/00_POLICY_document/Economics_of_Wind_Energy__March_2009_.pdf) [Viewed 19.12.2013]

Fingrid, Grid connection prices. Terms and conditions. <http://www.fingrid.fi/en/customers/connection/connectionfees/Termsconditions/Pages/default.aspx> [Viewed 19.12.2013]

Fingrid, Grid connection prices <http://www.fingrid.fi/en/customers/connection/connectionfees/Pages/default.aspx> [Viewed 19.12.2013]

Vakkilainen, Sähköntuotantokustannukset 2012. <http://urn.fi/URN:ISBN:978-952-265-341-3> [Viewed 19.12.2013]

Dennis W. The bathtub curve and product failure behavior. 2002. <http://www.weibull.com/hotwire/issue21/hottopics21.htm> [Viewed 19.12.2013]

Mikkonen. Mitä tuulivoima maksaa? 2011. [http://www.tuulivoimayhdistys.fi/sites/www.tuulivoimayhdistys.fi/files/anni\\_mikkonen\\_gradu\\_korjattu\\_240412.pdf](http://www.tuulivoimayhdistys.fi/sites/www.tuulivoimayhdistys.fi/files/anni_mikkonen_gradu_korjattu_240412.pdf) [Viewed 19.12.2013]

Huhtinen, M. Korhonen, R. Pimiä, T. Urpalainen, S. Voimalaitostekniikka. 2008. Otava.

Wind Atlas. Map Interface. <http://tuuliatlas.fmi.fi/en/> [Viewed 19.12.2013]

# 7 WIND TURBINE PROJECTS

The main focuses of this chapter are the logistics and the administration of the wind turbine projects. Figure 7.1 presents a possible wind turbine project organization.

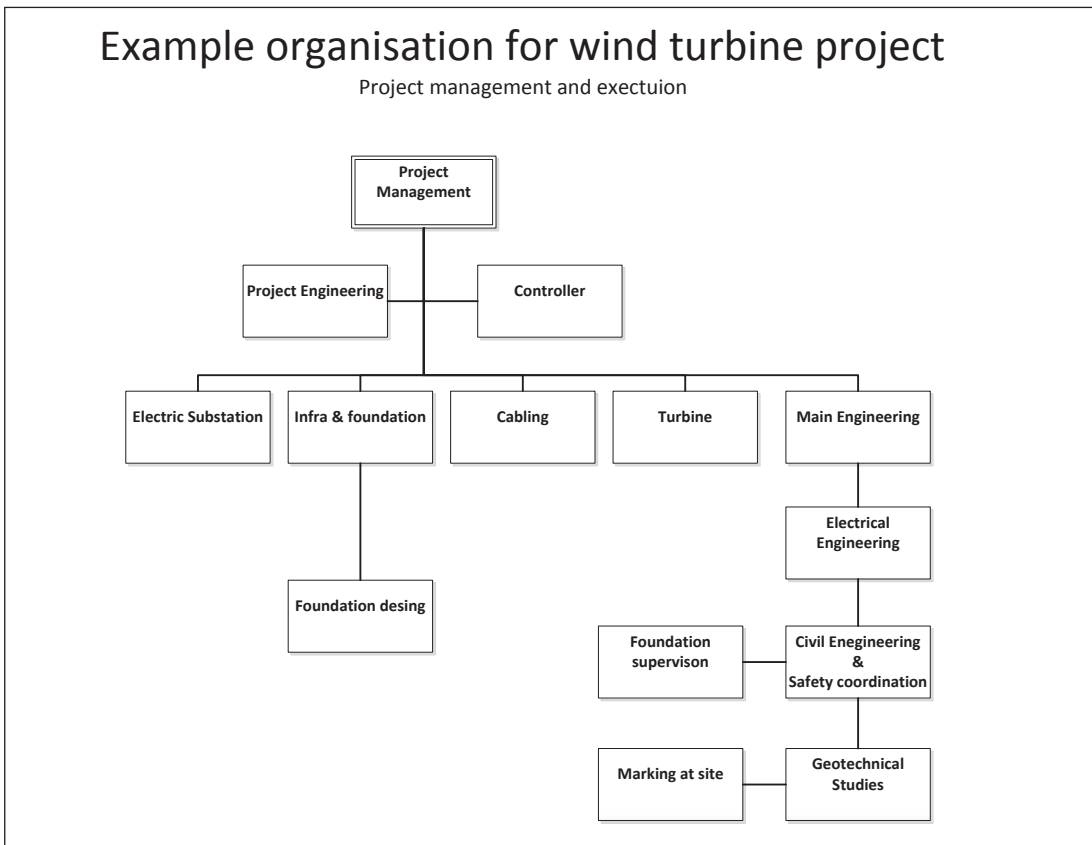

Picture 7.1 Example organization for wind turbine project

An example of the required labor for the wind turbine project is illustrated in Table 7.1. The example is based on a wind farm with seven 3 MW wind turbines. A wind farm of this size generally needs 34 workers (5 supervisors with 29 subordinates). The table shows that the construction phase provides most of the employment over the wind turbine’s lifetime.

**Table 7.1 Example of labor needed for wind turbine installation**

	<b>Work supervision</b>	<b>Employee</b>
Foundation	1	10
Roads & building area	1	5
Earthmoving and foundation total	2	15
Mechanical intallation	3	10
Lifts	0	2
Capeling	0	2
Turbine installation total	3	14

The temporary construction site must be reported to occupational health and safety authorities. The main contractor, site foremen and supervisor of electrical work must be noted in the declaration. The installation, lifting and implementation work must also be reported in the previous declaration. Occupational health and safety inspections are conducted on a regular basis.

## 7.1 Project phases

A wind turbine construction project can be divided in following phases:

- Construction work
- BOP (Everything except turbine and its elements)
- Turbine delivery
- Implementation

**Construction work** includes excavation work, foundation and infrastructure. Infrastructure is built to bear heavy lifting equipment and the incline should be zero degrees. The foundation consumes about 60 tonnes of steel and 100 truckloads of concrete. The overall weight of the foundation depends on turbine size but is usually about 1,000 tonnes.

**BOP** includes building of all auxiliary components which are not necessary for the turbine to function but are necessary for feeding power into the grid. These components include an electric station, electrical and communication systems and cabling. Basically every electric system after the wind turbine generator is included in this phase. The ownership of the turbine passes to the contractor as turbines arrive at the erection site.

**Turbine delivery** includes turbine *manufacturing, delivery* and *erection*.

*The turbine is manufactured* by the company which won the bid. Responsibility for inspection of the turbine is left to the contractor before erection.

*Delivery of the turbine* is thoroughly investigated because the turbine requires special measures for sea and road routes. For example, turbine blades are transported on the deck of a ship because they are usually over 60 metres long. After ship transport, turbine parts are unloaded onto special transport trucks and transferred to the erection site. During road transportation, it may be necessary to remove traffic signs and streetlights temporarily.

*Erection of a wind turbine* can be roughly divided in the following three phases:

- Erection of the crane lasts roughly three days and a couple of extra days onsite costs tens of thousands of euros. A crane is built with the help of an auxiliary crane on a 200m-long road.
- Erection of the tower, lifting of the nacelle and lifting of the gearbox and the generator.
- Lifting of the rotor consist of two phases. The first rotor blades are joined to the hub, then it is lifted and fastened to the nacelle.

**Implementation** is started after assembly of the turbine. Based on turbine testing, Fingrid approves grid connection. Fingrid requirements are confirmed with calculation documents, tests made elsewhere, certifications, wind turbine tests and long-term usage. After Fingrid approval, the wind turbine can be handed over to the customer.

Turbines, electric station, cabling, automation and infrastructure belong to the field of operation and maintenance. This is discussed in depth in Chapter 4.

## 7.2 Case Mäkelänkangas

The following chapter Case Mäkelänkangas is based on “Logistical Report of a Wind Farm” published in 2012. The report was made by the Kymenlaakson University of Applied Sciences and North European Logistics Institute which is a development actor governed by Kyamk (NELI. 2013).

This is a short introduction to Suomen Voima’s wind farm project “Mäkelänkangas”. The supplier of the wind turbines was Hyundai Heavy Industries. The foundation-laying, erection of the tower and logistics were executed by Empower Oy. Empower Oy is also in charge of the maintenance.

From a logistics point of view, this was large project even though there were only four wind tur-

bines to be constructed on-site and the site was relatively close to the harbor. It is located in an area of Hamina called Mäkelänkangas, an industrial area only ten kilometers from the port of HaminaKotka. Even though this project included only four turbines and transportation distances were short, the project still required heavy logistics. Transportation of parts included heavy, long parts and wide parts and was done on public roads.

There was no exact timetable for the assembly of the turbines due to the fact that weather conditions played a large role in the operation. High winds and other poor weather conditions could have prevented assembly. Estimated assembly time was about one month and this included uncertainties caused by weather conditions. Unloading and transportation of the wind turbine parts was started in Week 9. Week 10 was reserved for inspections of the parts and assembly.

This next Figure 7.2 is a timetable of project Mäkelänkangas wind turbine 1. It shows how the project was executed. The erection and commissioning phase includes the whole four-turbine project. The time axis is in months.

### 7.2.1 Unloading of the parts and assembly

The parts were unloaded from the ship Ellenborg (renamed Clipper Amber), between 27 and 29 February 2012 by a company called Sterm. Unloading was done at the Palokangas Dock the port of HaminaKotka.

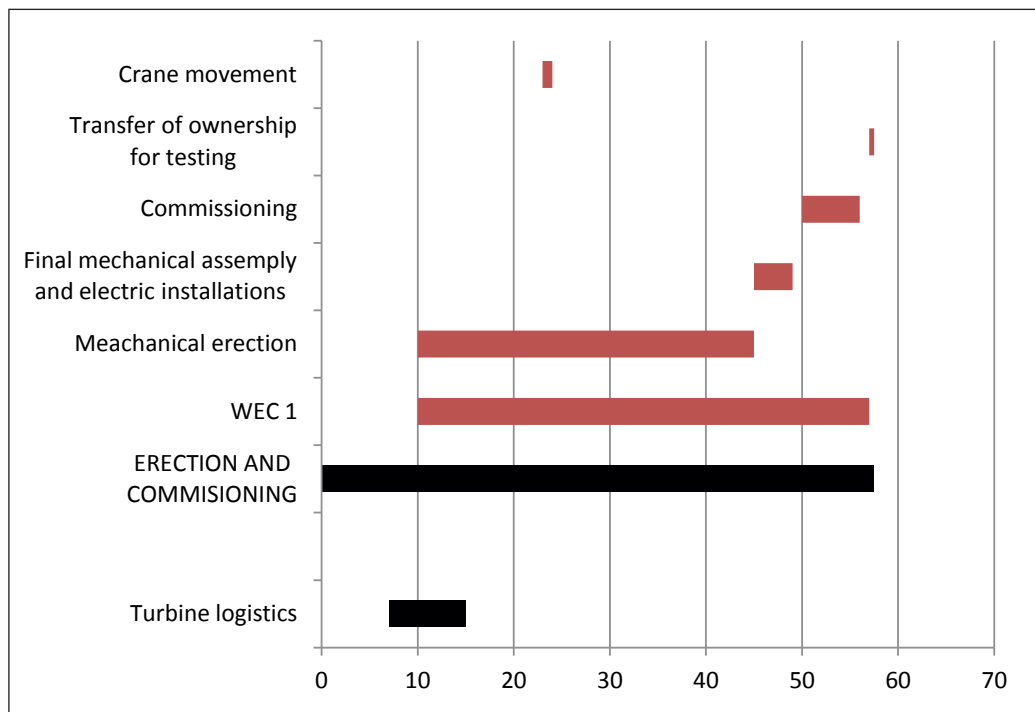

Figure 7.2 Mäkelänkangas wind turbine 1 construction timetable



Due to the fact that parts of wind turbines are heavy and can be as long as 45m, there were two cranes unloading them. The heaviest parts were tower parts and blades requiring two cranes. The lowest part of the tower weighed 80 tonnes. Most of the other parts could be lifted with a single crane. There were various attachment types for cranes (shackles, straps and chains) depending on the part to be lifted.

Lifting was done according to regulations and planning of every lifting operation was done carefully. When lifting had to be done in a way that varied from the original lifting plan, new lifting plan had to be accepted and confirmed by Empower. Empower co-operated with Hyundai and contacted it to authorize any special lifts.

Lifting, moving and assembly required heavy machinery like cranes, heavy-duty trucks and forklifts. In the end, delays caused by the high wind speed amounted to eight working days.

### **7.2.2 Experiences of Mäkelänkangas in operation**

The Mäkelänkangas wind farm had some turbine noise problems. Noise is mainly in the low frequency spectrum but there is also some noise in the high frequency spectrum. Noise in the low frequency spectrum is the largest issue because of its high permeability. Problems took a while to be solved and some massive operations were required. The source of the noise problems was located to the gearbox. Because of these problems, start-up of the wind farm was held up until the problems were solved. Turbines 1 and 2 were put into continuous energy production at the end of 2012 while turbines 3 and 4 were put into continuous energy production on 12.8.2013 (Suomenvoima 2012)(Suomen voima 2013).

This wind farm project has shown that there are unexpected aspects in building wind farms. Changes in these unexpected events could be reduced with more accurate design and implementation. Problems like noise can reduce power production significantly if the production must be limited to certain times during the day or if the nominal power must be reduced. This will have effect on profits earned from the wind farm.

## **7.3 Wind turbine projects in Kymenlaakso**

This chapter tells about wind power projects in south-east Finland. The list presented next illustrates the projects that are currently in the planning phase. Bolded projects are existing wind turbines/farms as of 2013. The following Table 7.2 is a combination of information from news articles, websites of companies and the project list from Suomen Tuulivoimayhdistys ry (Tuulivoimayhdistys 2013).

Table 7.2. Wind farm projects in the area of Kymenlaakso

Company, Project	Place	Turbines	Nominal Output MW
Haminan Energia Oy, <b>Summa and port of HaminaKotka</b>	<b>Summa and port of HaminaKotka</b>	4	12
Summa phase IIa	Hailikari and Koirakari	2	6
Harvajanniemi	Harvajanniemi, Virolahti	20	120
Vallanjärvi	Vallanjärvi, Miehikkälä	9	27
Ilmatar Windpower Oyj	Mäyränmäki, Hamina	40	240
Innopower Oy	Mussalo, Kotka	2-3	6-9
Kotkamills Oy	Kotkansaari, Kotka	3-4	6-9
Kotkan Energia Oy, Rankki 1	Rankki, Kotka	8	24
Rankki 2	Rankki, Kotka	3	9
<b>Mussalo</b>	<b>Mussalo, Kotka</b>	2	<b>4,7</b>
<b>WT-Ilmari</b>	<b>Mussalo, Kotka</b>	1	<b>1</b>
WT1	Mussalo- Hanskinmaa, Kotka	1	2-3
WT2	Mussalo, Kotka	1	2-3
WT3, offshore	Mussalo-Vehkaluoto, Kotka	1	2-3
NWE Sales Oy	Mustakorpi, Pyhtää	6	27
Oxford Intercon Finland Oy	Kouvola	8-13	16-39
SG-Power Oy	Karhulanniemi, Kotka	2	
Stora Enso Oy	Sunila, Kotka	4	12
Suomen Merituuli Oy	Pirnuora, Pyhtää	9	21,6-27
<b>Suomen Voima Oy</b>	<b>Mäkelänkangas</b>	<b>4</b>	<b>12</b>
Tornator	Struka and Korkiaharja, Pyhtää	6	14,4-18
Tuulipuisto Oy Karhuniemi	Karhuniemi, Kotka	2	4,6-6
TuuliSaimaa Oy, TuuliPyhtää TuuliHalla	Purola, Pyhtää Halla, Kotka	9 4	27 12
TuuliWatti Oy, Heinsuo Oravakorpi	Heinsuo, Pyhtää Oravakorpi, Virolahti	4 6	18 18
Others, Mustakorpi	Mustakorpi, Pyhtää	8	24-36

## 7.4 Literature references

Suomen Tuulivoimayhdistys ry. 2013. Tuulivoimatietoa-sivusto. Available through: <http://www.tuulivoimayhdistys.fi/hankkeet> [Viewed 16.9.2013]

NELI. 2013. Web pages. Available through: [http://www.neli.fi/folders/Files/Hankkeet/Logistikkakka%20selvitys%20\(en\).pdf](http://www.neli.fi/folders/Files/Hankkeet/Logistikkakka%20selvitys%20(en).pdf) [Viewed 30.9.2013]

Suomen voima. Ajankohtaista. 2013. Available through: <http://www.suomenvoima.fi/fi/ajankohtaista/body0=1046> [Viewed 16.12.2013]

Suomen voima. Ajankohtaista. 2012. Available through: <http://www.suomenvoima.fi/fi/ajankohtaista/body0=443> [Viewed 16.12.2013]

## 8 SUMMARY

The EU GHG emission reduction targets for 2020, 2030 and 2050 play a significant role in promoting renewable energy sources like wind power. As a GHG (greenhouse gas)-free energy production method (excluding the erection and turbine parts), wind power is a compelling choice for fulfilling these future targets. The other EU countries (most notably Denmark and Germany) already have significantly higher wind energy utilization than, for example, in Finland. However, with current state subsidies in Finland, it is likely that this will change in the near future.

Wind power as an energy source is quite compelling when considering the free fuel source. However, the nature of wind causes some difficulties in measuring the quantity of the fuel source and predicting the energy production on a given day. Current top-notch technologies like portable LIDAR and SODAR offer a tempting alternative for laborious mast measurements, and some even predict that there will be a viable online measuring device for the fine-tuning of energy production.

There has been a huge development in wind turbine technology from kilowatt turbines to megawatt turbines. The most notable development has been in turbine structure, and turbine towers are now over 100 meters high with a turbine diameter of 140 meters. Wind turbine generators have also developed from single-speed gearboxed drivetrains to current direct-driven gearboxless drivetrains for increased efficiency. The development of maintenance has also lowered the cost of energy production and increased usability by utilizing modern online measurements for bearing vibrations, oil analysis and temperature measurement. Modern power electronics also utilizes modern automation systems for maximised energy production. Automation also plays a significant role in maximizing the energy production at a given wind speed and ensuring that the quality of electricity fed into grid is acceptable.

Nowadays, most of the challenges of the wind power are caused by public opinion of wind power being noisy and unattractive and legislative issues. However, this criticism has also caused wind turbine manufacturers to develop quieter solutions, and modern direct-driven solutions are

considered to be quite free from mechanical noise. Blade noise is still something of a problem but there has been research into different blade shapes to reduce aerodynamic noise. Government has also done a significant job in mitigating legislative barriers to the wind power construction, but there is still work to be done, especially in simplifying noise regulations. Some are also concerned about wind power being a rather costly energy production method but, with the current technologies and state subsidies, wind power can actually be quite a profitable business. In the future, it is quite likely that the development of wind turbine technology will make wind turbines profitable, even without state subsidies.

The current production subsidy applies to 2,500 MW wind turbines so there is still quite a bit of room for investment possibilities for wind power investors. Current wind power utilization in the tariff system is about 375 MW as of beginning of 2014, which is only 15% of the available tariff. Wind power can be seen as quite a profitable business opportunity, because of state subsidies and highly developed turbine technology.

# PUBLICATIONS OF KYMENLAAKSO UNIVERSITY OF APPLIED SCIENCES

## SERIES B      Research and Reports

- B 1      Markku Huhtinen & al.:  
**Laivadieselien päästöjen vähentäminen olemassa olevissa laivoissa** [1997].
- B 2      Ulla Pietilä, Markku Puustelli:  
**An Empiral Study on Chinese Finnish Buying Behaviour of International Brands** [1997].
- B 3      Markku Huhtinen & al.:  
**Merenkulkualan ympäristönsuojelun koulutustarve Suomessa** [1997].
- B 4      Tuulia Paane-Tiainen:  
**Kohti oppijakeskeisyyttä. Oppijan ja opettajan välisen ohjaavan toiminnan hahmottamista** [1997].
- B 5      Markku Huhtinen & al.:  
**Laivadieselien päästöjä vähentävien puhdistuslaitteiden tuotteistaminen** [1998].
- B 6      Ari Siekkinen:  
**Kotkan alueen kasvihuonepäästöt** [1998]. Myynti: Kotkan Energia.
- B 7      Risto Korhonen, Mika Määttänen:  
**Veturidieseleiden ominaispäästöjen selvittäminen** [1999].
- B 8      Johanna Hasu, Juhani Turtiainen:  
**Terveysalan karusellikoulutusten toteutuksen ja vaikuttavuuden arviointi** [1999].
- B 9      Hilikka Dufva, Mervi Luhtanen, Johanna Hasu:  
**Kymenlaakson väestön hyvinvoinnin tila, selvitys Kymenlaakson väestön hyvinvointiin liittyvistä tekijöistä** [2001].

- B 10 Timo Esko, Sami Uoti:  
**Tutkimussopimusopas** [2002].
- B 11 Arjaterthu Hintsala:  
**Mies sosiaali- ja terveydenhuollon ammattilaisena – minunko ammattini?** [2002].
- B 12 Päivi Mäenpää, Toini Nurminen:  
**Ohjatun harjoittelun oppimisympäristöt ammatillisen kehittymisen edistäjinä – ARVI-projekti 1999-2002** [2003], 2 p. [2005] .
- B 13 Frank Hering:  
**Ehdotus Kymenlaakson ammattikorkeakoulun kestävän kehityksen ohjelmaksi** [2003].
- B 14 Hilikka Dufva, Raija Liukkonen  
**Sosiaali- ja terveysalan yrittäjyys Kaakkois-Suomessa. Selvitys Kaakkois-Suomen sosiaali- ja terveysalan palveluyrittäjyyden nykytilasta ja tulevaisuuden näkymistä** [2003].
- B 15 Eija Anttalainen:  
**Ykköskuski: kuljettajien koulutustarveselvitys** [2003].
- B 16 Jyrki Ahola, Tero Keva:  
**Kymenlaakson hyvinvointistrategia 2003 –2010** [2003], 2 p. [2003].
- B 17 Ulla Pietilä, Markku Puustelli:  
**Paradise in Bahrain** [2003].
- B 18 Elina Petro:  
**Straightway 1996—2003. Kansainvälinen transitoreitin markkinointi** [2003].
- B 19 Anne Kainlauri, Marita Melkko:  
**Kymenlaakson maaseudun hyvinvointipalvelut - näkökulmia maaseudun arkeen sekä mahdollisuuksia ja malleja hyvinvointipalvelujen kehittämiseen** [2005].
- B 20 Anja Härkönen, Tuomo Paakkonen, Tuija Suikkanen-Malin, Pasi Tulkki:  
**Yrittäjyyskasvatus sosiaalialalla** [2005]. 2. p. [2006]
- B 21 Kai Koski (toim.):  
**Kannattava yritys ei menetä parhaita asiakkaitaan. PK-yritysten liiketoiminnan kehittäminen osana perusopetusta** [2005]
- B 22 Paula Posio, Teemu Saarelainen:  
**Käytettävyyden huomioon ottaminen Kaakkois-Suomen ICT-yritysten tuotekehityksessä** [2005]
- B 23 Eeva-Liisa Frilander-Paavilainen, Elina Kantola, Eeva Suuronen:  
**Keski-ikäisten naisten sepelvaltimotaudin riskitekijät, elämäntavat ja ohjaus sairaalassa** [2006]
- B 24 Johanna Erkamo & al.:  
**Oppimisen iloa, verkostojen solmimista ja toimivia toteutuksia yrittäjämäisessä oppimisympäristössä** [2006]

- B 25 Johanna Erkamo & al.:  
**Luovat sattumat ja avoin yhteistyö ikäihmisten iloksi** [2006]
- B 26 Hanna Liikanen, Annukka Niemi:  
**Kotihoidon liikkuvaa tietojenkäsittelyä kehittämässä** [2006]
- B 27 Päivi Mäenpää  
**Kaakkois-Suomen ensihoidon kehittämisstrategia vuoteen 2010** [2006]
- B 28 Anneli Airola, Arja-Tuulikki Wilén (toim.):  
**Hyvinvointialan tutkimus- ja kehittämistoiminta Kymenlaakson ammattikorkeakoulussa** [2006]
- B 29 Arja-Tuulikki Wilén:  
**Sosiaalipäivystys – kehittämishankkeen prosessievaluatio** [2006].
- B 30 Arja Sinkko (toim.):  
**Kestävä kehitys Suomen ammattikorkeakouluissa – SUDENET-verkostohanke** [2007].
- B 31 Eeva-Liisa Frilander-Paavilainen, Mirja Nurmi, Leena Wäre (toim.):  
**Kymenlaakson ammattikorkeakoulu Etelä-Suomen Alkoholiohjelman kuntakumppanuudessa** [2007].
- B 32 Erkki Hämäläinen & Mari Simonen:  
**Siperian radan tariffikorotusten vaikutus konttiliikenteeseen 2006** [2007].
- B 33 Eeva-Liisa Frilander-Paavilainen & Mirja Nurmi:  
**Tulevaisuuteen suuntaava tutkiva ja kehittävä oppiminen avoimissa ammattikorkeakoulun oppimisympäristöissä** [2007].
- B 34 Erkki Hämäläinen & Eugene Korovyakovsky:  
**Survey of the Logistic Factors in the TSR-Railway Operation - "What TSR-Station Masters Think about the Trans-Siberian?"** [2007].
- B 35 Arja Sinkko:  
**Kymenlaakson hyvinvoinnin tutkimus- ja kehittämiskeskus (HYTKES ) 2000-2007. Vaikuttavuuden arviointi** [2007].
- B 36 Erkki Hämäläinen & Eugene Korovyakovsky:  
**Logistics Centres in St Petersburg, Russia: Current status and prospects** [2007].
- B 37 Hilka Dufva & Anneli Airola (toim.):  
**Kymenlaakson hyvinvointistrategia 2007 - 2015** [2007].
- B 38 Anja Härkönen:  
**Turvallista elämää Pohjois-Kymenlaaksossa? Raportti Kouvolan seudun asukkaiden kokemasta turvallisuudesta** [2007].
- B 39 Heidi Nousiainen:  
**Stuuva-tietokanta satamien työturvallisuustyön työkaluna** [2007].



- B 40 Tuula Kivilaakso:  
**Kyminenlaaksolainen veneenveistoperinne: venemestareita ja mestarillisia veneitä** [2007].
- B 41 Elena Timukhina, Erkki Hämäläinen, Soma Biswas-Kauppinen:  
**Logistic Centres in Yekaterinburg: Transport - logistics infrastructure of Ural Region** [2007].
- B 42 Heidi Kokkonen:  
**Kouvola muuttajan silmin. Perheiden asuinpaikan valintaan vaikuttavia tekijöitä** [2007].
- B 43 Jouni Laine, Suvi-Tuuli Lappalainen, Pia Paukku:  
**Kaakkois-Suomen satamasidonnaisten yritysten koulutustarveselvitys** [2007].
- B 44 Alexey V. Rezer & Erkki Hämäläinen:  
**Logistic Centres in Moscow: Transport, operators and logistics infrastructure in the Moscow Region** [2007].
- B 45 Arja-Tuulikki Wilén:  
**Hyvä vanhusten hoidon tulevaisuus. Raportti tutkimuksesta Kotkansaaren sairaalassa 2007** [2007].
- B 46 Harri Ala-Uotila, Eeva-Liisa Frilander-Paavilainen, Ari Lindeman, Pasi Tulkki (toim.):  
**Oppimisympäristöistä innovaatioiden ekosysteemiin** [2007].
- B 47 Elena Timukhina, Erkki Hämäläinen, Soma Biswas-Kauppinen:  
**Railway Shunting Yard Services in a Dry-Port. Analysis of the railway shunting yards in Sverdlovsk-Russia and Kouvola-Finland** [2008].
- B 48 Arja-Tuulikki Wilén:  
**Kyminenlaakson muisti- ja dementiaverkosto. Hankkeen arviointiraportti** [2008].
- B 49 Hilikka Dufva, Anneli Airola (toim.):  
**Puukuidun uudet mahdollisuudet terveyden- ja sairaanhoidossa. TerveysSellu-hanke.** [2008].
- B 50 Samu Urpalainen:  
**3D-voimalaitossimulaattori. Hankkeen loppuraportti.** [2008].
- B 51 Harri Ala-Uotila, Eeva-Liisa Frilander-Paavilainen, Ari Lindeman (toim.):  
**Yrittäjämäisen toiminnan oppiminen Kyminenlaaksossa** [2008].
- B 52 Peter Zashvev, Peeter Vahtra:  
**Opportunities and strategies for Finnish companies in the Saint Petersburg and Leningrad region automobile cluster** [2009].
- B 53 Jari Handelberg, Juhani Talvela:  
**Logistiikka-alan pk-yritykset versus globaalit suuroperaattorit** [2009].
- B 54 Jorma Rytkönen, Tommy Ulmanen:  
**Katsaus intermodaalikuljetusten käsitteisiin** [2009].

- B 55 Eeva-Liisa Frilander-Paavilainen:  
**Lasten ja nuorten terveys- ja tapakäyttäytyminen Etelä-Kymenlaakson kunnissa** [2009].
- B 56 Kirsi Rouhiainen:  
**Viisasten kiveä etsimässä: miksi tradenomiopiskelija jättää opintonsa kesken? Opintojen keskeyttämisen syiden selvitys Kymenlaakson ammattikorkeakoulun liiketalouden osaamisalalla vuonna 2008** [2010].
- B 57 Lauri Korppas - Esa Rika - Eeva-Liisa Kauhanen:  
**eReseptin tuomat muutokset reseptiprosessiin** [2010].
- B 58 Kari Stenman, Rajka Ivanis, Juhani Talvela, Juhani Heikkinen:  
**Logistiikka & ICT Suomessa ja Venäjällä** [2010].
- B 59 Mikael Björk, Tarmo Ahvenainen:  
**Kielelliset käytänteet Kymenlaakson alueen logistiikkayrityksissä** [2010].
- B 60 Anni Mättö:  
**Kyläläisten metsävarojen käyttö ja suhtautuminen metsien häviämiseen Mzuzun alueella Malawissa** [2010].
- B 61 Hilikka Dufva, Juhani Pekkola:  
**Turvallisuusjohtaminen moniammatillisissa viranomaisverkostoissa** [2010].
- B 62 Kari Stenman, Juhani Talvela, Lea Värtö:  
**Toiminnanohjausjärjestelmä Kymenlaakson keskussairaalan välinehuoltoon** [2010].
- B 63 Tommy Ulmanen, Jorma Rytönen:  
**Intermodaalikuljetuksiin vaikuttavat häiriöt Kotkan ja Haminan satamissa** [2010].
- B 64 Mirva Salokorpi, Jorma Rytönen  
**Turvallisuus ja turvallisuusjohtamisjärjestelmät satamissa** [2010].
- B 65 Soili Nysten-Haarala, Katri Pynnöniemi (eds.):  
**Russia and Europe: From mental images to business practices** [2010].
- B 66 Mirva Salokorpi, Jorma Rytönen:  
**Turvallisuusjohtamisen parhaita käytäntöjä merenkulkijoille ja satamille** [2010].
- B 67 Hannu Boren, Marko Viinikainen, Ilkka Paajanen, Viivi Etholen:  
**Puutuotteiden ja -rakenteiden kemiallinen suojaus ja suojauksen markkinapotentiaali** [2011].
- B 68 Tommy Ulmanen, Jorma Rytönen, Taina Lepistö:  
**Tavaravirtojen kasvusta ja häiriötekijöistä aiheutuvat haasteet satamien intermodaalijärjestelmälle** [2011].
- B 69 Juhani Pekkola, Sari Engelhardt, Jussi Hänninen, Olli Lehtonen, Pirjo Ojala:  
**2,6 Kestävä kansakunta. Elinvoimainen 200-vuotias Suomi** [2011].

- B 70 Tommy Ulmanen:  
**Strategisen osaamisen johtaminen satama-alueen Seveso-laitoksissa** [2011].
- B 71 Arja Sinkko:  
**LCCE-mallin käyttöönotto tekniikan ja liikenteen toimialalla – ensiaskeleina tuotteistaminen ja sidosryhmäyhteistyön kehittäminen** [2012].
- B 72 Markku Nikkanen:  
**Observations on Responsibility – with Special reference to Intermodal Freight Transport Networks** [2012].
- B 73 Terhi Suuronen:  
**Yrityksen arvon määrittäminen yrityskauppatilanteessa** [2012].
- B 74 Hanna Kuninkaanniemi, Pekka Malvela, Marja-Leena Saarinen (toim.):  
**Research Publication 2012** [2012].
- B 75 Tuomo Väärä, Reeta Stöd, Hannu Boren:  
**Moderni painekyllästys ja uusien puutuotteiden testaus aidossa, rakennetussa ympäristössä. Jatkohankkeen loppuraportti** [2012].
- B 76 Ilmari Larjavaara:  
**Vaikutustapojen monimuotoisuus B-to-B-markkinoinnissa Venäjällä - lahjukset osana liiketoimintakulttuuria** [2012].
- B 77 Anne Fransas, Enni Nieminen, Mirva Salokorpi, Jorma Rytönen:  
**Maritime safety and security. Literature review** [2012].
- B 78 Juhani Pekkola, Olli Lehtonen, Sanna Haavisto:  
**Kymenlaakson hyvinvointibarometri 2012. Kymenlaakson hyvinvoinnin kehityssuuntia viranhaltijoiden, luottamushenkilöiden ja ammattilaisten arvioimana** [2012].
- B 79 Auli Jungner (toim.):  
**Sosionomin (AMK) osaamisen työelämälähtöinen vahvistaminen. Ongelmaperustaisen oppimisen jalkauttaminen työelämäyhteistyöhön** [2012].
- B 80 Mikko Mylläri, Jouni-Juhani Häkkinen:  
**Biokaasun liikennekäyttö Kymenlaaksossa** [2012].
- B 81 Riitta Leviäkangas (toim.):  
**Yhteiskuntavastuuraportti 2011** [2012].
- B 82 Riitta Leviäkangas (ed.):  
**Annual Responsibility Report 2011** [2012].
- B 83 Juhani Heikkinen, Janne Mikkala, Niko Jurvanen:  
**Satamayhteisön PCS-järjestelmän pilotointi Kaakkois-Suomessa. Mobiilisatama-projektin työpaketit WP4 ja WP5, loppuraportti 2012** [2012].

- B 84 Tuomo Väärä, Hannu Boren:  
**Puun modifiointiklusteri. Loppuraportti 2012** [2012].
- B 85 Tiina Kirvesniemi:  
**Tieto ja tiedon luominen päiväkotityön arjessa** [2012].
- B 86 Sari Kiviharju, Anne Jääsmaa:  
**KV-hanketoiminnan osaamisen ja kehittämistarpeiden kartoitus - Kyselyn tulokset** [2012].
- B 87 Satu Hoikka, Liisa Korpivaara:  
**Työhyvinvointia yrittäjälle - yrittäjien kokemuksia Hyvinvointikoulusta ja näkemyksiä yrittäjän työhyvinvointia parantavista keinoista** [2012].
- B 88 Sanna Haavisto, Saara Eskola, Sami-Seppö Ovaska:  
**Kopteri-hankkeen loppuraportti** [2013].
- B 89 Marja-Liisa Neuvonen-Rauhala, Pekka Malvela, Heta Vilén, Oona Sahlberg (toim.):  
**Sidos 2013 - Katsaus kansainvälisen liiketoiminnan ja kulttuurin toimialan työelämäläheisyyteen** [2013].
- B 90 Minna Söderqvist:  
**Asiakaskeskeistä kansainvälistymistä Kymenlaakson ammattikorkeakoulun yritysysteistyössä** [2013].
- B 91 Sari Engelhardt, Marja-Leena Salenius, Juhani Pekkola:  
**Hyvän tuulen palvelu. Kotkan terveystioski hyvinvoinnin edistäjänä - Kotkan terveystioskikokeilun arviointi 2011-2012** [2013].
- B 92 Anne Fransas, Enni Nieminen, Mirva Salokorpi:  
**Maritime security and safety threats – Study in the Baltic Sea area** [2013].
- B 93 Valdemar Kallunki (toim.):  
**Elämässä on lupa tavoitella onnea: Nuorten aikuisten koettu hyvinvointi, syrjäytyminen ja osallisuus Kaakkois-Suomessa ja Luoteis-Venäjällä. Voi hyvin nuori -hankkeen loppuraportti.** [2013].
- B 94 Hanna Kuninkaanniemi, Pekka Malvela, Marja-Leena Saarinen (toim.):  
**Research Publication 2013** [2013].
- B 95 Arja Sinkko (toim.):  
**Tekniikan ja liikenteen toimialan LCCE-toiminta Yritysysteistyönä käytännössä: logistiikan opiskelijoiden "24 tunnin ponnistus"**[2013].
- B 96 Markku Nikkanen:  
**Notes & Tones on Aspects of Aesthetics in Studying Harmony and Disharmony: A Dialectical Examination** [2013].
- B 97 Riitta Leviäkangas (toim.):  
**Yhteiskuntavastuuraportti 2012** [2013].

- B 98 Mervi Nurminen, Teija Suoknuuti, Riina Mylläri (toim.):  
**Sidos 2013, NELI North European Logistics Institute - Katsaus logistiikan kehitysohjelman tuloksiin**[2013].
- B 99 Jouni-Juhani Häkkinen, Svenja Baer, Hanna Ricklefs:  
**Economic comparison of three NO<sub>x</sub> emission abatement systems** [2013].
- B 100 Merja Laitoniemi:  
**Yksinäisyydestä yhteisöllisyyteen. Yhteisöllistä hoitotyötä Elimäen Puustellissa** [2013].
- B 101 Kari Stenman (toim.):  
**ROCKET. Kymenlaakson ammattikorkeakoulun osahankkeen loppuraportti** [2013].
- B 102 Hannu Sarvelainen, Niko Töyrylä:  
**Koelaite biomassan torrefiointiin. Biotuli-hankkeen tutkimusraportti 2013** [2013].
- B 103 Saara Eskola:  
**Biotuli-hanke. Puupohjaiset antibakteeriset tuotteet infektioiden torjunnassa** [2013].
- B 104 Hilikka Dufva, Juhani Pekkola:  
**Matkustajalaivaliikennettä harjoittavan varustamon yhteiskuntaeettinen liiketoiminta** [2013].
- B 105 Mirva Pilli-Sihvola (toim.):  
**Muuttuuko opettajuus ja mihin suuntaan? Yhteisöllisen verkko-oppimisen ja mobiilioppimisen mahdollisuuksia etsimässä** [2013].
- B 106 Anne Fransas, Enni Nieminen, Mirva Salokorpi:  
**Maritime security and security measures – Mimic Study in the Baltic Sea Area** [2013].
- B 107 Satu Peltola (ed.):  
**Wicked world – The spirit of wicked problems in the field of higher education** [2013].
- B 108 Hannu Sarvelainen, Niko Töyrylä:  
**Erialaisten biomassojen soveltuvuus torrefiointiin. BIOTULI-hankkeen tutkimusraportti 2013** [2013].
- B 109 Tiina Kirvesniemi:  
**Ammattikorkeakouluopintoihin valmentava koulutus maahanmuuttajille – kokemuksia Kymenlaaksossa** [2013].
- B 110 Jari Hyyryläinen, Pia Paukku ja Emmi Rantavuo  
**Trik-hanke. Kotka, Kundan ja Krostadtin välisen laivareitin matkustaja- ja rahtipotentiaalin selvitys.** [2013].
- B 111 Heta Vilén, Camilla Grönlund (toim.)  
**LCCE-harjoittelu. Harjoitteluprosessi osana LCCE-konseptia** [2013].
- B 112 Kati Raikunen, Riina Mylläri  
**Kaakkois-Suomen logistiikkakatsaus** [2014].



**KYAMK**  
University of Applied Sciences