



**Universidad de Valladolid**



**ESCUELA DE INGENIERÍAS  
INDUSTRIALES**

**UNIVERSIDAD DE VALLADOLID**

**ESCUELA DE INGENIERIAS INDUSTRIALES**

**Building services engineering**

**VENTILATION AND INDOOR CLIMATE IN A  
NEW BUILDING IN FINLAND**

**Autor:**

**Ossi Valto**

**Tutor:**

**Javier Maria Rey Hernandez**

**Valladolid, May 2018**

## ABSTRACT

University of Valladolid  
Building Service Engineering  
HVAC

VALTO OSSI:

Ventilation and indoor climate in a new building in Finland

Bachelor's thesis 124 pages

May 2018

---

This Bachelor's thesis deals with the implementation methods of ventilation, the regulations adopted for this purpose as well as the implementation methods and regulations for a good indoor climate in a new building in Finland. The implementation methods of ventilation and their suitability for different situations are explained in general. About the indoor climate, the thesis presents factors influencing the quality of indoor climate and the impacts of these factors to people and to peoples' well-being.

The thesis deals technologies used in field of ventilation. Writing tells about air handling units, its various parts and applications and air distribution methods and devices.

Data collection mainly took place through printed literature, a variety of regulations and standards. Regulation and instructions were mainly collected from *Sisäilmastoluokitus 2008* RT-card and the Ministry of Environment decrees.

As a result, it was established that ventilation and indoor climate is a diverse and demanding field of technical building services. It also has a major importance for residential comfort in a building.

---

Descriptors: ventilation, indoor climate, indoor air quality

## TABLE OF CONTENTS

1	SUMMARY .....	5
2	OBJECTIVE.....	6
2.1	National laws and regulations.....	7
3	INDOOR CLIMATE.....	18
3.1	Indoor air quality .....	19
	Particles and fibres .....	23
	Gaseous pollutants .....	25
	Supply air filtration.....	28
3.2	Thermal comfort.....	29
	Operative temperature .....	30
	Air movement and draught.....	35
	Humidity in ventilation .....	38
3.3	Sound and noise .....	41
4	VENTILATION .....	45
4.1	Air flows .....	48
	Determination of air flow rates .....	50
	Calculation based on impurity load .....	51
	Calculation based on thermal load.....	53
	Determination based on the guidelines.....	55
	Extract air classes .....	65
	Positioning of fresh air and exhaust devices .....	65
	Distribution and extraction of air .....	68
	Recirculated air, transferred air and circulated air .....	69
4.2	Ductwork.....	70
	Ducts .....	73
	Duct components.....	76
	Insulations .....	77
	Supporting.....	78
5	TECHNOLOGY.....	80
5.1	Air handling unit .....	80
	Small air handling units.....	81
	Enclosed air handling units.....	81
	Operational air handling units.....	82

Separated fans.....	82
5.2 Functioning parts of air handling unit .....	85
Air heater and air cooler .....	85
Heat recovery .....	86
Fans .....	92
5.3 Air distribution methods .....	95
Air conditioning strategy .....	96
Extraction strategies .....	102
Variable air volume system (VAV) .....	104
Chilled beam .....	107
Air distribution and extraction devices .....	109
Air diffusion .....	112
6 EXAMPLE .....	116
7 CONCLUSION .....	124
8 BIBLIOGRAPHY.....	125

## 1 SUMMARY

I'm studying building service engineering at Tampere University of Applied Sciences and I completed an exchange program in Valladolid, Spain, in the autumn semester of 2017. During the exchange I studied at University of Valladolid, where I also did this thesis. The purpose of the thesis is to describe the functioning ventilation and good indoor climate in Finland and how to reach them.

In Finland the technical building services is highly valued in the construction of a building. Without it, is impossible to keep the building healthy, functional and long living under Finland's harsh and varying conditions. Particularly important is the ventilation of the building and the indoor climate. Under Finnish conditions, buildings are built to be really thigh and to have a thick insulation, whereby ventilation and indoor climate are further emphasized.

Ventilation and air conditioning systems in buildings have developed strongly since the early 2000s. The need of cleaner and more energy efficient systems is constantly increasing. Currently, the direction of development is going towards Nearly zero-energy buildings. In Finland, all new buildings of public-sector must meet the Nearly zero-energy building requirements by year 2021.

The thesis deals with a lot of ventilation and indoor climate basis on point of view of regulations and instructions given in Finland and how the regulations and instructions are affecting to implementation of the ventilation systems and the indoor climate in the buildings.

## 2 OBJECTIVE

Objective of the thesis is to introduce used implementation and planning methods of ventilation and associated operations in Finland, and indoor climate and affecting factors to its quality and what should be considered while planning and implement it. The thesis focusses on regulations and instructions given to ventilation and indoor climate in Finland. These regulations and instructions presents target values of factors effecting to ventilation and indoor climate and implementation methods to guarantee good and functioning ventilation and indoor air quality. The thesis introduces also machineries and applications used in ventilation technology and these purposes of use.

The role of HVAC engineer is to create good air quality and heating conditions in buildings. The HVAC engineer should consider following things:

- Heating – process or room heating energy need in relation to heat losses
- Cooling – removing overheat of the spaces or process in relation to the resulting thermal loads
- Humidification – adding water or water vapor to maintain the humidity conditions required by the process or spaces
- Dehumidification – removing water vapor to maintain the humidity content of the process or spaces
- Filtration – removal of particulate and bio contaminants from the air-conditioned space
- Ventilation – import of suitable outdoor air flow rate to maintain air quality and control the pressure conditions of the building
- Efficiency – transfer of necessary energy, humidity monitoring, filtration and ventilation in the occupied zone

One of the main points are still to accomplish functioning and healthy indoor climate for the people, which is reducing health risks, increasing productivity and save the environment.

## 2.1 National laws and regulations

Various regulations and instructions have been issued for implementation of ventilation and good indoor climate. The regulations and instructions can be divided following by them legitimacy:

- Regulations which always holds without allusion
  - Laws
  - Decree
  - Ministerial decision
- Regulations which holds when allude to them
  - Ministry instructions
- Goof construction method which holds when allude to it
  - SFS-standard
  - Technical building services RYL (TalotekniikkaRYL)
- Sources of information which helps planning but have no binding status
  - HVAC register
  - Manuals, books

Below is presented some of the most important documents of ventilation technology and their content. The use of these documents is common implementation of ventilation and good indoor climate.

## **Land use and construction law (fin. Maankäyttö- ja rakennuslaki (MRL; 132/1999))**

Land use and construction law is concerning usage of areas and constructions. Objective is to create healthy, safety and comfortable environment, what is practical and takes note of different population groups. Construction of building needs a planning permission. Land use and construction law defines what is not a building. Law doesn't consider construction as a building, if the structure is small and lightweight, and it's not effecting to use of land or environment. The planning permission is also needed if renovation or modification works are compared to construction of a building, extending of a building or enlarging counted floor area.

## **Finland's construction regulation collection (fin. Suomen rakentamismääräyskokoelma)**

Land use and construction law defines general prerequisite of construction, essential technical requirements, and authorization and official supervision. More precise regulations and instructions are collected in Finland's construction regulation collection. Construction regulations are given by Ministry of the Environment's decree. Given and collected decrees in the Finland's construction regulation collection are binding. Instructions given by Ministry instead are not binding.

Construction regulation collection is divided in the parts, which are grouped by the contents. For the ventilation and indoor climate, the most essential parts are:

- Planning and supervision, Decree of the Government on the determination of demand categories for construction planning tasks (old A2 Planners and plans of buildings)



- Noise prevention and sound conditions, Decree of the Ministry of the Environment on the sound environment of the building (old C1 Soundproofing and noise prevention in a building)
- Healthiness, Decree of the Ministry of the Environment on the indoor air climate and ventilation of a building (old D2 Indoor climate and ventilation of buildings)
- Energy efficiency, Decree of the Ministry of the Environment on the energy efficiency of a new building (old D3 Energy efficiency of buildings)
- Energy efficiency, Instruction of the Ministry of the Environment on the heating power and energy requirement calculations of buildings (old D5 Heating power and energy requirement calculations of buildings)

The Finland's construction regulation collection has been under radical changes during the last years. The new regulations took effect on the year 2018. The changes have greatly influenced the structure of the collection and the designation of parts. The key objective of the reform is the clarity of the regulation on construction and the unity and predictability of its application. In the context of the reform, regulation was also reduced.

From the point of view of the ventilation and the determination of air flow rates, the major changes came to the old regulation *D2 indoor climate and the ventilation in the building*, whose air flow rate determination tables in the appendices were widely used in dimensioning the air flow rates of many buildings and spaces. At present, the indicative determination tables for air flow rates cannot be found as a decree, but a separate instruction.

Air flow determination guidelines were updated in the research during 2017. The update was based expert assessments, international standards and latest research data. Some refinement and improvement need arose in the review of tables' updating needs. Particularly important was the control and use of air exchange according to the actual need (impurity load and utilization rate of

space). In the survey, the ventilation of many spaces seemed unnecessarily big. Below are presented some thoughts about the spaces whose ventilation was considered unnecessarily big:

- Residential buildings
  - Too big air flow rate in small residential buildings, if dimensioning accords to extract air flow rates
  - Should ventilation of bedroom be dimensioned for 1 or 2 persons?
  - Laundry room: is 10 dm<sup>3</sup>/s enough?
  - Is air flow rate of sauna too big?
- Total air flow rate of day cares grows unnecessarily big, if ventilation of every room is dimensioned like there is always the maximum utilization rate
- Air flow rate (10 dm<sup>3</sup>/s)/m<sup>2</sup> for restaurants is usually too big. Restaurants should be divided more accurately, for example cafeterias (3 dm<sup>3</sup>/s)/m<sup>2</sup>, pizzerias (6 dm<sup>3</sup>/s)/m<sup>2</sup> etc.
- Stores – air flow rates are usually too big. Old (2 dm<sup>3</sup>/s)/m<sup>2</sup> was proposed to lower on half.

The ventilation of the following premises was considered too small:

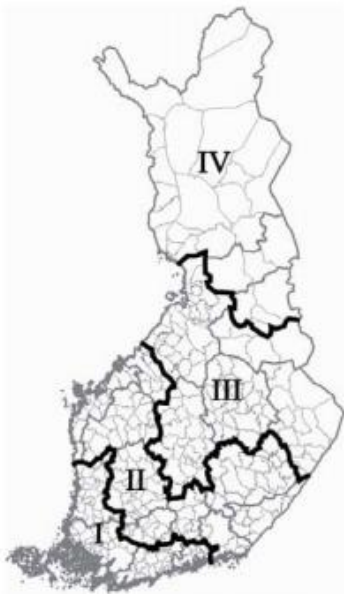
- Gyms
- Guideline value 20 dm<sup>3</sup>/s for cooker hoods in residential buildings
- Elderly service houses
- Operating rooms in hospitals
- Educational spaces in schools

The following premises were desired to be added or the specification to be changed compared to the old regulation:

- Particularly smell and impurity loaded spaces such as barbers and pet shops
- Electricity, electronic and IT rooms
- Pool areas
- Restaurants divided more specifically

Examples for air flow rates of some different spaces are presented in **tables 4.1** and **4.2, 4.3** and **4.4**.

In Finland, temperatures can be very different in various parts of the country. Therefore, Finland is divided into four different weather zones. The weather zones are used to planning of room temperature control. The planning of room temperature control is based on dimensioning outdoor air temperatures presented in **table 2.1** and on more precisely presented weather conditions, which can be found in the *indoor air climate and ventilation of a building* regulation. The dimensioning outdoor air temperatures are required for example, for dimensioning air handling unit. Finland is divided to four weather zones according to predetermination of the coldest outdoor air temperatures in the year. These weather zones are presented in **figure 2.1**.



**Figure 2.1.** Weather zones (Ympäristöministeriö, 2017)

**Table 2.1.** Dimensioning outdoor air temperatures

<b>Weather zone</b>	<b>Dimensioning outdoor air temperatures, °C</b>
I	-26
II	-29
III	-32
IV	-38

## Standards

Standard is a consistent solution for a recurring case. In other words, the standard is a written description of a good prevailing practice. (Seppänen, 2014)

Standardization includes products, systems, services, planning and terminology standards. The standards apply almost entirely to Europe or the entire world. Significant official standardization organizations are international ISO and IEC, European CEN and CENELEC, German DIN and Finnish SFS.

The standards are intended to benefit the whole society. The standards allow that the repetitive things are not must thought every time from the beginning again. In construction and hence in building services, with the exception of the manufacturing industry, the use of standards has been less than in field of electronics and mechanical technology.

## Indoor climate classification 2008 (fin. Sisäilmastoluokitus 2008)

Indoor climate classification is classified to three different classes for support inspecting, measuring and classification of spaces in buildings. The three classes are designated to indoor climate class S1, S2 and S3. Every class has their own guideline values, for example for the operative temperature, indoor air quality and voice levels.

The guideline values of indoor climate class are attempted to set, such that class S3 matches with requirements of land use and construction law and health protection law (fin. terveydensuojelulaki). According to current knowledge, when the target values for class S3 will be fulfilled, it will not cause any health problems to healthy persons, if ventilation of the building is functioning as planned and there not any particular impurity sources. (Sisäilmastoluokitus 2008)

In the indoor climate classification, the class S1 is the best, which means larger satisfaction of users. Setting the target helps cooperation between different operators and so is reducing problems of health and well-being. The classifications are defined as follows:

#### S1: Individual indoor climate

Indoor air quality of space is very good and neither has any noticeable smells. Spaces and structures interrelate with indoor air, doesn't have any damages or impurity sources, which could impair the indoor air quality. Temperatures are comfortable and neither exist draught or overheating. User of the space can individually control temperatures. Spaces have very good voice conditions for purpose of use and individually controlled good lightning conditions.

#### S2: Good indoor climate

Indoor air quality of space is good and neither has any distracting smells. Spaces and structures interrelate with indoor air doesn't have any damages or impurity sources, which could impair the indoor air quality. Temperatures are good and usually draught doesn't exist. Overheating can be possible on hot summer days. Spaces have good voice and lightning conditions for purpose of use.

### S3: Acceptable indoor climate

Indoor air quality and temperatures, and voice and lighting conditions of space are answering the minimum requirements of the Finland's construction regulation collection.

Target and planning values of different quantities could be chosen from different classes. If needed, some value of quantity can be defined case-specific.

The indoor climate classification also includes the following classifications of cleanliness of materials and equipment:

- Cleanliness classification of ventilation system
- Emission classification of building materials
- Cleanliness classification of ventilation products

The purpose of the cleanliness classification of ventilation system is to ensure the good quality of supply air flowing through new ventilation system. The good quality supply air must not contain substances or smells harmful to the health or the comfort caused by the ventilation system.

Two cleanliness classes P1 and P2 are used for determinate the cleanliness of new ventilation system. The filters to be used must meet cleanliness class M1 requirements for ventilation products. The requirements of cleanliness classes are presented in **tables 2.2** and **2.3**.

**Table 2.2.** Requirements of cleanliness class P1

<b>Requirements of cleanliness class P1</b>
Supply air ducts and duct parts are made of cleanliness classified ventilation products or on building site at a similar class of cleaned products.
Sealing materials are classified to building material class M1 or M2 or otherwise low emission known materials.
Average dust concentration on the inner surface of ventilation system shall not be more than 0,7 g/m <sup>2</sup> measured by the filter method or visually assessed.
In building, returned air is not used with the exception of only one room or an apartment serving air handling unit.
Using fragrances in supply air is forbidden.
Two-stage filtering is installed on supply air side of air handling units, the filtering level corresponding to the requirements of table 2.

**Table 2.3.** Requirements of cleanliness class P2

<b>Requirements of cleanliness class P2</b>
Supply air ducts and duct parts are made of cleanliness classified ventilation products or on building site at a similar class of cleaned products.
Average dust concentration on the inner surface of ventilation system shall not be more than 2,5 g/m <sup>2</sup> measured by the filter method or visually assessed.
Building can use returned air from similar spaces with equal cleanliness. The returned air must be filtered by supply air filter corresponding to the filter of cleanliness class.
Using fragrances in supply air is forbidden.
Two-stage filtering is installed on supply air side of air handling units, the filtering level corresponding to the requirements of table 2.

**Table 2.4** Filtration class with relation to cleanliness class

	<b>S1</b>	<b>S2</b>	<b>S3</b>
Filtration class	F8	F7	F6
Cleanliness class	P1	P1	P2

Building and decorating materials release a variety of chemicals into the room air. They may originate from used raw materials, errors in the manufacturing process or aging of the materials or may result from misuse of the materials. The room air concentration is determined by the total emissions of materials and ventilation. To minimize pollutant concentrations, it will primarily have to affect total emissions by using low emission materials and only in the alternative by increasing ventilation.

The emission classification of building materials is primarily designed to classify materials that are common in residential and work rooms. The emission classification of building materials is three-tier so that the class M1 is the best and the class M3 is the most polluting. For the best indoor climate classes S1 and S2, the use of class M2 and M3 materials should be restricted.

Class M1 includes emission-tested materials whose emissions meet the requirements of **table 2.5**. Class M2 includes emission-tested materials whose emissions meet the requirements of **table 2.6**. Class M3 includes materials which emissions exceed M2 requirements. Unclassified materials are not assigned with rating mark.

**Table 2.5.** Requirements of class M1

<b>Class M1</b>
The overall emission of volatile organic compounds (TVOC) is less than 0,2 mg/m <sup>2</sup> h. At least 70 % of the compounds must be identified.
Emission of formaldehyde (H <sub>2</sub> CO) is below 0,05 mg/m <sup>2</sup> h.
Emission of ammonia (NH <sub>3</sub> ) is below 0,03 mg/m <sup>2</sup> h.
Emissions of category 1 carcinogenic substances classified as IARC are below 0,005 mg/m <sup>2</sup> h.
The material does not smell, the smell acceptable for the uneducated panel is estimated to be 0,1.
Mortars, screeds and putties must not contain casein.



**Table 2.6.** Requirements of class M2

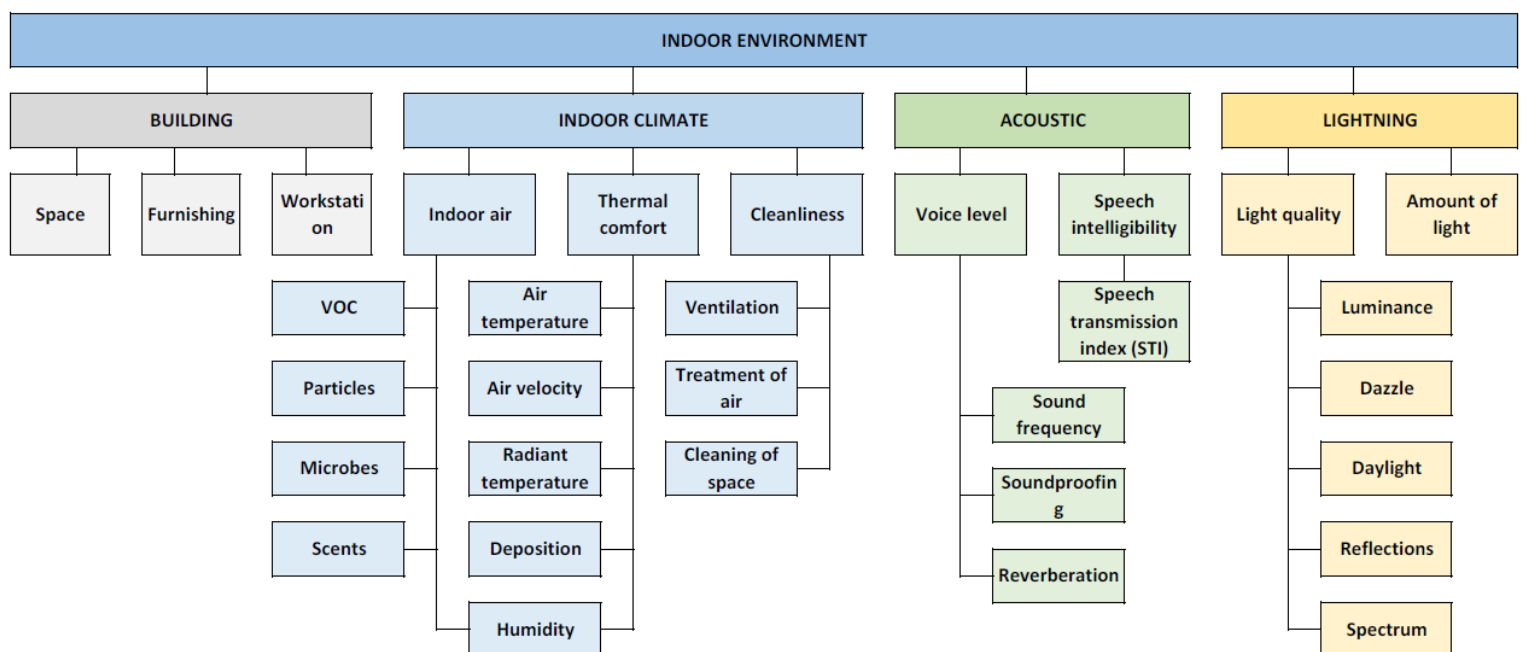
<b>Class M2</b>
The overall emission of volatile organic compounds (TVOC) is less than 0,4 mg/m <sup>2</sup> h. At least 70 % of the compounds must be identified.
Emission of formaldehyde (H <sub>2</sub> CO) is below 0,125 mg/m <sup>2</sup> h.
Emission of ammonia (NH <sub>3</sub> ) is below 0,06 mg/m <sup>2</sup> h.
Emissions of category 1 carcinogenic substances classified as IARC are below 0,005 mg/m <sup>2</sup> h.
The material does not smell, the smell acceptable for the uneducated panel is estimated to be 0,1.
Mortars, screeds and putties must not contain casein.

There is only one cleanliness class for ventilation products. The part of the ventilation system is therefore either cleanliness classified or not. The following are the general requirements for the cleanliness classified ventilation products:

- Cleanliness classified ventilation product must not add any harmful impurities to the health or comfort of the ventilation system or supply air
- Cleanliness classified ventilation product must not produce smell or gaseous or particulate pollutants impairing the indoor air quality
- Cleanliness classified ventilation product must be easily cleanable

### 3 INDOOR CLIMATE

Indoor climate is a term which refers physical, chemical and microbiological factors effecting to human health and well-being in a building. Usually these factors are divided to thermal comfort and indoor air quality. Commonly is used term called indoor environment, which in addition to previous, encompass also acoustic and lighting circumstance, and space planning.



**Figure 3.1.** Factors affecting the definition of the indoor environment

The most important indoor climate factors relative to ventilation are thermal comfort, indoor air quality and sound level of ventilation systems. This chapter describes the general issues of these factors and presents the targets related to the factors.

### 3.1 Indoor air quality

People spend about 90 % of their time indoors and inhale daily from 15 m<sup>3</sup> to 20 m<sup>3</sup> of indoor air. Therefore, for the people the indoor air quality is more important than the outdoor air quality. Bad indoor air quality causes in every year about one billion euros extra costs in the shape of sick leaves and medical costs in Finland. Lacks and problems in the indoor climate affects fundamentally for people's comfort, healthy and work efficiency. Effects of impurities and other harmful factors of indoor climate for people are complicated occurrence. Effects depend on many factors: person's health, age, sensitivity, exposure time, other loads etc. Because of this, absolutely sure limiting values is very hard to set.

People can also tolerate harsh conditions, if they have enough motivation and otherwise the conditions are very good. For example, workplace's good spirit or big salary can help for tolerating bad indoor climate conditions. However, this situation can't be considered desirable as it will cause constant hidden loads and health risks. Because of this, indoor climate conditions should be never let to be such bad, that it's going to cause health problems for the people. Especially in the spaces where children, elderly person and patients are staying, indoor climate should be kept constantly good.

Indoor climate effects people in many ways. Commonly indoor climate effects to skin, mucous membrane and airways. The desirable situation can be considered, where indoor climate contributes positively to the health and comfort of the person.

The temperature deviation from the ideal value, causes first a discomfort which increases as the deviation increases. If the deviation continues growing, it strains the human body so that it will influence on health. Continuous and prolonged discomfort can cause also health harms. The feeling of discomfort demands that a person senses that factor, for example as smell or draught. For many impurities, this so-called smell threshold is however so high that the unhealthy effects of the impurities are taking effects before they have been felt a

discomfort. Especially, this is the case for many mixtures of chemical substances in room air. Some of impurities people do not sense at all and the contents can be very high without any sensations. Typical, this kind of impurity is radioactive radon.

People are sensing differently indoor climate problems. Similar conditions are not causing always similar reactions. Therefore, individual adjustment possibility is important for the people's well-being. On last years has come up a sick building problem. Problem is a result from indoor climate problems. The sick building problem causes sick building symptoms, which are indefinable by nature. Typically, person senses symptoms while staying in the sick building and not while staying outdoor or in a healthy building. WHO (World Health Organization) defines the sick building symptoms on following way:

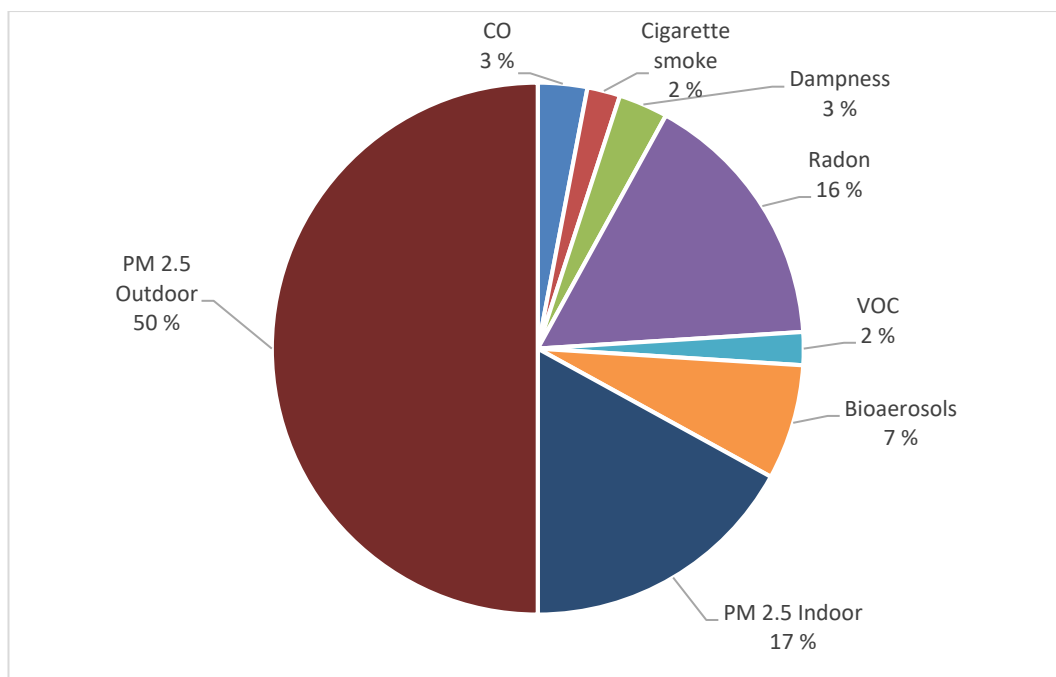
- Irritation of nose, eyes or throat
- Dry mucous membrane or skin
- Redness of skin
- Mental tiredness or headache
- Respiratory tract infection and cough
- Raspy voice
- Hyperergia reactions
- Nausea or dizziness

These symptoms, which are quite common and can be results of many reasons, are considered as sick building symptoms if symptoms disappear or relive when leaving the building and get stronger when returned in the building.

The sick building symptoms have often been used as a measure of human health or morbidity in health-related research. The prevalence of sick building symptoms has been reported to be related to high room temperature, dusty room, high concentration of certain organic compounds, a low air flow rate and air conditioning (for example, Seppänen ym. 1999, Seppänen ja Fisk 2002).

Almost all the studies found that the risk increased with a ventilation of less than  $10 \text{ dm}^3/\text{s}$  per person. They also showed that ventilation up to  $20 \text{ dm}^3/\text{s}$  often reduced the prevalence of illness and improved air quality. Several studies also showed a dose-response relationship between the prevalence of symptoms and the rate of ventilation up to air flow rate  $25 \text{ dm}^3/\text{s}$  per person, meaning the symptoms decreased as the amount of ventilation increased. In almost all studies, it was found that with ventilation less than  $10 \text{ dm}^3/\text{s}$  per person, the negative health effects were statistically significant and the air quality deteriorated (Sandberg, 2014).

Pollutant emissions in indoor air vary by time, affected by human activity and many circumstantial factors. Some typical impurity sources and other factors affecting to air quality and their incidence rates are illustrated in **figure 3.2**.



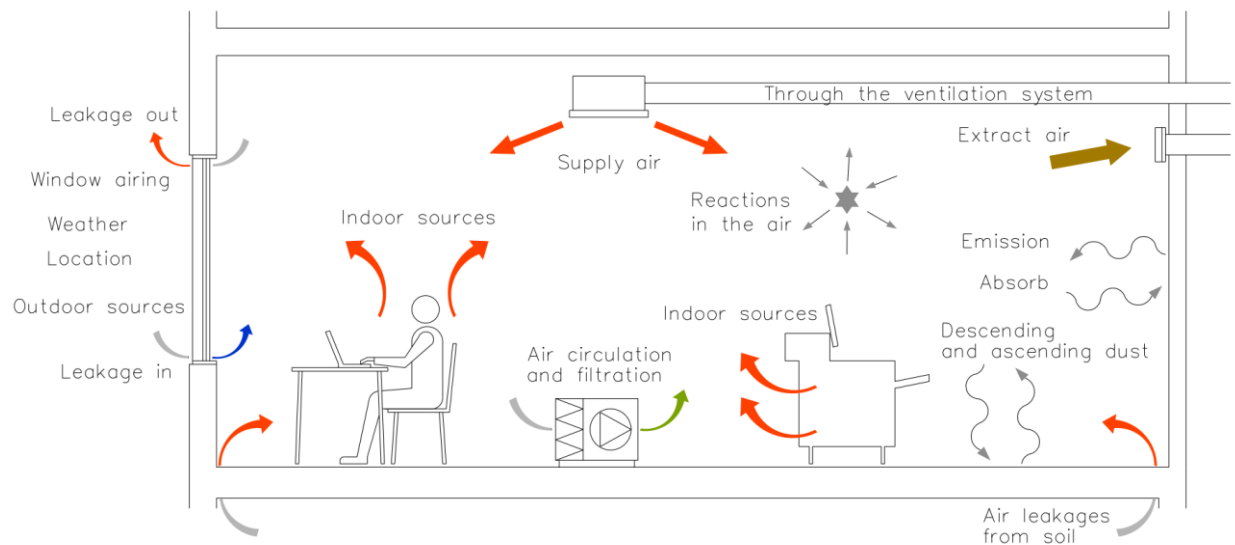
**Figure 3.2.** Typical impurity sources and factors affecting to air quality and their incidence rates (Hänninen, 2013)

Building and furnishing materials are sources of many pollutants. The classification of building materials used in Finland has managed to significantly reduce these emissions. Moisture during the construction or wetting of the material,

for example in the event of water injury, may increase emissions and cause health hazards. Different impurities can also be adsorbed to the materials which, when released again, cause air quality deterioration. For example, cigarette smoke strongly adheres to soft and fibrous materials and subsequently causes a strong undesirable scent.

Many pollutants come from outdoors, people or other activities that are closely related to the use of the premises. In this situation the elimination of pollutants is not possible, but ventilation, filtering and other means must be used. The quality of the room air can also be improved by many building design, construction and furniture related methods. In the prevention against impurities, the main focus should be on removing and reducing pollutant sources, since the dimensioning of ventilation to remove all pollutants is neither sensible nor economical.

Pollution concentrations and their limit values can and should be used when considering whether the indoor air quality meets the criteria set for it. However, these limit values exist only for a few pollutants (see **tables 3.2** and **3.3**), so the fulfilment of known limit values will not guarantee a healthy indoor air. However, in general the values are fulfilled if ventilation is functioning as its planned and there are no special impurity sources in the room. Measurement of indoor air contaminants is therefore only necessary in particular cases.



**Figure 3.3.** Impurity sources of indoor air

### Particles and fibres

The particles are classified according to their size. Large particles are larger than 10 micrometres, while less than 10 micrometres are called respirable particles. The largest respirable particles are called coarse (size 2,5  $\mu\text{m}$  to 10  $\mu\text{m}$ ) and smaller to small particles (diameter less than 2,5  $\mu\text{m}$ ) or nanoparticles (diameter less than 0,1  $\mu\text{m}$ ). The airborne dust of room air consists of particles of varying size that descend more slowly, the smaller they are. In practise, particles less than 5  $\mu\text{m}$  diameter will not land, but move along with the air flow.

The adverse health effects of the particles result from their ability to penetrate through the airways to the bloodstream. Small particles can consist of toxic compounds or carry them in solid, liquid or gas phases. In addition to the composition, their health effects depend on the site of attachment in the respiratory organs.

Small particles are generated from activities take place indoors. The rooms where people smoke, smoking is the most significant source of particles in terms of the number of particles. Other sources include pets, cooking, skin,

clothing, stationery, furnishing textiles and surface sheets. However, mainly the small particles of the indoor air originate from the outside. Significant outdoor sources of particles are transport, industry, heat and power generation, and plant pollens.

Health effects can be reduced by supply air filtration or air cleaners. Reducing exposure to outdoor particles reduces the risk of heart disease, which has a significant public health significance. Good air cleaning also reduces allergies and asthma symptoms, especially in homes with pets.

In the assessment of particles, the mass of particles with less than 2,5 micrometres diameter is generally used (PM<sub>2,5</sub>). Guideline values for the particle concentrations of indoor and outdoor air is presented in **table 3.1**.

**Table 3.1.** Particle concentrations of indoor and outdoor air

	PM <sub>10</sub> (µg/m <sup>3</sup> )	PM <sub>2,5</sub> (µg/m <sup>3</sup> )
<b>Concentration of outdoor air</b>		
WHO's guideline value of air quality (yearly average)	20	10
WHO's guideline value of air quality (24 h average)	50	25
Finland, guideline value of particle concentration	40	25
HSY's air quality index (1 h average)	20	10
<b>Concentration of indoor air</b>		
Old construction regulation collection part D2	50	-
Old indoor climate classification 2000	20	-

The particle concentration of apartments and premises with supply air filtration is generally lower than presented limit values. However, high concentrations are expected, especially when the rooms have a high person density, there is smoked or there are handled plenty of paper or other dusty material. For example, in school rooms have been measured clearly higher concentrations.

Fibrous materials are mainly used for thermal insulation of structures, pipelines and ducts. The most common fibrous building materials include mineral wools



such as rock wool, glass wool etc. Nowadays, problems are caused by in 1960s and 1970s much used asbestos, which is currently forbidden in any kind of use, due to the dangers of the particles released by it. Problems arise in refurbishment sites where dismantling insulations are made of asbestos, which releases asbestos fibres when broken. Asbestos removal is always carried out by a specialized company.

The dangers of asbestos fibres are due to the fact that when inhaled to lungs, it stays there and does not get out like many other particles. At high doses in lungs, asbestos fibres cause asbestosis, which can develop lung cancer. According to the Government's decision, the maximum permitted asbestos concentration in air of workplace is 0,01 fibres/cm<sup>3</sup>.

The effect of inorganic fibres such as mineral wools may cause stronger feel than asbestos fibres. This is because their concentration is generally higher than of asbestos fibres and that the fibres irritate the skin and upper respiratory tract, causing rhinitis, cough and eye irritation. However, inorganic fibres do not cause permanent lung changes and dissolves without causing harm.

### **Gaseous pollutants**

The indoor air quality is influenced by several gaseous pollutants. The impurities come from people, indoor and outdoor sources, materials and soil. The most common gaseous pollutants affecting indoor air quality are:

- Carbon dioxide
- Nitric oxide
- Carbon monoxide
- Ozone
- Radon
- Formaldehyde

The main source of carbon dioxide indoors is exhaled air. In light work, the output of a metabolic carbon dioxide is about 20 dm<sup>3</sup>/h in medium-sized people at rest, while in office work it's about 24 dm<sup>3</sup>/h. Carbon dioxide is also generated in all combustion (candles, gas stove, cigarette). The high carbon dioxide content of air in the room tells from too little ventilation. According to *occupational safety requirements* (fin. työsuojeluväätimus), the harmful content of carbon dioxide is 500 ppm. More detailed guidelines are given in **table 3.2**.

Nitrogen oxides are generated at high temperatures when combusted. Internal sources are for example, gas combustion with open clay for domestic and heating purposes. External sources include transport and heat and electricity production.

Nitrogen oxides has many biochemical effects on humans. It's causing changes in the surface of the respiratory tract already at low concentrations, increasing the respiratory resistance. With blood haemoglobin, nitric oxide reacts in the same way as carbon monoxide. The effect of nitrogen oxide appears as an increase and prolongation of respiratory tract infections.

Carbon monoxide is generated on incomplete combustion. Inexperienced fireplace user may lead to an increased carbon monoxide concentration in indoor air. Carbon monoxide poisoning kills every year many individuals in Finland. Carbon monoxide binds oxygen more heavily to blood haemoglobin and thus causes oxygen deficiency in the body. Mild carbon monoxide poisoning causes headache, nausea, vomiting and night vision deterioration.

Radon is a noble gas generated by breakdown of radioactive radium. Radium is everywhere in soil rock, especially in Finnish granite and moraine. Gaseous form of radon enters the room air through the pore and cracks of the rock soil. Radon mixes evenly with room air. Radioactive radon is formed by the breakdown of solid short-lived products and alpha radiation. If decomposition occurs in the lungs, alpha radiation can damage the lungs. Alpha radiation is 20 times more

damaging than gamma radiation. The majority of Finnish radiation doses, 60 % to 80 % are caused by radon.

The high radon concentration of breathing air increases the risk of lung cancer. Radon has been estimated to cause 300 to 400 lung cancer cases per year in Finland. Effects will arise over a lengthy period. In the Social and Health Ministry's decision, the limit for radon content has been set at 200 Bq/m<sup>3</sup> and the yearly average at 400 Bq/m<sup>3</sup>. **Table 3.2** presents the limit values more widely.

Dangers of radon can be reduced by avoiding building on radiant soil, taking care of the base floor tightness and sufficient ventilation. When constructing a building into a radiant soil, care must be taken to ventilate the base floor. Underneath the base floor is installed radon collection pipework, which is in under pressure as compared to the soil. The radon gas is led through the collection pipework on to the rooftop.

Formaldehyde is a widely used chemical in the industry used in the manufacture of adhesives and surface treatments. It's used in chipboards, laminates, various coatings, varnishes, textiles etc. The formaldehyde emission of many materials depends on temperature and humidity. Indoor air concentrations are highest at the beginning of the heating season in the autumn when the room air is humid.

Formaldehyde causes symptoms even in small concentrations. Effects begin with eye and respiratory irritation which are similar to symptoms caused by dry or dusty air. Formaldehyde is also classified as a cancer risk.

The stinging smell of formaldehyde begins to feel as the concentration exceeds 50 µg/m<sup>3</sup>. Higher concentrations also cause headaches, nausea, fatigue and skin symptoms. Target value for formaldehyde is presented in **table 3.3**.

In the **tables 3.2** and **3.3** the target value of carbon dioxide level is concerning carbon dioxide from human sources.

**Table 3.2.** Target values of air quality in indoor climate classification 2008

	<b>S1</b>	<b>S2</b>	<b>S3</b>
Carbon dioxide level (ppm)	<750	<900	<1200
Radon level (Bq/m <sup>3</sup> )	<100	<100	<200
Stability of conditions (% of usage time)			
• Office and educational premises	95 %	90 %	
• Apartments	90 %	80 %	

**Table 3.3.** Target values of gaseous pollutants in the old construction regulation collection part D2

<b>Impurity</b>	<b>Unit</b>	<b>Maximum concentration</b>
Carbon dioxide	ppm	1200
Ammonia and amine	µg/m <sup>3</sup>	20
Formaldehyde	µg/m <sup>3</sup>	50
Carbon monoxide	mg/m <sup>3</sup>	8
Radon	Bq/m <sup>3</sup>	200 (yearly average)
Styrene	µg/m <sup>3</sup>	1

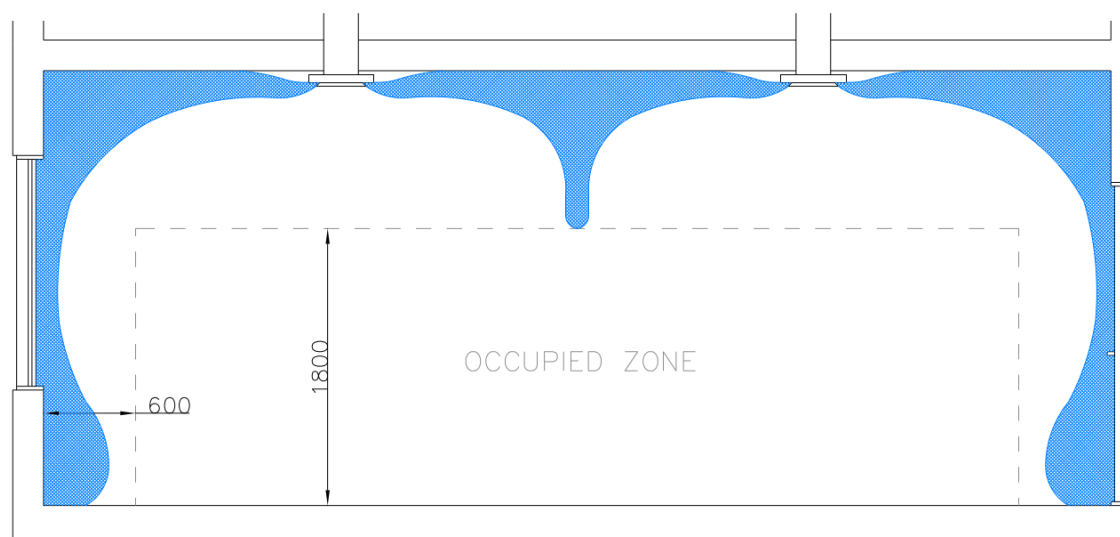
### Supply air filtration

Filtration level of supply air determines by appointed requirements to indoor air quality and by outdoor air quality. Filtration of supply air is planned usually so, that the level of separation of air filters are at least 80 % with 1,0 µm particles in lifetime of filters. The equivalent air filter class to this is F7. Supply air filtration of buildings outside of population centers and industrial areas and far from busy roads is usually planned so that the air is filtered at least with a coarse filter. The equivalent air filter class to this is G4.

### 3.2 Thermal comfort

Thermal comfort is a temperature what person feels in the space. The thermal comfort is dependent on environmental factors, such as air temperature, air velocity, relative humidity, stratification of air and the personal factors such as clothing, metabolic heat, acclimatization, state of health, expectations, and even access to food and drink. However, these variables are very complex to use, so these factors are dropped off to simplify calculations and make inspecting easier. To define thermal comfort and its target values, usually is used operative temperature.

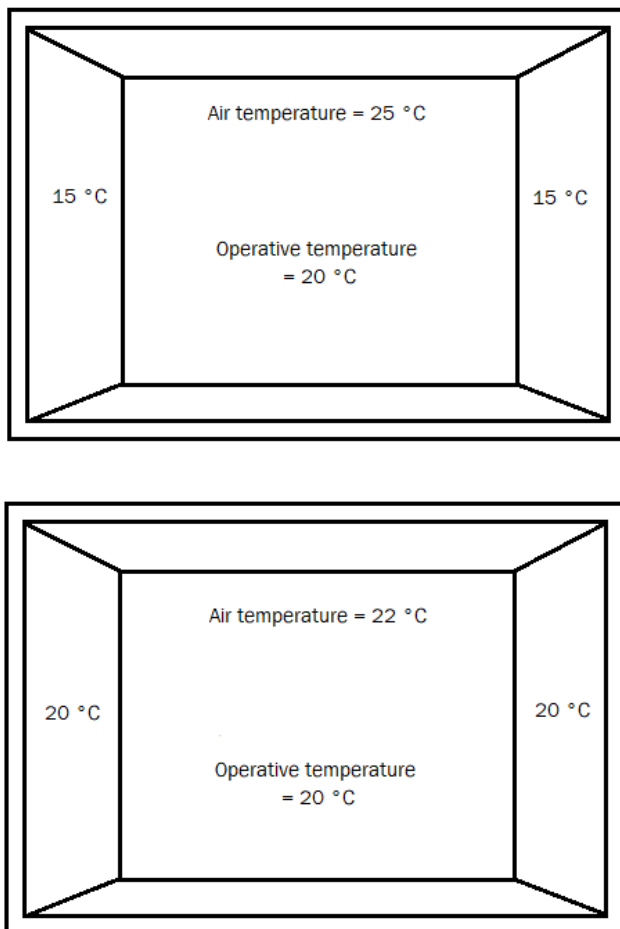
The examination of thermal comforts and air movements takes place in the occupied zone. The occupied zone is defined area, in where people are supposed to spend most of their time in the room. All the target and guideline values are only considered within the occupied zone. Outside the occupied zone the temperatures can be cooler next to surfaces and the air velocity can be higher than target values along or near the walls or above the zone. The occupied zone is bounded to 1,8 m from the floor surface and 0,6 m from each wall surface.



**Figure 3.6.** Occupied zone and air streams

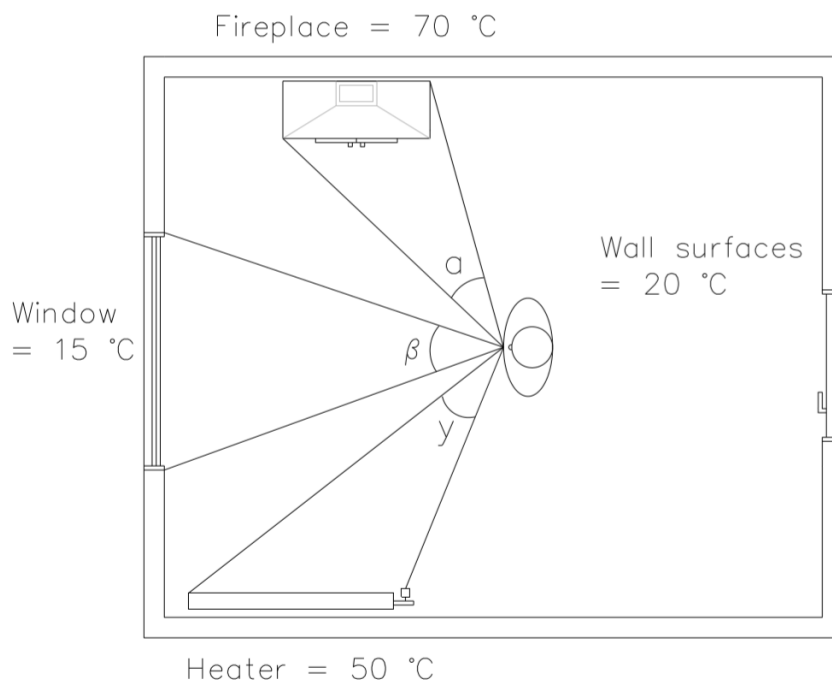
### Operative temperature

Heat is leaving from the body mainly with convection and radiation. Therefore, air temperature is affecting as much as temperatures of surfaces to the felt temperature. The joint effect of surfaces is indicated with radiation temperature, which is approximately the window and wall area weighted average temperature. The size of convection depends on air velocity and temperature. The joint effect of radiation and convection is expressed with the operative temperature. The operative temperature is approximately average of air temperature and radiation temperature. **Figure 3.7** presents how same operative temperature can be achieved with different combination of air temperatures and surface temperatures.



**Figure 3.7.** Same operative temperature achieved with different air and surface temperatures

Temperatures of surface can be influenced with a good insulation. The better the insulation is, the closer surface temperature is to the air temperature. **Figure 3.8** presents how radiation temperatures of surfaces are affecting the determination of the operative temperature. Areas of the heat sources are affecting for the radiation temperature. In the picture, presented radiation temperatures are weighted averages by surface areas.



**Figure 3.8.** Determination of operative temperature

**Formula 3.1** presents an example calculation method for the average radiation temperature of surfaces. In the formula,  $T_r$  is the average radiation temperature of surfaces,  $\alpha$ ,  $\beta$  and  $\gamma$  are the size of angles of the heat source from the measuring point,  $T_\alpha$ ,  $T_\beta$  and  $T_\gamma$  are temperature of the heat sources and  $T_w$  is temperature of the walls.

$$T_r = \frac{\alpha \cdot T_\alpha + \beta \cdot T_\beta + \gamma \cdot T_\gamma + (360^\circ - (\alpha + \beta + \gamma)) \cdot T_w}{360^\circ} \quad (3.1)$$

By placing the values obtained in **figure 3.8** into **formula 3.1**, it will become in the following form:

$$T_r = \frac{31^\circ \cdot 70^\circ \text{C} + 39^\circ \cdot 15^\circ \text{C} + 30^\circ \cdot 50^\circ \text{C} + (360^\circ - (31^\circ + 39^\circ + 30^\circ)) \cdot 20^\circ \text{C}}{360^\circ}$$

$$T_r = 21,5^\circ \text{C}$$

Room air temperature is measured from same measuring point which is presented in the **figure 3.8**. The room air temperature is measured average from three different heights from the floor surface: 0,1 m, 1,1 m and 1,7 m. Operative temperature of the room can be determined by the average of the radiation temperature of surfaces and average of the room air temperature. **Formula 3.2** presents calculation method for the operative temperature ( $T_o$ ) by average radiation temperatures of surfaces ( $T_r$ ) and the average room air temperature ( $T$ ), which is said to be in this case 20 °C.

$$T_o = \frac{T_r + T}{2} \quad (3.2)$$

By placing the values in the **formula 3.2**, it will become in the following form:

$$T_o = \frac{21,5^\circ \text{C} + 20^\circ \text{C}}{2}$$

$$T_o = 20,75^\circ \text{C}$$

Indoor conditions where the temperature difference between air and surfaces is not higher than 10 °C and the air velocity is low (less than 0,2 m/s) the operative temperature is close to the average of the room air temperature and the average of the surrounding surfaces.

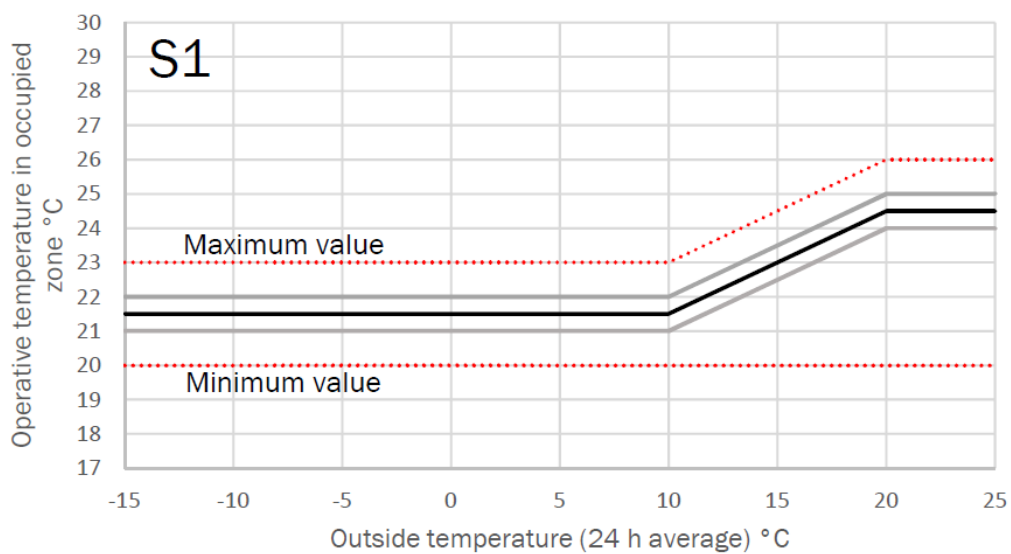
**Figures 3.9, 3.10** and **3.11** on below, presents target values of operative temperature with relation to outside temperature in the different indoor climate



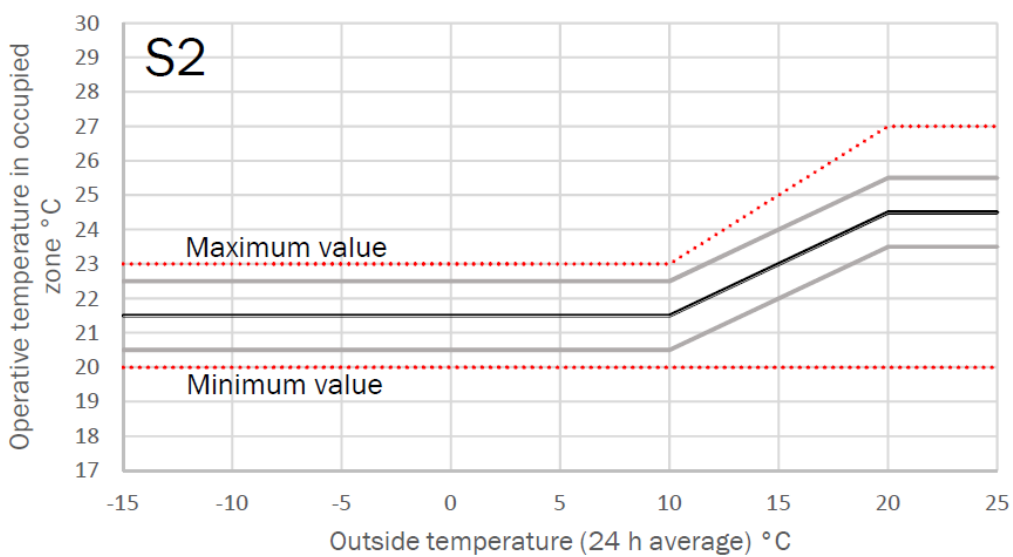
classes. In the figures, black line represents target value of operative temperature and grey lines represent allowed varies for the target value of operative temperature. Operative temperature should stay inside grey lines 90% of time. Red dash line represents maximum and minimum value for the operative temperature. **Table 3.4** presents target values of operative temperature more accurately.

**Table 3.4.** Target values of operative temperature

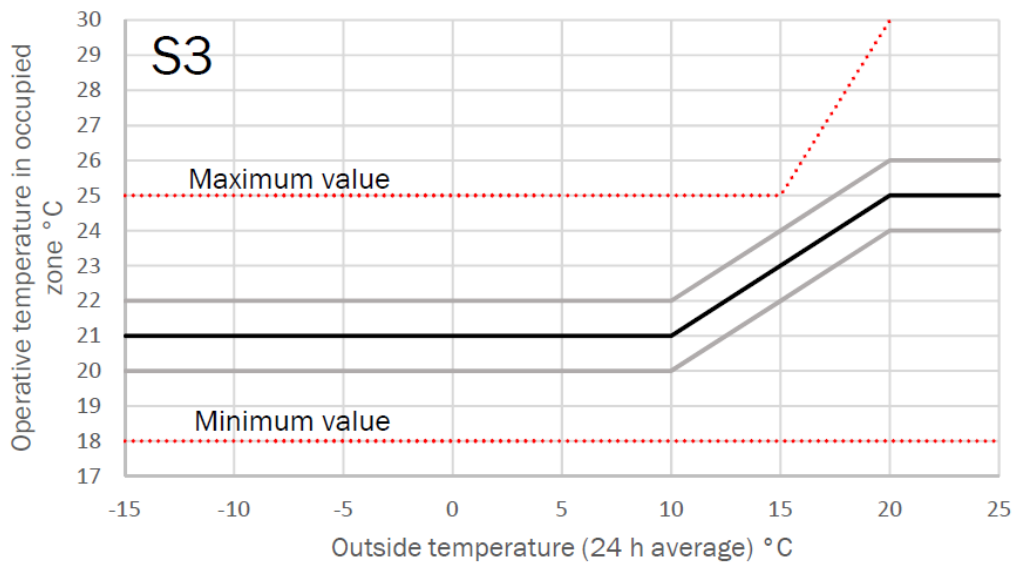
	S1	S2	S3
Operative temperature $t_{op}$ (°C)			
$t_o \leq 10$ °C	21,5*	21,5	21
$10 < t_o \leq 20$ °C	$21,5 + 0,3 \times (t_o - 10)^*$	$21,5 + 0,3 \times (t_o - 10)$	$21 + 0,4 \times (t_o - 10)$
$t_o > 20$ °C	24,5*	24,5	25
Allowed anomaly of target value (°C)	$\pm 0,5$	$\pm 1,0$	$\pm 1,0$
Maximum value of operative temperature (°C)	$t_{op} + 1,5$	$t_o \leq 10$ °C: $t_{op} + 1,5$ $10 < t_o \leq 20$ °C: $23 + 0,4 \times (t_o - 10)$ $t_o > 20$ °C: 27	$t_o \leq 15$ °C: 25 $t_o > 15$ °C: $t_{omax} + 5$
Minimum value of operative temperature (°C)	20	20	18
Stability of conditions (% of usage time)			
• Office and educational premises	95 %	90 %	-
• Apartments	90 %	80 %	-
*In the class S1, operative temperature must be adjustable zone/space specifically between $t_{op} \pm 1,5$ .			



**Figure 3.9.** Target values of operative temperature for the indoor climate class S1



**Figure 3.10.** Target values of operative temperature for the indoor climate class S2



**Figure 3.11.** Target values of operative temperature for the indoor climate class S3

### Air movement and draught

The feeling of draught is caused by a higher heat transfer on the skin than normally. Heat transfer is affected not only by movement of air, but also by heat radiation. However, principal factor is air movement. As velocity increases, the heat transfer becomes more efficient and the feel of the draught becomes more sensitively. Also, the proximity of the cold surface (e.g. window) improves heat transfer. Likewise, is affecting the fluctuation of the air movement. The higher fluctuation, the easier it's to feel the draught.

The feeling of draught is individual, but most of the people are feeling it the easiest in the neck. Also, the user feels dissatisfaction, if the air jet meets face, ankles or other body part.

Too intense draught causing by air stream can be result from many reasons. High thermal loads in the space and the resulting high need of cooling by air conditioning is causing easily draught problems. The thermal loads tend to increase air flow rates and the non-isothermal supply air jet is dropping easier

from the roof surface and the feeling of draught is caused easier by the chilly air flow. Often, it's caused by a cold, high window or wall surface without a radiator or other heating device. The mutual placement of ventilation equipment and other building components may also be the reason for turning the air stream too soon into the occupied zone. The location of furniture in relation to ventilation equipment can also have a significant effect for the air stream.

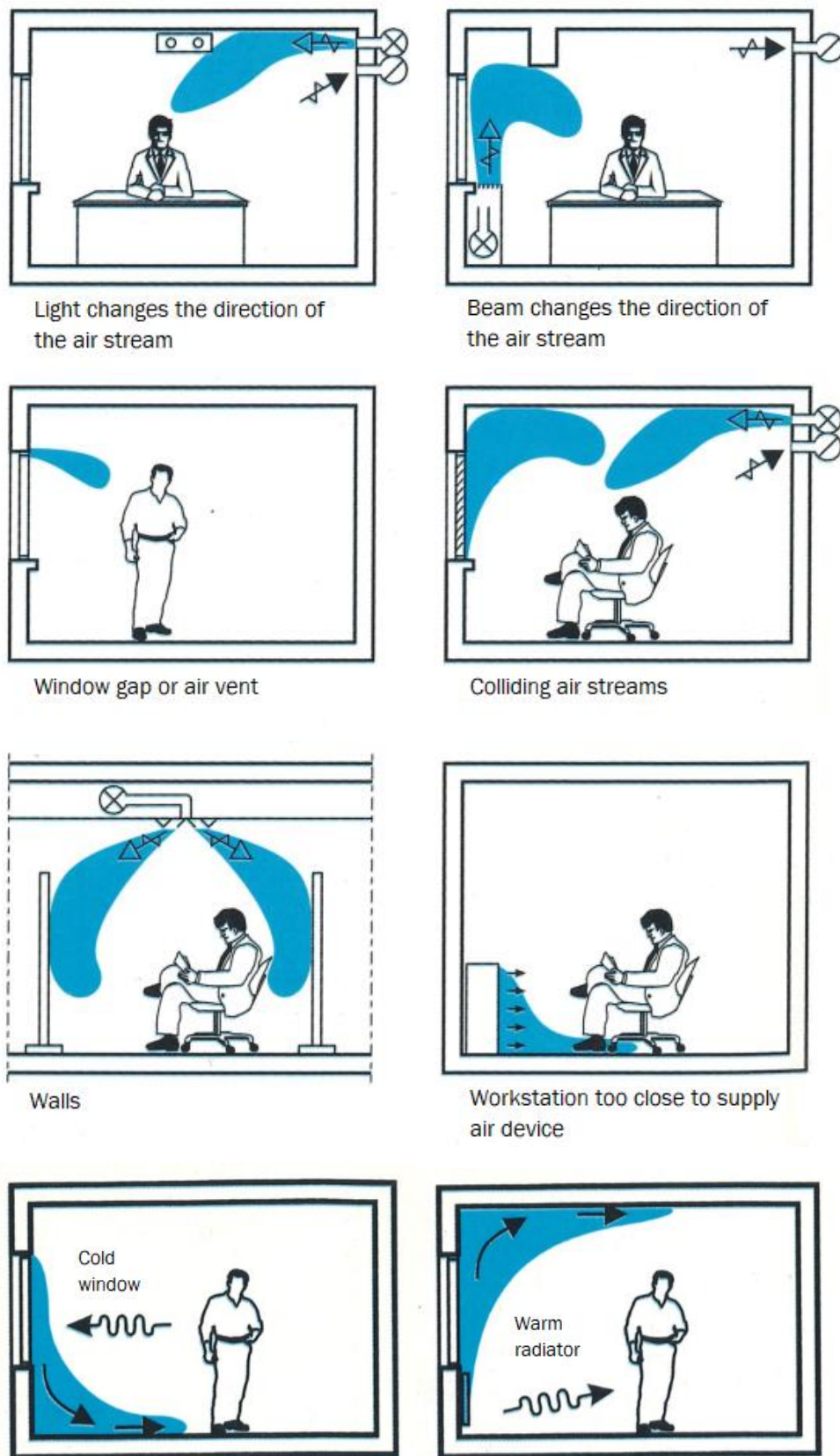


Figure 3.12. Examples of situations which can cause draught (Seppänen, 2004, re-write)

In the **table 3.5**, temperature  $t_{air}$  stands for moving air temperature on inspection point. Air velocity stands for 3-minute average in working station.

**Table 3.5.** Target values of air velocity

	Air velocity (m/s)		
	S1	S2	S3
$t_{air} = 21 \text{ } ^\circ\text{C}$	<0,14	<0,17	0,2 (winter)
$t_{air} = 23 \text{ } ^\circ\text{C}$	<0,16	<0,20	-
$t_{air} = 25 \text{ } ^\circ\text{C}$	<0,20	<0,25	0,3 (summer)

### Humidity in ventilation

Dry air is a mixture of gases, nitrogen, oxygen, argon and carbon dioxide. Usually there is always water vapor in the air, when are talked about humid air. Water vapor plays a significant role in the air, as the vapor has high energy content. If the air is dehumidified, i.e. water vapor is removed, it requires energy as much as water vaporization. And correspondingly if air is humidified, it needs a similar amount of energy.

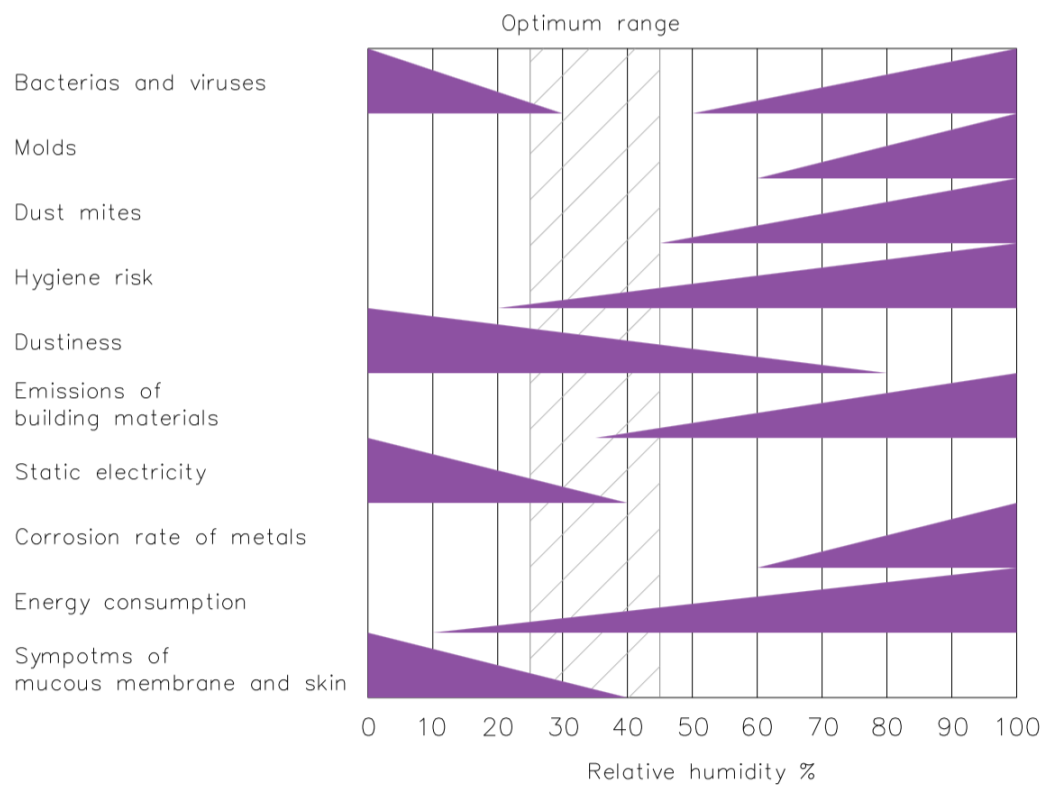
The humidity of the indoor air affects humans, even though the humans doesn't have humidity-sensing sense. Particularly very high and low relative humidity values are sensitized as indefinable sensations on the skin, mucous membranes and respiratory organs.

In Finland, the relative humidity of outdoor air is almost always high. In summer the indoor air is also humid, but in winter the relative humidity of heated rooms is very low, 10 % to 20 %. The low relative humidity causes dryness of the mucous membranes, which again causes irritation symptoms. Especially people with a tendency to respiratory allergy are reacting strongly to this. The winter dryness in indoor air is the most commonly experienced indoor climate harm by an office worker.

The relative humidity of the air also has indirect effects. Low relative humidity increases the dustiness of the air, weakens the strength of paper and textile fibers and increases static electricity. High relative humidity, however reduces dustiness, as airborne particles form larger particles that settle from the air on to the surfaces. The high humidity also increases the pollutant emissions of certain materials such as chipboard.

The relative humidity also has an effect on the growth and spread of different microbes. Room dust mites need more than 45 % relative humidity to feel comfortable and to multiply. Range of multiply of bacteria and mould fungus, depends on the species and usually it's from 60 % to 70 %. However, the mould fungus may also spread spores into a much drier air. The risk of the mould growth is very high if the building structures become wet due to water leakage, condensation etc. The mould grow even there is no visible moisture detected. Long-term high humidity in air or structures always cause health risks and damage to the building. Especially, long-term high humidity in wet rooms, sauna and bathroom should be avoided and proper care of drainage and ventilation must be ensured.

Although humid air has been found to be more comfortable and healthier than completely dry, it's still necessary to consider carefully increasing the relative humidity of indoor air by humidification. Air humidification involves some risks. The greatest risk is caused by microbes and mould spores if they get into the room air. These can come either directly from the humidification water, especially when using misting humidification, or by condensation caused by humidification and resulting mould growth on duct walls and structures. In this sense, a steam humidifier with pure water can be considered as the safest humidifier. For other types of humidifiers, the risk may be reducing to some extent by good cleaning of the devices. **Figure 3.13** shows effects of indoor air relative humidity.



**Figure 3.13.** Effects of indoor air relative humidity. The thickness of line represents magnitude of the factor

In ordinary buildings in Finland, the supply air is only humidified today as for special reasons. When fitted carpet were common in the 1960s to 1980s, humidification was used for reducing their static electricity. The carpets were then removed due to indoor air problems and at the same time humidification. In the rooms of allergic person or other person suffering from dry air, the air is often humidified with steam humidifiers during winter, which are very hygienic properly maintained.

In residential buildings, guideline values of air flow rate for the ventilation of the bathroom are determined according to the humidity removal requirement so that the air humidity cannot be condensed too long times on walls, floor and windows. If there is not enough ventilation, like in many older buildings, it may be necessary to use separated air dehumidification.



There are many processes in the industry that require proper temperature and humidity for the right functioning. The most demanding are cleanrooms for electronics, where the temperature and humidity requirements are very high. There are also requirements in the laboratories, pharmaceutical industry, printing houses, paper mills etc. In the pharmaceutical industry, the preparation of pills is requiring very dry conditions. In the paper mills and printing houses, the paper shrinks and expands as the relative humidity changes, due to this the imprint can be inaccurate. Also, too dry paper breaks easily in printing machines. In the sawmilling and carpentry industry and in the clothing industry, humidification is required at least on winter. The relative humidity is important while storing food, roots vegetables and vegetables. In museums due to artworks and music rooms due to instruments is important to keep a certain relative humidity.

### **3.3 Sound and noise**

Sound and noise are very individual things and people experience them in different ways. Noise can be defined as unwanted sound that becomes noise when the sound interferes with human activity or is unnecessarily strong. Experiencing anxiety can also depend on the time and situation. For example, if a person tries to concentrate on a job, a conversation of colleagues or other environmental sound will hinder their work, even if they are not hindered at other times. Impulse noise (tapping, dropping water from the tap, traversing the train) is more disturbing than constant steady noise, such as the constant fan noise.

When the noise is strong enough, it results in health effects such as immediate or developing hearing loss and sleep disorders.

Residential buildings have, according to a large study (Eskola & al. 2005), used ventilation units with too small air flow rate and this has caused worse indoor air quality. The biggest reason for reducing ventilation was noise, although the sound level was below the regulations. In residential buildings, it should become familiar with sound technology and set goals high enough.

Ventilation systems have many sources of noise. The biggest sources are fans, compressors, duct components and terminal devices.

Fans are the most significant noise source. The noise of the fans proceeds through the components and channels of the air handling unit to the rooms and outdoor openings and through the casing of the fan into the air handling unit room. For fans must be always installed silencers in the air handling unit or supply and extract air ducts.

Flow noise is generated in the ducts in the places where a pressure loss occurs. The pressure loss is the most caused by flow dampers, fire dampers and flow measuring gauges, if necessary, a silencer should be used after these parts if the attenuation of the terminal device and its plenum box is insufficient.

The terminal devices absorb the noise from the fan and the ductwork, but at the same time produce the noise itself, so these noises should be added to the terminal at the room noise level. The interaction between the all terminal devices in the room must be taken into account.

Noise regulations and instructions are presented in the Ministry of Environment's decree *sound environment of the building* and on Indoor climate classification 2008.

The Ministry of Environment's decree on the sound environment deals with soundproofing of buildings, noise and vibration and sound conditions as well as the noise control and sound conditions of the buildings, courtyard and living areas of the building and balconies of the building.

**Table 3.6** presents guideline values of sound given in the Ministry of Environment's decree *sound environment of the building*.

**Table 3.6.** Guideline values of sound

Space	Continuous broadband sound		Impulse or narrow-band sound	
	Average sound level, $L_{Aeq, T}$ (dB)	Maximum sound level, $L_{AFmax, T}$ (dB)	Average sound level, $L_{Aeq, T}$ (dB)	Maximum sound level, $L_{AFmax, T}$ (dB)
Residential, housing or patient room	28	33	25	30
Kitchen or hobby room of residential building	33	38	30	35
Stair case or exit corridor	38	43	35	40
Outdoor space	45	50	40	45

The sound conditions of the building, presented in Indoor climate classification 2008, are planned in accordance with standard SFS 5907 *acoustic classification of buildings*. In standard, the class A corresponds to the highest target level and the class C is the so-called minimum level. The acoustic category of space is selected individually. In the indoor climate class S1, the target level is class B, but the target values can also be selected from classes A or C in each case. **Table 3.7** presents examples of acoustical planning target values corresponding to classes S1, S2 and S3.

**Table 3.7.** Acoustical planning target values

Space and quantity		Unit	S1	S2	S3
<b>Residential room</b>					
Air insulation value between two apartments	$R'_w$	dB	≥58	≥55	≥55
Sound level of HVAC devices in residential rooms	$L_{A,eq}$	dB	≤24	≤28	≤28
Sound level of HVAC devices in kitchen	$L_{A,eq}$	dB	≤33	≤33	≤33
Sound level of external sources at day time (at 7-22)	$L_{A,eq, 07-22}$	dB	≤30	≤35	≤35
Sound level of external sources at night time (at 22-7)	$L_{A,eq, 22-07}$	dB	≤25	≤30	≤30
<b>Office room for 1-2 person</b>					
Sound level of HVAC devices	$L_{A,eq}$	dB	≤35	≤35	≤40
<b>Negotiation room</b>					
Sound level of HVAC devices	$L_{A,eq}$	dB	≤35	≤35	≤35
<b>Educational space</b>					
Sound level of HVAC devices	$L_{A,eq}$	dB	≤33	≤33	≤33

In industry, very often noise of the production machinery is very strong, so the requirements for ventilation systems are not demanding in that sense. However, the noise of ventilation system should be 10 dB lower than the production machinery so that it doesn't increase the noise level of the production space.

Heavy industry and industrial processes have high air flow rates and high pressure increase with air fans, making the noise produced by them very high. Because of this, more attention must be paid to the environmental noise going to outside the building.

## 4 VENTILATION

Ventilation systems and air conditioning systems generally differ only slightly from each other and therefore even among professionals the terms are used varyingly, but principled difference is in handling of supply air and dimensioning of air flow rates. Often terms are used in disorder, if it's not possible to know function and dimensioning of system of existing building.

Ventilation systems are controlling target qualities of indoor air also known as air purity, in which case the air flow rate is dimensioned on this basis.

Air conditioning systems are controlling also target temperature conditions of indoor air, when chilled supply air flow rate of served spaces is dimensioned by needed cooling power or in addition to previous the air is cooled with separated chillers. In the latter situation, room air is always circulated. Outdoor air can also be dehumidified in the cooling so that relative humidity doesn't get too high indoors. Dehumidification and amount of it depends of the outdoor air conditions. Sometimes air conditioning can involve also other air handlings, like humidification.

Ventilation must be running always in residential buildings, even there is not people staying. Ventilation must remove even small impurities coming through the structures and possible humidity from the indoor air.

Natural ventilation was prevailing ventilation system until the 1970s. Usually kitchen, bath room, toilet, changing room and sauna were equipped with extract air vent. Air was lead through the vent to extract air ducts or flues and via the duct or flue to rooftop. Air moving was based on gravity, which forms from indoor air and outdoor air density differences and from height difference of air routes. Density of chilly air is bigger than warm air, so the colder is the frost in winter,

the bigger is pressure difference between indoor air and outdoor air, but correspondingly in summer the pressure difference can be negative. Wind has big effect to function of the system.

Outdoor air (replace air) comes with impurities through structures of building from the easiest way. Ventilation bases on air leaks and on airing by the windows. This requires activity from the users to get good ventilation and comfort in the building.

In 1970s ventilation started to execute with hybrid ventilation systems. This system was used until turn of the century. Usually in the system, kitchen, bathroom, toilet, walk-in closet and sauna is equipped with extract air vent, through which air is sucked to controlled exhaust fan on the rooftop. Usually the controlling happens from cooker hood. Essential parts of the system are door gaps, through which air transferred from residential rooms to the rooms with extraction. Exchanging air comes through the untight structure of building with all impurities, because of the under pressure what extract air is causing. Some buildings have fresh air vents placed into the living rooms and bedrooms. The air flowing through the vents are causing easily draught.

Natural ventilation systems and hybrid ventilation systems are unlikely fulfilling the energy efficiency regulations and the target values of indoor climate in nowadays, therefore are not used anymore in Finland.

In the Finland's construction regulation collection, the planning and implementation of the ventilation system in the residential buildings have been ordered and instructed on the following ways:

Ventilation must put into practice a healthy, safe, and comfortable indoor air quality in the residential rooms. The ventilation system shall provide sufficient outdoor air flow rate into the building and remove from the indoor air substances harmful to health, excessive moisture, discomfort scents and also impurities caused by humans, construction products and activities.

Ventilation systems must be planned and built so that:

- Rightly used and maintained, it will last operationally planned lifetime.
- Operations of ventilation system must be possible to control and inspect. Measuring devices or measuring possibility must be planned and installed for measuring and inspecting of the most important operating values in ventilation systems. This means that ventilation systems must contain control, adjustment and inspecting devices.
- Ventilation system must be planned and built that it's possible to shut off easily in alert situation. Mechanical systems must contain a clearly marked shut off switch.

Residential rooms must be guaranteed with healthy, safety and comfortable outdoor air flow rate. Dimensioning happens primary with individual room guideline values (see **table 4.1**). The outdoor air flow rate determines primary by persons, but if dimensioning by person doesn't have grounds, it's dimensioned by area. However, the outdoor air flow rate of the entire building must be dimensioned at least to  $(0,35 \text{ dm}^3/\text{s})/\text{m}^2$ .

Air flow rates must have possibility to control it by loads and air quality to match it to using situation. Ventilation of building is planned and built so that ventilation can be intensified with 30 % from the planned air flow rates of using time. If ventilation is controlled individually in the apartment and the apartment isn't under the use, air flow rates can be lowered maximum 60 % from the planned air flow rates of using time.

Ventilations of other buildings than residential buildings, is planned and built so that the outdoor air flow rate must be at least  $0,15 \text{ (dm}^3/\text{s})/\text{m}^2$ .

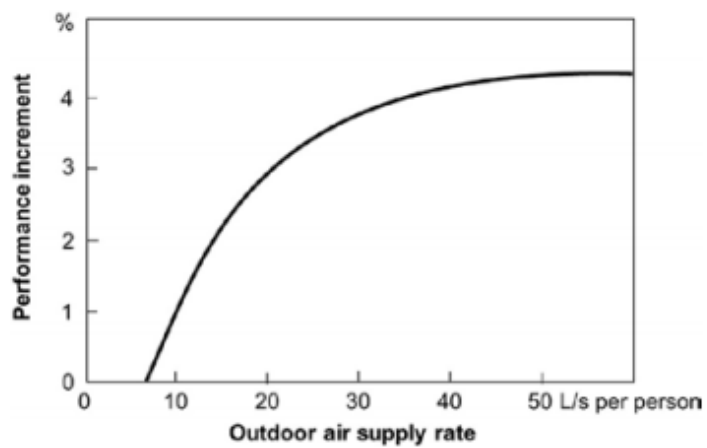
## 4.1 Air flows

Outdoor air flow rate and exhaust air flow rate are usually dimensioned to be equal in the ordinary buildings. For example, classrooms and offices usually have equally dimensioned supply and extract air flow rates. Supply air is blown into corridors and residential rooms and extract air is extracted from toilets and closets, hence the air flow rate balance remains in the whole building. Buildings can have also other unclean spaces, which should be in under pressure relative to other spaces, in which case the direction of air flow is facing to the unclean space. Pressure difference is achieved usually with air flow rates.

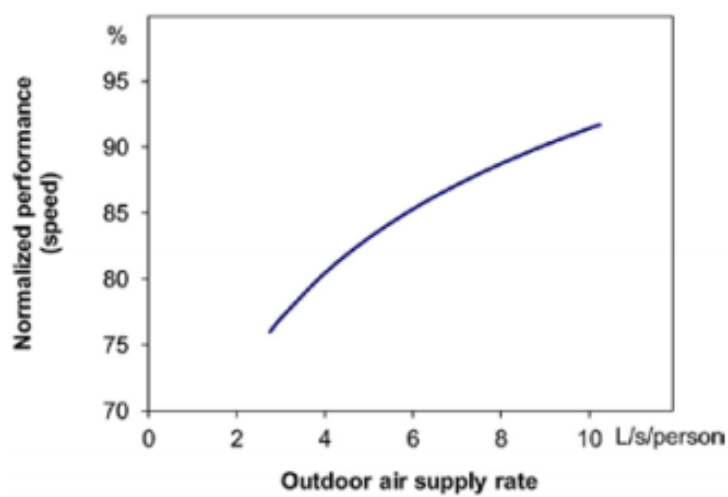
Exceptions to the air flow rate balance are residential buildings and apartments, where are strived to get under pressure situation so that the total extract air flow rate is 5 % to 10 % bigger than the supply air flow rate. This ensures that the indoor air humidity cannot penetrate through the vapor barrier into the structures and thus cause moisture damages. Detached and terraced houses with 2 or more floors, should also be considered by the individual floor air flow rate balance as well as the pressure difference caused by the differences between indoor and outdoor air flow rates, which can make upper floors over pressured relative to the outdoor air. Too high under pressure increases the supply of exchange air through the structures and can cause vapor condensing on the leakage point due to cooling of the structures.

In addition to health effects, indoor air and ventilation have other impacts. Extent of air flow rate correlates positively to the efficiency of work in office-type work. **Figure 4.1** presents increment of performance with relation to outdoor air flow rate. In schools, good ventilation improves learning results. **Figure 4.2** presents learning speed with relation to outdoor air flow rate.





**Figure 4.1.** Efficiency of work with relation to outdoor air flow rate (Ympäristöministeriö, 2017)



**Figure 4.2.** Learning speed with relation to outdoor air flow rate (Ympäristöministeriö, 2017)

## Determination of air flow rates

Air flow rates of ventilation for the spaces are determined basically with:

- Counting on grounds of impurity, heat and humidity loads or
- Using published guidelines

The use of the building, the purpose of the space and the number of people are in fact the most common determinants. In ordinary buildings, the produce of impurities or humidity is not usually calculated, but guideline values are used. They are determined according to the continuous load time, and no time dependence has been considered. According to the thermal load, the need for air flow rates at different seasons is calculated using simulation programs also known as dynamic calculation programs, such as need of cooling in general. Widely used dynamic calculation program in Finland is IDA ICE (IDA Indoor Climate and Energy).

The most common guideline values for the individual spaces are presented in Indoor climate classification 2008 and Finland's construction regulation collection where guideline values are given as outdoor air flow rate per person or per square meter, or extract air flow rate. Some of the biggest developers have their own guidelines for the space individual air flow rates, especially in such cases, when those cannot be found straight from the guidelines. The outdoor air flow rates presented in construction regulation collection are the lowest planning values, which fulfill the construction regulations for indoor air quality.

Generally, the guideline values use the term *outdoor air flow rate*, which refers handled air taken directly from the outdoors. This term is often mixed with the term *supply air flow rate*. The supply air flow rate may also contain recirculated air, when it's not completely outdoor air. However, nowadays the use of recirculated air is uncommon in new buildings.

In industry, determination of air flow rates is usually based on the values obtained by calculating the impurity, heat and humidity loads. In some situations, all loads must be calculated. The most demanding thing is to determine the load on the industrial process. In ordinary industry halls, where no impurities are produced and the heating happens with air heating, air flow rate is determined by the needed heating power.

When air flow rates are dimensioned on the grounds of loads, it's necessary to know or be able to calculate different loads. It's also to be considered, whether a dynamic calculation is required for dimensioning. This section shows the principles of calculations for impurity, heat and humidity loads.

### **Calculation based on impurity load**

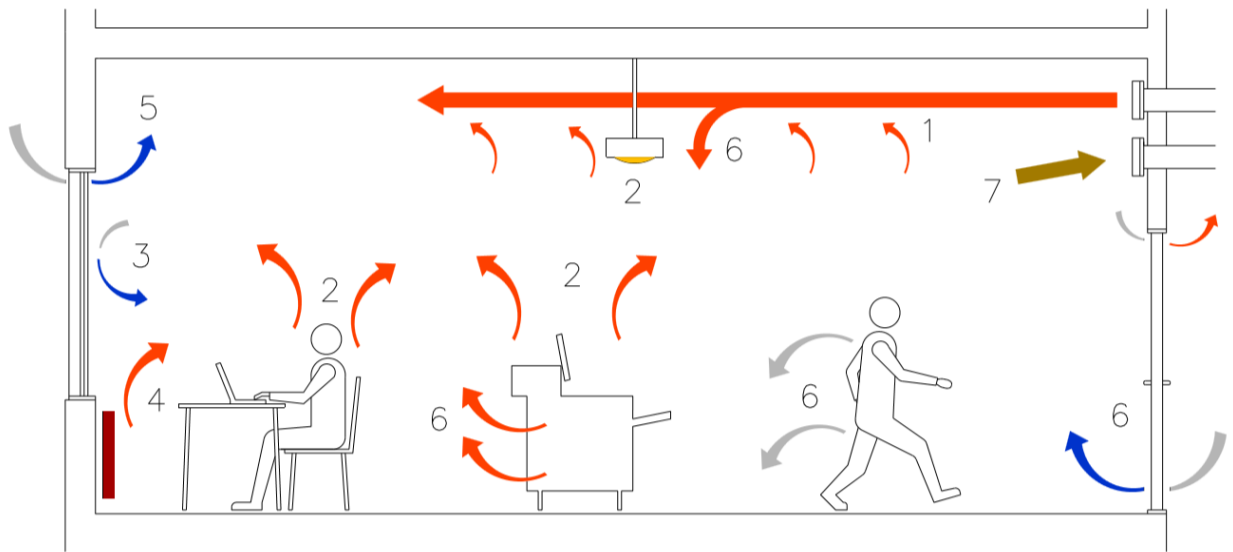
In ordinary space, impurities are generated from people, cooking, appliances etc. Impurities are released from building and decoration materials: walls, ceiling, floor, furniture, textiles, glues, seals etc. These things are strived to control with the emission classification of building materials. Room surfaces also adsorb impurities from indoor air and release them later back. Through air leakages, impurities are flowing from the outside air, structures and adjacent spaces, in proportion air leakages are leading the impurities away from the space. Supply air brings impurities depending on the level of filtration and the cleanliness of the ductwork.

In the following, only considered thing is human contaminants, for which a good indicator is carbon dioxide ( $\text{CO}_2$ ). The humans are producing many different impurities, but calculation of these are quite complicated. Carbon monoxide is easy to measure, so keeping track of its level, can it be used to inspect the indoor air quality, as long as it takes into account that the impurities from structures and decorations are individually inspected.

Industrial processes are producing impurities and heat. Emission of impurities are individually inspected and the most effective local extractions are used to minimize the effects of the straining impurities. If possible, the process and the substances used are modified so that the emissions will be smaller and less harmful. The required ventilation air flow rate is calculated according to the allowed levels also known as the guideline values.

Impurities of the air are moving along with air flows. Therefore, all deviating air flows in the room need to be known, if desired to determine the emissions at various points in the space. **Figure 4.3** presents possible air flows in the space.

- Supply air flow, which has big effect to the room flows, when used mixing air conditioning strategy or zoning air conditioning strategy (1)
- Convection flows caused by internal convections, which has big effect to room flows, when used stratification air conditioning strategy (2)
- Convection flows caused by warm and cool walls (3)
- Convection flows caused by heating radiators (4)
- Infiltration (5) and different disruption flows, like air flows through the doors (6), human's movement (6), movement of appliances and machines (6), effects of flow blockages to supply air flows (6)
- Impurities are flowing into extract air device (7)



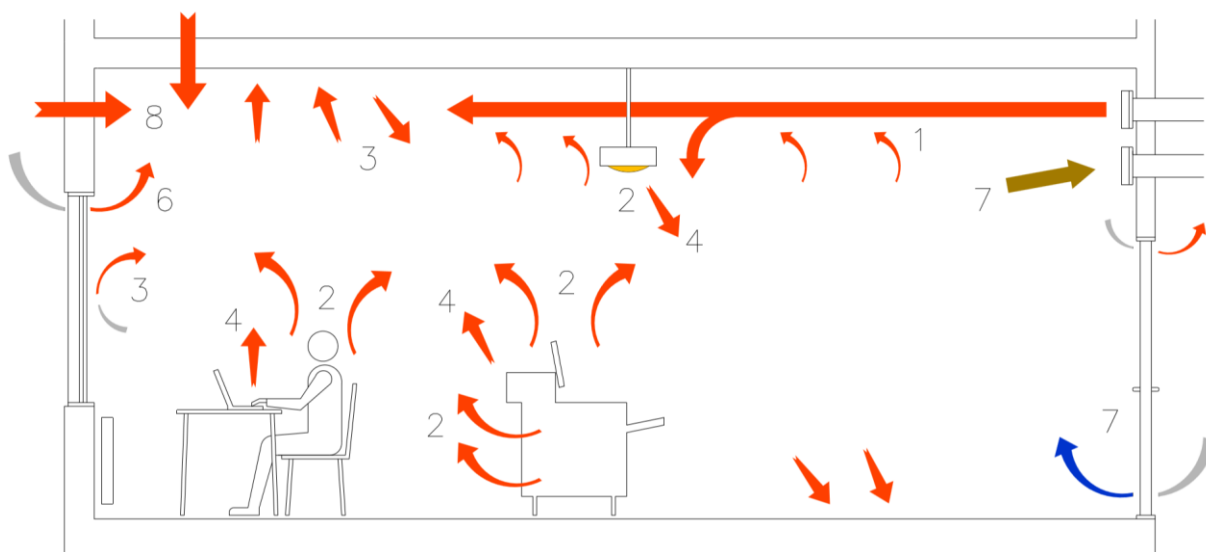
**Figure 4.3.** Factors effecting to room flows. Impurities are moving along with the room flows

Usually it's assumed that room flows and impurities are mixed, when the average emission of the indoor air is inspected, or alternatively emission of the occupied zone and the extract air is inspected individually.

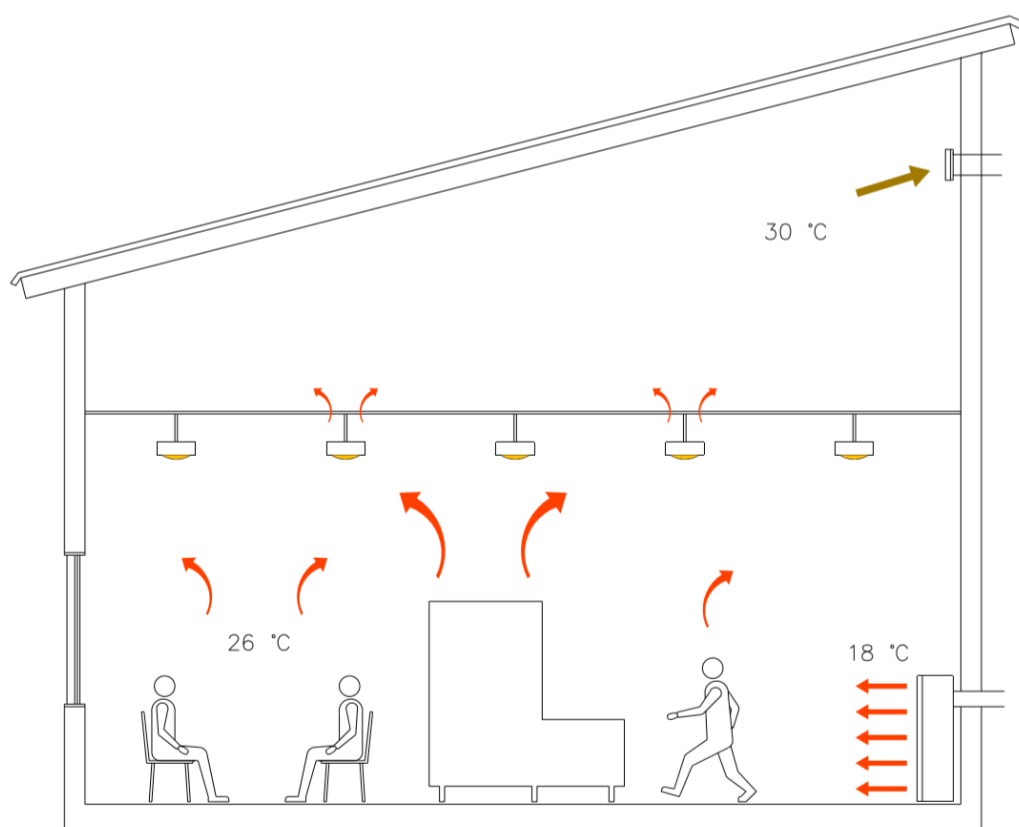
#### Calculation based on thermal load

The figure 4.3 presents room impurity flows, and many of them were conveyed by heat flows. In figure 4.4 heat flows have been described more accurately. In addition to convection, heat radiation from internal sources (4) and between room surfaces (5) also affects room temperature. Heat transfer happens also through the walls (8) and the heat stores in the structures and furnishings. Due to radiation, the stratification of the temperature is usually less than the stratification of the impurities.

When dimensioning the air flow rate of the room, based on heat flows, usually is used time-dependent calculation and purpose-built dynamic simulation programs.



**Figure 4.4.** Heat flows of the room. Heat is transferring also by radiation and conduction



**Figure 4.5.** Stratification of temperature increases the temperature difference between the extract air and supply air, and decreases the need of the air flow rate

### Determination based on the guidelines

When the room air flow rates are determined based on the needed cooling power, the required air flow rate should be calculated room specifically. On the other hand, when dimensioned based on impurities, it's not sensible start to calculate separately the outdoor air flow rate required for each room, but use the published guideline values. They are based on the typical use of the space and the impurity load. For the extract air flow rate, room specific guideline values are used for example in hygienic facilities.

The guidelines of outdoor air flow rate are usually expressed by the number of the people so that the presented outdoor air flow rate ( $\text{dm}^3/\text{s}$ ) is per person ( $\text{dm}^3/\text{s}/\text{pers}$ ). If the number of persons is unknown, the outdoor air flow rate is alternatively indicated per floor area ( $\text{dm}^3/\text{s}/\text{m}^2$ ). These guidelines have considered both, the impurity loads from humans and materials.

The extract air flow rate guideline values are usually provided per floor area ( $\text{dm}^3/\text{s}/\text{m}^2$ ) or per spot or fitments that is used in sanitary or hygienic facilities, for example in toilet facilities per a toilet seat or urinal ( $\text{dm}^3/\text{s}/\text{spot}$ ). In the most cases, hygiene facilities don't have individual supply air flow rate, because transfer air is led from the cleaner rooms. This also creates under pressure in the hygiene facilities and neither increase the need of supply air flow rate.

### Finland's construction regulation collection

Finland's construction regulation collection's part *healthiness* gives regulations and instructions for achieving healthy and comfortable indoor climate in building. It's considered a minimum requirement for air flow rates in a new building in Finland.

Space specific guidelines are published for differently used buildings and spaces:

- residential buildings
- Office premises
- Educational buildings
- Restaurants and hotels
- Stores and theaters
- Sports buildings, swimming pools, barracks
- Hospitals
- Public buildings like service stations, libraries, churches
- Work spaces like factory work, laboratories, garages
- Food preparing and storage spaces
- Hygiene facilities
- Motor vehicle garages

Generally, the total supply and extract air flow rates of the building or part of it are dimensioned to be equal, so that there is no harmful pressure difference over the indoor and outdoor. The amount of supply and extract air flow rates are determined so that the flowing direction of air is from cleaner rooms to the unclean rooms. The supply air flow rate must also correspond to the amount of extract air flow rate, when the extraction happens with a separated extraction system.

When determining the amount of air flow rates, should be considered that increasing the air flow rates are not necessarily improving the air quality. Particularly in winter, the indoor air dries when the ventilation increases. Large ventilation also increases draught and noise nuisance. Outdoor air contains harmful particles that are harmful to health and the concentration of those may increase inside the building as the ventilation increases. Unnecessary enlargement of ventilation increases energy consumption.

Use of buildings and premises may vary depending on the time. To avoid unnecessary ventilation, it must be capable of being controlled in accordance with the



condition of use and need of ventilation. When use of the space varies significantly (utilization rate less than 50%) e.g. conference rooms, halls and many other public spaces.

In every room where people are staying and in an entire residential building, the minimum outdoor air flow rate must be at least  $0,35 \text{ (dm}^3\text{/s)/m}^2$ , which match ventilation factor  $0,5 \text{ 1/h}$  with a room height of  $2,5 \text{ m}$ . The minimum outdoor air flow rate per person in every residential room must be at least  $8 \text{ dm}^3\text{/s}$  and in residential rooms larger than  $11 \text{ m}^2$  it must be at least  $12 \text{ dm}^3\text{/s}$ . The outdoor air flow rate of entire residential building must be at least  $18 \text{ dm}^3\text{/s}$ . If a residential building has a sauna,  $6 \text{ dm}^3\text{/s}$  is added to the total outdoor air flow rate. When the load varies, it's necessary to control air flows according to need. The minimum air flow rates of the residential building according to these requirements are presented in **table 4.1**.

**Table 4.1.** Guideline values of air flow rates in residential building

Room	Outdoor air flow rate (dm <sup>3</sup> /s)	Extract air flow rate (dm <sup>3</sup> /s)	Note
Large or only bedroom or over 11 m <sup>2</sup> bedroom	12		
Other bedrooms	8		
Other residential rooms like living room under 22 m <sup>2</sup>	8		Outdoor air flow rate could be compensated partly with transfer air from bedrooms
Other residential rooms like living room over 22 m <sup>2</sup>	0,35 dm <sup>3</sup> /s, m <sup>2</sup>		Outdoor air flow rate could be compensated partly with transfer air from bedrooms
Kitchen, kitchen closet etc.		8 (25)	Air flow rate must be 25 dm <sup>3</sup> /s in intensifying situation. Having enough outdoor air supply need to be taken care of
Bathroom with or without toilet		10	Outdoor air flow rate could be compensated with transfer air from residential rooms
Separated toilet		7	Outdoor air flow rate could be compensated with transfer air from residential rooms
Walk-in closet		6	Outdoor air flow rate could be compensated with transfer air from residential rooms
Storage		6	Outdoor air flow rate could be compensated with transfer air from residential rooms
Sauna	6	6	
From bathroom separated laundry room		8	Outdoor air flow rate could be compensated with transfer air from residential rooms
Technical room		3	Dimensioned according to the thermal load, at least 3 dm <sup>3</sup> /s

The following **tables 4.2, 4.3 and 4.4** presents minimum air flow rates to maintain good air quality in the certain space. Needed cooling or heating power can lead to significantly higher air flow rates. Also, dehumidification may lead to higher air flow rates. The amount of outdoor air flow rate is given the most suitable way depending on the space either per floor area, persons, room or source of pollutants. Outdoor air flow rate is dimensioned according to the criterion, which gives the highest air flow rate. Other instructions have also presented in the tables. Ventilation is designed and constructed in such a way that outside of the using times, the average outdoor air flow rate is at least  $(0,15 \text{ dm}^3/\text{s})/\text{m}^2$  and that the air changes in every space.

Table 4.2. Guideline values for different spaces and buildings

Space	Outdoor air flow rate dm <sup>3</sup> /s, pers.	Outdoor air flow rate dm <sup>3</sup> /s, m <sup>2</sup>	Extract air flow rate dm <sup>3</sup> /s, m <sup>2</sup>	Note
<b>Office premises</b>				
Open-plan office	6	1,5		
Negotiation room	6	3		
Corridor		0,5		
Break room		2		
<b>Educational buildings</b>				
Classroom	6	3		Art lessons etc. at least 8 dm <sup>3</sup> /s, pers.
Corridor/lobby		3		
Lecture hall	6			
Lunch room	6	3		
Day care	6	3		
Mud room			5	
<b>Restaurants</b>				
Restaurant	6	6		
Lunch restaurant, staff restaurant	6	3		
Pizzeria or fast food restaurant	6	6		
Night club	6	10		
<b>Hotels</b>				
Hotel room	6, at least as big as extract air-flow rates			
Bathroom and toilet in hotel room			15	

**Table 4.3.** Guideline values for different spaces and buildings

Space	Outdoor air flow rate dm <sup>3</sup> /s, pers.	Outdoor air flow rate dm <sup>3</sup> /s, m <sup>2</sup>	Extract air flow rate dm <sup>3</sup> /s, m <sup>2</sup>	Note
<b>Stores</b>				
Small store, low impurity load		2		For example a clothing store
Small store, moderate impurity load				From example a grocery store, a book store
Small store, great impurity load				For example a cosmetic store, pet shop, florist's
Big store (> 400 m <sup>2</sup> ), markets	6	1		
<b>Exercise buildings</b>				
Gym	15-25	6		
Gymnasium	15			
Sports hall	25-30			
Stands	6			Individually controlled air handling unit
Swimming pools				Ventilation dimensioning by the humidity loads
<b>Hospitals</b>				
Patient room	10	2,5	As big as the outdoor air flow rate	
Operating room	25, room	2	As big as the outdoor air flow rate	
Waiting room	6	3		Also applies to the corridor if used as a waiting room

**Table 4.4.** Guideline values for different spaces and buildings

Space	Outdoor air flow rate dm <sup>3</sup> /s, pers.	Outdoor air flow rate dm <sup>3</sup> /s, m <sup>2</sup>	Extract air flow rate dm <sup>3</sup> /s, m <sup>2</sup>	Note
<b>Public buildings</b>				
Museum, exhibition center		2		
Library		2		
Theater, concert hall	8			
Theater stands	6	0,35		Controllable by amount of audience, 6 dm <sup>3</sup> /s, pers. + 0,35 dm <sup>3</sup> /s, m <sup>2</sup>
<b>Defence administration buildings</b>				
Garrisons	7	0,35		Outdoor airflow 7 dm <sup>3</sup> /s, pers. + 0,35 dm <sup>3</sup> /s, m <sup>2</sup>
<b>Work spaces/kitchens</b>				
Workspace where is a lot of impurity loads in addition to humans and construction materials.	6	2		Ventilation 6 dm <sup>3</sup> /s, pers. + 2 dm <sup>3</sup> /s, m <sup>2</sup> . Local extractions for clearly restricted impurity sources
Manufacturing kitchen		15	15	
Heating kitchen		10	10	
Catering kitchen		5	5	
<b>Hygiene facilities for the previous one:</b>				
Toilet in workplace, public, school etc.			20/spot	
Bathroom in sport centers etc.		5	16/shower	
Locker room in workplace			4/locker	
Cleaning facility			4	
Staircase		0,5 1/h	0,5 1/h	

## Indoor climate classification 2008

Indoor climate classification 2008 is based on standard EN 15251 and the presumption is that the used materials meet demands in the emission classification of building materials. The air flow rates of the indoor climate classes are based on the target values of CO<sub>2</sub> levels. Indoor climate class S3 is equivalent to minimum values given by Finland's construction regulation collection.

- S3 1200 ppm
- S2 900 ppm
- S1 750 ppm

Air flows are determined for extract the impurities from humans and structures.

- S2 7 (dm<sup>3</sup>/s)/pers. + 0,5 (dm<sup>3</sup>/s)/m<sup>2</sup>
- S2 10 (dm<sup>3</sup>/s)/pers. + 0,5 (dm<sup>3</sup>/s)/m<sup>2</sup>

The outdoor air flow in the class S2 must be in the entire residential building 0,35 (dm<sup>3</sup>/s)/m<sup>2</sup> and in class S1 0,5 (dm<sup>3</sup>/s)/m<sup>2</sup>. The extract air flow rate is dimensioned according to the Finland's construction regulation collection's regulations in all classes. In class S1 and S2 the ventilation, outside the using time is 0,2 (dm<sup>3</sup>/s)/m<sup>2</sup> and has a possibility to intensify air flow rates with 30 % in every hygiene facilities. The bedroom air flow rate is dimensioned at least for two people. The outdoor air flow rate in the living room can be reduced, if the air is supplied to the bedroom and is extracted from the living room.

Table 4.5. Guideline values of Indoor climate classification

Space	S3 (old D2)		S2		S1		Area m <sup>2</sup> /pers.
	Outdoor air flow rate		Outdoor air flow rate		Outdoor air flow rate		
	(dm <sup>3</sup> /s)/pers.	(dm <sup>3</sup> /s)/m <sup>2</sup>	(dm <sup>3</sup> /s)/pers.	(dm <sup>3</sup> /s)/m <sup>2</sup>	(dm <sup>3</sup> /s)/pers.	(dm <sup>3</sup> /s)/m <sup>2</sup>	
Office	6	1,5	13	1,5	16	1,5	12
Negotiation room	8	4	9	4	12	4	3
Corridor	6	0,5		0,5		1	
Break room	6	5	8	5	11	7	5
Classroom	6	3	8	4	11	5,5	2
Corridor/Lobby		4	8	4	11	5,5	2
Lecture hall	6	6	8	7,5	11	10,5	1
Lunch room/cafe- teria	6	5	8	5...6	11	6...8	2
Hotel room	10	1	12	1	15	1,5	10
Business premises		2	10	2	13	2	
Theater, concert hall	8						
Gym		6		6		6	
Gymnasium		4		4		5,5	
Sports hall		2		2		2,5	
Stands	8		8		10		
Patient room	10	1,5	15	1,5	15	2	
Day care	6	2,5	9	2,5	12	4	2,5
Mud room		5		5		5	
Museum, exhibition center		4		4		4	
Library	8	2		2		2	
Preparation kitchen		15		15...40		15...40	
Heating and cate- ring kitchen		10		10		10	



## Extract air classes

In Finland's construction regulation collection, extract airs have been classified into four class according to their pollutant concentrations.

Extract air classes is divided following:

- Class 1: Extract air contains only slightly impurities and impurities are essentially from people and structures
- Class 2: Extract air contains some impurities
- Class 3: Extract air contains impurities, humidity, chemicals or smells that impairs the quality of extract air
- Class 4: Extract air contains significant foul-smells or unhealthy impurities or chemicals

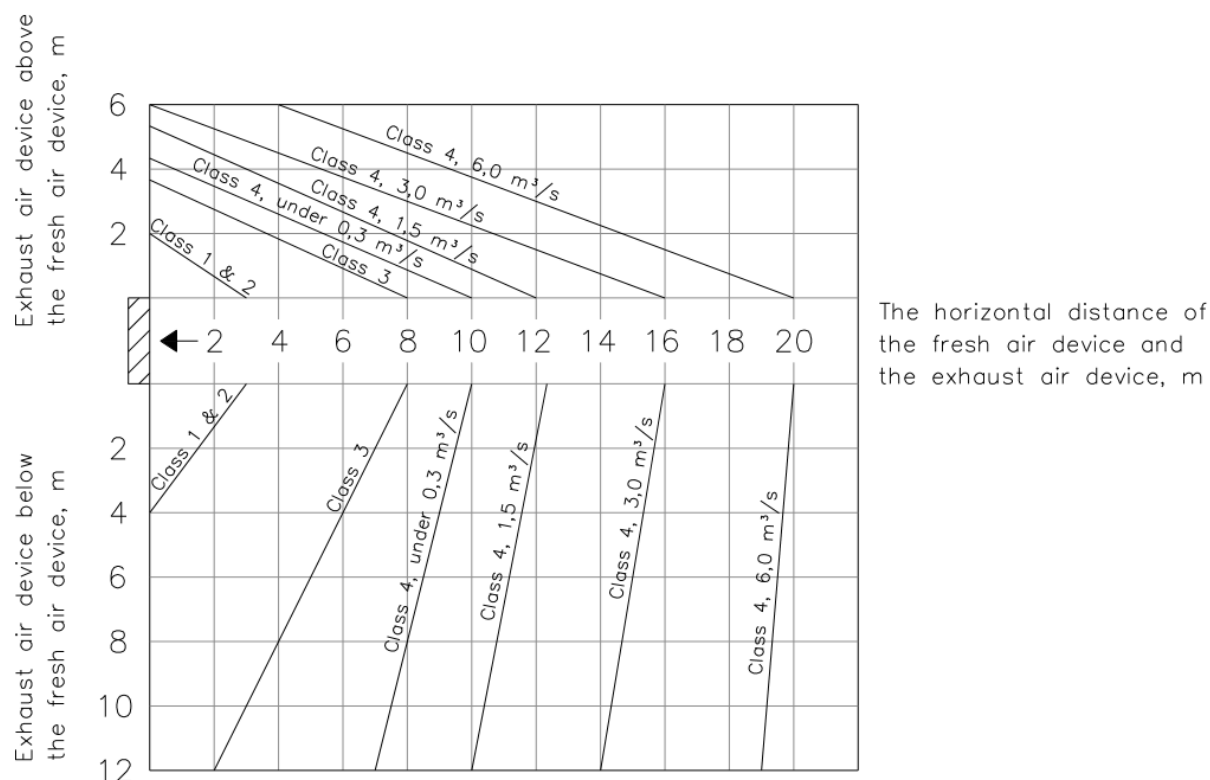
Class 1 extract air is for example extracted from office premises, negotiation rooms or classrooms. Class 2 extract air is for example extracted from bedroom, living room or locker rooms. Class 3 extract air is usually from kitchens or hygiene facilities. The most impurities containing class 4 extract air is extracted for example from garages, dirty laundry rooms and processing rooms.

## Positioning of fresh air and exhaust devices

The positioning of the fresh air device has significant importance for air quality taken into the ventilation system. The air quality varies significantly outside the building, for example due to exhaust air devices, roads, trash cans etc. Also, the compass point of the fresh air device affects to the temperature of outdoor air.

Fresh air devices are placed so that the outdoor air taken into the building is as clean as possible. Fresh air cannot be taken via structure which reduces air quality or close to sources which may reduce the outdoor air quality. Fresh air devices are placed according to **table 4.6** and **figure 4.6**. Values of table are

usually minimum distances. In the **figure 4.6** presented classes are meaning extract air classes.



**Figure 4.6.** Distances between of fresh air device and exhaust air device.

**Table 4.6.** Distances between of fresh air device and exhaust air device.

Distance of fresh air device from:	Distance (m)
Exhaust devices	Picture 2
Sources which can spoil outdoor air quality. For example, waste collection points, parking lots, loading place, vent pipes, chimney openings, blow outs of central vacuum cleaner or cooling towers	8
Vent pipe and chimney opening, if it's over 3 m higher than outdoor air opening	5
Ground level or yard level	2
Roof level	0,9

Minimum distances showed in **table 4.6** can be less in detached houses, except for the distance from permanent fuel boilers, chimneys and roof level. If the building is closer than 50 m from busy road, fresh air devices of building is placed high as possible and usually on opposite side of the building. Fresh air devices must be placed outside of possible balcony glazing.

Exhaust air must be led out so, that it cannot be harmful to health or cannot cause other harms for building, users or environment. Usually exhaust air is led to above the highest point of the rooftop and the blowing direction is upwards. This will prevent exhaust air to find way to fresh air devices, windows and staying areas. Exhaust air devices are placed according to **table 4.7** and the **figure 4.6**. Values of the table are minimum distances.

**Table 4.7.** Placement of exhaust air device

Distance of exhaust air device from:	Distance (m)			
	Extract air class			
	1	2	3	4
Fresh air devices	Figure 4.6	Figure 4.6	Figure 4.6	Figure 4.6
Above opening-window	2	2	4	6
Opening windows on the same level or above	3	3	6	10
Ground level or yard level	2	2	3	5
Roof level	0,9	0,9	0,9	0,9
Neighbour's plot (don't effect on detached houses)	2	2	5	8
Vent pipe and chimney opening	1	1	1	1
Distance between exhaust air devices of natural ventilation and mechanical ventilation	1	1	1	1

## Distribution and extraction of air

Supply air must be led to spaces so that the air is flowing into entire living area without causing draughts and removes effectively all impurities on using time. Contaminated air must not return to staying area in harmful amounts. Ventilation is planned as effective as possible so, that supply air flows to entire living area and impurities move along straight to extract air vents without spreading to space. Supply air can't flow past by the living area straight to extract air vents.

Usually in every building, extract air device is installed into every space, with the exception of residential buildings where extract air devices are installed at least in to kitchens, bathrooms, toilets, laundry rooms and walk-in closets. In this situation air from other rooms can be led with help of transfer air devices or routes.

Local extraction must be used always when steam, dust or gas is forming centrally in the space. For example, this kind of impurities are formed in a kitchen and the used local extraction is cooker hood or extractor fan.

Connecting ducts between different spaces in mechanical ventilation must not cause danger of spreading impurities or flue gasses and any harm for functioning of ventilation system.

Air of different extract air classes is led from the building according to following principles:

- Classes 1 and 2 extract airs can be usually led into shared ductwork
- Class 3 extract air is usually led with individual ducts or with shared ducts if the other space has similar extract air. Toilet, wash and cleaning room extract air can be lead to vertical ducts of extract air class 1 and 2 if the extract air flow rate of these space is not over 10 % of the total air flow of the vertical duct

- Class 4 extract air is led out with individual extract air ducts

If extract air classes 1 and 2 extract air is combined in same duct and the air flow of class 2 extract air is more than 10 % of the combined air flow, combined air flow is classified to extract air class 2.

Spaces must have separated supply and extract ductwork of the rest ventilation system, if there is handled or stored significant amounts of substances harmful to health or the substances are causing strong scents. This kind of spaces can be storages of toxic substances, waste rooms, dirty laundry rooms of dry cleaner.

#### **Recirculated air, transferred air and circulated air**

Recirculated and a transferred air can be only used from spaces which have equal or cleaner indoor air and which must not contain air pollutants that reduces the air quality. Use of recirculated, transferred or circulated air shall not cause harmful spread of impurities, especially smells.

Extract air classes 2, 3 and 4 airs can't be used as recirculated air. Recirculated air can't be used in following spaces:

- Residential buildings
- Professional kitchens
- Accommodations of hotels, boarding schools etc.
- Educational rooms of academies and rest, play and group rooms in kindergarten
- Accommodation departments in hospitals, penitentiary etc.
- Restaurants and coffee houses
- Other, especially clean kept facilities, if return air is not cleaned for the needed level of the facility.

## 4.2 Ductwork

The use of building and their various spaces, the need of heating and cooling power, and the air quality requirements are the starting point of dimensioning the air flow rates and planning the ductwork.

The ductwork of the ventilation systems is set to be the goal of many functional features that need to be considered in planning. The most important functional features are:

- Energy and control technology efficient
- Tightness
- Acoustic controlled
- Stabil flow mechanic
- Working with VAV
- Easily balanced
- Fire safety
- Simple planned
- Easy to use
- Easily and safely maintained (maintenance target is reached easily)
- Aesthetically pleasing

The pressure losses of the ducts and the pressure losses of the machines together determine the energy efficiency of the air conditioning system. When the ducts are dimensioned to be loose, i.e. low air velocity is used, the system will be energy-efficient, easily adjustable and noiseless.

Factors affecting the selection of duct sizes:

- Desirable SFP-value (Specific Fan Power)
- Desirable sound levels

- Easy to balance
- Aesthetics

When looking for a low SFP-value, at the same time the sound levels remain low and balance is maintained. However, sound levels and ability to balance must be observed and determined.

In industry, dimensioning methods are the same as in air conditioning of residential buildings, but the used air velocities are higher due to lower sound level requirements. However, there are huge differences between the various industrial sectors.

The used duct sizing methods are:

- The use of experience-based maximum velocities
  - the most common way
  - determine duct velocities for different duct sizes
- The use of standard frictional pressure loss (Pa/m)
  - typically determined with frictional pressure loss 1 Pa/m
- Static regain method
  - applies only to supply air duct
  - often used in industry

The determination of the duct sizes according to the velocity can be achieved by means of **formula 4.1** or **figure 4.7**.

The air velocity in the duct can be expressed by air volume flow rate or mass flow rate according to **formula 4.1**.

$$v = \frac{q_v}{A} = \frac{q_m}{\rho \cdot A} \quad (4.1)$$

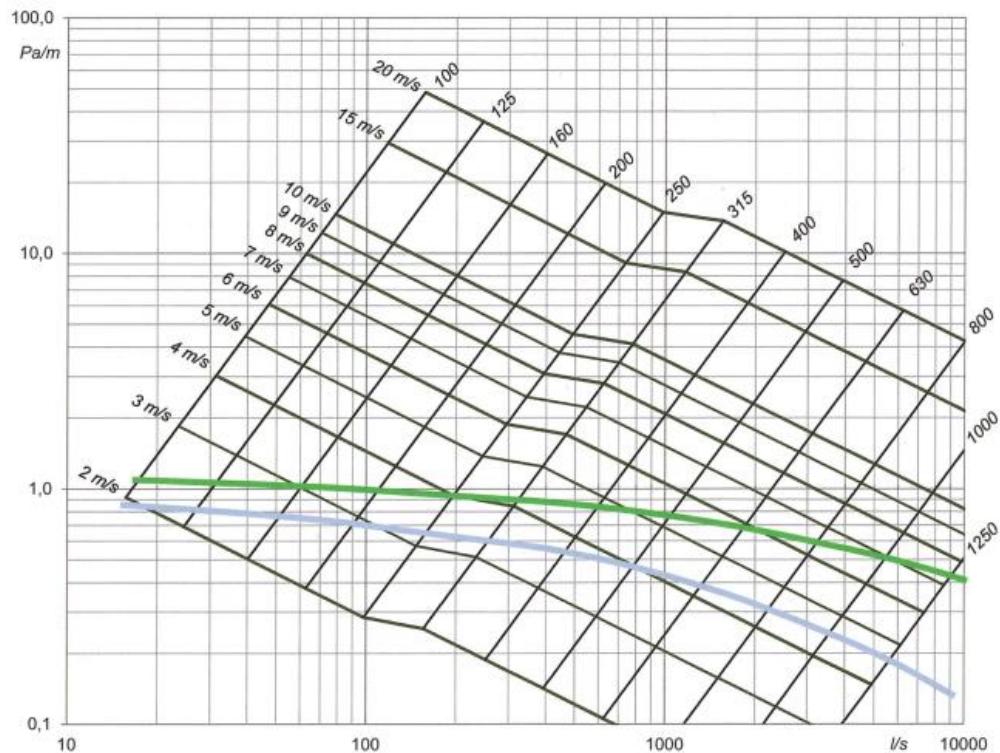
In the formula  $v$  is air velocity (m/s),  $q_v$  is air volume flow rate (m<sup>3</sup>/s),  $q_m$  is air mass flow rate (kg/s),  $\rho$  is air density (kg/m<sup>3</sup>) and  $A$  is cross-sectional area of duct.

If determination accords to maximum air velocity and desired factor is the cross-sectional area of duct, can the formula be remodeled to the following:

$$A = \frac{q_v}{v} = \frac{q_m}{\rho \cdot v} \quad (4.1)$$

Circular ducts can be easily sized with help of **figure 4.7** presented below. For example, the air flow rate required is first defined and the corresponding line rises to the desired sound level. The point shows the frictional pressure loss (Pa/m) and the diameter of the circular duct (mm). The recommended sound level line is indicative and in the ducts closer to the air handling unit can be sized to be tighter.





**Figure 4.7.** Dimensioning scale of circular ducts. Green line presents recommended point where the voice level is 35 dB(A) and blue line presents point where the voice level is 25 dB(A) (Sandberg, 2014)

## Ducts

In standards SFS-EN 12237 (circular ducts) and SFS-EN 1507 (rectangular ducts) is determined the strength requirements for ducts. According to the construction regulation collection the ducts must withstand 1000 Pa under or over pressure. The wall thicknesses of the sheet metal ducts are determined by use of the duct, material and functional requirements, such as fire safety and strength.

The standard wall thickness of the standard sheet metal duct is 0,5 mm ( $\leq \varnothing 315$  mm), 0,7 mm ( $\leq \varnothing 800$  mm) and 0,9 mm ( $\leq \varnothing 1250$  mm). For the purposes of fire safety and cleaning, the material strength of the duct shall be determined

on a case-specific, but the thickness of the wall shall be at least 1,2 mm. Smoke removal ducts also have a wall thickness of 1,2 mm.

The material of sheet metal ducts is usually galvanized steel, but can also be stainless and acid-proof steel, since the ducts will mainly be made of non-combustible building materials. Plastic ducts have long been used in laboratories and industry, but nowadays also in residential buildings.

The air ducts under the ventilated bottom of the elevator shaft are made of steel pipes with welded joints. In industrial processes is typically used welded ducts, whose material and wall thickness are determined according to the needs of process.

Flexible ducts do not usually meet the requirements of fire resistance and strength, nor do they meet the cleansing requirements. Therefore, flexible ducts are not usually used in Finland.

Circular duct joints are made in conventional applications with rubber sealing joints. For special sealing applications, joints should be secured with shrink tape.

The rectangular ducts don't have as good tightness, strength and cleansing as circular ducts. The joints are usually made with the slip and drive joint, but also with flange joints. The rectangular ducts are most often used when there is not enough space for the circular ducts or the air flow rate is too big for the circular ducts. Most of them are used in engine rooms and silencer joints.



**Figure 4.8.** Circular ductwork



**Figure 4.9.** Rectangular ductwork

## Duct components

The ventilation ductwork requires several components such as:

- Vent dampers and dampers
- Air flow rate gauges
- Fire dampers
- Silencers
- Cleaning hatches

Vent dampers and dampers are either circular or rectangular. Vent dampers are equipped with the damper position indicator and the dampers with adjusting scale. The dampers are also normally used as the reliable flow gauges for the air flow as long as the installation follows the instructions given by the manufacturer on the distances of the flow disturbance sources to the damper. The air flow rate measurement result is obtained based on the damper adjustment and pressure differential measurement.

Ducts can also be equipped with separate gauges whose measurement results can be obtained based on the pressure differential measurement.

Fire dampers operate as fire and smoke limiters in accordance with the guidelines defines in Finland's construction regulation collection's part Fire safety. The fire dampers are classified either as class E, i.e. fulfill the tightness requirements or class EI, i.e. fulfill the tightness and insulation requirements and for certain number of minutes for example, E 60 and EI 60. They are shut off by means of a thermal fuse and a spring or an actuator, which is controlled by means of thermal detector or smoke detectors or by external control.

## Insulations

Insulation of the ventilation ducts is divided into four main groups:

- Fire insulation
- Thermal insulation
- Condensation insulation
- Soundproofing

Fire insulation is usually carried out using mineral wool mats, chutes or slabs approved to the instructions in the Finland's construction regulation collection's part Fire safety. Insulations are usually covered with aluminum laminate and with sheet metal if there is a risk of breakage of the insulation. The fireproofing requirement may be for external or internal fire. The principles of fire insulation are described in standard EN 13661-1 and fire classes of the insulations in standard EN 13501-1.

The function of thermal insulation is to prevent the heating or cooling of flowing air in the duct to prevent possible condensation and fogging on the outer or inner surface of the duct. The choice of insulation and the dimensioning of insulation thickness is influenced by the temperatures in the duct and in the surrounding space. The insulation thicknesses of the supply air ducts are usually 30 to 50 mm according to the duct size and 80 to 120 mm for the outdoor air and exhaust air ducts. Extract air ducts are generally not insulated.

Thermal insulation is usually carried out using mineral wool mats, chutes or slabs. The insulations are usually covered with aluminum laminate and with sheet metal if there is a risk of breakage of the insulation. In some cases, a diffusive solid foam insulation can also be used as a condensate insulation. In this case, surface layer requirements for fire safety should be considered.

Soundproofing can be executed in ducts with mineral wool made for this purpose, which is internally coated so that it doesn't release the insulation fibers.

## Supporting

Standard SFS-EN 12236 defines the durability requirements for suspensions and supports for ventilation ducts. Attaching the supports should withstand the corresponding strain.

The supporting must withstand:

- Duct with accessories and supports, insulation material and coating loads
- Safety considerations, the weight of one or more cleaning person
- Other loads (cleaning and maintenance)
- Possible vibration
- Corrosion

The ventilation ducts must be at least the same class as the fire resistance requirement of the duct. **Figure 4.10** presents the most common examples for supporting circular and rectangular ducts.

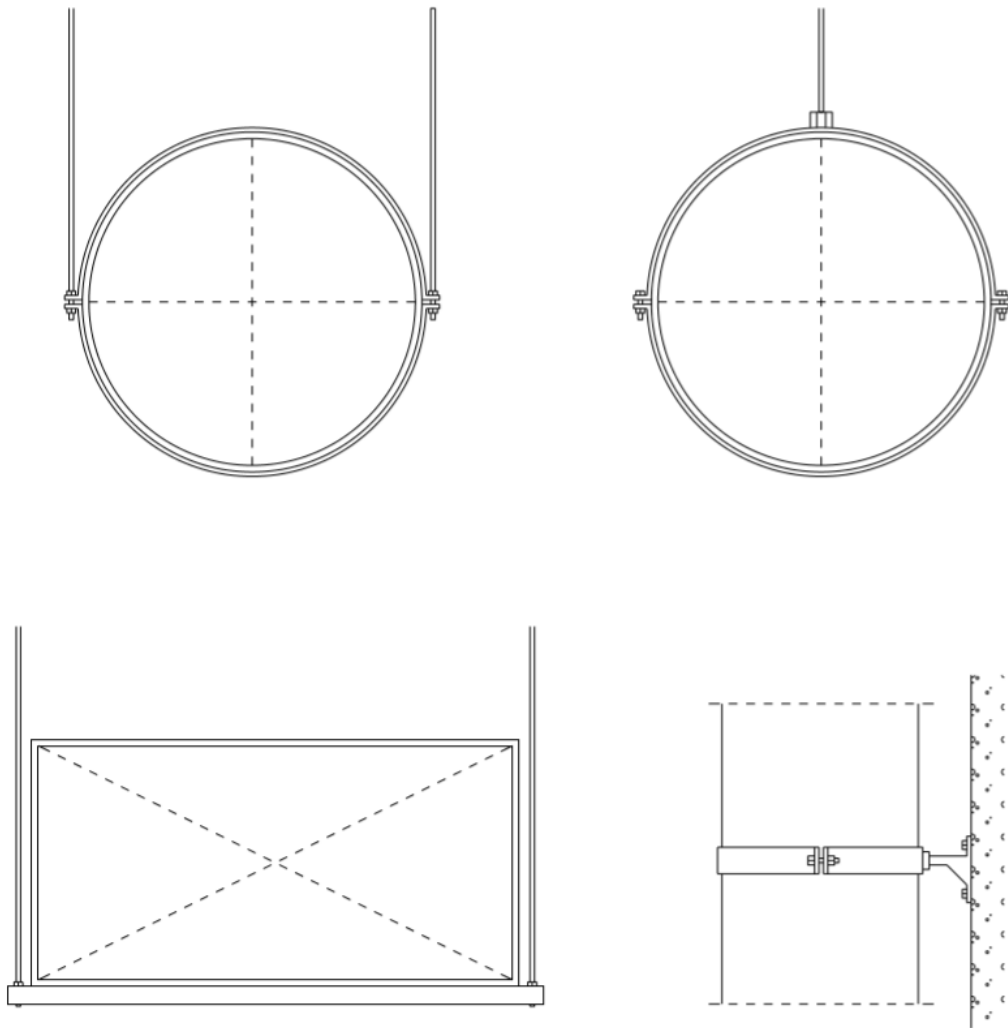


Figure 4.10. Different supporting methods for circular and rectangular ducts

## 5 TECHNOLOGY

Air distribution method and air handling unit have great significance for ventilation and the air quality produced by them. Air distribution can affect to felt thermal comfort and people's overall comfort. The function of the air handling unit is to make the distributed air clean, comfortable and healthy, and to produce the air movement in the ventilation system.

This section handles mainly machineries, applications and equipment according to ventilation and air conditioning. Sections shows different methods to implement ventilation various methods and which method fits for which application. The section also tells about air handling units and various parts of the air handling unit and their tasks.

### 5.1 Air handling unit

Air handling units can be divided according to many criteria, because of in the last decades has been used many different applications and machineries. One way to divide air handling units is presented on below. Presented way is based on machinery structures, equipment and applications used on today.

- Small air handling units
- Enclosed air handling units
- Operational air handling units
- Separated fans

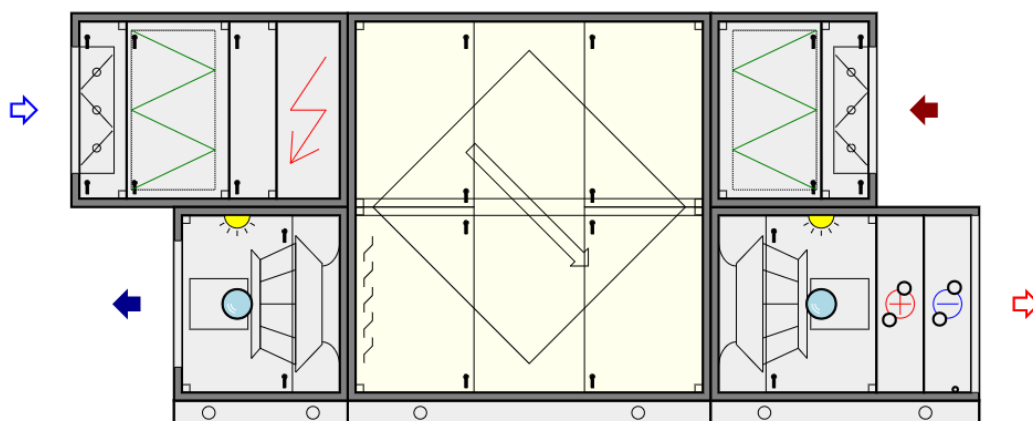


### **Small air handling units**

Mostly used in detached houses, apartments, split systems and small buildings. Mounting-ready units, which contains electricity and automation. Small air handling units are made mostly for detached houses and terraced houses, and for split system executed block of flats. Some appliances are used in small individual office premises and stores. Small air handling units are standard products whose delivery time is short. It has been used also at schools for serving individual classrooms. Nominal air flow rate value is usually between  $50 \text{ dm}^3/\text{s}$  and  $500 \text{ dm}^3/\text{s}$ .

### **Enclosed air handling units**

Enclosed air handling units are installed indoors. System is centralized and the air handling unit has different module options. The modules are delivered according to need of building and its ventilation. Electricity and automation are installed by a specific contractor. Internal electricity is possibly pre-installed already in factory. By far the most used air handling unit in every type of buildings, except for detached houses and terraced houses. The enclosed air handling unit is usually placed into air handling unit room which usually locates on the highest point of building. The machinery is possible to place into served space, if there is no possibility or need to have separate air handling room. In this situation, sound technical effects must be considered. Nominal air flow rate value is usually between  $0,5 \text{ m}^3/\text{s}$  and  $25 \text{ m}^3/\text{s}$ .



**Figure 5.1.** Enclosed air handling unit (FläktWoods Acon, Air handling unit selection program)

### Operational air handling units

Operational air handling units can be installed indoors, outdoors and in one or two pieces. Electricity, automation and pumps are pre-installed in factory. The operational air handling units suits for a fast installation. The operational air handling units can be indoor or outdoor suitable machineries. The outdoor installed appliances are in the same time engine rooms with maintenance space. Roof installed appliances are also known as rooftop units. Assets of the operational air handling unit is faster installation time in the building site, reduce of auxiliary works, reduction of inspections and test runs in the building site. Mechanical function is same as in the enclosed air handling units.

### Separated fans

Separated fans are for example extractor fans, axial fans, duct fans and centrifugal fans. The separated fans are used for individual services such as exhaust air fan, supply air fan, jet fan, smoke extraction fan, transferred air fan and process fan. The separated fans are appliances which are not usually attached straightly with other functional parts. Sometimes fan is attached with vent

damper. The most typical way in ordinary ventilation system, is to use separated fan as an exhaust fan, if exhaust air is not possible to lead into an air handling unit because of impurities of the air or some other reasons. The separated fans are also used in special applications like smoke exhaust and industry process. These types of fans are roof exhaust fans, axial fans, duct fans and centrifugal fans.

The centrifugal fans suit well for a wide air volume and pressure area except for small pressure raises, while the axial fans are good for big air volume flows and small pressure raises. The duct fans are typically for a small air flow rates. The efficiency of the axial fan, which in simple models is far smaller than the standard centrifugal fan, could be raised with help of diffusers or some other attachments.

Extraction fans are commonly used as exhaust air fans in almost all types of buildings. They are positioned to point up on top of the roof of building. The extraction fan is a direct drive radial fan with a vertical shaft and motor.

Typically used applications are waste air extractions, which can't be combined with a central air handling unit due to impurities contained in the waste air. These include toilets, cleaning closets, social facilities, laundry rooms and bathrooms. The extraction fans are widely used in industrial decks and warehouses, as well as smoke exhaust fans.

When the extractor fan is on top of the roof, the ductwork in the building is on under pressure. Due to under pressure of ductwork, air leakages do not bring any smells into the indoor air. When the extraction fan is located on top of a roof, it doesn't cause any noise nuisance to the served space as compared for example, to a cooking hood in the residential building.



**Figure 5.2.** Extraction fan (FläktWoods)

The use of axial fans is nowadays focused on cooling of the spaces, separated extractions, preparation fans and mechanical smoke removal. The ventilation of parking garages and tunnels has its own models, but the main structure of the fan is similar. The axial fans are also used as pressure fans to secure escape routes.

The axial fan consists of a cylindrical casing and an impeller, which is usually mounted directly to the shaft of the short-circuit motor. The impeller consists of hub and blades that can be fixed or adjustable. By varying the size of the hub and the number of blades, good efficiency and low noise level can be optimized for the desired operation range. The adjustability means that the blade angle is adjustable to match desired performance values (air flow and pressure increases).



**Figure 5.3.** Axial fan (FläktWoods)

## **5.2 Functioning parts of air handling unit**

Task of air handling unit is to handle and prepare the distributed air for a building. The handling involves heating and cooling of the fresh air, transferring heat from warm extract air to chilly fresh air, creating the air movement in ductwork, filtering impurities of fresh air and extract air, and humidification and dehumidification of supply air.

### **Air heater and air cooler**

Heat coils are used in air handling units to heat or cool air. Basic principle is same with the both processes. Task of the coils is to generate maximal heat transfer power with minimal pressure loss. The heat coils consist of lamellas and pipes passing through them. Task of the lamellas is to grow a heat transfer surface and task of the pipes are to carry heat transfer liquid. The lamellas are usually made from aluminum and the pipes from copper. Water of the heating water system is used as a heat transfer liquid in the air heaters and sometimes it's mixed with water-ethylene glycol mixture and in industry with oil, process liquids or steam. Heat transfer liquid of the air coolers is water of cooling water

system, water-ethylene glycol mixture and evaporating refrigerants, but in industry is used also oil and other liquids.

The used heat transfer liquid of the heat coils is usually water, and in this situation the heat coil must be protected with a frost protection. The frost protection sensor is monitoring the temperature of return water in the heat coil. The sensor is giving alarm when the water temperature falls around to 8 °C, in this case automation shuts off the fans and closes the outdoor damper of the air handling unit.

Air heater working by electricity, is used in situations when bringing the heating water to air handling unit is impossible or it would increase costs to unreasonable high. The electric heater has many good features: good adjustment, non-freezing, leakage-proof, no need for pumps etc. Downside is the high price of electrical energy, compared especially to district heating produced energy.

### **Heat recovery**

Mechanical ventilation system must equip with a heat recovery system, which supply air temperature ratio of heat exchanger is at least 55 % in test conditions and when the mass flows of are same between supply an extract airs, and which frost protection and condensed water extraction from extract air is implemented with a reliable way. The heat recovery can be abandoned for part an individual space in the building without reducing comparing amount of energy consumption, if building the heat recovery system is proved to be impractical. (Ympäristöministeriö, 2008.)

Building heat recovery system can be proved impractical for example, when an exceptional impure air is preventing work of heat recovery or temperature of a room is on heating season under +10 °C, nor is not possible to get heat from extract air cost-effectively. (Ympäristöministeriö, 2008.)

Finland's construction regulation collection is regulating following things about thickness of the heat recovery devices and allowable mixing between the extract air classes. The extract air classes are presented in page 66.

Structure and pressures of heat recovery devices must be executed so that an extract air can't mix with a supply air in significant amounts.

While recovering heat from the class 1 extract air, there is no given any requirements for pressure different and direction of leakage air. While recovering heat from the class 2 extract air, pressures of heat recovery device must be planned so that the direction of leakage air is mostly from supply air side to extract air side.

While recovering heat from the class 3 extract air, pressures of heat recovery device must be planned so, that direction of leakage air is from supply air side to extract air side.

In heat recovery devices, where supply and extract air are flowing alternately in the same flowing route, can be only used, if the extract air contains maximum 5 % air from class 3 extract air, and not at all air from class 4. In an apartment of one family it's possible to use regenerative heat exchanger for heat recovery in the air of class 3.

Run around coil heat recovery system must be used while recovering air from the class 4 extract air, because it's prevents mixing between the supply and the extract airs.

If air handling unit is serving only one space, heat exchanger of heat recovery type can be chosen freely, even the extract air can be in the class 3 or 4. In this case, the supply air must to be clean enough to fill requirements of indoor air quality. This sort of spaces is for example industry spaces or garages.

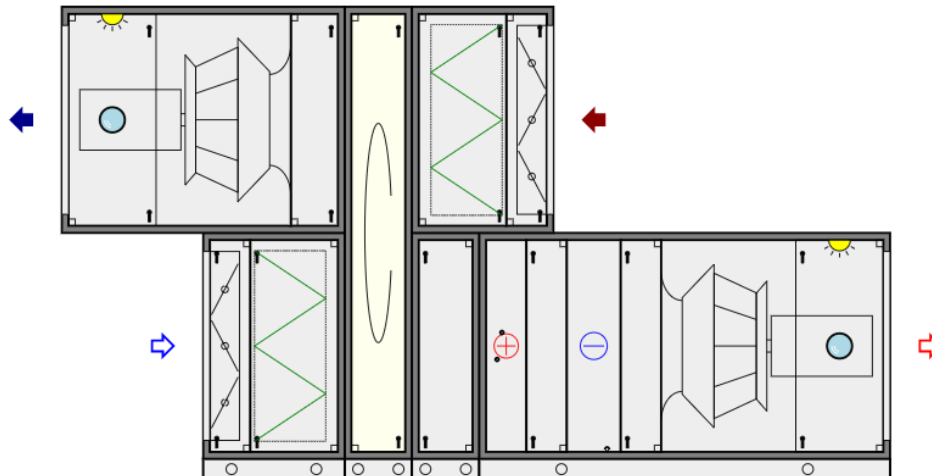
Air handling units have different variations of the heat recovery systems: rotary heat exchanger, cross-flow heat exchanger, counter-flow heat exchanger and run around coil heat exchanger. The right heat recovery system must be chosen according to purpose of use. Selection criteria can be disposable space, humidity transfer, maximum amount of mixing extract and supply air.

### **Rotary heat exchanger**

Rotary heat exchanger consists of disc-like rotor and operating machinery. Casing of rotor is divided for two halves; other half is for supply air and other half for extract air. Rotor is transferring heat from the extract air to the supply air while it's turning around. The rotor consists of cell structure, made from thin aluminum sheets or ceramic material. The rotor is working with counter-flow principle and without medium matter, and because of this it has high efficiency. The heat is not transferring through of any material, because the heat is retained in to the cells of rotor in extract air side and after the rotor turns 180° to the supply air side, the heat transfers in to the cooler supply air. Change between the direction of air flows helps to keep rotary heat exchanger clean, because impurities are blown away from cells on every full turn. Due to clean counter-flow heat exchange and big heat exchange area, achieved heat efficiency is typically in between 75 % to 85 %.

The rotary heat exchanger is the most used heat recovery system. It's always used when it's possible for space requirements and air purity. When the air handling unit serves only one space, the rotary heat exchanger can be used to exchange heat from very dirty space.

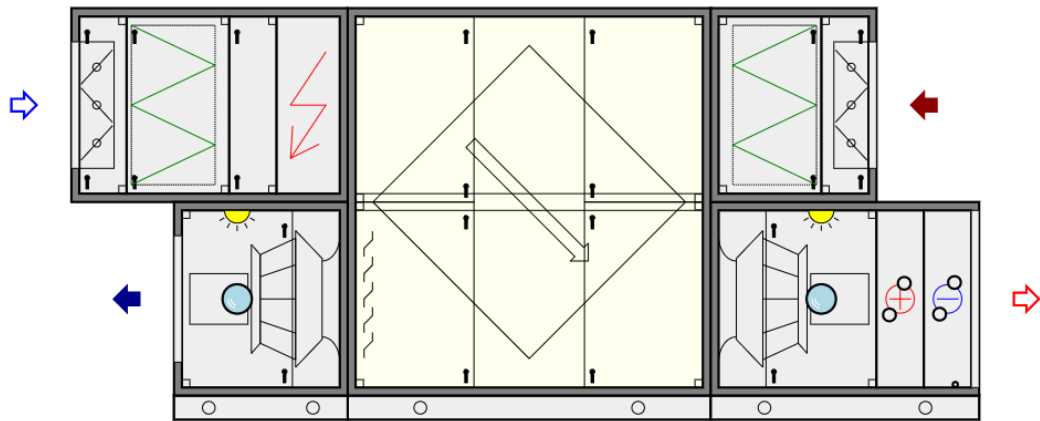




**Figure 5.4.** Air handling unit with rotary heat exchanger (FläktWoods Acon, Air handling unit selection program)

### Cross-flow heat exchanger

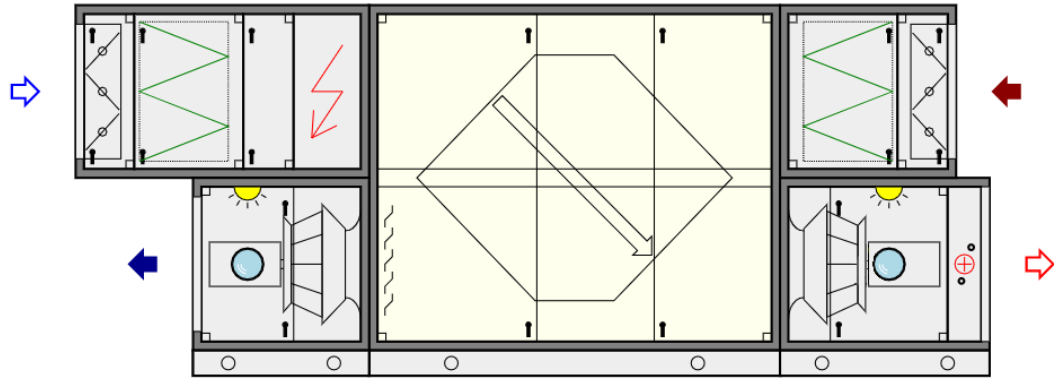
Cross-flow heat exchanger is numerically the most used heat recovery system in ventilation. It's the most common in detached houses. It's popularized by the cost-effective structure, hygiene and pretty good heat recovery efficiency. The cross-flow heat exchanger consists from set of square sheets. Air is flowing crosswise between the sheets, in a such way that in every other gap flows chilly supply and every other gap warm extract air, and the heat is transferring through the sheets. The sheets are thin and made from materials which has good thermal conductivities. Structure of the cross-flow heat exchanger is possible to manufacture really thig of the leakages. The air leakages can be less than 0,5% with pressure difference 400 Pa. The cross-flow principle also limits the achievable economic maximum efficiency, which is in between 60 % to 65 %. The plate heat exchanger is very reliable, because no moving parts are needed for the actual heat transfer.



**Figure 5.5.** Air handling unit with cross-flow heat exchanger (FläktWoods Acon, Air handling unit selection program)

### Counter-flow heat exchanger

Counter-flow heat exchanger has almost similar structure than the cross-flow heat exchanger, only the air flows are flowing more opposing directions. This modification gives significant improvement for heat efficiency. The heat efficiency can be around 80 %. High temperature ratio means that the extract air cools down and in the case of humid extract air, the counter-flow heat exchanger is much more sensitive to the fog than the cross-flow heat exchanger. For this reason, defrosting must be carried out with care. In some cases, besides defrosting, a preheating coil is required to heat up chilly outdoor air.



**Figure 5.6.** Air handling unit with preheating coil and counter flow heat exchanger (FläktWoods Acon, Air handling unit selection program)

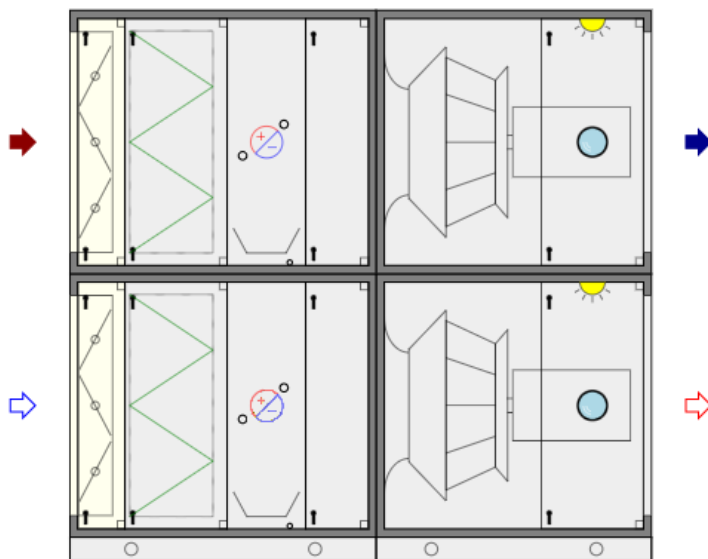
### Run-around coil heat exchanger

Run-around coil heat exchanger transfers heat along a medium matter, usually along a circulating fluid. Extract air side and supply air side have both the own heat exchanger. Structure of heat exchangers are similar as heating coil and cooling coil. The heat transferring happens from air to fluid in the extract air side and from fluid to air in the supply air side. Circulating fluid is usually mixture of water and de-icing fluid. Ethylene glycol can be used as the de-icing fluid and sufficient concentration of the de-icing fluid in the water is 15 %, but typical concentration is in between 25 % to 30 %. Concentration of the de-icing fluid is kept low as possible for better heat transfer features. Typical heat efficiency is around 50 %.

The run around coil heat recovery system has many redeeming features, which sets it apart from the other heat recovery systems:

- There are no possibilities for any air leakages, because of supply air and extract air are fully separated from each other. This enables using it in special spaces, like surgery rooms, laboratories, clean rooms etc.

- Can be used in ventilation systems where extract air ducts and supply air ducts stand far from each other. For example, in big parking garages where supply air stands on different side of the hall than extract air.
- Installation is quite simple to do for existing system. The need of additional space is small and places of air handling units or ducts doesn't need to be changed.



**Figure 5.7.** Air handling unit with round-around coil heat exchanger (FläktWoods Acon, Air handling unit selection program)

## Fans

The main component of the fan is the motor and the impeller. When the impeller rotates, the wings work in the air so that the air flow rate and pressure increases. The pressure loss caused by the air flow in the duct always corresponds to the fan generated pressure increase, i.e. the fan always positions itself to the equilibrium with the duct. The fan increases the total pressure of the air flowing through the impeller. The total pressure consists of static pressure and dynamic pressure. The contribution of dynamic pressure is intended to minimize, because it causes noise, and reduced losses before a part of it

changes to a static pressure. For this reason, the fans are designed so that the dynamic pressure is to be converted to static pressure near the outer edge of the impeller and in the fan casing.

The desired air flow rate of the fan is set to the desired position by adjusting the fan rotation speed. This is done either by selecting the suitable gear ratio of the belt drive or by adjusting rotational speed of the motor with the frequency converter.

Mostly is used three types of fans motors: short-circuit motor, EC-motor also known as electrically commutated motor and PM-motor also known as permanent magnet motor. Efficiency of short-circuit motor is relatively good, except for on lower motor powers. The EC-motor has a better efficiency than the short-circuit motor, as well as the PM-motor which has a significantly higher efficiency, especially with low engine power.

### **Plug fan**

The plug fan has an impeller with backward-curved blades without fan casing. Its performance resembles the cased fan values, but it lacks the static pressure rise in the fan cover. Therefore, the efficiency of the plug fan is lower than corresponding fan with a fan casing. Structure of the wheel of plug fan generates an expanding diffuser, which contributes to reducing this deficiency. From the fan wheel, the air comes directly into the chamber where the blower is located. In the chamber, the air velocity decreases and the next function part can be located very close to the fan.

The plug fan is direct drive, so the fan wheel is mounted directly on the motor shaft. There are several benefits of this, which is why the plug fan has almost completely displaced the cased radial fan in the air handling units. The plug fan lacks belt drive, which needs maintenance and releases rubber dust. For this, the plug fan is more hygienic and easier to maintain and clean due to its open

structure. Belt drive also causes power loss to power transmission. Especially with low air flows and electric power, the belt drive efficiency may be very poor. The direct drive makes balancing of the fan easy, because the fan, motor, and its mounting pad are balanced as a one package.

The plug fan requires generally always the frequency converter control.



**Figure 5.8.** Plug fan (FläktWoods)

### **Cased radial fan**

Cased radial fan also known as centrifugal fan was in fact the only used fan type in air handling units before the propagation of the plug fans. **Figure 5.9** presents a typical belt-driven radial fan. The spiral-shaped casing of a radial fan acts as an optimal diffuser, changing the energy of air flow velocity to static pressure. Therefore, this type of fan achieves high efficiencies.



**Figure 5.9.** Radial fan with spiral-shaped casing (FlätkWoods)

The maximum efficiency of the cased radial fan used in air handling units is about 85 %. The fan is suitable for all kinds of air flow rates, but especially for very high air flow rates where the need of electrical power and efficiency are in significant importance. The efficiency is weakened by the belt drive required for power transmission, but the efficiency of belt drive is also very high at higher power levels.

### **5.3 Air distribution methods**

The implementation of air distribution method has a big effect for people's well-being and experienced indoor air quality in a space. The air distribution method implemented for users is succeed, as far as air distribution, ventilation and air conditioning stays without any special attention. Dysfunctional or badly planned air distribution can cause draught problems, noise and complains about air quality, which are impairing peoples' satisfaction and performance. Particularly, attention should be paid to the air distribution planning in the premises, as there are large cooling powers which causes risk of draught, and hence discomforts for a user.

### **Air conditioning strategy**

The starting point for planning is to consider the specific features of the space and to plan the principles of room air conditioning strategy in such a way that the chosen indoor climate class is executed. Particularly, attention should be paid to the air velocities at various point in the occupied zone.

The first step in determination and planning a room air conditioning strategy, is to gather basic information from the building. Basic facts to find out at the beginning of planning should be:

- Target values of room conditions (room air temperature, maximum velocity of air and indoor air quality)
- Room width, length and height
- Architectural requirements
- Thermal loads and their locations
- Sources of pollutants and their locations
- Heat losses as well as window structures and exterior doors
- Placement possibilities of supply and extract air devices
- Possible barriers for air jet
- Necessary pressures in the surrounding spaces
- Total air flow rates

The choosing of the room air conditioning strategy is a multi-step process in where with help of basic data is selected:

- Air conditioning system, space heating and cooling power
- Supply and extract air flow rates
- Air distribution method
- Supply air temperature and potential air flow control method
- Type and location of supply and extract air devices
- Size and number of supply and extract air devices



Space-specific supply and extract air flow rates are determined in such a way that the desired indoor air quality, cooling power and pressure ratios are achieved. In the premises, often the outdoor air flow rate is the same as the exhaust air flow rate and the supply and extract air flow rate are equal. In this case, the supply air flow rate is selected according to which of the following factors lead to the biggest air flow rate.

- Chosen indoor climate class
- Needed cooling and heating power
- Extraction of humidity loads

Air distribution methods have different grouping styles. The most commons are to divide them in to:

- High velocity and low velocity air distribution method or to;
- Mixing, stratification and piston air distribution method

In the high velocity air distribution method, supply air is blown at high velocity, whereby the room air is blended into the air jets. In the low velocity air distribution method, supply air is blown at low velocity. Convection flows caused by the thermal load of the room, are controlling the room flows.

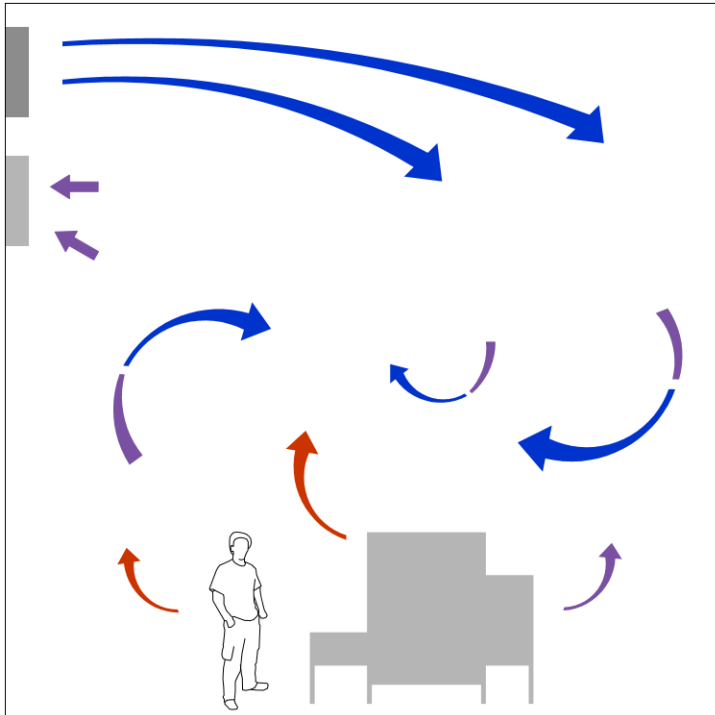
In the mixing air distribution method, supply air is blown in to space so that content of impurities is decreasing and temperature is stabilizing. In the stratification distribution method, supply air is blown so that impurities and temperature are stratifying. Supply air is replacing air rising by convection flows. In the piston distribution method, big supply air flow rate is blown with low velocity for a wide area.

### **Mixing air conditioning strategy**

Target of mixing air conditioning strategy is to mix air effectively and keep temperature and impurity conditions same in the whole room area. This method is mostly used in the common spaces, but also in industry. The method is functional when thermal load is relatively small and forming of impurities is low. Room air flows is controlled with a high velocity supply air jet and temperature of the supply air can be quite low compared to room temperature. The method is the most common in low areas and easy to implement. In a high areas air distribution and air mixing must be considered, especially when the area is heated up with the supply air.

Characteristic features of the mixing conditioning strategy are the following:

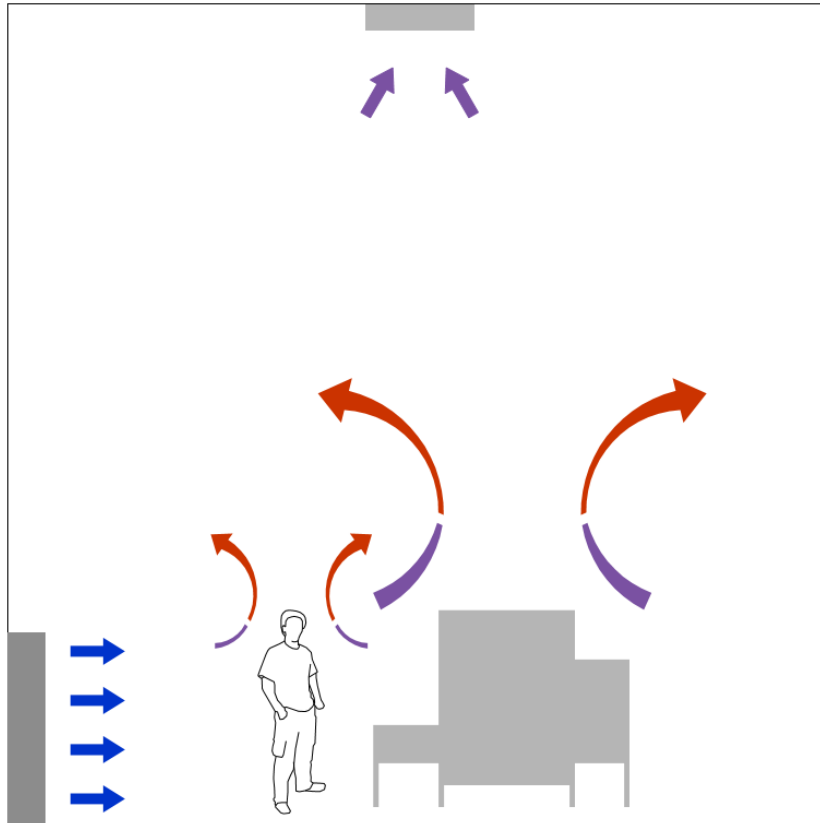
- The room temperature and impurity levels are the same throughout the space
- The air velocity from the supply air device is high between 1,5 m/s to 10 m/s.
- The attaching (coanda effect) of the air jet to the ceiling and the walls is utilized to the control the trajectory of the air jet
- The supply air temperature is typically in between 5 °C to 10 °C below the room temperature



**Figure 5.10.** Mixing air conditioning strategy

### **Stratification air conditioning strategy**

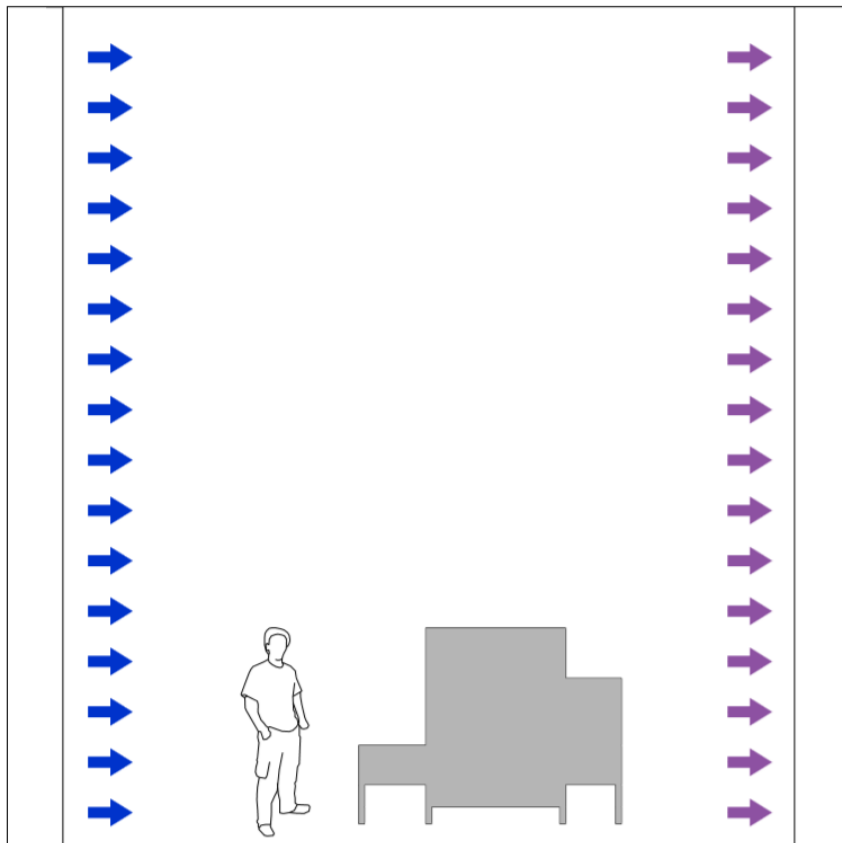
Stratification air conditioning strategy is striving to stratification of air in the space. Stratification happens when supply air device supplies chilly air with a low velocity into the space and the chilly air accelerates because of the upthrust force. The density difference between chilly and warm air creates upward convective flows know as thermal plumes. The thermal plumes are creating stratification between different temperatures and impurities. Stratification air conditioning strategy is mostly used when impurities are formed about in the same source than the thermal loads. In the spaces, typically these kind of impurity sources are humans, so target of applications can be classrooms, conference rooms, theaters etc. The stratification air conditioning strategy is widely used in an industry, where machines are producing a lot of impurities and thermal loads.



**Figure 5.11.** Stratification air conditioning strategy

### **Piston air conditioning strategy**

Piston air conditioning strategy is aiming to at an evenly variable distribution in the direction of the air flow, in which room air flows are controlled by a parallel low-speed supply air which is sufficiently strong enough to overcome the interference flows. The piston air conditioning strategy is used in spaces where are specific requirements for the air quality, such as clean rooms and operating rooms. The air flow rate is typically big.



**Figure 5.12.** Piston air conditioning strategy

### Zoning air conditioning strategy

In the zoning air conditioning strategy, air is mixed only to a certain level of height and above this level the room temperature and impurity is given to stratify. In the controlled zone (usually occupied zone, see **figure 3.6**) the conditions are wanted to be controlled and in the uncontrolled zone the temperature, impurities and humidity is wanted to stratify. Room flows are controlled by both the supply air and the effect of the upthrust force. The non-thermal air of the supply air may be chiller than the air in the controlled zone. The human convection flow is not sufficient to cause stratification in the zoning air conditioning strategy, but lighting, machinery and equipment can cause it.

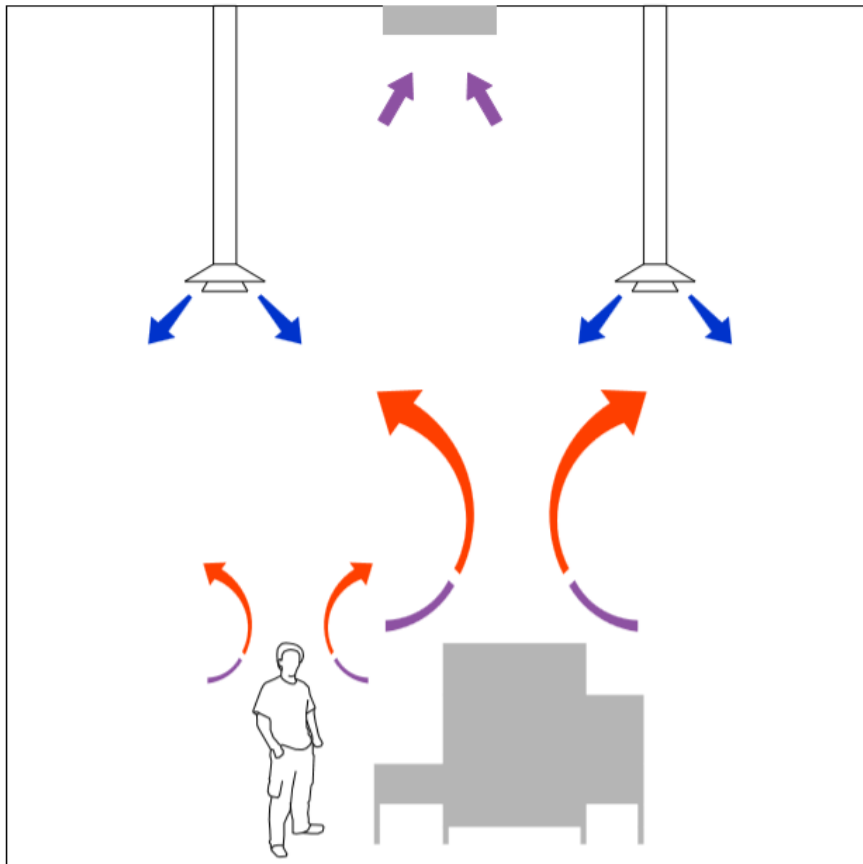
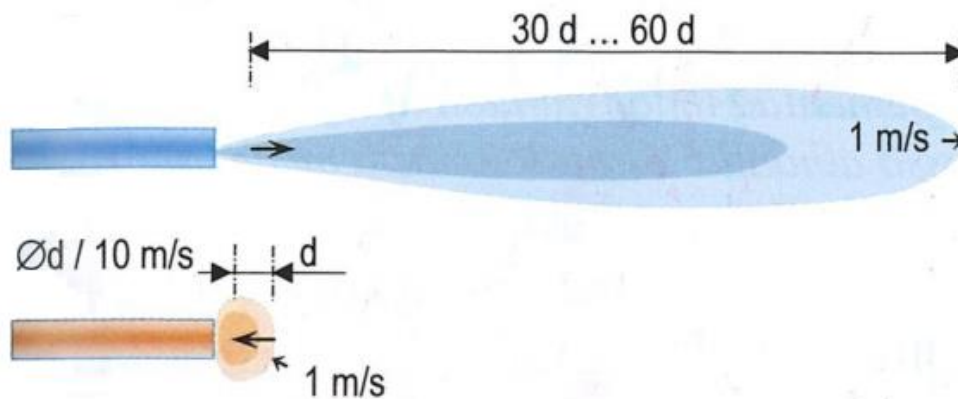


Figure 5.13. Zoning air conditioning strategy

### Extraction strategies

The room air flows can be easily influenced by supply air stream, but influencing air room flow with extract air stream is more difficult. **Figure 5.14** presents the difference between supply air stream and extract air stream.



**Figure 5.14.** Difference between supply air and extract air streams (Sandberg, 2014)

The main principles of the placement of extract air device are:

- Impurities from their sources are attempted to remove with local extractions, to prevent impurities from spreading into the room. Usually, they also involve removing the thermal loads. Typical local extractions include cooking hoods in the residential buildings, hoods and scoops in the professional kitchens, fume hood in the laboratories, sawdust removal in the wood industry, and hoods in the welding and process industry.
- The extract air device of room is placed near the ceiling because the heat tends to stratify up owing to the convection streams and impurities with them.
- The extract air devices of room are placed mainly where the impurities are most generated to keep the room air flows from cleaner room to the dirtier room. For example, in the residential buildings the extractions are centered to hygiene facilities like toilet, sauna, walk-in closet and kitchen.
- Extract air devices are generally not required as many as supply air devices. This is based on the fact that in the mixing air conditioning strategy the temperatures and the concentrations of the impurities are relatively even. In stratification and zoning

air conditioning strategies, in top of the space the air is flowing to the extract air devices.

### **Variable air volume system (VAV)**

Air flow rates and needed heating and cooling powers in the buildings is dimensioned for the people and for people's well-being, but while the building isn't under the use, the ventilation systems are doing unnecessary work and because of this, spending unnecessary energy. Over dimensioned ventilation situations are causing a lot of waste energy by fans and heating and cooling systems. Therefore, buildings with a significant difference in utilization rate during the time of day, is equipped with the variable air volume system. This kind of buildings are usually office buildings, day cares, school buildings, stores, restaurants, sport centers etc.

The variable air volume system is typically space-specific, so each space has its own air flow rate control. If the thermal load is mainly solar load and the internal thermal loads are small, the system can also be implemented zone-specific. If the system only serves one space, the air flow rate adjustment can be machine-specific.

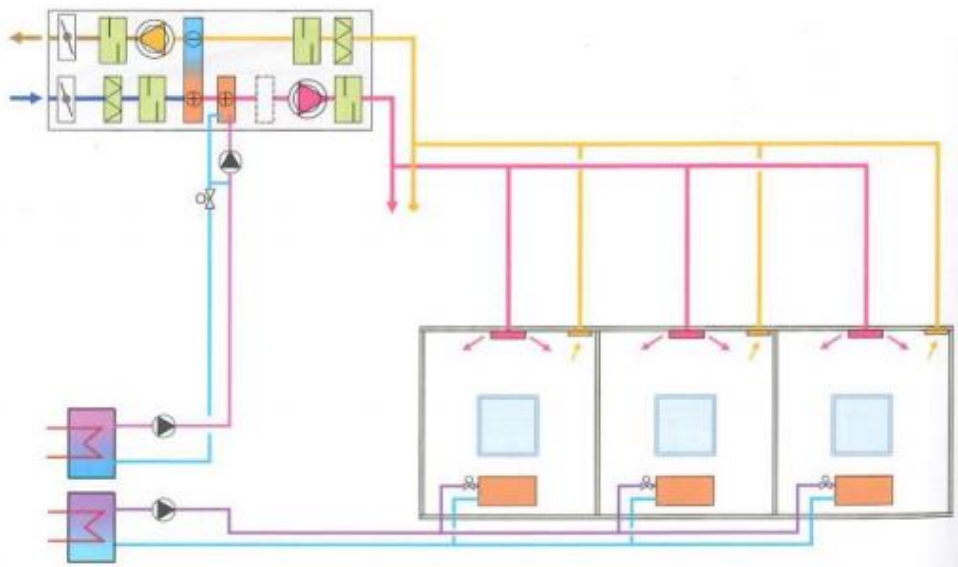
The air is flowing to the room unit of the system with constant temperature, which is chiller than the room temperature in all season. The room temperature control happens by changing the air flow rate, as the air flow rate increases, the cooling power increases. If the loads of adjacent rooms are very different, the room unit of the system is equipped with a preheating radiator so that the air flow temperature can be kept optimally in view of the room requirement.

The controlling of variable air volume system occurs of carbon dioxide levels, temperatures and presence of persons in the space. The system detects the need of controlling with thermal sensors, CO<sub>2</sub> detectors and motion sensors.

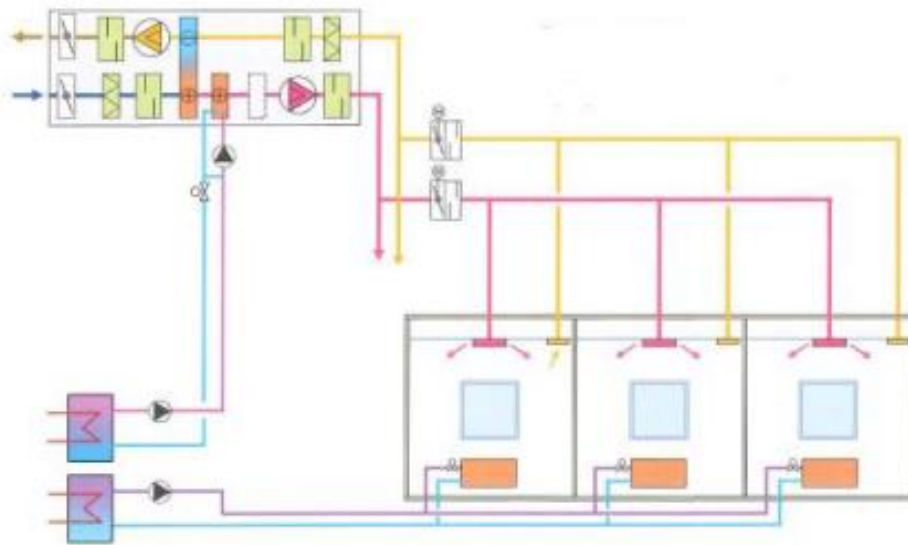


The system is also controlled with predetermined time schedules and manual switches.

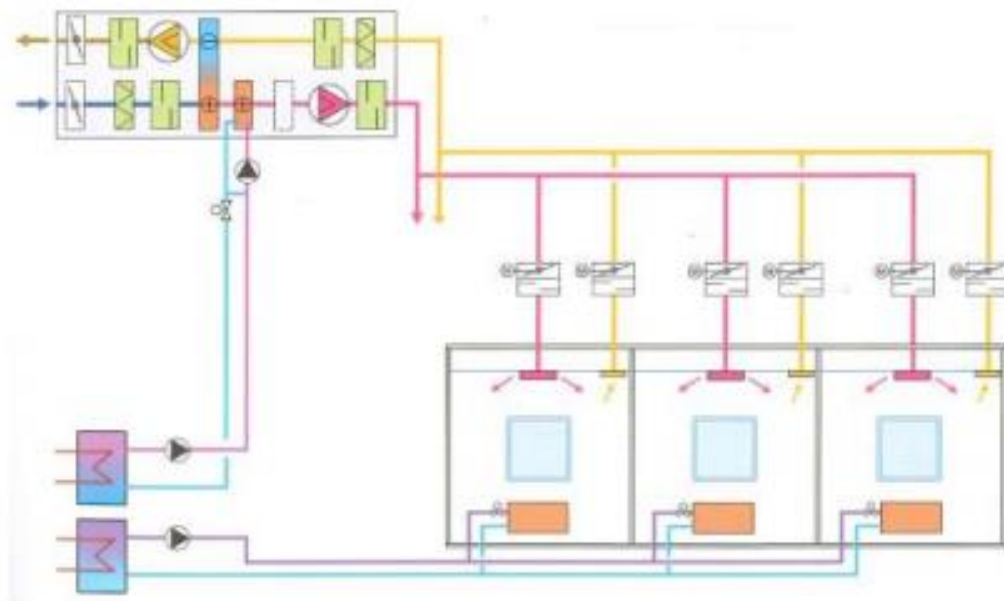
In the zone-specific implemented variable air volume system, control devices are placed before the controlled zone, in which case adjustment of the control devices are according as the need of the air flow rate in the entire zone. In the space-specific implemented variable air volume system, control devices are placed before the controlled space, in which case adjustment of the control devices are according as the need of the air flow rate in the space. **Figures 5.16** and **5.17** are presenting these situations and **figure 5.15** is presenting constant air volume system (CAV) where the air volume is constant despite of the persons' presence or any sensor measurement result.



**Figure 5.15.** Constant air volume implemented air conditioning system (Sandberg, 2014)



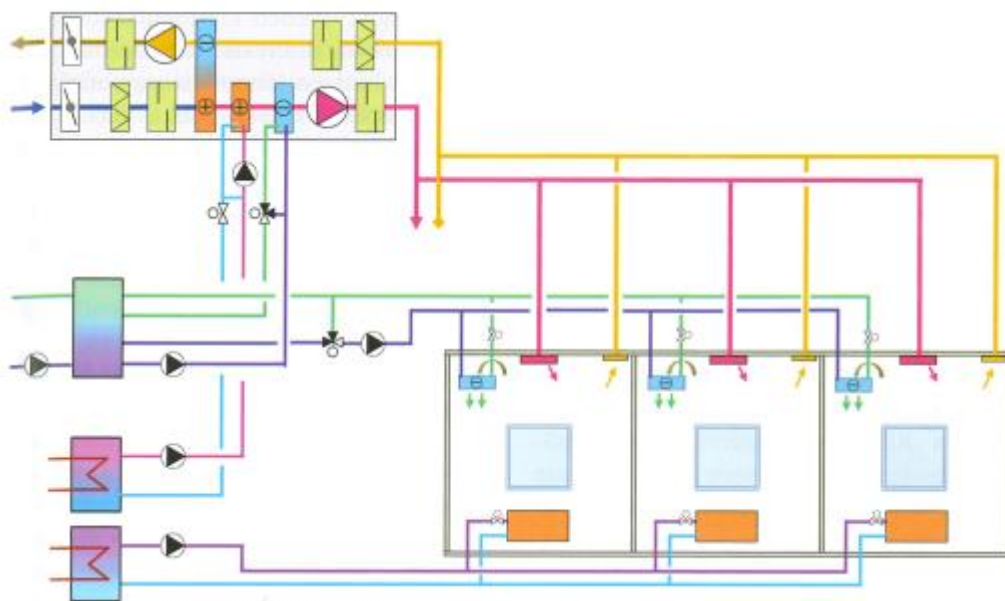
**Figure 5.16.** Zone-specifically implemented variable air volume system (Sandberg, 2014)



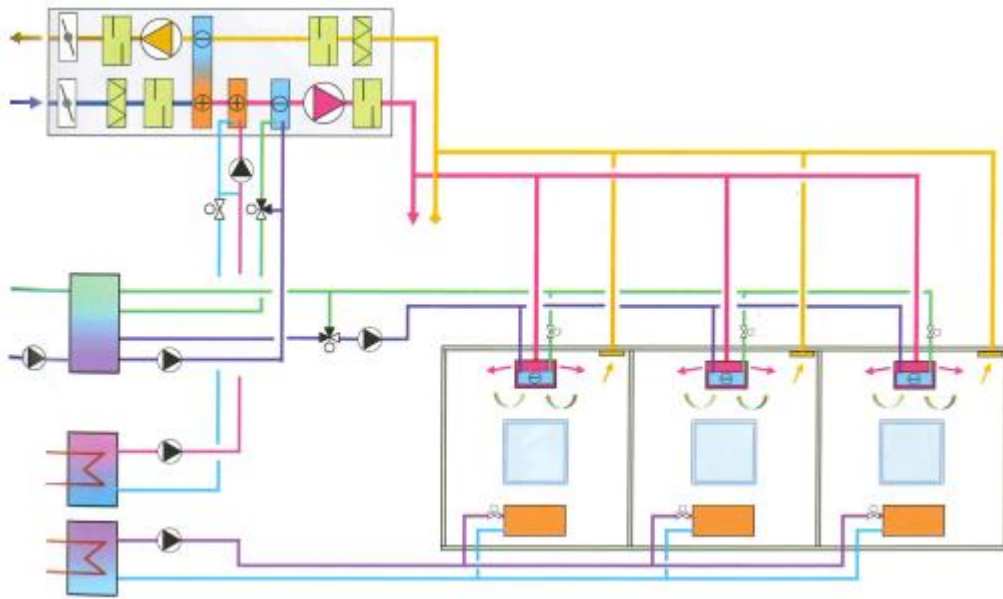
**Figure 5.17.** Space-specifically implemented variable air volume system (Sandberg, 2014)

## Chilled beam

Chilled beam system also known as climate beam system enables high quality air conditioning to individual space. Main module of the system has filtration, heat recovery, heating and cooling function. The cooling water for chilled beams is usually produced with water cooler. Water temperature in chilled beams is in between 15 °C to 16 °C, when humidity of indoor air cannot condense on room devices (radiators, pipes, control valves). The chilled beams are installed underneath of suspended ceiling or ceiling. Extract air devices are placed on the wall or ceiling. Heating of the room is usually executed with radiators, but beams are also possible to equip with heating function. **Figures 5.18** and **5.19** are presenting different chilled beam systems. In the **figure 5.18**, the air conditioning is executed with passive chilled beams, where supply air is blown with separated supply air devices. In the **figure 5.19**, the air conditioning is executed with active chilled beams, where supply air is blown through the chilled beam.



**Figure 5.18.** Passive chilled beam system (Sandberg, 2014)



**Figure 5.19.** Active chilled beam system (Sandberg, 2014)

Air flow rate of the space and the chilled beam is dimensioned by needed outdoor air flow rate for the users and the needed cooling power is determined by thermal loads of the space. Preparation level (dehumidification) of the supply air is also affecting to the required cooling power.

Flexibility of air conditioning is achieved easily with chilled beam system. Supply air flow rate through the chilled beam can be changed in reasonable amounts. If the cooling power of the room is desired to be increased, more chilled beams can be installed in the room.

The chilled beams are suitable to spaces where thermal loads are big and air flow rates are small. This kind of spaces are for example offices, stores and hotel rooms. The chilled beams cannot be placed into humid spaces, because of condense risk. User of the room can control temperatures from the room with a control device placed in the room.

Heat transferring of the passive chilled beams, happens mostly with help of convection and partly with radiation. In cooling situation, warm room air goes into the beam from upper side and comes out underneath of the beam. The

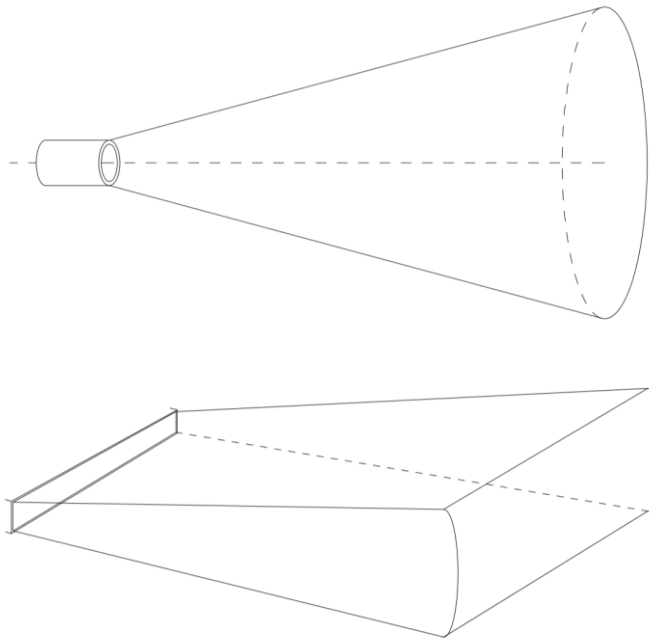
heat transfers to chilly water running in pipes and then the chilled air falls underneath the beam. The heat transferring of the passive chilled beam happens 80 % with convection and 20 % with radiation.

The active chilled beams are connected to supply air when heat transferring is more effective than in the passive chilled beams. This because, in the active chilled beam convection happens with forced convection.

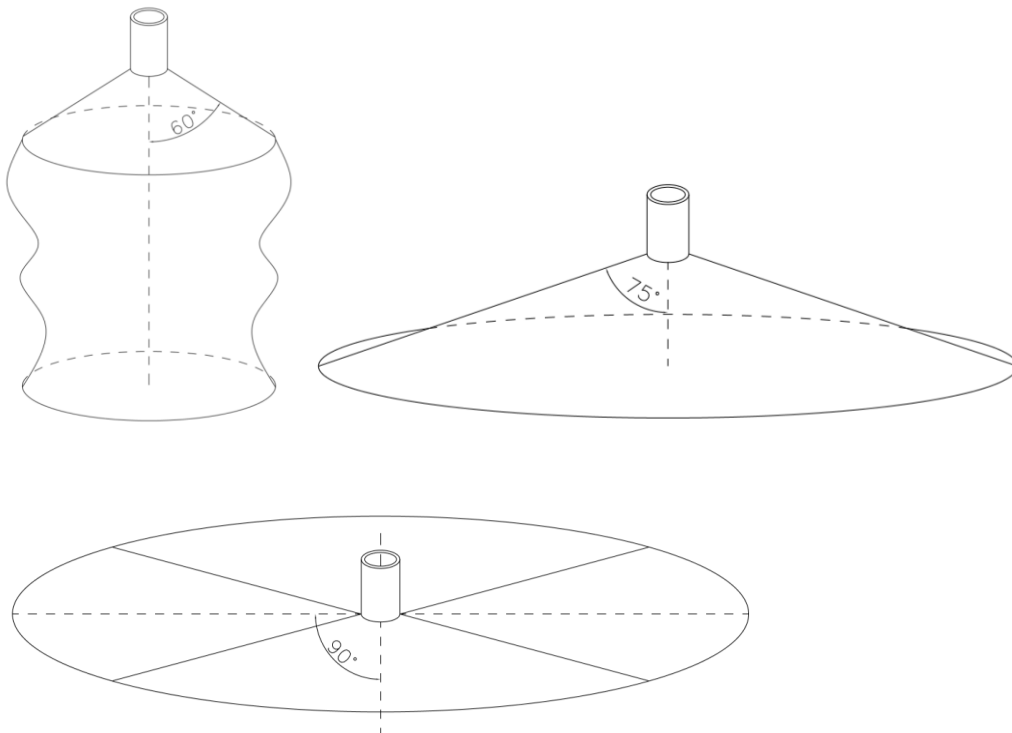
### **Air distribution and extraction devices**

In mixing ventilation, the aim of the air distribution is to effectively mix the room air with the outdoor air flow, thus diluting the concentration of impurities to the desired level. Another objective is to provide the required supply air flow rate to produce the required cooling power. The challenge is to bring the required outdoor air flow rate to the space without causing draught.

The air distribution can be implemented either at high or low velocity. Supply air devices with high air velocity controls the room air flows and supply air jets are causing the air mixing in the room. Instead, supply air devices with low air velocity don't control room air flows. In these cases, the convection flows of thermal load control the flows. **Figure 5.20** and **5.21** presents typical types of air jets for mixing ventilation.



**Figure 5.20.** Axial air jet and planar air jet



**Figure 5.21.** Conical air jets

Supply air devices can be divided to four different classes. These classes are presented in standard EN 12238.

Class 1: Supply air devices with a free air jet

- Nozzle
- Grilles
- Downward blowing diffusers

Class 2: Supply air devices with a radial air jet either along surface or free stream

- Ceiling diffusers

Class 3: Supply air devices with a two-dimensional air jet

- Linear diffusers
- Two-way blowing ventilation beams

Class 4: Low velocity devices

- Displacement diffusers
- Floor diffusers

Another alternative way is to classify the devices according to structure and air velocity:

High velocity devices

- Perforated ceiling diffusers
- Cone diffusers
- Jet nozzle diffusers
- Linear diffusers
- Supply air diffusers
- Swirl diffusers
- Nozzle diffusers
- Grilles

- Nozzle ducts

#### Low velocity devices

- Horizontally blowing low velocity devices
- Textile ducts
- Nozzle and perforated ducts
- Floor diffusers

The supply and extract air device are mainly equipped with plenum boxes for adjusting the air flow rate and balancing the flow so that the devices operate under conditions where their technical features are measured. The plenum box is also capable of absorbing noise and, in conjunction with supply air devices, adjusting the flow pattern of stream regardless of the pressure drop.



**Figure 5.22.** Plenum box with control module and measuring section (Halton Oy)

#### Air diffusion

While considering air diffusion in certain space and choosing a right supply air device, following things of the air outlet should be considered:



- Air pattern
- Throw
- Spread
- Pressure loss

Supply air devices are available with a variety of air pattern options. The layout of the space and available location of the diffuser determines which pattern is selected. The performance of the supply air device and the resultant comfort level in the space are greatly influenced by the type of air pattern selected.

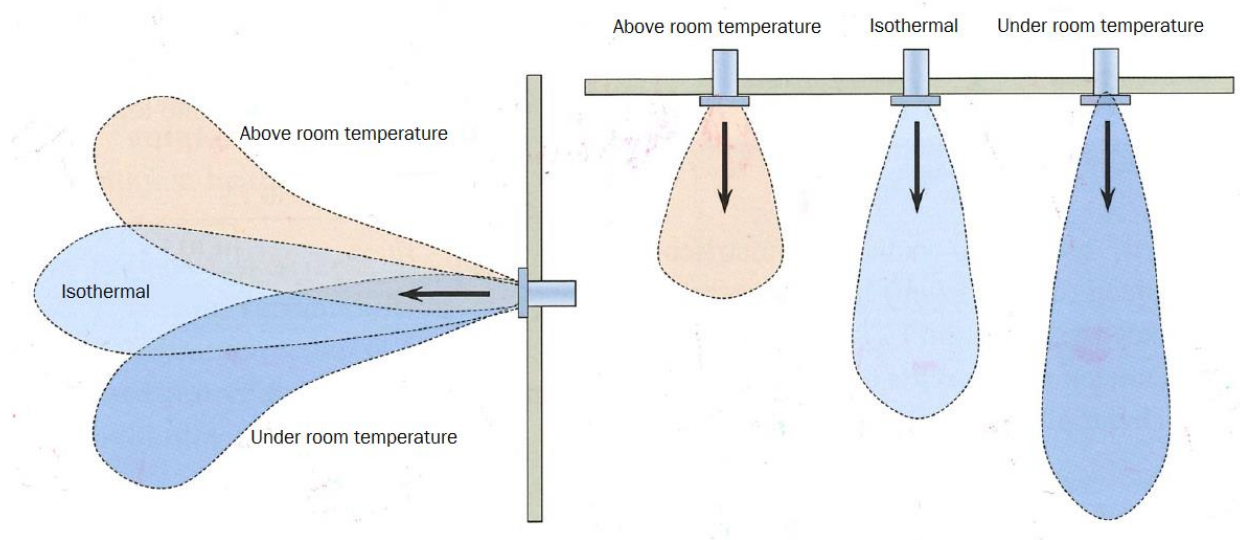
Throw is, by definition, the distance the air is projected out from the center of the outlet face. Throw is primarily a function of the air volume being discharged by the supply air device and the induction rate of the air outlet. The throw can therefore be reduced by decreasing the air flow rate from the outlet or by selecting an air outlet with a high induction rate.

Whenever chilly supply air is introduced into a warmer space its natural tendency will be downward movement. The vertical distance which the air jet extends below the ceiling is called the drop. If the supply air projects into the occupied zone uncomfortable draught will occur. The drop can be minimized by utilizing the surface effect of the ceilings. Air outlets located in or near the ceiling will exhibit less drop than outlets located on exposed ductwork (see **figure 5.24**). Typically, the drop will increase as the air volume, and subsequently the outlet throw, is increased. The vertical spread of the air jet increases with distance travelled. Reducing the supply air volume and increasing the supply air temperature will reduce the drop. One caution regarding reducing air volume too low is that the air jet may detach from the ceiling and fall into the occupied zone.

Spread is the horizontal width of the air jet being discharged by the supply air device. Delivering the air in a spread pattern tends to reduce both the throw and the drop of an air outlet. Dissipating the air jet over a wider area increases entrainment and reduces the mass flow per unit surface area.

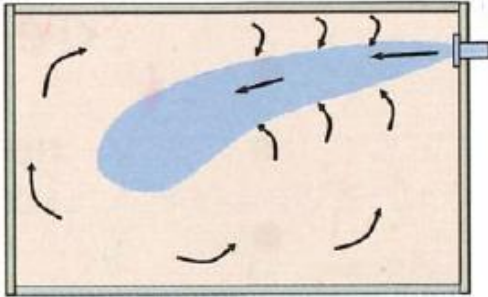
Every air outlet produces a pressure loss when air is passed through it. The magnitude of the pressure loss will vary depending on the model, size and geometry of the air outlet, and is measured in (Pa). Pressure drop will increase proportionally with air flow rate. The pressure drop of the air outlet must be taken into account when calculating the system pressure when selecting the supply fan.

**Figure 5.23** presents effects of air temperature to throw of air jet. Chiller air than room air cause that the air jet is dropping more easily to the occupied zone, thus can cause uncomfortable draught. **Figure 5.24** presents coanda effect where air jet is staying attached to ceiling.



**Figure 5.23.** Effects of air temperature to throw of air jet (Sandberg, 2014)

Cooling situation,  
Coanda effect is not affecting



Cooling situation,  
Coanda effect is affecting

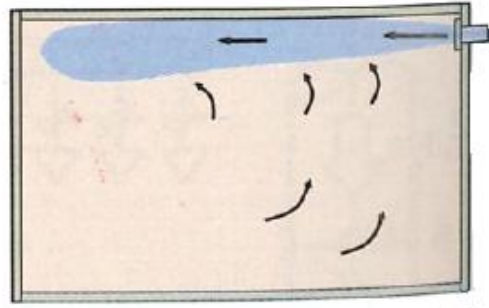


Figure 5.24. Effects of coanda effect (Sandberg, 2014)

## 6 EXAMPLE

Tesoma's coeducational school in the Tesoma city section of Tampere was selected for as an example building to this thesis. In the Tesoma's coeducational school, the old Tesoma's upper secondary school and the Tesomjärvi's primary school were combined into the new building, in addition to a day care center was also built at the school. The number of pupils in Tesoma's coeducational school is about 1000. The project was completed in the beginning of 2018 and the students started in the new school on March 2018.



**Figure 6.1.** Main entrance of Tesoma's coeducational school (PP-Tuote Oy)

Indoor climate of the building was chosen to be class S2, so the indoor air quality in the spaces is good and neither has any distracting smells. Temperatures of the spaces is considered as good and usually draught doesn't exist. The building is connected in district heating.

In the building, the room temperatures are controlled with thermostat on radiators or floor heating. Supply air unit of kitchen has a direct evaporative cooling system. Air flow rates are constant in the building, except of some supply air units which has possibility for intensifying by a CO<sub>2</sub> measurement result or with a time switch.

**Table 6.1.** Dimensioning criterions

Room	Set value of heating	Airflow rate / m <sup>2</sup>
Class rooms	21 °C	3,5 dm <sup>3</sup> /s
Office rooms	21 °C	2,5 dm <sup>3</sup> /s
Lunch rooms and residential rooms	21 °C	5 dm <sup>3</sup> /s
Day care	21 °C	4 dm <sup>3</sup> /s
Multipurpose hall	21 °C	7 dm <sup>3</sup> /s



**Figure 6.2.** Air handling unit room

Below in **table 6.2** is presented air handling units and their serving areas. Table presents also the air flow rate of the machinery and used heat recovery type.

**Table 6.2.** Air handling units, serving areas, air flow rates and heat recovery type

<b>Air-handling unit</b>	<b>Serving area</b>	<b>Airflow rate (m<sup>3</sup>/s)</b>	<b>Heat recovery type</b>
<b>B-section</b>			
TK01	Teaching rooms	5,1	Rotary
TK02	Teaching rooms	4,8	Rotary
TK03	Music teaching	0,7	Rotary
TK04	Lunch room	2,1	Rotary
TK05	Kitchen	1,6	Run around coil
TK06	Social facilities	0,9	Rotary
TK07	Administrative wing	2,1	Rotary
TK08	Technical work	2,6	Run around coil
TK25	B-stair case	0,05	Rotary
PK15	Property maintenance, sawdust extraction	0,1	-
PK16	Ventilated base floor	0,2	-
PK19	Elevator shaft	0,03	-
KK10	Lunch room, circulated air unit of skylight	0,2	-
<b>C-section</b>			
TK09	Teaching rooms	2,4	Rotary
TK10	Day care	1,5	Rotary
TK11	Office	0,5	Rotary
TK12	Lobby, recreation room	1,3	Rotary
TK13	Social facilities	3,5	Rotary
KK03	Lunch room, circulated air unit of skylight	0,14	-
<b>D-section</b>			
TK14	Teaching rooms	3,8	Rotary
TK15	Day care	1,5	Rotary
TK16	Social facilities	0,5	Rotary
TK17	Multipurpose hall, stage	1,4	Rotary
TK18	Toilet	3,5	Rotary
TK27	Property maintenance	0,04	Plate
PK03	Electrical room	0,1	-
PK04	Heat distribution room	0,2	-
PK05	Ventilated base floor	0,06	-
KK04	Lunch room, circulated air unit of skylight	0,14	-

Some of the air handling units have individually adjustable functions:

- TK05, Kitchen
  - Air flow rate can be intensified 0 to 5 hours with a time switch from the kitchen. Intensifying increases revs of the air handling unit
- TK07, Administrative wing
  - Air flow rate can be intensified 0 to 2 hours with a time switch from the lobby. Air flow rate is also intensified based on the measurements of CO<sub>2</sub> and temperature sensors. Intensifying opens intensifying dampers by space-specific to living room and recreation room
- TK08, Technical work class room
  - Air flow rate cannot be intensified
  - The operation of the air handling unit is affected by the exhaust air fans, which could be turned on for 0 to 2 hours with a time switch
  - When the exhaust air fan starts running, the air flow of the exhaust air fan is reduced from the TK08 air flow rate
- TK12, Day care lobby
  - Air flow can be intensified 0 to 4 hours with a time switch from the lobby. Air flow rate is also intensified based on the measurements of CO<sub>2</sub> and temperature sensors. Intensifying opens the intensifying dampers
- TK17, Multipurpose hall, stage
  - Air flow can be intensified 0 to 4 hours with a time switch from the multipurpose hall. Air flow rate is also intensified based on the measurements of CO<sub>2</sub> and temperature sensors. Intensifying increases revs of the air handling unit

- Sawdust extraction
  - The system includes a filter container where the sawdust is collected for removal
  - The system contains a heat recovery system, heat is recovered for a replacement air
  - The system also contains a pre-extinguishing system for a possible fire situation
  - The sawdust removal is not dependent on ventilation



**Figure 6.3.** Lunch room and stage. On front part of the stage is integrated supply air diffusers





**Figure 6.4.** Lunch room. Supply air is distributed with integrated supply air diffusers



**Figure 6.5.** Class room. Supply air is distributed with nozzle diffusers



Figure 6.6. Some of the walls are movable (the white wall in the picture)



Figure 6.7. Teachers' recreation room. Supply air is distributed with nozzle diffusers



Figure 6.8. Technical work class room. Supply air is distributed with nozzle diffusers

## 7 CONCLUSION

This thesis describes the planning and implementation methods of the ventilation systems and the achievement of the healthy and comfortable indoor climate in Finland. The thesis focused greatly on regulations and instructions issued in Finland aimed at guaranteeing comfortable and healthy conditions for users of buildings.

From the thesis can be discovered that the laws and regulations and companies and operators working in this field in Finland are focusing significantly on ventilation and human well-being of building and consider these matters important.

In order to achieve ventilation and achieve a good indoor climate, a comprehensive set of clear and useful literature can be found that allows the planning and construction of ventilation to be considered as good and high quality, as well as uniformity between different operators. In my opinion, the greatest benefits due to comprehensive regulations and instructions, are its achieved quality uniformity between different companies and operators which focus on ventilation and indoor climate. The uniformity of quality creates good credibility and trust for users of buildings so that everybody in the building can trust the air quality to be healthy and ventilation to be functioning.

The bachelor's thesis was written in a quite brief period compared to its extent. I'm still very pleased with achieved result and I think it's giving a comprehensive picture of the ventilation and the indoor climate in Finland. In my opinion the most important things which are influencing on the implementation of ventilation and the achievement of good indoor climate have been collected into this thesis.

## 8 BIBLIOGRAPHY

Cao, G & Heikkinen, J. 2013. Ilmanvaihdon tehokkuus eri ilmanvaihtojärjestelmissä. 2013. Helsinki: Aalto yliopisto.

[http://www.sisailmayhdistys.fi/wp-content/uploads/2013/06/13.3.13\\_-\\_guangyu\\_cao.pdf](http://www.sisailmayhdistys.fi/wp-content/uploads/2013/06/13.3.13_-_guangyu_cao.pdf)

CEN EN 15251. 2007. Indoor environmental input parameters for design and assessment of energy performance of buildings addressing indoor air quality, thermal environment, lightning and acoustic

Eskola, L. Jokisalo, J. Kalamees, T. Korpi, M. Kurnitski, J. Mikkilä, A. Palonen, J. Valovirta, I & Vinha, J. 2005. Puurunkoisten pientalojen kosteus- ja lämpötilaolosuhteet, ilmanvaihto ja ilmatiiviyys. Tampere: Tampereen teknillinen yliopisto, talonrakennustekniikan laboratorio.

Gregerson, J. 2010. The thermal comfort zone. Buildings magazine.

<https://www.buildings.com/article-details/articleid/9271/title/the-thermal-comfort-zone>

Harsia, P & Tuomola, T. 2008. Operatiivisen lämpötilan määrittely. Ensto.

<http://www2.amk.fi/Ensto/www.amk.fi/bin/get/dd/5hIWZhBDd.5glODoJI1>

Holopainen, E. Tarpeenmukainen ilmanvaihto ja automaatio päiväkotihankkeessa. 2016. Jyväskylä: Jyväskylän ammattikorkeakoulu.

Hänninen, O. 2014. Sisäilmastoseminaari: Vaikutukset sisäilman terveysriskeihin. Helsinki: Terveyden ja hyvinvoinnin laitos

Rakentamismääräyskokoelma D2. 2008. Rakennusten sisäilmasto ja ilmanvaihto. Helsinki: Ympäristöministeriö.

Rakentamismääräyskokoelma. Ympäristöministeriön asetus uuden rakennuksen sisäilmastosta ja ilmanvaihdosta. 2017. Helsinki: Ympäristöministeriö.

Rakentamismääräyskokoelma. Ilmanvaihdon mitoituksen perusteet -hanke, loppuraportti. 2018. Helsinki: Ympäristöministeriö.

Rakentamismääräyskokoelma. Ympäristöministeriön asetus rakennuksen ääniympäristöstä. 2017. Helsinki: Ympäristöministeriö.

RT 07-10946. RT-ohjekortti. Sisäilmastoluokitus 2008. 2009.

Sandberg, E. 2016. Sisäilmasto ja ilmastointijärjestelmät: Ilmastointitekniikka osa 1. Talotekniikka-Julkaisut Oy.

Sandberg, E. 2014. Ilmastointilaitoksen mitoitus: Ilmastointitekniikka osa 2. Talotekniikka-Julkaisut Oy.

Seppänen, O. & Seppänen, M. 2004. Rakennusten sisäilmasto ja LVI-tekniikka. Espoo: SIY Sisäilmatieto Oy.

Seppänen, O & Fisk, W. 2005. Some quantitative relations between indoor environmental quality and work performance or health.

SFS 5907. 2004. Rakennusten akustinen luokitus. Suomen Standardisoimisliitto SFS ry.

SFS 50-1. 2015. Rakennusten ilmanvaihto. Osa 1: Ilmastointikanavat. Suomen Standardoimisliitto SFS ry.

SFS-EN 12236. 2002. Rakennusten ilmanvaihto. Kanaviston ripustimet ja kannattimet. Kestävyysvaatimukset. Suomen Standardoimisliitto SFS ry.

Sugarman, S. 2007. HVAC fundamentals 2nd edition. Lilburn: The Fairmont Press, Inc.

Tampereen kaupunki. 2017. Tesoman koulu ja päiväkotii, uudisrakennus. LVIA käyttäjä koulutus. Tampere: Insinööritoimisto Erkki Leskinen Oy.

Vallinen, J. 2012. Ilmanvaihtosuunnittelun perusteita. Espoo: Metropolia ammattikorkeakoulu.

Viitanen, K. 2003. Finnish-English dictionary of real estate. Espoo: Kiinteistöopin ja talousoikeuden julkaisuja.