



PRACTICAL GUIDE ON
BEST RESOURCE EFFICIENT
TECHNOLOGIES IN SMALL PORTS

TECHNOLOGY, PURCHASING & INSTALLATION

PRACTICAL GUIDE ON
BEST RESOURCE EFFICIENT
TECHNOLOGIES IN SMALL PORTS
TECHNOLOGY, PURCHASING & INSTALLATION

Satakunta University of Applied Sciences
2019
Pori

Satakunnan ammattikorkeakoulu (SAMK) | Satakunta University of Applied Sciences
Series B, Reports 4/2019
ISSN 2323-8356 | ISBN 978-951-633-272-0 (pdf)

© Satakunta University of Applied Sciences and the authors

Publisher:

Satakunnan ammattikorkeakoulu
PL 1001 | FI-28101 PORI
www.samk.fi

Graphic design: Kristiina Kortelainen

Layout: Hanna Rissanen

Cover photo: Kristiina Kortelainen

Project: PortMate CB393: Safely connected and sustainable small ports in Central Baltic region

Authors from Central Baltic PortMate project lead partner SAMK:

Heikkinen, T. Salahub J. & Keinänen-Toivola, M.M.

How to cite to this publication:

Heikkinen, T. – Salahub, J. – Keinänen-Toivola, M.M. 2018. Practical Guide on Best Resource Efficient Technologies in Small Ports – Technology, Purchasing and Installation. Central Baltic PortMate. Series B, Reports 4/2019. Satakunta University of Applied Sciences. Pori.

CONTENTS

1 INTRODUCTION	5
2 DEFINITIONS	6
3 LED LIGHTING SOLUTIONS	9
3.1 LED lighting technology description	9
3.2 Light characteristics.....	10
3.3 Installation – general issues	12
4 PV SOLAR ENERGY SOLUTIONS.....	16
4.1 PV technology description	17
4.2 On-Grid PV system architecture	17
4.3 Off-Grid PV system architecture.....	19
4.4 Installation – general issues	21
4.5 Installation – port specific issues.....	23
4.6 PV for powering LED lighting	24
5 SEPTIC WASTE PUMP-OUT STATION	25
6 PURCHASING PROCESS.....	30
7 CONCLUSIONS	34
REFERENCES.....	35



1 INTRODUCTION

In our everyday lives, we are already paying attention to resource efficiency issues and making some actions like recycling, changing our diet and using more energy efficient solutions. This is easy in our homes when the supporting infrastructure exists. What about our free time? How do we behave when we are boating, for example? Being green and conscious can even feel a bit of burden when traveling and having time off. Overlooking waste sorting is easy if e.g. the guest port does not offer recycling service but only one mixed waste bin. This is why more attention needs to be paid to resource efficiency solutions also in holiday resorts and other places where people spend their free time, not to forget in small ports used in recreational boating.

Resource efficiency in practice means using new, mostly technological solutions to use less resources like water and energy and to produce less waste. Creating more with less while minimizing the impact on the environment (Dersten, et al. 2018, 9). Resource efficient solutions are often technologies people use in their daily lives, e.g. LED lighting: the same or better light than other options but with less energy.

The purpose of this report is to give practical guidance on resource efficient technologies which could be used in small ports and also to give guidance for purchasing and installing these technologies – to make the infrastructure used at homes available in small ports, too. The aim of the report is not to be a comprehensive study of every possible resource efficient technology but to concentrate on technologies that have been installed in the Central Baltic PortMate project pilot ports to enhance resource efficiency.



2 DEFINITIONS

Charge controller

Device used in Off-grid PV solution with purpose to control the charging of the battery or battery bank. Prevent the batteries from over charging and over discharging. With smaller PV systems, charge controllers can act also as electricity distribution controller.

Colour Rendering Index (R_a)

The colour rendering index is a measure of how well the light source reproduces eight specific colours in comparison to an artificial reference light source. The maximum R_a value of 100 is achieved when the eight colours are rendered identically (for the test and reference light sources), with decreasing R_a values for increasing colour differences between the test light source and the artificial reference light source. (Wikipedia 2019)

DHW

Domestic hot water.

IP Code rating

“IP Code (or “Ingress Protection”) ratings are defined in European Standard EN 60529. They are used to define the degree of protection provided by enclosures for electrical equipment. Enclosures protect against intrusion from foreign bodies (tools, dirt, etc.) and moisture.” (Website of The Enclosure Company 2019.)

LED

Light Emitting Diode is a semiconductor device that emits visible light of a certain color, and is fundamentally

different from conventional light sources such as incandescent, fluorescent, and gas-discharge lamps: uses no gas or filament, has no glass bulb, and no failure-prone moving parts. (Website of Lighting design lab 2019.)

MPPT

Maximum power point tracking. Device located in solar inverter with purpose to maximize the power drawn from the PV panels in varying insolation conditions.

MSD

Marine Sanitation Device. Sewage system of the boat with toilet seat, holding tank, piping, valves etc. Piece of machinery or a mechanical system that is dedicated to treat, process, and/or store raw, untreated sewage that can accumulate on-board water vessels (Wikipedia 2019).

Nominal peak power

Or nominal power is the name plate capacity of photovoltaic (PV) panel i.e. the power output of a panel in standard test conditions (STC).

Off-Grid PV

PV system installed to a building with no existing power grid connection. Independent power system, which thus always includes batteries for storing the excess energy of the daylight time for dark hours usage. Includes often 12VDC, 24VDC or 48VDC devices for electricity consumption such as LED lighting. Used a lot in summer cabins typically to cover the very basic electricity needs (e.g. lighting, mobile device charging, and fridge). System sizes are typically smaller than On-Grid PV systems starting from c. 100Wp.

On-Grid PV

PV system installed to a building with connection to national power grid and the PV system is also grid connected. Possible excess PV energy is transferred/sold to the grid. Usually system does not include batteries and PV system is only auxiliary power source. Residential size PV systems are typically between 2-5kWp.

PV	Photovoltaic. Semiconductor material based technology where the sun's radiation is converted directly to electricity (DC).
Small port	Definition of small port in this document includes guest ports, natural ports and other public ports and harbours serving local people and visitors.
Solar inverter	Electric device used with On-Grid PV solutions with purpose to convert the DC current produced by the PV panels to AC current suitable for regular home appliances. Solar inverter is also responsible for adequate quality of electricity suitable for local and public electric grid (when excess energy) and switching off the PV production in case of blackout in the public grid.
Solar thermal	In domestic scale, solar thermal is a technology in which the heat energy of the sun is captured with solar collectors and used for heating. Heat transfer liquid is heated in the solar collectors and the heat is transferred to storage tank via piping and heat exchanger for further usage in heating or in DHW production.
STC	Standard test conditions used in PV panel testing and in panel nameplates. STC conditions are 1000W/m ² of light intensity, 25°C of cell temperature and 1.5 of air mass (AM) coefficient.



3 LED LIGHTING SOLUTIONS

Even though in Northern waters the days are long during the high season of boating, artificial lighting is still needed indoors and during dark hours in the autumn. During the past few years, the lighting products have been changing rapidly. Especially LED lighting products have been developing quickly and LEDs are already today the most used lighting technology.

Energy efficient lighting pays back with lower energy consumption and longer lifetime. LED lights are rapidly replacing conventional lighting techniques and there are already a vast variety of LED lighting solutions available. You can either replace regular incandescent and fluorescent light bulbs with LED equivalent or get new LED light fixtures at a reasonable price. The lifetime of LEDs is even longer than fluorescent lights and even 50-times longer than a traditional incandescent light bulb. (Website of Motiva 2018.)

3.1 LED lighting technology description

LED lights often consist of many separate light emitting diodes, LEDs. These form together a lighting fixture of the whole lighting device or replaceable bulb to be installed to an existing lamp. The current big trend in LED lighting is that LEDs (“bulbs”) cannot be replaced when they are broken because the LEDs are a fixed part of the LED light fixture (Picture 1a). Manufacturers do promise a long lifetime for these products but it is good to remember that when this type of light goes out or a substantial part of the LEDs of the light fixture goes out, the whole device must be changed to a new one. In this case, an electrician is also needed. The other option is to use traditional replaceable lights with LED bulbs. LED bulbs are available for commonly used socket types like E27 and GU10, shown in picture 1b.

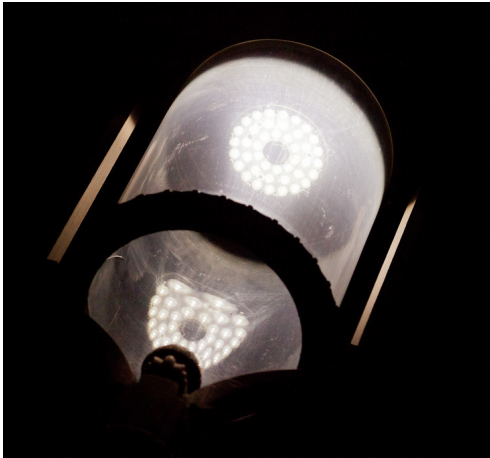

Picture 1a. Outdoor light with retrofitted LED fixture (U.S. Department of Energy).



Picture 1b. Replaceable LED light bulbs with traditional sockets GU10 and E27 (Samsung).

There exists an EU-wide EcoDesign directive (2009/125/EC) that applies to energy-related products and thus also to lighting products. The directive is currently under renewal process and there has been discussion if there would be a requirement about the possibility to change the light source (bulb) of the lighting product. However the latest draft (Dec 2018) of the directive does not set requirements for this. Renewed directive should take effect in September 2021. (Website of Suomen valoteknillinen seura 2018.)

3.2 Light characteristics

Buying or changing of a traditional light bulb was easy. People generally knew about how much a 40W or 60W incandescent bulb would give light. Also the colour of the light was always the same, “warm white”. With LEDs this has changed. There are still Watts but also Lumens, Kelvins and Colour rendering indexes that are used. Table 1 presents the equivalence between traditional incandescent bulb power rating and LED/CFL bulb light amount.

Table 1. Incandescent bulb and LED/CFL bulb equivalence (Website of lamputieto.fi).

Incandescent bulb	LED / CFL bulb
25 Watts	250 lm
40 Watts	470 lm
60 Watts	800 lm
75 Watts	1050 lm

Next, some of the basic light characteristics and type plate information will be described briefly. This is the information you can typically find on datasheets and lamp packagings.

Power (Watts [W])

This is the amount of electric power light device or bulb consumes when it is on. The used unit is Watt (Symbol W). Relation to consumed energy it is such that if e.g. 11W LED light is on for an hour it has consumed 11Wh of energy. Note that this does not tell about the amount of light the bulb gives.

Luminous flux (Lumen [lm])

Luminous flux is the total amount of light radiated by a light source (lamp) in all directions. (Website of Lampputieto.fi 2019.)

Luminous efficacy (Lumen/Watt [lm/W])

Luminous efficacy is the relation between the previous two. It tells how many Lumens of light is radiated per used Watts of power i.e. it tells how energy-efficiently the light is produced. This is the easiest way to compare the energy-efficiency of different lamps. If it is not given, it is also easy to calculate by just dividing Lumens with Watts, both given in nameplate.

Lamp lifetime (Hour [hrs])

This is the average operation lifetime (in hours) a lamp should last. The number is based on the IEC-standard and tells the rounded hour reading after which 50% of the tested lamps were still on. Hour reading is based on typical household indoor use. (Website of Lampputieto.fi 2019.)

Colour temperature (Kelvin [K])

Colour temperature, measured in Kelvin (K), represents the visual appearance of a light bulb. The higher the Kelvin rating given to the light bulb, the cooler its appearance will be.

- 6500K – Natural Daylight (how the sun appears at midday)
- 5000K – Daylight
- 4000K – Cool White
- 3500K – White
- 3000K – Warm White (Halogen bulbs normally have a colour temperature of 3000K)
- 2800K – Very Warm White (most incandescent bulbs have colour temperature 2700K)

(Website of General Lamps 2019.)

Colour rendering index (CRI) [R_a]

The colour-rendering index defines the ability of a light source to identify colours, and is measured on a scale of 1 - 100. On this scale, a rendering of 1 is monochromatic light, and a rendering of 100 is natural sunlight, so you can think of the scale as a measure of the quality of light produced by the source. (Website of General Lamps 2019.) The recommendation for household use is that CRI should be no less than R_a 80 (Website of Lampputieto.fi 2019).

Advantages of LED

- small energy consumption
- long lifetime, even 25 years
- low overall costs
- lots of choices in colour tones
- lights up instantly
- dimmable
- works well with lighting automation solution

(Website of Lampputieto.fi 2019.)

3.3 Installation – general issues

Quality of light

Lighting should be adequate and suitable for the planned location and activity. In addition to lighting designers, there are guides and programmes one can use for designing the indoor and outdoor lighting (eg. DIALux evo). In the outdoors, one thing to consider is the light pollution and how to avoid it. This is important especially in Off-Grid islands or ports with no prior lighting or electricity. The darkness may be an important part of the port's atmosphere and one should be careful not to spoil it with too bright or visible lighting solutions. Good advice is to build the lighting so that only the needed area like a pathway is illuminated. For this purpose, LED lighting is a good option. See pictures 2a, 2b, 2c and 2d showing recent PortMate installations from small ports of Storjungfrun (island) in Söderhamn, Gävle city port and Syväraumanlahti in Rauma.



Picture 2a. Pathway lighting in Storjungfrun, Söderhamn. © Göran Hånell.



Picture 2b. Dock LED lighting in Syväraumanlahti, Rauma. © Markus Savolainen

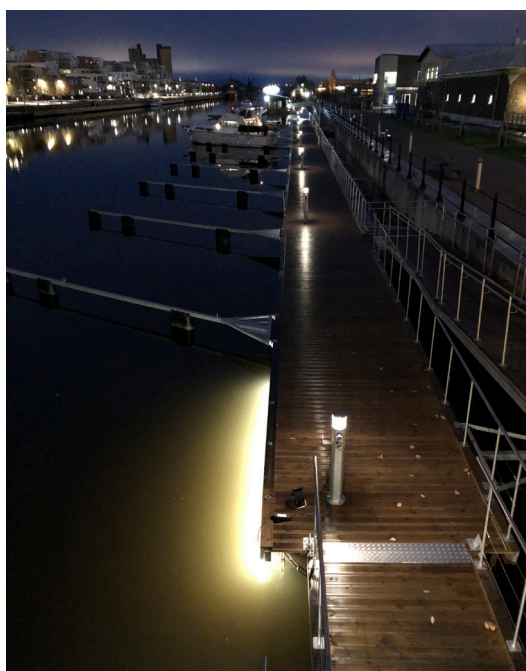

Picture 2c. Dock LED lighting in Gävle city port. The under dock lighting is yet a test version. © Marita Olsson Narving.

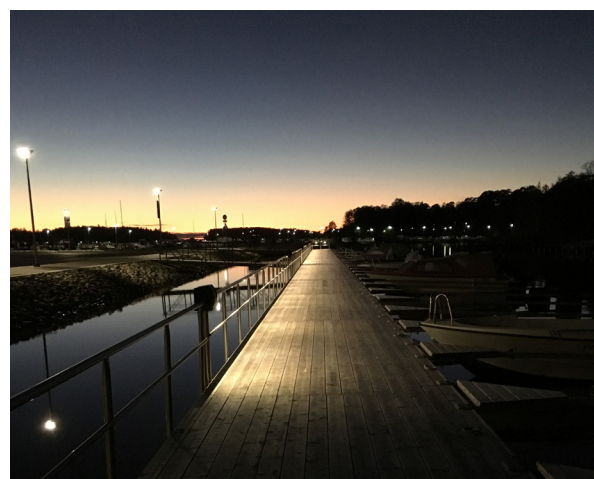

Picture 2d. Dock LED lighting in Syväraumanlahti, Rauma. © Markus Savolainen.



IP Code rating

When installing outdoors, light should be suitable for outdoor use. In other words, it should withstand the varying weather conditions. One good aid when selecting a suitable light is the IP Code rating for electrical equipment enclosures. This rating is defined in standard EN 60529 and the aim is to give:

- 1) protection of persons against access to hazardous parts inside the enclosure;
- 2) protection of the equipment inside the enclosure against ingress of solid foreign objects;
- 3) protection of the equipment inside the enclosure against harmful effects due to the ingress of water. (SFS- EN 60529 2000, 17).

See figure 1 for details of the IP Code interpretation.

Ingress Protection (IP) Ratings

Connectors may be susceptible to ingress of foreign materials such as moisture or dust, particularly in the unmated connection. Protection from this ingress is provided for connectors by their housing and the seal between the plug, jack, and cable or between a jack and a panel. The IP standard rating system defines the degree of protection provided. The standard IEC 60529 has specified the degree of protection and divided it into several levels, defined by the IP number, which has the letters IP followed by two digits. The first digit defines the protection against the ingress of dust particles, the second digit defines the protection against the ingress of water. The tables below show IP ratings for electrical connectors:

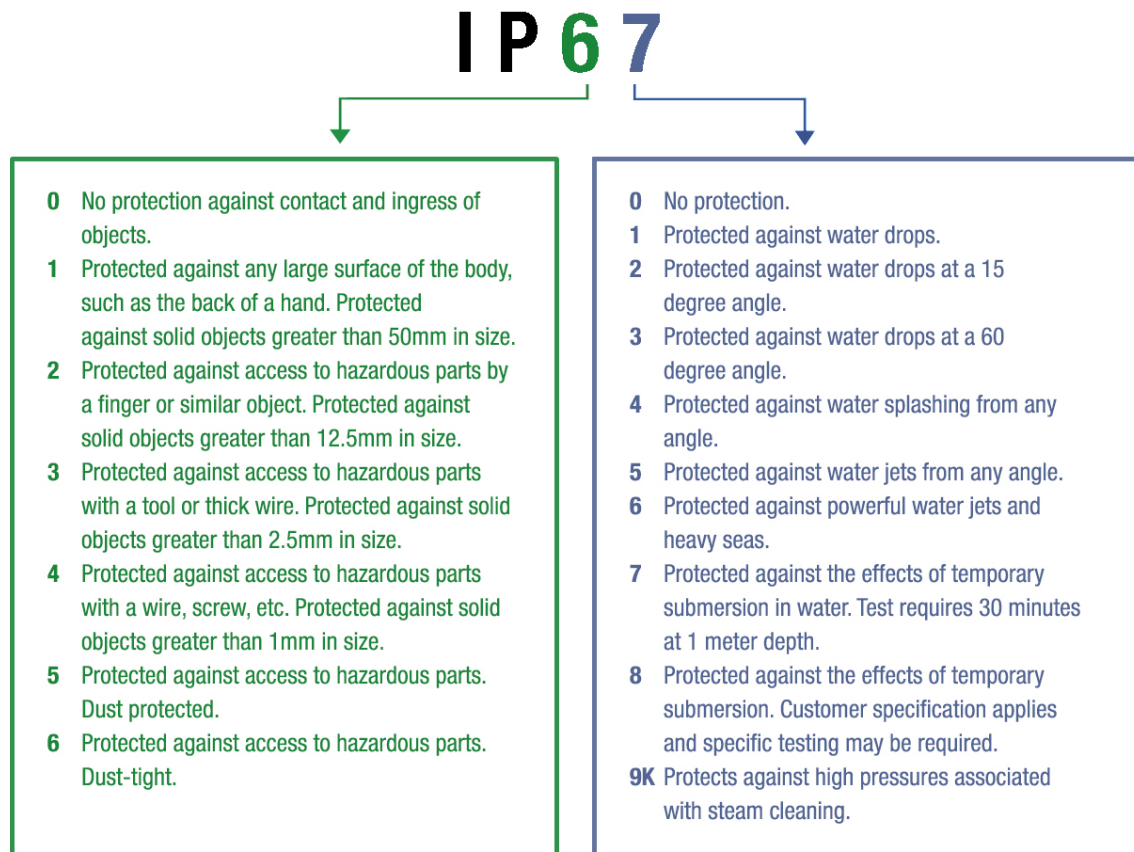

Figure 1. IP Code rating (SFS-EN 60529 2000, 23-25). © Hanna Rissanen

Outdoor lights should naturally be weatherproof i.e. IPx3. Commonly IP44 rated lights are used. One should always make sure that the related LED-driver/transformer or timer is also suitable for outdoor use. With a higher IP rating (both digits bigger) the product is even better protected from dust and water, but with smaller ratings the risk of damaging the device (or people using them) increases. (Aaltonen 2018.) Additionally as all electric devices, light products should always have a CE-marking, type and model label.

Electrical safety (TUKES)

Actual electrical work should be left for registered professionals (Picture 3). However, you may perform certain minor electrical work yourself when you are



certain you can do them safely and properly. Always make sure electrical installations are de-energised before working on them. Additionally, make sure no one else will be able to switch on the power to the circuit you are working on. (Website of TUKES 2019.)

Picture 3. Installation of dock LED lighting ongoing in Syväraumanlahti Rauma.
© Markus Savolainen



Tasks every electricity user is allowed to perform:

- replacing a fuse in a switchboard;
- making an automatic fuse or residual-current device operational again;
- testing the functioning of a residual-current device using a test button;
- changing a dimmer fuse;
- replacing a light bulb and starter;
- checking the circuit is de-energized by using an approved voltage tester when carrying out tasks anyone is allowed to perform.

Repair and installation tasks everyone is allowed to perform:

- repairing and constructing single-phase extension cords;
- replacing damaged single-phase connection cords and plugs of appliances;
- connecting household light fittings using a connection block;
- in a fixed installation replacing the connection block with a new-system ceiling case and replacing a damaged ceiling case (not installation or replacement of the wiring);
- assembling electrical appliances as a hobby, such as using electronic construction kits and repairing such appliances.

Other work everyone is allowed to perform:

- installing a household aerial;
- repairing mechanical parts of electrical appliances, such as replacing a washing machine hose, provided that the appliance's contact and water protection remain unaffected;
- uninstalling electrical installations that have been reliably and fully de-energized. (Website of TUKES 2019.)

4 PV SOLAR ENERGY SOLUTIONS

Utilizing solar energy can be a feasible solution for providing electricity or domestic hot water (DHW) for the small port's usage. Solar energy is renewable, sustainable and abundantly available during the boating season also in northern latitudes. The figures 2a and 2b illustrates that the archipelago and the coastal areas are the best places for solar energy utilization. For DHW production, solar thermal solutions can be a good option, but when electricity is needed photovoltaic (PV) i.e. solar electricity is the only practical choice. In this document, the focus is on solar electricity solutions.

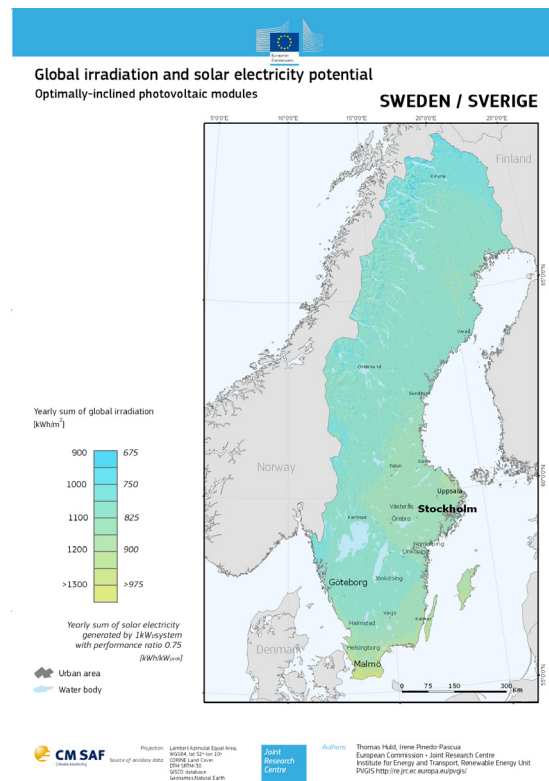
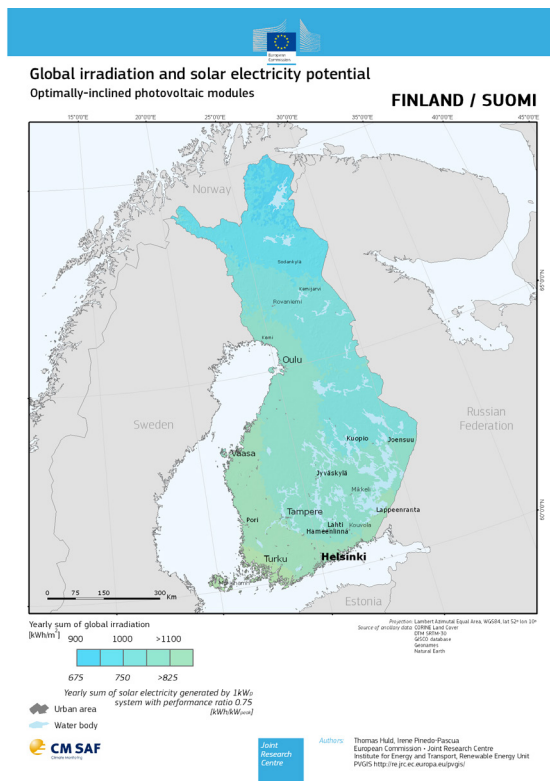

Figures 2a, 2b. Solar electricity potential of Finland and Sweden (PVGIS 2019).

PV can supplement existing electric supply and compensate part of the potentially expensive grid electricity (On-Grid PV). In case there is no existing power grid available, PV can be the cheapest way to provide electricity to a port. Off-Grid PV solutions are a good option especially if the port is on an island with no existing power supply or if an expensive power-distribution network would need to be built for the port solely.

4.1 PV technology description

PV panel

The PV panel is the basic component of any PV energy system. It converts the sun's radiation directly to electric current without any moving parts. The most commonly used crystalline silicon based PV panels consist of c. 15x15cm PV cells connected in series. Each cell gives 0.5V to 0.6V output voltage and the output voltage of a single panel thus depends on the amount of serially connected PV cells used for assembling it. Also the nominal peak power (Wp) of the PV panel increases with the number of PV cells.

PV panel types used in On-Grid solutions are typically bigger (270-300Wp) compared to the ones used in Off-grid PV solutions (50-100Wp) meaning that they have more cells per panel and thus higher voltage output and power rating. All PV panels produce DC current, which means that a solar inverter or regular power inverter is needed if converting current to 230VAC suitable for regular home appliances. In Off-Grid solutions, also DC devices are commonly used at least as part of the solution e.g. for LED lighting purposes.

4.2 On-Grid PV system architecture

PV energy systems are easily scalable. The needed amount of PV panels depends on the energy production requirements set for the system. In addition, the geographical location of the PV system is important. Typical domestic scale On-grid PV system size in Finland is 3-5kWp which equals to 12-20 pieces of 270Wp panels. Usually PV array is installed on the roof and requires in this case 20-34m² of roof space. Picture 4 shows one example of 20 panel installation from Sottunga small port in Åland. In this case, the PV system has been installed on the roof of a restaurant building right next to the guest dock of the small port.

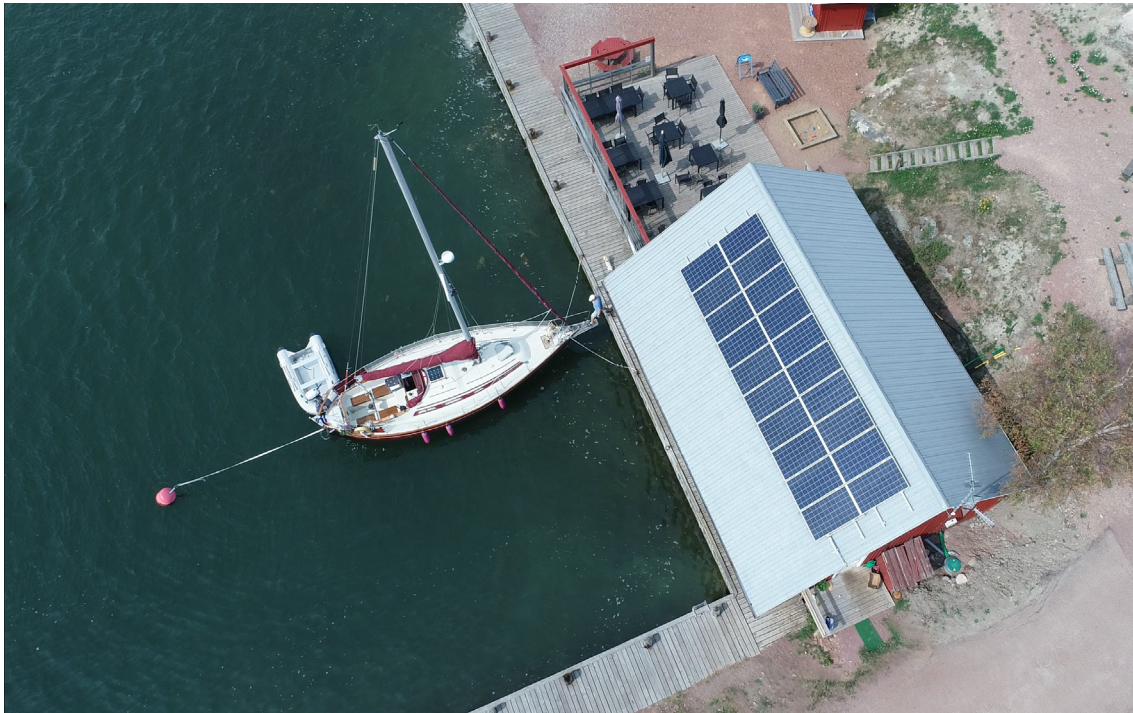

Picture 4. Installed On-Grid PV system in Sottunga small port.
© Kristiina Kortelainen



The On-Grid PV system consists of the following basic components: PV panels with suitable mounting rack, solar inverter, safety switch and suitable DC and AC wiring, connectors and different kind of fasteners for wires. The power distribution board and electricity meter act as a connection point to an existing house network and power-distribution network. See figure 3 for an architectural illustration of On-Grid PV system and its basic components.

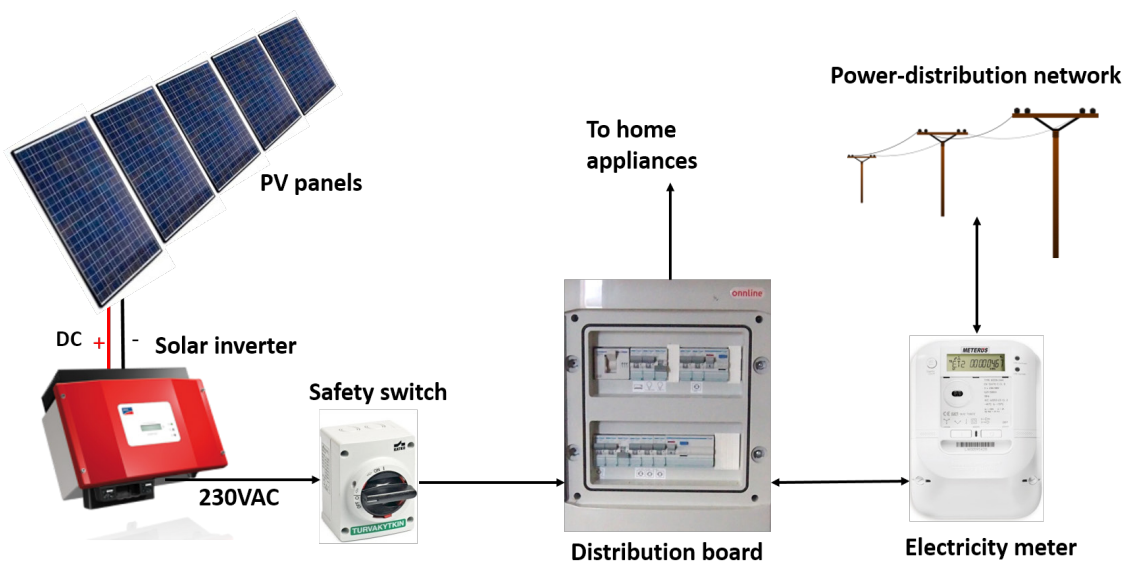

Figure 3. On-Grid PV system architecture. © Petri Lähde

4.3 Off-Grid PV system architecture

With Off-grid, the basic reason for smaller panel size used is the lower needed DC voltage output. This is because it is more economical to build a local DC house network and use DC powered devices without power inversions. In addition, a charge controller capable of handling higher input voltages from panel is more expensive. There is a variety of DC devices available. Especially for 12VDC, the entire device selection available for cars or caravans are suitable as such for the 12VDC Off-Grid PV powered house network. In DC-AC power inversions some energy is always lost thus it is more energy efficient to avoid unnecessary power inversions. Pictures 5a, 5b and c shows an example Off-Grid PV installation from PortMate pilot port in island of Storjungfrun in Söderhamn.



Picture 5a. Off-Grid PV installation in Fyrhamn in island of Storjungfrun in Söderhamn. © Alberto Lanzanova.





Pictures 5b, 5c. Off-Grid PV installation in Fyrhamn in island of Storjungfrun in Söderhamn.
 © Alberto Lanzasova (5b), Göran Hånell (5c).

In Storjungfrun shed installation, one 50Wp panel and 260Ah battery combination is producing energy for the shed's own lamp and pathway lighting shown in picture 2a. The DC power from the charge controller (Sunwind PeakPower 2.0) is used as 12VDC for powering the shed lamp. DC to AC power inverter (Sunwind 300W) is used to convert the 12VDC of the batteries to 230VAC for the pathway light poles seen picture 2a. In pictures 5b and 5c you can see also temperature sensor of the charge controller, couple of wire fuses and a switch box containing time and light control device and fuses. At the time of taking picture 5c the battery is still missing a proper cover box.

The Off-Grid PV system consists of the following basic components: PV panels with suitable mounting rack, charge controller, batteries and suitable DC wiring, connectors and fuses. Optionally, if there is a need for using the regular On-Grid house appliances, also a DC to AC inverter and proper AC wall sockets and electric safety devices are required like in picture 5b. See figure 4 for architectural illustration of an Off-Grid PV system.

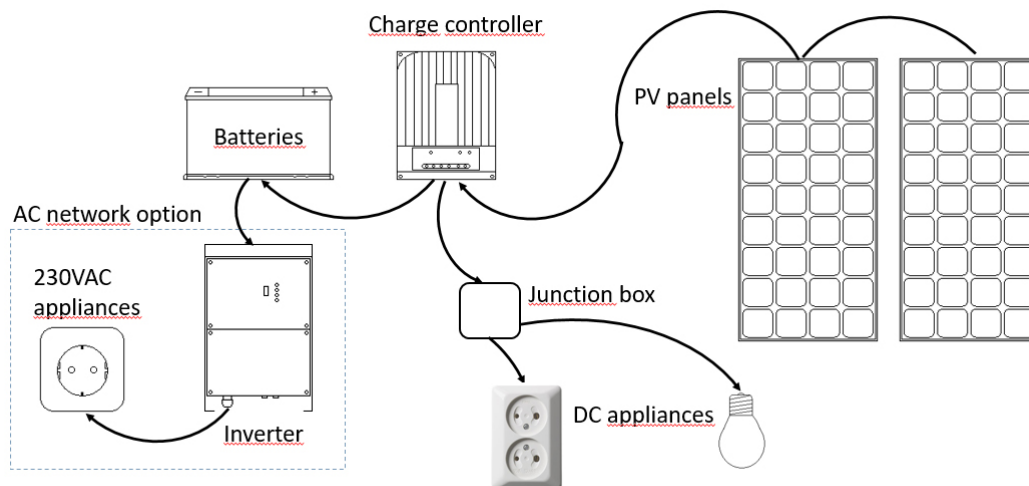

Figure 4. Basic Off-Grid PV system architecture. © Petri Lähde

4.4 Installation – general issues

Shading

PV panels should be installed in a sunny place with minimum shading during the day. Commonly rooftops are used, but also wall or ground installations are possible. Because the PV cells of a PV panel and PV array of panels are serial-connected, even partial shading of a single cell of a single panel can dramatically drop the production power of the whole array. This resembles the situation where you unscrew one lamp of Christmas tree lights and all lights of the light chain go out. Picture 6 presents one example of a poor PV panel installation. In this case, the overhang of the roof is shading top cell rows of the panel dropping the current output of the system to zero.



Picture has been taken at noon on 12th of June. In practice, the overhang will shade the panel several hours every day around noon in June and July. This emphasises the importance of proper planning and design before the installation. The path of the sun during summer days should have been studied more carefully before the installation. An easy way to fix the problem in this particular case would be to lower the panel with about 30cm.

Picture 6. PV panel installation example where upper part of panel is shaded during noon in June. © Kristiina Kortelainen

Panel orientation

When there are more panels in the array, it is important that panels of the same series point to the same direction i.e. are installed e.g. on the same roof face parallel to the roof. This is important because panels connected to same series and thus to the same maximum power point tracking (MPPT) device, should have same insolation conditions. Otherwise, the power of the whole array goes according to the panel with poorest sun conditions at the time and the installation is not optimal.

The optimal panel direction for maximum annual production is always south and the panel inclination in southern Finland is about 40 degrees. However, the effect of panel orientation is smaller than one easily assumes and all the directions between southeast and southwest are good and the inclination can be smaller especially when the biggest need for electricity is during summer time. Table 2 shows an example on how different panel/array orientation affects the production in Pori, Finland. High percentage readings in the example supports the previous statement about the moderate effect that the panel orientation has on the production. More localized production estimations can be easily drawn using the same tool used in making the example table. The tool is called Photovoltaic Geographical Information System (PVGIS) and it has been developed by European Commission Joint Research Centre. It can be freely used with web browser at: http://re.jrc.ec.europa.eu/pvg_tools/en/tools.html#PVP.

Table 2. The effect of the panel direction and inclination to production in Pori, Finland.

Point of compass	Inclination														
	10°	15°	18°	20°	25°	30°	35°	40°	45°	50°	55°	60°	65°	70°	90°
east	80 %	80 %	80 %	80 %	79 %	79 %	78 %	77 %	76 %	75 %	73 %	71 %	69 %	66 %	54 %
south-east	86 %	88 %	90 %	90 %	92 %	93 %	94 %	94 %	94 %	93 %	92 %	90 %	88 %	86 %	71 %
south	88 %	91 %	93 %	94 %	96 %	98 %	99 %	100 %	100 %	100 %	99 %	97 %	95 %	92 %	76 %
south-west	86 %	88 %	89 %	90 %	92 %	93 %	94 %	94 %	94 %	93 %	92 %	90 %	88 %	86 %	71 %
west	80 %	80 %	79 %	79 %	79 %	78 %	78 %	77 %	76 %	74 %	73 %	71 %	68 %	66 %	53 %

Source: PVGIS <http://re.jrc.ec.europa.eu/pvgis/apps4/pvest.php>

4.5 Installation – port specific issues

Weather and seawater

Small ports are often located in islands and naturally near open waters where weather conditions can be generally more violent than inland. On the other hand, the best direction for the panels can be towards the sea where there are no shading obstacles. Special attention must be paid both to the mounting of the PV system components, and to the specifications of the used components to be located outside.

When installing on the roof, the panels are wise to be mounted parallel with the roof to avoid potential extra wind resistance and the risk of subsequent damage. Also, this is usually the easiest and the cheapest way for mounting since the most common rack systems are made for this kind of installation. Installed PV panels themselves should be suitable for marine conditions i.e. tolerate salty water. The advantage of the windy location is the cooling effect wind has on panels. A known fact is that the panel temperature has an effect on the panel efficiency by decreasing the power output c. 0.5% per each rising degree Celsius. The same applies to the other direction. E.g. when a PV system output is 1000W while the cell temperature is 35°C it would be 1050W with cell temperature of 25°C assuming the insolation stays the same. Since the PV panels have dark surfaces they usually are notably warmer than the ambient temperature.



Picture 7. PV system installation. Panels attached parallel to roof and wiring goes from roof to solar inverter via shortest route to protecting custom-made inverter casing on the wall.
© Kristiina Kortelainen



With solar inverters, there are models that can be installed both indoors and outdoors and models that are for indoors only. In the marine weather conditions, it is especially important to use the outdoors model when installing outdoors. With high winds there can be salty water flying horizontally, which the solar inverter must tolerate. One option is to use additional coverage cabin to protect the solar inverter from weather and dust. However, in this case one has to make sure the inverter still has good ventilation. Remember that the highest cooling need and the highest ambient cooling load of the inverter often coincide during the hot sunny summer days. In other words, avoid installing solar inverter in a sunny place. It will likely look and function better for a longer time in a more shaded place. In the installation presented in picture 7, the custom-made coverage cabin and the solar inverter inside it are under long eaves protecting them from the sun for the hottest hours of the day.

Logistics

Compared to coastal and inland locations the installation can cost significantly more when done on an island with limited logistical options. How can the components be transported in place? How about the hoisting equipment if needed or maybe extra people to compensate? Are specific tools or aggregators needed in place for powering the tools? How long does it take the installers to travel to the site? What if some essential tool is left at the office and needs to be retrieved. These all are issues that should be agreed beforehand and usually means extra costs for the customer. Good planning is essential and should be emphasized. Additionally, the variety of potential service providers that operate in the archipelago may be limited.

4.6 PV for powering LED lighting

Since the PV system produces DC power that LEDs can consume they can be used nicely together without needless DC-AC conversions. This is especially the case with Off-Grid PV systems where the whole electrical system can operate with DC electricity only. DC LED bulbs are simpler not having the AC-DC converter as an extra part that can break. Moreover, less energy is wasted for conversion.

However, with low voltage DC systems the operating voltage is lower (12V, 24V or 48V) compared to AC systems (230V). This affects transfer losses: the lower the operating voltage the higher the losses in the transfer i.e. in wiring between the electrical gadgets. These losses can be compensated with bigger wires (larger cross-sectional area) but it will cost more. In other words, the distances firstly between PV panels and batteries and secondly between batteries and devices should be optimized to minimum being rather max 15-20m than more (12V systems). One benefit with the low voltage systems (max 50VAC and max 120VDC) is that installation are legality and safety perspective possible to perform without official permits as long as the installer is properly familiarized to the tasks (Website of TUKES 2019).



5 SEPTIC WASTE PUMP-OUT STATION

When people are spending longer times boating there is a natural need for handling the septic and other wastewaters accumulated during the trip. All boats having their own water toilets need to have a holding tank for collecting the septic waste. In Finland, the draining of septic wastewaters from recreational boats into the watersheds has been illegal since 2005 (Act on draining septic waste to waters 435/2000, section 18). In Sweden, it has been prohibited since 2015 (Svenska båtunionen 2015).

The resource efficient solution for the handling of septic waste is to have a septic waste collection network dense enough for proper emptying of the septic tanks of the boats. In practice, this collection is implemented with using septic waste pump-out stations. Usually the pump-out stations are located within small ports or nearby. Pump-out station is an important and valued service in a small port and it increases the port's attractiveness among boaters (Website of Pidä Saaristo Siistinä 2019). Pump-out stations are marked with symbols presented in the pictures 8a and 8b.

In Finland, small port or marina with 50 boat berths or more, serving mainly recreational boaters, has an obligation to receive waste including septic wastewaters if the marina is collecting fee for the berths. Same obligation applies if a marina can offer winter docking places for 50 boats or more. The obligation can be shared with another small port nearby when agreed to do so. (Act on Environmental Protection in Maritime Transport 1672/2009, chapter 9.)

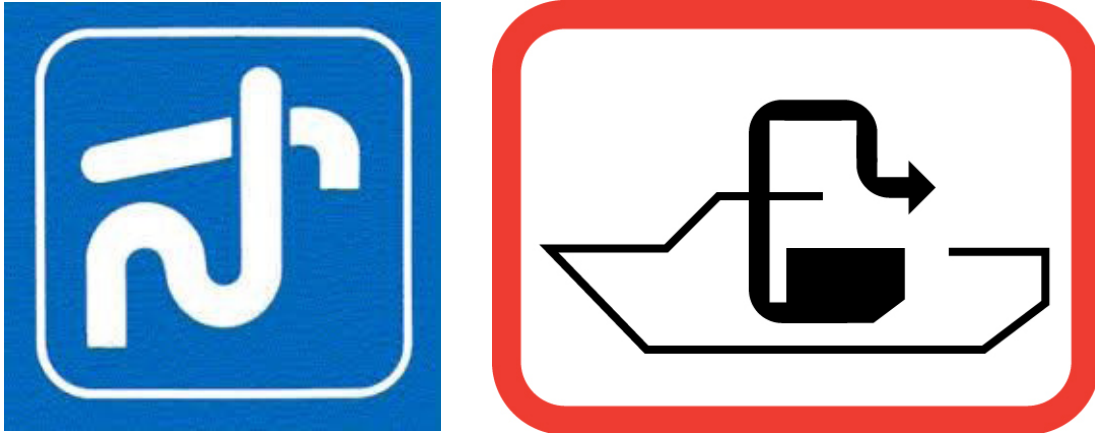

Pictures 8a, 8b. Symbols used for marking the septic waste pump-out stations. First one is used at least in Finland and Sweden and the second one more commonly in the USA.

Planning

There are many types of pump-out stations available on the market. Every port is different so one solution does not work for all. Therefore, each case should be examined individually, and the pump-out that will work best in any particular situation should be selected. Costs for equipment and installation can vary greatly, depending on the need for special onshore holding tanks to hold septic waste, the cost of connection to a sewer system, and other factors. (Connecticut Department of Energy & Environmental Protection 2000, 10.)

Equally important with deciding which kind of pump-out technology suites the port best is to plan through the whole chain of the sewage waste handling process. After the septic waste is collected from the boats, it needs to be treated properly. Is there an existing connection to a municipal wastewater treatment facility from the port or can the connection be built with reasonable costs? Are there other stakeholders: businesses, summer cabin owners etc. who could be interested in having a sewage connection that you could co-operate? Who is responsible for the needed maintenance work and on whose expense will the maintenance be done? What if the system includes a bigger tank onshore or a floating one offshore, how often does it need to be emptied and how is it arranged etc.?

Septic Pump-out Station Technologies

There are at least three types of pump-out stations that can be classified: Fixed onshore stations, floating barge type stations and portable wheelbarrow to trailer size wheeled pump-out stations. The needs and possible installation location should be carefully studied before the investment decision. (Website of Pidä Saaristo Siistinä 2019.)

A floating pump-out station is a barge with a big tank which can be emptied with a specific maintenance ship or it can be towed to shore for emptying. (Website of Pidäsaaristo siistinä 2019.) Pictures 9a and 9b show a recent example of this kind of a pump-out station in Rauma. The pump-out station is anchored by the Kuuskajaskari island during the boating season and it is toed to inland harbour for emptying and for winter docking. The barge has a holding tank with the volume of 6m³ and during the first season of usage (2018) only one emptying was needed, the tank being less than half full. The barge also has an integrated toilet that can be used by all visitors of the Kuuskajaskari island i.e. the barge is part of the visitor pier constructions.



island during the boating season and it is toed to inland harbour for emptying and for winter docking. The barge has a holding tank with the volume of 6m³ and during the first season of usage (2018) only one emptying was needed, the tank being less than half full. The barge also has an integrated toilet that can be used by all visitors of the Kuuskajaskari island i.e. the barge is part of the visitor pier constructions.

Pictures 9a, 9b. Toilet barge and pump-out station in Kuuskajaskari Rauma.
© Minna Keinänen-Toivola



A fixed onshore pump-out station can be located on a fixed or floating dock but it always has a fixed pipeline connection to an onshore tank and possibly further connection directly to the municipal sewage system. This type pump-out station are usually easy to operate by both the boater and the port owner. In this case, the proper location must be studied carefully and depth must be adequate for sailing boats with higher draft. (Website of Pidä Saaristo Siistinä 2019.)

With a fixed but floating onshore station, there may be a need to remove the pipeline connection for wintertime to prevent ice from breaking the piping system. This kind of pump-out station was installed to Gävle city port (see pictures 10a and 10b). This small port is located by the estuary of Gävle river i.e. the pump-out dock must be removed for the winter to prevent the moving ice from breaking the system.

Generally, the fixed installations have higher installation costs but lower maintenance costs, where as floating or portable tank type systems have conversely lower installations costs but higher maintenance costs.

Portable wheeled pump-out stations are handy since they can be towed to a pier and to boats for emptying the septic tanks. On the other hand, portable stations have limited holding tank capacity, which can make them a difficult solution for ports with more than a few boats. Emptying the holding tank of these portable pump-out stations is done manually to municipal sewage or bigger storing tank onshore. (Website of Pidä saaristo siistinä 2019.)

More information on pump-out station solutions and their suppliers can be found on the web pages of Pidä Saaristo Siistinä ry or Håll Skärgord Ren rf association. The information on the pages is available in both Finnish and Swedish; in English the available information is more limited.



Pictures 10a, 10b. Municipality sewage connected septic waste pump-out station in Gävle city port.
© Marita Olsson Narving



Whatever technology is chosen very important is that the pump-out station is easy to access and use, it works reliably, spare parts are available and maintenance and repair of the station works when needed. No one likes pump-out station that is full, malfunctioning, out of order or dirty, especially when we are dealing here with sewage waste. Boaters rely on functional pump-out facilities and in worst case, boater ends up dumping the waste to sea.



6 PURCHASING PROCESS

An examination of the purchasing process in terms of collaborative procurement for small ports in the Baltic Region was completed in the Deliverable T2.4.1 Report on First Level Investments - Technology and Best Practices (Autumn 2017). During the period of October 2017 and December 2018, the small ports have made procurement decisions as part of the Central Baltic PortMate investment schedule. This section will summarize the lessons learned with the objective of providing practical guidance on the purchasing processes related to small ports. Reference to several intuitive procurement models will also guide other small ports in their future investment decisions.

Lessons learned

The knowledge transfer and handover of responsibility for future purchasing, and also the handover and responsibility for ongoing maintenance work needs to be specified early on in the project (so that investment initiatives are not left hanging). During the tendering process, more time needs to be reserved for potential complaint from suppliers, particularly for port investments in public municipalities. A key lesson learned is that more effort and time is needed in the beginning of the investment process to assess technical requirements of all procurement, including costs and time scheduling. In terms of Central Baltic funding, flexibility in transferring allocated funds from one investment procurement item to another (which may incur higher than estimated costs during the installation) is absolutely necessary. Some purchases end up requiring more resources than others, despite the initial investment planning. In addition, small port funding requires more resources allocated for salaries for investment and purchasing assistance, as the ideal of collaborative procurement between ports requires time and effort and concomitant human resources.

Purchasing Process Development

Going forward into the future, small ports need to use the experiences of other small ports in the region to streamline and enhance their own purchasing processes. Small ports are encouraged to collaborate and openly communicate and share, at a minimum, technical specifications, tendering details, supplier information, and matters of pricing.

There are several other matters to consider when developing the purchasing process of a small port. These can be summarized in terms of 1) strategic versus operative procurement and analysis of the supply chain of the port, 2) managing purchasing portfolio including local procurement and related social and economic impact of the procurement strategies of small ports, 3) purchasing habits and practices of small ports.

The examination supply chain of the small port will help situate the various elements of the purchasing process, from the initial specification and supplier pre-selection to the maintenance an installation activity downstream. Not only is it useful to differentiate between strategic and basic operative purchases, the small port can also determine which activities in the supply chain are strategic and which activities are operative and “business as usual” (Figure 5).

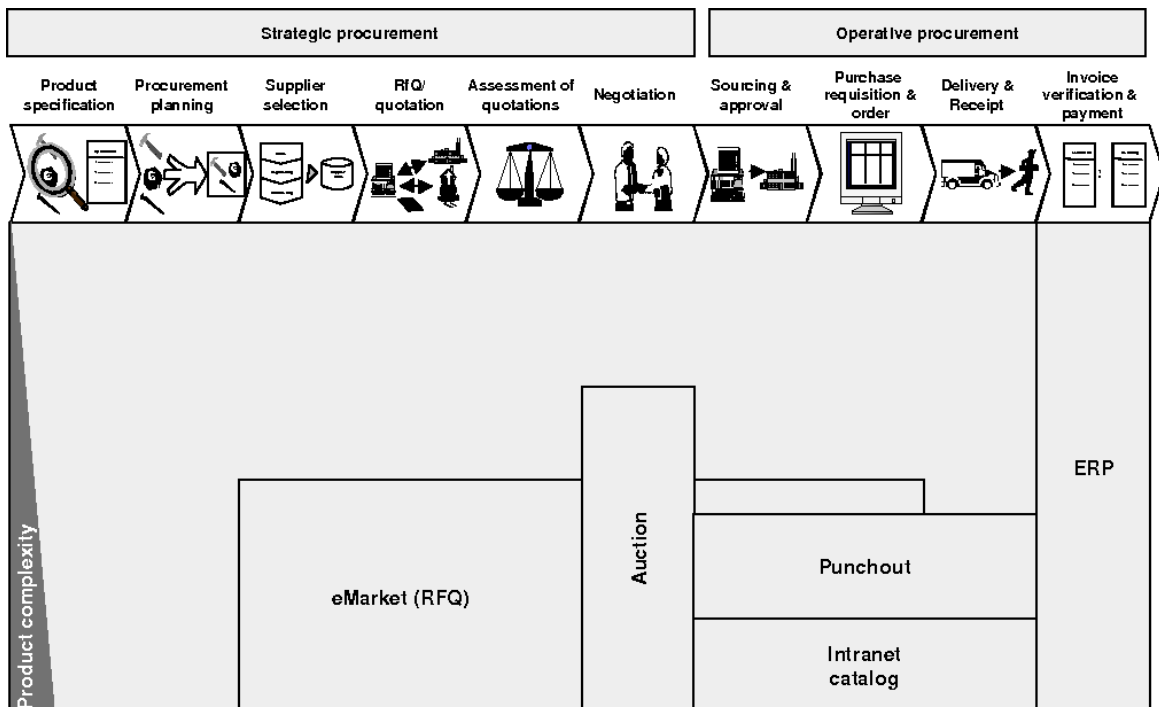

Figure 5. Supply Chain Processes and Procurement Strategies (Puschmann, 2005)

The Central Baltic PortMate project emphasizes resource efficiency and sustainability. Ports may also want to include a local content element into their purchasing process, which is a move towards economic and social sustainability. Esteves and Barclay (2011) recommend mapping investment purchases based on supply risk versus profit impact and categorizing the purchases into a) leverage b) strategic c) non-critical, and d) bottleneck, in terms of the specific approach to be taken with suppliers. Small ports can also classify purchases in this manner and develop their own portfolio of purchasing strategies. For example, the floating bridges and electrification initiatives can be seen as strategic in nature, where higher risk and low profit impact purchases such as payment systems are more of a bottleneck. Once the purchases of the ports are positioned in this way, there are several steps small ports can take to integrate social and economic impact assessment into their purchasing processes and strategies (Figure 6).

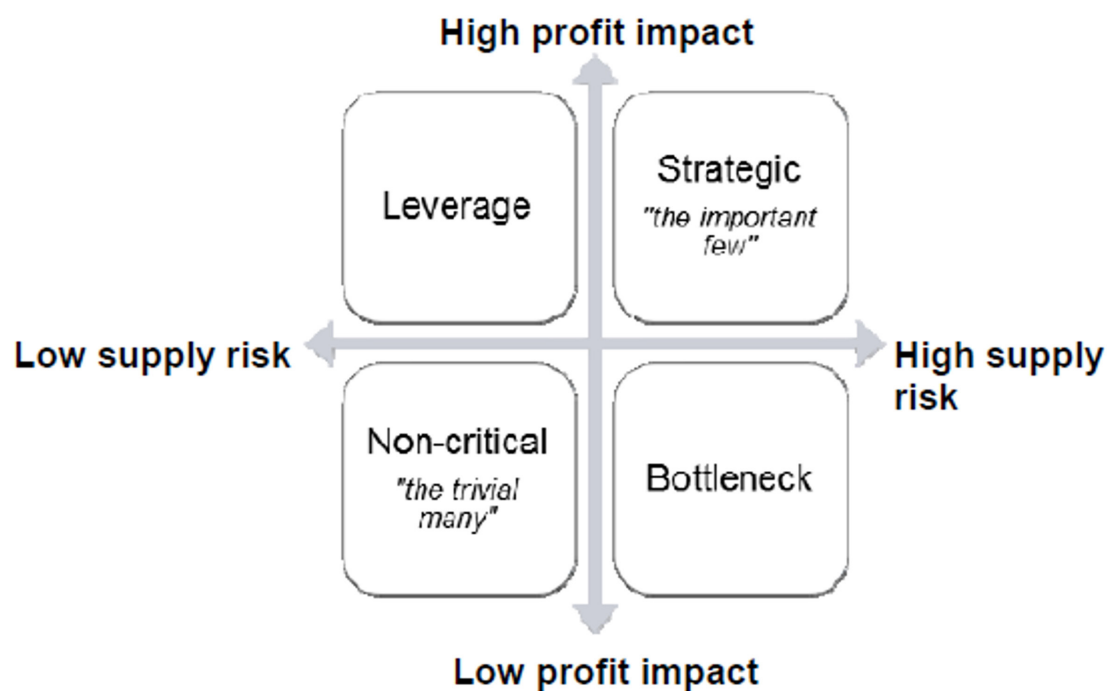

Figure 6. Purchasing Portfolio Management Model (Esteves 2011)

Purchasing habits of small ports can be examined through the “Buying Behaviour of SME” model put forth by Ozmen (2014). Here the culture, ownership of the port, decision-making structures of the port, the need for the purchases including their significance, the attitudes towards buying, and stimuli from the environment are all assessed by the port to not only get a better understanding of their purchasing process, but to improve and develop their investment and procurement activities overall. (See Figure 7). Looking at the purchasing practices of small ports, there are three fundamental practices that include the degree to which purchasing itself

is seen as a “strategic” activity by the ports, the evaluation of the small ports of existing supplier relationships, and the assessment of the supplier capabilities by the small ports (Pressey, 2009).

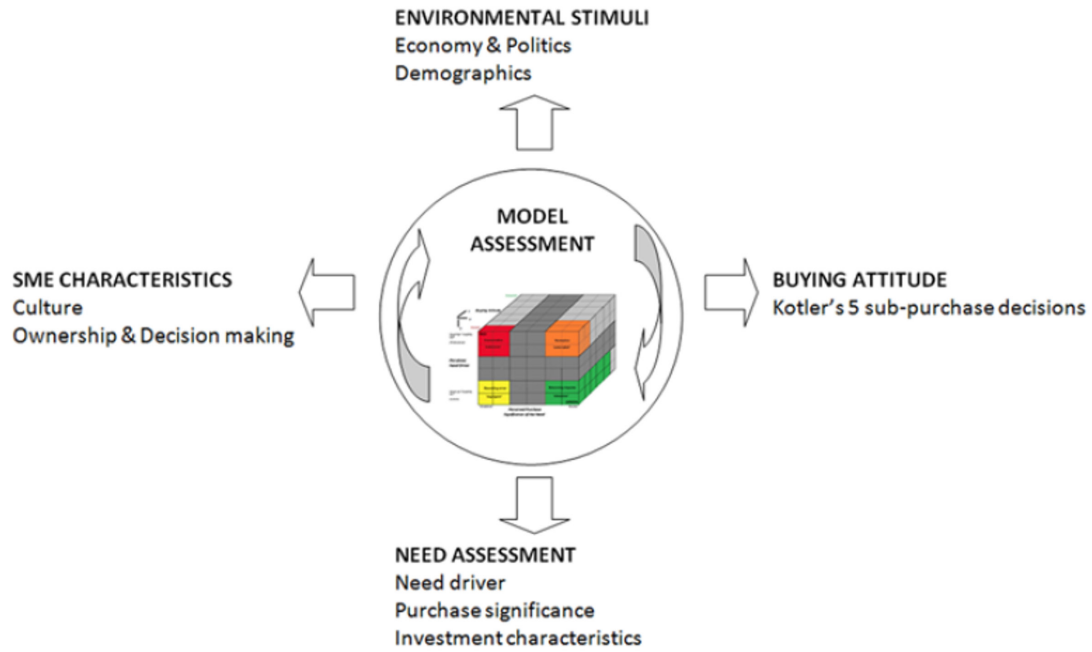

Figure 7. Buying Behaviour of SMEs (Ozmen 2014)



7 CONCLUSIONS

LED lighting is a mature and durable resource efficiency technology that can be easily applied in small ports. There are both replaceable LED light bulbs which can be used in existing light fittings, and LED lights with fixed LED fixtures with which the complete light device needs to be replaced. While LED lighting offers the possibility to choose different light colours and shades, the different characteristics stated in lamp packagings can first seem a bit complex – however, studying the details will give the user lots of beneficial information. When installing LED lights outdoors make sure they are suitable for outdoor use (IP Code). Light only the area needed (e.g. pathway), not the surroundings, and thus avoid creating light pollution.

PV solar energy solutions fit well to small ports due to the good production-consumption match with available solar resource of the boating season and the amount of energy needed. Off-Grid PV can be the solution for providing electricity to a port without existing power network and with On-Grid solution port can replace substantial share of the consumed electricity of the site. When installing a PV system, the panels should be installed firmly and in a place where there is minimum shading during the day and the season. The inverter should rather be in the shade and be of weatherproof type if installed outdoors. Or, if installed indoors, a place with good ventilation should be chosen.

When planning on investing in a pump-out station it is important to examine which type of pump-out station works best for the port in question. The decision depends among other things on the occupation rate of the port and the existing infrastructure available for sewage waste handling. Whatever technology is chosen, it is important that the pump-out station is easy to access and use, it works reliably, spare parts are available and maintenance and repair of the station works well.

REFERENCES

Aaltonen, T. 2018. Lisää valoa ulos. TM Rakennusmaailma 31.10.2018.

Act on Environmental Protection in Maritime Transport 1672/2009. <https://www.finlex.fi/en/laki/kaannokset/2009/>

Asetus 435/2000. Käymäläjäteveden päästäminen veteen aluksista. Act on draining septic waste to waters. 2000. A 435/2000. <https://www.finlex.fi/fi/laki/alkup/2000/20000435>

Connecticut Department of Energy & Environmental Protection. 2000. A Guidebook for Marina Owners and Operators for the Installation and Operation of Sewage Pumpout and Dumping Stations. Referred 7.1.2019. https://www.ct.gov/deep/lib/deep/long_island_sound/cva/Guidebook_for_Marina_Owners_and_Operators.pdf

Dersten, R. – Heikkinen, T. – Kortelainen, K. – Keinänen-Toivola, M.M. 2018. Perfect small port within resource efficiency – Best practices and sustainability. Central Baltic PortMate. Series B, Reports 11/2018. Satakunta University of Applied Sciences. Pori.

Esteves, A.M. and Barclay, M.A., (2011.) Enhancing the benefits of local content: integrating social and economic impact assessment into procurement strategies. *Impact Assessment and Project Appraisal*, 29(3), pp. 205-215.

Ozmen, E. S. et al. (2014). 'SMEs' Purchasing Habits: A Procurement Maturity Model for Stakeholders', *SAGE Open*. doi: 10.1177/2158244014536405.

Photovoltaic Geographical Information System (PVGIS). European Commission Joint Research Centre. 2019. Referred 14.1.2019. http://re.jrc.ec.europa.eu/pvg_tools/en/tools.html#PVP

Pressey, A. D., Winklhofer, H. M., & Tzokas, N. X. (2009). Purchasing practices in small-to medium-sized enterprises: An examination of strategic purchasing adoption, supplier evaluation and supplier capabilities. *Journal of purchasing and supply management*, 15(4), 214-226.

Puschmann, T. and Alt, R. (2005). Successful use of e-procurement in supply chains. *Supply Chain Management: an international journal*, 10(2), pp.122-133.

SFS-EN 60529. Degrees of protection provided by enclosures (IP code). 2000. Finnish Standards Association SFS. Helsinki: SFS. Referred 22.1.2019. <http://www.sfs.fi/>

Svenska båtunionen. 2015. Hamnar för fritidsbåtar. Stockholm. (Guidance document for recreational boat ports by Swedish boating union). Referred 7.1.2019. <http://www.batsam.com/ovrigt/Hamnhandboken2016.pdf>

Website of General Lamps. Referred 3.1.2019. <https://www.lamps-on-line.com/colour-rendering-index>

Website of Lampputieto.fi. Referred 3.1.2019. <https://lampputieto.fi/lampun-valinta/lamppujen-pakkausmerkinnat/>

Website of Lighting design lab. Referred 22.1.2019. <https://www.lightingdesignlab.com/>

Website of Motiva. Referred 20.12.2018. https://www.motiva.fi/koti_ja_asuminen/hyva_arki_kotona/lamput_ja_valaistus

Website of Pidä Saaristo Siistinä ry. Keep Archipelago Tidy Association, Finland. Referred 17.1.2019. https://www.pidasaaristosiistina.fi/ymparistotietoa/tietoa_satamille/veneiden_kaymalajatteen_vastaanotto_satamassa

Website of Suomen valoteknillinen seura (Illuminating Engineering Society (IES) of Finland). Referred 20.12.2018. <https://valosto.com>

Website of The Enclosure company. Referred 22.1.2019. <http://www.enclosurecompany.com/ip-ratings-explained.php>

Website of TUKES. Finnish Safety and Chemicals Agency. Referred 3.1.2019. <https://tukes.fi/en/home-and-leisure-time/restoration-and-renovation/do-it-yourself-electrical-work>

Website of TUKES. Referred 11.1.2019. <https://tukes.fi/en/home-and-leisure-time/restoration-and-renovation/do-it-yourself-electrical-work>

This report provides general information on resource efficient solutions for small ports. The aim of the guide is to introduce resource efficient technologies, for example LED lighting and solar energy solutions, and to give practical guidance on choosing, purchasing and installing them. Practical examples are given in the form of the technologies that have been installed in the Central Baltic PortMate project pilot ports to enhance resource efficiency.

ISSN 2323-8356 | ISBN 978-951-633-272-0 (pdf)

samk

