

Romppainen Samuli

# **Wireless Communication Network**

Thesis

Spring 2020

School of Technology

Automation Engineering



SEINÄJOEN AMMATTIKORKEAKOULU  
SEINÄJOKI UNIVERSITY OF APPLIED SCIENCES

SEINÄJOKI UNIVERSITY OF APPLIED SCIENCES

## **Thesis abstract**

Faculty: School of Technology

Degree Programme: Automation Engineering

Specialisation: Electrical Automation

Author: Romppainen Samuli

Title of thesis: Wireless Communication Network

Supervisor: Hietamäki Marko

Year: 2020 Number of pages: 52

---

The mandator of the thesis was Seinäjoki University of Applied Science. The purpose of the thesis was to find out if it is possible to create a wireless communication network by using different type of wireless power control switches from different manufacturers.

EnOcean is a company that develops actuator and sensor devices. In the thesis project an EnOcean actuator was combined with Beckhoff devices that are designed to cooperate with the EnOcean antenna. The switches and sockets used in the work were made by different manufacturers and produced by according to the required standards. They made the building of the wireless communication network possible. By using natural power sources, the switches generate the needed amount of energy for sending a data signal that is needed to control the electricity flow in sockets and to monitor the state of doors and windows. The goal of the work was to program a modifiable operating system with Beckhoff TwinCAT 3, with the help of which it is possible to define the actions for each device.

The thesis studied the necessary theory on electromagnetic waves, concentrating on how and in what form the data signal is transmitted and received in devices. The thesis explained all the steps needed for installing devices, and studied how the operating system is programmed.

Keywords: TwinCAT 3, EnOcean, electromagnetic wave, communication network, Beckhoff, program, operating system, data, transmit, receive, antenna

SEINÄJOEN AMMATTIKORKEAKOULU

## Opinnäytetyö tiivistelmä

Koulutyksikkö: Tekniikan yksikkö

Tutkinto-ohjelma: Automaatiotekniikka

Suuntautumisvaihtoehto: Sähköautomaatio

Tekijä: Romppainen Samuli

Työn nimi: Langaton viestintäverkko

Ohjaaja: Hietämäki Marko

Vuosi: 2020 Sivumäärä: 52

---

Opinnäytetyön toimeksiantajana toimi Seinäjoen Ammattikorkeakoulu. Opinnäytetyön tarkoituksena oli selvittää, onko mahdollista rakentaa langaton viestintäverkko sähkönojaukseen tarkoitettuja langattomia kytkimiä eri valmistajilta käyttäen.

EnOcean on yritys, joka valmistaa toimilaitteita ja antureita. Tässä työssä EnOcean toimilaitte liitettiin Beckhoffin laitteiden kanssa, jotka on suunniteltu toimimaan yhdessä EnOcean antennin kanssa. Työssä käytettiin eri valmistajien kytkimiä ja pistorasioita, jotka on valmistettu vaadittujen standardien mukaisesti. Niiden avulla langattoman viestintäverkon rakentaminen oli mahdollista. Kytkimet tuottavat luonnollisia energian lähteitä käyttäen tietosignaalin lähettämiseen tarvittavan energian, joka tarvitaan, energian kulun ohjaamiseen pistorasioissa ja ovien tai ikkunoiden tilan seuraamiseen valvontanäytöltä. Työn tavoitteena oli ohjelmoida Beckhoff TwinCAT 3:a käyttäen muokattava käyttöjärjestelmä, jonka avulla voidaan määrittää toiminnot jokaiselle laitteelle.

Opinnäytetyössä tutkittiin sähkömagneettisiin aaltoihin liittyvää teoriaa keskittyen siihen, kuinka ja missä muodossa tietosignaalit siirretään ja vastaanotetaan laitteissa. Työssä selvitettiin laitteiden asennukseen tarvittavat vaiheet ja tutkittiin, kuinka käyttöjärjestelmä on ohjelmoitu.

Avainsanat: TwinCAT 3, EnOcean, sähkömagneettinen aalto, viestintäverkko, Beckhoff, ohjelma, käyttöjärjestelmä, tieto, siirto, vastaanotto, antenni

## TABLE OF CONTENTS

|   |           |
|---|-----------|
| Thesis abstract.....                                    | 2         |
| Opinnäytetyö tiivistelmä.....                           | 3         |
| TABLE OF CONTENTS .....                                 | 4         |
| Figures .....   | 6         |
| Terms and Abbreviations.....                            | 8         |
| <b>1 INTRODUCTION .....</b>                             | <b>10</b> |
| 1.1 Background.....                                     | 10        |
| 1.2 Goal .....  | 10        |
| 1.3 Structure .....                                     | 10        |
| <b>2 WIRELESS COMMUNICATION.....</b>                    | <b>12</b> |
| 2.1 History of electromagnetic waves.....               | 12        |
| 2.2 Electromagnetic waves .....                         | 12        |
| 2.3 Distractions for electromagnetic waves.....         | 14        |
| 2.4 The structure of electromagnetic waves.....         | 15        |
| 2.5 Examining Values .....                              | 16        |
| 2.6 Arranging waves by their frequency and length ..... | 17        |
| 2.7 Antenna.....  | 18        |
| 2.8 DIGITAL DATA.....                                   | 20        |
| 2.9 Data exchange .....                                 | 20        |
| 2.10 My point of view .....                             | 21        |
| <b>3 MANUFACTURERS AND INSTRUMENTS.....</b>             | <b>22</b> |
| 3.1 EnOcean .....                                       | 22        |
| 3.1.1 TCM 320 .....                                     | 22        |
| 3.2 Beckhoff .....                                      | 23        |
| 3.2.1 The IPC Company .....                             | 23        |
| 3.2.2 The I/O Company.....                              | 23        |
| 3.2.3 The Motion Company.....                           | 23        |
| 3.2.4 The Automation Company .....                      | 24        |
| 3.2.5 Beckhoff Master terminal KL6581 .....             | 24        |
| 3.2.6 Beckhoff BK1120 Bus Coupler.....                  | 24        |

|   |    |
|---|----|
| 3.2.7 Beckhoff KL6583_1.....  | 25 |
| 3.2.8 Beckhoff KL9010 End terminal.....                             | 25 |
| 3.2.9 TwinCAT 3 .....   | 25 |
| 3.3 ELTAKO.....   | 25 |
| 3.3.1 FFT55Q-button .....   | 26 |
| 3.3.2 FTKE-button.....  | 26 |
| 3.3.3 FSVA and FSUD-socket .....                                    | 27 |
| 3.4 Appurtenance.....   | 27 |
| 4 ENOCEAN RADIO PROTOCOL .....                                      | 28 |
| 5 INSTRUCTIONS FOR THE WORK.....                                    | 29 |
| 5.1 Devices and data actions .....                                  | 29 |
| 5.1.1 Receiving and transmitting information .....                  | 30 |
| 5.1.2 From antenna to PLC.....                                      | 31 |
| 5.2 Scanning devices and adding EnOcean library.....                | 33 |
| 5.3 Linking the master terminal and the master function block ..... | 34 |
| 5.4 Programming.....  | 36 |
| 5.4.1 FB_KL6581 function block .....                                | 37 |
| 5.4.2 FB_Send_RPS_Switch function block .....                       | 38 |
| 5.4.3 FB_EnOcean_Search .....                                       | 40 |
| 5.5 Structured text EnOce .....                                     | 41 |
| 5.6 Virtual apartment panel .....                                   | 43 |
| 5.7 Adding new devices and modifying the program.....               | 44 |
| 5.8 Paring sockets from PLC .....                                   | 45 |
| 5.9 Apartment layout.....   | 46 |
| 6 RESULTS AND SUMMARY .....   | 50 |
| 6.1 Results .....   | 50 |
| 6.2 Summary.....  | 50 |
| REFERENCES.....   | 52 |

## Figures

|   |    |
|---|----|
| Figure 1. Electromagnetic Wave .....                        | 13 |
| Figure 2 Horizontal polarization electromagnetic wave ..... | 14 |
| Figure 3 A structure of an electromagnetic wave .....       | 15 |
| Figure 4. One period of a wave .....                        | 16 |
| Figure 5 A spectrum of different frequencies .....          | 17 |
| Figure 6 A charged conductor antenna .....                  | 18 |
| Figure 7 An antenna is generating signal waves.....         | 19 |
| Figure 8 Data from electricity to digital.....              | 20 |
| Figure 9 All data transmits through antenna .....           | 27 |
| Figure 10 EnOcean signal protocol.....                      | 28 |
| Figure 11 EnOcean signal protocol in timeline.....          | 28 |
| Figure 12 Signal leaves from buttons toward a socket.....   | 30 |
| Figure 13 Components and information feedback .....         | 32 |
| Figure 14 TwinCAT XAE Project (XML format) .....            | 33 |
| Figure 15 Scanned devices .....                             | 34 |
| Figure 16 EnOcean library .....                             | 34 |
| Figure 17 Global variables .....                            | 35 |
| Figure 18 Change link.....                                  | 35 |
| Figure 19 Digital KL_6581 function block.....               | 36 |
| Figure 20 Main program (CFC) .....                          | 37 |

|   |    |
|---|----|
| Figure 21 FB_6581 .....                             | 37 |
| Figure 22 FB_Send_RPS_Switch.....                   | 38 |
| Figure 23 KL_6583_1 actuator.....                   | 39 |
| Figure 24 FB_EnOcean_Search.....                    | 40 |
| Figure 25 EnOce.....                                | 41 |
| Figure 26 Input value received by the antenna ..... | 42 |
| Figure 27 Structured text function block.....       | 42 |
| Figure 28 TwinCAT 3 visualization.....              | 43 |
| Figure 29 Apartment layout.....                     | 47 |
| Figure 30 Data signal cannot get through .....      | 48 |
| Figure 31 Second transmitting antenna .....         | 49 |

## Terms and Abbreviations

|                         |  |
|-------------------------|--|
| <b>AC</b>               | Form of electricity the flow direction of which changes in frequently                        |
| <b>BIT</b>              | Basic unit of information. Represents a logical state, having only one of two values 0 or 1. |
| <b>BOOL</b>             | In TwinCAT 3 programming software BOOL represents BIT.                                       |
| <b>BYTE</b>             | Consist of 8 bits.   |
| <b>CFC</b>              | Continuous Function Chart.   |
| <b>CX-version</b>       | Beckhoff embedded PC that contains a PLC.  |
| <b>Data</b>             | Is a form that contains information.   |
| <b>DC</b>               | Form of electricity the flow direction of which is stable and does not change.               |
| <b>EnOce</b>            | Programmed subprogram function block by the user.  |
| <b>Function block</b>   | Graphical language for programmable logic controllers.                                       |
| <b>ID</b>               | Device Identification.   |
| <b>Input</b>            | Data that is received into a program or device.  |
| <b>I/O</b>              | Input/Output.  |
| <b>Operating system</b> | Programmed interface in TwinCAT 3.   |
| <b>Output</b>           | Data that is transmitted out from a program or device.                                       |
| <b>PC</b>               | Personal Computer.   |



|                            |   |
|----------------------------|---|
| <b>PLC</b>                 | Programmable Logic Controller.  |
| <b>Program</b>             | Synonym for an operating system that can be programmed to control input and output data.                            |
| <b>Receiver</b>            | Receives signals.   |
| <b>Smart house</b>         | Modern house where automation devices control the actions of different electric devices.                            |
| <b>ST</b>                  | Structured text.  |
| <b>Subprogram</b>          | Process reads the main program when running, and a subprogram is a separate program that the main program can read. |
| <b>Transceiver</b>         | Also called an antenna. Transceiver is capable to transmit and receive signals                                      |
| <b>Transmitter</b>         | Transmits signals.  |
| <b>TwinCAT 3</b>           | Programming software for Beckhoff devices.  |
| <b>WORD</b>                | Consist of 16 bits.   |
| <b>x, y, z -directions</b> | 3 different dimension x = left and right, y = up and down, z = forward and backwards.                               |

.

.

# 1 INTRODUCTION

## 1.1 Background

The thesis is done for Seinäjoki University of Applied Science. The school had all the necessary devices and software for building a wireless communication network to be used for teaching purposes with the upcoming students. The future world is evolving and our technology is developed to be more and more economic. Devices use less and less electricity in use which means that the need for generating electricity is also going lower and lower. The school needs to evolve with the world and wireless networks for controlling the consumption of electricity in new smart houses and buildings are becoming more and more common.

## 1.2 Goal

The goal of the thesis was to apply and use the gathered information to create a platform software for a wireless communication network that can benefit in new offices designing, teaching purposes and later updated for next generation students and teachers. Design a wireless communication network by using battery-less devices that are capable to receive and transmit data signals and program a modifiable operating system that controls the actions of each device in the designed communication network.

## 1.3 Structure

The work goes through the history and structure of electromagnetic waves. It concentrates on how electromagnetic waves behave, which purposes the waves are used for and how data can be transmitted wirelessly? Attention is also paid to how computers receive data from outside and how computers process the data. The thesis introduces manufactures that design devices that are capable to communicate wirelessly and necessary for creating a wireless communication network. It is also explained how signal receiver devices read the signal and which steps need to

be taken when creating and programming a modern wireless communication network for an apartment.

## **2 WIRELESS COMMUNICATION**

### **2.1 History of electromagnetic waves**

In 1873 a Scottish scientist James Clerk Maxwell published a research on electromagnetic waves. A purely theoretical research predicted the existence of electromagnetic waves moving by the speed of light (approximately 300 000km/s) through the air. A German physicist Heinrich Hertz managed to prove the existence of electromagnetic waves. Hertz proved that Maxwell's theory was correct but, even though Hertz was an excellent and smart scientist at the time and proved the existence of electromagnetic waves by practical experiments, he said that there is no use for electromagnetic waves, and that this had just been a test that proved Maxwell to be correct (Lainanen 2018, 19 - 20.) There is no need for practical tests to prove that what Hertz said is far from true.

### **2.2 Electromagnetic waves**

Imagine dropping a stone into a lake. The surface of a lake starts to wave. This phenomenon is similar with what happens in electromagnetic waves but instead of waving only in y-direction and moving to x-direction (up/down and forward/backward) electromagnetic waves contains a third wave (magnetic wave) that is moving in z-direction (sideways left/right). Electric waves (y) and magnetic waves (z) are linked to each other. Magnetic waves generate electrical waves and electrical waves generate magnetic waves. Both electric and magnetic waves pull each other towards themselves and pass each other at the centre (x-direction). This will start a loop where the waves pass the centre from the lowest amplitude to the highest and back to the lowest and this goes on and on. (NASA SCIENCE 2016.)

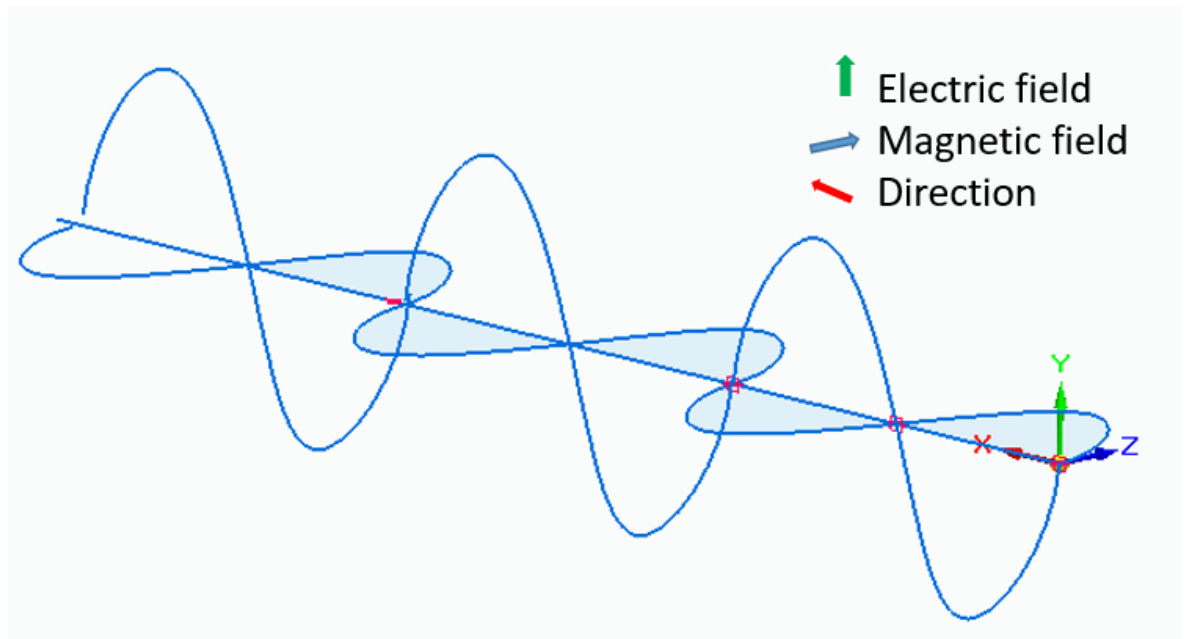

Figure 1. Electromagnetic Wave

If a wave that is generated from dropping a stone into a lake hits a rock wall, the wave naturally splashes and stops moving forward. Electromagnetic waves do not need mediums to propagate so they are able to move through solid matters and even in the vacuum of space (NASA SCIENCE 2016).

Electromagnetic waves can be polarized in the same way as light waves, because electromagnetic waves are one form of light. This means that it is possible to reject a wave instead of letting it pass through. Think of throwing a frisbee at a picket fence. In one orientation it will pass through, in other it will be rejected. The same method is used in sunglasses (NASA SCIENCE 2016).

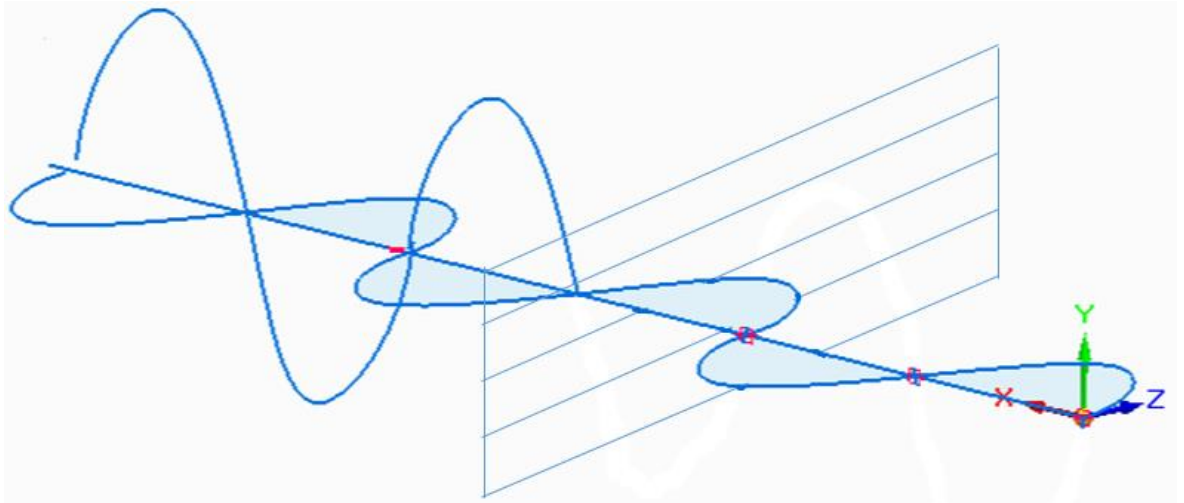

Figure 2 Horizontal polarization electromagnetic wave

Observe the figure 2. In the case of polarization electromagnetic wave, the polarization defines how the direction of an electric field behaves in the function of time. In figure 2, the electric wave is in vertical polarization which means that the direction of the electric wave is always the same. By turning the electric wave 90 degrees a horizontal polarization wave would be achieved. It is good to remember that in horizontal polarization the electric wave waves also in the upward direction (y) because the magnetic wave is then in up-side direction (y) (Lehto 2016, 59-60.)

### 2.3 Distractions for electromagnetic waves

Practically electromagnetic waves move close to the earth surface. In addition to the atmosphere, the structure of the earth surface, electric features of the ground, vegetation and buildings may affect the motion of the waves. Because the surface of earth is curved, a straight connection between transmitters and receivers is tens of kilometres at the best, when at least one of the antennas is installed high from the ground. If the communication distance is not completely free the information flow may not break completely because the waves have an ability to pass through solid matter or end behind objects by way of diffraction. Diffraction is a phenomenon when the wave encounters through a slit and the size of the slit is proportional for the length of the wave and this will define if the wave starts to bend around from the

corners of the slit (Lehto 2016, 62-62). The reflections from the earth surface and buildings may be beneficial or harmful. A wave may bounce to another direction, but it can also get to places where reflection is necessary for accessing. (Lehto 2016, 81-82.)

## 2.4 The structure of electromagnetic waves

The basic properties of a wave consist of an amplitude for both the magnetic wave (M) and the electric wave (E). The length of a wave (A) and the x-line line represent time, or the x-line can also be thought as the direction where the wave is moving. The x-line also represents the 0-point. The 0-point is equally as far from the highest point of a wave as from the lowest point of a wave. The shorter the wavelength is the more energy the wave contains and the amplitude measures how strong the wave is (Lehto, 59.) This can be seen in figure 3

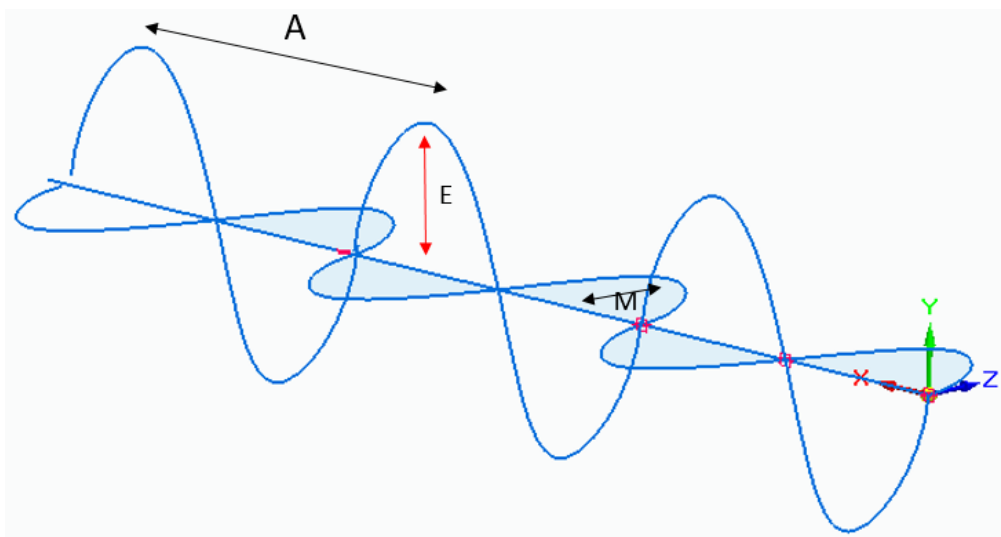

Figure 3 A structure of an electromagnetic wave

The period of a wave starts from the 0-point, rises to the highest amplitude, drops then to the lowest amplitude and rises back to the 0-point, where the wave started but ends in a different position on the timeline. A period of a wave is shown in figure 4.

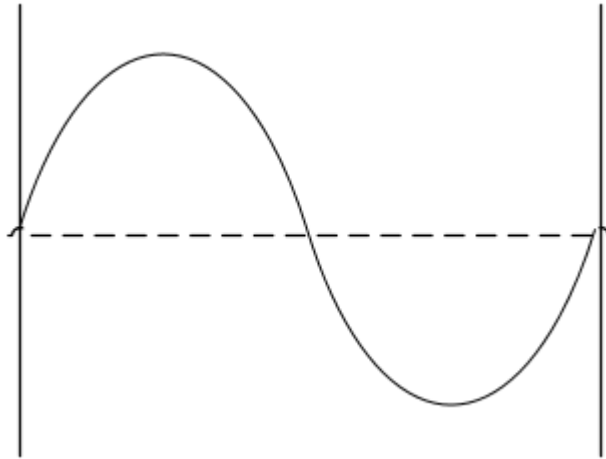

Figure 4. One period of a wave

## 2.5 Examining Values

Humans have discovered and given a certain value for the speed of light that is necessary for calculating the length of a wave ( $A$ ) or the frequency of a wave ( $f$ ). In 1983 the speed of light was defined to move 299 792 458 m/s. At the same time a meter (m) was defined to measure the distance that light moves in a vacuum on the timeline of  $1/299\,792\,458$  seconds (Lehto, 58 2006.)

$$c = Af \quad (1)$$

By modifying the formula (2), the frequency of a wave and the length of a wave can be counted. By measuring the wavelength and counting how many waves 1 second includes can be solved the frequency ( $f$ ) of the wave. A period ( $T$ ), a frequency ( $f$ ) and the units of a period are measured in seconds (s) (Lehto, 58-59.)

$$T = 1/f \quad (2)$$



## 2.6 Arranging waves by their frequency and length

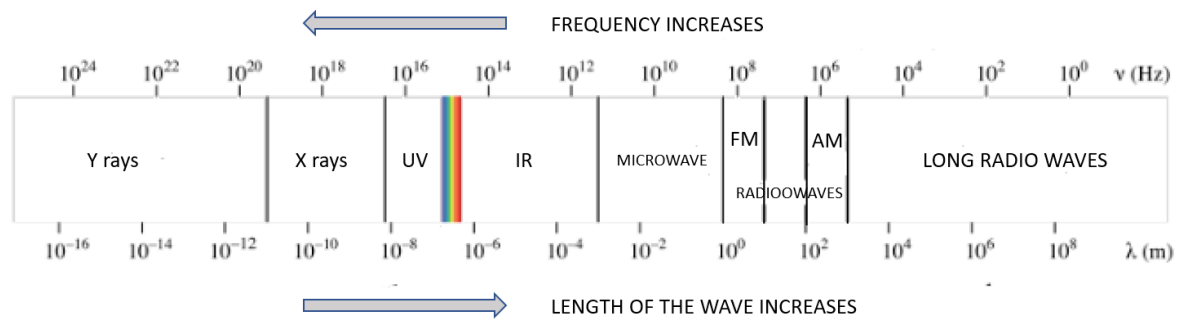

Figure 5 A spectrum of different frequencies

When increasing frequency in waves, the length of a wave period lowers and vice versa. Figure 5 describes the purposes electromagnetic waves are used for in our lives:

**Radio waves** have to longest wavelength and the highest amplitudes. Radios that people use for listing music or news are using the frequency of the radio waves (NASA SCIENCE 2016.)

**Microwaves** are most commonly used for heating food in a microwave and are beneficial for studying earth form space because the right frequency of microwaves can penetrate haze, light rain and snow, clouds and smoke (NASA SCIENCE 2016.)

**IR** comes from the word infrared. It is similar to the light colour waves. The colour waves of light are visible for human eye and can be felt as heat on our skin. Infrared is the warmest of the colour waves of light, but it is invisible for human eye to see. It is most commonly used in remote controllers. (NASA Science 2016.)

**UV** stands for ultraviolet light, which is the opposite of infrared. UV waves come from our sun. UV is harmful for humans and for the atmosphere of our planet. UV is the reason why the skin can burn when the it is exposed to it for a too long time. (NASA Science 2016.)

**X-ray's** wavelength starts to get very low. It is approximately between 0.03 and 3 nano meters. It is so small that some of the waves are of the size of an atom of

many other elements. This is most commonly used in medical operations like shooting x-rays to a leg to see the condition of a bone. (NASA Science 2016.)

**Y-rays are** also known as gamma rays. Gamma rays have one of the most frequent frequency and the lowest wavelength from the discovered electromagnetic waves. The hottest and most energetic objects like a supernova explosion from a star, or the regions of black holes are generating gamma rays. On our planet gamma rays are produced by nuclear explosions or lightnings. (NASA Science 2016.)

## 2.7 Antenna

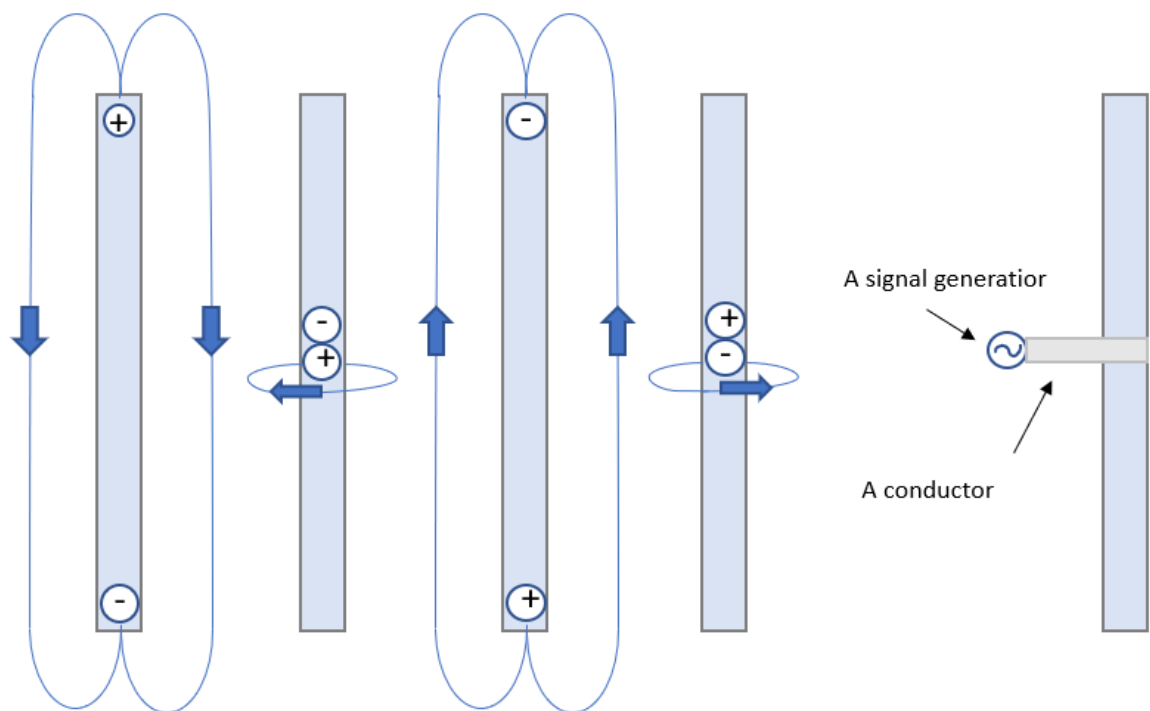

Figure 6 A charged conductor antenna

For gathering information from the air, any material capable of conducting electricity is suitable. Antenna is charged with electricity. Electrons in an antenna pull each other towards each other, start moving back and forth and are then in an accelerating state. This phenomenon generates waves moving away from the antenna. Making the vibration of the electrons continuous is sin formed varying high frequency fed from a signal generator to the antenna. (Lehto 2006, 78.) Figure 7 expresses how an antenna creates electromagnetic waves.

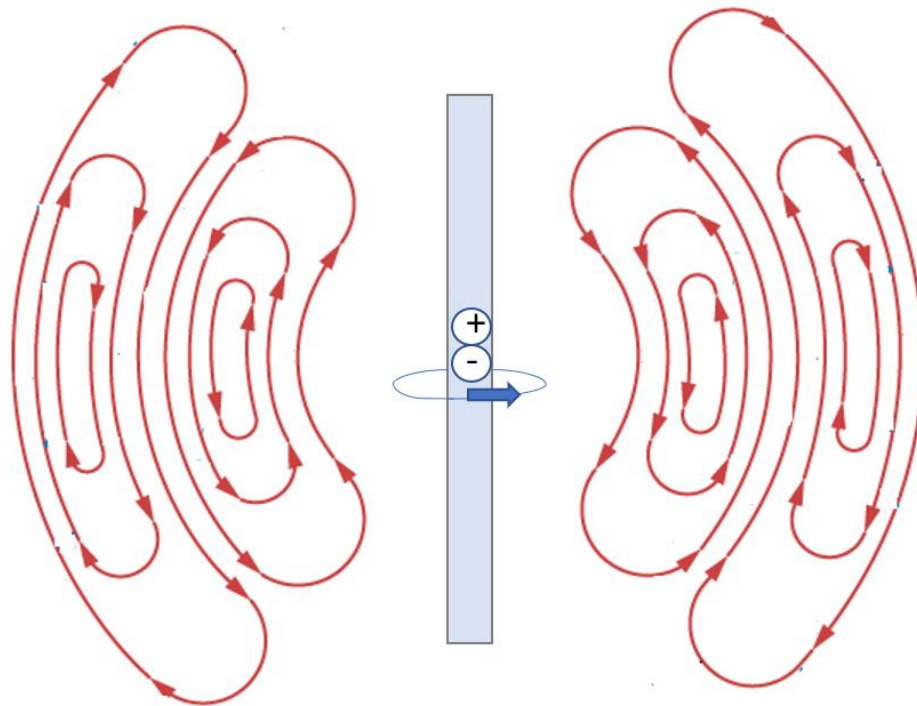

Figure 7 An antenna is generating signal waves

In this project the used antenna is a transceiver that can either receive or transmit electromagnetic signals. The designing is very similar but instead of only receiving electromagnetic waves from the air the transceivers has ability to generate electromagnetic signals from electricity. By adjusting the speed of how fast the (-) and the (+) electrons are switching sites in the wire (Lehto 2006, 78-79.) This phenomenon is very similar with blowing soap bubbles for example. If the bubble is blown with a great force it usually detaches with very small size. But if the blown is calm the size is usually be much bigger.

What happens when generating signal waves is that both (-) and (+) electrons are holding on from each edge of the bubble. When the electrons pass by each other at the middle point the bubble closes and separates to the air. The faster the movement the smaller the wave (bubble) size is. Receiving data while transmitting is not possible. (Lehto 2006, 77-78.)

Why for example the radio stations have so huge size of antennas and reminds a bowl. The reason is that the radio stations transmitted signals needs to be so strong that the signals can fly so large distances trough the Earth without having disruptions

and the bowl shape is beneficial for gathering electromagnetic waves from the air. (NASA SCIENCE 2016.)

## 2.8 DIGITAL DATA

The electromagnetic waves gathered from the air needs to be changed for readable form for a computer. The information inside a computer is in written in a base-2 binary numeral system or a binary numeral system. For communication a computer requires the information to be written in “marks” that consist of 8-bits and a mark is also called a byte. Inside a computer for each bit the computer contains an individual conductor. In electric form each bit is described as 1-bit equals to +5V voltage and 0-bit equals to 0V voltage. Inside a computer the data moves in 4 or 8-byte groups which constitutes a word (word, w). (Hakala. Vainio 2005, 44.) Figure 7 shows when a conductor is charged with 5V voltage and a computer reads it as a 1 and when charge in a conductor drops to zero a PLC reads it as a 0.

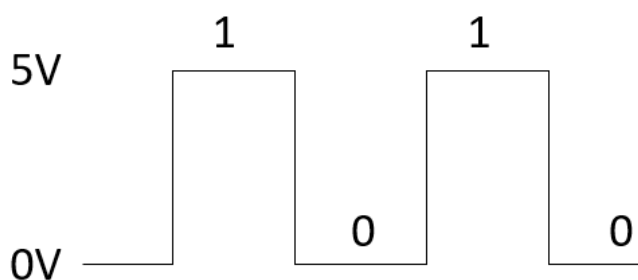

Figure 8 Data from electricity to digital

## 2.9 Data exchange

Electromagnetic waves move in a certain frequency (Hz) just like all waves. If a wave starts from a 0 point and rises to the highest amplitude and drops down to the lowest amplitude and then rises back to the 0 point where it started in 1 second of a time unit then the frequency is 1Hz (NASA 2018.) In this project the used frequency that is transmitted from a device travels in a frequency of 865MHz which means that the wave goes from 0-point to the highest amplitude drops to the lowest amplitude and rises back to the 0-point 865 000 000 times per second. s

## 2.10 My point of view

If a human eye could see the electromagnetic waves flying back and forth in the air, we probably could not see anything else. The whole planet would be covered with waves and most likely be black because there would be so many waves flying around all the time that most of us could not even imagine what is really happening. The benefit of these electromagnetic waves for humans is that they are so useful and helpful in our everyday life. Every mobile phone, internet and radio is somehow linked to these electromagnetic waves. Because the electromagnetic waves cannot vanish in a vacuum space they give us an opportunity to discover the space at such distances that take even from light years to travel. If a huge comet, like the one that wiped out all the dinosaurs, would approach the Earth humans could probably see it already years before it is even close and by using some mathematical formulas they could count its flying course and prepare for the impact for a long time.

The whole world is connected because of electromagnetic waves and the information takes only milliseconds to travel from the one side of the world to the other. The information spreads so fast that if someone posts a picture of him- or herself in the internet, the picture can be seen on the other side of the world in the next second and it might spread at the speed of light. So be smart and think what kind of information you send flying at the speed of light. Once it is in there it is almost impossible to get it out of there.

## **3 MANUFACTURERS AND INSTRUMENTS**

### **3.1 EnOcean**

EnOcean focuses on production and marketing wireless self-powered sensor solutions for battery-less applications in the internet of things (IoT). Offering modules for the wireless devices that are capable for generating power from natural sources, for example from kinetic movement. Devices can be from any manufacturer provided that they use the right standards to enable the wireless communication (EnOcean, [Ref. 29.01.2020].)

Internet of things (IoT) is a naming for application devices that are capable to communicate with each other and are connected to the internet (EnOcean, [Ref. 29.01.2020].)

#### **3.1.1 TCM 320**

A small actuator developed by EnOcean. The actuator contains a wire that is used as an antenna. The antenna catches the electromagnetic data signals from the air that are travelling in a right amount of frequency. (EnOcean [Ref. 29.01.2020].) EnOcean actuators are developed to work like a mail man to receive the data wave message and transmit the messages forward.

The TCM 320 is attachable actuator that requires a motherboard to operate. In this project the used mother board is KL6583\_1 developed by Beckhoff (KL6583\_1 is introduced in section, Beckhoff KL6583\_1). The received data signal frequency is different in each country in EnOcean actuators. TCM 320 is designed to catch only 865 MHz signals which is the transmitted frequency of the devices that are produced in European countries. In USA/Canada uses the frequency of 902 MHz and Japan 928 MHz. (EnOcean, [Ref. 29.01.2020]).

## **3.2 Beckhoff**

Beckhoff is now days one of the biggest, widely and generally known automation developers in the industry of automation. The company was founded in 1980s and since then Beckhoff has developed new and innovative PC-based products for automation industry. Many of automation standards that are taken granted even today were conceptualised by Beckhoff (Beckhoff 2015.)

Beckhoff products can be divided in 4 specific company categories

### **3.2.1 The IPC Company**

Industrial PC for every kind of applications. Strong construction with high-quality components guarantees the operability in different conditions. The PCs are developed for computing all types of automation processes. (Beckhoff 2015.)

### **3.2.2 The I/O Company**

Technology for all types of signal and fieldbus devises. Common fieldbus and I/O systems are supplied by a complete range of fieldbus components. Different types of bus terminals and fieldbus box modules for all important signal types and fieldbus systems. Modules, terminals and boxes for high-speed EtherNET fieldbus based on EtherCAT operations. (Beckhoff 2015.)

### **3.2.3 The Motion Company**

PC-based motion controllers for positioning from one to multiple axis offered by the TwinCAT automation software. Controlling servo systems with highly dynamic requires. Controlling servomotors via one cable which combines power and feedback system in a standard motor cable. (Beckhoff 2015.)

### 3.2.4 The Automation Company

Comprehensive system solutions in different performance classes for all areas of automation. TwinCAT-automation software integrates real-time control with PLC, NC (Numerical Control) and CNC (Computer Numerical Control) in single package. All Beckhoff controllers are programmed using TwinCAT in accordance with the globally recognised programming standards. (Beckhoff 2015.)

### 3.2.5 Beckhoff Master terminal KL6581

The master terminal for EnOcean module. A bidirectional terminal that can receive and transmit information data to actuators. KL6581 works as a master terminal in the radio signal communication network. The master terminal is a link between the Beckhoff KL6583\_1 transceiver where the EnOcean TCM 320 transceiver is attached to and receiver modules such as bus terminals or PLC equipped modules and an operating system (Beckhoff 2015.)

### 3.2.6 Beckhoff BK1120 Bus Coupler

Bus Coupler BK1120 is developed by Beckhoff. BK1120 is a separate I/O module which means that the BK1120 do not contain any type of PLC-controller inside like Beckhoff CX-versions. Bus Coupler (BK) recognizes all the connected bus terminals that are attached to the BK1120 bus coupler and then allocates the terminals automatically into the EtherCAT process image. (Beckhoff 2015.)

BK-Bus Couplers requires a controlling master PLC for use. A regular computer is suitable. EtherCAT connection does not require special plug-in connections for computer, basic network interface card with Ethernet-plug is suitable. In EtherCAT-network, the BK1120 Bus Coupler can be installed anywhere in the Ethernet signal transfer section, except directly at the switch. (Beckhoff 2015.)

**EtherCAT** (Ethernet Control Automation Technology) is a simple way to control industrial automation via Ethernet cable. EtherCAT offers very short cycle times and



low hardware costs. EtherCAT was originally developed by Beckhoff. EtherCAT is well suitable for small and medium applications. (Beckhoff. 2015.)

### **3.2.7 Beckhoff KL6583\_1**

KL6583\_1 works as a transceiver for behalf of Beckhoff devices where the EnOcean TCM 320 transceiver is attached to. Maximum amount of KL6583\_1 that are connected to KL6581 terminal is 8. KL6583\_1 is required for the data to move between EnOcean TCM 320 transceiver and KL6581 terminal. (Beckhoff 2019, 11 – 14.)

### **3.2.8 Beckhoff KL9010 End terminal**

End terminal is necessary when exchanging data between bus coupler and bus terminals. End terminal does not have any other functions or connection facility. (Beckhoff 2015.)

### **3.2.9 TwinCAT 3**

TwinCAT (The Windows Control and Automation Technology) is a software developed by Beckhoff in 1986. TwinCAT 3 is suitable for almost every PC-based automation system. TwinCAT 3 includes many different runtime systems (Beckhoff [Ref. 11.03.2020].)

## **3.3 ELTAKO**

Horst Ziegler was an engineer and the founder of a company that develops impulse switches, automated footlights, relays, light dimmers, energy meters and other kind of devices for wireless communication in German 1949. Zieglers Eltako has been a number one manufacturer in Europe in the equipment of this kind. Eltako comes from words “electrical pushbutton contact” which is “**Elektrischer TastKomtalt**” in

German language (Eltako, [Ref. 29.01.2020].) Most of the products is easily moveable and do not need specific educations for using or installing. Each product contains instructions for use and installing.

NOTICE. If the product is connected to mains current, then is a professional installed recommended.

### **3.3.1 FFT55Q-button**

A wireless flat push button approximately 10mm thick and is very similar looking with a regular electricity push button but it contains no place for wirings. Pressing down rocker from the marked area the button sends an electromagnetic signal from the button's antenna. The electromagnetic signal needs so little amount of energy to be transmitted that the mechanical instruction inside the button is capable to generate a needed amount of energy that a signal can be transmitted from the button. Buttons are used to control the electricity flow, for example in sockets that include a receiver for electromagnetic data signal to be received. A button can be used as a remote controller or it can be attached to a flat surface (Eltako Ref. [03.02.2020].)

### **3.3.2 FTKE-button**

The action in FTKE-button is basically the same as in the FFT5Q-button but the use is different. For monitoring wirelessly doors or windows state are they open or closed. No wire or no battery inside the FTKE-button. The button equipped with a lever is a good solution for motoring a door usage or sending an alarm signal if a window is opened. Because of the small size and simply conformation of the button it allows the button to be attached almost anywhere. Flat surface is recommended (Eltako Ref. [03.02.2020].)

### 3.3.3 FSVA and FSUD-socket

For controlling and measuring 230V voltage. Sockets with an increased shock protection. A hybrid socket that uses electromagnetic data signals to act and is capable to control the mains current through it. Sockets includes a receiver and the socket can transmit wireless data signals telegrams. Integrated current measurement is up to 10A current. FSUD-sockets functions are basically same as in FSVA-socket, but FSUD includes a function to adjust current flow through it. FSUD-socket can be used as a dimmer (Eltako Ref. [03.02.2020].)

### 3.4 Appurtenance

Each device uses the same method but can be use in different situations. Card switch PTM215 DB sends a data signal when card in set inside and a different signal when the card is pulled out. Secusignal window/door lever which send different signal protocol in different positions up, down or sideways. The lever can be set to send an alarm signal if a window is opened or left open. FWZ12 can be used for measuring current usage in different situations. FTK solar detector for monitor situation that includes sunlight. Manufacturers for wireless devices is encompassing so the assortment for different usages is also encompassing.



Figure 9 All data transmits through antenna

## 4 ENOCEAN RADIO PROTOCOL

The communication protocol is packed based and the data units can be of three different types. Frame, subtelegram or telegram. Telegram consist of subtelegrams and a subtelegram consist of frames. A frame comes in bit by bit sequences and constitutes a subtelegram. Subtelegram contains 4 sections and the sections are packed into a telegram (EnOcean 2013, 5.)

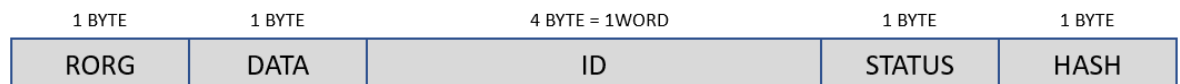

Figure 10 EnOcean signal protocol

Each section has 10 time slots of the size 1m/s. All the necessary data should arrive to the receiver in 40ms. The timing method aims to avoid telegram collisions from different transmitters. By timing each subtelegram can be outside signals avoided (EnOcean 2013, 6.) Figure 9 shows the order of the subtelegrams.

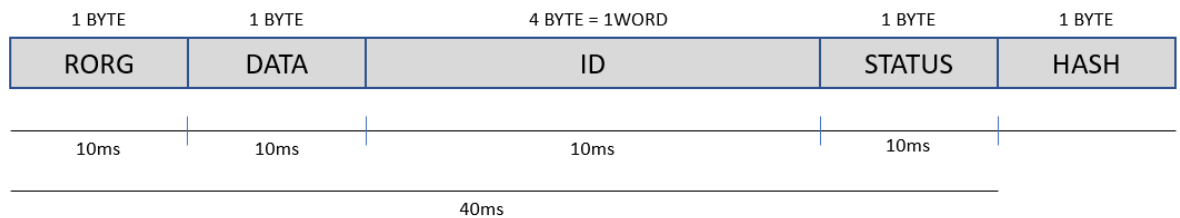

Figure 11 EnOcean signal protocol in timeline

Observe the figure 11. First 10ms will be ROGR data received which identifies the subtelegram type. In following 10ms data where the payload of the transmitted subtelegram will be defined. TXID will identify the transmitter, each having a unique 4-byte identity. STATUS identifies if the subtelegram is transmitted from a repeater and the type of integrity control mechanism used. This field is not present in a switch telegram. HASA is the data integrity check value of all the bytes. If HASA value does not match to expected value the protocol will be ignored or an error will arrive (EnOcean 2013, 5.)

## **5 INSTRUCTIONS FOR THE WORK**

### **5.1 Devices and data actions**

The project begins from planning what devices are necessary for sending, receiving, transmitting data and how to get all the devices to act in wanted ways by using the data in the transmitted electromagnetic waves. Two different types of switches are used in this project: kinetic buttons and switches that use solar energy. By pressing a button an electromagnetic wave can take its first move and a signal protocol will be received by the antenna. By using the received data, the program sends a separate signal and transmits the signal from a PLC to an antenna. All the data needs to be transmitted via antenna because the sockets are designed to communicate with outside signals even without a program. The data from buttons needs to be modified into other form in the program so that it follows direct terms for action.

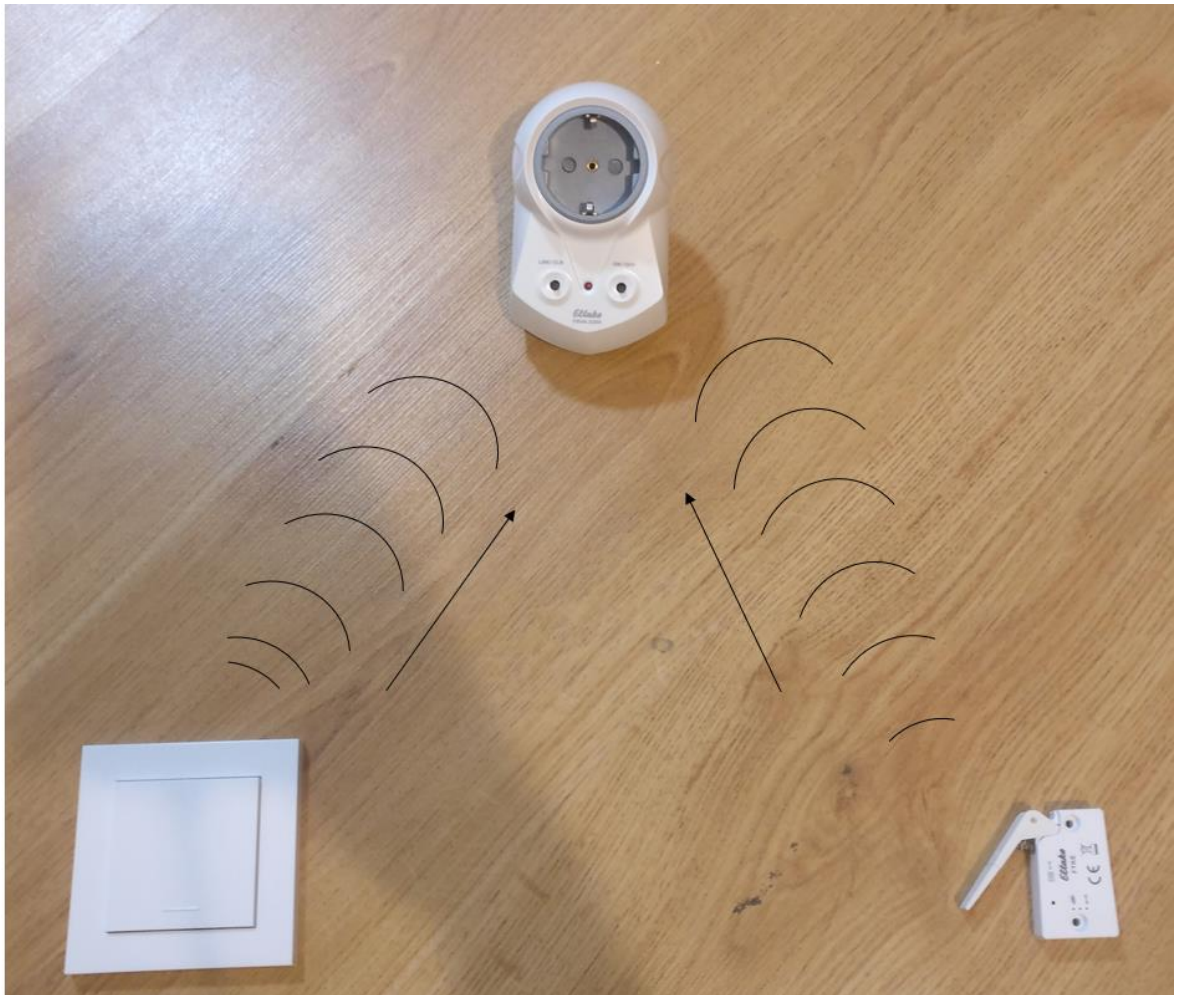

Figure 12 Signal leaves from buttons toward a socket

### 5.1.1 Receiving and transmitting information

Eltako sockets are designed to receive data signals and to change the state when a data signal is received. Buttons and sockets can be paired easily to each other without any outside software needed so the socket will change its state when a data signal from a button is received. Figure 12 shows how data signals are transmitted towards the socket. The idea of this project is that the operating system is programmed for controlling that the devices will follow certain actions. These are for example a lamp will light only if a key card is set. New devices can also be added to the configuration. It is necessary for the antenna to receive the signals from the control devices and transmit a modified signal to a controlled device. Instructions for pairing in section Pairing sockets.

EnOcean transceiver TCM320 is used for receiving signals from controlling devices and transmitting the modified signal to controlled devices.

Teaching buttons to a socket needs to happen also from a PLC, otherwise the buttons data will be directed straight to a socket and no terms for buttons actions cannot be set. Instructions for pairing in section 5.6 pairing sockets from a PLC.

### **5.1.2 From antenna to PLC**

The signal cannot be transmitted from an antenna to a PLC by a single cable. The antenna requires a terminal where it transmits the data. Beckhoff KL6581 master terminal is used as a gateway for the received data. The KL6581 is designed to understand the data that is transmitted from the antenna. The KL6581 terminal requires a bus coupler for transmitting the data from the terminal to PLC. Beckhoff BK1120 is used for transmitting the data from the terminal to the PLC via EtherNET-cable that is a connection cable for the PLC and to the BK1120 bus terminal. In this project a regular computer acts as a PLC. Beckhoff designed PLCs, for example CX-versions, can also be used.

All the devices apply with low voltage, so a transducer is also necessary for transduction from 230V voltage AC to 24V voltage DC that the devices will not break by the force of high voltage that comes from mains current.

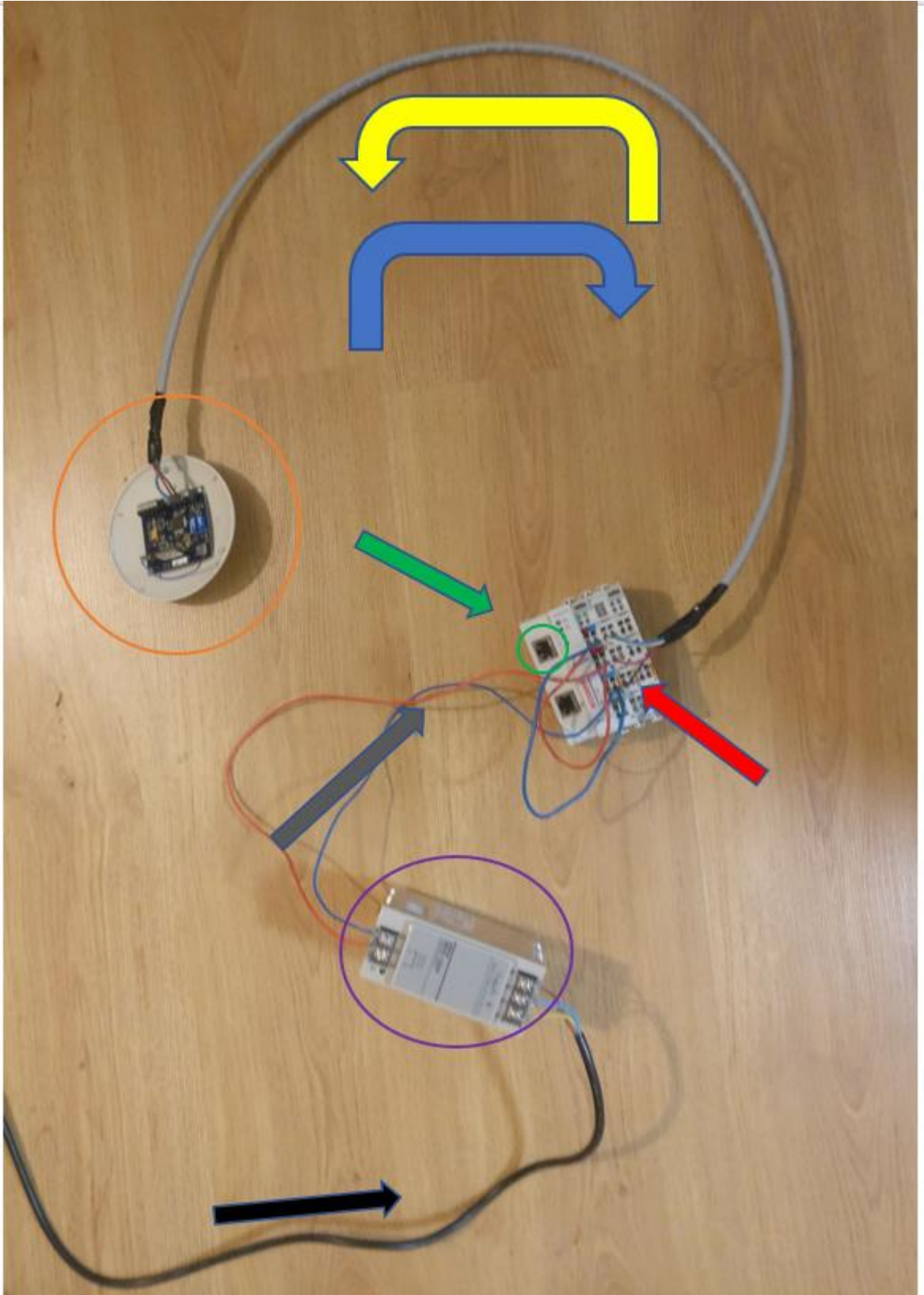

Figure 13 Components and information feedback



Observe figure 13. All the necessary sections that are required for receiving and transmitting data are defined in different shapes and colours. 230V voltage AC (black arrow) is the amount of voltage that is given from mains current. A transformer is marked with purple circle. Beckhoff devices and the EnOcean antenna applies with 24V voltage DC. The transformer is necessary for decreasing the voltage from 230V AC to 24V DC (grey arrow). Notice the currency change from AC current to DC current. Beckhoff BK1120 and an EtherCAT-plug (green arrow and green circle). The green arrow shows the bus coupler where all the devices for receiving and transmitting data are attached to. BK1120 is also connection between BK6581 and a PLC. EtherCAT-plug is the port for EtherNET cable that transmits data to a PLC and from a PLC (green circle). Beckhoff KL6581 (red arrow) is the bus terminal for the data that is received or transmitted. The data flow directions when receiving (blue) and transmitting (yellow). EnOcean TCM320 antenna is attached to Beckhoff KL6581\_1 actuator (orange circle).

## 5.2 Scanning devices and adding EnOcean library

When all the necessary devices have been installed and the EtherNET-cable is attached to a PLC the programming a software can be started. TwinCAT 3 is a programming software for Beckhoff modules and is used for programming the operating system. The project is built on TwinCAT XAE project (XML format).

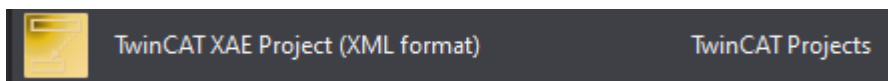

Figure 14 TwinCAT XAE Project (XML format)

The Beckhoff BK1120 and all the devices that are attached to the BK1120 are now connected to a PLC via EtherNET-cable. TwinCAT 3 is capable to locate all the connected devices and allocate the devices to a project image. The BK1120 does not include a PLC so TwinCAT 3 needs to know that a regular PC is used as a PLC by introducing all the real time compatible EtherNET devices to the TWINCAT 3 and installing the EtherNET connection. After introducing all the real time compatibles and installing the EtherNET driver can the devices be scanned into the TwinCAT 3-

software. By right clicking on Devices and selecting scan option all the devices will be successfully scanned and can be seen in solution explorer section (figure 15).

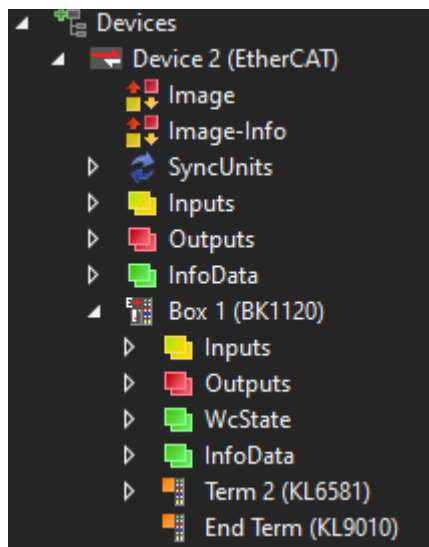

Figure 15 Scanned devices

The program can be written from zero by self but making the programming easier Beckhoff has created function blocks for users to control EnOcean devices. These function blocks can be found from TwinCAT 3 function block library (figure 16). After adding the Tc2\_EnOcean library to the references section the user has access for using EnOcean function blocks.



Figure 16 EnOcean library

### 5.3 Linking the master terminal and the master function block

The used data in the program is all that comes in and all that goes out. Beckhoff BK1120 is designed to transmit the input and output data via cable but for gathering

the data to the program as input and output data is a link between the physical KL6581 terminal and the digital function block KL6581 required. (Digital KL6581 can be seen in figure 19 and the explanation beneath it). Creating variables in the global variables section for the input data (stKL6581Input), a separate variable for the output data (stKL6581Output) and a third variable (stKL6581) that connects all the EnOcean function blocks to communicate with each other in the program. Global variables can be seen in figure 17.

```

VAR_GLOBAL
    stKL6581Input AT %I* : KL6581_Input;
    stKL6581Output AT %Q* : KL6581_Output;
    stKL6581 : STR_KL6581;
END_VAR

```

Figure 17 Global variables

After creating global variables and saving the project, an instance section will appear. Under instance section can be the input and output variables found that were created into the global variables section and introduced in figure 18. By creating the global variables, the input and output data can be used anywhere in the program and the variables requires to be linked manually to the transmitted data. Figure 19 shows where the linking can be done and the instructions for the linking are beneath it.

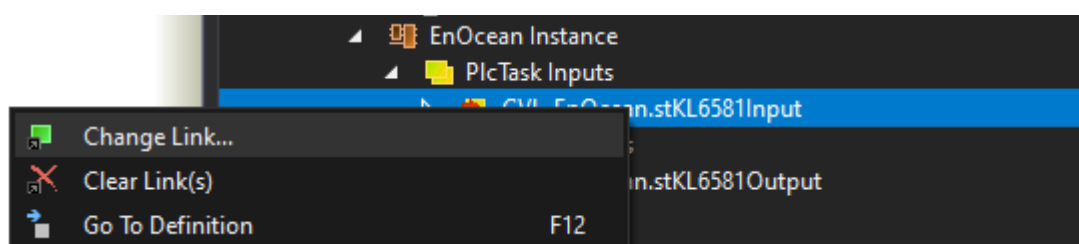

Figure 18 Change link

By changing the link to the scanned input and output variables from the physical KL6581 can be the linking done. TwinCAT 3 will automatically suggest the scanned input and outputs and the user has to manually choose the where the global variables are wanted to be linked.

The FB\_KL6581 function block cannot use data directly from the physical KL6581 so it is necessary to create the link between the global variables and the physical KL6581 data. Beckhoff offers function block FB\_KL6581 for communication with the physical KL6581 terminal. Data is exchanged via this function block (figure 19) and the program starts with the FB\_KL6581 function block.

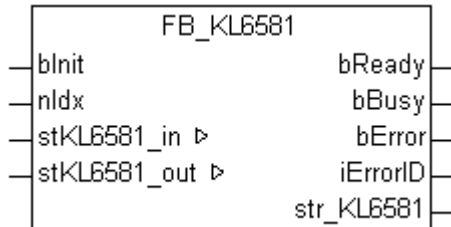

Figure 19 Digital KL\_6581 function block

FB\_KL6581 contains on the left side two in/outputs variables where data can go either in or out. The stKL6581\_in stores all the input data and the stKL6581 stores all the output data. The data is needed to go in and out so it can be used in other section of the program for the program to work properly. On the right side five outputs where data can go only out direction (more specifics about the function blocks variables in the 5.4.1 FB\_KL6581 function block).

## 5.4 Programming

After the linking is done, values of the input data signals from the devices can be received in the program and the programming can be started. All the EnOcean function blocks needs to be called in a same task so the main program needs to be created in continuous function chart (CFC). Subprograms can be created by using any Implementation language, but each subprogram requires to be called in the same task with the main program as a function block.

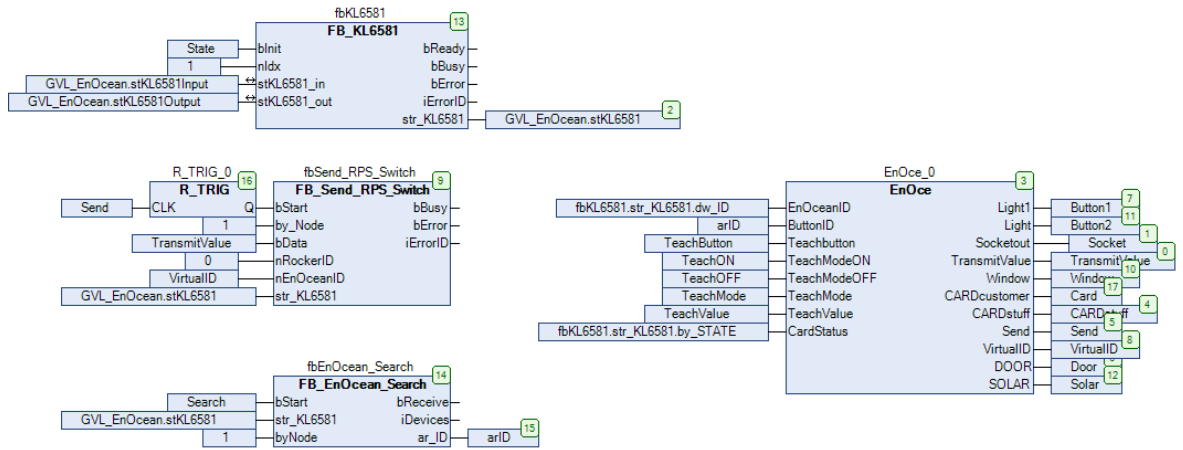

Figure 20 Main program (CFC)

In figure 20, EnOce-function block is written in structured text (ST) and is called in the main program as a function block. EnOce is created function block by user. The EnOce name is made-up and the name for the subprogram function block is given at the moment when it is created.

### 5.4.1 FB\_KL6581 function block

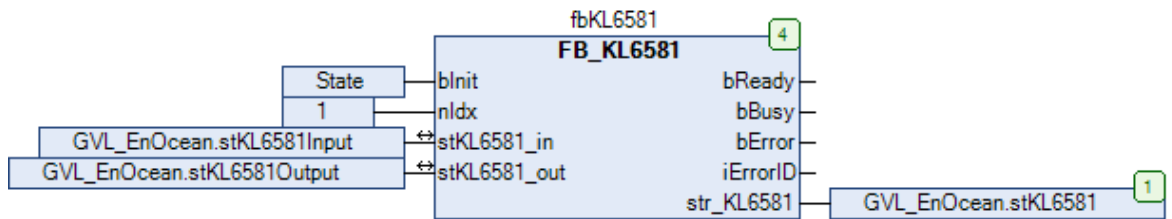

Figure 21 FB\_6581

All the principal variables crated in the global variables are linked to the master function block FB\_KL6581.

**State** defines that is the function block off- or on-mode. State variable is a BOOL variable and it can be either true or false (on/off).

**nIdx** needs to be unique for each KL6581 function block. It identifies the function block and separates the function block from others if there are others in use.

**stKL6581\_in** and **\_out** variables that are linked to input and output data coming from KL6581 master terminal.

**str\_KL6581** connected to GVL\_EnOcean.stKL6581 which is created in global variables section. It connects with all other function block and data moves in main program via GVL\_EnOcean.stKL6581

**bReady** is true when the function block is ready for sending and receiving data.

**bBusy** is true if the block is active.

**bError** shows the errors messages.

**iErrorID** shows the type of the error.

#### 5.4.2 FB\_Send\_RPS\_Switch function block

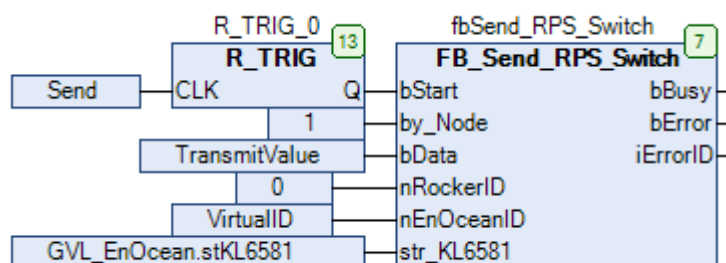

Figure 22 FB\_Send\_RPS\_Switch

For transmitting data from a PLC to an antenna the FB\_Send\_RPS\_Switch is necessary. The buttons can transmit data to a socket but if the socket or some other device have other requirements to go on or off, for example a keycard, then all data needs to be transmitted via the FB\_Send RPS\_Switch function block.

**bStart** sends the given data on a rising edge.

**by\_Node** defines the address of the antennas where the data is wanted to be transmitted. The address of the antenna can be seen from a dip switch on the BK6583\_1 actuator and the address can be set on values 1-8. Each antenna requires an individual address.

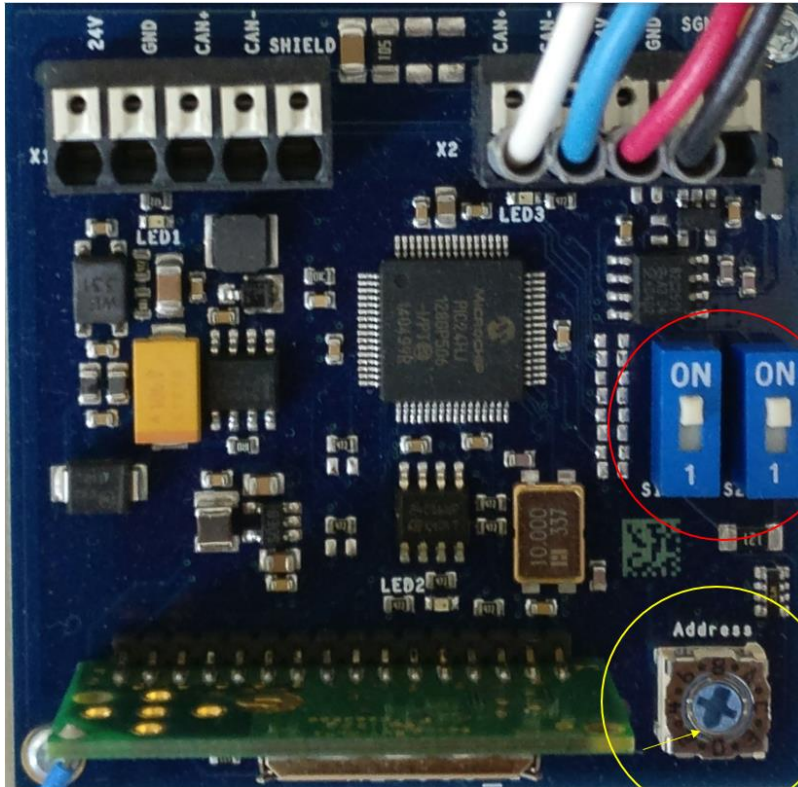

Figure 23 KL\_6583\_1 actuator

When using more than one antenna the last antenna that is connected to the KL6581 terminal requires both dip-switched set to ON position (red circle). The address (yellow circle) needs to be individual for each antenna and the (yellow arrow) points to the address number that it is set to. The available addresses are 1-8 (yellow circle) which can be seen in figure 23. For example, if an installation contains more than one antenna then the first antenna requires both dip switches set to 1 (red circle) and the address is set to 1 (yellow circle). The second antenna is installed to continue from the first antenna by using a cable and the dip switches are both set to ON in the first antenna because the second is then the last antenna and the address is set to 2 in the second antenna because the address needs to be individual for each antenna.

**bData** is either true or false. The transmitted output value can be modified by defining the value to be true or false.

**nRocketID** is the button number and allowable values are from 0 to 3.

**nEnOceanID** is the virtual EnOcean ID value. A valid value of 0 to 127 is added to the real EnOcean ID.

### 5.4.3 FB\_EnOcean\_Search

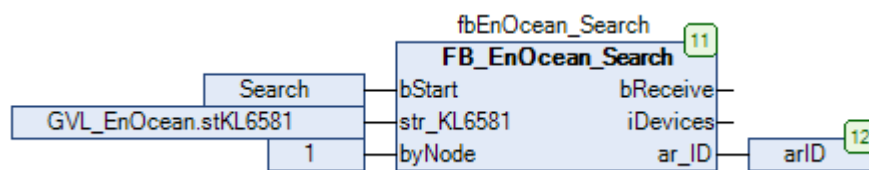

Figure 24 FB\_EnOcean\_Search

EnOcean\_Search function block is not necessary for the program to work. With EnOcean\_Search can be the id-address of each device memorized. In this program it is only used for counting how many devices are in use and introducing the id's in the visualization.

**bStart** activates the operation of the function block.

**str\_KL6581** connects the function block to the EnOcean operating system network.

**byNode** defines from which address of the antennas the data is received.

**ar\_ID** shows the latest id address of the device that is used.



## 5.5 Structured text EnOce

```

4 ButtonID : ARRAY [0..255] OF DWORD;
5 Teachbutton1 : BOOL;
6 TeachModeON : BOOL;
7 TeachModeOFF : BOOL;
8 TeachMode : BOOL;
9 TeachValue : BYTE;
10 END_VAR
11 VAR_OUTPUT
12     Light1 : BOOL;
13     Light : BOOL;
14     Socketout : BOOL;
15     TransmitValue : BOOL;
16     Window : BOOL;
17     CARDcustomer : BOOL;
18     CARDstuff : BOOL;
19     Send : BOOL;
20     VirtualID : RVTR;

```

---

```

1
2 OutputArray := MAIN.fbKL6581.str_KL6581.ar_DB;
3
4 // Button 1 is pressed.
5
6
7     ////////////////////////////////////////////BUTTON1////////////////////////////////////
8
9     IF OutputArray[3] = 16 AND EnOceanID = 4277838904 AND CARDcustomer = TRUE
10
11         THEN VirtualID := 10;
12             Light := TRUE;
13             TransmitValue := TRUE;
14
15         ELSE Light := FALSE;
16     END_IF
17
18     IF Light = TRUE THEN
19         Send := TRUE;
20     END_IF
21
22
23     IF OutputArray[3] = 16 AND EnOceanID = 4277838904 AND CARDcustomer = TRUE AND Socketout = TRUE
24
25         THEN VirtualID := 10;
26             Light := TRUE;
27             TransmitValue := FALSE;
28     END_IF

```

Figure 25 EnOce

EnOce is written by using structured text implementation language. All the processes for controlling devices actions are running in the EnOce function block by defining how devices act in different situations. In figure 25, the button 1 is pressed section includes all the necessary commands for the button to act in a wanted way using data that is gathered in the global variables.

The structured text is mostly written by using BOOL, BYTE and DWORD variables. For example, in figure 25 the first written lines. If BYTE variables value equals to 16 and EnOceanID variable value equals to DWORD and BOOL variable value is true, then the variables change the values that are pointed. In figure 25 TransmitValue changes its value from false to true.

|        |      |     |
|--------|------|-----|
| DB3    | BYTE | 16  |
| ID0    | BYTE | 77  |
| ID1    | BYTE | 164 |
| ID2    | BYTE | 250 |
| ID3    | BYTE | 254 |
| STATUS | BYTE | 32  |

Figure 26 Input value received by the antenna

Figure 26 shows how the input values can be seen when the antenna receives a data signal and these values are used in program to define each action. Values are unique from each device.

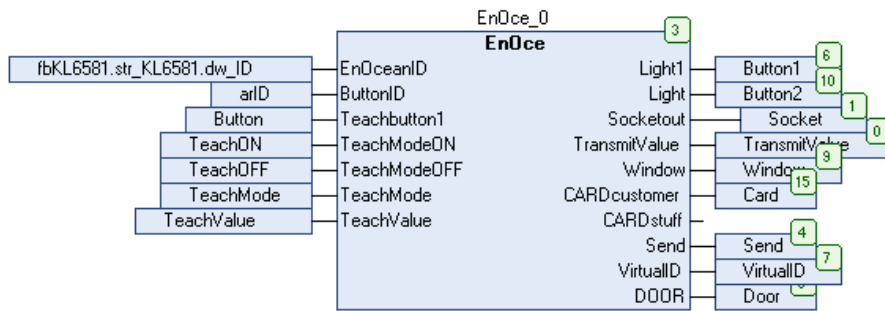

Figure 27 Structured text function block

Each input and output variables in the structured text that are wanted to be used in other section of the program than in a subprogram (EnOce) needs to be written in input variables or outputs in output variables so the variables can be used in the main program and in the visualization (More about Visualization in 5.6 Virtual apartment panel) . Figure 27 shows how the input and output variables are linked between the subprogram and the main program. The subprogram can contain variables that are used only in the subprogram but cannot be used outside the subprogram.

Defining the input or output variables in the subprogram is defined above the structured text section and the section can be seen in the figure 25. A subprogram can

be written by using different implementation languages and the main program can use more than 1 subprogram.

## 5.6 Virtual apartment panel

Processes usually requires a panel or a screen where the processes can be controlled or monitored remotely. TwinCAT 3 contains a visualization section that can be used to make the controlling and monitoring easier. Visualization can be added to the program by creating a new visualization in the solution explorer section under the VISUs file.

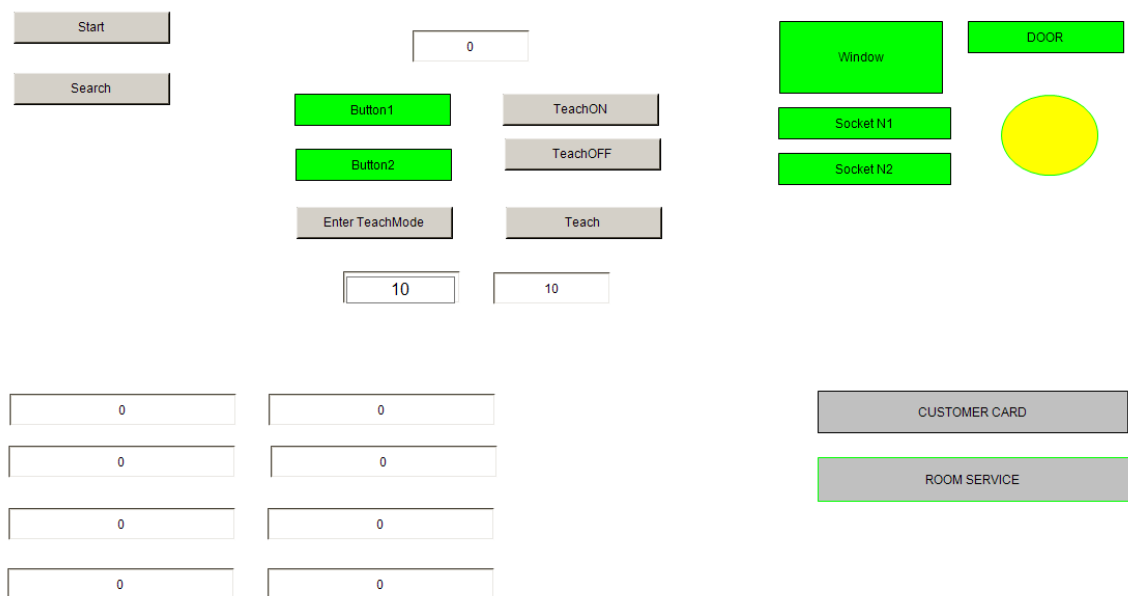

Figure 28 TwinCAT 3 visualization

Visualization contains lots of different options for controlling and monitoring. Options from regular buttons to adjustments and measurement meters. Explained options from figure 28: Controlling and monitoring devices shows what is devices current state, teaching buttons section and couple text fields that shows the device id's that are searched by using search function block.

Each used variable in the visualization requires to be introduced in the main program. Variables from the subprogram cannot be used in the visualization straight

from the subprogram. Each subprogram variable requires to be introduced in the main program and the figure 27 shows all the variables in the subprogram that are wanted to use outside the subprogram and how the variables are connected to the main program. For example, in figure 27: Light1 is a BOOL variable in the subprogram and is connected to output variable in the main program as BOOL variable button1. BOOL variable Button1 is then the variable that can be used in the visualization.

### **5.7 Adding new devices and modifying the program**

The program and the visualization are created for controlling and monitoring the process, but in a case of when new devices are wanted to add to the program. Every section is modifiable so new updates and changes for the program can be done, but the TwinCAT 3 needs to be changed to the configuration mode.

Points for adding a new device that are necessary to know. The id of the device and input/output variables that changes its state when the device is transmitting data signals. Other received input values can also be used but it is not necessary in this type of program. By using the received variable values and modifying the existing structured text or adding a new subprogram to the program where the new devices variables follow the wanted actions.

New devices may need new variables for use in the visualization or in the main program outside the structured text subprogram. The EnOce function block can be updated and if input or output variables are added to the right variables section the EnOce function block will automatically add the new inputs and outputs when the subprogram function block is updated. After each modification made to the program the program needs to be configured. This can be done at TwinCAT – Activate configuration.

## 5.8 Paring sockets from PLC

When clearing the socket from all taught telegrams hold LRN/CLR button for approximately 3 seconds so that the led starts flashing at a fast rate. Then press the ON/OFF button for approximately 5s until the led turns off.

When teaching a socket for a button press the LRN/CRL for 0.5 seconds and the LED lights up. Then press the ON/OFF button once and the socket is in a learning state. Press a wanted button and the paring is complete.

Paring sockets from PLC that the user can define terms for the actions how the device act in a certain situation. The data needs to be transmitted from the Send\_RPS\_Switch and the data value is given in nEnOceanID. The bData value in the Send\_RPS\_Switch defines the state of the transmitted data and separates two different states of the transmitted data without changing the nEnOceanID value. For example, the input value for a button's nEnOceanID is 10 and the bData is true and the socket is taught to go on when these values are transmitted. If the nEnOceanID is 10 and the bData is false, the socket is taught to go off.

Sockets are set to a configuration mode by pressing the LRN/CLR button in the socket for half a second and then release. Pressing the ON/OFF button three times after the socket is set to the configuration mode the socket goes in a teaching mode to go on-state and the next received data signal will set the socket to go on every time the socket receives the same data signal (the same data signal will not turn the socket off). Pressing the LRN/CLR for half a second and release the socket goes back to the configuration mode. Pressing the ON/OFF four times, the socket is in teaching mode to go off-state by the next received data signal. Both on and off data signals need to be transmitted from the Send\_RPS\_Switch when the socket is in a teaching mode. The transmitted data from Send\_RPS\_Switch needs to be individual and the data can be individualized by changing the transmitted BOOL value in the Send\_RPS\_Switch to be true or false.

## 5.9 Apartment layout

Figure 29 shows an apartment where the wireless communication devices have been installed. The antenna has been installed in the center of the apartment. As the antenna cannot generate power, it needs to be at least in range of 500m from the KL6581 terminal. The distance is the suggested length for the connection cable between the antenna and the KL6581 terminal so the signal will not be distributed by the too long distance. The length of the cable can change the amount of the current in the cable and is then received in different form by the antenna and the signal will be rejected. Each device that is capable to send data by using kinetic electricity can be attached or set to any location provided that the antenna is in the communication range. The communicating range is specified by the amount of object and the recommended range in clear distance is approximately 30m. If a device is wanted to be used at such a long distance that the data signal cannot reach the antenna or if there are materials that do not let the signals through, it is necessary to install a second antenna that can be used as a transmitter to the other antenna.

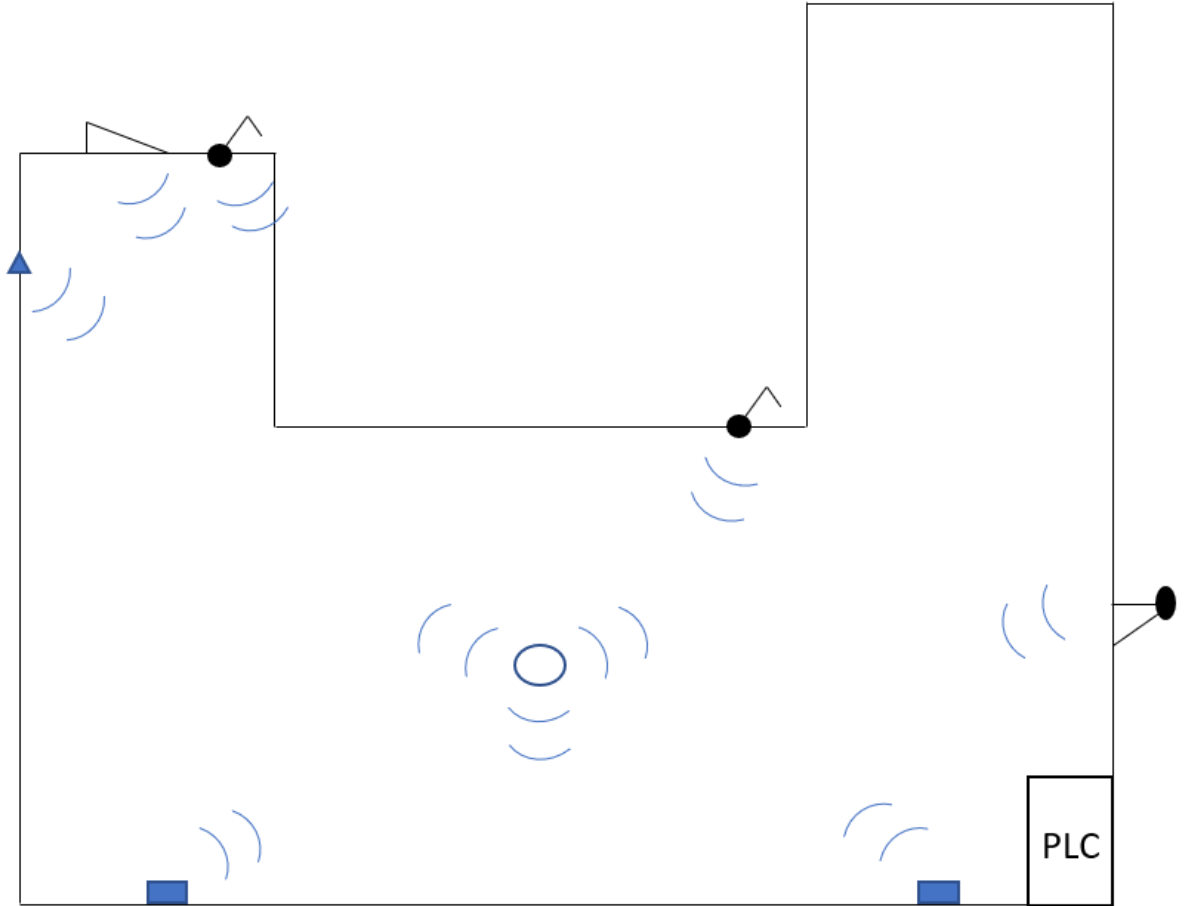

Figure 29 Apartment layout

Figure 30 describes a situation where the data signal cannot get through a certain material. In this kind of situations or in situations where the antenna is too far, a second transmitting antenna is necessary.

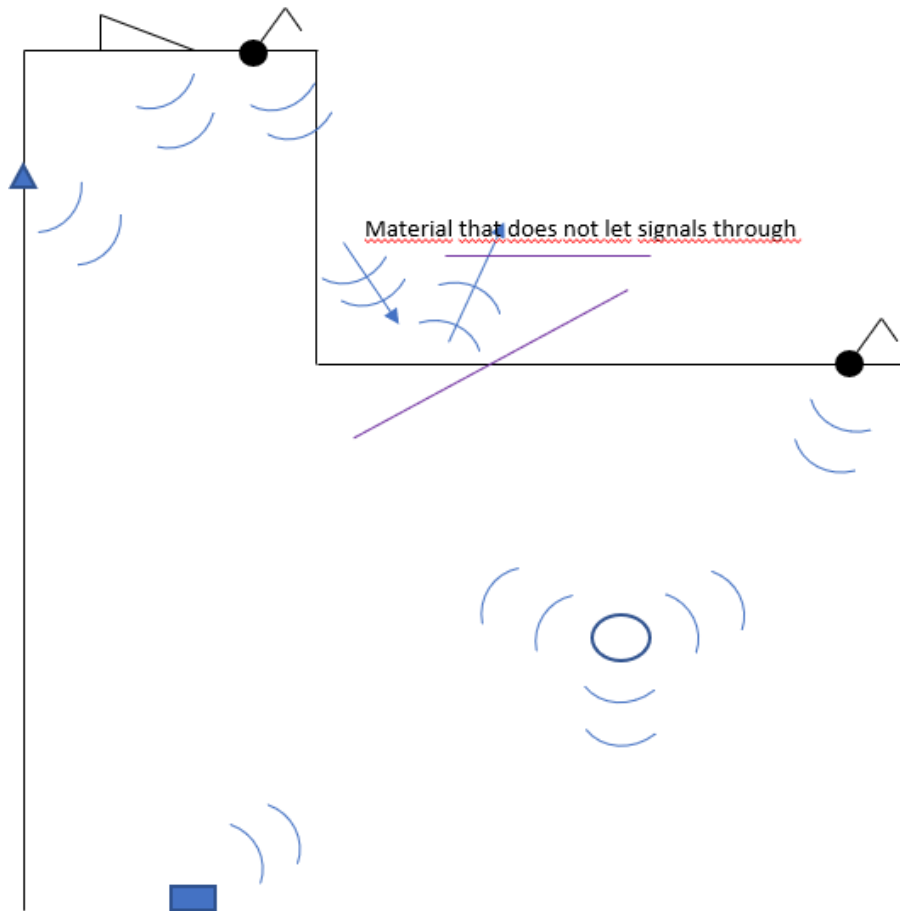

Figure 30 Data signal cannot get through

Figure 31 shows a situation when signal rejecting material is between a device and the antenna. The second antenna is installed in a location where the signal can go around the rejecting material. It is important to remember that each antenna requires an individual address and the last antenna needs to be set on the last antennas configurations.

Designing places for devices with no wire is easy and does not need hard wire installations. In a situation where an apartment is sold and the next resident does not like the location where a button is attached, it is easy to just remove the button and set it to a location where the next resident desires. No modifications in the program is needed when changing the locations of the devices unless the locations require more antennas.



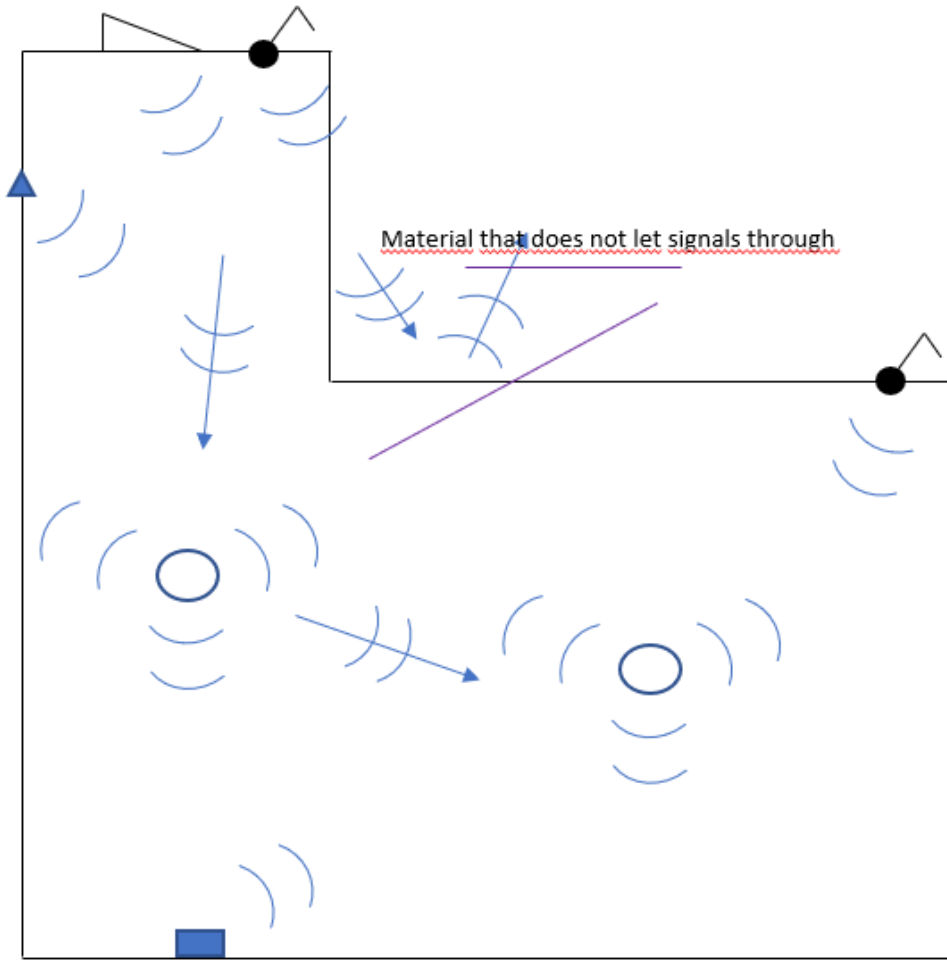

Figure 31 Second transmitting antenna

## **6 RESULTS AND SUMMARY**

### **6.1 Results**

The result of the thesis was successful. By following the instructions given for each device and program section a practical smart apartment was completed. The things that made this work difficult were the total amount of devices and the little sections in instructions that were inadvertently missed and thus caused problems from actions. Understanding each section in programming and how to use input data for programming was difficult because computers can understand just the right form in how the data can be received or transmitted in each section of the program. How to use the input data from devices to channel the output values in the program in a correct form so the input data can be used to transmit a certain output data.

A smart apartment was accomplished where a socket cannot be used unless a key card is set into a detector. The key card method is similar with the design of a hotel room. The state of a door can be monitored and if a window is left open when the key card is pulled out and an alarm will arrive on the monitor. The state of a window cannot be seen when the key card is set into the detector so no alarm will arrive if someone is in the apartment. Even a solar detector was added to the program with no official use purpose. The key card detector will recognize if a staff member's card is set in the detector. Sockets will automatically turn off if a key card is pulled off when the socket is left on. A device that measures current was excluded from the program.

### **6.2 Summary**

The project taught me a lot about electromagnetic waves. How the waves act and how they can be modified for devices in readable forms and how the devices are able to transmit electromagnetic waves. During the thesis project my programming skill got a lot better and learning about data usage in devices gave a better understanding of how new technology works and thus it is easier to understand certain

actions in electronic devices. The program and thesis will hopefully guide and offer many different practices for the next generation students.

## REFERENCES

- Beckhoff. BK1120 | EtherCAT Bus Coupler. [www-document]. Beckhoff. [Ref. 29.01.2020]. Available at <https://www.beckhoff.com/BK1120/>
- Beckhoff. Beckhoff short profile. [pdf-document]. Beckhoff. [Ref. 29.01.2020]. Available at [https://www.download.beckhoff.com/download/press/Short\\_profile\\_Beckhoff.pdf](https://www.download.beckhoff.com/download/press/Short_profile_Beckhoff.pdf)
- Beckhoff. eXtended Automation (XA 2019 | TwinCAT 3). [www-document]. Beckhoff. [Ref 11.02.2020]. Available at <https://beckhoff.com/Twincat3/>
- Beckhoff. KL6581 | EnOcean master terminal. [www-document]. Beckhoff. [Ref. 29.01.2020]. Available at <https://www.Beckhoff.com/KL6581/>
- Beckhoff. KL6581 and KL6583 EnOcean Bus Terminal and Transceivers. [pdf-document]. Beckhoff. Available at [https://download.beckhoff.com/download/Document/io/bus-terminals/kl6581\\_kl6583en.pdf](https://download.beckhoff.com/download/Document/io/bus-terminals/kl6581_kl6583en.pdf)
- Eltako ELECTRONICS. [pdf-document]. Socket universal dimmer switch FSUD-230V. [Ref. 11.03.2020]. Available at [https://eltako.com/fileadmin/downloads/en/\\_bedienung/FSUD-230V\\_30100002-1\\_gb.pdf](https://eltako.com/fileadmin/downloads/en/_bedienung/FSUD-230V_30100002-1_gb.pdf)
- Eltako. Innovation by tradition: A company with a history and a future. [www-document]. Eltako Electronics. [Ref. 03.02.2020]. Available at <https://eltako.com/en/enterprise/about-us.html>
- Eltako. Wireless actuator. [pdf-document]. Eltako Electronics. [Ref. 03.02.2020]. Available at [https://eltako.com/fileadmin/downloads/en/\\_bedienung/FSVA-230V\\_30100003-2\\_gb.pdf](https://eltako.com/fileadmin/downloads/en/_bedienung/FSVA-230V_30100003-2_gb.pdf)
- Eltako. Wireless Sensors – Flat Pushbuttons without battery or wire FFT55Q. [pdf-document]. Eltako Electronics. [Ref. 03.02.2020]. Available at [https://eltako.com/uploads/media/Wireless\\_datasheet FFT55Q.pdf](https://eltako.com/uploads/media/Wireless_datasheet FFT55Q.pdf)
- EnOcean alliance. WIRELESS WINDOW/DOOR CONTACT WITH ENERGY GENERATOR FTKE-RW. [www-document]. EnOcean Alliance. [Ref. 03.02.2020]. Available at [https://enocean-alliance.org/product/eltako\\_sensor\\_with\\_energy\\_generator\\_ftke/](https://enocean-alliance.org/product/eltako_sensor_with_energy_generator_ftke/)
- EnOcean. About us. [www-document]. EnOcean GmbH. [Ref. 29.01.2020]. Available at <https://www.enocean.com/en/about-us/company-profile/>

- EnOcean. EnOcean Radio Protocol 1. [pdf-document]. System Specification on Hardware. [Ref. 19.02.2020]. Available at <https://enocean.com/en/support/knowledge-base/>
- EnOcean. TCM 320. [www-document]. EnOcean GmbH. [Ref. 29.01.2020]. Available at [https://www.enocean.com/en/products/enocean\\_modules/tcm-320/](https://www.enocean.com/en/products/enocean_modules/tcm-320/)
- Hakala, M. & Vainio, M. 2005. Tietoverkon rakentaminen. Porvoo: WS Bookwell
- Launiainen, P. 2019. Värähtelevä maailma. Tallinna: Raamatutrükikoja OÜ
- Lehto, A. 2006. Radioaaltojen maailma. Tampere: Tammer-Paino
- NASA. Gamma Rays. [www-document]. NASA SCIENCE. [Ref. 05.02.2020]. Available at [https://science.nasa.gov/ems/12\\_gammarays](https://science.nasa.gov/ems/12_gammarays)
- NASA. Infrared Waves. [www-document]. NASA SCIENCE. [Ref. 05.02.2020]. Available at [https://science.nasa.gov/ems/07\\_infraredwaves](https://science.nasa.gov/ems/07_infraredwaves)
- NASA. Introduction to Electromagnetic Spectrum. [www-document]. NASA. [Ref. 05.02.2020]. Available at <https://nasa.gov/directorates/hea/scan/spectrum/overview/index.html>
- NASA. Microwaves. [www-document]. NASA SCIENCE. [Ref. 24.03.2020]. Available at [https://science.nasa.gov/ems/06\\_microwaves](https://science.nasa.gov/ems/06_microwaves)
- NASA. Radio Waves. [www-document]. NASA SCIENCE. [Ref. 24.03.2020]. Available at [https://science.nasa.gov/ems/05\\_radiowaves](https://science.nasa.gov/ems/05_radiowaves)
- NASA. Tour of the electromagnetic Spectrum. [www-document]. NASA. [Ref. 31.01.2020]. Available at [https://science.nasa.gov/ems/02\\_anatomy](https://science.nasa.gov/ems/02_anatomy)
- NASA. Ultraviolet Waves. [www-document]. NASA SCIENCE. [Ref. 05.02.2020]. Available at [https://science.nasa.gov/ems/10\\_ultravioletwaves](https://science.nasa.gov/ems/10_ultravioletwaves)



