

Saimaa University of Applied Sciences
Technology, Lappeenranta
Double Degree Programme in Civil and Construction Engineering

Viunov Valerii

COMPARISON OF SCAFFOLDING SYSTEMS IN FINLAND AND IN RUSSIA

Bachelor's Thesis 2011

ABSTRACT

Valerii Viunov

Comparison of Scaffolding Systems in Finland and in Russia,

66 pages, 5 appendices

Saimaa University of Applied Sciences, Lappeenranta

Technology, Double Degree Programme in Civil and Construction Engineering

Bachelor's Thesis 2011

Tutors: Petri Vauhkonen, Kirsi Taivalantti, Pekka Roitto

The purpose of this work was to study the present situation with scaffolding in Finland and in Russia in order to reveal differences between the systems themselves, to compare the regulations applied to scaffolding in both countries, and of course, to consider the competitiveness of European systems in Russia.

The best Russian scaffolding products were chosen and compared with German scaffolding, which is in common use in Finland.

Some information provided in this study is unique since the huge part of images and materials was obtained during the direct conversation with manufacturer's representatives.

Russian legislation system, being constantly subjected to changes, is not novice-friendly. It took plenty of time to distinguish, which of the documents are in their power and have to be followed. During the process of studying them it was important to check all the time that they do not contradict each other.

Necessary documents that must be prepared and taken care of during the process of scaffolding assemblage and use were defined, being sometimes a confusing task for even the professionals in the field.

Comparison clearly showed that Russian scaffolding systems have not reached the European level yet and this mostly comes from the demand. Building companies are usually interested in the cheapest offers possible.

Although the prices of foreign scaffolding systems are much higher, the advantages of higher-quality products are slowly becoming to be realized. The expansion of high-quality systems will definitely push Russian manufacturers to improve their products. And this study showed that the development is already noticeable. Some manufacturers are trying to improve their systems, bringing innovative ideas to design of their joints or to production process.

And from the work safety point of view it is definitely the step forward, because scaffolding itself ever stays to be a business of a very high risk.

Keywords: scaffolding, modular system, mobile scaffolding, fabricated frame, tube-and-coupler, handover certificate, work safety.

CONTENTS

1	INTRODUCTION	5
2	FUNDAMENTALS OF MODERN DAY SCAFFOLDING	6
3	BASIC SCAFFOLDING TERMS	11
4	MAIN TYPES OF SCAFFOLDING SYSTEMS.....	13
4.1	Modular scaffolding	13
4.1.1	Introduction to modular scaffolding	13
4.1.2	Cup-Lock modular scaffolding system.....	14
4.1.3	Ring-Lock modular scaffolding system.....	15
4.2	Tube-and-Coupler scaffolding	18
4.3	Fabricated frame scaffolding	20
4.4	Mobile scaffolding	22
5	MAIN RUSSIAN MANUFACTURERS OF MODULAR SCAFFOLDING SYSTEMS	24
5.1	RINSTROY Ltd.....	24
5.2	MDN-Prom Ltd.	27
5.3	Monolit Stroy Komplekt Ltd. (MSK)	30
5.4	SIMAN+ Ltd.....	31
6	COMPARATIVE ANALYSIS OF RUSSIAN RING-LOCK SCAFFOLDING SYSTEMS	35
7	COMPARISON OF RUSSIAN SCAFFOLDING SYSTEMS WITH THE ONES COMMONLY USED IN FINLAND	39
8	RUSSIAN REGULATORY DEMANDS FOR SCAFFOLDING	43
8.1	Introduction to Russian standardization system	43
8.2	Documents to carry about when performing assembly of scaffolding ..	46
8.3	Demands applied to scaffolding	48
9	COMPARISON OF RUSSIAN AND FINNISH SAFETY REQUIREMENTS FOR SCAFFOLDING.....	54
10	WORK SAFETY IN PRACTICE	58
11	SUMMARY	61
12	FIGURES.....	63
13	TABLES.....	65
14	REFERENCES	66

APPENDICES

Appendix 1 Russian scaffolding assembly and use poster

Appendix 2 Scaffolding handover certificate

Appendix 3 Journal of acceptance and visual examination of scaffolding

Appendix 4 Work site safety walk-around report

Appendix 5 Job titles on Russian building sites

1 INTRODUCTION

Scaffolding is a temporary structure used to support people and material in the construction or repair of buildings and other large objects. Commonly being high-raised means that work safety becomes the main thing to take care about.

Manufacturers all over the world are challenged to create the systems, which are versatile, safe, long-lasting and fast to assemble. They are trying to find the balance between the price and the quality. The most popular European scaffolding manufacturers are located in Germany. Their systems are widely used in Finland since they proved to be safe and meet the strictest demands of complicated construction projects.

If we take Russia, the situation is different. The country has her own manufacturers of scaffolding systems and foreign ones are very seldom can be spotted on Russian building sites. Although, during the last few years, some European companies started their business in Russia and brought new scaffolding systems to the country's huge market.

The present study is devoted to finding the advantages and disadvantages of Russian-made scaffolding and comparing it with European analogues. To perform it, the modular scaffolding was chosen as being nowadays the most advanced system on the world market.

In addition to scaffolding material itself, the comparison was made between Finnish and Russian legislation that deals with scaffolding and work safety at heights, being the valuable information for ones who plan starting business in Russia. Great attention was paid to description of present situation with Russian regulation system as well as to explanation of different normative documents and certificates.

2 FUNDAMENTALS OF MODERN DAY SCAFFOLDING

Scaffolding has been used ever since man began making buildings more than one storey high and needed to find a practical way of working at height. Although the materials and designs have changed over the centuries, the purpose of scaffolding remains the same – to provide a safe, temporary platform from which all types of construction, repair and maintenance work can be carried out.

There are different types of scaffolding, but usually they are all made up of the same basic components: tubes and boards. What actually varies much is the way of connecting the tubes together. In so-called tube-and-clamp system tubes are attached to each other by special couplers. Fabricated frame system provides the ready-made frames, which only need to be braced to ensure the rigidity of the whole system. The most up-to-date modular systems feature special joints that simplify the assembly process. They also provide the rigidity of the joints in addition to high versatility of the whole system. Modular scaffolding can reach great heights, retracing the complex shape of structure. Below is the Figure 1 showing the renovation of Landwasser Viaduct in Switzerland, during which the modular scaffolding was used.



Figure 1 Modular scaffolding - renovation of the Landwasser Viaduct in Switzerland

Scaffolding mainly consists of tubes. Tubes for scaffolding nowadays are either steel or aluminium. If steel they are usually painted or galvanized. Figure 2 illustrates the variety of materials, commonly used for scaffolding structures.

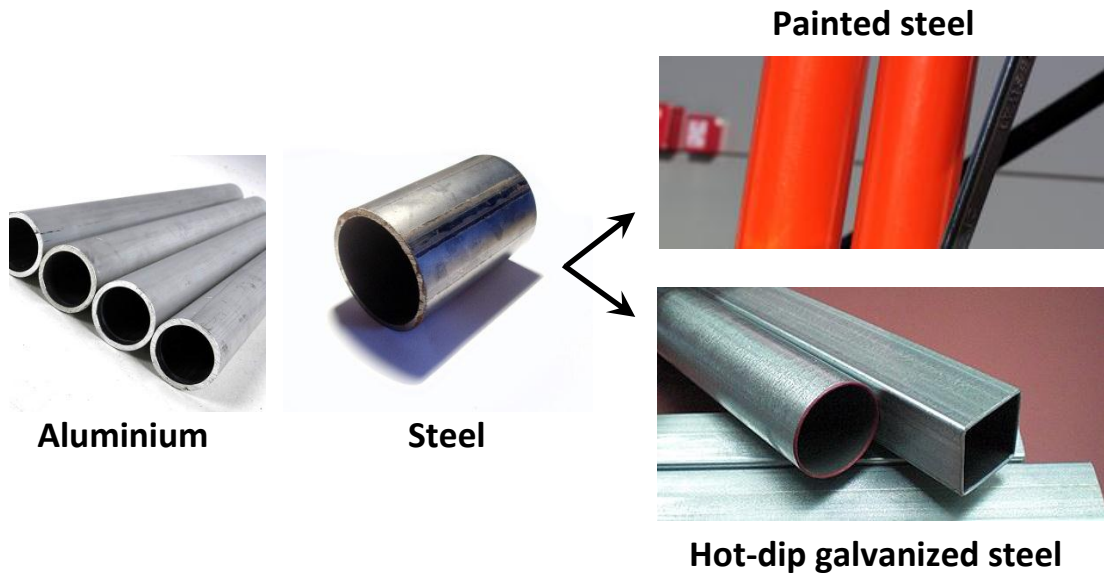

Figure 2 Scheme of scaffolding materials and their treatment

Galvanization originally refers to any of several electrochemical processes named after the Italian scientist Luigi Galvani. These processes are used to add a thin layer of another metal to a ferrous substrate, in order to prevent rusting. Though, the term has been widened in common usage to include applying a protective zinc layer to a piece of metal, using a process called **Hot-dip galvanizing**, which does not employ electrochemical deposition. It is done by passing the metal through a molten bath of zinc at temperatures around 460 °C. This is a usual way to treat scaffolding tubes. The practical difference is that hot dip zinc galvanizing produces a much thicker, durable coating, whereas genuine galvanizing produces a very thin coating. The thin coating produced by is much more quickly consumed, after which corrosion turns to the steel itself. This makes genuine galvanizing unsuitable for outdoor applications like scaffolding.

Visually it is possible to determine which process has been used: genuine galvanizing produces a nice, shiny surface, whereas hot dip zinc coating produces a matte, grey surface. But usually, when talking about scaffolding and mentioning the galvanized finish it is meant that its tubes are hot-dip galvanized.

Galvanized tubes are more expensive than painted ones, but they last much longer. Figure 3 shows two cases of scratching the protective coating. In the first case it is zinc coating and in the second the metal surface is painted.

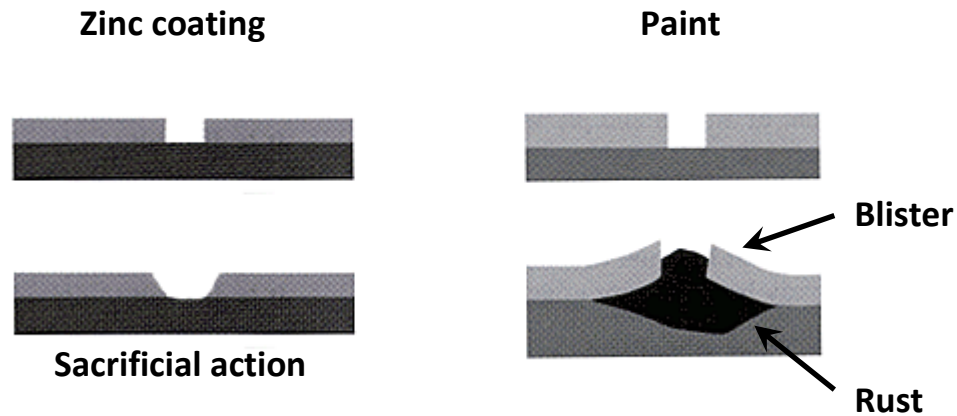

Figure 3 Scratch consequences on zinc-coated and painted metal pieces

The reason for the extensive use of hot-dip galvanizing is the two-fold protective nature of the coating. As a barrier coating it provides a tough, metallurgically-bonded zinc coating that completely covers the steel surface and seals the steel from the corrosion action of the environment. Additionally, the sacrificial action of zinc protects the steel even when damage occurs in the coating (Levy 2000, p.213). Zinc is more active metal, which have a greater tendency to lose electrons than less active steel. When zinc and steel are connected in the presence of the electrolyte (rain water), the zinc is slowly consumed, while the steel is protected. Zinc offers enough protection in small exposed areas such as scratches or drill holes. It is a great way to prolong the life of the element.

An item which is only painted will rust if scratched. The exposed steel corrodes and forms a rust pocket. Because rust has greater volume than steel, the pocket swells. This lifts a paint film from the metal surface to form a blister. Both the corrosion pocket with rust and the blister continue to grow.

One more important thing to mention is that it is quite complicated process to paint the tube from the inside. That is why for scaffolding only outer surface is painted. But with hot-dip galvanizing things are different. When the tube is passed through the molten bath of zinc the coating is applied to every surface –

outer and inner as well. That is the one more advantage of galvanized scaffolding tubes.

Another scaffolding material that should be mentioned is Bamboo. It has been used throughout history and survived over generations. In Asia today people still practice the traditional bamboo scaffolding. Workers build frames which are durable enough to support the weight of themselves, their equipment and materials while they work. It is a common sight in Asia to see these bamboo structures spanning the entire height of buildings and office blocks (Find Scaffolding website, 2011). On Figure 4 there are two photos taken in Hong Kong showing how high and complicated can be the bamboo scaffolding.



Figure 4 Bamboo high-rise scaffolding in Hong Kong, China

As bamboo is a light, portable material it is easy to move from site to site. This light weight and surprising durability means that no machinery is needed to assemble the scaffold and put it in place. The main thing about bamboo scaffolding is that safety and effectiveness of the bamboo scaffolds depends primarily on skill of workers. The knowledge is passed down to younger workers through an apprenticeship system and on-the-job learning.

Scaffolding is usually subjected to a wide range of loading during assemblage, use and dismantling. It should support its own dead load, live loads from construction materials, workers and tools, dynamic loads from material placement and wind loads.

When failures occur, large areas of scaffolding can suddenly collapse. Scaffolds can collapse because of poor construction or misuse leading to them being loaded beyond their safe capacity to support the load. Scaffolding stability depends on carefully following the manufacturer's instructions and national regulations. And also rough weather conditions can damage the scaffolding quite severe. Figure 5 shows the scaffolding failure in San Francisco caused by unforeseen heavy winds.



Figure 5 Scaffolding failure in San Francisco caused by stormy winds

Dismantling is the most difficult and hazardous operation in scaffolding business. The work should be planned carefully so that the scaffolding remains stable, workers are prevented from falling from the scaffold and others are protected from the risk of falling materials. Dismantling can place large loads on the scaffold unless the work is planned to keep the amount of material stored on the scaffolding to a minimum. Sometimes it should be additionally strengthened and stabilized by providing extra elements (Health and Safety Authority of Ireland 2008, p. 78).

Scaffolding has a variety of applications. It offers a safer and more comfortable work arrangement compared to leaning over edges, stretching overhead and working from ladders. Properly assembled and maintained, scaffolding provides workers safe access to work locations, stable working platforms, and temporary storage for tools and materials for performing immediate tasks (N.C. Department of Labor. Occupational Safety and Health Division 2008, p. 1).

3 BASIC SCAFFOLDING TERMS

The key elements of the scaffolding are standards, ledgers and transoms. **The standards** are the vertical tubes that transfer the entire mass of the scaffolding to the ground where they rest on a **base plate** to spread the load. Usually instead of the simple base plate there is an adjustable **base jack** to level the scaffolding on uneven surface. **Ledgers (Runners)** are horizontal members in the direction of the larger dimension of scaffolding. **Transoms (Bearers)** are horizontal members in the direction of smaller dimension. They usually provide the support for decks and sometimes called bearers. **Diagonal braces** bring rigidity to the scaffolding structure. All these main elements are shown on Figure 6 below.

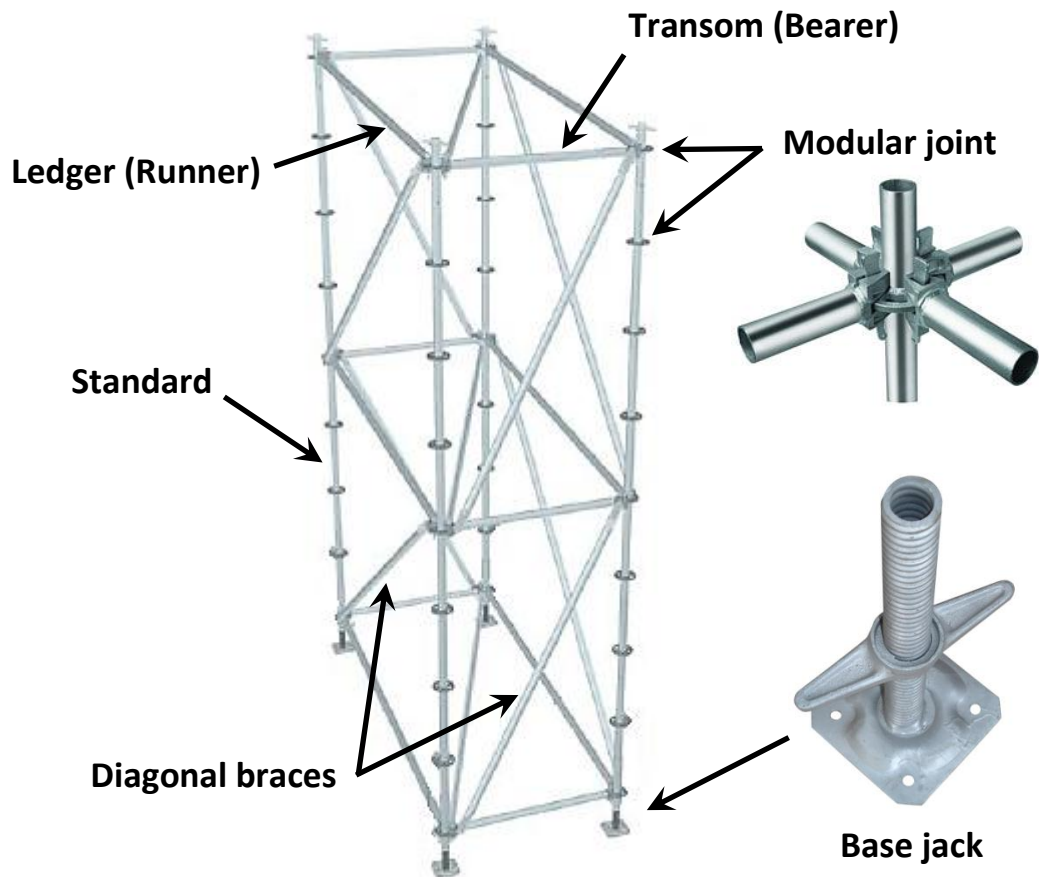

Figure 6 Main elements of scaffolding

On the image above the modular Ring-Lock joint is presented. The joints used to attach the tubes together vary greatly between different types of scaffolding. They will be described in detail further.

Basic scaffold dimensioning terms are explained on Figure 7. No decks, bracing or joints shown.

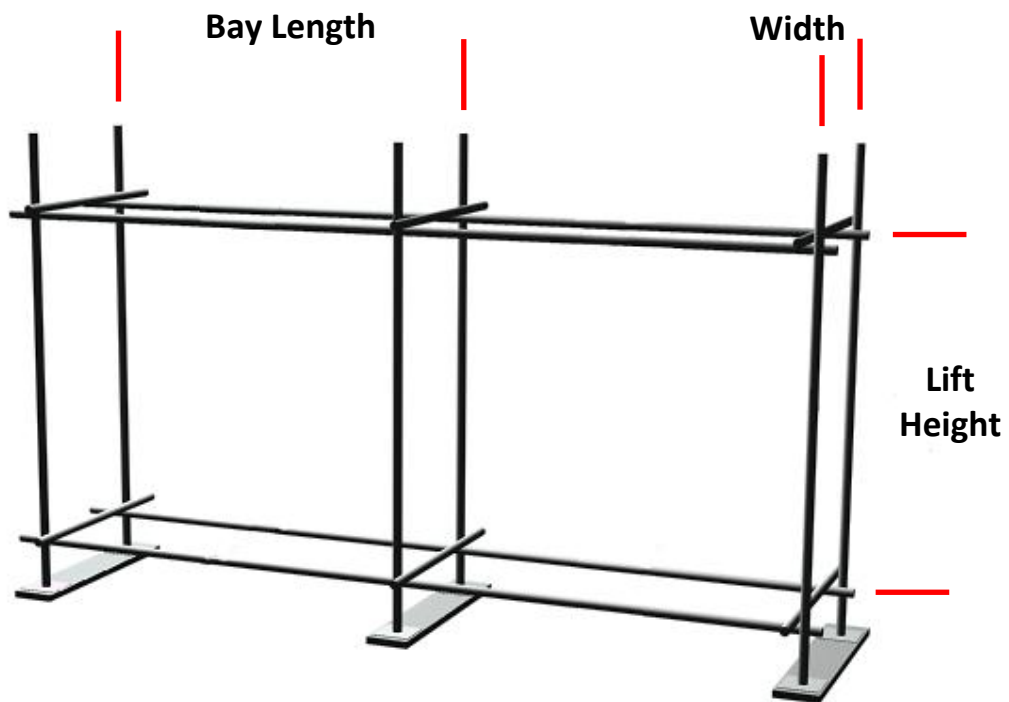

Figure 7 Scaffolding dimensioning terms

Figure 8 shows the protection of a working platform.

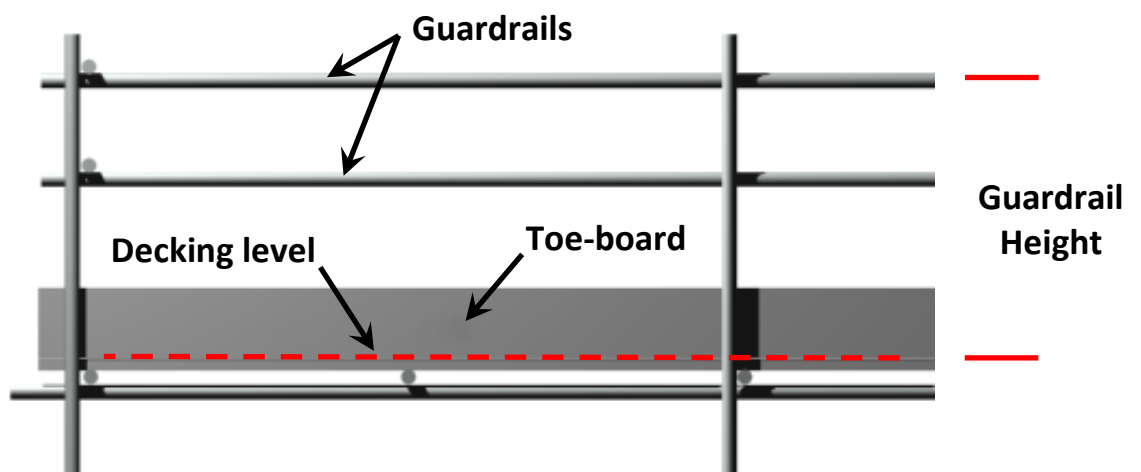

Figure 8 Guardrails and toe-boards

Toe-boards are needed to prevent tools or other things from falling over the side and striking someone beneath the scaffolds.

4 MAIN TYPES OF SCAFFOLDING SYSTEMS

4.1 Modular scaffolding

4.1.1 Introduction to modular scaffolding

Ideally, a scaffolding system has to be very flexible and fast to assemble. It must be erected quickly and efficiently.

Modular scaffolding is the most advanced type of scaffolding system. Being the common choice in Europe for complicated industrial structures and intricate facades it was chosen as the main subject of study in the present Thesis work.

Modular scaffolding provides enough versatility and reduces the time of assembly, compared to non-modular systems. High rigidity of joints gives more load-bearing capacity and height. Modular systems consist of standards with fixed connection points that accept ledgers, transoms, and diagonals that can be interconnected at predetermined (modular) levels.

All the main components of modular scaffolding, such as standards, ledgers, transoms, decks and diagonals, have uniform lengths and widths. The variety of choices is quite wide and that allows lots of adjustments to be made to suit any particular project. The versatility is very close to «Tube-and-Clamp» system.

At the same time utilizing standard hand-tools, modular system is fast-up and fast-down, minimizing labour costs and delays. This can be considered as the main advantage.

With its high versatility and fast assembly the modular scaffolding is especially suited for applications in industry, power stations, shipyards and special structures. But of course, it is also possible to provide façade scaffolding as well if the fast assembly and good versatility is needed.

4.1.2 Cup-Lock modular scaffolding system

The Cup-Lock modular system is a multi-purpose system which features the connection which allows up to 4 horizontal members to be connected to vertical member in one single clamping action without using of nuts, bolts or wedges. The locking device, formed by two cups, makes the Cup-Lock very fast, easy and versatile scaffolding system.

The typical Cup-Lock modular scaffolding joint principle is shown on Figure 9.

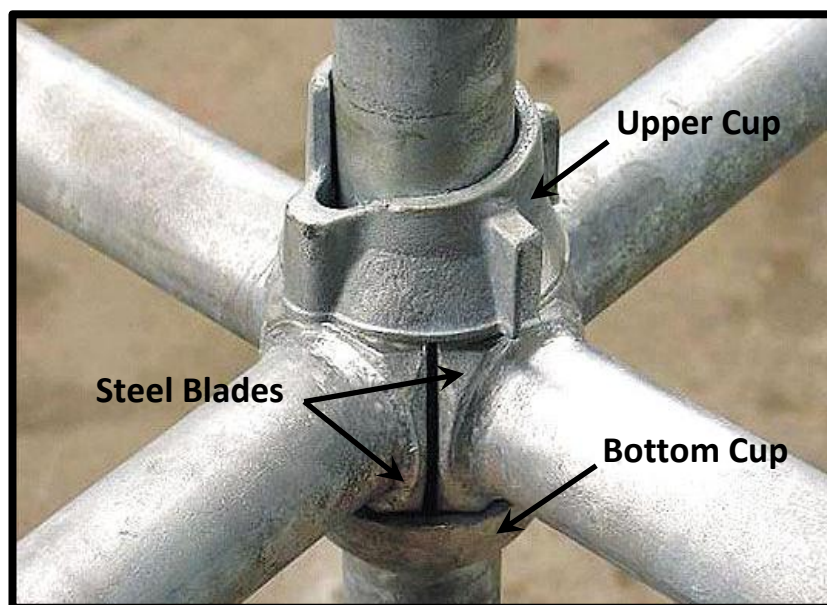

Figure 9 Cup-Lock joint principle

The **Bottom Cup** is welded to vertical tube and a movable **Upper Cup** is free to move up and down. Cups are made of different materials. Welded Bottom Cups are usually pressed from high quality steel, while the Upper Cups are made out of softer, forgeable casting. Horizontals or diagonals are usually made of 48,3mm steel tubes with special forged **Steel Blades** at the ends. The blades are placed into the Bottom Cup and locked in place with the Upper Cup, which is tightened by a hammer blow. This provides the firm grip, making the connection rigid and ready to endure rough building site handling.

4.1.3 Ring-Lock modular scaffolding system

The Ring-Lock Modular System is the most advanced scaffolding system on the market. It assembles quickly and easily, at the same time providing enough versatility to any building configuration. The centrepiece of the Ring-Lock System is the **Ring-Lock** itself, which is also called **Rosette Connector**. The horizontals and diagonals have special **Wedge Heads** with captive wedges. The stages of wedge driving are shown on Figure 10.

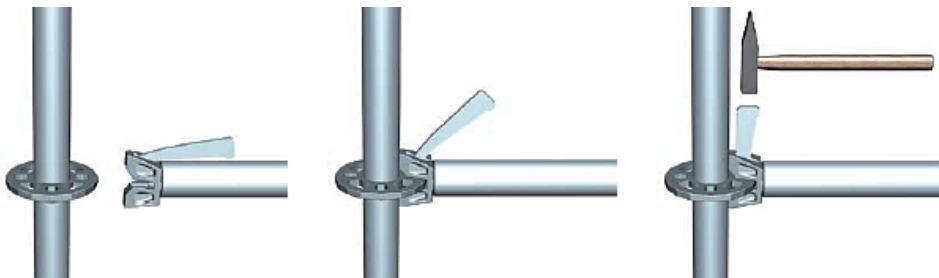

Figure 10 Wedge driving stages of Ring-Lock modular scaffolding system

Sliding the wedge head over the Ring-Lock and inserting the wedge into the opening immediately secures the component. There is still sufficient movements available needed to secure the other end of the ledger. Hammer is the only tool required for complete assembly. A hammer blow to the wedge transforms the loose connection into a strong structurally rigid one. As the wedge is driven, it is locked securely from any movement. Figure 11 shows the assembled joint.

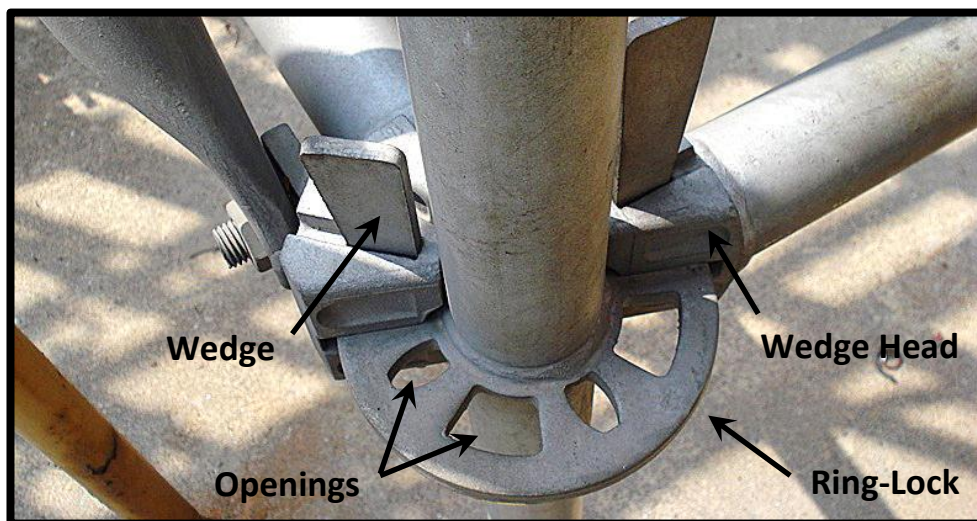

Figure 11 Ring-Lock joint principle

The working principle of Ring-Lock System is similar to the Cup-Lock System, but the difference is the **increased rigidity of the connections**. The flat design of the Ring-Lock is also helps to prevent from clogging the joint with dirt of whatever type.

There are 8 punched-out openings in the Ring-Lock. It is usually so, that 4 of them are the small ones, which automatically centre the ledgers at right angles. The other four openings are wider, which permit the alignment of ledgers and diagonal braces at the required angles. The design of the openings varies between the Ring-Locks from different manufacturers. It may be so that all the openings are of the same size. Figure 12 shows possible angle adjustments.

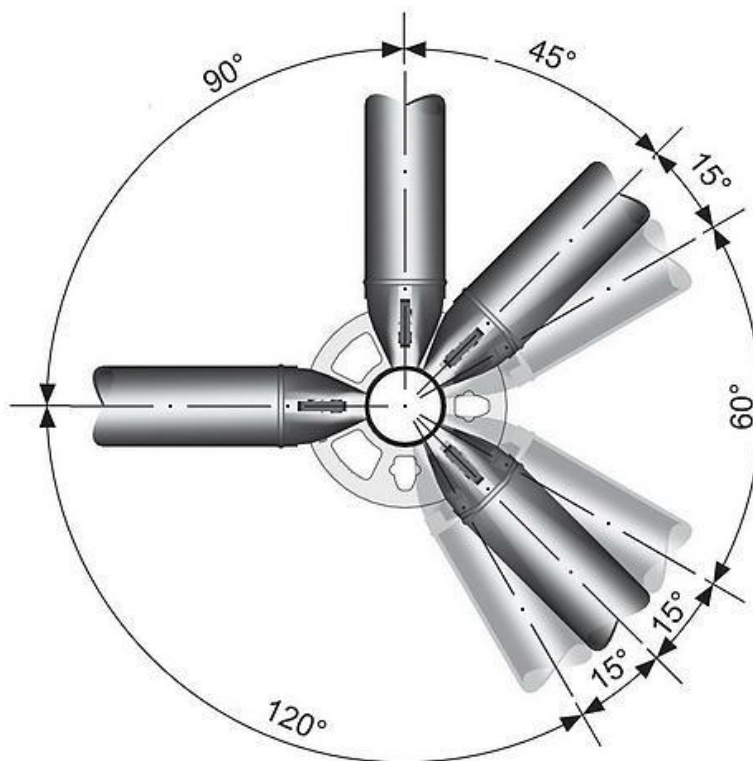

Figure 12 Angle adjustment scheme

It is obvious that the angle can be changed from 45° only if there is no adjacent element installed. And if the angle is changed than the adjacent narrow opening is blocked.

The Ring-Locks are commonly provided at the vertical members at a distance of 0,5 m. The ledgers and transoms have modular dimensions and the lengths of

diagonals are designed according to bay length and installation height. Exemplary element variety of the Ring-Lock modular system is shown on Figure 13. The principle is the same for any modular system.

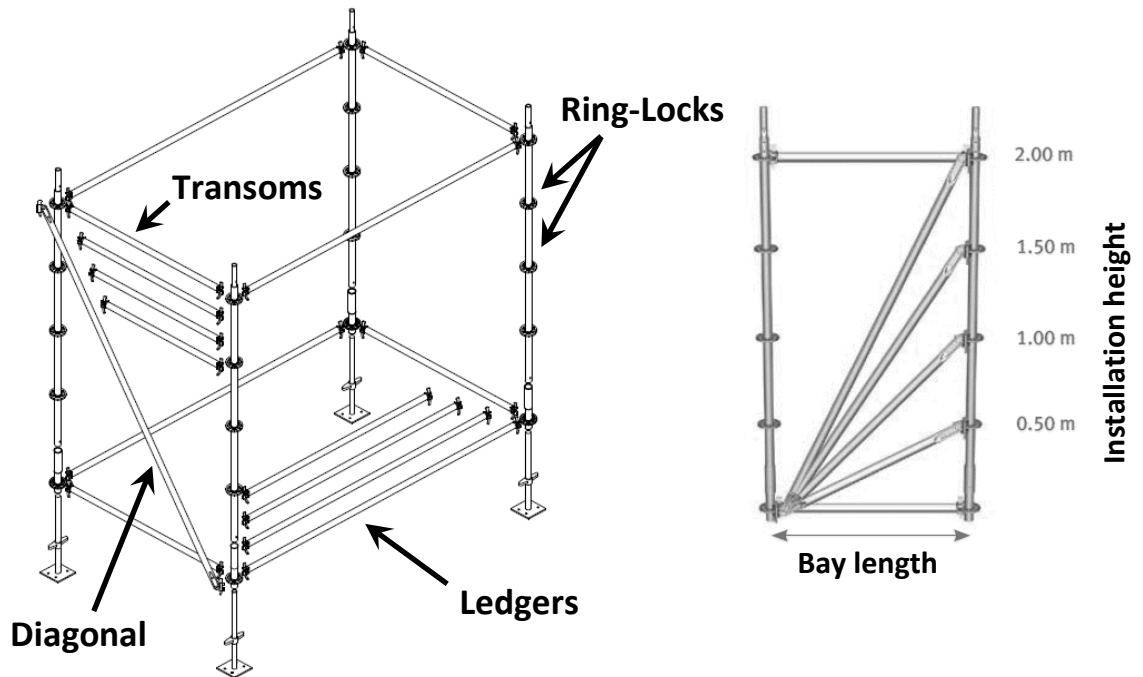

Figure 13 Ledgers, transoms and diagonals in different lengths

Thus, the modular systems can be easily adjusted to the most complex layouts.

Also it is necessary to mention the important element called «starter». It is shown on Figure 14.



Figure 14 Starter element

Starter is fixed on an adjustable base jack. It facilitates the horizontal alignment and gives the possibility of racking of standards by the only one person.

4.2 Tube-and-Coupler scaffolding

«**Tube-and-Coupler**» (also called «**Tube-and-Clamp**») is a type of scaffolding consisted of tubes and couplers.

The main advantage of the tube-and-coupler scaffold is that horizontal tubes with walking decks can be placed at any height of vertical tubes. At the same time vertical tubes can be spaced at any distance apart. Maximum distances are restricted only by engineering constraints.

«Tube-and-Coupler» scaffolding requires a lot of labour input for assembly, because it is not a modular system. Generally it is used for work on non-rectangular, curved and irregular shaped structures, where unlimited versatility is needed.

This type of scaffold is very popular in North American nuclear power plants.

Vertical tubes are connected to horizontal with **Right Angle Rigid Couplers**. These couplers are shown on Figure 15.



Figure 15 Tubes connected with Right Angle Rigid Couplers

It is obvious that rigid couplers do not allow rotation of elements. They can be connected only with right angles.

Diagonal tubes which are used to stabilize scaffold are connected with **Swivel Couplers**. These couplers are shown on Figure 16.

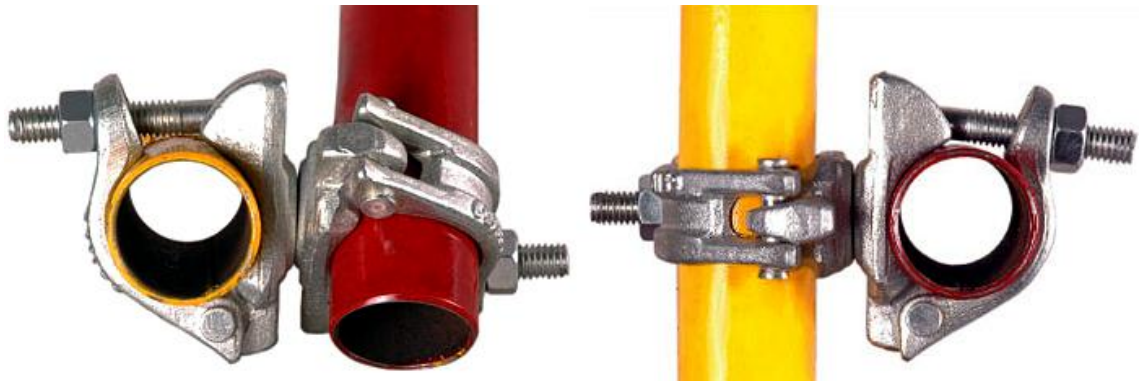

Figure 16 Tubes connected with Swivel Couplers

On the images above the tubes are painted, while the couplers are hot-dip galvanized. Figure 17 shows common «Tube-and-Coupler» scaffolding. It is noticeable that transoms, which bear decks, are connected to standards on higher than longitudinal ledgers. It is done so to ensure that if the coupler that holds bearing transom fails or slips down it will find a support on the ledger.

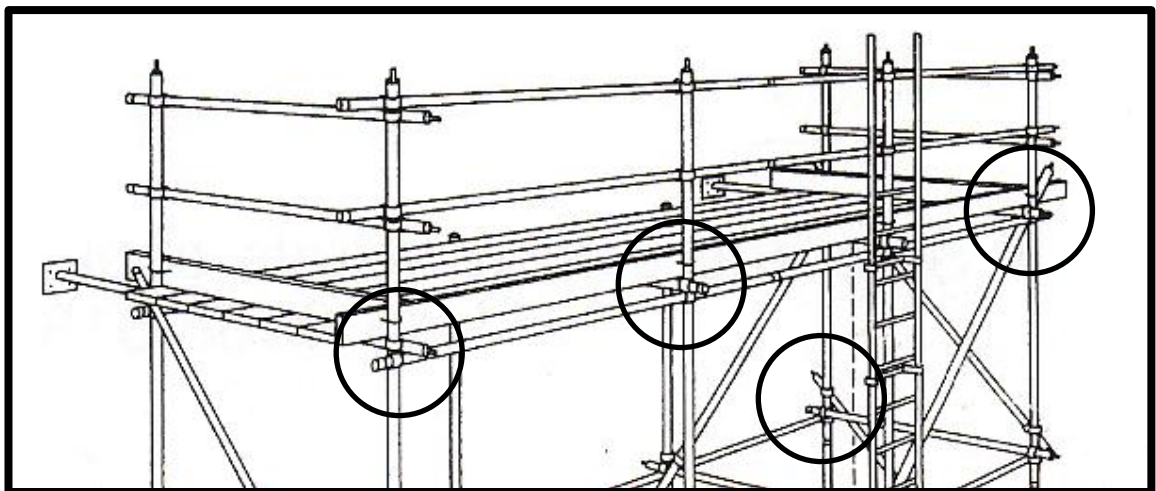

Figure 17 «Tube-and-Coupler» scaffolding

«Tube-and-Coupler» is for sure the most versatile scaffolding system on the market. With movable couplers it is possible to adjust the system to any conditions, creating different distances between the elements. The problem is that the rigidity of coupler joints might be insufficient and also the labour input which is needed for assembly is too high.

4.3 Fabricated frame scaffolding

Fabricated frame scaffolding (also called **Tubular welded frame scaffolding**) features manufactured welded frames made in various heights and widths. The principal scheme is shown on Figure 18.

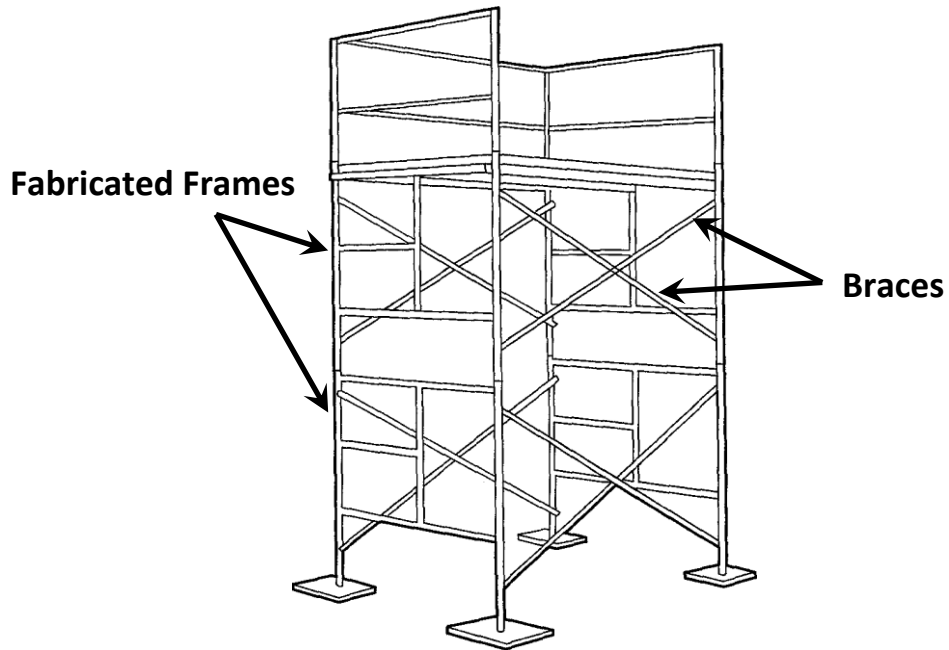

Figure 18 Principal scheme of tubular welded frame scaffolding

Frames are supported by cross, horizontal or diagonal braces, or a mixture of braces, to stabilize vertical members and to insure the rigidity of the whole scaffolding system. Brace connections must be securely fastened.

Figure 19 below shows the most advanced and quick brace-fastening system, which is now used by many scaffolding manufacturers.

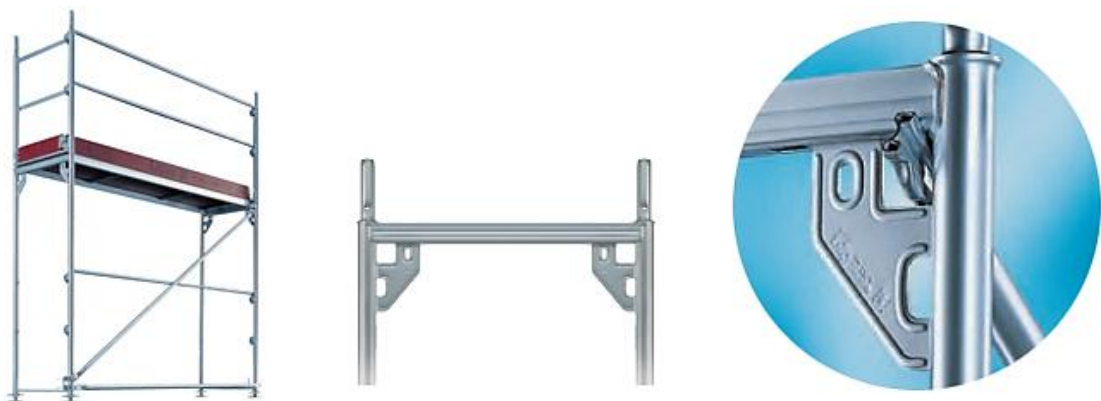

Figure 19 Modern way of fastening the braces

Older frame scaffolding systems featured locking pins, welded to the frames. Such pins also allow to connect braces and to secure them without using any special tools. The main principle is shown on Figure 20.

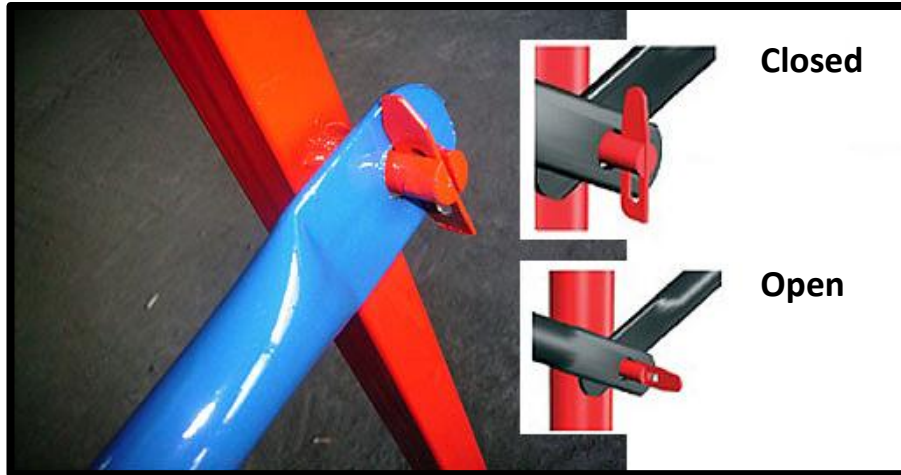

Figure 20 Locking pin work principle

In any system the braces have a fixed length that automatically squares and vertically aligns vertical members so that the erected scaffold is always square and rigid. The scaffold is extended by adding braces and frames until the desired length is reached. Scaffold height is increased by stacking end frames on top of each other. The bottoms of the legs of the upper end frames slide into the tops of the legs of the lower end frames and are joined together with coupling pins.

Compared with «Tube-and-Clamp» system the fabricated frame scaffolding is much easier and faster to assemble, but its versatility is many times lower. It is not easy to repeat a complicated shape with this system.

4.4 Mobile scaffolding

Mobile scaffolding is a powered or non-powered portable caster or wheel-mounted scaffolding. It can be constructed of any components: tube and coupler, fabricated frames or modular elements and must conform to design, construction and loading requirements for those scaffolding systems. The scaffolds must be braced by cross, horizontal or diagonal braces, or combination thereof, to prevent buckling or collapse. (N.C. Department of Labor. Occupational Safety and Health Division 2008, p. 23)

On Figure 21 below it is shown the mobile scaffold, assembled from fabricated frames and braced by cross braces.

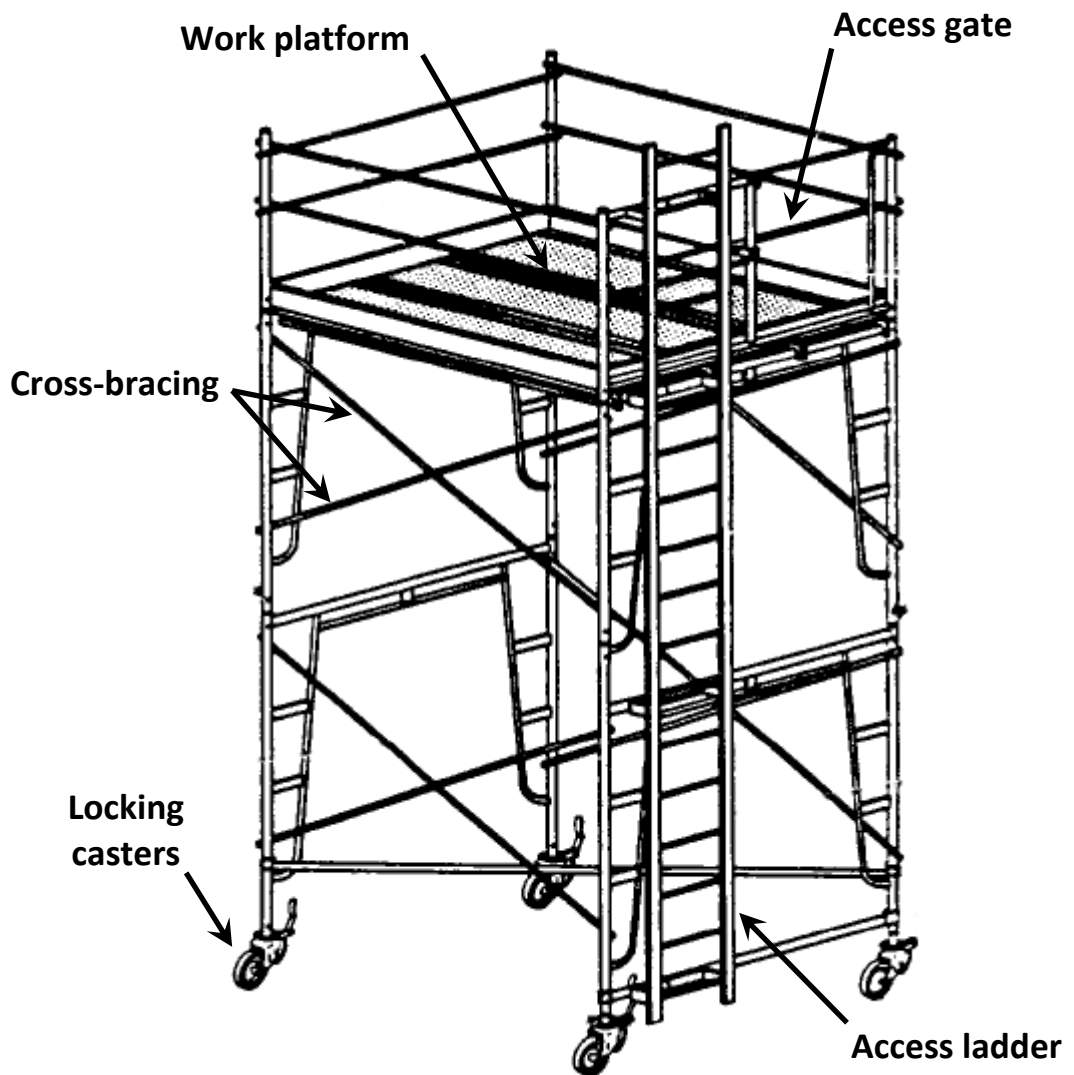

Figure 21 Fabricated frame mobile scaffolding

Caster and wheel stems are pinned or otherwise secured in scaffold legs. While in a stationary position, casters and wheels must be locked with a positive wheel and/or wheel and swivel locks, or equivalent means, to prevent movement.

When manual force is used to move the mobile scaffold, the force should be applied as close to the base as practicable.

Figure 22 shows the mobile scaffold gantry for the installation of tunnel sheet membrane and concrete lining steel reinforcement at the Brisbane Airport Link, Australia's largest road infrastructure project.



Figure 22 Modular mobile scaffold gantry in the tunnel, Australia

Two access gantries were assembled on electric driven steel frame wheel bogies travelling on rails. Scaffold gantries were decided to be most desirable as they provide the greatest flexibility for modification with expected tunnel profile changes. (Layher GmbH & Co. KG. Australian website).

5 MAIN RUSSIAN MANUFACTURERS OF MODULAR SCAFFOLDING SYSTEMS

5.1 RINSTROY Ltd.

RINSTROY Ltd. is a huge manufacturer of building equipment. It produces scaffolding systems up to 100 metres in height, formwork, ladders, protection nets, cover materials, concrete mixers and other different equipment.

Scaffolding systems made by RINSTROY are fixed-frame, tube and clamp, and the most advanced Modular Ring-Lock system.

Modular Ring-Lock system allows usage of scaffolding in the projects of any complexity level.

Innovative detail, which distinguishes modular scaffolding made by RINSTROY from the other manufacturers, is that they use plastic deformation in production of vertical standards (Figure 23).

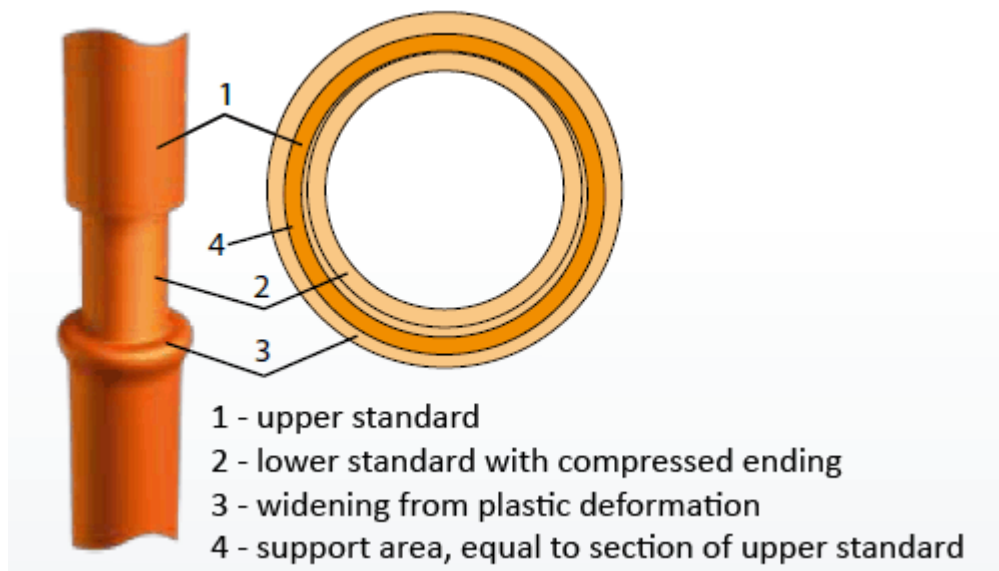

Figure 23 Plastic deformation of the ending of vertical standard by RINSTROY

No welding is used to attach the Ring-Lock/Rosette to the tube. It is shown on Figure 24 below.



Figure 24 Ring-Lock by RINSTROY, secured on tube by plastic deformation

Such connection provides increased stiffness and stability compared to spigot fitting assembled by putting the tube of less diameter into the vertical standard, like described on Figure 25 and 26 below.

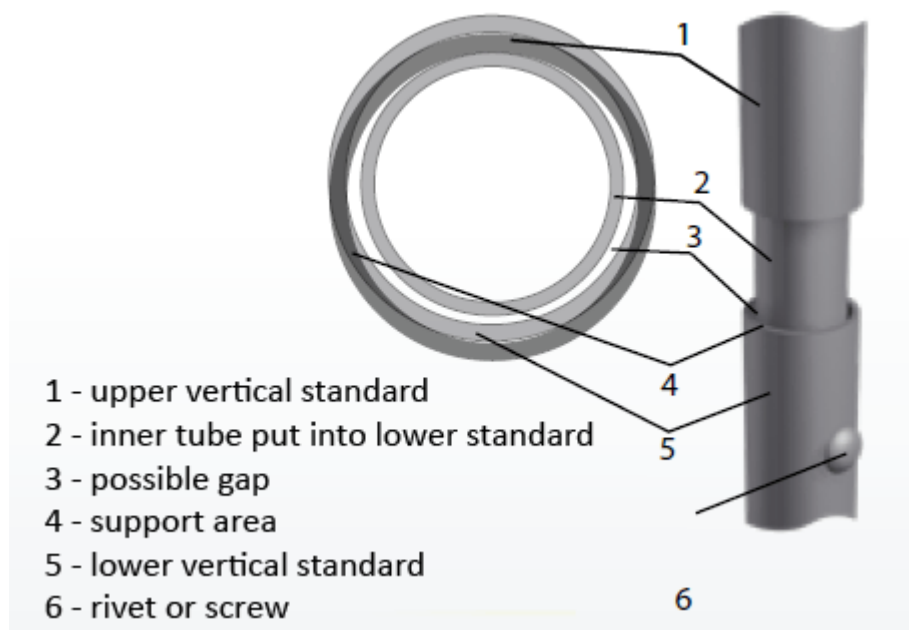

Figure 25 Common spigot fitting with an additional inner tube

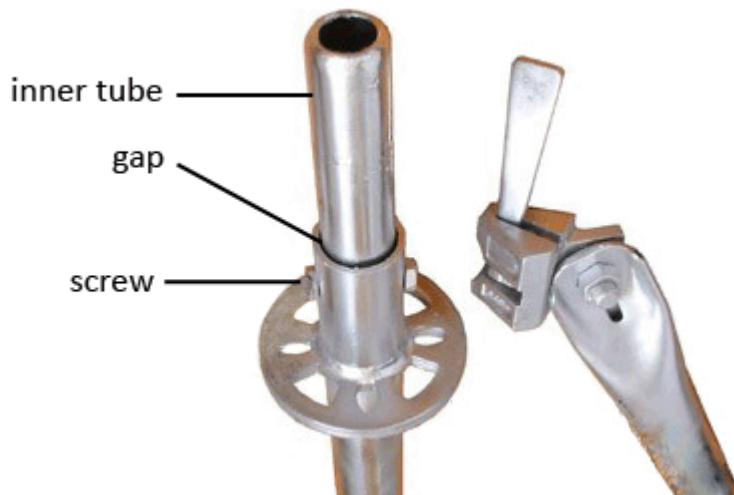

Figure 26 Common spigot fitting with additional screwed inner tube and welded Ring-Lock

Below is the table of main characteristics of Ring-Lock scaffolding system by RINSTROY (Table 1).

Table 1 Main characteristics of the scaffolding system by RINSTROY

Tube diameter	48 mm			
Maximum height	up to 100 m			
Lift height	2,0 m			
Scaffolding width	1,0 m			
Bay length	1,0 m	2,0 m	2,5 m	3,0 m
Max load applied to the deck, kg/m ²	350	300	250	200

There is the only choice of scaffolding width mentioned because of the wooden decks which are 1,17x0,95m and lay upon the longitudinal ledgers. No other types of decks available from RINSTROY. Load-bearing capacity is taken from the manufacturers manuals and like it is told there it depends on the bay length (distance between the standards along the facade).

Vertical distance between the Ring-Locks is normally 1m, but 0,5m can be made by special order. All the elements are painted in company's black and orange colours.

5.2 MDN-Prom Ltd.

MDN-Prom Ltd. produces all types of scaffolding systems, which are in common use on Russian construction sites: fixed frame, tube and clamp and ring-lock scaffolds. Production factories are located in two cities – Serpuhov and Unecha. The most advanced systems are Modular Ring-Lock Scaffolding **LSK-60** and **LSK-100**, suitable for all the works up to 60m and 100m in height. Difference between these two types is in the **wall thickness** of tubular vertical standards, which is **2mm** for **LSK-60** and **3mm** for **LSK-100**.

Vertical standards are done in a common way – Ring-Lock is secured by welding (Figure 27). No plastic deformation is used here, like they do it in RINSTROY. Spigot fitting provides connection of vertical standards (Figure 28).

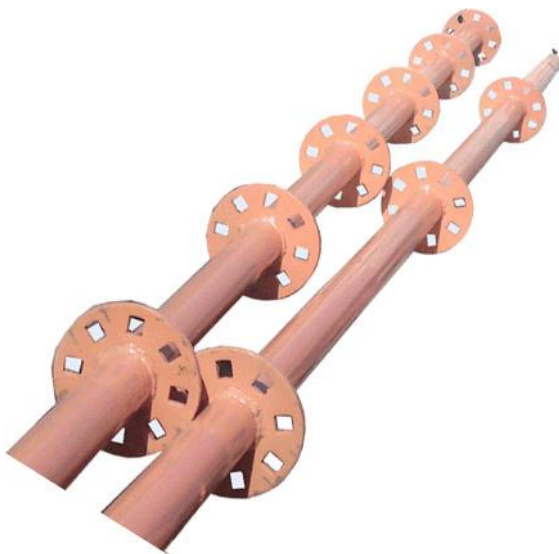

Figure 27 Vertical standards with welded Ring-Locks by MDN-Prom



Figure 28 Spigot connection of standard

Previously, MDN-Prom was manufacturing the joint that allowed attaching only four elements simultaneously. The sizes of wedge heads were way too big to put diagonals next to ledgers. Left image on Figure 29 clearly shows this.

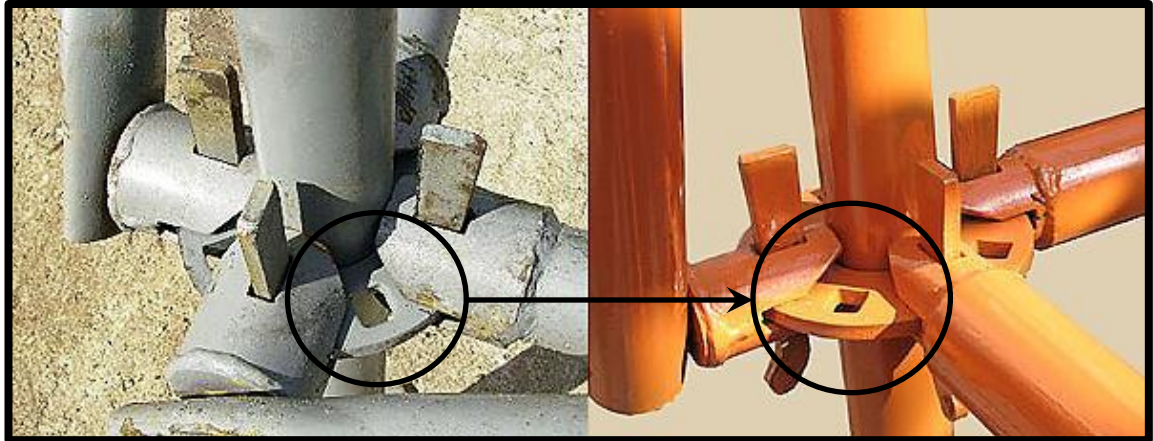

Figure 29 Development of Ring-Lock joint by MDN-Prom

Last year the company redesigned the wedge heads making them smaller (right image on Figure 29), so that now all the 8 elements can be connected to the Ring-Lock at the same time. This small improvement considerably increases the versatility of the whole system. Below is the table of characteristics of Ring-Lock Scaffolding by MDN-Prom 9 (Table 2).

Table 2 Main characteristics of the scaffolding system by MDN-Prom

	LSK-60			LSK-100	
Tube diameter, mm	48 mm				
Tube wall thickness, mm	2 mm			3 mm	
Maximum height, m	60 m			100 m	
Lift height, m	2,0 m ; 3,0 m				
Bay length, m	1,0 m ; 1,2 m ; 1,5 m ; 2,0 m ; 3,0 m				
Scaffolding width, m	1,0 m	1,2 m	1,5 m	2,0 m	3,0 m
Max load applied to the wooden decks, kg/m ²	270	225	180	135	90
Max load applied to the metal decks with strengthened ledgers, kg/m ²				500	

Like RINSTROY, MDN-Prom normally equips its scaffolding with wooden decks. However, they can offer longer, than common square 1x1m decks. The load-bearing capacity in this case decreases while increasing the width, because the wooden decks are meant for resting upon the longitudinal ledgers. It is shown on Figure 30 below.

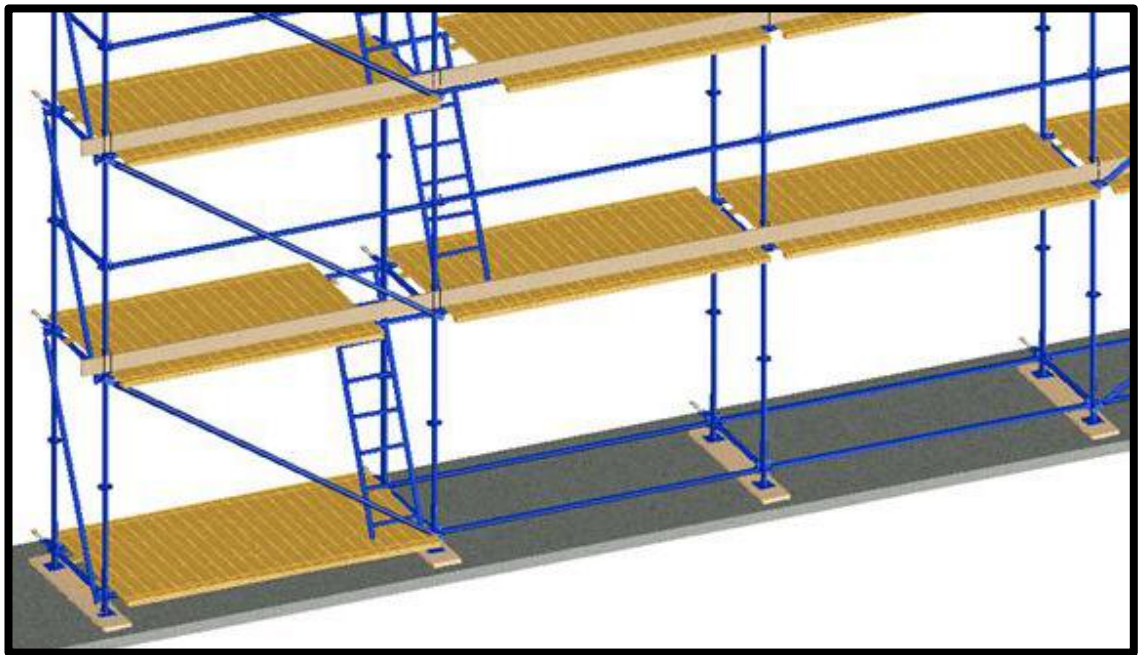

Figure 30 Wooden decks laying upon the longitudinal ledgers

To increase the maximum load supported it is possible to use special horizontal elements, trusses-like, with long metal decks. They are shown on Figure 31.



Figure 31 Strengthened horizontal element and long metal deck

By doing so the load-bearing capacity of LSK scaffolding reaches its maximum of 500 kg/m². Thus the scaffolding system becomes suitable for doing brickwork.

All the scaffolding elements by MDN-Prom are painted.

5.3 Monolit Stroy Komplekt Ltd. (MSK)

Monolit Stroy Komplekt Ltd. (MSK) specializes in manufacturing steel constructions. Huge part of their produce belongs to scaffolding. Systems they offer are «tube and clamp» and modular Ring-Lock system.

MSK divides their Ring-Lock system into two types – professional and light weighted. Professional consists of the tubes 60 mm in diameter and can reach up to 100 m in height, while light weighted features common 48 mm thick tubes.

Ring-Lock is secured on the standard by welding. The Ring-Lock itself provides the possibility of immediate connection of 8 horizontal elements: ledgers, transoms and cross bracers. The joint is shown on Figure 32 below.



Figure 32 Ring-Lock joint by MSK

Table 3 Main characteristics of the scaffolding system by MSK

Tube diameter	60 mm	48 mm
Maximum height	up to 100 m	up to 80 m
Lift height	2,0 m	2,0 m
Scaffolding width	1,0 m	1,0 m
Bay length	3,0	3,0
Max load applied to the deck, kg/m ²	200	200

All the tubes are painted red using powder method.

5.4 SIMAN+ Ltd.

SIMAN+ Ltd. was established in 2003. The main specialization of the company is production of different scaffolding types.

Systems, which are being produced by SIMAN+, are common Fabricated Frame Scaffolding and Modular Ring-Lock System. The Ring-Lock in the modular system was quite similar to other companies, featuring the same kinds of openings in rosette, allowing to attach up to 8 elements simultaneously.

Normally their scaffolding is equipped with simple squared wooden decking (which restricts the width to be no more than 1m) like previously mentioned manufacturers. But as well as with MDN-Prom it is possible to order from SIMAN+ the metal decks along with strengthened horizontal elements to reach the maximum load bearing capacity of 600 kg/m². It is the highest among all the manufacturers described.

Table 4 Main characteristics of the scaffolding system by SIMAN+

Tube diameter, mm	48		
Maximum height, m	80		
Lift height, m	2,0		
Bay length, m	1,0	2,0	3,0
Max load applied to the deck, kg/m ²	200		
Max load applied to the metal decks when using strengthened ledgers, kg/m ²	600		

In the year of 2005 SIMAN+ invented its own type of joint that allows connection of elements to vertical standard at any angle. This joint was designed to be used when making scaffolding for buildings and structures of complicated or spherical shapes. The main principle of this joint is explained on Figure 33 below.

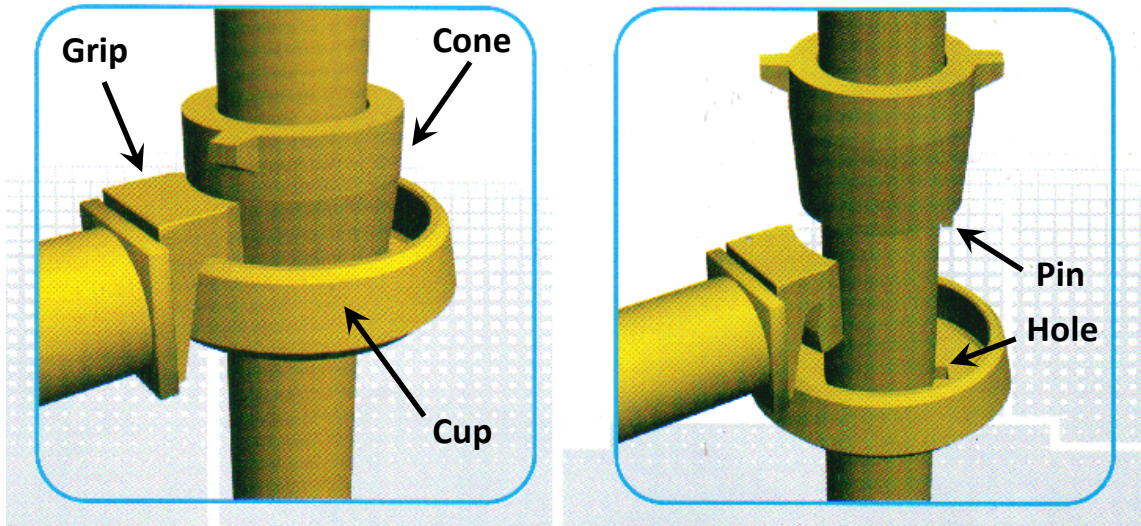

Figure 33 Patented joint by SIMAN+

The joint consists of **Bearing ring** or **Cup**, **Grip** and the **Cone**. Bearing Ring looks like a cup with thickened walls and plate-like bottom that is secured on the vertical standard. Bearing ring is shown on Figure 34.



Figure 34 Bearing ring / Cup

It is noticeable that the bearing ring has a small cutting out in its inner circle. A pin on the cone is being inserted into it, which prevents rotation.

Special grips are the necessary parts of each horizontal or diagonal. Inner surface of the grip retraces the surface of the cup wall while the outer surface retraces the cone. The grips are fully casted. One is shown on Figure 35.



Figure 35 Grip

During the assembly process the grips are put onto the bearing ring and then jammed by the cone with hammer blows applied. Cone itself is located on the vertical and freely moves up and down. In its bottom part it has a locking pin, which goes into the hole in the cup (Figure 36) and, like it was told above, secures the cone from rotation. The pin is 2 centimetres long. It is enough to ensure that the cone is not moving.

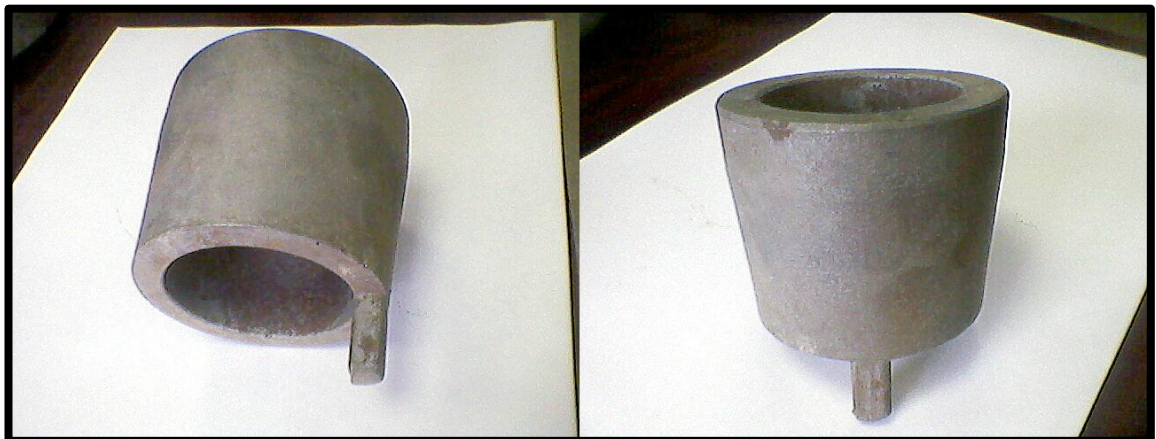

Figure 36 Cone with a locking pin

Hammer blowing begins after inserting the locking pin into the hole in the cup. The cone then goes deeper and jams the grips. The joint becomes rigid.

This joint has no analogues in Russia. It is the patented system, which belongs to SIMAN+. It can bear more load than the common Ring-Lock and is very flexible, but it is not much used and being produced only by special orders. The

reason for this is that in most cases the versatility of the Ring-Lock joint is enough. And with the cup and the cone instead of rosette the joint becomes heavier than the simple Ring-Lock. It is its main weak point

SIMAN+ produces one more joint, which is called the «Star» (Figure 37). New connection features 8 narrow openings to attach the elements. It replaced the disc-like rosette that had been manufactured earlier.

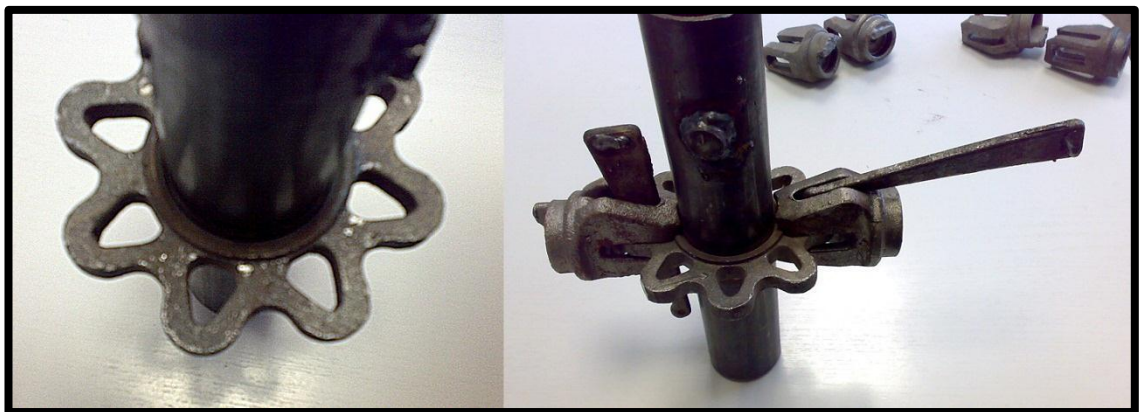

Figure 37 «Star» joint by SIMAN+

Manufacturer states that the main reason for replacing 4 narrow and 4 wide openings with 8 narrow ones is the increased precision of assembly. They think that the scaffolding becomes more safe if all the elements are attached to the narrow openings, especially shaped for rigid connection. On Figure 38 below there are eight grips shown, connected simultaneously to the same star.



Figure 38 Connection of elements to the «Star» joint

So in SIMAN+ they decided to sacrifice the possibility of adjusting the angle, gaining more secure connection of elements. One more advantage of the «star» is the weight reduction, compared to disc-like Ring-Lock.

Like the other Russian manufacturers in SIMAN+ they apply paint coating to their elements using the powder method.

6 COMPARATIVE ANALYSIS OF RUSSIAN RING-LOCK SCAFFOLDING SYSTEMS

Systems described above are the most widely used ones produced in Russia. The Ring-Lock type scaffolding itself is not so widely used as simpler «Tube-and-Clamp» system or the scaffolding made of fabricated ready-made frames.

The reasons for that are the following. The Ring-Lock type scaffolding gives sufficient versatility together with high load bearing capacity. But often happens so that there is no need to bear heavy loads or to provide big heights. In addition to it, if the shape of facade is very complicated then «Tube-and-Clamp» system wins, providing the highest versatility available for scaffolding. Also it is quite usual situation that the shape of façade is so plain and simple that it is much easier to construct the scaffolding from ready-made frames.

Russian scaffolding comes with paint finish only. There are no manufacturers who offer hot-dip galvanized elements. Painted scaffolding is cheaper, but less durable.

All Ring-Lock systems described above possess their own load-bearing capacities. According to manufacturer's manuals it varies dependable on bay length or width. The main figures are listed in the table 5.

Table 5 Load-bearing capacities of Russian scaffolding systems

System by Bay length	1,0m	1,2m	1,5m	2,0m	2,5m	3,0m
RINSTROY	350	-	-	300	250	200
MSK	-	-	-	-	-	200
SIMAN+	200	-	-	200	-	200
+ strengthened elements	600			600		600
System by Width	1,0m	1,2m	1,5m	2,0m	2,5m	3,0m
MDN-Prom	270	225	180	135	-	90
+ strengthened elements	-	-	-	500	-	500

Width of the scaffolding is very important parameter. Bigger variety of widths available – more versatile is the scaffolding. It is so, because different kinds of works require different amount of space.

Table 6 Widths of scaffolding available from Russian manufacturers

System by Width	1,0m	1,2m	1,5m	2,0m	3,0m
RINSTROY	✓				
MDN-Prom	✓	✓	✓	✓	✓
+ truss-like transoms				✓	✓
MSK	✓				
SIMAN+	✓			✓	✓

It is obvious from the table that the only two manufacturers, MDN-Prom and SIMAN+, offer quite good variety of widths for its scaffolding.

Like it was mentioned previously RINSTROY Ltd. manufacturers very modern Ring-Lock joint and uses plastic deformation to make the spigot fitting needed for connection of the vertical standards. Also the Ring-Lock itself is not welded to the tube, but firmly secured using the same method. The company claims that when using the welding it might happen so that it is done not very precise and the durability of the joint is decreased.

Featuring such an up-to-date system, the RINSTROY scaffolding possesses very low versatility regarding to the only one choice of width – one metre. The company manager answers that it is so, because they are using the standard wooden decks, which are squared and can be only 1m in width. They lay upon the longitudinal ledgers. That is why the width can be only 1 metre. It is shown on Figure 39 below. And there is no possibility to make a special order for another kind of decks.

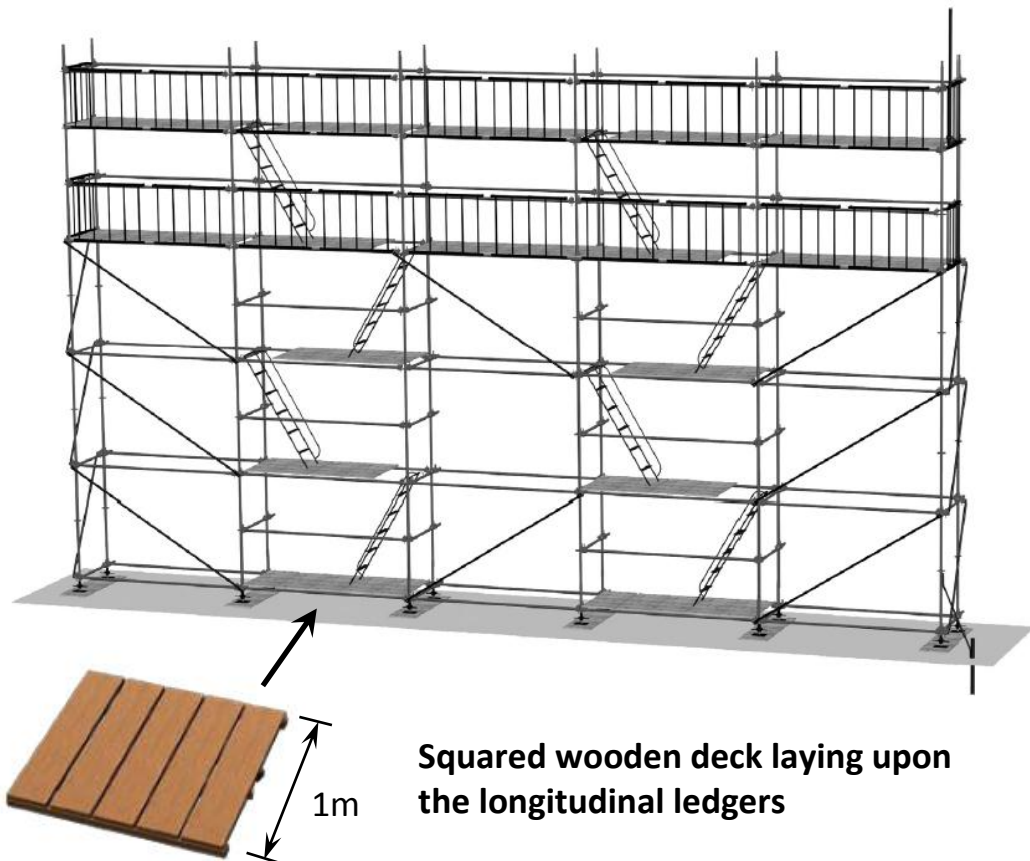

Figure 39 Scaffolding by Rinstroy. Wooden decking.

The same situation is with the scaffolding systems by MSK. The width can be only 1 metre like from RINSTROY. MSK, however, is the least versatile system between all of them, offering the only one choice of bay length – 3 metres.

It is a very common problem with Russian scaffolding systems that they are so narrow. While possessing the advantage of modular systems to be of any width, it is not used completely, because of the narrow decking.

SIMAN+ featuring innovative patented joints offers the choice of three bay lengths, and three widths. The width is not limited to one metre, because they offer not only squared wooden decks, but long metal ones also (Figure 40).

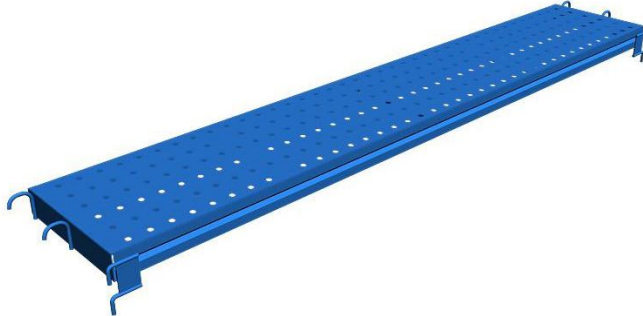

Figure 40 Metal scaffolding deck

Long metal decks lay upon the transversal transoms. In this case the width is limited only with the length of the transom available.

Biggest variety of elements is available in the scaffolding system LSK by MDN-Prom. Scaffolding width as well as the bay length can be 1,0 ; 1,2 ; 1,5 ; 2,0 ; 3,0 metres. The decks are squared wooden ones or metal modular decks 2,0 and 3,0 metres in length. Not a long time ago they also updated their Ring-Lock disc, making it so that all the eight elements are ready to be connected at once.

LSK system by MDN-Prom and system by SIMAN+ can bear the heaviest loads among the other competitors. The maximum distributed load can be up to 500 kg/m² with LSK and 600 kg/m² with the system by SIMAN+. Manufacturers state that this load-bearing capacity can be achieved by using the strengthened horizontal elements along with metal decking.

But LSK scaffolding by MDN-Prom has a weak point in the wedge heads, compared to ones, produced by other Russian manufacturers. The wedge head is not made of fully casted steel, but welded from two parts. That makes it possible for some defects to appear in the welding seam and reduce its strength. The wedge heads by RINSTROY, SIMAN+ and MSK are fully casted. The difference is visible on Figure 41.



Figure 41 Wedge head by MDN-Prom (left) and fully casted wedge heads by RINSTROY, SIMAN+ and MSK (right)

Summarizing the advantages and disadvantages of each scaffolding system I think that the SIMAN+ is the best manufacturer among the others. The company pays great attention to development of their scaffolding, introducing new ideas and having their own view of the ideal joint. Offering the choice between three bay lengths and three widths makes their system quite flexible and ready to be used not only for facade works but for more complicated tasks as well. Moreover, with strengthened horizontal elements and metal decking it is possible to achieve the maximum load-bearing capacity up to 500 kg/m². The company is ready to consider any wish of the customer and respond according to the goals defined.

7 COMPARISON OF RUSSIAN SCAFFOLDING SYSTEMS WITH THE ONES COMMONLY USED IN FINLAND

There are no Finnish scaffolding manufacturers and the systems used on the construction sites and industrial objects in Finland are in most cases German-made. The most popular are Ring-Lock systems by Alfix, Layher, Peri and Plettac. All these systems are quite similar by principle of work and materials used. For the comparison Alfix Module II Plus scaffolding system was chosen.

The main disadvantage of the Russian Ring-Lock scaffolding systems is a poor variety of elements available. Being modular, there is a need for good catalogue

of elements to choose from. This fact leads to very low versatility, compared to German scaffolds.

For example, the bay lengths available from the MDN-Prom are 1,0 m ; 1,2 m ; 1,5 m ; 2,0 m ; 3,0 m. Five different lengths of tubes. And two strengthened transoms 2,0 and 3,0 metres in length to carry the higher loads. And it is the richest choice between all the manufacturers. On the other hand, German Alfix offers 13 tube lengths from 0,36 to 4,14 metres. Moreover, there are also reinforced and double-tube ledgers and transoms available. Transoms can be U-shaped, which is needed to carry different kinds of decks (Alfix Scaffolding System Modul PLUS II Catalogue). The variety is shown on Figure 42. Figure 43 illustrates special U-shaped transom.

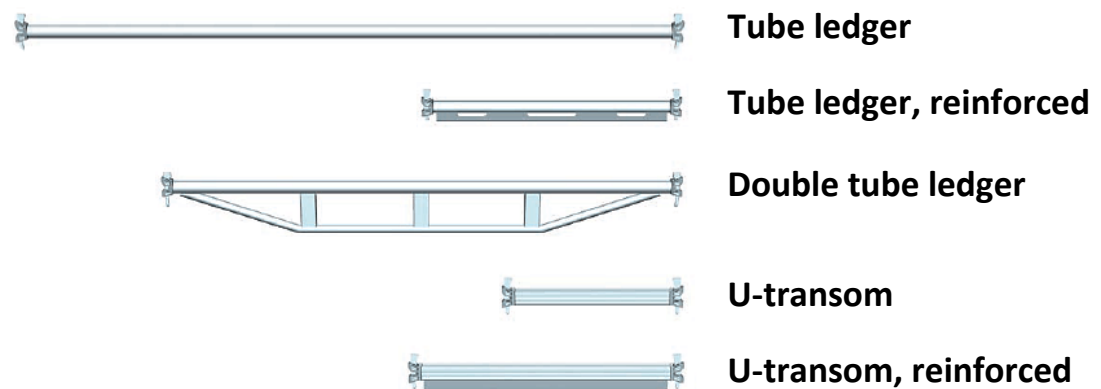

Figure 42 Different types of ledgers and transoms by Alfix



Figure 43 Deck carried by U-shaped transom

The Ring-Lock joints themselves are quite similar (Figure 44). European manufacturers, and Alfix among them, prefer to manufacture it as a disk with 8 openings – 4 of them are the small ones, which centre the ledgers at right angles. The other 4 openings are wider, which permit to vary the angle. Ring-Locks by RINSTROY and MSK are done the same. The Ring-Lock disk by MDN-Prom and the star by SIMAN+, however, feature 8 small openings, sacrificing the possibility to adjust the angle, but keeping the assembly process more precise.



Figure 44 Ring-Locks from left to right: Alfix, RINSTROY, MDN-Prom, SIMAN+

It is quite difficult to tell if it is better to keep all the opening small or not. SIMAN+ had been manufacturing the same Ring-Lock like Alfix or RINSTROY before they went to the star connection. When they were asked about the reason for that, it was told that the star is more reliable and at the same time more lightweight. There is no possibility for elements to get loose or to move inside the narrow slot. That is the reason they stated.

The diameter of tubes used for scaffolding is the same for Russian manufacturers and for Alfix, being 48 mm with wall thickness of 3 mm. But the finish is different. While all the Russian manufacturers paint their tubes, German-made scaffolding elements are always hot-dip galvanized. It makes them be more rust-resistant and long-lasting.

The wedge heads by Russian manufacturers and by Alfix are made similarly from fully casted steel. Only the wedge head by MDN-Prom is quite outdated, being welded from separate details, like it was told in the previous chapter. Figure 45 below shows the casted wedge heads by Alfix and SIMAN+.

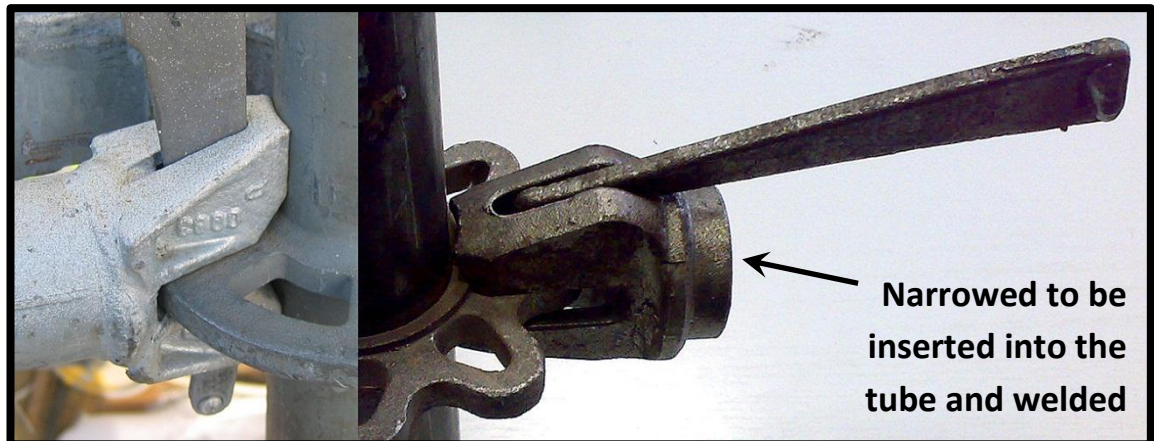

Figure 45 Wedge heads by Alfix (left) and SIMAN+ (right)

Another fact about Russian scaffolding is that while possessing good engineered joints their capacity cannot be used entirely, because of the wooden decks that are not able to carry loads higher than 200 kg/m^2 on average or the lack of strengthened elements. Only two of four manufacturers described earlier, which are MDN-Prom and SIMAN+, can provide the load bearing capacity up to 500 and 600 kg/m^2 , respectively, by using metal decking with strengthened ledgers. German Alfix offers the choice between different decks of various load bearing capacities with a maximum of 600 kg/m^2 . Reinforced and double-tube ledgers and U-transoms are ready to complete the high load bearing system. One more problem with wooden decks is that they are usually not compliant with fire-safety demands when the scaffolding is assembled at a hazardous industrial object such as an oil refinery.

It is obvious that German scaffolding is more advanced compared to Russian, providing wider variety of elements, better finish and more complete technical documentation. But manufacturers in Russia are constantly improving their products. Some companies, like RINSTROY or SIMAN+, develop their own types of joints. Scaffolds by MDN-Prom and SIMAN+ are quite versatile and can possess the load-bearing capacity comparable to German systems. And the price of Russian-made scaffolding is much lower – up to two or three times. That is the main reason why German systems are not so widely-spread on Russian construction sites.

8 RUSSIAN REGULATORY DEMANDS FOR SCAFFOLDING

8.1 Introduction to Russian standardization system

Russian standardization system underwent significant changes in the end of 2002 year. Federal Law №184 from 27th of December 2002 brought the idea of documents called literally «**Technical Regulations**». They were supposed to replace the existed standardization system that consisted of regulation documents, called **GOST** standards (an acronym for **GO**sudarstvennyy **ST**andard, which means «state standard») and **SNiP** (**Stroitelnye Normy i Pravila**, which means «construction norms and regulations»). The usage of the old norms became voluntary. «Technical Regulations» on the other hand are mandatory, but they set only minimal requirements concerning the safety. It was planned so that only the safety questions should be regulated.

For example, Technical Regulation «On safety of buildings and structures» states that the structure must be designed and built so that while human being stays inside no harmful effect to his health occurs. And it provides no direct instructions for how to actually do this.

It is impossible to calculate or design according only to «Technical Regulations». That is why all the «Technical Regulations» have in their appendices the lists of old regulation documents. Designing according to them, like it is told, provides the fulfilment of demands, mentioned in «Technical Regulations». There are two of these lists in «Technical Regulations» for structures. One is mandatory, and another one is voluntary. Mandatory list should be considered in any way. Voluntary one is for reference only, but it is meant to help in fulfilling the demands of «Technical Regulations».

To the construction industry Federal Law №384 from 30th of December 2009 brought already mentioned document called **Technical Regulation «On safety of buildings and structures»**. It took effect from 1 of July 2010. Like it was told above it featured two lists of old regulation documents – mandatory and

voluntary ones. It was mentioned also that other «Technical Regulations» cannot contradict the Technical Regulation «On safety of buildings and structures». Also from the text of Federal Law №384 it follows that the old regulation documents in the lists from Technical Regulations have to be updated due to 1st of July 2012.

Not much really changed, but now it is not obligatory to design according to old SNiPs and GOSTs that are not mentioned in the mandatory list. If the task is different then it is allowed to do whatever taking into account only the safety demands of «Technical Regulations».

Concerning the scaffolding systems, Technical Regulation «On safety of buildings and structures» contains a reference to SNiP 12-03-2001 «Work safety in construction. Part 1. General requirements. Chapter 7.4.1-7.4.40». There are some requirements for usage of scaffolding systems that must be followed.

Two more regulation documents that deal with scaffoldings are: POT R M-012-2000 «Intersectoral Work at Height Safety Rules» and RD 34.03.204 «Safety Rules for Works with Tools and Devices». They contain quite similar information and it is a little bit wider than in SNiP 12-03-2001.

In the voluntary list of regulation documents from Technical Regulation «On safety of buildings and structures» there is also one about scaffolds, called GOST 27321-87 «Demountable tubular scaffold for constructional work». This document is mostly for manufacturers and it deals only with two types of scaffolding systems: «tube and coupler» and very old «pinned» type.

Federal Law in Draft №192544-5 called **Technical Regulation «On safety of building materials, products and constructions»** is adopted at the first reading. The final list of constructions that will be subject to this regulation is in the stage of development and quite short now. Scaffolding systems are not mentioned yet. Time will show if they appear there or not.

One more thing to mention is that while there are GOSTs and SNIPs, which are not in the mandatory list of Technical Regulation «On safety of buildings and structures», some of them may still be in power. It can happen in cases when they are referenced from other normative documents. So it is important to check this all the time.

POT R M-012-2000 «Intersectoral Work at Height Safety Rules» is generally very independent document that deals with safety during any works at height in construction, industry and other fields. Its status cannot be lowered by Technical Regulation.

Chapter 2.2.2 of POT R M-012-2000 says that scaffolds have to comply with requirements of two GOSTs: GOST 24258-88 «Different types of scaffolding. General specifications» and GOST 27321-87 «Demountable tubular scaffold for constructional work. Specifications».

GOST 27321-87 was mentioned previously as the one from the voluntary list of Technical Regulation. It contains information only about «tube and coupler» and «pinned» systems. But the first one - GOST 24258-88 deals with all types of scaffolding and contains general requirements for any system.

Being referred to in the active document means that the content of these GOSTs has to be followed. Generally, rules given in GOST 24258-88 are quite similar to ones in POT R M-012-2000 and they do not contradict each other. Taking into account that this GOST is quite old it is still active though. In addition to general requirements it gives valuable information about the documentation. In its appendices there is a strict form of scaffolding passport that must be provided by manufacturer. And also there is a form of «Journal of scaffold accounting». In POT R M-012-2000 it is called «Journal of acceptance and visual examination of scaffolding», but generally it is the same. Concerning that POT R M-012-2000 is more up-to-date document, the term «Journal of acceptance and visual examination of scaffolding» is widely used right now.

The common form of the journal is presented in the Appendix 2.

8.2 Documents to carry about when performing assembly of scaffolding

When using the scaffolding, some special documentation has to be prepared, according to present regulation system. These documents are listed below.

1. Order, which assigns a committee responsible for acceptance of scaffolding.

Copies of the order are kept by the director of works and at the work safety service.

2. Handover certificate

And adequate handover procedure for transferring control of the scaffold from the erector to the user is an important part of managing scaffolding safety. Both the scaffold erector and the user should be satisfied that the scaffold can provide a safe working platform and can carry the designed loads safely.

Scaffolding that is more than 4 m in height can be used only after it is accepted by committee, assigned by a person, responsible for work safety in a company (or general director himself) and after preparing a handover certificate. (SNiP 12-03-2001, § 7.4.14; POT R M-012-2000, § 2.2.40).

If scaffolding is assembled by subcontractor for its own use, then it is accepted by the committee assigned by the director of this subcontracting company or their site manager. In this case the committee is headed by the engineering worker from the same subcontracting company. (RD 34.03.204, § 5.2.20).

If scaffolding is assembled by energy enterprise (energy industry) itself or it is assembled by subcontracting company (that performs repairs, construction works or any other) for the needs of energy enterprise then the scaffolding is accepted by the committee assigned by the order inside the energy enterprise. It is headed by the engineering worker from the same energy enterprise. There are also representatives from every subcontracting company, workers from which will be using this scaffolding. (RD 34.03.204, § 5.2.20).

The handover certificate is approved by the head engineer (technical director) of the company that performs the acceptance. (POT R M-012-2000, § 2.2.39; RD 34.03.204, § 5.2.20).

When scaffolding is assembled by subcontractor to meet its own needs it is acceptable if the handover certificate is approved by subcontractor's site manager. (POT R M-012-2000, § 2.2.39; RD 34.03.204, § 5.2.20).

The main point here is that the person who approves the handover certificate cannot be a member of the committee.

During the acceptance of scaffolding it is checked that all the braces and connections that provide stability are in their places, decks and guard-rails are not broken, standards are vertical, supporting platforms are stable and there is a grounding made for metal scaffolding. (SNiP 12-03-2001 § 7.4.14; POT R M-012-2000, § 2.2.40; RD 34.03.204, § 5.2.21).

Before the approval of the handover certificate it is forbidden to use the scaffolding (POT R M-012-2000, § 2.2.39; RD 34.03.204, § 5.2.20). The common form of the scaffolding handover certificate is presented in the Appendix 3.

3. Journal of acceptance and visual examination of scaffolding.

Scaffolding that is below 4 m in height can be used right after it is accepted by superintendent or foreman with the note put into the journal of acceptance and visual examination of scaffolding (SNiP 12-03-2001 § 7.4.14; POT R M-012-2000, § 2.2.40; RD 34.03.204, § 5.2.21). If the scaffolding is more than 4 m in height then, like it was told above, handover certificate issued by the committee is required.

In building organisations all the scaffolds have to be visually examined every day right before use by the brigade leader who is going to use the exact scaffolding and no less than one time in ten days by work superintendent or

foreman. The results of the examination have to be put into the journal of acceptance and visual examination of scaffolding (POT R M-012-2000, § 2.2.41).

8.3 Demands applied to scaffolding

All the following requirements for scaffolding are applied by three main regulation documents already mentioned above. The main is the Technical Regulation «On safety of buildings and structures», which has a reference to SNiP 12-03-2001 «Work safety in construction. Part 1. General requirements. Chapter 7.4.1-7.4.40». The other two documents are POT R M-012-2000 «Intersectoral Work at Height Safety Rules» and RD 34.03.204 «Safety Rules for Works with Tools and Devices».

In this chapter the main safety demands applied to scaffolding are described. Concerning that these three documents contain quite similar information it was checked that they do not contradict each other or differ in any details.

It is necessary to say that there are different job titles mentioned in Russian regulation documents. To make a direct translation of them into English is almost impossible, because the whole system is different. That is why a special glossary was made to explain the hierarchy on building site and different responsibility levels. It can be found in Appendix 5.

Visual inspections of scaffolding have to be done regularly according to the manufacturer's manuals and also each time after a recess in usage, exposure to extreme weather or seismic conditions or other consequences that could affect structural strength and stability. If the works on the scaffolding were suspended, then right before the resumption of works the scaffolding is subject to acceptance once again. New handover certificate has to be made. If some failures or damages are found then they have to be fixed and after that another acceptance procedure is conducted.

The mass of one element to lift at once by one worker when using manual assembly of scaffolding must be no more than 25 kg if the assembly happens at height or no more than 50 kg if the assembly happens on the ground with following lifting and installation by the crane power.

Wooden decks and wooden guard-rails have to be treated by impregnating fire retardants. Nails in wooden elements are fully driven in or bended so that they can cause no harm.

Ground surface on which the scaffolding is installed has to be even. Otherwise, scaffolding must be equipped with adjustable base jacks to provide the horizontality of construction.

Scaffolds must not be attached to balconies or other hanging parts of the facade.

Loads must not be more than those mentioned in the scaffolding's manual or in the project. If more loads are needed to be applied then it has to be proved by calculation of strength and, if necessary, the scaffolding structure must be reinforced.

In the places of entrance to scaffolding there should be posters, which show the allowed layout of load placement and maximum values of loads. Also there should be emergency plans.

Metal scaffolds are produced from straight metal tubes, which have no dents, cracks or other defects that affect the strength of elements.

Only metal fasteners (couplers, bolts) can be used for scaffolding.

Tubes must not be cracked, have splits, be covered with corrosion or visually bended. Tube ends must be strictly perpendicular to their axes.

Steel scaffolding tubes and alloy ones cannot be mixed together in the same scaffolding structure.

Loads applied to decking must not exceed values permitted in the passport of scaffolding or in the project. Crowding in one spot of scaffolding is not allowed.

Decking must have flat and even surface. Gaps between the decks have to be less than 5 mm.

The scaffolding width to perform the brickwork must be no less than 2 m. For plastering works – 1,5 m. For painting works – 1,0 m. And there is an additional demand for decks used when doing plastering and painting. If there are other activities on the scaffolding under the level of plastering or painting or there is a walkway underneath, then the gaps between the decks are not allowed.

When putting the decking elements onto the bearing tubes, it should be checked that they cannot be easily displaced or shifted.

Under each pair of base plates in transversal direction should be put a wooden plank of one piece with thickness over 5 mm. It is put on the compacted and even ground surface. To make the plank lay even by using the fragments of broken planks or other scrap is not allowed.

When constructing the scaffolding of more than 6 m in height there should be more than two levels of decking: working (top) and guard (bottom) and each working place on the scaffolding adjoined to the building facade should be protected from above by one more decking.

To perform the works on several levels simultaneously along the same vertical line without intermediate guard decking between the levels is not allowed.

The distance between the staircases, used for convenient access to the scaffolding, must be less than 40 m. If the whole scaffolding structure is less

than 40 m in length then it must be equipped with two staircases at the least. The pitch of staircase must not exceed 60° to the horizontal surface.

If the scaffolding is installed close to the driveways then the gap between the scaffolding and the vehicles should be more than 0,6 m.

The height of the scaffolding is measured from the ground level, floor or platform on which it is installed.

Decks and staircases have to be cleaned periodically during the works and after their completion. In the winter time the snow and ice is needed to be removed and the sanding to be done.

It is not allowed to work from the random props such as boxes or barrels when being on the scaffolding.

Both assembling and disassembling of the scaffolding must be conducted in the exact sequence like it is indicated in the manufacturer's manuals. Workers involved into the process must be instructed about the methods and sequence of assembling and disassembling and about the safety measures. It is forbidden for persons not involved in the process to access the place of assembling and disassembling of scaffolding during the process.

It is not allowed to install metal scaffolding closer than 5 m to the wires of district electricity lines. Otherwise, during the processes of assembling and disassembling of scaffolding, the electricity power has to be cut off and the wires earthed. Or the wires themselves have to be sheathed or dismantled.

During works at height the walkways beneath the scaffolding must be closed and the hazardous area bordered and marked with safety signs. If the scaffolding intersects the entrances to the building, then they must be equipped with solid safety canopy to protect people from falling objects. Safety canopy is tilted in the direction of scaffolding at the 20° angle.

If the constant human traffic is needed to be organized close to the scaffolding then the walkway must be equipped with continuous safety canopy and facade of the scaffolding is covered with protective mesh. The size of the mesh cell has to be no more than 5x5 mm.

The gap between the wall of the building or industrial equipment and the decking of the scaffolding cannot exceed 50 mm when doing brickwork and 150 mm during the other works.

When performing the insulation works the gap between the surface that is being isolated and the decking must not be more than double thickness of the insulation plus 50 mm. Gaps more than 50 mm must be covered in every case when the works are not conducted.

It is not allowed to disassemble the scaffolding partially and leaving them for conducting works without taking care of additional safety measures.

When using factory-made scaffolding it is necessary to do everything according to manufacturer's manuals. In addition to that, elements of different types of scaffolding cannot be combined. Factory-made scaffolds must be equipped with fastening elements that provide stiffness to the whole scaffolding structure.

Scaffolding systems be only be used the way they were originally intended. Organization performs technical supervision to ensure that.

During the lifting of heavy loads onto the scaffolding or moving them along the decking, it is necessary to avoid harsh hits against structural elements of scaffolding.

Loads should be distributed as evenly as possible.

During the lifting of loads onto the scaffolding it is necessary to use an additional rigging rope to prevent harsh hits against structural elements of scaffolding.

Scaffolding must not be used as the storage for materials. There must be only those materials that are currently used.

Works on the outside scaffolds have to be stopped in case of stormy weather with a speed of wind of more than 15 m/s, heavy snowfall, fog, icing of ground surface or other conditions hazardous to health of workers.

During the disassembling of scaffolding constructed alongside the building, all the doorways of the first floor and balcony exits of every floor are closed within the area of disassembling.

Scaffolding structures that have their decking at height more than 1,3 m above the floor or the ground must be equipped with guard-rails. Height of guard-railing must be no less than 1,1 m. Vertical distance between the horizontal elements of guard-railing – no more than 0,5 m. Height of toe-board – no less than 0,15 m.

There are also special requirements when using mobile scaffolding. Slope of a surface on which the mobile scaffolding is being moved in transversal and longitudinal directions must not exceed the values, mentioned in manufacturer's manual for specific scaffolding structure.

Moving of mobile scaffolding is not allowed if the wind speed is more than 10 metres per second. Before moving the scaffolding it must be free of materials and material containers. No people allowed on moving scaffolding.

Each caster or wheel of mobile scaffolding must have a locking device.

Access gates in the guard-railing of mobile scaffolding must open inwards and have a locking device that protects them from spontaneous opening.

There is a poster in Appendix 1 that visually describes the most principal requirements for scaffolding in Russia among above-mentioned in this chapter.

9 COMPARISON OF RUSSIAN AND FINNISH SAFETY REQUIREMENTS FOR SCAFFOLDING

The Finnish and the Russian legislation both state that initially after the assemblage of scaffolding it must be inspected and accepted for use. Special attention here is paid to the load-bearing and guarding elements. If the scaffolding was not used for quite a long period of time or after the heavy rains, winds and other extreme weather conditions the whole structure has to be checked very carefully once again.

Later on, during the works it has to be inspected at least once in 10 days in building organizations according to Russian law. In Finnish law it is told that during construction works the scaffolding must be checked at least once a week.

In Finnish law it is said so that the results of inspection have to be recorded somehow. In Russian regulations there is a standardized form of a journal that should be filled by a superintendent (Appendix 2) and it is told also that after the initial inspection the handover certificate has to be made.

There is nothing special mentioned in Russian regulations about how to restrict the access to the scaffolding that is not finished or has not passed the inspection because of failures or damages. The note is put by superintendent into the journal and normally the scaffolding is restricted by the safety tape so that everybody is informed about the prohibition of access (Figure 46).



Figure 46 Safety tape

Safety tape that indicates danger is usually red or red and white striped one.

In Finland there is also no strict rule about how to close the scaffolding from access if it is not finished or needs to be repaired. It is told that there has to be just some kind of indicator showing that it is not allowed to enter the scaffolding.

One way which is becoming more and more popular in Finland is scaffolding tagging system «TELINEKORTTI» (Scaffolding card). It consists of safety tag inserts and plastic holders which are showed on the Figure 1.1. The insert is green coloured and being inside the holder it covers up the red-coloured restrictive marking. On the insert itself there are the text fields provided to be filled with the information about the last check. So if the insert was put into the holder the green background is easily noticeable and the access is allowed. The acceptable level of load is also mentioned there. But if there is no insert inside the holder then the red restrictive signs are clearly visible. Also the insert itself can be double-sided. If it is turned green the access is allowed, and if it is red – not. And instead of being red from one side it can be yellow, showing that the scaffolding is not finished yet. But the principle is quite the same in each case.

Initially this system of tagging was invented in United Kingdom by Scafftag Ltd and nowadays is constantly gaining popularity all over the world. Their classic scaffolding tag is shown on Figure 47.



Figure 47 Scaffolding tagging system

The scaffolding tag commonly used in Finland is shown on Figure 48 below. It is green-sided meaning that the access to scaffolding is not restricted and containing all information about the last inspection.



Figure 48 A closer look at the Finnish scaffolding tag

It is a good thing to use such kind of a scaffolding card – the same one everywhere. Standardised way of informing is always useful, being well-known for everyone who enters the construction site.

In Finnish law the gap between the wall and the decking of the scaffolding have to be less than 250 mm. Otherwise the additional protective railing/falling protection from the side which is close to the wall has to be installed. According

to Russian law the gap must be even less wide – the maximum width is 50 mm when doing brickwork and 150 mm for other works.

By Russian legislation scaffolding structures that have their work level at height more than 1,3 m above the floor or the ground must be equipped with guard-rails. In Finnish law the maximum acceptable height without the guard-rails is bigger being 2,0 m above the ground.

Minimum height of the guard-railing is 1,0 m in Finland and in Russia it is 1,1 m. Maximum vertical distance between the horizontal elements of guard-rails is 0,5 in both of the laws.

By Finnish regulations the guard-rails have to sustain the point load of 1,0 kN elastically (without plastic deformation). In Russian norms it is a little bit less being 0,7 kN.

Both laws require the information about load-bearing capacity of scaffolding to be put at places, where it can be easily visible. Russian legislation states that such posters should be put near the entrances to scaffolding. In Finland this information is usually provided by the above mentioned scaffolding tags.

The demands for mobile scaffolding are quite similar in both countries. Wheels and casters must be equipped with lockers that restrain the scaffold from moving during the works. It is not allowed to move the mobile scaffolding with people on it.

Both laws are highly concerned on safety of scaffolding works. Some figures are different, but generally they are quite similar. It is told everywhere in Finnish law, that the scaffolding must be safe. For example, even it is mentioned that the height without guard-railing can be up to two metres, it should be wisely observed and if there is a high risk of stumbling and falling down, then it is better to care about this.

10 WORK SAFETY IN PRACTICE

It is a common practice in every construction company being it Finnish or Russian to check the work site safety all the time. In ARME OY this procedure is called “Safety Walk”. Usually participants from the company (superintendents and safety managers or safety director) are presented as well as participants on behalf of the customer. During the safety walk a lot of things are inspected and notes are taken. For example: condition of walkways, organisation and cleanliness, materials storage, waste management, protection equipment, lifting devices, scaffolding inspections (scaffolding tags and the overall condition of scaffold structures) and so on. Finally the report, containing the list of faults and things that require attention is formed, the person in charge of fixing them is assigned and the due date is specified. Things that have to be fixed are described more detailed below the list. Common work site safety walk-around report used in ARME OY is presented in Appendix 4.

During the safety walk-around everything that needs fixing and taking care of was found and put into this report.

Figure 49 shows the lack of starter elements of scaffolding. Installation of them is required by the manufacturer’s manuals.

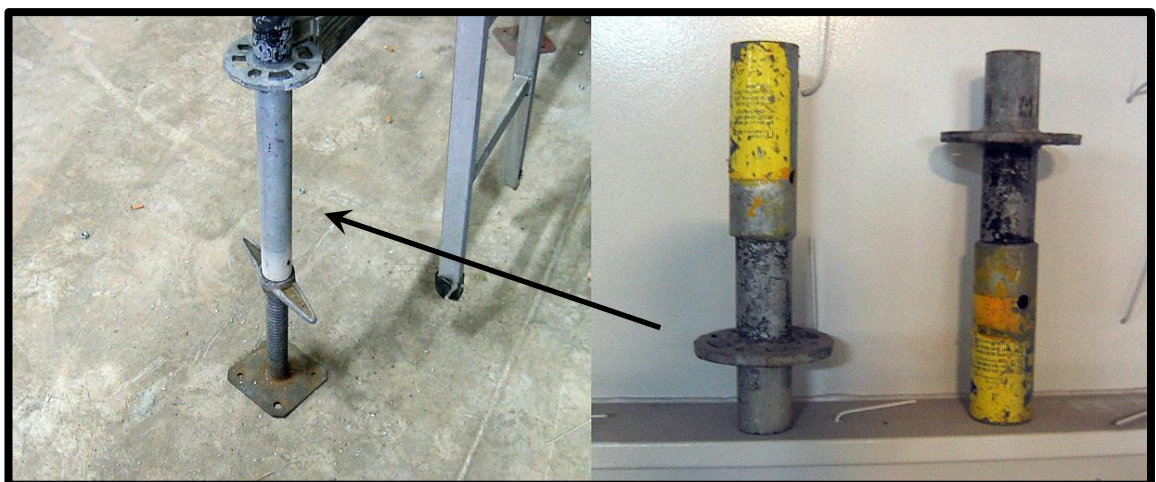

Figure 49 Starter elements missing

Not only the situation with scaffolding is checked during the safety walk but the whole condition of work site. Figure 50 shows the place that needs some tidying up. Unused decks and elements should be stacked, not just left here and there.



Figure 50 Additional cleaning required

On figure 51 there is an opening on the staircase, which is quite big and hazardous, because easily lets someone to fall down into it.

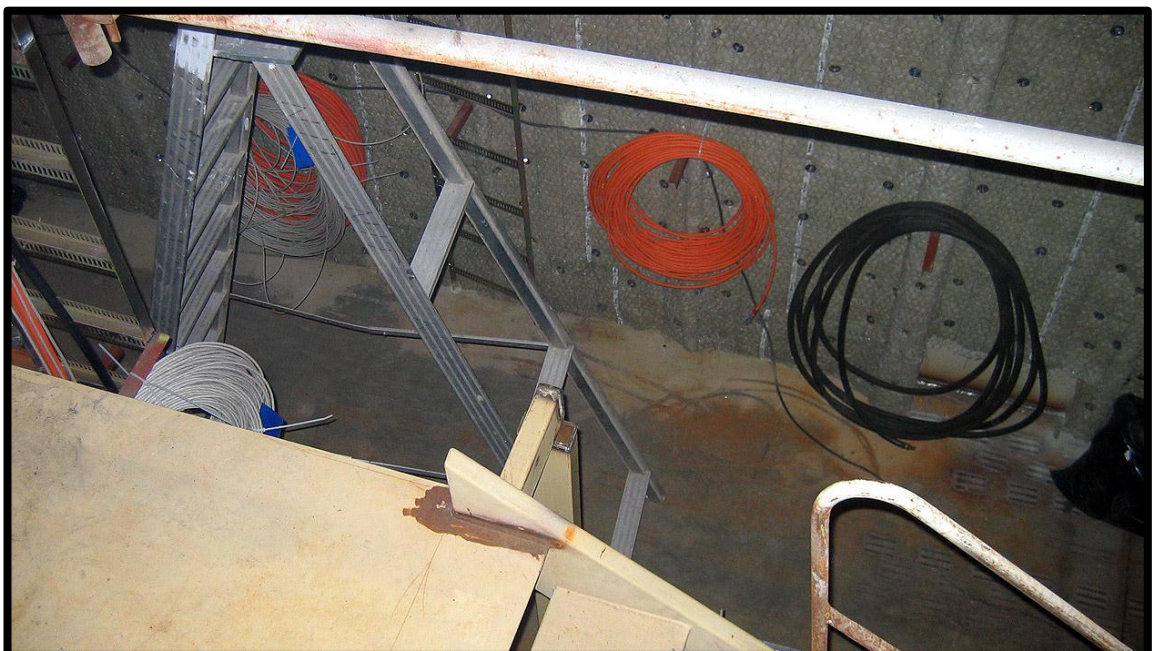

Figure 51 Too large opening left on the staircase

The most serious problem found was the damage of scaffolding structure illustrated on Figure 52. It has undergone quite serious deformations caused by

outer impact from some kind of machinery like forklifts or other vehicles which operated with carelessness and hit the scaffolding.

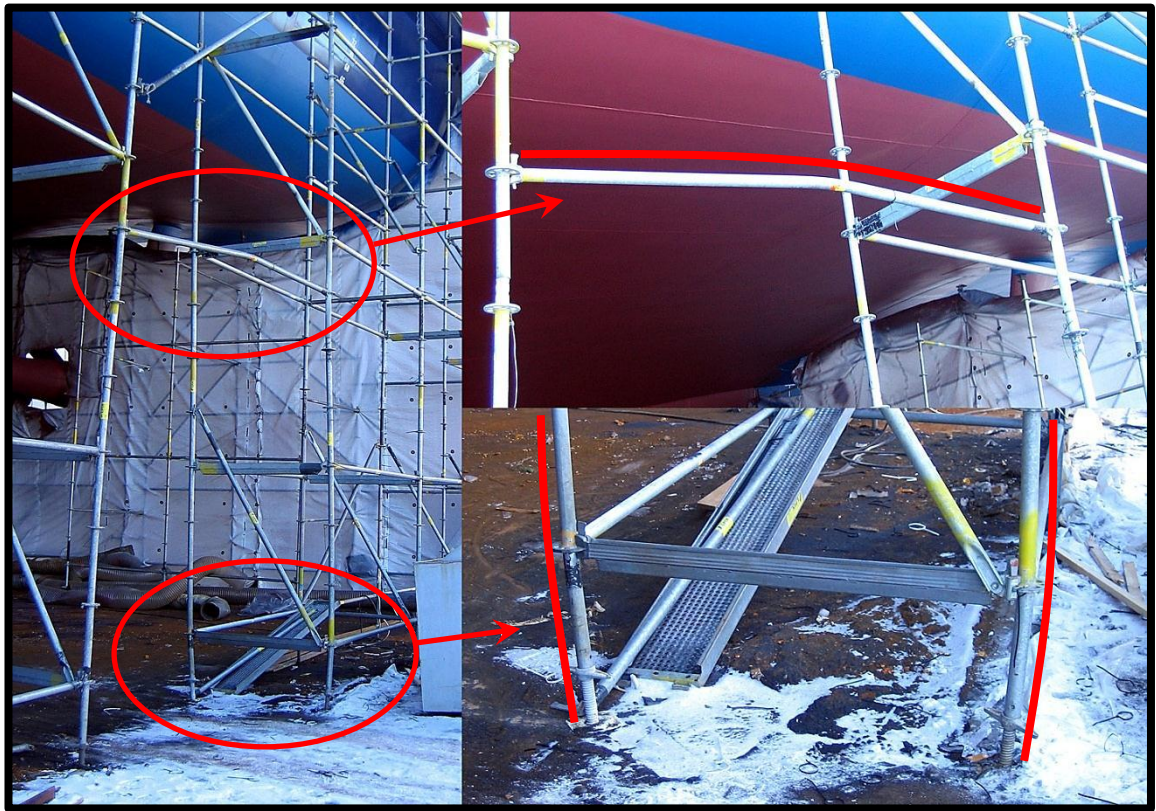

Figure 52 Bending of ledgers and standards

The dismantling process needs to be performed with special care and all the damaged parts of scaffolding, which suffered from bending, have to be disposed and never used again.

It is a company rule that all the damaged elements have to be cut in two parts right after dismantling so that nobody will be able to use them in future.

11 SUMMARY

Main goal of the study was to compare scaffolding systems that are used nowadays in Finland and in Russia. This included scaffolding material itself and differences in legislation between these two countries.

Regarding the scaffolding material it is obvious that Russian-made scaffolding is one step behind the German. First, the approach to presenting the products varies quite much. It is not easy to get specific information from Russian manufacturers, since they try to save their design from stealing. That caused difficulties when gathering data for comparison. At the same time, German manufacturers provide their products with open catalogues of characteristics and technical information.

When comparing the systems themselves it becomes clear that Russian manufacturers have not reached the European level yet, but this mostly comes from the demand. Building companies are trying to get the cheapest offers possible. The price is usually the main thing to consider. This is the main reason for the fact that foreign systems are used on Russian building sites very seldom.

Anyway the constant development of Russian scaffolding is noticeable. Some manufacturers are trying to improve their systems, bringing innovative ideas to design of their joints or to production process.

The Russian legislation base is constantly changing. The attempts to simplify the system and make it more up-to-date sometimes bring contradictions between the existing documents. In this thesis work all the documents, which deal with scaffolding were analysed and information from them was sorted out to make all the requirements transparent and understandable. As a result, similarities and differences between Russian and Finnish law were found.

During the work with thesis it was discovered that it is not easy to explain some features of Russian construction field, for example, job titles on Russian building

sites. There are quite many of them, unlike in Europe. And it was significant to explain each work title, its level of responsibility and job description, because they are mentioned quite often in legislation documents.

It was planned so that in the end of this study it would be possible to say if there are opportunities for European scaffolding companies to do business on Russian market with foreign scaffolding systems. The answer is definitely "YES". Although, the prices are much higher, the advantages of higher-quality products are slowly becoming to be realized. It is now already possible to meet German scaffolding on major construction sites in Russia, even though it is not a common practice yet.

Such expansion of higher-quality systems will definitely push Russian manufacturers to improve their products. And from the work safety point of view it is the step forward, because scaffolding itself ever stays to be a business of a very high risk.

FIGURES

Figure 1 Modular scaffolding - renovation of the Landwasser Viaduct in Switzerland

Figure 2 Scheme of scaffolding materials and their treatment

Figure 3 Scratch consequences on zinc-coated and painted metal pieces

Figure 4 Bamboo high-rise scaffolding in Hong Kong, China

Figure 5 Scaffolding failure in San Francisco caused by stormy winds

Figure 6 Main elements of scaffolding

Figure 7 Scaffolding dimensioning terms

Figure 8 Guardrails and toe-boards

Figure 9 Cup-Lock joint principle

Figure 10 Wedge driving stages of Ring-Lock modular scaffolding system

Figure 11 Ring-Lock joint principle

Figure 12 Angle adjustment scheme

Figure 13 Ledgers, transoms and diagonals in different lengths

Figure 14 Starter element

Figure 15 Tubes connected with Right Angle Rigid Couplers

Figure 16 Tubes connected with Swivel Couplers

Figure 17 «Tube-and-Coupler» scaffolding

Figure 18 Principal scheme of tubular welded frame scaffolding

Figure 19 Modern way of fastening the braces

Figure 20 Locking pin work principle

Figure 21 Fabricated frame mobile scaffolding

Figure 22 Modular mobile scaffold gantry in the tunnel, Australia

Figure 23 Plastic deformation of the ending of vertical standard by RINSTROY

Figure 24 Ring-Lock by RINSTROY, secured on tube by plastic deformation

Figure 25 Common spigot fitting with an additional inner tube

Figure 26 Common spigot fitting with additional screwed inner tube and welded Ring-Lock

Figure 27 Vertical standards with welded Ring-Locks by MDN-Prom

Figure 28 Spigot connection of standard

Figure 29 Development of Ring-Lock joint by MDN-Prom

Figure 30 Wooden decks laying upon the longitudinal ledgers

Figure 31 Strengthened horizontal element and long metal deck

Figure 32 Ring-Lock joint by MSK

Figure 33 Patented joint by SIMAN+

Figure 34 Bearing ring / Cup

Figure 35 Grip

Figure 36 Cone with a locking pin

Figure 37 «Star» joint by SIMAN+

Figure 38 Connection of elements to the «Star» joint

Figure 39 Scaffolding by Rinstroy. Wooden decking.

Figure 40 Metal scaffolding deck

Figure 41 Wedge head by MDN-Prom (left) and fully casted wedge heads by RINSTROY, SIMAN+ and MSK (right)

Figure 42 Different types of ledgers and transoms by Alfix

Figure 43 Deck carried by U-shaped transom

Figure 44 Ring-Locks from left to right: Alfix, RINSTROY, MDN-Prom, SIMAN+

Figure 45 Wedge heads by Alfix (left) and SIMAN+ (right)

Figure 46 Safety tape

Figure 47 Scaffolding tagging system

Figure 48 A closer look at the Finnish scaffolding tag

Figure 49 Starter elements missing

Figure 50 Additional cleaning required

Figure 51 Too large opening left on the staircase

Figure 52 Bending of ledgers and standards

TABLES

Table 1 Main characteristics of the scaffolding system by RINSTROY

Table 2 Main characteristics of the scaffolding system by MDN-Prom

Table 3 Main characteristics of the scaffolding system by MSK

Table 4 Main characteristics of the scaffolding system by SIMAN+

Table 5 Load-bearing capacities of Russian scaffolding systems

Table 6 Widths of scaffolding available from Russian manufacturers

REFERENCES

Alfix Scaffolding System Modul PLUS II Catalogue.
<http://www.alfix.de/downloader/ModulPlusIIEnglisch.pdf>
(Accessed on 26 April 2011)

Federal Law №184 from 27th of December 2002. About Technical Regulations.

Federal Law №384 from 30th of December 2009. Technical Regulation
«On safety of buildings and structures».

Find Scaffolding website, 2011. Bamboo Scaffolding.
http://www.findscaffolding.com/bamboo_scaffolding.php
(Accessed on 26 April 2011)

GOST 24258-88, 1988. «Different types of scaffolding. General specifications».

GOST 27321-87, 1987. «Demountable tubular scaffold for constructional work. Specifications».

Health and Safety Authority of Ireland, 2008. Code of Practice for Access and Working Scaffolds.

Layher GmbH & Co. KG. Australian website. Mobile Scaffold Gantry in Tunnel.
<http://www.layher.com.au/scaffold/mobile-scaffold-gantry-tunnel.html>
(Accessed on 11 April 2011)

Levy, Sidney M. 2000. Construction building envelope and interior finishes databook. Section 3. Structural Steel, Joists and Metal Decking. USA: McGraw-Hill.

N.C. Department of Labor. Occupational Safety and Health Division, 2008.
A Guide To Safe Scaffolding. USA, North Carolina, Raleigh.

POT R M-012-2000, 2001. Intersectoral Work at Height Safety Rules.

RD 34.03.204, 1996. Safety Rules for Works with Tools and Devices.

SNiP 12-03-2001, 2001. Work safety in construction. Part 1. General requirements, paragraphs 7.4.1-7.4.40.

Sosiaali- ja terveysministeriön päätös (156/98), 1998. Työtelineiden ja putoamisen estävien suojarakenteiden käytöstä rakennustyössä. Helsinki.

RUSSIAN SCAFFOLDING ASSEMBLY AND USE POSTER

GUARD-RAILING

Handrail
Longitudinal element
TOE-BOARD
Decking

1,1 m
0,45 m
0,05 m
0,15 m

Pitch of staircases between levels must not exceed 60°

Put posters showing layout of load placement and maximum values of loads

SCAFFOLDING

Scaffolding below 4 m in height can be used right after it is accepted by **superintendent or foreman**, while the one that is **more than 4 m in height** - by **committee**, assigned by general director himself. In building organisations all the scaffolds have to be visually examined **every 10 days** by work **superintendent or foreman**.

Lightning conductor 3,5 m

Do not overload!

Watch the reliability of anchorage

To climb up only use the stairs

Ground surface is compacted and made even. Use of bricks, stones or wedges is **PROHIBITED!**

Plank thickness no less than 0,05 m

3 m

GROUNDING IS OBLIGATORY.
Resistance: no more than 10 Om

LOW-RISE SCAFFOLDING

IF THE LEVEL OF DECKING IS HIGHER THAN 1,3 m ABOVE THE GROUND THEN THE SCAFFOLDING STRUCTURE MUST BE EQUIPPED WITH GUARD-RAILS AND TOE-BOARDS

no less than 0,15 m
no less than 0,05 m
1,1 m
no less than 1,1 m
more than 1,3 m

SECURELY FASTEN THE JACKS OF MOVABLE SCAFFOLDING

OBSERVE THE WIDTH

no less than

2 m brickwork
1,5 m plastering
1 m painting

Gap cannot exceed

0,05 m brickwork
0,15 m other works

AT HEIGHT OF MORE THAN 6 m IT IS ALLOWED TO WORK ONLY WITH TWO GUARD LEVELS OF DECKING

Top guard decking
Work level
Bottom guard decking

SCAFFOLDING HANDOVER CERTIFICATE

APPROVAL

Site manager
(responsible site supervisor)

(signature) _____
(Initials, Surname)
« ____ » _____ 20 ____

SCAFFOLDING HANDOVER CERTIFICATE

« ____ » _____ 20 ____

(work site)

Committee:

chairman of the committee: _____
(Initials, Surname)

members of the committee: _____
(Initials, Surname)

(Initials, Surname)

(Initials, Surname)

performed inspection of scaffolding _____
(short description of scaffolding)

assembled _____
(place of assemblage)

_____,
and came to conclusion that the scaffolding mentioned above meets all work safety requirements and valid for use.

Chairman of the committee: _____
(signature) _____
(Initials, Surname)

Members of the committee: _____
(signature) _____
(Initials, Surname)

(signature) _____
(Initials, Surname)

(signature) _____
(Initials, Surname)

WORK SITE SAFETY WALK AROUND REPORT



Work site safety walk-around

No/date: 14.02.11

Proj no 7040

Work site: RAUMA SHIPYARD

Object of inspection	OK	Must be fixed	Person in charge	Fixed date	Object of inspection	OK	Must be fixed	Person in charge	Fixed date
1. Work site traffic	✓				19. Electrical equipment, cords	✓			
2. Work site lighting	✓				20. Subcontracting	✓			
3. Organisation and cleanliness		✓			21. Familiarisation, done?	✓			
4. Hazardous substances	✓				22. Familiarisation documents	✓			
5. Flammable materials	✓				23. First aid readiness	✓			
6. Noise and vibration	✓				24. Fire protection		✓		
7. Materials lifting and moving, storage	✓				25. Work permits, blueprints	✓			
8. Waste management	✓				26. Personal protection	✓			
9. Hand tools	✓				27. Work site atmosphere	✓			
10. Machines (wringers, guillotine cutters, bordering machines etc.)	✓				28. Customer documents (risk evaluation etc.)	✓			
11. Welding work and equipment	✓								
13. Lifting equipment	✓				29. Customer feedback	✓			
14. Vehicle lifters	✓								
15. Lifting devices	✓								
16. Scaffolding		✓							
17. Scaffolding inspections	✓								
18. Work site access ways	✓								
19. Environmental safety	✓								

MORE DETAILED INFORMATION ON OBJECTS REQUIRING RECTIFICATION

NUMBER DETAILS

3	Outdoor walkways are a little bit slippery. Additional cleaning is needed at some places. Too big hole/opening left uncovered on the right side of a stairway, which can cause a fall down accident.
16	Starting parts of scaffolds are missing here and there. Scaffolding structure has suffered deformations caused by outer impact.
24	Cover against fire is missing on plastic packages with insulation material.
	Detailed photos are put into the appendix according to present numbering system.

SIGNATURES

Employer representative

Valerii Viunov

Employee representative

JOB TITLES ON RUSSIAN BUILDING SITES

There are a lot of job titles on building sites in Russia. Their descriptions and responsibilities vary greatly from one company to another. However, it is possible to describe the most commonly used hierarchy.

Site manager (Superintendent) – "Nachal'nik ychastka"

Site manager is the person in charge of everything on the whole construction site or the part of it. He is a key player in the performance of the schedule and the coordination of all activities on the site. He is the head of all the superintendents.

Superintendent (Assistant superintendent or Area superintendent) – "Prorab"

The term "Prorab" comes from the combination of two words: PROizvoditel' RABot (Manager of works).

Superintendent is the principle manager of works. On large projects different superintendents may be used to control different segments of work. All the labour, including engineering workers are subordinate to superintendent. Superintendent gives instructions to workers through foremen.

Foreman – "Master"

Foreman is the head of all the labour and the direct manager of works in a particular work area of the construction site. He is subordinate to superintendent. Foreman is responsible for the quality of work produced by workers. He does not perform the actual work with tools.

These were completely managerial positions.

Brigade leader – "Brigadir"

Brigade leader is the head of a brigade or workers. He **is actually performing the work with tools** and at the same time spending some time to control its crew. Brigade leader is assigned by the general director of the organization (according to nomination by superintendent) from the most qualified workers, who possess

organizational skills. In huge brigades, brigade leader can be free from performing the work with tools.

Specialized brigade – "Spetsializirovannaja brigada" – up to 25-30 workers.

Consists of several work teams, which perform the same work task (concreting, plastering, brickwork)

Complex brigade – "Kompleksnaja brigada" – up to 50 workers.

Consists of several work teams, which perform different work tasks that go simultaneously. For example, complex brigade of concrete workers: formwork assemblers, reinforcement workers, concrete pourers.

Work team leader – "Zven'jevoj"

Work team leader is the head of a work team. He is assigned by the general director of the organization (according to nomination by Brigade leader or Foreman) from the most skilled workers.