

Productization of a Low NO_x Wood Dust Burner System in a Power Boiler

Based on Andritz's wood dust burner implemented in SCA Östrand Mill in Sweden

Petri Kilpeläinen

Bachelor's thesis

Koulutusala Tekniikan ja liikenteen ala			
Koulutusohjelma Kone- ja tuotantotekniikka			
Työn tekijä(t) Petri Kilpeläinen			
Työn nimi Low NO _x puupöly polttimen käyttö voimakattilassa ja sen tuotteistaminen			
Päiväys	29.5.2012	Sivumäärä/Liitteet	70
Ohjaaja(t) Ritva Käyhkö			
Toimeksiantaja/Yhteistyökumppani(t) Andritz AG, Varkaus			
Tiivistelmä			
<p>Andritz Kraft and Paper Mill service osasto tutkii mahdollisuutta tuotteistaa puupölypoltin järjestelmä joka on rakennettu SCA Östrandin tehtaalle Ruotsiin.</p> <p>Tämän insinööriyön tavoitteena on selvittää, kuinka puupölypolttimet SCA Östrandin tehtaalla Ruotsissa toimivat ja kuinka ne on asennettu ja projektoitu osaksi vanhaa järjestelmää. Työn tarkoituksena on ottaa selvää mitä laitteita, turvallisuusjärjestelmiä ja muutoksia järjestelmään on tehty, jotta puupölypolttimet on saatu otettua käyttöön.</p> <p>Työssä selvitetään projektin lähtökohdat ja tavoitteet, mitä asiakas halusi ja mikä oli Andritzin ratkaisu. Työssä tutkitaan puupölyyn liittyviä taustatekijöitä, pelletin valmistus ja kuljetus, poltinteoriaa, päästöt, tarvittavat tehdyt muutokset ja turvallisuusjärjestelmät. Lisäksi työssä käsitellään tuotteistamisen teoriaa ja lopuksi kaikki tieto kerätään yhdeksi paketiksi.</p> <p>Opinnäytetyöstä tehdään kaksi versiota, julkinen ja Andritzin versio. Tästä versiosta jää pois varsinainen puupölypoltinten tuotteistaminen, sillä tieto on luottamuksellista.</p>			
Avainsanat Tuotteistaminen, Puupölyn polttaminen, Poltin, Low NO _x , Voimakattila			

Field of Study Technology, Communication and Transport			
Degree Programme Mechanical Engineering			
Author(s) Petri Kilpeläinen			
Title of Thesis Productization of Low NO _x Wood Dust Burner System in Power Boiler			
Date	29.5.2012	Pages/Appendices	70
Supervisor(s) Ritva Käyhkö			
Client Organisation/Partners Andritz AG, Varkaus			
<p>Abstract</p> <p>Andritz Kraft and Paper Mill Services Department is looking for the possibility to productize the wood dust powder burner system implemented in SCA Östrand Mill Sweden.</p> <p>The goal of this thesis was to find out how wood dust burners at Östrand Mill were implemented and how the project was handled, how the new burner systems works and to gather information of the used equipment, safety related systems and modifications required by the existing system.</p> <p>In this thesis the background of the project, customer request and Andritz solution were studied. After this the basics of pellet transportation, storing, basics of this type of burners, emissions and regulations, modifications done to the existing system, burner controls, safety related systems. This thesis also covers the basics of productization and includes all information needed to the productization for this type of burners.</p> <p>There will be two versions of this thesis one for school and one for Andritz. In this version the part where these types of wood dust burners are productized is left out, since this information is confidential.</p>			
Keywords Productization, Wood dust, burning, Burner, Power boiler, Low NO _x			

Used symbols and abbreviations

Abbreviations:

SRS	Safety Related Systems
BFB	Bubbling Fluidized-Bed
Euro Combustion	Mexico based, burner and equipment manufacturer
SO ₃	Sulfur trioxide, a chemical compound of sulfur and oxygen
SO ₂	Sulfur dioxide, an oxide of sulfur
NO _x	Nitrogen oxides
Flue gas	Combustion exhaust gas produced by power plants
Torre faction	Roasting process to remove moisture from pellets
ATEX	EU directives concerning explosion safety of equipment and work environment
Pyrolysis	Heating process of the fuel without introducing oxygen to the process
DCS	Distributed control system, a broad term for system and sub-system control
FB	Fluidized bed, used to promote a high level contact between gases and solids

Foreword

This bachelor's thesis was made as an assignment to Andritz. I hope that my work is helpful for evaluating the possibility to productize this kind of wood dust burner system. My knowledge of this kind of burners will also be helpful in the future, working at Andritz.

I would like to thank all the people who helped me with this thesis and thank for this great opportunity given me. I would not have been able to do this without you.

I would like to especially thank Hans Barthelson, Project Leader, Andritz AB his help was crucial for this thesis to succeed. Most of the information of this project was from him or with his help.

Ari Korpirinne, Andritz Oy, Technical Sales Manager, Power boilers for supervising my thesis, helping me to understand this project better and help with the contents of this thesis.

Marko Airola, Andritz Oy, Service Engineer, for general help and for supervising the SRS section of the thesis.

Ritva Käyhkö, Savonia University of Applied Sciences, for general supervision and help.

Denny Sundqvist, SCA Graphic Sundsvall AB, Process Engineer, for providing all the information needed from SCA Östrand.

Erik Ågren, Andritz AB, Product Manager, Recovery and Power Boilers.

TABLE OF CONTENTS

1. Introduction	9
1.1 Background, customers requests	9
1.1.1 Andritz solution	9
1.2 Andritz AG	10
1.3 SCA Östrand	11
1.4 Project schedule	12
1.5 Savings and benefits, firing wood dust	13
2 Low Nox wood dust burner, power boiler solution	14
2.1 General information, dust handling and burner system at Östrand Mill	14
2.1.1 Wood dust station	16
2.1.2 Dust collector	17
2.1.3 Hydraulic conveyors	17
2.1.4 Pellet elevator	18
2.1.5 Screw transporter, to balance silo	19
2.1.6 Balance silo (buffer silo)	20
2.1.7 Dosing screws	21
2.1.8 Pellet crusher (Hammer Mill)	21
2.1.9 Cyclone filters 1, 2, 3, 4	22
2.1.10 Wood dust lines 1 and 2	23
2.1.11 Air blowers	24
2.1.12 Quality control	24
2.1.13 Wood dust silo (primary)	25
2.1.14 Dosing units, below the primary silo	26
2.1.15 Burners	27
2.2 Manufacturing of wood pellets	29
2.3 The risks of transport and storing of wood pellets, chips and timber in a confined space	31
3 General Low NO _x burner theory	33
3.1 Oil burning	33
3.1.1 Dispersing steam burner	34
3.1.2 Emissions of oil burning and emission control	35
3.1.3 Sulfurtrioxide and dioxide, SO ₃ and SO ₂	35

3.1.4 Nitrogen oxides, NO _x	35
3.2 Theory of firing wood and wood dust	36
3.3 Flue gas emissions of wood dust burning and emission control (mainly thermal NO _x).....	38
4 Modifications required by the boiler system in SCA Östrand Mill Sweden	40
4.1 A new dual-fired burner system	40
4.1.1 Burner openings.....	41
4.1.2 Flame detectors	43
4.1.3 Refractory and panel work	43
4.2 Burner controls.....	45
4.3 Boiler controls	45
4.4 Combustion air system modification	46
4.4.1 Combustion air pressure	46
4.4.2 Primary air.....	47
4.5 Load controls	48
4.5.1 Wood dust control.....	50
4.5.2 Oil flow control	51
4.5.3 Transportation speed for wood dust	51
4.5.4 Changing the fuel from oil to wood dust.....	51
4.5.5 Changing fuel from wood dust to oil	52
4.5.6 Trimming Oxygen O ₂	53
5 Safety related systems (SRS)	54
5.1 Design conditions	56
5.1.1 Measuring acceptable explosion safety.....	56
5.1.2 Dust explosion	57
5.2 Safety and control systems for burners.....	57
6 From technical innovation to productized offerings.....	59
6.1 Productization	59
6.1.1 Inbound productization.....	60
6.1.2 Outbound productization.....	62
7 Summery	63
8 REFERENCES	65

APPENDICES

Capital1: PI-schema Wood dust station area 1

Capital2: PI-schema Wood dust station area 2

Capital3: PI-schema Wood dust station area 3

1. Introduction

In this thesis the background of the burner system implementation are studied, customers requests and solutions delivered by Andritz Oy. After this we'll study basics of pellet transportation, storing, basics of this type of burners, emissions and regulations, modifications required by the existing system, burner controls, safety related systems and the basic productization theory for these type of burners.

1.1 Background, customers requests

Andritz AB received an order to replace six Euro Combustions burners in boiler AP1 SCA Östrand. The old burners were replaced with four oil/wood dust burners. Three of the new burners are fired with fine wood dust and oil, while one of the burners will only be fired with oil. All four burners have the capability to be co-fired with wood dust and oil. This was all part of a bigger order to add a new lime kiln to SCA Östrand Mill.

1.1.1 Andritz solution

Andritz prepared two solutions, with one was to replace the requested three oil-fired burners with two combined wood dust and oil burners, 30MW/burner, with accessories. Option two was to replace all six current oil-fired burners with four co-fired wood dust burners. Option two was then the one that was chosen to be implemented to the existing system.

Andritz Oy's Scope, products included

- Hydraulic Conveyors (Stokers for Pellets)
- Pellet Elevator
- Pellets silo
- Screw Conveyors
- Dosing units (to Hammer Mill)
- Pellet crushers (Hammer Mills)
- Cyclone Filters
- Feeders
- Blowers(for Wood Dust)
- Wood Powder dosing system

Andritz Low NOx wood dust powder burner solution, implemented at Östrand consists of

- 4 x Combined wood dust and oil burners as load burners
- New panel with furnace openings
- Air ducting and primary air fan for burners
- 4 x Oil station
- Platforms
- Demolition, erection and commissioning

SCA Östrand Mill Sweden, Scope of delivery

- Safety related systems
- Dust control
- Quality control
- Electrical work & Instruments
- Automation
- Civil Works

1.2 Andritz AG

Andritz Ag is an Austrian plant engineering group the headquarters of the group is located in Graz, Austria, with 16,750 employees stationed worldwide. Andritz Ag it is a globally leading supplier of plants, equipment, and services for:

- Hydropower stations, Andritz hydro
- Solid/liquid separation in the municipal and industrial sectors, Andritz separation
- Steel industry, Andritz metals
- Production of animal feed and biomass pellets, Andritz feed & bio fuel
- Pulp and paper industry, Andritz pulp and paper:

ANDRITZ Oy is a leading global supplier of systems, equipment and services for the pulp and paper industry including wood processing, fiber processing, chemical recovery, biomass power boilers and stock preparation. The total sales of the company are about EUR 300 Million. The number of employees is 1000. The headquarters are located in Helsinki, Finland. (Andritz.com, 2012)

1.3 SCA Östrand

The SCA Östrand Mill produces 425,000 tons of chlorine free bleached Kraft pulp. Nearly half is used in SCA's own production and manufacturing of publication paper, hygiene products and the remaining is sold to external customers. Östrand mill also produces 95,000 tons of chemical thermo mechanical pulp for hygiene, packaging and other products. Östrand mill also produces special pulp grades that are used to adapt properties to publication papers and tissue products. (SCA.com)

“Östrand is quality-certified in accordance ISO 9001 and environmentally certified in accordance with ISO 14001 and energy certified according to EN 16001.” (SCA.com) Östrand mill can also produce FSC-certified pulp. SCA Östrand mill produces 500 GWh of green energy per year, with the soda recovery boiler that started operating in 2006. Östrand mill is self-sufficient in both electricity and heat thanks to the soda recovery boiler. The investment was worth SEK 1.6 billion. SCA Östrand has 380 employees. Figure 1 demonstrates the bio loop process of the SCA Östrand mill. (SCA.com)

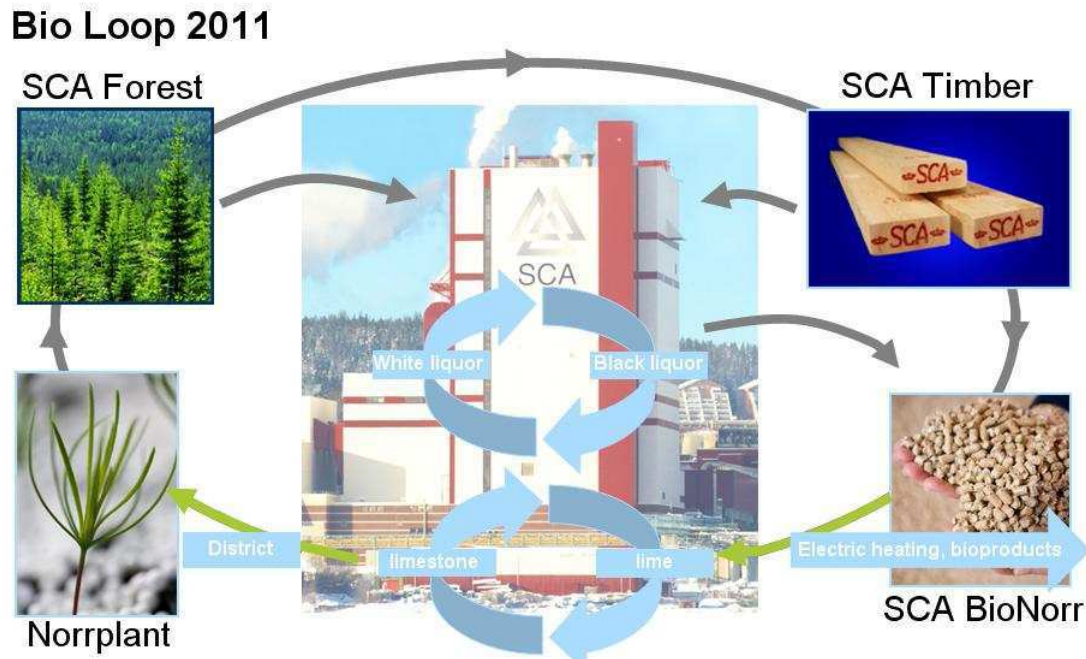

Figure 1. Bioloop 2011, SCA Östrand

1.4 Project schedule

Start of the project	April 2010
Bark Boiler AP1 replace wall panels of 6 oil burners to 4 dual Burners for wood dust / oil	Start September 2010
Reception pellets / grinding to wood dust	Start May 2011
Wood dust transport storage	Start May 2011
Wood dust dosing and combustion	PB1 May 2011 3 lines Lime kiln October / November 2011
Trials completed, system handed	November 2011

1.5 Savings and benefits, firing wood dust

Östrand Mill uses their own pellets that they transport to the Mill from SCA BioNorr. The savings burning wood dust instead of oil are roughly 40-50%. Investments to the new burner system are estimated to pay for themselves in a few years.

While the costs of burner operations are reduced considerably, the NO_x and CO₂ emissions are also significantly decreased in comparison to firing with heavy oils. All this work is towards a more greener and more emission free working environment. More information about emissions and how to decrease them in general in Low NO_x burner theory part of this thesis.

2 Low Nox wood dust burner, power boiler solution

SCA Östrand pellet heating plant utilizes a solution that combines pulverized combustion technology with oil burning. The pellet fuel is pulverized in separate grinding Mills and burned in dual fired wood dust powder burners. Start-up and load control of the combustion process is remarkable and the use of pulverized fuel allows for clean, energy efficient heat generation. Dual fired wood dust and oil burner technology is relatively new and has been utilized in Sweden on a smaller scale before.

2.1 General information, dust handling and burner system at Östrand Mill

It all starts with pellets. Pellets are delivered six to eight times a day to Östrand Mills wood dust handling station. Inside the station pellets are then dumped to pellet receiving pocket from which they are transferred in to a buffer silo with the help of pellet elevator and screw conveyors.

In buffer silo the pellet flow is measured to match the amount of dust used by the burner system in the area 3 (see figure 2). Pellets are transferred from buffer silo to crushers 1 & 2 with two transferring lines.

Pellets are then crushed into fine wood dust. Before the wood dust can be transferred to the main wood dust silo the dust will go through cyclone filters, before and after going through dust lines connecting area 2 and area 3. Wood dust controls everything related to wood dust in areas 1, 2 and 3. For more information see figure 2 below.

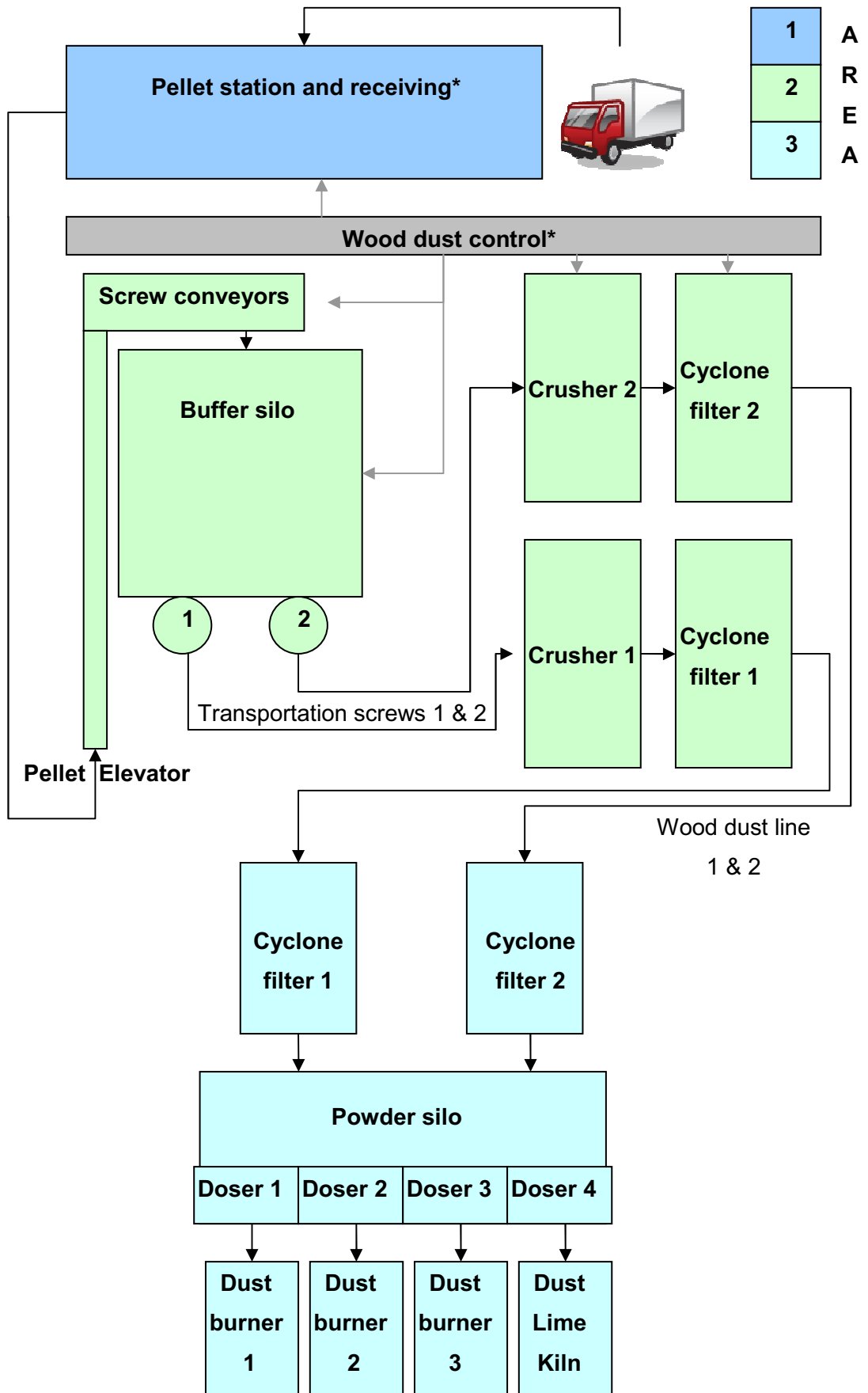

Figure 2. General Östrand wood dust handling information (*implemented by SCA)

2.1.1 Wood dust station

25 t/h worth of wood dust is delivered to the wood dust station as pellets. The pellets are delivered to the station by trucks six to eight times a day. The station has two wood dust transportation lines installed with the working capacity set to 11 t/h per line. 11 t/h of wood dust is delivered to the lime kiln and the rest is used for the new burner system. Wood dust station can be seen in figure 3. Check appendices 1 & 2 for more detailed information of wood dust station and equipment.



Figure 3. Wood dust Station (New)

Pellets are brought in through the red door (figure 4) transported by a truck. Pellets are then dropped to the wood dust station floor in to a dump pocket. From where they are transferred to the buffer silo and pellet crushers by the pellet elevator and screw conveyors.



Figure 4. Wood dust station, inside

2.1.2 Dust collector

Because of the movement energy, that comes from dipping the wood dust and pellets to the floor of the wood dust station, a dust collector is set up to collect any dust that would be otherwise scattered all around the wood dust station. Dust collection system has three basic steps to it, which are to capture, convey and collect. Dust must be captured first. Conveying the dust is done with ducting system. Maintaining constant minimum air velocity is required to keep the dust in suspension for conveyance to the collection device.



Figure 5. Dust collector

2.1.3 Hydraulic conveyors

Conveyors are there to ensure that pellets get to the pellet elevator and in to the stations circulation system. (figure 7) The dump pocket inside the wood dust station has two hydraulic conveyors installed (figure 6). The conveyors will move the pellets towards a screw that is located in the center of the dump pocket, from where the pellets continue their way towards the pellet elevator.



Figure 6. Hydraulic conveyors

2.1.4 Pellet elevator

The elevator used to transport pellets (figure 7) to the balance silo located in upper floor is by design a bucket elevator by Monsum lachenmeier. Dust is conveyed to the pellet elevator with the use of feeding screws.

Since the screw conveyors can be affected by explosion pressure, the elevator has the cap of the conveyors strengthened. Inspection hatch at screws end can withstand 0.6bar without permanent deformation. (Jansson. 2011, page. 2)

The screw is always filled-up with material which minimizes risks of a possible explosion spreading backwards into the dump pocket. (Jansson. 2011, page. 2)

The elevator consists of:

1. The bucket for holding the pellets
2. A belt to carry and transmit the buckets
3. Means to drive the belt
4. Accessories for loading the buckets or picking material, for receiving the discharged material, for maintaining the belt tension and for enclosing and protecting the elevator.



Figure 7. Pellet elevator

2.1.5 Screw transporter, to balance silo

The screw transporter is located after the pellet elevator. Screw transporters function is the transportation of pellets from the pellet elevator to balance silo. Check figure 2 and Appendix 1 for more information.

2.1.6 Balance silo (buffer silo)

The balance silo (figure 8) balances the amount of pellets going to crushers 1 and 2 and therefore the flow of wood dust to the actual silo. Pellets are conveyed to the buffer silo with screw conveyors coming from pellet elevator.

The design of the elevator is based on "Explosion venting of bucket elevators" By Holdrow, GA Lunn. The strength of the elevator structure is verified to exceed the necessary value by far. (Jansson. 2011, page. 2)

To ensure the safety of the lift, the ignition source is fitted with temperature sensors that initiate alarm if the temperature rises to 60 °C and will stop the elevator if the temperature rises to 90 °C. On the stoppage, conveyors are set to upstream, to ensure that explosion does not go downstream into the pellet dump pocket. The lift is equipped with flash suppressors and hydraulic relief surface of 300x500 mm risks of possible explosion in the lift area are reduced mainly to steam and pressure shocks. (Göran Jansson. 2011, page. 2)

Explosion relief devices are arranged so that no one working in the lift area is exposed to danger zone. Ladder in the lift is the only exception to this since it's designed for checking and for replacing the explosion relief devices if needed. The ladder is equipped with warnings and accessing it is prohibited during operation. (Jansson. 2011, page. 2)

Pellets are crushed using champion crusher (figure 9) that is placed below the buffer silo. After the pellets are crushed to wood dust, the dust is transferred through the wood dust line to the main silo (figure 13). Output from the buffer silo is handled by double screws located at the bottom of the silo. During normal operation the screws are filled with material that minimizes the risk of explosion spreading downstream. Explosion is even more minimized since tube trays are located outside of silo. (Jansson. 2011, page. 2)

The balance silo is equipped with flash suppressors and an explosion relief system, located at the top of the silo. The silo is designed to withstand an explosion pressure of 0.8 bar. Explosion relief area can withstand a maximum pressure of 0.5 bar. Relief is directed out of the room to a location where no one is exposed to it during normal operation time. The room where the relief is directed can withstand the redirected

relief in relation to the flash suppressors unloading state, at least 15-fold. (Jansson. 2011, page. 2)



Figure 8. Balance silo

2.1.7 Dosing screws

Pellet output from the balance silo is handled by two dosing screws (figure 2, appendix 1). Dosing screws handle the amount of pellets going to crushers 1 and 2 through wood dust lines 1 and 2.

2.1.8 Pellet crusher (Hammer Mill)

Crusher (figure 9) is the machine designed to crush pellets into fine wood dust. The dust is then moved to buffer silo through wood dust lines 1 and 2. Champion crusher or hammer Mill is very good for grinding products like saw dust and wood chips and it's used very commonly for fuel purposes.

Champion hammer mill has been designed to withstand heavy load and stress that grinding tough and fibrous biomass material does to the hammer. Mass of the ham-

mer is designed to absorb vibrations and is thus very resistant to wear. (CPM Europe, 2012)

Air to the hammer Mill is used to reduce dead air space in the hammer Mill's housing. This is to reduce contamination risks and to improve the efficiency of the air flow. Basically a hammer Mill is a steel drum containing a vertical or horizontal rotating shaft on which hammers are mounted. Hammers can freely swing to the ends of the cross, or they can be fixed to a central rotor. The used material is then hit by the hammer bars and is shredded and expelled through screens inside the drum. (CPM Europe, 2012)



Figure 9. Crusher, (Hammer Mill)

2.1.9 Cyclone filters 1, 2, 3, 4

Cyclone filters are placed right before and after the wood dust lines 1 and 2, dust will have to go through the filters before entering or exiting the dust lines. Filters 1 and 2 are located right after crushers 1 & 2 (figure 2, appendix 2). Cyclone filters 3 & 4 (figure 2, appendix 2) are located at the top of the primary silo. (Andritz Feed & Bio fuel A/S, Cyclone Filter manual, page.4)

Cyclone filters installed are bag filters and designed for dust collection in mind. The filter housing is circular which makes it very suitable on places with varying pressure conditions. The filters are designed to be easily strengthened and operated during over or under pressure. The round filter housing makes it suitable to filter large amounts of dust, even without collectors. (Andritz Feed & Bio fuel A/S, Cyclone Filter manual, page. 4)

The filters are supplied with:

- Build-in module which consists of automatic filter head, bags and pod holders for installation to silos or supplementing the customer.
- Supplementary module is designed to be mounted into air blown silos or similar Milling plants
- Standalone filter with tangential inlet located either at the top or at the bottom, with a dust outlet through the cone.
- Above the filters "wide body" is a tangential inlet for dust. Dust extraction takes place through the bottom of the filter or by scraping the bottom. (Andritz Feed & Bio fuel A/S, Cyclone Filter manual, s.4)

2.1.10 Wood dust lines 1 and 2

Wood dust lines 1 and 2 are used to transfer wood dust from the dust station to the primary silo, located next door. A wood dust sample from the dust line can be seen in figure 10.



Figure 10. Wood dust from the wood dust line

2.1.11 Air blowers

Air flow to the crushers and to wood dust lines 1 and 2 is handled by two Robusch air blowers (figure 11). Four of the similar blowers are used later in the new burner system.



Figure 11. Air blowers

2.1.12 Quality control

Quality control is where wood dust and pellets are checked by hand to ensure the quality of the fuel used in three dual fired wood dust / oil burners and in the lime kiln.

Lime Kiln restricts the wood dust burned in all burners to white wood dust. This is to ensure the continuous and safe operation of the lime kiln and to make sure that no unwanted chemicals are introduced to lime kiln's circulation. Lime kiln can be seen in figure 17.



Figure 12. Quality control

2.1.13 Wood dust silo (primary)

Primary silo for wood dust (see appendix 3), the building on the left is the wood dust station (figure 13) and pipes coming from there are for transferring the wood dust to the silo. From the silo the wood dust is then transferred to burners and to the lime kiln.

Primary silo is equipped with explosion reliefs located on the top of the silo. Silo can withstand a pressure of 0.35 bar, the explosion relief area is estimated to withstand 0.34 bar. Venting filter is located on the top and can withstand a pressure of 0.35bar. (Jansson. 2011, page. 4)

Due to the fact that the possibility of flame spreading down the cone is almost impossible, (As stated in EN 14491) the probability of explosion going downstream is very minimal. During normal operation the cone is always filled all the way up to cylindrical parts. Outside of the explosion relief devices there is a danger zone of Lf 60 metre and for Wf = 18.5 metre diameter (Jansson. 2011, page. 4)



Figure 13. Primary silo

2.1.14 Dosing units, below the primary silo

The dosing system (wood dust dispensers) is provided with left and right-handed screws that rotate doses together. Dosing units regulate the amount of wood dust going into the burners 1, 3, 4 and lime kiln (figure 17). (Tomal Metering Systems, 2007, page. 3)

These screws can be used to create a block between the screws by rotating the screws in opposing directions. This ensures that screws are volumetrically accurate and self-cleaning. This also ensures that material coming from the silo on top of the dosing units is fed into the dosing system in a steady flow and spread. The output curve is straight and this means that each turn will dispense the same amount of chemicals. (Tomal Metering Systems, 2007, page. 3)

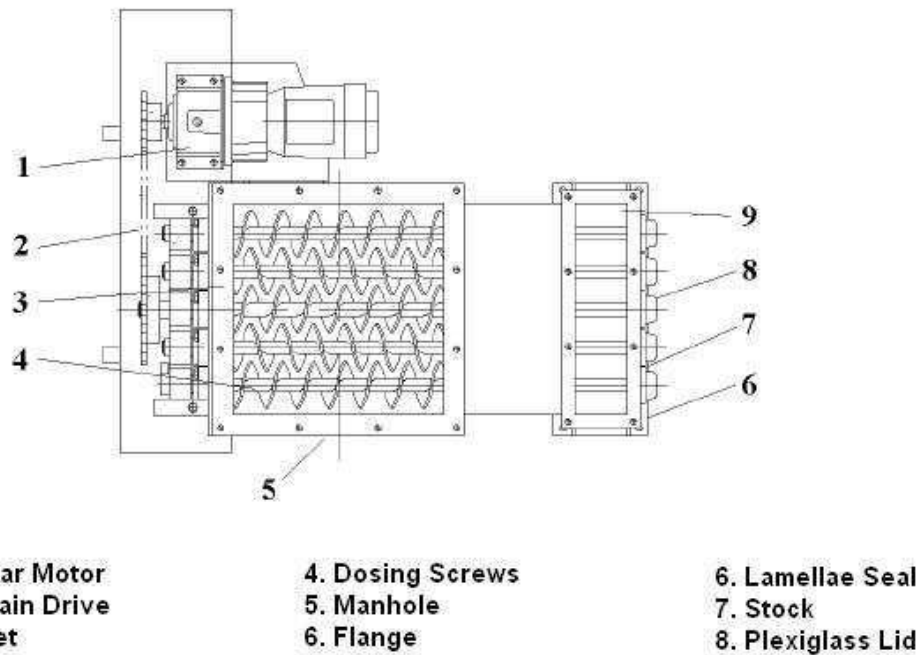

Figure 14. Dosing unit, wood dust dispenser

Before the outlet, feed screws dose the chemical through the exit tunnel. The dosing units can be equipped with lamellae seals that protect the bearings from the chemicals. The screws are mounted on the batch receivers. (Tomal Metering Systems, 2007, page. 3)

2.1.15 Burners

The Östrand Mill is fitted with four new dual-fired wood dust and oil burners (figure 15 and 16), each with 25 MW output for wood dust and 30 MW for oil. The burners can be fired with wood dust or other powdered fuel of the suitable particle size, with liquid fuels, either alone or co-fired. (Jacek Gromulski, 2010, page. 1)



Figure 15. Burners, before installation



Figure 16. Burners, installed



Figure 17. Lime kiln

2.2 Manufacturing of wood pellets

Wood pellets are made mainly of sawdust, wood chips and shavings – as a by product or as side product of wood and forest industry. In essence, the soft tree species, pine and spruce are used as raw material. (Anders Knutsson. 2011, page. 14)



Figure 18. Pellets

Some pellet qualities can be mixed with bark or peat. Although the use of pure peat pellet use is not rare. The manufacturing process differs between different factories, as the main principle is the same. The raw material is milled and dried to get an 8% moisture content. Shavings from the planing do not necessarily need further drying. (Anders Knutsson. 2011, page. 14)

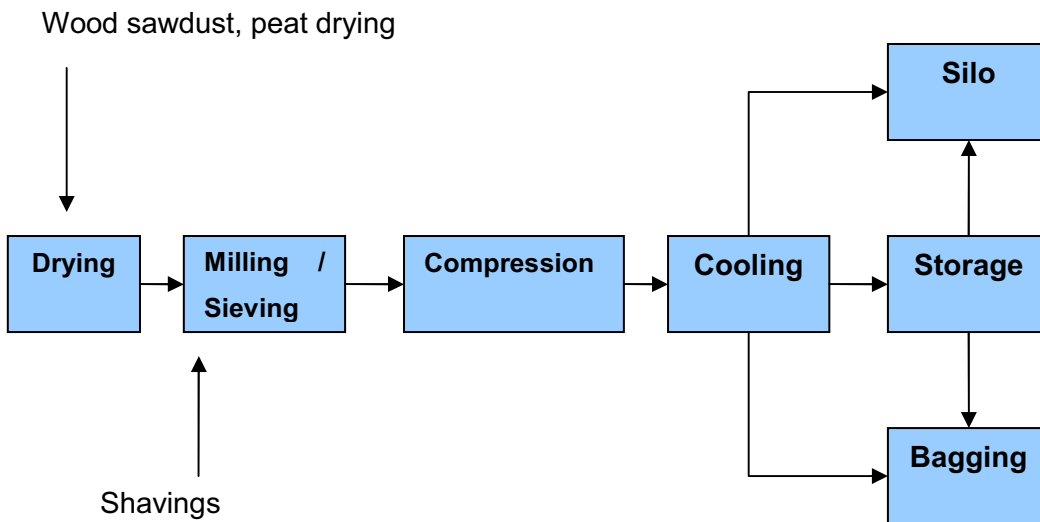

Figure 19. A simplified flow diagram of pellet manufacturing and storage.

After drying, the raw material is screened and then under high pressure compressed into pellets of 6 or 8 mm in diameter and 25-40 mm in length. The lignin in the woods melting process “glues” the pellet together and gives it the hard and shiny surface. (Anders Knutsson. 2011, page. 15)

The dry content percentage, allowed fraction, energy content and other physical parameters vary depending on quality classifications as specified in the Swedish Standard SS 18 71 20. A new Euro standard, EN 14961-2 will soon replace the former national standards. (www.cen.eu) (Anders Knutsson. 2011, page. 15)

The pellets are then packaged in small sacks of 16.25 kg, and into bigger bags of 600-650 kg (1m³) or stored loose in a large storage in silos or factories, from which the pellets are moved to customers by a truck. Approximately 40 % of global production of pellets is transported short or long distances in a cargo ship. (Anders Knutsson. 2011, page. 15)

There is an ongoing work to improve the products properties, for example with adding additives to the pellet composition. There is also an ongoing development work involving Torre faction, in order to increase specific the energy content of pellets. (Anders Knutsson. 2011, page. 15)

2.3 The risks of transport and storing of wood pellets, chips and timber in a confined space

Transporting and storing wood chips and timber in a confined space has not received the attention it deserves. Thirteen people have died since 2002 in accidents related to the storing of wood chips, pellets and timber. Most accidents occurred in a stairwell next to cargo holds in ships, but five people were killed after cargo had been passed into the destined country. (Anders Knutsson. 2011, page. 6)

In November 2010 in Ireland a person died in a smaller house storage. In February 2011, a pregnant woman died in a storage room in Switzerland. When storing wood pellets in a closed space, the pellets start to consume oxygen and toxic gases, carbon monoxide and carbon dioxides start to form and they are accumulated into dangerous to concentrations. (Anders Knutsson. 2011, page. 6)

Pellets store carbon monoxide (CO) and this is what poses the highest danger. For the storage of wood chips and logs, hypoxia in combination with elevated levels of carbon dioxide (CO₂) is the biggest risk. Carbon monoxide is produced by incomplete oxidation of the wood components. Irritant aldehydes, especially hexanal, formed into fresh pellets by oxidation of fatty acids can pose health and safety problems with storage. (Anders Knutsson. 2011, page. 6)

Dusting is a common problem in the mechanical handling of pellets. Dust irritates the respiratory tract and eyes, but it can also cause skin problems from resin acids. Respirator particle filters and full clothing can be used to protect against dust. (Anders Knutsson. 2011, page. 6)

Determining whether any danger exists, the active measuring of carbon monoxide and oxygen is inevitable. Smaller storages are measured before anyone enters the storage and after being inside the storage room. A personal CO meter should be

worn at all times. In large pellet storages it can be justified to install permanent meters for carbon monoxide.

Neither oxygen, CO or CO₂ have any warning properties, you cannot just use normal breathing filters for protection. If you have to go into storage room with dangerous levels of CO or CO₂, you'll have to use proper air breathing equipment. (Anders Knutsson. 2011, page. 6)

For CO poisoning, prompt treatment is fresh air, oxygen and possibly the use of pressure chamber. The affected person should be subjected to periodic medical care, the occurrence of late neuro-psychotic symptoms is possible, usually within 1-3 weeks, but it could take longer. (Anders Knutsson. 2011, page. 6)

To reduce risks, all types of storages are ventilated well before going into. Pellet storages (except for large silos) and floor storage should be built with natural ventilation and mechanical ventilation system as supplement when needed. (Anders Knutsson. 2011, page. 6)

All storages are at risk for high levels of dangerous gases or oxygen deficiency and they should be provided with warning signs (of the risks). The entrance door and hatches should be latched or locked, so unauthorized persons do not knowingly or unknowingly get inside. While the vent is under way, opening doors and hatches are to be sealed off with a mechanical barrier, a rope, a chain or with Iron Gate equipped with warning about trespassing until the space is assessed as safe to enter. (Anders Knutsson. 2011, page. 6)

3 General Low NO_x burner theory

Idea of Low NO_x burner is to greatly reduce NO_x emissions that are created especially at bigger factories and power plants. Nitrogen oxides are formed in a two different ways, from the fuels own contained nitrogen and from nitrogen released of from high temperature combustion air. Nitrogen oxides accelerate climate changes and cause breathing troubles especially for asthmatics and to small children. (Promaint, 2.2008), (Bloomengineering.com, 4.4.2012)

During the combustion process air and fuel injection is phased, this is to reduce the combustion temperature. Phasing allows down rating of the base flame, that has not enough air for complete combustion. This will allow the generation of carbonhydrogens that destroy the NO_x generated by the combustion process. (Promaint, 2.2008), (Bloomengineering.com, 4.4.2012)

3.1 Oil burning

Oil is used in variety of different applications of energy production, transportation and industrial processes. Oil is burned in a lot of different types of boilers and ovens, motors and gas turbines. (Asikainen. 2002, page. 439)

Handling oil before input to burner is very simple: pressure needs to be raised to match the used boilers specifications and while burning heavy oil, viscosity of the oil must be lowered and it is done by warming the oil. Purity of the oil must be verified with filters if needed. Heavy fuel oils even in room temperature are too rigid to handle, so the fluidity of the oil must be ensured by warming and circulating the oil. Primary criteria when picking the quality of the heavy oil are plant size and heat levels of the material used at heating the oil. (Asikainen, 2002, page. 439, 440)

For pre-treatment and burning most crucial features are viscosity, pour point and residue. Important features concerning emissions are sulphur-, nitrogen- and ash concentration. Variations in calorific values in different oil qualities are usually so small that it does not make any notable difference during burning. (Asikainen, 2002, page. 440)

Oil burner must achieve a stable and efficiently burning flame, which fits into the used furnace. (Asikainen, 2002, page. 440)

The primary functions of oil burner:

- decomposition of oil into tiny enough drops or gasification of oil
- ensuring ignition
- mixing of combustion air and oil drops
- minimizing emissions

(Asikainen, 2002, page. 440)

3.1.1 Dispersing steam burner

A lot of big oil boilers are equipped with steam dispersing burners. Dispersing steam burners are simple from structure reliable and can be used to burn a variety of different oils as fuel. Dispersion of oil is usually made with the help of slightly superheated steam. Saturated steam is used also, but this can cause risks concerning water droplets. (Asikainen, 2002, page. 444)

For dispersing to be efficient, steam- and oil spray would have to meet in a right angle and the steam should have sufficient kinetic energy. The burner will work either on steam pressure that is made constant or with sliding dispersed steams pressure in relation to work load. To achieve a wide control range, sliding of dispersed steam pressure is recommended. Then the difference of steam and oil pressure is held constant in the whole control area with the use of pressure control, for example so that steam pressure is 1.5-4 bar higher than oil pressure. Oil- and steam pressure ratio depends on drillings done to the nozzle. Steam pressure can be lower than oil pressure before going to burner. Oil pressure is usually around 5-20 bar the efficiency of dispersing depends largely on the amount of dispersed steam used. On full load new burner models, the needed dispersed steam is 2....5 % in relation to oil. While running on partial load the relative share of dispersed steam rises. Drawbacks of using dispersed steam are loss of heat and condensation. Steam is needed immediately at start up of the burner, which is produced for example with an auxiliary boiler. Compressed air can be used also during burner start up. The benefits of using dispersed steam burner are a wide control range and a minimal need for cleaning. (Asikainen, 2002, page. 444)

3.1.2 Emissions of oil burning and emission control

Many different key factors contribute to the amount of emissions during oil burning, like quality of oil, burner type, furnace dimensioning and running parameters, and specially air factor. Largely the same factors affect the gaseous emissions of oil burning. After this we'll go through the most significant key components and their side effects. (Asikainen, 2002, page. 446)

3.1.3 Sulfurtrioxide and dioxide, SO₃ and SO₂

Most of the fuels containing sulphur is oxidized to gaseous sulphur compounds such as sulphur dioxide and trioxide. The number of emissions can be most efficiently lowered by lowering the fuels sulphur concentration at oil refinery. Cutting sulphur emissions can also be done during or after burning if needed. Injecting alkali directly into the furnace has been tested with oil boilers, but the results of successfully lowering the sulphur concentration have been modest and the method has not become popular. Though, some experiences have been made with bigger oil boilers. (Asikainen, 2002, page. 446, 447)

3.1.4 Nitrogen oxides, NO_x

Mostly NO emissions are born during in known oil burning operations, from the nitrogen contained in the fuel and combustion air. Because of the high combustion temperature, the formation of N₂O is very low. With new Low- NO_x -burners, NO_x emissions in big heavy oil burners are usually around 100-150 mg/MJ and in comparison, in smaller light oil boilers the value is 50-100 mg/MJ. (Asikainen, 2002, page. 447)

Technical methods which are used to lower nitrogen oxide emissions during oil burning:

- Low- NO_x Burners (all)
- Flue gas, recirculation (all)
- Water-/Steam injection (gas turbines)
- Phasing of the combustion air to the combustion chamber (big boilers)
- Phasing of the fuel to the combustion chamber (big boilers)

(Asikainen, 2002, page. 447)

Most of the methods listed above can be applied to boilers of different sizes. Specifically the development of phasing the injection of fuel and air to the furnace has been focused on to bigger boilers. With heavy oil like fuels, the phasing of fuel into the furnace does not seem to be very promising. Other methods are commercially available. (Asikainen, 2002, page. 447)

The details of Low- NO_x –burners differ significantly by manufacturer, but key principles are all the same:

- Phased injection of combustion air and fuel
- Lowering the partial pressure of oxygen in critical NO_x formation zone
- To prevent the possibility of local temperature spikes

(Asikainen, 2002, page. 447)

Oil fuelled Low- NO_x –burners are primarily based on diffusion combustion and while burning the fuel rich base flame and air rich primary flame are visibly distinguishable. The total air ratio during burner operations depends on if the furnace phasing process is assisted with the use of upper air. With the use of internal or external circulation system flue gas circulation system can be included into the phased air burner system. With an internal circulation system the flue gas is circulated aerodynamically back into the base of the flame, straight from the furnace and in external circulation, the circulated gas will be taken from economizer or after air pre heaters. With existing boilers today, the implementation of external circulation is more than that of internal circulation system, since heat transference ability of a boiler changes because of the risen gas levels. (Asikainen, 2002, page. 447)

3.2 Theory of firing wood and wood dust

“Solid fuels contain both combustible and non-combustible components.” (Harald H. Welling, Thom J. Shaw, page. 29)

Non combustible components consist of ash and water. Lower ash content and higher volatility are the major differences between wood and coal burning. Wood moisture content (water) can vary greatly. Freshly harvested wood moisture content

is around 40-50 %. The moisture content of wood can be reduced to around 15-20 % with air-drying. (Harald H. Welling, page. 29)

A prerequisite to utilize wood as an environmental and desirable fuel is the complete and efficient combustion of wood and its components. The combustion process should ensure complete burn of the wood and therefore avoid the formation of undesirable compounds. Incomplete combustion can result in more emissions than wanted and these are normally caused by:

(John Vos, 2005, page. 8)

- Inadequate mixing of combustion air and fuel
- Lack of oxygen
- Low combustion temperatures
- Short residency of fuel
- Low concentration at final stages of combustion process

(John Vos, 2005, page. 8)

In cases when sufficient amount of oxygen is available, the most important factor is the temperature, because of its exponential influence on reaction rates. Therefore optimisation of these variables will greatly contribute to the reduction of emission levels. (John Vos, 2005, page. 8)

Approximately 80 % of energy comes from combusting gas and the rest from charcoal. It's very important to achieve a good contact between oxygen and woods combustible components during the mixing process of air and fuel. This is to ensure fast and complete combustion process. To achieve optimal mixing of the fuel and exact ratio, grinding of the wood to dust is necessary. Wood dust can follow the movement of air, and therefore a good mixture can be achieved. The combustion will resemble gas or oil flame. The firing technology for solid fuels and wood is more complicated than firing with gas or oil-fired systems. For optimal combustion, wood must go through three stages. (John Vos, 2005, page. 9)

- Drying
- Gasification and combustion
- Charcoal burnout

During the heating process water will evaporate from the surface of the wood. This will lead to gasification on the wood surface area. Heating the fuel without introduction of oxygen is called pyrolysis. The wood will then continue to heat and eventually water will evaporate from the interior of the wood. During the evaporation process, the pyrolysed area will further spread from the surface of the wood to inside. The gas released will ignite the fuel above to further increase evaporation and pyrolysis process. Combustion process is ongoing, as the gasified wood turns to charcoal, changed by oxygen until only ash is left of the wood. The larger the fuel particle is, the longer the combustion process will be. Small particles will dry more quickly, release gases and burn more effectively than bigger particles, this will result higher combustion intensity. Therefore the size of the fuel will greatly affect the speed of the combustion process. The dryer the used fuel is the more energy content the fuel has, since some of the energy produced by combustion will be used to evaporate the water content of the fuel. Overheating of the combustion chamber can occur when burning dry wood and heat should be drawn away from the chamber, before it can damage the equipment. Wet wood in the other hand will create a need to insulate the chamber to ensure that efficiency of the boiler will not drop and to enable a continuous combustion process. A typical way to accomplish this is to use refractory linings around the chamber walls, to conserve the generated heat. Boiler chambers are usually designed for certain moisture ranges for wood burning. If the wood moisture content that is used as fuel is more than 55-60 % of the total weight of the wood, ensuring the ongoing combustion process will be very difficult. (John Vos, 2005, page. 9)

3.3 Flue gas emissions of wood dust burning and emission control (mainly thermal NO_x)

Because the main emissions born from wood dust burning are thermal NO_x, lowering of these emissions must be taken into account when designing the burners. A variety of methods can be used to control thermal NO_x

- Burner design
- Exhaust or flue gas recirculation
- Using chemical additives (ammonia)

To prevent the formation of thermal NO_x the burner manufacturers have utilized low NO_x baffles, air staging and flue gas recirculation. Recirculation can be achieved by including products of combustion (POC) into the flame from the furnace or by using POC from the exhaust system to mix with air or fuel which reduces the temperature of the flame. Oxygen, which controls the reaction rate, is also diluted, reducing the probability that the available oxygen will enter to the NO_x generating reactions. Air tagging the controls flame temperature and the additive chemicals are fed to the burning environment to reduce NO_x formation. (www.Bloomengineering.com, 2012)

4 Modifications required by the boiler system in SCA Östrand Mill Sweden

The three euro combustion oil burners are replaced with four dual-fired wood dust and oil burners, each with a 25 MW output for wood dust and 30 MW for oil. The burners can be fired with wood dust or other powdered fuel which have suitable particle size, with liquid fuels, either alone or co-fired. (Jacek Gromulski, 2010, page. 1)

4.1 A new dual-fired burner system

Because of the limited efficiency of powdered fuel, the boiler geometry and dimensioning allows maximum power of 25 MW / h per burner. The dimension is limited in depth to 7.3 m. Flame length is over 8 m and width approximately 2.2 m in diameter. Same applies to oil burning also, when burning only oil the maximum load is 30 MW. (Jacek Gromulski, 2010, page. 4)

Co-firing is fully possible as long as the total effect of the burner does not exceed rated power. (Jacek Gromulski, 2010, page. 4)

Atomization of the oil is done with compressed air or steam. The required pressure of is 4-6 bar is achieved with the help of reducing valve from the existing system. The atomizing steam pressure should be 8 bar. (Jacek Gromulski, 2010, page. 4)

Each multi fuel burner consists of, as seen in figure 20:

- Oil Lance, atomization with compressed air / steam
 - Powder Lance
 - Ignition of the burner, propane
 - Primary air lance with registers
 - Secondary air duct with registers
 - Tertiary air duct with registers
 - Burners with motorized dampers
 - Burner nozzle, with ceramic channels for quaternary air
- (Jacek Gromulski, 2010, page. 4)

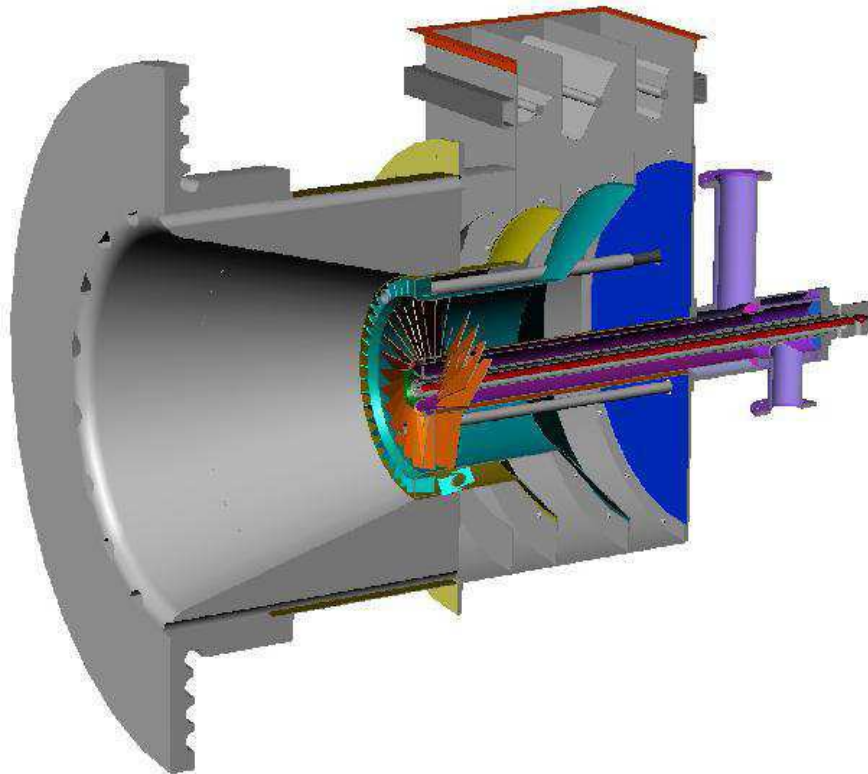

Figure 20. General structure of the multi fuel burner

To ensure stable ignition of the wood dust flame, the percentage of <math><0.2\text{ mm}</math> particle size powder must be 10 – 20 %. To ensure good burn-up ratio for wood dust the particle size will have to be <math><1.5\text{ mm}</math> and 90 % of the fuel used should be <math><0.6\text{ mm}</math>. Wood dust moisture content should stay <math><12\text{ \%}</math>. (Jacek Gromulski, 2010, page. 2)

4.1.1 Burner openings

New burner openings had to be installed before any new burner could be fitted into the existing system.



Figure 21. Burner openings



Figure 22. Burner Opening, from outside



Figure 23. Burner Openings, bended tubes

4.1.2 Flame detectors

All four burners are provided with flame sensors each. With dual detectors for UV (gas and oil-fired) and with an infrared detector for solid fuel heating, burner control and regulations are managed by a new control system (like the ABB 800-system) supplemented with an independent safety system (thing) to produce hard threaded monitoring especially of the critical functions. (Jacek Gromulski, 2010, page. 6)



Figure 24. Fireeye flame guard

4.1.3 Refractory and panel work

Refractories were made by Tecab Sweden AB (figure 25 and 26). Manufacturing, erection, panels, pass tubes and boxes for the burners were made by Novmar AB.



Figure 25. Refractory assembly, inside of the burner openings



Figure 26. Finalized refractory, seen from inside of the boiler

4.2 Burner controls

Wood dust burner is ignited with propane. The oil burners flame can be fired at full power with oil. Once the burners are fully operational with oil, the wood dust firing sequence can commence. Fuel change is done with phasing by controlling the amount of fuel coming in and out. Switching fuel from oil to wood dust or from wood dust to oil will take about 30-90 seconds depending on the load used. The ability to co-fire wood dust and oil has an added feature, during co-firing extra oil is produced. Burning this extra oil will restrict the oil flow to 25% if more oil needs to be burnt, one or more burners will need to be fired with oil alone. (Jacek Gromulski, 2012, page. 2)

4.3 Boiler controls

Since the boiler must be fired with bark, this in turn limits the dust used in other burners to white wood dust. The temperature of the bed must be monitored to prevent sintering of the fluidized bed (FB). Boiler start-up cannot commence before all boiler start up sequences are fulfilled. The following boot sequence is done assuming that the two existing combustion air fans are operating normally. (Jacek Gromulski, 2012, page. 2)

1. Start-up of the primary air fan
2. Starting airing
3. Airing completed all burner gates are closed, except the first few
4. Starting the burners, According to the selected start up sequence
5. Uploading
6. Loading

Fuel switching can commence once the burner is fully operational with oil. It is possible to change the fuel at burner operations manually. (Jacek Gromulski, 2012, page. 2)

4.4 Combustion air system modification

Combustion air to the new burners is handled by three air fans, two common combustion air fans and by a primary air fan serving all four burners. Primary air fan provides the air going to primary air register. When the air enters the combustion chamber a vacuum is created in the centre of the burner. The vacuum is created by high speed and heavy rotation is to keep the flame inside of the burner. (Jacek Gromulski, 2012, page. 3)

Primary air duct is placed in the same place as balancing dampers. Balancing damper opens and closes for each load to the burner. This ensures right pressure while working on different burner loads. The pressure transmitter ensures that right pressure is always used. Pressure transmitter will give out an alarm and stop the burners by interlocking with security systems if the primary air pressure goes too low. Primary air fan takes its air from combustion air fan. (Jacek Gromulski, 2012, page. 3)

Existing combustion air fans are used for the burners. For two burners the airflow and pressure is handled and recorded by the existing flow meters and pressure valve. (Jacek Gromulski, 2012, page. 3)

Design values for combustion air:

Air temperature	°C	30
Capacity	m ³ /h	150000
Pressure increase	kPa	4.5
Motor power	kW	360

4.4.1 Combustion air pressure

Existing combustion air fans [624FN0221 and 624FN0222] are used for burners. The combustion air pressure can be used to change the existing pressure on holding valve [624PC103] and pressure-maintaining valve [624PC105] going to burners 3 and 4. (Jacek Gromulski, 2012, page. 7)

The pressure of the combustion air regulated by a pressure regulator, reaching the desired value depends on burners last load (set point) Pressure regulator [624PC103 and 624PC105] provides pressure to the DCS system. If the pressure after dampers drops too low, the burners will be “hard” stopped by use of the pressure switch [PIZ]. Combustion air pressure from the combustion air blower will vary depending on the boiler load. (Jacek Gromulski, 2012, page. 7)

4.4.2 Primary air

The flow of primary air to each burner is measured. The air flow to the burners is distributed according to the following:

- Transport air for powder (constant flow) with blowers for fuel preparing. Frequency controlled.
- Primary air flow. Generated by a high pressure blower (booster) which is positioned adjacent to the total air fan. Primary air is used to get a dynamic and stable flame (Constant flow). Booster fan is common to both burners (frequency controlled). It takes its air from the total air fan.
- The secondary, tertiary, and quaternary air flows. This air is taken from total air fan. Partial flow is controlled by dampers.

Total Air Fan:

- Theoretical air requirement 52 000 m³ / h
- Design Flow 75 000 m³ / h at 30 °C
- Pressure composition 4.5 kPa
- Engine output 160 kW installed
- Average power (full load) 120 kW

Primary air fan (Booster):

- Design flow 6000 m³ / h at 30 °C
 - Final pressure air 10 kPa
 - Engine power 15 kW average 10 kW
- (Jacek Gromulski, 2010, s5)

4.5 Load controls

The burner can be controlled in several ways, manually or automatically, one fuel at a time or both simultaneously. In an auto controlled burner load, the selection and regulation of the fuel is done from the control screen. When the burner is fired using wood dust, oil can be fired simultaneously by just selecting oil from the screen. The amount of oil needed is shown on the oil controller. Only the chosen fuel can be set in auto mode. When the use of extra oil is selected, the oil controller cannot be set to auto mode. Air dampers are ratio curves, one curve for each gate and four curves total. (Jacek Gromulski, 2012, page. 8)

These curves can be adjusted from the control screen. Wood dust is normally never fired during single burner operation. (Jacek Gromulski, 2012, page. 8)

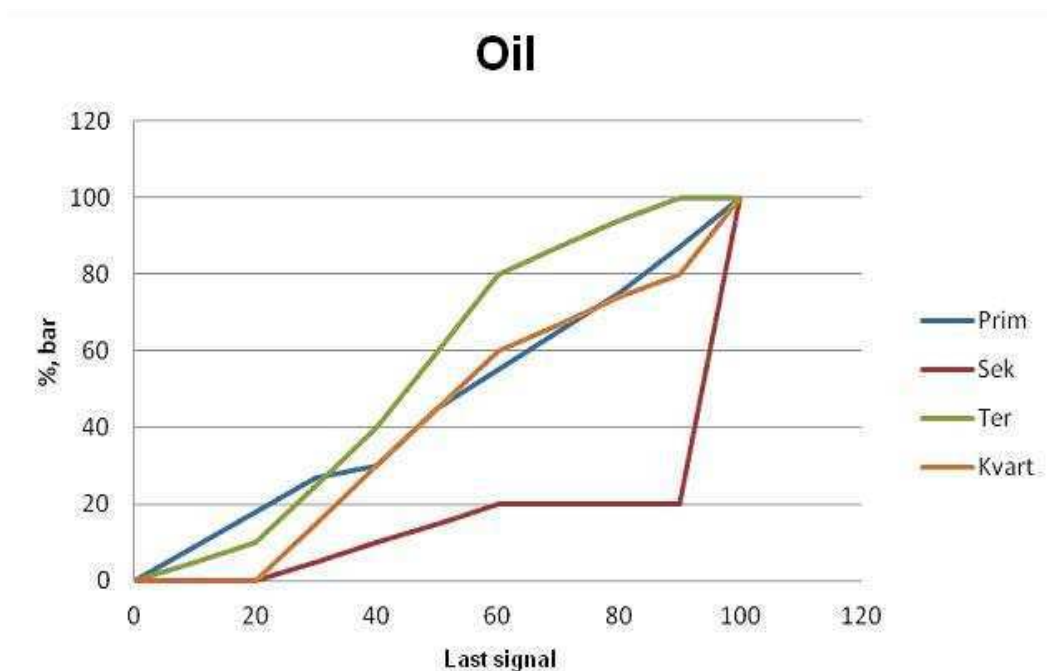

Figure 27. Load controls damper settings for oil operation

The total amount of fuel burned shall not exceed 100 %. 100 % of oil is 27 MW, 100 % of wood dust is 24 MW. Max power co-firing is 100 % i.e. 27 MW. This lets the oil regulator to go up to 100 % while the wood dust regulator can only reach 80 %. Choosing 10 % extra oil will limit wood dust output to 70 %. The total use of oil and wood dust should not exceed 100 %. (Jacek Gromulski, 2012, page. 8)

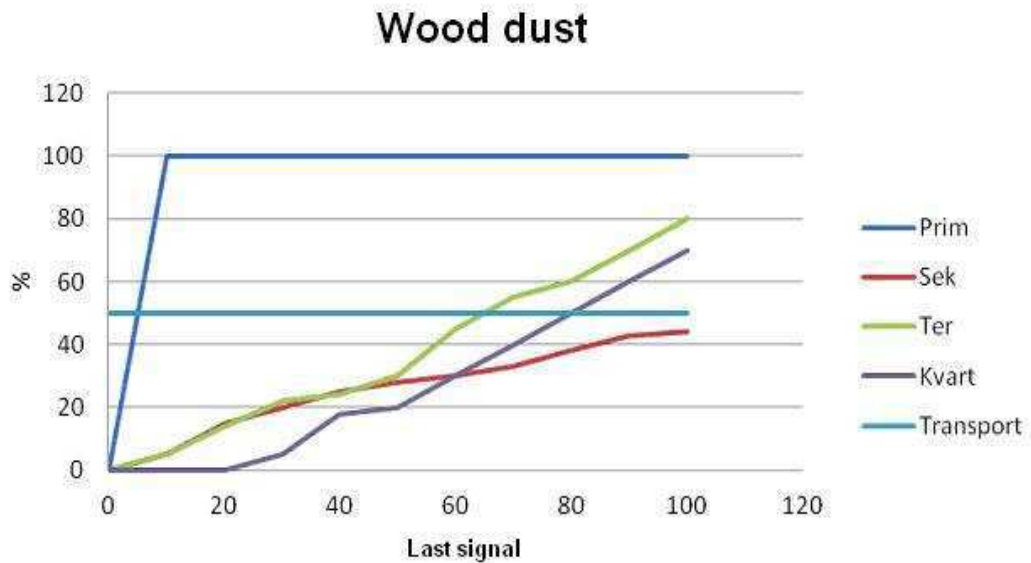

Figure 28. Load controls damper settings for wood dust operation

Manual

The load on the burner made manually on the controller. Minimum load is 0 % and maximum load is 100 % (Jacek Gromulski, 2012, page. 8)

Auto

The load on the burner is controlled by the regulator. Minimum load is 25 % and the maximum load is 100 %. (Jacek Gromulski, 2012, page. 8)

4.5.1 Wood dust control

Powder is fed to the system with dosing screws. The screws speed is controlled by frequency converters. The speed of the screws is controlled by the burner load. These screws can be stopped "Hard" from the security system. After dose screws the powder will go through a shaft to a rotary valve, the rotary valve is a type of cell-feeder which ensures a very even material flow. Rotary valve acts as a pressure lock between the transport line and the metering screws. The rotation of the cell feeder is monitored by a rotation sensor. Rotation detectors can give out alarms and stop the burner if necessary. (Jacek Gromulski, 2012, page. 4)

Air that leaks through the cell feeder is transported away by leak air fan and filters. The fan is positioned above the dose screws. The wood dust cleaning filter drops the gathered dust back into the shaft between the dose screws and the rotary valve. Wood dust is blown out of the rotary valve into a recorder using a blower. The blower, drive and transportation speed is kept constant at 22-23 m/s with the use of a speed transmitter. Speed transmitter is also used to alert and if needed to stop the burner if the speed drops below 18 m/s while wood dust is fired. Speed is also monitored by a pressure transmitter that can stop the burner "hard" if the speed of the line drops below 18 m/s. (Jacek Gromulski, 2012, page. 4)

A temperature transmitter measures the temperature of the incoming air. The pressure around the blower filter is monitored by a pressure switch. In transportation management, which is located after cell-feeder and recorder, there are two pressure transmitters measuring the pressure drops across the transport line going to burner. Connected to the burner there are two temperature switches that can hard stop the burner if the temperature inside the transportation line would rise above 100 °C. The transportation line is also equipped with a pneumatically operated valve, which closes when burner is stopped or fired with oil. This valve closes normally from the PLC but can be hard stopped by temperature guards. The only alarm that shuts the powder valve is when high temperatures are detected inside the wood dust line. In all other cases it's stopped by the stopping sequence. (Jacek Gromulski, 2012, page. 4)

4.5.2 Oil flow control

There are two ways to control the oil flow, manual and automatic. The manually controlled oil control valve is [70HC1442] (Jacek Gromulski, 2012, page. 5)

The auto-controlled oil is controlled by an oil flow regulator [622FC119]. A flow transmitter [622FC119] affects the oil control valve [622FC119-FV] by regulating the oil flow. The value to the controller is taken from the output of steam pressure regulators. Oil flow is approximately 0-2850 l/h. (Jacek Gromulski, 2012, page. 5)

4.5.3 Transportation speed for wood dust

The speed of transport management systems depends on the load. The speed of the blower [622PU] is controlled by the controller. Speed transmitter [622FC] affects the speed of the blower through the speed regulator. The speed of the transporter uses set points that follow the output of the burner regulator. If the speed decreases below 19 m/s an alarm will start and recorder will stop if wood dust is fired. This will delay the firing by 10 second. The recorder will stop hard by the safety circuit if the speed drops below 18 m/s. (Jacek Gromulski, 2012, page. 6)

4.5.4 Changing the fuel from oil to wood dust

The necessary steps to switch the fuel used from oil to wood dust.

Step 1

Wood dust Valve [622ES142] opens, when the limit switch [622ES142-EV-3] on the valve indicates that valve open sequence is starting.

Step 2

Leak air fan has started. Filter cleaning is activated, for leak air filter.

Blower [622PU] starts. When the speed of the transmitter [622FC] indicates a velocity of 20 m / s the sequence is advanced further

Step 3

Rotary valve [622CV] starts. When the rotation sensor indicates, the operating sequence goes on.

Step 4

Metering screws [M502] start on minimum output.

Step 5

The output of dose screws [M502] is increased by 1 %/ sec.

The output to the oil control valve [622FC119-FV] is reduced by 1 %/sec of the program.

Step 6

Wood dust firing will be taken off the load, when the output signal to the oil control valve [622FC119-FV] drops to 0, and when dosing screws reach the current load.

Signal [open oil] activated

Atomization valve [622PC112-PW] opens for cooling, the oil lance.

Oil Valves [622ES122 and 62ES121] closes.

Return oil valve [622ES125] opens.

Blow valve [622ES115] opens in 60 sec.

(Jacek Gromulski, 2012, page. 6)

4.5.5 Changing fuel from wood dust to oil

The necessary steps to switch the fuel used from wood dust to oil.

Step 1

Oil Control Valve [622FC119-FV] closes.

Atomization valve [622PC112-PW] opens the set point for oil.

When the pressure switch [622PC112] for atomizer valve indicates pressure is to commence further

Step 2

Signal [Open oil valve] is activated.

Oil Valves [622ES122 and 62ES121] opens

Return oil valve [622ES125] closes

Step 3

The output to the oil control valve [622FC119-FV] is increased by 1% / sec.

The output at doses screws [M502] is reduced by 1% / sec of the program.

Step 4

When the output signal to the dosing screws [M502] is 0 and the oil control valve [622FC119-FV] oil flow regulator takes [622FC119] over.

The burner is now regulated for oil

Metering screws [M502] stops 6 sec

Step 5

Rotary valve [622CV] stops.

Blower [622PU] stops.

Leakage air fan [see Dosage] stops, filter cleaning stuff [see dosage] 20 sec

Step 6

Wood dust Valve [622ES142] closes.

(Jacek Gromulski, 2012, page. 7)

4.5.6 Trimming Oxygen O₂

When co-firing the boiler and the burners, Oxygen O₂ is regulated by the bark boiler. Air dampers to the burner work as a rate control system that is associated with the dosing screws. While the burners are at peak load, the air is regulated to the burner, through the O₂ regulation. If the boiler is fired only with the burners, O₂ control is also used via existing O₂. (Jacek Gromulski, 2012, page. 8)

5 Safety related systems (SRS)

Safety related systems are a very important cautionary method for process industry to ensure the safety and functioning of the operations. Functional safety of the system means the part of the system that is very reliable of the correct and timely executed functions in the system. Functional safety is sufficient when the process and systems that are related to the process are set up properly and they work reliably and as expected, and they do not cause any damage or danger. A safety related system will have to be functionally and by structure correct for the specified use and conditions. (Lauri Mannermaa. 2008, page. 4)

Set requirements for a safety related system:

- SRS will have to be separate from usable automation and totally independent of it.
- Characteristics and dangers of the used process will have to be taken into account when designing the safety related system to ensure sufficient reliability.
- Safety, reliability and aptitude of the equipment used in the current system must be possible to locate and assessed.
- For safety use, the primarily equipment with the right type and certification should be used.
- The System should work without any flaws, even in dangerous situations should happen only once in the life cycle of the facility.
- System can not be the cause of any unnecessary stops or rundowns that can threaten the safety of the process.
- The equipment will have to be as maintenance-free as possible and easily maintained and testable.
- The process should include a manually operated stopping switch that is separate from the system.
- During disruption, actuators stay or will switch to pre-defined safe state.

(Lauri Mannermaa. 2008, page. 4)

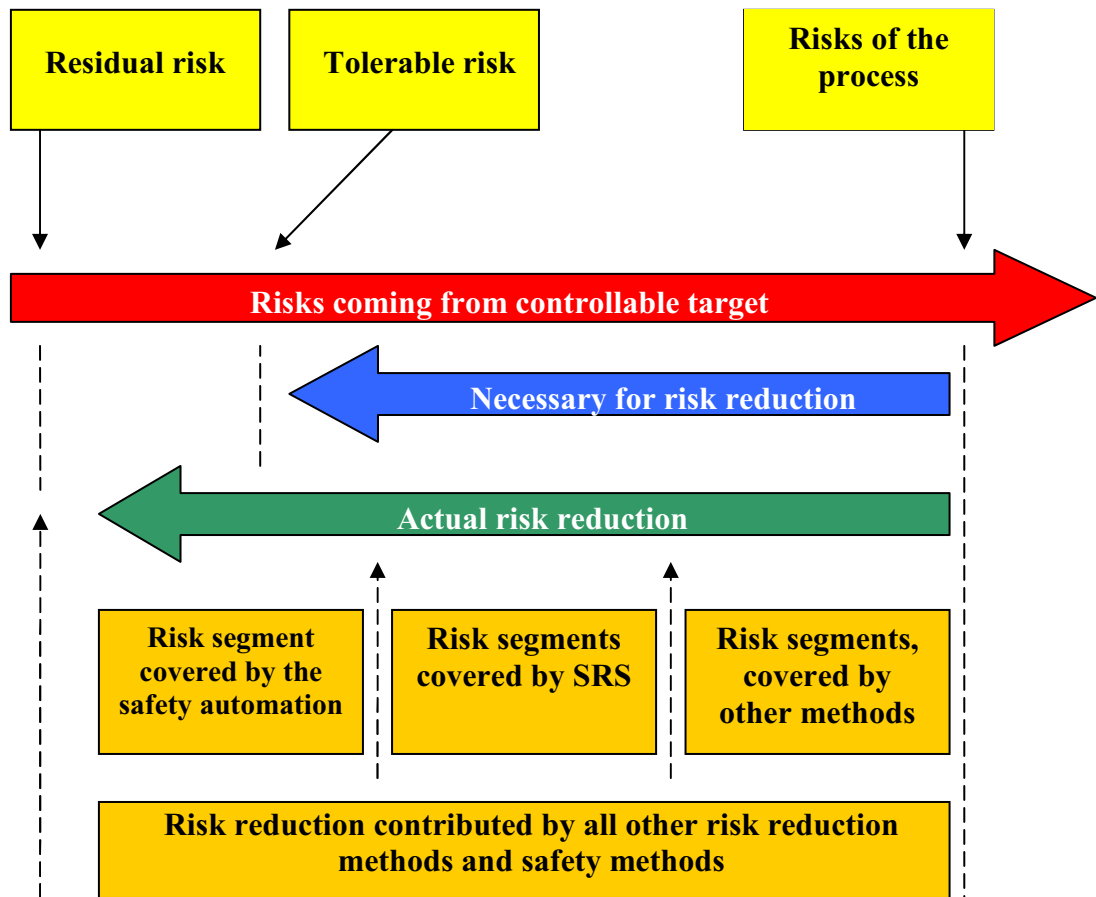

Figure 29: Risk reduction, general principles

Figure 29 presents general principles of risk reduction. Risks of the process mean a risk that can be caused by the process itself or from its interaction with control system, including activities performed by the operators. A tolerable risk is defined as a risk that is approved by the society's standards. These standards can vary depending on the industry, country or firm in question. Residual risk should be smaller than the tolerable risks. Risk reduction methods are used to achieve these goals. (Lauri Mannermaa. 2008, page. 5)

5.1 Design conditions

Construction and explosion risk design of the facility is based on "Provisional Classification and Risk Assessment SCA Östrand Rev. 4" that Brunicon AB carried out on the behalf of Andritz AB. (Göran Jansson. 2011, page. 1)

The contents of this explosion safety information have also been accepted by the SCA Graphic Sundsvall Östrand on completion of the project. Classification and risk assessment responsibility is under AFS 2003:3. In the above classification and risk assessment, the design values are based on of the potentially hazardous substances that are assumed to be have been handled in the plant. The values that apply from wood dust to pellets have been specified by the SCA. (Göran Jansson. 2011, page. 1)

5.1.1 Measuring acceptable explosion safety

This is a description of how the explosion safety of the facility for manufacturing wood dust at SCA Graphic Sundsvall AB Östrand has been taken care of the parts that Andritz is responsible for. This description is accompanied by the classification and risk assessment according to AFS 2003:3, which is based on CE authentication of the plant according to the Machinery Directive AFS 2008:03 Appendix 1 paragraph 1.5.7 (Göran Jansson. 2011, page. 1)

In similar facilities, there have been accidents and incidents due to fire, explosion, and in connection with maintenance work. (Göran Jansson. 2011, page. 1)

The outlined risk assessments above have led to a number of measures that had to be taken in the construction of the facility described below (Göran Jansson. 2011, page. 1)

5.1.2 Dust explosion

Explosion is a rapid increase in volume and release of energy. Explosion generates a high temperature and a release of gases. Explosion will also create a shock wave. Gases caused by explosion are capable of causing certain kinds of explosions:

Tank of compressed / liquefied gas gaps	(Pressurized Explosion)
Sudden boiling off solvent	(Steam explosion)
Sudden heating of air, For example by lightning, electricity	(Hot-air explosion)
Rapid chemical reaction, producing gas	(The gas explosion, explosion, explosion of explosives)
Fast chemical reaction that does not Produce gas but suddenly heats the air	(Dust explosion, explosion of explosives)

The upper examples account for the general type of explosions in a dust burning environment. Usually most of the explosions are steam, air and combustion based explosions. (Anders Knutsson. 2011, page. 6)

5.2 Safety and control systems for burners

For the powder plant, we propose a distributed control system (DCS) that controls the fuel receiving and fuel preparation etc. are controlled by a local controller at fuel preparation, while the burners and furnace are controlled by a system located at the boiler hall. The two systems communicate with each other and with the overall scheduling system of Östrand. The controller controls motors placed at substations, located at each plant section. (Jacek Gromulski, 2010, s6)

The boiler hall burner controlling station stands directly on the burner hall platform, while the central controller and the heavy motor drivers are placed separately in a dedicated area with adequate cooling and protection. All four burners are provided

with flame sensors each, and with dual detectors for UV (gas and oil-fired) and with an infrared detector for the heating of solid fuel. Burner control and regulations are managed by a new control system (like the ABB 800-system) supplemented with an independent safety system (thing) to produce hard threaded monitoring especially of the critical functions. (Jacek Gromulski, 2010, page. 6)

A burner monitoring system consists of:

- 1 x Control cabinet for safety monitoring
- 2 x Fireye main flame guard 95DSS2E-1CG (including the front piece)
- 2 x Hegwein automatic firing system AAUS620L20
- 1 x Control cabinet for the combined burners
- 2 x Fireye main flame guard 95DSS2E-1CG (including the front piece)
- 2 x Fireye fuel dispenser series M2 including detector UV1A-3

6 From technical innovation to productized offerings

Innovative technology and products are a good base for successful business but something more is always needed. Customers are usually not ready to buy the latest product if there is no extra gain or value to them to do so. A firm must have a broadened view to its products to respond to this. (Simula, H., Lehtimäki, T. Salo, J. 2008, page. 1)

A firm should put effort into creating a comprehensive, extended product on top of the core product. This is called productization. In essence productization requires inbound activities that secure the quality of the core product but also lead toward the formation of an extended product. (Simula, H., Lehtimäki, T. Salo, J. 2008, page. 1)

Productization makes it easier to the buyer to understand what is being offered and helps the firm offering the product to come up with a well-defined product without sacrificing innovativeness. (Simula, H., Lehtimäki, T. Salo, J. 2008, page. 1)

6.1 Productization

Productization “refers to the process of analyzing the needs of customers in the target market, designing the product and developing the ability to produce it.” (Simula, H., Lehtimäki, T. Salo, J. 2008. s 3)

The goal of productization is to make a sellable package of the offering, technology or service, so the customer can understand the contents of the offer in advance. Productization consists of producing, defining, improving, describing and continuously developing the offering so that the benefits of the customer are maximized and the organizations goal achieved. The process where an ultimate product is formed is called productization. The figure 30 demonstrates the productization level in the context of service and technology. (Simula, 2008, page. 5)

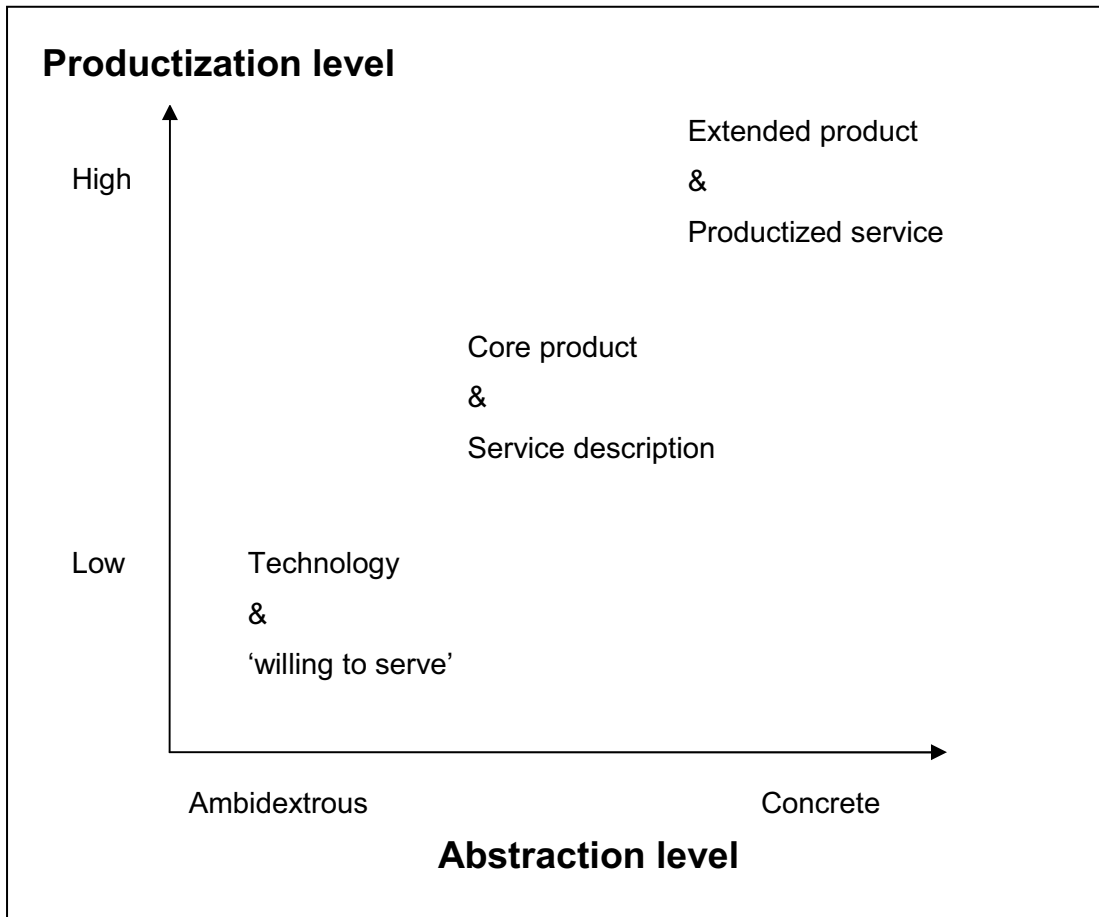

Figure 30. Productization level in the context of service and technology illustrated (Simula, 2008, page. 5)

6.1.1 Inbound productization

The main purpose of inbound productization is to harmonize and systemize the offering delivery process and its outcome inside an organization. (Simula, 2008, page. 6)

For example, normal engineering work from scratch creates extra costs. Various product management methods and tools have been used to help with problems and conflicts and to get the product to the market faster. A sophisticated utilization of these methods can be seen as an essential part of productization efforts. Use of rationalization or formalization does not mean that all work should be standardized. The requirements of inbound productization differ between projects and firm find a good balance between standardization and customization. (Simula, 2008, page. 6)

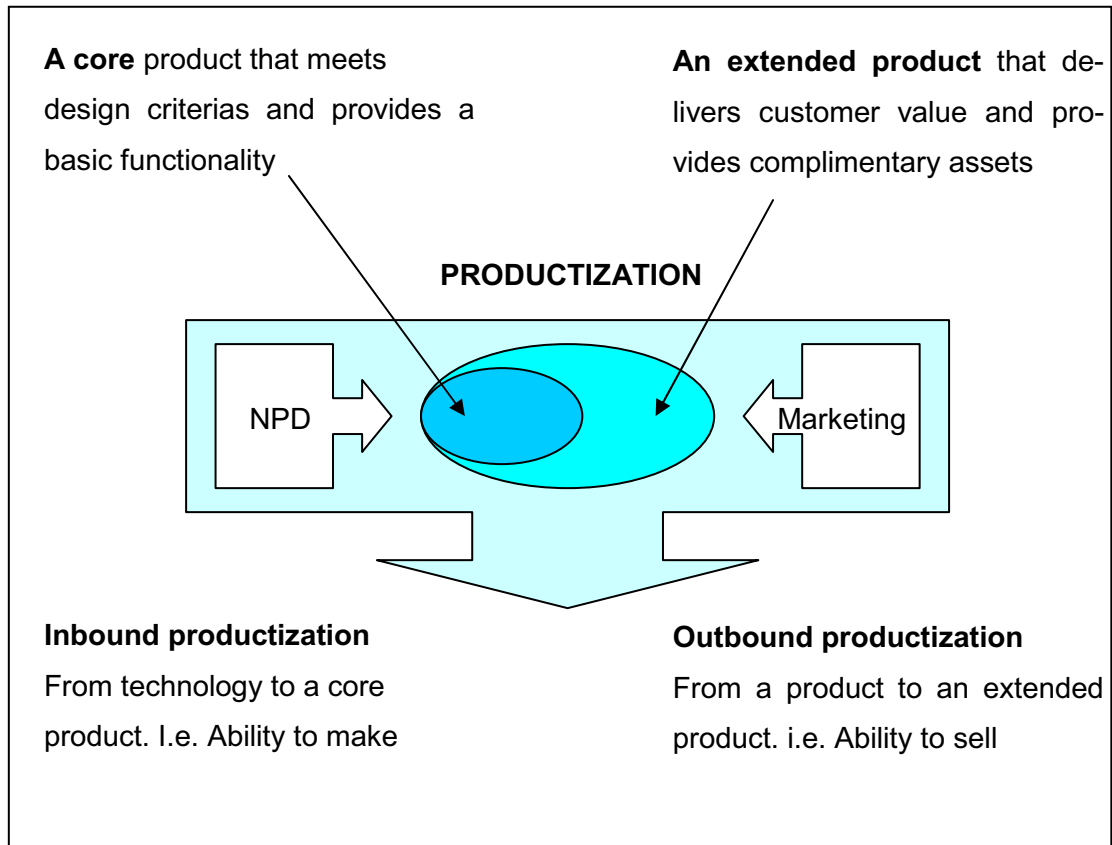

Figure 31. Conceptual illustration of productization (Simula, 2008, page. 7)

Backbone of the firm is a good core product. In order to have a core product, a firm has to create a path from technology to a core product. See figure 31 above for conceptual illustration of productization (Simula, 2008, page. 6)

Inbound productization means in practise, various engineering related tasks such as:

- Final design specifications
- Material selection and sourcing
- Production tools (moulds, jigs,)
- Assembly instructions
- Manufacturing ramp-up
- Product data management
- Testing the process and quality control
- Certifications and accreditations

The main goal of productization is come to up with a variety of products, which vary in shape and size. In conclusion inbound productization is an ability to make. (Simula, 2008, page. 7)

6.1.2 Outbound productization

The main goal of outbound productization is to make the product more visible and concrete for the customer. It also increases value of the product as seen by the customer. Things like brand, design, training and after sales services are a few of the things that can add value on top of the product. (Simula, 2008, page. 7)

Success of overall productization is dependent on the firms understanding of the market's needs. (Simula, 2008, page. 7)

The outcome of successful outbound productization is called an extended product. Achieving this can be done with the help of various marketing related tasks:

- Branding and naming
 - Warranties and technical support
 - User guides and documentation
 - Advertisements, brochures and white papers
 - Customer testimonials
 - Contracts and/or licence terms
 - Sales channels and commissions
 - Sales tools and price lists
 - Logistics and packaging
- (Simula, 2008, page. 7)

Outbound productization is the other part of the productization process. After completion, a firm has reached a point when the product is ready to be sold to customers. The core product is the realization of this potential but an extended product is required to communicate the real performance, value and worthiness of that product. (Simula, 2008, page. 7)

7 Summary

Main goal for this was to gather and translate all the documents and information concerning the new co-fired wood dust / oil burner system implemented at SCA Östrand mill. Andritz also wanted to evaluate the possibility to productize these types of burners and maybe add them into their product list. For productization purposes it was necessary to gather information of every aspect concerning the new burner operations, pellet manufacturing, storing and transportation, oil and wood dust burning, emission and emission control and safety related systems. Andritz is so far pleased with the results, which was to gather all the necessary information needed to productize and to continue the development of these types of burners.

Project itself was unique, interesting and first of its kind for Andritz. What makes this project even more special was that the project was handled together by many different Andritz divisions from two different countries. This was all handled and executed well and the results were really well working burner environment. The new co-fired burner system was part of a much bigger modernization project for the lime kiln. The costs of these new burners are fairly small when compared to the costs of the modernization work for the lime kiln. All the benefits achieved with the new burners make this product truly desirable option.

From project management perspective, there are no regrets when looking back on how the project was managed from Andritz side and the project would be handled the same way if done again. Some time and money could have been saved for both Andritz and SCA if there would have been more information of how to handle safety aspects, like ATEX, human safety regulations, dust handling and explosion risks at the start of the project. In general there is often a short time to prepare for a project, during the sales phase. If done correctly a lot of money could be saved in the coming investments. Preparing for a project can be seen as costly procedure especially from the customer side.

Main fuel for the new burner system is wood dust (pulverized wood) the dust burned at SCA Östrand is gotten from Bio Norr as pellets, which is then crushed into fine wood dust. The use of wood dust as the main fuel in the new burner system is estimated to pay itself back in just few years. But since the pellets are gotten from another SCA (Bio Norr) mill the final costs for pellets / transportation / wood dust can be much lower than normally.

Taxation of light fuels in Sweden is more than three times the level in Finland. Because of this Sweden has made a lot of progress towards much greener energy consumption. About 70 % of Finland's pellet production is exported to other countries, mainly Sweden. Bio fuels in Sweden are more common not just in mills and plants but in common households. Finland is also planning to increase the taxation of fuel oils but it'll still be lower than that in Sweden. (HS.fi, 2012)

Emissions of, from burning wood dust in LOW NO_x burners are estimated to be much lower than burning fossil fuels. Not just in Finland and Sweden but in whole EU-area, work towards more greener and emission free environment, has been one of the main concerns of the last 10 years. The exchange of fuels used in plants, mills and factories to bio fuels is not easy and will take time, governments will have to take more active role and adjust taxations of fuels to encourage the switch to much greener energy.

There will be two versions of this thesis one for school and one for Andritz. In this version the part where these types of wood dust burners are productized is left out, since this information is confidential. Material to be added in the Andritz version of the thesis:

- Burners, dimensioning and burner design –information (In more detail)
- Possibly making a CFD model out of the burners
- Burner emissions and burner guarantee test results
- Safety related systems included in the baggage, with the burners
- Burner automation coupling surface, into plants existing DCS and development of the related modules
- Defining the limits of the deliveries coming from Varkaus boiler division

8 REFERENCES

Andritz.com, 2.4.2012, 10:06, about us, <http://www.andritz.com/index/group/gr-about-us.htm>, internet

Andritz Feed & Biofuel A/S, Cyclone Filter manual, EFF SM-R-2.S.pdf, denmark, Andritz materia

Asikainen Ari, Jalovaara Jukka, 2002, Poltto ja palaminen, International Flame Research Foundation – Suomen kansallinen osasto, Jyväskylä, published

Bloomengineering.com, 4.4.2012, 12:40, Low NOx Burners, <http://www.bloomeng.com/low-NOx-Burners.html>, internet

Champion, 1996, Hammerkvarn serie, Andvänder- och reservdelshandbok, 441279+441281+441283 Manual+Parts.pdf, USA, Andritz material

CPM Europe, 19.3.2012 10:05, Hammer Mill Champion series, <http://www.cpmeurope.nl/index.php?id=48>, Internet

Feedmachinery.com, 19.3.2012 12:50, Hammer Mills: hammer Mills http://www.feedmachinery.com/glossary/hammer_Mill.php, Internet

Fireye.com, 26.8.2008, Flamvakt.CU-95, Integrated flame scanner with internal flame relay, Andritz material

Gromulski Jacek, 28.1.2010, Andritz, Industriell förbränning kb, Burner design, Andritz material

Gromulski Jacek, 19.1.2012, Andritz, Industriell förbränning kb, Regulation and control Multifuel burner oil / wood dust, Andritz Material

HS.fi, 21.5.2012, Finland falls behind many other contries on climate issues <http://www.hs.fi/english/article/Finland+falls+behind+many+other+countries+on+climate+issues/1135230729061>

Jansson Göran, 15.3.2011, Andritz, Explosionssäkerhet, CE-verifiering SCA Bioloop 2011, Sweden, Andritz material

Karvonen Aki 16.09.2011. Huolto- ja kunnossapitoliiketoiminnan tuotteistaminen. Varkaus, thesis

Knutsson Anders, Mars 2011, Rapport 2011:2, Andritz, Faror och hälsorisker vid förvaring och transport av träpellets, träflis och timmer i slutna utrymmen, Sweden, Andritz material

Lachenmeier-monsun.com, 29.2.2012 10:12, Bucket Elevator, <http://www.lachenmeier-monsun.com>, Internet

Mannermaa Lauri, 1:2008, Turva-Automaatio Prosessiteollisuudessa, Tukes, Turvatekniikan keskus, Helsinki, 2008, Internet

Promaint, 2.2008, Typpioksidipäästöt alas voimakattiloissa, <http://www.promaint.net/downloader.asp?id=2955&type=1>, Internet

SCA.com, 14.2.2012.09:40 SCA Östrand general information, <http://www.sca.com/en/sundsvall/sca-sundsvall/ostrand-pulp-Mill/>, Internet

Simula, H., Lehtimäki, T. Salo, J. (2008). Re-thinking the product – from innovative technology to productized offering. Proceedings of the 2008 International Society for Professional Innovation Management conference, 15-18 June, Tours, France. http://oulu.academia.edu/JariSalo/Papers/1247319/Re-thinking_the_product_from_innovative_technology_to_productized_offering, internet

Tomal Metering Systems, 2007, DRIFT- OCH SKÖTSELINSTRUKTION FÖR DOSERARE D&S_, doserare.pdf, Andritz material

Vos John, 2005, Biomass Energy for Heating and Hot, Water Supply in Belarus, Part A Biomass Combustion, Netherlands 2005 <http://www.aure.si/knjiznica/GEF/practa.pdf>, Internet

Welling Harald H, Thom J. Shaw, Energy From Wood Biomass Combustion

In Rural Alberta Applications, Canada Edmonton AB,
[http://www1.agric.gov.ab.ca/\\$department/deptdocs.nsf/all/apa11648/\\$file/alberta_wood_biomass_report.pdf?OpenElement](http://www1.agric.gov.ab.ca/$department/deptdocs.nsf/all/apa11648/$file/alberta_wood_biomass_report.pdf?OpenElement), Internet

