



**COMPARISON OF ULTRAFILTRATION
AND SIZE-EXCLUSION
CHROMATOGRAPHY PERFORMANCES
FOR PROTEINS DESALINATION**

Arina Akhmetova

Bachelor's thesis
November 2014
Degree Programme in Paper,
Textile and Chemical Engineering

TAMPEREEN AMMATTIKORKEAKOULU
Tampere University of Applied Sciences

ABSTRACT

Tampereen ammattikorkeakoulu
Tampere University of Applied Sciences
Paper, Textile and Chemical Engineering

Arina Akhmetova:

Comparison of ultrafiltration and size-exclusion chromatography performances for proteins desalination

Bachelor's thesis 41 pages

November 2014

Protein purification is a part of biotechnology. Its application can vary from laboratory researches to industrial production. Nowadays there are a lot of different methods of purification, which involve chromatographic and membrane-based separations.

This thesis work was based on research project which was done during my practical training in summer 2013 in IUT Nancy-Brabois.

The objectives of this work were to define the best conditions of size exclusion chromatography and ultrafiltration for separation protein-salt mixture, to observe its effect on performances such as purity, production yield, productivity, and to compare these two methods. It is important for process optimization, saving time and energy.

This work consists of two parts: theory background and experimental. In first part different purification methods, basic principle of chromatography and membrane based separations are explained for better understanding of the research project. The information is based on literature review. In second part process of work is described and obtained results are shown.

The performances of these separation methods depend on different conditions: in ultrafiltration it is flow rate and diavolumes, in chromatography it is injection volume, bed height and flow rate. The results show that in laboratory scale ultrafiltration is more efficient in protein desalination, but with this method high values of purity cannot be reached without losing sufficient protein mass.

Key words: chromatography, high performance liquid chromatography, membrane based separation, ultrafiltration.

CONTENTS

1	INTRODUCTION	6
2	PROTEIN PURIFICATION	7
2.1	Affinity chromatography	7
2.2	Immobilized metal ion affinity chromatography	7
2.3	Size exclusion chromatography	8
2.4	Ion exchange chromatography	8
2.5	Hydrophobic interaction chromatography	8
2.6	Chromatofocusing	9
2.7	Reversed phase chromatography	9
2.8	Ultrafiltration	9
3	CHROMATOGRAPHY	10
3.1	Chromatography classification	10
3.2	High-performance liquid chromatography	11
3.2.1	Chromatography mechanisms	12
3.2.2	Media selection in SEC	13
3.2.3	HPLC system	14
3.2.4	Detectors	15
4	MEMBRANE BASED BIOSEPARATION	17
4.1	Filtration system	17
4.2	Classification of membranes	18
4.2.1	Classification according to membrane structure	18
4.2.2	Classification according size of pores	19
4.3	Membrane selection	20
4.4	Diafiltration	22
5	EXPERIMENTAL PART	24
5.1	Measurement of concentration	24
5.1.1	Calibration	24
5.1.2	Effect of salt and protein concentrations	25
5.2	Chromatography	27
5.3	Filtration	27
5.3.1	Ultrafiltration	27
5.3.2	Diafiltration	28
6	RESULTS	29
6.1	Chromatography	29
6.1.1	Experimental results	29

6.1.2 Simulation results.....	30
6.1.3 Performances.....	31
6.2 Diafiltration.....	33
6.2.1 Experimental results.....	33
6.2.2 Calculation	34
6.2.3 Performances.....	35
7 DISCUSSION	37
REFERENCES.....	39

ABBREVIATIONS

AC	affinity chromatography
CF	chromatofocusing
DF	diafiltration
DV	diavolume
HIC	hydrophobic interaction chromatography
HPLC	high-performance liquid chromatography
IEX	ion exchange chromatography
IMAC	immobilized metal ion affinity chromatography
RPC	reversed phase chromatography
SEC	size exclusion chromatography
TLC	thin-layer chromatography
UF	ultrafiltration

1 INTRODUCTION

Protein purification is an important part of biotechnology. Many studies have been conducted to choose the most optimal purification strategy and to optimize properties of proteins for specific industrial applications.

The degree of purity of protein depends on its end use: for some applications it is enough to have crude extract, but for food or pharmaceutical uses level of purity should be very high (Iritani, Katagiri & Mukai 2003; Phillips 2014).

There are many purification methods which are used industry. The purpose of this thesis work is to get familiar with different purification methods, to define the effect of different conditions on performances and to compare size exclusion and ultrafiltration methods in terms of productivity. The theory background was obtained from literature. Studying of chromatography and ultrafiltration processes and its performances was done experimentally and comparison of these two methods was done based on results of the experiment.

2 PROTEIN PURIFICATION

Protein purification is performed in scales from micrograms for laboratory researches to tones for industrial purposes. Nowadays most of proteins can be easily separated using modern separation methods. Most of them involve chromatography, which is based on differences between properties of protein to be purified and properties of other compounds in mixture. Also, membrane-based separations can be used. (GE Healthcare 2010b, 15–17)

2.1 Affinity chromatography

Affinity chromatography (AC) is based on an interaction between the protein and a specific ligand attached to a chromatography matrix. The interaction can be biospecific, for example, antibodies are binding protein, or non-biospecific, for example, protein is binding a dye substance. The binding is happening under favorable conditions. During the run material, which is not bond, is eluted first. Elution of bounded protein is done by changing conditions, for example, pH, polarity. Because of high selectivity AC can be used as single-step purification. (GE Healthcare 2010b, 17)

2.2 Immobilized metal ion affinity chromatography

Immobilized metal ion affinity chromatography (IMAC) is based on the interaction between proteins with histidine residues on its surface with divalent metal ions immobilized via chelating ligand. Histidine-tagged proteins have very high affinity in IMAC because of the multiple histidine residues and usually they are strongest binders among all proteins in a crude extract. Elution of protein is performed by using gradient of imidazole. Histidine tag is amino acid motif in proteins which consists of histidine residues linked to the N- or C-terminus of the protein. The histidine tag is a strong metal ion binding. (GE Healthcare 2010b, 20)

2.3 Size exclusion chromatography

Size exclusion chromatography (SEC) separation is based on differences in molecular size. It can be used in protein purification or group separation (for example, protein desalting). SEC is non-binding method, sample is not concentrated. During the run protein is diluted, that is why loaded sample volume must be kept quite small, because it can effect on resolution. But capacity can be increased if sample will be concentrated before run, but not too much – on concentration levels higher than 70 mg/ml viscosity can effect on resolution. SEC is mostly done on final purification step, remaining impurities are removed. Usually, it is not used as first purification step, but can be used for small samples. SEC can be used for protein DNA purification, buffer exchange, desalting. (GE Healthcare 2010b, 21; Harvard Apparatus, 2)

2.4 Ion exchange chromatography

Ion exchange chromatography (IEX) separation is based on the reversible interaction between charged protein and oppositely charged medium. Elution of protein is performed by increasing of salt concentration or changing pH. Target protein is concentrated during the binding and collected in purified, concentrated form. IEX is used not only for binding of target protein, but also for binding impurities. IEX can be used in any part of purification procedure: in the beginning to extract target protein and some bulk impurities from large-volume sample, as an intermediate step, in the end to remove all remaining impurities. (GE Healthcare 2010b, 23)

2.5 Hydrophobic interaction chromatography

Hydrophobic interaction chromatography (HIC) is based on differences in hydrophobicity. During the separation hydrophobic protein reversibly interacts with hydrophobic surface of medium, while less hydrophobic protein is eluted. Target protein elution is performed by decreasing the salt concentration. HIC can be used on any purification step. HIC is especially very good after ammonium sulfate precipitation. (GE Healthcare 2010b, 25)

2.6 Chromatofocusing

Chromatofocusing (CF) is based on differences in proteins isoelectric point (pI). Isoelectric point is pH at which molecule does not migrate in electric field. As a medium weak anion exchanger is used. A pH gradient is generated as buffer, during the run it goes down. Proteins with different isoelectric point values go down the column at different rates. Protein with highest pI elutes first. Mostly, CF is used in analytical separations, and used in preparative purification only if desired purity cannot be achieved with other purification methods. (GE Healthcare 2010b, 27)

2.7 Reversed phase chromatography

Reversed phase chromatography (RPC) separates proteins and peptides basing on its hydrophobicity. This method is widely used for purity analyses and not recommended for preparative protein purification since a lot of proteins are denatured (denaturation is a process of modifying the molecular structure of protein (Encyclopedia Britannica)) by organic solvents. (GE Healthcare 2010b, 28)

2.8 Ultrafiltration

Ultrafiltration (UF) is usually used in protein concentration, desalination and purification. It is membrane-based separation method based on differences in molecule size. During the run impurities are rejected by membrane and protein goes to retentate solution. Impurities are washed away, the volume of retentate is decreasing, and protein concentration is increasing. For purification diafiltration should be used: during the run retentate solution volume retains the same, protein concentration retains the same (with some loss), impurity concentration (e.g. salt) is decreasing. Because of losses it cannot be used for obtaining high purities of high sample volumes. (Janson 2011, 11; Millipore 2003, 1)

3 CHROMATOGRAPHY

Chromatographic processes generally involve distribution of mixture between two phases (stationary and mobile). The mixture is dissolved in mobile phase and moves through stationary phase. Different compounds have different degree of interaction with phases, so they are travelling with different rates. The separations are based on adsorption, partition and ion exchange, depending on type of stationary phase. (Ghosh 2006, 150–151)

3.1 Chromatography classification

Chromatographic methods are divided on 2 big groups: column chromatography and planar chromatography (Scott 1995, 10).

In column chromatography, the stationary phase is held in column and the mobile phase is forced through the column by pressure or by gravity. It includes among other methods high-performance liquid chromatography (HPLC) and gas chromatography. (World Health Organization 2014)

Gas chromatography is a form of column chromatography method which is used for separating and analyzing compounds which can be vaporized without decomposing. The mobile phase is a carrier gas which is usually inert. As a stationary phase active adsorbent such as alumina, silica gel or inert solid support such as firebrick, glass beads covered with thin liquid layer can be used. The mixture to be analyzed is introduced in vaporized state into the carrier gas stream and then it goes down the column. Compounds of mixture are separated because of different degree of interaction with stationary phase. (Barry & Grob 2004, 27)

HPLC method is based on adsorption, partition and ion exchange, depending on the type of stationary phase. Gel packed into the chromatography column is used as stationary phase, and liquid solvent is a mobile phase. Separation of compounds is based on its degree of interaction between these two phases. (Ghosh 2006, 151)

In planar chromatography stationary phase is supported on plate or paper. The mobile phase moves by capillary action or gravity. It includes thin-layer chromatography (TLC) and paper chromatography. (World Health Organization 2014)

TLC is chromatographic method which is performed on glass plate or aluminum or plastic foil covered by thin layer of a powdered adsorbent material (silica gel, cellulose, etc.). This layer is stationary phase. The mixture to be analyzed is spotted near the bottom edge of plate and placed into pool with solvent. The mobile phase (solvent) is moving across the surface of the plate by capillary action. Separation of compounds is happening because of its adsorption or partition and based on different rates. This method is widely used in pharmaceutical industry to achieve the lowest levels of impurities in medical substances. (Fried & Sherma 1999, 1–2)

Paper chromatography method is similar with TLC, but in this method sheet of paper of right texture and thickness is used as stationary phase. Nowadays this method was mostly replaced by TLC because chromatographic separation on paper goes slower than on thin-layer plates, and separations using TLC are clearer. (World Health Organization 2014)

3.2 High-performance liquid chromatography

Liquid chromatography is a separation method based on the dynamic distribution of molecules which should be separated between two phases: stationary and mobile. It happens in chromatography column, where packed bed is stationary phase. The mobile phase is passing through the column with fixed speed. Usually it is a liquid, which does not react with solution and does not interact with stationary phase. Solution is injected to the column with mobile phase. Velocities with which molecules are passing through the column depend on its interaction with stationary phase: more molecules interact with it – lower its speed. (Mori & Barth 1999, 11)

Liquid chromatography is used for separation of proteins, lipids, hormones, nucleic acids, etc. Also it can be used for analytical purposes to recognize a composition of mixtures.

3.2.1 Chromatography mechanisms

According to Ghosh (2006) liquid chromatography can be based on different mechanisms: ion exchange, reverse phase, hydrophobic interaction, affinity, size-exclusion.

Ion exchange chromatography can be cation exchange - where molecules with positive charge are interacting with negatively charged stationary phase, and anion exchange – where negatively charged molecules are attracted to positively charged stationary phase. As a mobile phase low or medium conductivity salt solution is used. So, the adsorption of the molecules depends on interaction between charged ionic groups in the sample molecule and in stationary phase. The molecules with weakest ion interaction start to elute from the column first, and molecules with higher ionic interactions require more time to leave the column. (Ghosh 2006, 153)

Reverse phase chromatography is based on adsorption of hydrophobic molecules on hydrophobic solid support in a polar mobile phase. The more hydrophobic molecules require more time to be eluted from the column. (Ghosh 2006, 153)

Hydrophobic interaction chromatography is based on hydrophobicity of the compound, which interacts with hydrophobic surface of a media. Different compounds have different degree of surface hydrophobicity. The interaction of them with stationary phase affected by presence of e.g. salts in mobile phase: higher salt concentration – more interaction. The most hydrophobic compounds elutes last, because they require a greater reduction in salt concentration. (GE Healthcare 2006, 9; Ghosh 2006, 153)

Affinity chromatography is based on the specific adsorption of the molecule to a ligand or macromolecule. In this case other mixture compounds which are not adsorbing are eluted from the column. This chromatography method is used when high purification yields are required. (Ghosh 2006, 153)

Size exclusion chromatography, or gel chromatography, is a method in which mixture of compound are separated according their molecular weight. As a stationary phase porous packing is used. Low weight molecules can go through the pores of stationary phase, so, they have long way to be eluted from the column. Larger molecules do not

interact with packing, so, they go with mobile phase velocity and are eluted first. (GE Healthcare 2010a, 9; Ghosh 2006, 154)

3.2.2 Media selection in SEC

For separation by SEC column is packed with size exclusion media. The media are inert porous spheres. The media is selected according SEC application (table 1). (GE Healthcare 2010a, 16)

TABLE 1. Media selection (Harvard Apparatus, 8)

Media Selection			
Type	Diameter (μm)	Cut-off (Da)	Application
G-10	40-120	≤ 700	Desalting peptides
G-25	40-120	≤ 1500	Desalting proteins and nucleic acids
G-50	50-150	100-5000	Removal of free labels from labeled macromolecules
G-100	40-150	1000-10000	Molecular weight determination
P-2	45-90	100-1800	Rapid carbohydrate and small peptide separation and desalting
P-6	45-90	1000-6000	Purification of proteins and polypeptides
P-30	45-90	2500-40000	Purification of proteins

When media is selected next characteristics should be considered:

- pore size
- pore volume
- particle size
- matrix rigidity

The pore size is chosen so, that large weight molecules are excluded from the gel matrix. But pore size should not be too small, so low weight impurities will not elute with desired product. (Amersham Biosciences 1998, 2)

The pore volume influences the sample volume, which can be used. In preparative chromatography matrix volume of desalting gel filtration medium should be as low as possible. However it cannot be too low, because matrix rigidity depends on its volume. Usually small pore volume can be compensated by using larger bed volume, what can badly effect on productivity. (Amersham Biosciences 1998, 2)

The particle size influence sample dispersion in the bed, but because large molecules do not enter the pores, it does not cause much problems with it. However particle size has big influence on pressure drop over the packed bed. (Amersham Biosciences 1998, 2)

High matrix rigidity allows using high flow rates for faster desalting (Amersham Biosciences 1998, 3).

Sephadex G-25 is one of the most common medias in protein desalting. Sephadex is a bed-formed gel prepared by cross-linking dextran with epichlorohydrin. Sephadex G-25 is one of the more rigid and has working pH range of 2-13. Due to rigidity of the matrix it can be used at relatively high flow rates for rapid separations. Sephadex is supplied as a dry powder, so before packing the column it should be swollen in buffer. Laboratory columns are packed by pouring swollen G-25 into the column and letting it settle to create an evenly packed bed. (Amersham Biosciences 1998, 2)

3.2.3 HPLC system

Typical liquid chromatography system (figure 1) consists of column, mobile phase reservoir, sample injector, detectors, pumps and collector. Mobile phase is pumped to the system and goes through the column. Sample is injected into the column. Next sample mixture is going with mobile phase. Different compounds are interacting with stationary phase, so velocities are changing according to the degree of these interactions – molecules with less interaction are eluted from the column first. Usually after the column absorbance, conductivity and pH are measured and recorded. Desired product can be collected. (Ghosh 2006, 152)

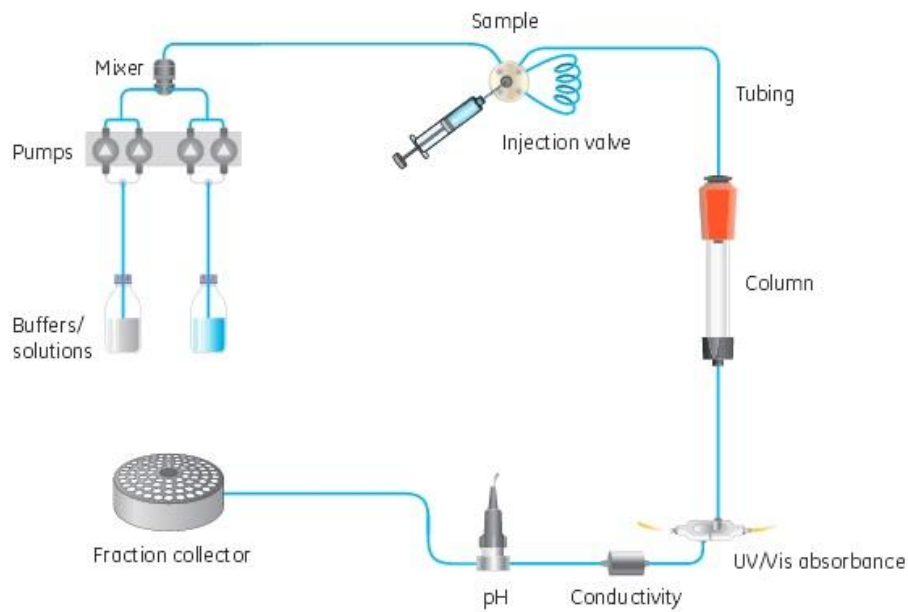

FIGURE 1. Chromatography system (GE Healthcare Handbook 2012, 7)

3.2.4 Detectors

Usually in chromatography inline detectors are used. For monitoring the protein purification process UV/Vis absorbance detector, because the most of proteins absorb light at wavelength 280. Also conductivity and pH monitors are used for monitoring of separation process (e.g. salt concentration is measured by conductivity meter).

Measuring absorbance at 280 provides information about protein which was eluted and about total amount of protein. Some chromatography systems have multi-wavelength detectors. It can detect possible impurities. Different biomolecules can absorb light of different wavelength (table 2) (GE Healthcare 2012, 41).

TABLE 2. Wavelength to detect different biomolecules (GE Healthcare, 41)

Wavelength (nm)	Absorption
214	peptide bonds, part of peptides and proteins
230	organic compounds or chaotropic salts
260	DNA/RNA
280	aromatic amino acids residues
390/420	coenzymes
490	green fluorescent protein
600	protein aggregates

The conductivity monitor is used to detect changes in salt concentration or other charged molecules during a run. A current is applied across a conductivity cell and the electrical resistance is measured between them and used to calculate conductivity. (GE Healthcare 2012, 44)

4 MEMBRANE BASED BIOSEPARATION

A membrane is a thin semi-permeable barrier which is used for bioseparations. Applications can be: product concentration, product sterilization, solute fractionation, solute removal from solutions (e.g. desalination), purification. The transport of material through the membrane can be driven by convection or by diffusion. Convection based transport is happening because of transmembrane pressure (figure 2). Diffusion based transport based on concentration difference. The principle of membrane based filtration is that membrane rejects high molecular weight solids, which are staying in retentate solution, and passes low weight and water, which go to permeate. So, because retentate volume is decreasing – concentration of high weight solids is increasing, and concentration of low weight compound remains constant. (Ghosh 2006, 200)

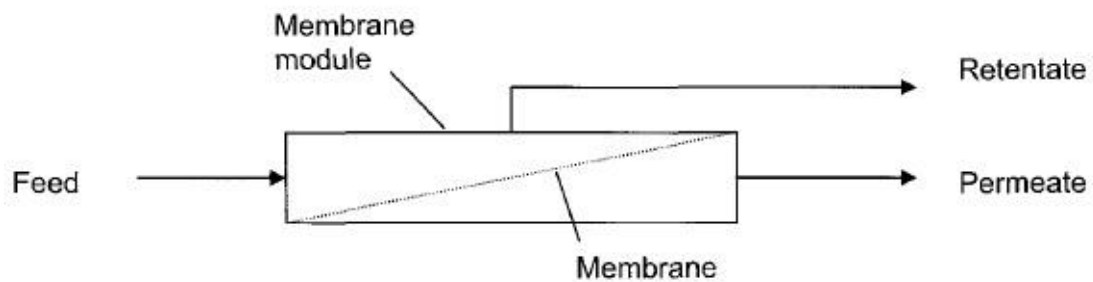

FIGURE 2. Pressure driven separation (Ghosh 2006, 200)

4.1 Filtration system

Basic filtration system consists of tank, membrane and pump. For ultrafiltrations tangential flow filtration system can be used (figure 3) (Millipore 2008, 13). It consists of:

1. Emergency stop button
2. Filter holder which holds membrane (cassette)
3. Flow cell with pressure sensor, which transmits retentate pressure
4. Flow cell with temperature/pressure sensor, which transmits feed temperature and pressure
5. Feed pump
6. Manifold – flow cell connecting tank tubing to the pump tubing
7. Tank – retentate vessel, which also has stir bar, which is spun magnetically

8. Touch Screen – user interface to run processes, configure system settings and display information about pressure, flow rate

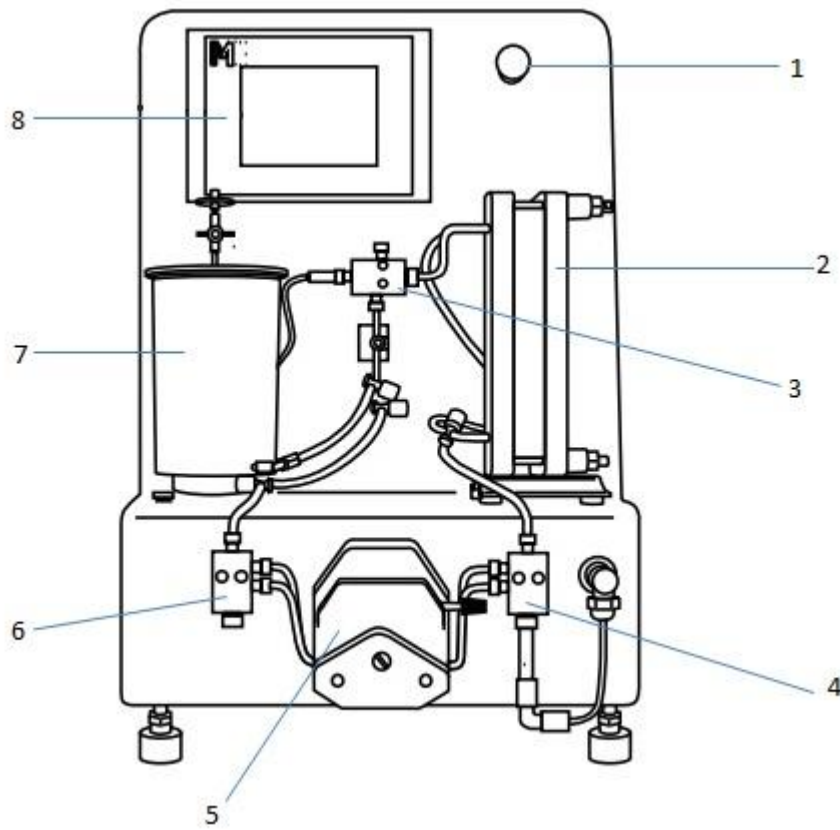

FIGURE 3. Cogent μ Scale TFF System (Millipore 2008, 9)

4.2 Classification of membranes

According to Degrémont (2007), classification of membranes can be based on:

- Membrane structure;
- Size of pores.

4.2.1 Classification according to membrane structure

According to structure membranes can be divided into three groups: homogeneous, asymmetrical and composite.

Homogeneous membranes have homogeneous structure along all its thickness. These membranes are pierced with quazy-cylindrical holes. (Degrémont 2007, 235)

Asymmetrical membranes consist of two layers: thin selectively permeable layer and thick layer with bigger pores, which provides mechanical strength properties and does not influence on water flow. Often it also has fabric support for reinforcing of thick layer. (Degrémont 2007, 235)

In composite membranes permselective layer is placed on porous support, which can be often asymmetrical. Since these two layers are of different types, selective properties of one layer and mechanical properties of another can be used in full extent. (Degrémont 2007, 236)

4.2.2 Classification according size of pores

Pressure driven membrane based processes can be divided according to the size of permeable species (figure 4).

Reverse osmosis (RO) membranes allow water to go through them and retain all dissolved particles which were in solution. In this process high transmembrane pressure is used in order to let water go from high solute concentration side to lower concentration side. Reverse osmosis is commonly used for water purification (Degrémont 2007, 238; Ghosh 2006, 206).

Nanofiltration membranes are retaining molecules such as peptides, hormones and sugars. Nanofiltration is used in food and dairy sector, in chemical processing, in pulp and paper industry, in textiles (Degrémont 2007, 242; Ghosh 2006, 205–206).

Ultrafiltration is used to purify, concentrate or fractionate macromolecules. It refers to scale of separation between microfiltration and nanofiltration. Ultrafiltration is commonly used for separation macromolecules, such as proteins, from the solution. Membranes are usually asymmetrical or composite (Degrémont 2007, 242–243; Ghosh 2006, 205).

Microfiltration is used for separation of fine particles. It is mostly used in clarification, sterilization, and slurry concentration (Degrémont 2007, 243; Ghosh 2006, 205).

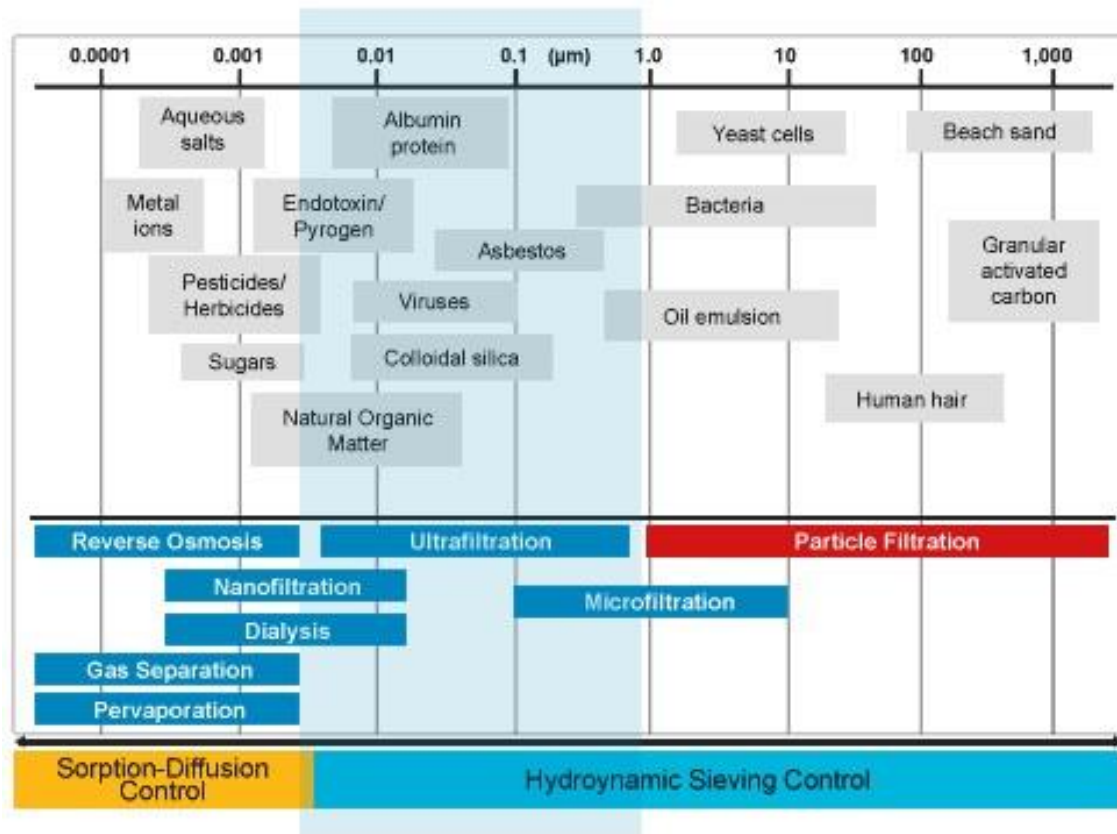

FIGURE 4. Ultrafiltration range (hyfluxmembranes.com)

4.3 Membrane selection

The performance of membrane depends on its properties. The most important are:

- mechanical strength
- chemical resistance
- porosity and pore distribution
- permeability to different species

Membranes are made of polymer. The most common materials are polysulfone and cellulose acetate. Now also thin-film composite ultrafiltration membranes are used. Membrane material should be compatible with chemicals which are used for sanitizing the membranes. (Cheryan 1998, 38)

Basically, membranes for ultrafiltration are chosen according to its molecular cut-off. It is expressed in Dalton (Da) or kilodalton (kDa). For example, membrane with cut-off 5 kDa will retain molecules of that molecular mass and higher and pass smaller molecules. (Millipore 2003, 5)

Ultrafiltration membranes modules can be in plate, spiral-wound and tubular configurations. They can be chosen according its specific application.

Plate type modules (figure 5) consist of a membrane and support plates. These membranes can handle highly viscous products and can be used for high concentrated solutions. (GEA Process Engineering Ltd 2014; Mecadi GmbH, 2008)

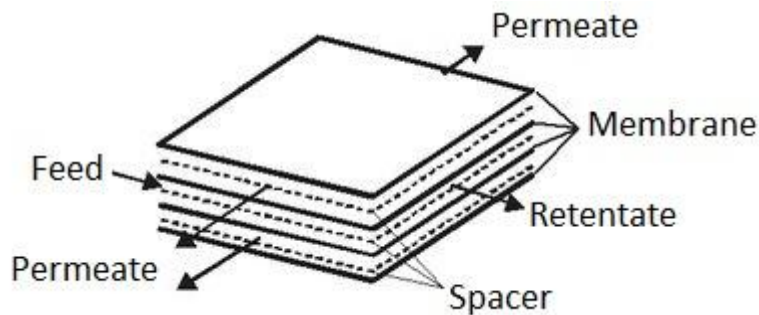

FIGURE 5. Plate-and-frame module (Mecadi GmbH, 2008)

Spiral-wound (figure 6) consists of membrane and permeate carrier wound around permeate tube. This gives very large membrane area with compact structure. Membrane is typically made of polyamide with polysulphone support layer. This kind of membrane is used for achieving high purity. (Degrémont 2007, 885)

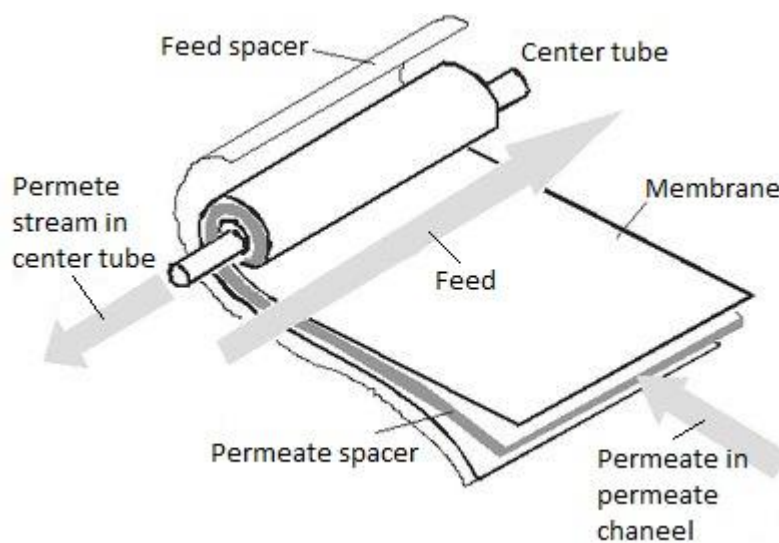

FIGURE 6. Spiral-wound module (Mecadi GmbH, 2008)

In tubular module (figure 7) membranes are placed inside a support porous tube and these tubes are placed together in a cylindrical shell to form a unit module. Tubular devices can handle process streams with high solids and high viscosity properties. (Degrémont 2007, 886)

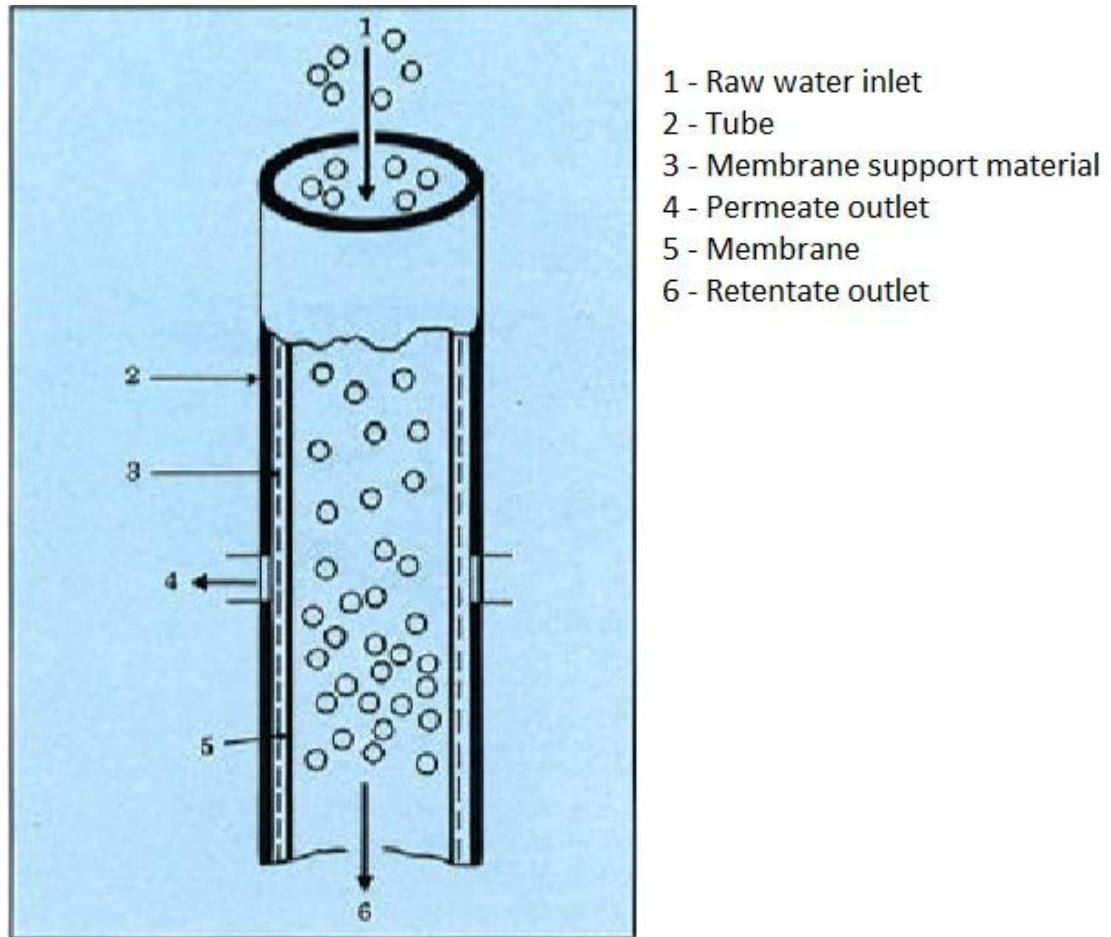

FIGURE 7. Tubular module (Degrémont 2007, 886)

4.4 Diafiltration

As it was said, ultrafiltration is used in purification. But the idea of purification is to decrease salt (low weight compound) concentration, while concentration of protein (high weight compound) should remain the same, so retentate volume should retain the same.

For this purpose diafiltration is used. During diafiltration salts are washing out from the retentate solution by adding pure water at the same rate as filtrate is being generated.

So, retentate volume and protein concentration remain the same and salt concentration is decreasing. The amount of salt removed from the solution is related to permeate volume. This volume is called “diafiltration volume”. Single diafiltration volume (DV) is equal to the initial volume of retentate – when permeate reaches this volume, one DV has been processed. (Schwartz 2003)

So, more DV's were done – higher purity of retentate solution. However, it should be done as least DV's as possible, because the process is time consuming and during the process some protein can be lost, yield is little bit decreasing.

5 EXPERIMENTAL PART

5.1 Measurement of concentration

For monitoring the process concentrations of compounds should be measured.

For salt concentration monitoring conductivity of mixture was measured by conductivity meter. The conductivity of an electrolyte solution is a measure of its ability to conduct electricity. The SI unit of conductivity is siemens per meter (S/m).

For protein concentration monitoring absorbance of 280 nm rays was measured by spectrophotometer. Spectrophotometry is the quantitative measurement of the reflection or transmission properties of a material as a function of wavelength.

5.1.1 Calibration

As far as conductivity and absorbance are not equal to concentration values, calibration was done.

For calibration curves for UV absorbance and conductivity standard solutions of protein and salt were prepared. Concentrations of protein solutions were between 0 and 1,2 g/l and salt solutions between 0 and 30 g/l. Absorbencies of the 280 and 214 nm rays by protein solutions were measured by spectrophotometer, using quartz cuvette, because glass and plastic absorb rays on UV-range. Conductivities of salt solutions were measured by conductivity meter. Calibration curves were drawn (figure 8, 9). The dependence of concentration on conductivity (absorbance) can be described with linear equation. The equation shows relationship between conductivity (absorbance) and concentration. From these equations coefficient can be found for conversion values from measurement to concentration. For absorbance coefficient is 0.586, so, if absorbance is 0.586 – concentration is 1 g/l. For conductivity coefficient is 1.651, so, if conductivity is 16.51 – concentration is 10 g/l. These values are rounded, because of random errors in measurements. In calculation mean values were used.

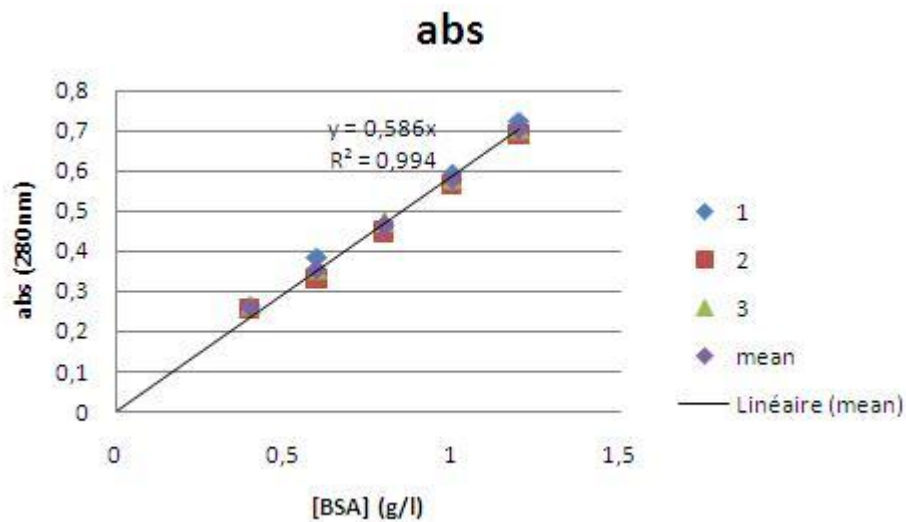

FIGURE 8. Calibration curve for absorbance

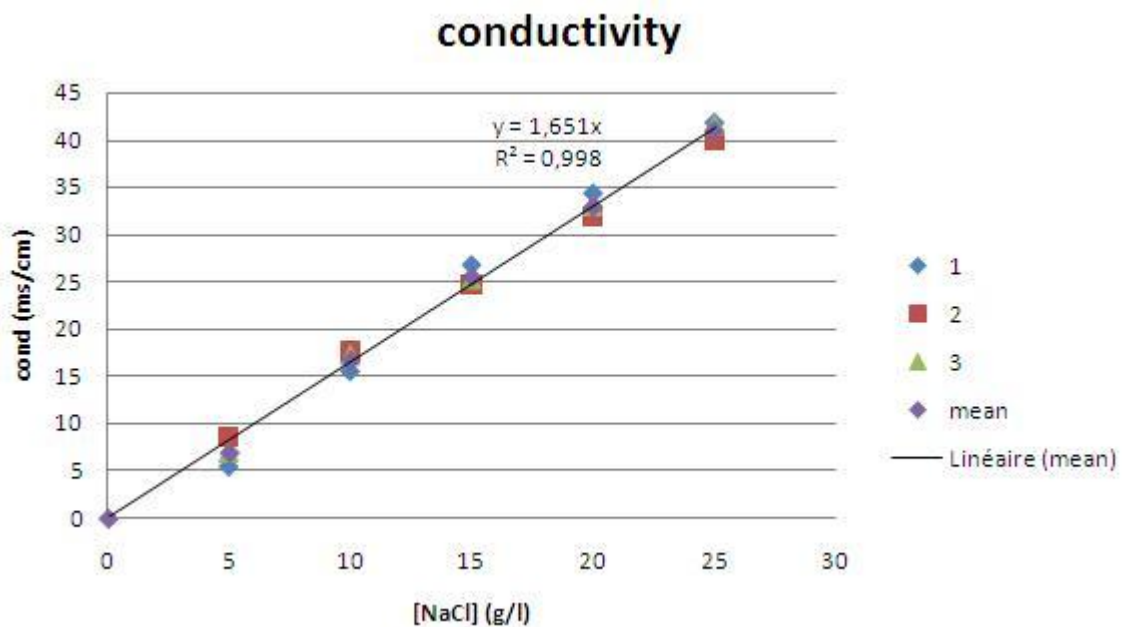

FIGURE 9. Calibration curve for conductivity

5.1.2 Effect of salt and protein concentrations

In order to avoid errors in absorbance and conductivity measurements effect of salt and protein on these measures were checked. NaCl doesn't affect absorbance measurement (figure 10). Because of increase of viscosity BSA and NaCl effect on flow rate on higher concentrations, which were not used in experiment (figures 11, 12). Low concentrations of BSA do not effect on conductivity.

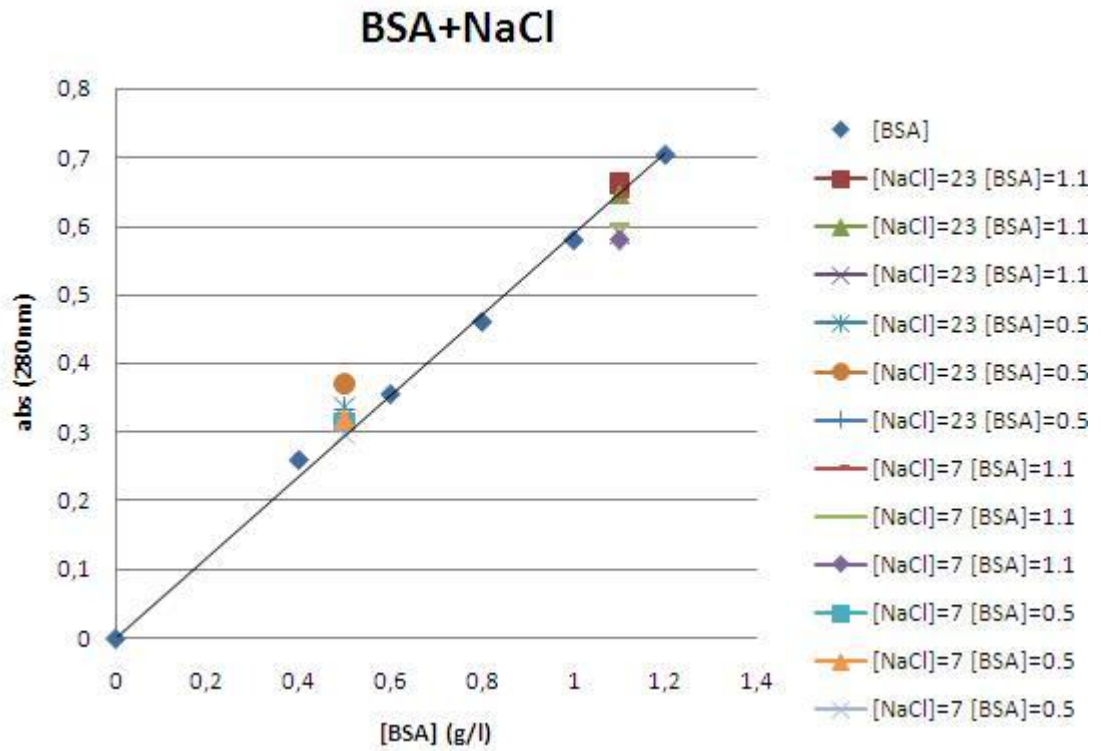

FIGURE 10. Effect of NaCl on absorbance measurement

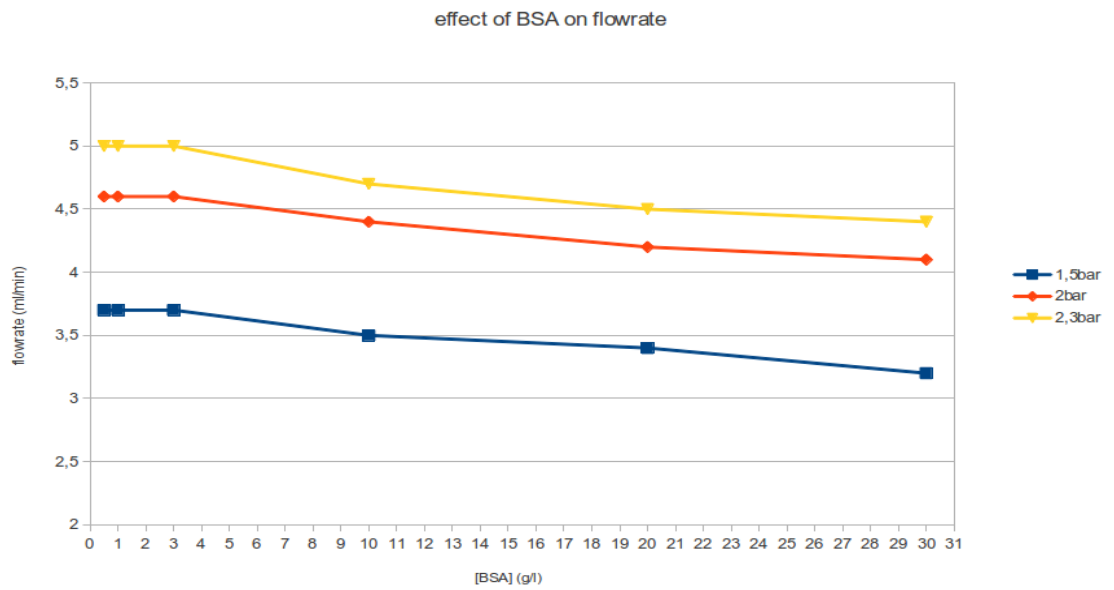

FIGURE 11. Effect of BSA on flow rate

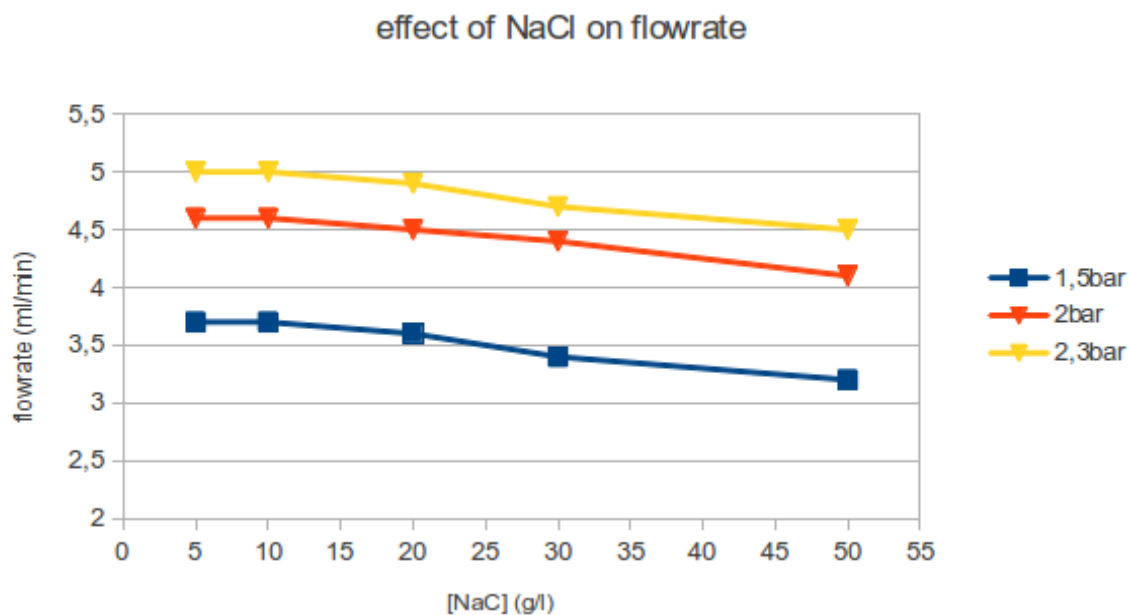

FIGURE 12. Effect of NaCl on flow rate

5.2 Chromatography

The experiment was done using ÄKTA™ Laboratory-scale Chromatography System. At first, column with 16 mm diameter was packed with gel G25. Then, column was connected to chromatography system and protein-salt mixture was injected. Then, chromatography process was run. Finally, chromatograms were obtained. 27 runs with different conditions were done: bed height 2.5, 5, 7.5 cm; injection volume 10, 20, 30 % (of bed volume); flow rate 1, 2, 3 ml/min – these conditions can be used in this chromatography system.

5.3 Filtration

5.3.1 Ultrafiltration

For filtration tangential flow filtration system and 5 kda membrane were used. In filtration salt solution goes to permeate and protein – to retentate. In UF retentate volume was decreasing so that salt concentration remained constant and protein concentration was increasing.

5.3.2 Diafiltration

Diafiltration process is similar with ultrafiltration, but retentate volume remains constant by injecting water, so that protein concentration remained constant and salt concentration was decreasing. DF was done with 1.5, 2, 2.5 bar TMP (transmembrane pressure; only this range of pressure can be reached with filtration system, which was used) with 7 DV (diavolumes). Each time absorbance and conductivity of retentate were measured. Usually, flowrate during run remained constant.

6 RESULTS

Results were obtained both from experiment and simulations (calculations). For evaluation of processes performances were calculated.

6.1 Chromatography

6.1.1 Experimental results

The results are shown in table 3. The table shows time when protein elution starts (T1), time when purities of 99, 95, 90% are reached, time when salt elution ends (T3), time when we can start another run T4 ($T4=T3-T1$) (figure 13), productivity at T4 and yield. It is important to find T4 because for big solution volumes we have to do several runs, and for higher efficiency we can start next run so, that protein elution starts when salt elution ends, without losing time.

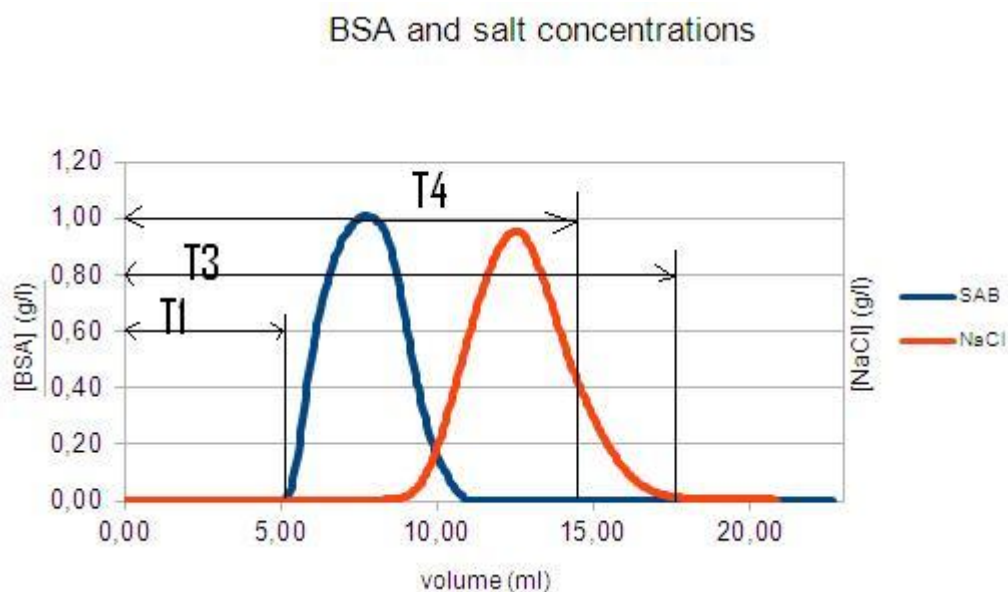

FIGURE 13. Chromatogramme

TABLE 3. Experimental results for chromatography

h (cm)	V (%)	q (ml/min)	EXP									
			T1	T4	T3	prod T4	T 99%	Yield 99%	T 95%	Yield 95%	T 90%	
2.5	10	1	1,00	5,50	6,50	0,01818	2,80	0,95	2,89	0,97	3,00	
2.5	10	2	0,50	2,70	3,20	0,03704	1,33	0,94	1,41	0,97	1,46	
2.5	10	3	0,20	2,60	2,80	0,03846	1,16	0,90	1,26	0,95	1,32	
2.5	20	1	1,00	6,00	7,00	0,03333	2,10	0,41	2,84	0,84	3,03	
2.5	20	2	0,50	3,20	3,70	0,06250	1,37	0,84	1,47	0,90	1,54	
2.5	20	3	0,35	2,15	2,50	0,09302	0,64	0,31	0,91	0,82	0,98	
2.5	30	1	1,00	7,20	8,20	0,04167	2,95	0,73	3,20	0,83	3,32	
2.5	30	2	0,50	3,50	4,00	0,08571	1,37	0,65	1,49	0,75	1,55	
2.5	30	3	0,40	2,30	2,70	0,13043	0,89	0,37	0,96	0,43	1,01	
5	10	1	2,10	8,80	10,90	0,01136	3,60	0,44	4,92	0,97	5,48	
5	10	2	1,20	4,50	5,70	0,02222	2,20	0,82	2,57	0,95	2,81	
5	10	3	0,90	2,90	3,80	0,03448	1,38	0,74	1,71	0,97	1,87	
5	20	1	3,00	9,50	12,50	0,02105	4,95	0,74	5,98	0,97	6,24	
5	20	2	1,00	5,00	6,00	0,04000	1,88	0,32	2,48	0,89	2,62	
5	20	3	0,80	3,70	4,50	0,05405	1,45	0,44	1,82	0,72	1,93	
5	30	1	2,20	11,80	14,00	0,01695	3,67	0,18	5,54	0,74	5,86	
5	30	2	1,20	5,80	7,00	0,03448	1,80	0,14	2,78	0,72	2,95	
5	30	3	0,80	3,80	4,60	0,05263	1,45	0,38	1,86	0,74	1,98	
7.5	10	1	5,00	12,50	17,50	0,00800	7,63	0,75	9,09	0,89	9,77	
7.5	10	2	2,00	6,00	8,00	0,01667	3,19	0,58	3,96	0,88	4,25	
7.5	10	3	1,30	4,20	5,50	0,02381	2,24	0,80	2,69	0,95	2,90	
7.5	20	1	4,00	14,00	18,00	0,01429	6,16	0,39	8,69	0,94	9,20	
7.5	20	2	2,00	7,00	9,00	0,02857	3,32	0,50	4,23	0,89	4,45	
7.5	20	3	1,30	4,70	6,00	0,04255	2,07	0,42	2,79	0,94	2,93	
7.5	30	1	3,90	15,10	19,00	0,01987	4,93	0,71	8,67	0,83	9,05	
7.5	30	2	2,00	8,00	10,00	0,03750	2,71	0,10	4,22	0,74	4,44	
7.5	30	3	1,30	5,60	6,90	0,05357	1,97	0,24	2,80	0,78	2,95	

6.1.2 Simulation results

Simulations were done in program COMSOL. Next data was used: Peclet number of axial dispersion for a solute (depends on column height), porosity of bed (depends on column height), dimensionless time duration for a rectangular (injection volume), Biot number of mass transfer of a solute (depends on accessible particle porosity), dimensionless group (column height, flow rate), accessible particle porosity (depends on column height). Simulation results are shown in table 4.

TABLE 4. Simulation results for chromatography

h (cm)	V (%)	q (ml/min)	SIM									
			T1	T2	T3	prod. T2	T 99%	Yield 99%	T 95%	Yield 95%	T 90%	Yield 90%
2.5	10	1	1.20	5.30	6.50	0.01887	0.86	0.86	2.64	0.95	2.81	0.96
2.5	10	2	0.60	2.50	3.10	0.04000	1.06	0.61	1.23	0.92	1.30	0.95
2.5	10	3	0.40	2.40	2.80	0.04167	0.65	0.36	0.76	0.82	0.82	0.92
2.5	20	1	1.20	5.70	6.90	0.03509	2.37	0.54	2.75	0.85	2.90	0.92
2.5	20	2	0.60	2.90	3.50	0.06897	1.10	0.24	1.28	0.72	1.36	0.85
2.5	20	3	0.50	1.90	2.40	0.10526	0.65	0.18	0.79	0.57	0.85	0.72
2.5	30	1	1.20	6.80	8.00	0.04412	2.37	0.37	2.80	0.64	2.99	0.76
2.5	30	2	0.60	3.10	3.70	0.09677	1.10	0.16	1.28	0.49	1.36	0.60
2.5	30	3	0.50	2.10	2.60	0.14286	0.65	0.12	0.76	0.32	0.94	0.66
5	10	1	2.60	8.40	11.00	0.01190	5.43	0.96	5.95	0.98	6.13	0.98
5	10	2	1.50	4.20	5.70	0.02381	2.63	0.96	2.80	0.97	2.95	0.97
5	10	3	1.00	3.00	4.00	0.03333	1.63	0.95	1.81	0.96	1.87	0.97
5	20	1	2.90	10.10	13.00	0.01980	5.25	0.93	5.78	0.97	6.13	0.97
5	20	2	1.50	4.70	6.20	0.04255	2.63	0.80	2.89	0.93	3.06	0.96
5	20	3	1.00	3.30	4.30	0.06061	1.63	0.64	1.87	0.91	1.95	0.95
5	30	1	2.90	10.10	13.00	0.01980	5.60	0.64	6.30	0.86	6.48	0.91
5	30	2	1.40	6.10	7.50	0.03279	2.28	0.32	2.63	0.54	2.80	0.65
5	30	3	1.00	3.80	4.80	0.05263	1.63	0.43	1.87	0.66	1.98	0.77
7.5	10	1	4.60	11.90	16.50	0.00840	8.95	0.98	9.48	0.99	9.74	0.99
7.5	10	2	2.10	5.90	8.00	0.01695	4.21	0.96	4.48	0.97	4.70	0.98
7.5	10	3	1.50	4.00	5.50	0.02500	2.63	0.95	2.90	0.92	3.00	0.97
7.5	20	1	4.50	13.50	18.00	0.01481	9.22	0.97	9.74	0.98	10.01	0.98
7.5	20	2	2.10	6.90	9.00	0.02899	4.35	0.94	4.61	0.96	4.80	0.98
7.5	20	3	1.50	4.60	6.10	0.04348	2.72	0.86	2.98	0.95	3.10	0.96
7.5	30	1	4.00	15.00	19.00	0.02000	9.22	0.81	9.74	0.91	10.27	0.96
7.5	30	2	2.10	7.90	10.00	0.03797	4.35	0.71	4.74	0.87	4.87	0.92
7.5	30	3	1.50	5.50	7.00	0.05455	2.72	0.59	3.00	0.76	3.16	0.87

6.1.3 Performances

Purity is the absence of impurity or contaminants in a substance. It can be calculated according to equation (1).

$$\text{Purity} = \frac{m_p}{m_s + m_p} \quad (1)$$

Yield is ratio between obtained amount of product and total amount of product. It can be calculated according to equation (2).

$$\text{Yield} = \frac{m_p}{m_{\text{tot}}} \quad (2)$$

Productivity is a measure of efficiency of process. It can be calculated according to equation (3).

$$\text{Productivity} = \frac{m_p}{t \cdot V_{\text{bed}}} \quad (3)$$

Where:

m_p – mass of eluted protein [mg];

m_s – mass of eluted salt [mg];

m_{tot} – mass of total protein [mg];

t – elution time [s];

V_{bed} – bed volume [ml].

Performances in chromatography depend on 3 factors: injection volume, bed height and flow rate. Better peak separation we have with lower injection volume, higher bed height and lower flow rate. Better productivity is with lower bed height, higher injection volume and higher flow rate. The change of performances during the run is shown in figure 14.

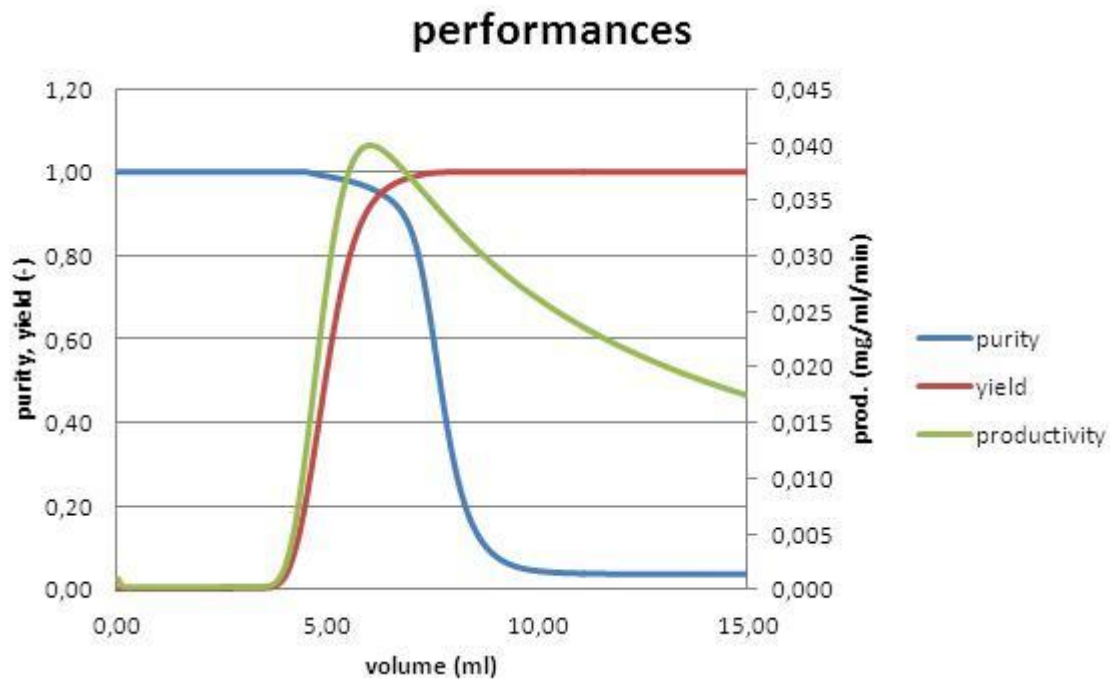

FIGURE 14. Chromatography performances

6.2 Diafiltration

6.2.1 Experimental results

In result tables BSA and NaCl concentrations, productivity, yield and purity are shown (tables 5, 6, 7).

TABLE 5. Experimental results for DF at 1.5 bar TMP

dv	flow (ml/min)	[NaCl] (g/l)	[bsa] (g/l)	TR (bsa)	purity	yield	productivity
0	3.77	26.40	1.01	1.00	0.037	1.000	
1	3.80	9.44	0.97	0.97	0.093	0.957	0.042
2	3.80	3.80	0.96	0.99	0.201	0.946	0.021
3	3.80	1.49	0.94	0.99	0.386	0.928	0.014
4	3.83	0.58	0.91	0.99	0.609	0.898	0.010
5	3.90	0.23	0.90	0.99	0.794	0.889	0.008
6	3.87	0.10	0.89	0.99	0.895	0.879	0.007
7	3.87	0.05	0.89	0.99	0.944	0.878	0.006

TABLE 6. Experimental results for DF at 2 bar TMP

dv	flow (ml/min)	[NaCl] (g/l)	[bsa] (g/l)	TR (bsa)	purity	yield	productivity
0	4.50	28.58	1.12	1.00	0.038	1.000	
1	4.55	10.40	1.02	0.97	0.089	0.904	0.052
2	4.60	4.20	0.98	0.98	0.190	0.876	0.026
3	4.65	1.63	0.98	0.98	0.374	0.871	0.017
4	4.55	0.63	0.96	0.97	0.606	0.858	0.012
5	4.60	0.25	0.94	0.98	0.793	0.840	0.010
6	4.65	0.11	0.92	0.98	0.896	0.816	0.008
7	4.60	0.06	0.90	0.98	0.938	0.797	0.007

TABLE 7. Experimental results for DF at 2.5 bar TMP

dv	flow (ml/min)	[NaCl] (g/l)	[bsa] (g/l)	TR (bsa)	purity	yield	productivity
0	5.50	26.18	1.01	1.00	0.037	1.000	
1	5.55	9.73	0.99	0.99	0.092	0.981	0.062
2	5.60	3.61	0.96	0.99	0.210	0.955	0.031
3	5.65	1.28	0.91	0.98	0.416	0.906	0.020
4	5.65	0.47	0.90	0.98	0.658	0.897	0.014
5	5.65	0.18	0.89	0.98	0.830	0.880	0.011
6	5.65	0.08	0.88	0.98	0.916	0.873	0.009
7	5.60	0.05	0.87	0.98	0.947	0.860	0.008

6.2.2 Calculation

Calculations were done using retention factor TR, which is calculated using experimental values of concentrations according to equation (4). Theoretical retentate concentration was calculated using equation (5).

$$TR = 1 - \frac{C_p}{C_r} \quad (4)$$

$$C_r = C_0 * e^{-(1-TR)*DV} \quad (5)$$

Where:

C_p – protein concentration in permeate [g/l];

C_r – protein concentration in retentate [g/l];

DV – diavolume.

Calculation results are shown in tables below.

TABLE 8. Calculated results for DF at 1.5 bar TMP

dv	flow	[NaCl] (g/l)	[bsa] (g/l)	purity	yield	productivity
0	3.83	26.40	1.01	0.037	1.000	
1	3.83	9.71	1.00	0.093	0.987	0.043
2	3.83	3.57	0.99	0.216	0.975	0.021
3	3.83	1.31	0.97	0.426	0.962	0.014
4	3.83	0.48	0.96	0.665	0.950	0.010
5	3.83	0.18	0.95	0.842	0.938	0.008
6	3.83	0.07	0.94	0.935	0.926	0.007
7	3.83	0.02	0.93	0.975	0.914	0.006

TABLE 9. Calculated results for DF at 2 bar TMP

dv	flow	[NaCl] (g/l)	[bsa] (g/l)	purity	yield	productivity
0	4.59	28.58	1.12	0.038	1.000	
1	4.59	10.51	1.10	0.095	0.977	0.057
2	4.59	3.87	1.07	0.217	0.955	0.028
3	4.59	1.42	1.05	0.424	0.933	0.018
4	4.59	0.52	1.03	0.662	0.912	0.013
5	4.59	0.19	1.00	0.839	0.892	0.010
6	4.59	0.07	0.98	0.933	0.871	0.009
7	4.59	0.03	0.96	0.973	0.852	0.007

TABLE 10. Calculated results for DF at 3.5 bar TMP

dv	flow	[NaCl] (g/l)	[bsa] (g/l)	purity	yield	productivity
0	5.61	26.18	1.01	0.037	1.000	
1	5.61	9.63	0.99	0.093	0.984	0.063
2	5.61	3.54	0.97	0.216	0.968	0.031
3	5.61	1.30	0.96	0.424	0.953	0.020
4	5.61	0.48	0.94	0.663	0.938	0.015
5	5.61	0.18	0.93	0.840	0.923	0.012
6	5.61	0.06	0.91	0.934	0.908	0.010
7	5.61	0.02	0.90	0.974	0.893	0.008

6.2.3 Performances

Purity is the absence of impurity or contaminants in a substance. It can be calculated according to equation (6).

$$\text{Purity} = \frac{m_p}{m_s + m_p} \quad (6)$$

Yield is ratio between obtained amount of product and total amount of product. It can be calculated according to equation (7).

$$\text{Yield} = \frac{m_p}{m_{\text{tot}}} \quad (7)$$

Productivity is a measure of efficiency of process. It can be calculated according to equation (8).

$$\text{Productivity} = \frac{m_p}{t \cdot A_{\text{mem}}} \quad (8)$$

Where:

m_p – mass of eluted protein;

m_s – mass of eluted salt;

m_{tot} – mass of total protein

t – elution time;

A_{mem} – surface area of membrane.

In UF performances depend on TMP and diavolume. Higher TMP – better performance, but with increasing of diavolumes productivity is decreasing. Figure 15 shows the change of performances during the run.

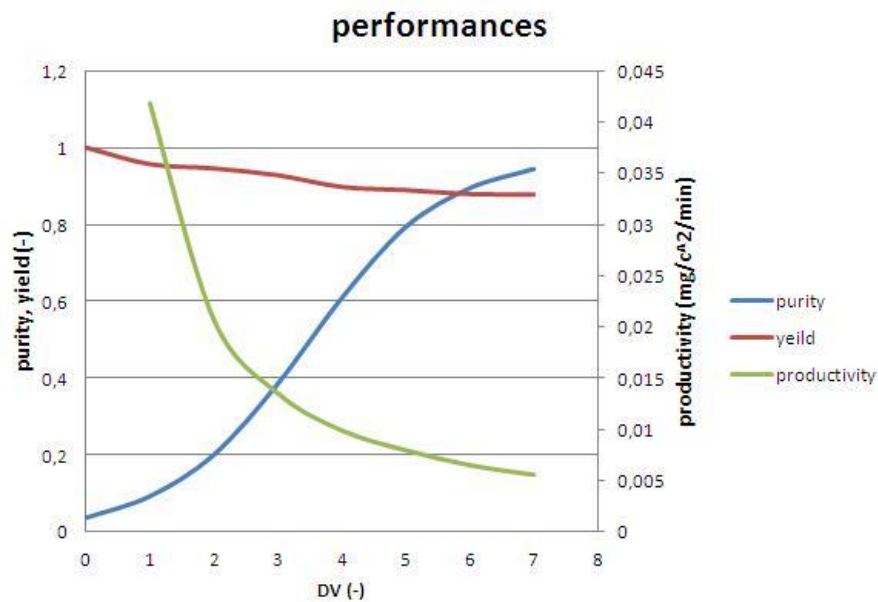

FIGURE 15. DF performances

7 DISCUSSION

For comparison of SEC and DF the best its conditions were used. For SEC it was the highest productivity for the moment of starting a next run and yield $>90\%$ on purities of 90, 95, 99%. For DF it was the highest productivity, which was reached with highest TMP – 2.5 bar. For SEC conditions $h=5\text{cm}$, $v=10\%$, $q=3\text{ml/min}$ was chosen (results are in TABLE 3), for DF – 2,5bar TMP (results are in TABLE 7). For calculation of duration of treatment in SEC productivity at the moment of next run was used, for DF – flow rate and DV on desired purity. For treatment of 1000 ml of solution SEC requires 2886 minutes (figure 16).

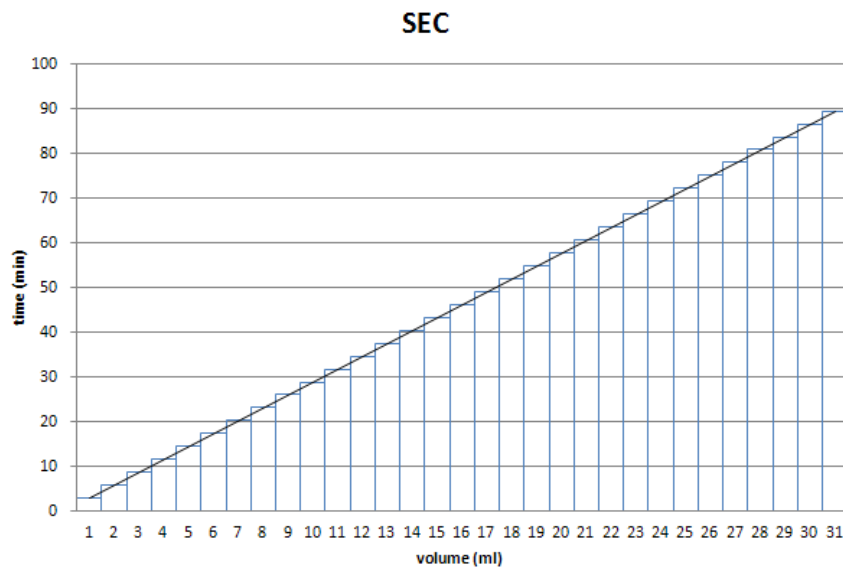

FIGURE 16. Time required for treatment of certain volume by SEC

For treatment of 1000ml of solution by DF: 90% purity – 980 min, 95% purity - 1114 min, 99% purity - 1381, but with 99% purity yield is less than 90%, maximal purity which can be reached with yield 90% - 97% - 1203 minutes (FIGURE 17).

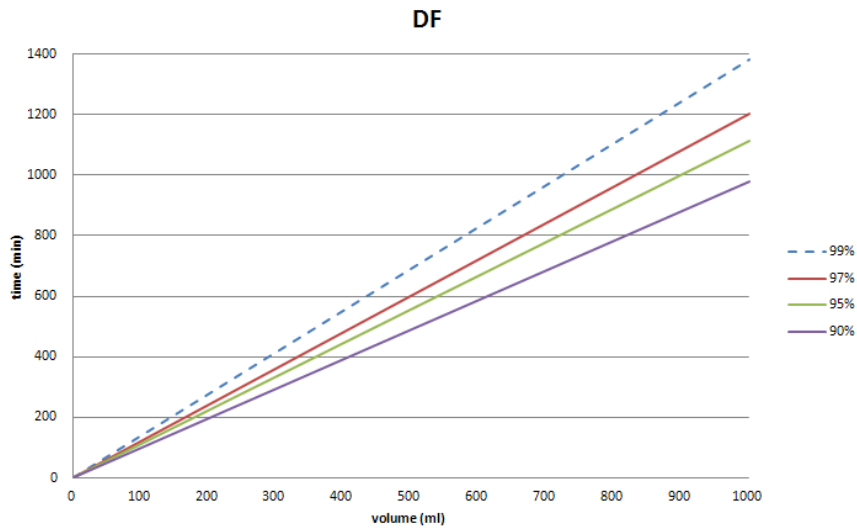

FIGURE 17. Time required for treatment of certain volume by DF

One run (1 ml volume) for SEC requires 3.8 min, when with DF less than 1.3 min. So, it is better to use DF for purity range lower 97%, but SEC for purity higher 97% (figure 18).

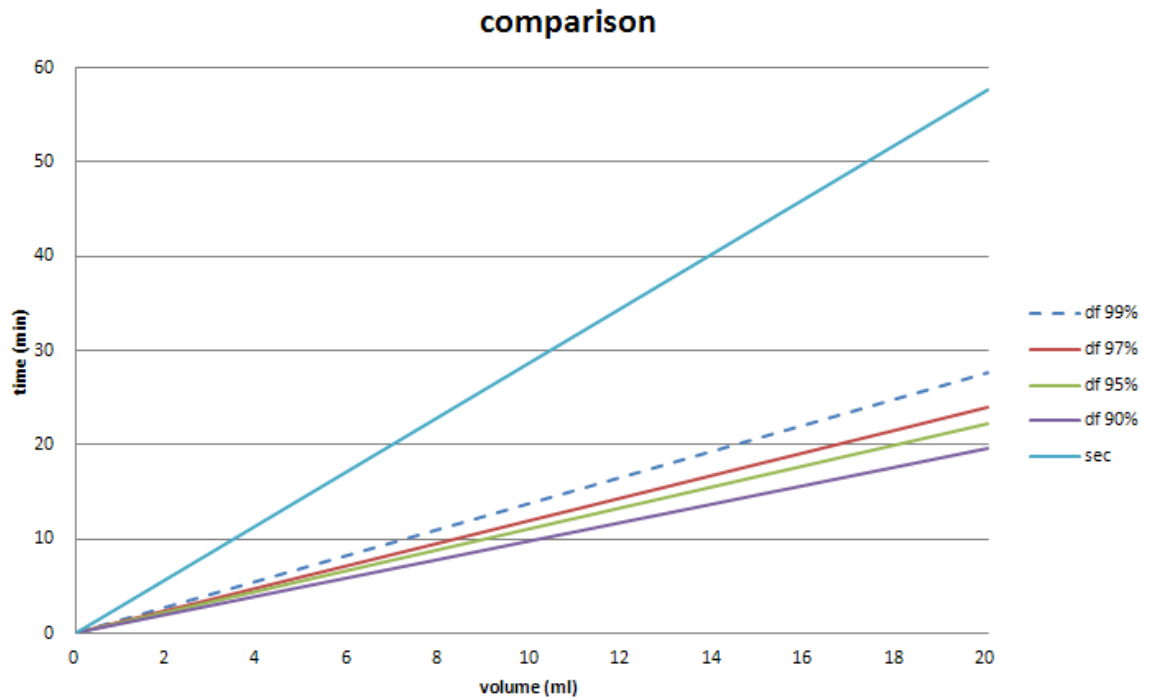

FIGURE 18. Comparison of SEC and different purities DV's

REFERENCES

Amersham Biosciences. 1998. Desalting and buffer exchange with Sephadex® G-25. Application Note. Sweden: Wiikströms.

Avista Technologies. Membrane Construction. Read. 03.04.2014.
http://www.avistatech.com/Solutions/membrane_construction.htm

Barry E.F. & Grob R.L. 2004. Modern Practice of Gas Chromatography. Pennsylvania.

Cheryan Munir. 1998. Ultrafiltration and Microfiltration Handbook. Florida: CRC Press LLC.

Degrémont. 2007. Water Treatment Handbook. Paris: Lavoisier.

Dhawan G. About Ultrafiltration. Read 15.03.2014.
http://www.appliedmembranes.com/about_ultrafiltration.htm

Dolan J.W., Kirkland J.J. & Snyder L.R. 2010. Introduction to Modern Liquid Chromatography. New Jersey: John Wiley & Sons, Inc.

EMD Millipore. Filtration Basics. Read 15.03.2014.
http://www.millipore.com/membrane/flx4/filtration_basics_hm&tab1=3&tab3=1#tab1=1:tab3=1

Fried B. & Sherma J. 1999. Thin-Layer Chromatography, Revised and Expanded. New York: Marcel Dekker, Inc.

GE Healthcare Handbook. 2006. Hydrophobic Interaction and Reversed Phase Chromatography. Principles and Methods.

GE Healthcare Handbook. 2010a. Gel Filtration. Principles and Methods

GE Healthcare Handbook. 2010b. Strategies for Protein Purification

GE Healthcare Handbook. 2012. ÄKTA™ Laboratory-scale Chromatography Systems. Instrument Management Handbook.

GEA Process Engineering Ltd. Plate and Frame Filters. Read 03.04.2014.
<http://www.geap.co.nz/NNZ/cmsdoc.nsf/webdoc/ndkw73fcjt>

Ghosh R. 2006. Principles of Bioseparations Engineering. Singapore: World Scientific Publishing Co.

Harvard Apparatus. Guide to Gel Filtration or Size Exclusion Chromatography.

Hedhammar M., Hober S. & Eriksson A. Chromatographic Methods for Protein Purification. Royal Institute of Technology, Alba Nova University Center, Dept. of Biotechnology. Stockholm.

Hyflux Membranes ®. 2008. Ultrafiltration (UF). Read 15.03.2014.
<http://www.hyfluxmembranes.com/ultrafiltration.html>

Hyflux Membranes ®. Tubular Membranes. Read 03.04.2014.
<http://www.hyfluxmembranes.com/tubular-membranes.html>

Iritani E., Katagiri N. & Mukai Y. 2003. Development of Desalination and Concentration Process of Protein Solutions with Superabsorbent Hydrogels. Annual Research Report. Nagoya University.

Janson J.-C. 2011. Protein Purification: Principles, High Resolution Methods, and Applications. New Jersey: John Wiley & Sons, Inc.

Mecadi GmbH. 2008. Technology Report. Gas Separation with Membranes.

Millipore. 2003. Technical Brief. Protein Concentration and Diafiltration by Tangential Flow Filtration.

Millipore. 2008. Cogent® µScale Tangential Flow Filtration System User Guide.

Mori S. & Barth H.G. 1999. Size Exclusion Chromatography. Germany: Springer-Verlag Berlin Heidelberg.

Pharmacia Biotech. Sephadex®G-25 media and pre-packed columns. Desalting/buffer exchange and gel filtration gel. Uppsala: Wiikströms.

Phillips T. Methods for Protein Purification. Read 20.04.2014
<http://biotech.about.com/od/protocols/a/ProteinPurify.htm>

Safe Drinking Water Foundation. Ultrafiltration, Nanofiltration and Reverse Osmosis. Read 17.03.2014. <http://www.safewater.org/resources/fact-sheets.html>

Schwartz L. 2003 Diafiltration: A Fast, Efficient Method for Desalting, or Buffer Exchange of Biological Samples. Pall Life Sciences Scientific & Technical Report.

Scott R.P.W. 1995. Techniques and Practices of Chromatography. New York: Marcel Dekker, Inc.

Sutherland K. 2009. What is Nanofiltration? Read 17.03.2014
<http://www.filtsep.com/view/717/what-is-nanofiltration/>

Tosoh Bioscience LLC. General Principles of Liquid Chromatography. Read 10.03.2014. http://www.separations.eu.tosohbioscience.com/NR/rdonlyres/D3985808-D7DB-4FCF-8868-EDB7FEE150B5/0/P10L01A_ModePoster.pdf

Tosoh Bioscience LLC. Principles of Ion Exchange Chromatography. Read 05.03.2014. <http://www.separations.us.tosohbioscience.com/ServiceSupport/TechSupport/ResourceCenter/PrinciplesofChromatography/IonExchange>

World Health Organization. 2014. The International Pharmacopoeia. Chromatography. Read 28.04.2014. <http://apps.who.int/phint/en/p/docf/>

Wu, C.-S. 1995. Handbook of Size Exclusion Chromatography and Related Techniques. 2nd edition. USA: Marcel Dekker, Inc.