



**TECHNICAL AND ECONOMIC
FEASIBILITY OF DEMOUNTABLE
BUILDING CONCEPTS**

Tom Depypere

Master's thesis
May 2015
Degree Programme in
Construction Engineering

TAMPEREEN AMMATTIKORKEAKOULU
Tampere University of Applied Sciences

ABSTRACT

Tampereen Ammattikorkeakoulu
Tampere University of Applied Sciences
Degree programme in Construction Engineering

TOM DEPYPERE

Technical and Economic Feasibility of Demountable Building Concepts

Master's thesis 94 pages, appendices 17 pages
May 2015

The construction industry has a substantial influence on the environment by using a lot of raw materials, consuming a lot of energy and producing an immense amount of construction and demolition waste. Today, sustainability becomes more and more important, and there is a growing awareness that our ecological footprint should be reduced. The growing world population engages us to deal more efficiently with a lot of things. Housing is definitely one of the most important issues to go about. Space is becoming more and more valuable, but living facilities at present are not sustainable nor flexible.

Using new raw materials could be avoided if construction elements could be reused as a whole. This could be considered as a way of “urban-mining”. To achieve this, changes are necessary in the present way of constructing, taking a lot of factors into account. By thoroughly analysing the present prefabrication industry and how it has evolved over the last years, a demountable building concept has been developed. The proof of this concept should be tested with a prototype. Not only the way of constructing changes when it is the aim is to make a building demountable, but also the design and calculation method for these structures.

Using a building information modeling tool, the whole concept can be made possible. All relevant information about every construction component can be stored in the models. By using demountable building, the use of new raw materials can be cut down and more flexible buildings can be achieved.

Key words: demountable building, sustainable material cycles, prefabrication

ABSTRACT (in Dutch)

Tampereen Ammattikorkeakoulu
Tampere University of Applied Sciences
Degree programme in Construction Engineering

TOM DEPYPERE

Technical and Economic Feasibility of Demountable Building Concepts

Master's thesis 94 pages, appendices 17 pages
May 2015

De bouwindustrie heeft een aanzienlijke invloed op het milieu. Enerzijds door het grote verbruik van grondstoffen en energie, anderzijds door het produceren van grote hoeveelheden bouwafval. Duurzaamheid wordt de dag van vandaag steeds belangrijker en het besef dat de mensheid zijn ecologische voetafdruk moet verkleinen, groeit gestaag. Het feit dat de wereldbevolking steeds toeneemt, legt ons op om efficiënter om te springen met heel wat zaken. Een van die zaken is voorzieningen voor zowel wonen als werken. De beschikbare ruimte wordt steeds kostbaarder, maar de hedendaagse voorzieningen zijn vaak niet duurzaam, noch flexibel.

Het gebruik van verse grondstoffen zou vermeden kunnen worden als bouwelementen in zijn geheel hergebruikt worden. Dit kan beschouwd worden als een vorm van “urban mining”. Om dit te bereiken, zijn veranderingen in de hedendaagse bouwwijzen nodig, waarbij met heel wat factoren rekening gehouden dient te worden. Door het analyseren van de hedendaagse prefab-industrie en haar recente evolutie kon een demontabel bouwconcept worden ontwikkeld. Dit concept dient getest te worden aan de hand van een prototype. Wanneer een gebouw ontworpen wordt om demonteerbaar te zijn verandert niet enkel de bouwwijze, maar ook het ontwerp en de berekeningsmethode.

Door het gebruik van een bouwwerkinformatiemodel (building information model) kan het hele concept mogelijk gemaakt worden. Alle relevante informatie over de bouwelementen kan opgeslagen worden in het model. Door het gebruik van demontabele bouwconcepten kan de grondstoffenconsumptie verminderd worden en kunnen flexibelere gebouwen gerealiseerd worden.

Kernwoorden: demontabel bouwen, duurzame materiaalkringlopen, prefab-industrie

CONTENTS

1	INTRODUCTION.....	6
2	RESEARCH QUESTION	8
3	METHODOLOGY	11
4	THE NECESSITY OF DEMOUNTABLE BUILDING.....	13
4.1	Historical background	13
4.2	Problems	14
4.2.1	Resources and waste	14
4.2.2	Flexibility	17
4.2.3	Energy regulations	19
5	PREFABRICATED BUILDING	20
5.1	What is prefabricated building?.....	20
5.1.1	Advantages	21
5.1.2	Challenges	22
5.2	Mixed construction	22
5.3	Types of precast concrete structures	22
5.4	Joints and connections.....	24
5.5	Modular building	25
6	DEMOUNTABLE BUILDING.....	26
6.1	The idea	26
6.2	SWOT-analysis.....	27
6.3	Urban mining	28
6.3.1	Definition	28
6.3.2	History.....	29
6.3.3	SWOT-analysis.....	30
6.3.4	Different categories	31
6.3.5	RAU	33
6.4	Existing systems	35
6.4.1	Patents	35
6.4.2	PRESSS.....	35
6.5	Examples	38
6.5.1	Parking garage.....	38
6.5.2	Extensible company building	40
7	A DEMOUNTABLE BUILDING CONCEPT.....	43

7.1	General concept	43
7.2	Joints and connections.....	43
7.3	Construction elements	47
8	TECHNICAL BARRIERS	49
8.1	Joints and construction elements	49
8.1.1	Stiffness of the joints: influence on the calculation method	49
8.1.2	Fire resistance.....	54
8.2	Selective demolition.....	56
8.3	Transport, storage and database.....	57
8.3.1	Transport	58
8.3.2	Storage	58
8.3.3	Database	58
8.4	Quality loss	59
8.4.1	Concrete	59
8.4.2	Steel	60
8.4.3	Wood.....	60
9	BUILDING INFORMATION MODELING	61
9.1	Definition.....	61
9.2	Common features of BIM.....	61
9.3	Required features of a BIM drafting system	62
9.4	The importance of BIM for demountable building concepts	62
9.4.1	Characteristics of the elements.....	63
9.4.2	Transferring the information	64
9.4.3	Example in Tekla BIMsight	64
10	ECONOMIC BALANCE	67
10.1	Parameters	67
10.1.1	Salaries	68
10.1.2	Raw materials	69
10.1.3	Preparations and planning	70
10.1.4	Equipment, machinery, design and facilities	70
11	DISCUSSION	71
	REFERENCES	73
	LIST OF PICTURES	75
	LIST OF FIGURES	76
	LIST OF TABLES	77
	APPENDICES	78

1 INTRODUCTION

The construction industry has a substantial influence on the environment by using a lot of raw materials, consuming a lot of energy and producing an immense amount of construction and demolition waste. Over the last decades, sustainability has become more and more important. There is a growing awareness that our ecological footprint should be reduced. There are several ways to achieve this. One of those ways is to deal more efficiently with raw materials, since they are a crucial factor in the construction industry. They are expensive and often need to be imported. This raises their cost and is also not sustainable at all. In Flanders, it is estimated that 75% of the raw aggregates and construction sand needs to be imported. Recycling materials can be a solution, but there will always be a certain loss of quality in products that are made with recycled materials. This loss could be avoided if components are re-used as a whole, as a form of “urban-mining”. To achieve this, a change in the way of constructing is necessary, but there is a lot more to take into account, such as the design and calculation methods. (De Ridder, Goeminne, Mazijn, Vanhoutte, Backaert, De Mol & Van Roo, 2002, 21)

The world population has been increasing significantly over the last few decades, and this growth will keep going for some more time. From 1950 to 2050, the world population will have grown from approximately 2,5 billion to 9,5 billion. This forces us to deal more efficiently with a lot of things and find effective solutions to new challenges. One of those challenges is to give every human being his own space to live. Space is becoming more and more valuable, and present living facilities are often not sustainable. Buildings are one of the primal needs of human beings, but the way that humans think about them has not changed much for a long time. The Dutch architectural team RAU, led by Thomas Rau has a clear and interesting opinion on buildings. They pose that humans are not really interested in the building itself, but in the function that it provides them. It fulfils their needs for a certain time, but at some point that will be over and the building will not be relevant anymore. All that is left then is a huge pile of materials that have no use anymore. This represents the current linear economy, which RAU wishes to break away from. They want to evolve to a circular economy, which is more sustaina-

ble. That is why they design buildings as raw material depots in which the raw materials are stored temporarily. After the user of the building is not interested in its function anymore, the materials can go back into the circuit to be reused and fulfil another purpose. For this to be possible, the raw materials should be dealt with wisely. One way to achieve this circular economy, is recycling the materials after demolition. Although the properties of recycled building materials are not at all bad, it is practically impossible to obtain the same quality with this way of working. A different solution could be to develop demountable building concepts. That way, the materials do not lose their quality and are reused as a whole element. In chapter six, more can be read about the vision of RAU. (World Population 2014, RAU)

In this thesis, it is investigated how this way of constructing could be achieved. It is important to determine and clarify what the technical and economic barriers are and what the impact on a lot of different levels could be.

2 RESEARCH QUESTION

The main research question is the following: What is the technical and economic feasibility of demountable building concepts? Demountable building has been talked about for a few decades already, but there has not been a massive breakthrough. In this thesis, the reason for that has been investigated and an analysis was made of how demountable building can be made more attractive as a building technique of today and tomorrow.

To provide an answer on this main research question, some other minor questions had to be answered first.

First of all, it is a necessity to determine the background. It is important to get an impression of the present way of building and pointing out the hazards it implies. Demountable building can resolve some of those hazards, but also will imply new issues. The advantages and disadvantages should be kept in mind. The first part of the thesis will focus on the growing waste problems. By giving more thought to detailing the construction, the on-site waste can be reduced, and waste at the end of the lifecycle of the building has ended. Reducing by reusing and/or recycling are the keywords here.

There are several ways of constructing, mostly depending on the materials and the structure that is used. The most popular structural building materials that are used nowadays are the following:

- Concrete
- Steel
- Wood

Next to that, there are three different kinds of structures that are applied in construction, which are the following:

- Skeletal structure
- Wall frame structure
- Portal structure

Some materials and structures go hand in hand. Steel works good for the skeletal structure, while concrete will be more suitable for a wall frame structure. Demountable building is more evidently when steel is used, but since concrete is by far the most used construction material, it is interesting and necessary to dig into this as well. What also will be discussed is the present day techniques of demountable buildings. Where is it been done already? What were the biggest challenges?

Secondly, there is the technical side of the story. Demountable building concepts are a rather new development in the construction world. This means that there is not much research been done on the subject and that there are no real experts. It is important to determine some of the technical challenges that will occur. The way of constructing will differ a lot from the classic methods. Special attention should be given to how everything is assembled. Can the joints be stiff enough and still be demountable? How can this be done? How will the building be dismantled at the end of its lifetime or user-time? Is this technically and economically possible?

Urban mining can be defined as the process of reclaiming compounds and elements from products, buildings and waste. This is a definition of what urban mining means, but in fact it is about changing our view on materials and in this case also buildings. The vision of RAU, as described earlier, aligns with the concept of urban mining. To get a full understanding of what urban mining really means, a lot of attention is given to it, since it is the guideline that is used for demountable building. Another question that poses itself is what happens with the building elements when the building is demounted. Where and how can they be stored, and how will a third party get to know that there are construction elements available? The idea of building an online database/stock-exchange for building components is introduced here.

Something else that is important to demountable building concepts is the quality of the materials during their lifecycle. Since concrete is an elasto plastic material, it won't behave in the same way as steel. How many times can a beam or a column be reused before becoming insufficient? And how can this be determined? All of the topics above circle around the central question, which is: "Can it be done?"

Thirdly, it is obvious to take a look at the sustainability and the economic feasibility of demountable building. It is necessary to investigate if demountable building is really more sustainable than the classical way of building. Since a different calculation method will be used, there will also be a difference in the inner structure of the elements. Of course there will be a saving in new raw materials and energy to fabricate the elements, but on the other hand there will be extra costs for demounting, storing and transport. Comparing the building methods with each other on a lot of levels should give some insight in the possible benefits and hazards.

A rising item in the world of construction is Building Information Modeling, commonly abbreviated as BIM. Also for demountable building concepts, BIM can be the tool to make the whole process easier. One of the challenges is that it is important to keep track of all the information of fabricated elements. By storing information about every building component in a BIM, this data does not get lost anymore, which is important when talking about reusing.

3 METHODOLOGY

Demountable building concepts are not common nowadays. It is a rather new development in the construction world to design buildings that also can be taken apart again. The main goal of this thesis tri-fold. The first aim is to gather information about related systems that exist nowadays. Secondly, it is important to define the difficulties that can occur, both technically and economically. At last, the purpose is to give suggestions for new research and development on the subject.

The subject of demountable building concepts is very wide. It was necessary to set boundaries for the research. By doing an initial brainstorm, a mind map was drawn with the most important topics to dig into. FIGURE 1 shows this mind map. The main topics could be further divided, since a lot of the related topics can be very extended. However, it was important to stay close to the initial research question.

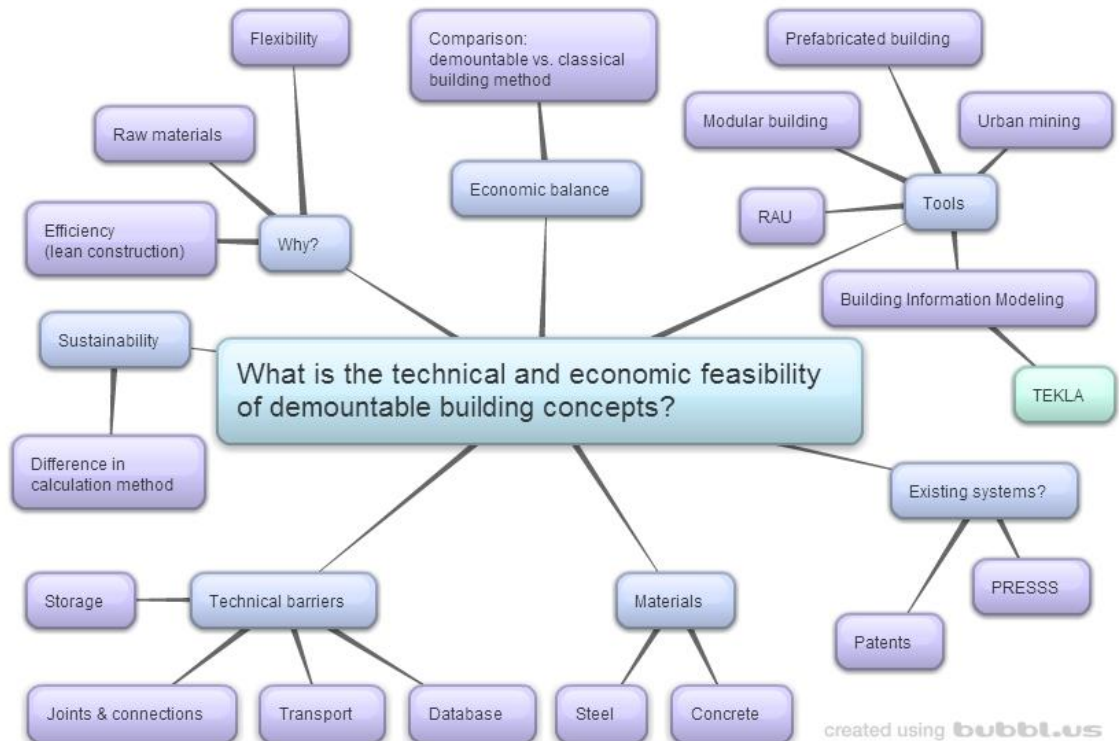

FIGURE 1. Mind map

Most of the research for this thesis existed of searching information in literature, magazines and electronic sources. Discussing the subject with colleague students, experienced professionals and teachers also lead to new insights. By doing surveys and company visits, more information was gained about the present situation and vision towards sustainability in the construction world nowadays. To be able to comprehend the concept of Building Information Modeling, it was necessary to experiment with the fitting software packages, which were Tekla Structures and mostly Tekla BIMsight. Since these software packages are used for real projects, they are very extended. Due to short time, it was only possible to get a grip on the basics of it.

Developing a demountable building concept is not evident, but this thesis would not be complete without a suggestion of how it can be done. The result is based on existing systems, but should be developed further and tested thoroughly before applying it in real life. This was beyond the objectives and possibilities of this thesis. A lot of ideas are presented about how the industry has to evolve and what tools can be used to make it work. These ideas are no exact science and are roughly state, based on studied hypotheses, serving as a stepping stone for further development.

4 THE NECESSITY OF DEMOUNTABLE BUILDING

4.1 Historical background

Every building has a certain life span. Whether it is thirty, fifty or a hundred years, it is meant to last for quite a long time. Since the earth has been changing a lot in the recent past due to human impact, climate change, variable weather patterns and so on, it is not at all certain that our buildings will be adapted to the conditions in the future and that they can live up to the expectations by then. Buildings manufactured in the 1970's are growing outdated today, and in a fast evolving world it is to be expected that even our most recent buildings won't be able to cope with the standards of the next decades.

Ancient civilizations initiated the concept of reusing. Old cities, like Troy, were often built upon the ruins of other destroyed cities. Houses were made out of the rubble. Romans made a lot of their constructions out of rubble that was present at the construction site, combined with furnace blast and pozzolan, which is the binding factor for the latent hydraulic material (furnace blast). This was a cheap and fast way of building and represents the origin of concrete. For example the Pantheon in Rome, built in circa 120 A.D. was built with a material that can be classified as concrete. The outer side of the walls was built out of masonry, serving as the mould for the concrete. Another function of the brick wall was to hold up the structure while the concrete hardened, which took a longer time than nowadays due to the primitive method that was applied. The space in between the brick walls was filled with rubble, strengthened with pozzolan and lime. This resulted in a wall of 6,2 m thick on the bottom, narrowing a little to the top, which holds up a dome with a radius of 43 m. This "concrete" had a compressive strength of 5 N/mm². At the time that was quite impressive and since the Pantheon is still there today, it is also proven to be effective. What should be noticed, is that the building material consisted of random materials, amongst them also waste products. Rubble was used in a successful way to create a new structure. This proves that the idea of reusing is just common sense, and not an artificial way of thinking. (Roman Concrete 1999)

4.2 Problems

4.2.1 Resources and waste

Construction requires a lot of resources. Machines need to be powered with electricity or fuel, equipment has to be transported to the construction site, raw materials are essential and water supply is highly necessary for a lot of building processes. Resources are not infinite. They can and eventually will run out if they are not dealt with wisely.

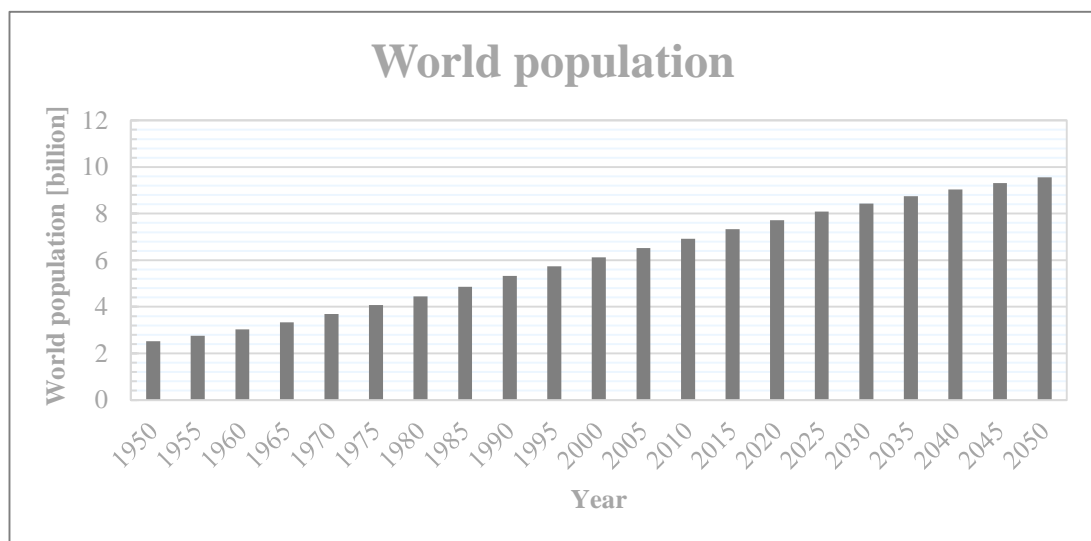
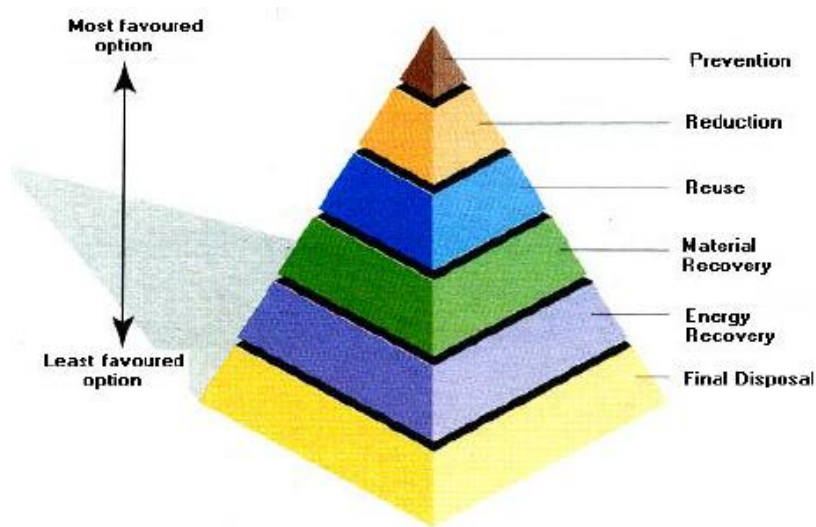

FIGURE 2. World Population (World population 2014)

As shown in figure 1, the world population has been increasing significantly since the end of the second world war. Every living person generates a certain amount of waste. More people equal more waste, and this has resulted in a growing waste problem after the 1970's. There was no such thing as policies on waste and environmental problems were not an issue. Disposal and incineration were the usual ways to deal with waste. On the ladder of Lansink, the common ranking system of how to deal with waste, those two options are at the bottom, which means that they are the least favourable. The ladder of Lansink is thoroughly explained further on in this chapter. Since the space of living decreases as the world population grows, people realized that sustainability is important, certainly because the end of the population growth is not in sight yet. In Flanders, the OVAM (Eng: Flemish Public Waste Agency) published some brochures and research

results on construction and demolition waste in the nineties. New decrees were installed and the regulations became more tight. However, focusing on how to deal with waste is not the solution to the problem. The waste problem relates to a lot of factors, such as consumption patterns, lifestyle and the way of thinking about materials. An effective waste management starts with prevention: what is not produced does not need to be disposed of.

The construction industry is responsible for the use of a big amount of the world's natural resources. This need for raw materials is a burden for the environment. First of all because taking out resources changes the landscape, but most of all because transporting them to the construction site costs a lot of energy. In order to preserve the environment, new regulations on mining resources were installed. For example, the Belgian government decided that mining gravel from the riverbed was prohibited from 2006 on. As an unwanted result of those regulations, approximately 75% of the aggregates for the building industry in Flanders is imported, hence the environmental burden. (De Ridder, Goeminne, Mazijn, Vanhoutte, Backaert, De Mol & Van Roo, 2002, 21)



PICTURE 1. Ladder of Lansink (Hansen, Christopher & Verbuecheln 2002, 4)

The Ladder of Lansink, as shown on picture 1, shows what the options to deal with waste are, and ranks them from most to least favourable. The best option is prevention: when no waste is produced, there is none to be disposed of. Prevention results in the

least environmental or economical cost, since there is no material to be collected and processed. Obviously, reduction of the amount of waste is on the second place. The next most desirable option is reuse. Using a material again without making any structural changes to it, requires little processing. Recovery of material or energy is the next option, chosen by which one has the least impact on the environment and human health. Most of the time, recovery of materials comes before recovery of energy, which is often incineration. Final disposal, by which often landfilling is meant, is the least favourable option. Landfilling is obviously a last resort when all other options have been considered and not have been found appropriate. Although landfilling spots are well designed and engineered, this option has the biggest impact on the environment. This is because it takes up space and changes the landscape, but also because the possibility exists that the soil, air or groundwater gets polluted by substances in the waste materials.

Over the last few decades, recycling has become a hot topic. Also in the construction industry, efforts have been made to work in a more sustainable way. In Belgium, 10 million tons of aggregates is recycled each year. That is a big amount of material that does not need to be excavated anymore. A lot of research has been done on how to recycle concrete aggregates, what the possibilities are and how it affects the characteristics of the recycled concrete. Although the quality of recycled concrete is not bad at all, the present view on how to deal with the recycling of concrete is perhaps not the best. Making recycled concrete is a good idea, but there will always be a certain quality loss. The applications in which it is used are often of a lower quality than before, like foundations for road works, resulting in a downcycling action. Since material recovery is one step higher up the ladder of Lansink than disposal and incineration (or energy recovery), there is some progress but it might be possible to climb even another step higher on the ladder. If the reusing of elements as a whole and not the aggregates of demolished elements becomes a current procedure, the loss of quality is avoided. This could be the fact for columns, beams, walls... In the construction industry, the highest step (prevention) cannot be achieved. However, making the reuse of building components a more standard procedure could mean a big step in the right direction. That is what demountable building is about. (Concrete solutions 2013)

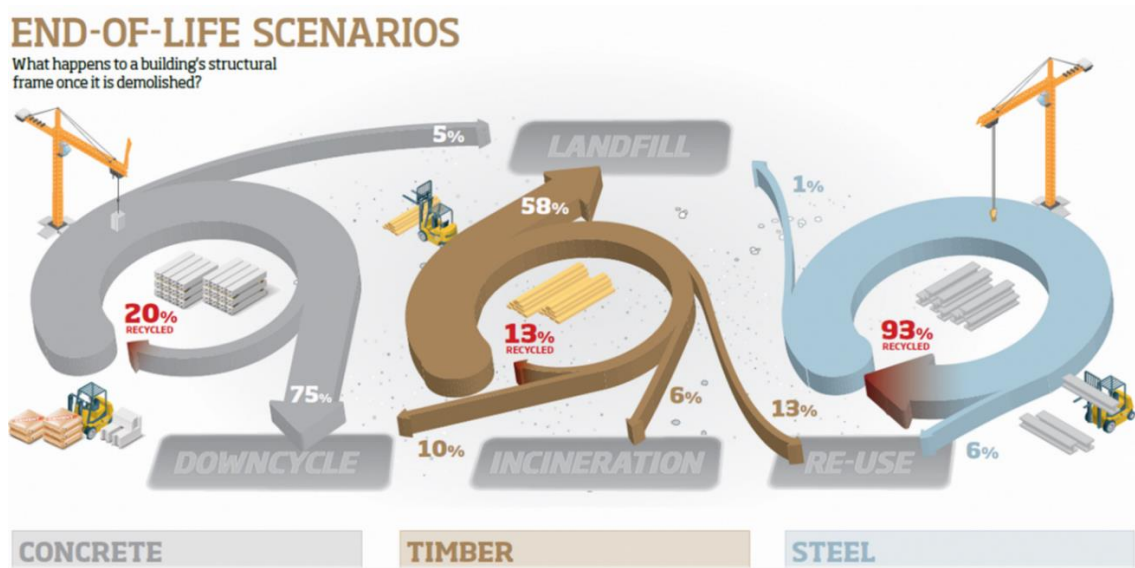

PICTURE 2. End-of-life scenarios (Steel construction 2001)

The end-of-life scenarios that are common nowadays, are shown in PICTURE 2. There is a significant difference between the three main construction materials, being concrete, timber and steel. The recycling rates are rather low, except for steel. The reuse rates were even lower, and for concrete they appeared to be non-existent. As said before, the construction industry is a fast evolving given and since this graph dates back from 2001, the percentages will have changed already. Less material goes to landfill and more efforts are made to recycle and reuse materials. However, this picture indicates that reusing and recycling are not the most popular procedure yet.

4.2.2 Flexibility

Flexible housing can be defined as housing that is capable of adapting to the changing needs of users. During their lifetime, the needs and preferences of human beings change several times. People in their twenties do not need as much space to live as people in their late thirties or forties. A small living room, a bedroom and a bathroom could be sufficient. Once a couple starts a relationship and starts to live together, more space becomes a necessity. That amount of necessary space only grows when they start having kids. Once the kids go off to college or move out, all the space they used becomes unneeded. This trend is visible in living patterns: young people tend to move to the city,

move to the countryside in their thirties, sell their house when their kids move out and relocate to service flats or retirement homes.

This is however not the only reason why flexible housing can be vouched for. In flexible buildings, the users take control of their own living space. Demographically speaking, housing providers are able to adjust to new living patterns. Economically, flexible housing will prevent costs of refurbishment or reconfiguration. Technically, it will enable the user to implement new technology in the building, even long after final completion. Houses would turn into an adaptable given, while they are nowadays often static, unchangeable things. This way of thinking should be used not only for housing buildings, but also for other facilities, such as office buildings, hospitals, public service buildings,... In present day office buildings, it is very often possible to adapt the working spaces, to add or remove offices or reorganise the inner structure of the building. This is mostly due to a clear division between the bearing structure and the finish of the building. The bearing structure functions as a static skeleton that remains the same over time. Within the boundaries that are set by this bearing structure, the user is also allowed to divide the building as he wants. Flexibility is one of the main challenges for buildings nowadays. (Flexible housing 2004).

The crucial factor for flexible building is the design. The initial design of the building enables or disables the building to be adaptable in the future. Demountable building and flexible building goes hand in hand, since making a building demountable improves the flexibility in a certain way. The face of the building can change over time. It must be mentioned that the changes that can be made to a building if it is demountable, still can be quite big. They might affect the use of the building over a certain time, depending on what the changings to the building actually are. For example, if a wall is taken out and replaced by a window, the building will not be out of use. If a series of beams and columns is taken out, the size of the work is bigger and the functionality of the building will temporarily be affected by it.

4.2.3 Energy regulations

New buildings are designed with attention for the energy level and the inner climate. This is mostly due to new energy regulations implemented by the government. Energy resources are precious and should not be wasted.. Belgian energy regulations have been around for a long time, but they have grown more and more strict over the last years. Certain criteria need to be met, and one of the factors that have an influence, is the amount of insulation in walls. In 2009, the regulations required 7 cm of wall insulation. In 2014, this had already increased up to 14 cm, which is a significant difference. This means that a building from 10 years ago is actually already growing outdated, while it is still a very young building. For the classical building method, where a wall consists of an inner wall, a layer of insulation, an air cavity and an outer wall, it is practically impossible to replace the insulation without irreparably damaging the building. If there is a clear division between the structure and the exterior cladding of the building, the walls can be taken out, insulation can be installed and the walls can be put back in place again. This correlates with the problem of flexibility that is described earlier. (EPB)

Homeowners who live in an older house face higher energy bills, due to too little or the lack of insulation in their roofs and walls. To cope with the present-day energy regulation and in order to avoid extra taxes, this needs to be taken care of. Insulating the roof is rather easy, since there is often easy access to the underside of it. Insulating facades and walls is harder. Most of the time, the insulation is fixed in between the inner and the outer wall. It is harder to reach, left aside to replace this insulation without damaging the building. To install new insulation, the outer wall should be demolished and replaced afterwards. However, since the insulation layer will have gotten a lot thicker and an air cavity is a necessity, this could give a problem with the property boundary. Since the inner wall is a part of the bearing construction, it cannot be moved. The extra insulation will take up space outwards of the building. If the building is built right up to the property boundary, the risk exists to exceed this boundary. Other solutions should then be found, like installing a thinner, fake brick wall or a plastic façade. This changes the look of the building drastically, which is something that is not desirable most of the time.

5 PREFABRICATED BUILDING

5.1 What is prefabricated building?

Prefabricated building is a way of building that has been around for quite some time. The capacity of prefabrication has changed a lot over time. In the construction industry, practically everything is prefabricated in a certain way. Bricks, glass windows, wood or metal pieces, cables, plastics: those materials all have been processed before being applied at the construction site. However, when talking about prefabrication nowadays, something completely different is meant: complete elements, ready for use and made in a factory instead of manufacturing them on the construction site. The material will define the capacity of prefabrication. To clarify, steel beams will never be fabricated at the construction site, opposed to concrete. (Precast 2015)

As an example, the manufacturing process of a concrete beam can be analysed. Concrete beams can be casted on the construction site. This involves a lot of steps:

- A scaffolding has to be constructed.
- Concrete specie has to be transported to the construction site. This also influences the layout and structure of the site, since the mixers or pumps need to be able to access the location where the concrete needs to be casted.
- Concrete specie has to be poured and compacted, which requires specific equipment.
- The concrete has to harden for a certain time before the work can continue. This means that the construction time will increase.

By prefabricating that same beam, a lot of these factors are influenced positively. The concrete element has hardened already, no moulds or scaffolding are required on site and a crane to put the beam into place is sufficient as equipment. Another positive consequence is that the construction work does not have to stop and that the quality of execution is higher. (Precast 2015)

Prefabricated building changes the building process from construction on site to assembly on site. Buildings become large construction kits which can quickly be put together.

Working only with prefabricated elements is definitely the first step to a demountable building concept.

5.1.1 Advantages

Using prefabricated construction elements is considered to be the future of the construction industry. The main advantages compared to the classical method are the following:

- Better quality: Bad weather conditions can have a bad influence on the quality of hardening concrete. By producing elements in a factory, they are better protected against that. Also, it is possible to do a quality control and give quality certificates to the components. This leads to higher standards for the elements.
- More precision: The production process can be more precise, which leads to more efficiency of the materials. For example: the concrete cover thickness can be remarkably less, so less steel is necessary for the same result.
- Less waste generation: The materials are dealt with in a more efficient way, since the production processes can be closely followed and optimized in the pre-cast factory. On a traditional construction site, there is always a lot of waste generation, since the probability of variations in quantities of delivered raw materials, inaccurate execution of the work or spilling, will always be present. Replacing the production to a controlled environment will enable a way of “lean construction”, which is not only more efficient, but also cheaper.
- Time savings: Using prefabricated elements saves time, hence costs. The most increasing cost in construction over the last years, has been the wages of the workers. By speeding up the construction process, the execution time decreases, which can save the contractor a lot of money.

The key to success in prefabrication building is to be able to offer the client, the architect and the engineer a solution that is, first of all, buildable. The construction sequence has to be logical and enabling an efficient way of working. It also should be safe, with a continuous guarantee for stability of the works. Secondly, the process should be cost effective. The classical way of building involves costs that are not as high or not present at all in a prefabricated building method, and also the other way round. It should be considered for each project individually what way of building is the most favourable. Finally, the solution should also be fast to erect. Precast manufacturing will obviously take some time, but once started, the construction itself will proceed rapidly. Due to the fact that there is no time necessary for concrete to harden, every step in the building process

will follow shortly the one after the other, which results in less disturbance for the environment around the construction site.

5.1.2 Challenges

Opposed to the positive side, there are some important remarks that can be made:

- The design phase and the coordination at the construction site will ask extra attention and effort. Every element should be delivered just in time. When they are too early, they need to be stored on the construction site, when they are late, the construction process is interrupted generating extra costs. The logistic planning will be more extensive and the organisation has to be exquisite.
- Qualified workers: The work is physically less hard, but the workers should be skilled in installing the prefabricated elements.
- Although the concept of precast building should result in no cast-in-place concrete on site, this is not always the case. In order to secure the stiffness of the joints between the different elements, there is still in situ concrete pouring. To obtain a demountable structure, this way of working has to disappear. Only by using a 100% dry method of constructing, the elements can be taken out again without damaging them.

5.2 Mixed construction

Only using precast is very often not possible for designers, due to economical and practical circumstances. Some materials have limitations that would require an expensive solution if only those materials could be used. As a result, there is a switch to the so called “mixed solution”, where aside from precast concrete elements also steel elements and in situ poured concrete are used. For example long spans are realized with concrete beams, while the columns consist of steel girders or square hollow sections. In 2002, over 50% of the new multi-storey buildings in the western world were built using mixed construction. (Precast concrete structures 2002)

5.3 Types of precast concrete structures

The form and function of a building will determine what type of structure is the best fit. If a lot of functional space which can be adapted to the need of the user of the building

is necessary, the option that will be applied most likely is often referred to as the skeletal structure, since it resembles a skeleton of relatively small but strong components of columns, beams, floors, staircases and sometimes structural walls. By using the skeletal structure, the user of the building has the freedom to change the interior according to his preferences and needs. For example, interior walls can easily be removed or relocated in order to change the functionality of the building. To finish the building off, the outside coating can be executed in a range of different materials, such as brickwork, sheeting or glass, which has been very popular ever since the introduction of the concept by Walter Gropius with the Bauhaus building in Dessau in the early 20th century. Modern office buildings or skyscrapers are almost exclusively designed like this.

A second type of structure is the wall frame structure. Part of the beams and columns are replaced by solid precast bearing walls which support one way bearing floor slabs. The walls are fixed in place, which limits the architectural freedom of the building, but it is often easier and faster, thus cheaper to construct this way. It is important that the final use of the building is kept in mind while designing a building with this type of structure. This technique is suitable for hotels, schools, offices and domestic housing buildings, mostly because these kinds of buildings will serve for one purpose only.

As a third category of prefabricated building, there is the portal frame. The portal is mostly used for industrial buildings and warehouses. The spans of the portal frames go from 25 to 40 metre, using prestressed I or T sections. This type of structure will generate spaces with a lot of functionality. The freedom of how to use the space lies with the user. (Precast concrete structures, 2002)

Looking at these three types of precast from the demountable building angle, the skeletal structure is probably the most interesting one, because it consists of relatively light elements that are easier to demount than the solid walls from the wall frame type or the large girders from the portal frame type. The demountable building concept that is suggested later on in the thesis will be based on the skeletal structure type.

5.4 Joints and connections

Connections form one of the most vital parts of precast concrete design and construction. They determine the type of frame that is used, the limitations of this frame and the progress of the erection process. In order to get a clear understanding of the terms “joints” and “connections”, it is necessary to define them, since they represent similar but slightly different things.

Connection: The total construction between two (or more) connected components, including a part of the precast component itself and possibly several joints. A connection can include e.g. a compression joint, a shear joint and a tension joint.

Joint: The part of a connection at individual boundaries between two elements, for example precast components, in situ concrete, mortar bedding, ...

Connections are required to transfer all types of forces, such as compression, shear, tension, bending or torsion, from one structure to another. It is necessary to have a good understanding about the force paths through the connection, in order to create a good connection design with adequate joints included. Not only the forces that will act on the structure after completion have to be kept in mind, but also the ones that follow during construction, which might be different. Their second primal purpose is to provide stability and robustness to the structure. There is a big variety of joints and connections used, mostly depending on the design of the structure and the specific conditions.

In prefabricated building, there are several different ways to realize the connections, such as bolting, welding or grouting. Depending on the circumstances, one of those methods is chosen. Some of the connections will be considered rigid, while others will be considered as pinned. The difference between those is the way how the structure will sway when forces act on it. Nowadays most of the connections still include in situ poured concrete, since this finalizes the connection and will give extra strength to it. This means that the dry method is not used and that the joints will be harder (or even

impossible) to disassemble without damaging the structural elements. (Connections between precast concrete elements 1985)

5.5 Modular building

Modular construction can be described as the process in which a building is produced off-site and in modules, which are later put together on site. That way, the building is constructed under controlled plant conditions, with the same materials and according to the same standards and codes as conventionally built facilities. This is achieved without compromising the quality and design of the building. On top of that only about half the time is needed to complete construction, compared to the conventional way of building, since a lot of work is done on beforehand. The time to assemble everything on the construction site is shorter than when the classical way of building is applied, and this also results in less disturbance for the near environment of the site. Modules can be seen as 3D prefabricated elements, which have a lot of functionality when they come out of the factory. It is a further evolution from the common way of prefabricated building. (Modular Building 2015)

The Belgian company “Skilpod” produces modules that can function as housing units, external offices or just extra living spaces. Their modules can easily be installed and taken away again. For more information on Skilpod, I refer to appendix 1, which contains the report of a company visit.

6 DEMOUNTABLE BUILDING

6.1 The idea

The idea of demountable building is quite simple: constructing buildings and structures that can be taken apart again. The concept is not new. Ever since the start of the 20th century, there has been a lot of talking and thinking about demountable building. This was mostly caused by the growing need for facilities, especially after the second world war. However, a breakthrough has not happened yet. The reason for this is that the practical side of the story is much more difficult and involves many challenges. Demountable building can easily be compared to construction toys like Lego or K'NEX. Those toys have a lot of standardised elements that can be put together to create structures and can also be taken apart again. The elements then can be reused for new structures. Imagine that only one object can be built with a set of Lego or K'NEX and that for each other object a new set has to be bought. This would generate waste, would be expensive and nobody would buy these kind of toys anymore. However, this is not how it is. Lego and K'NEX can easily be (re-)used in all kind of structures of any shape and size.

When comparing these hypothetical, non-reusable toys with the present way of building, it is not hard to see some resemblance. With one set of materials, only one construction can be built, and for each new structure, a new set of materials has to be purchased. Getting rid of the old construction generates waste and the whole process is expensive. The fact that buildings are essential for humans to live in, avoids reflecting about the choice of whether or not to build. This is probably why the classic way of building has not changed much, but it is worth to pose the question whether the present way of building is the best. Given the expanding environmental problems for which the construction industry is co-responsible, the answer is probably no. By copying the successful recipe of Lego and K'NEX, the solution is there to grab: making it possible to take buildings apart again and reusing the components. By following this way of thinking, the classic way of building should be transformed into an assembling process of prefabricated elements.

6.2 SWOT-analysis

A SWOT-analysis is a tool that is often used for situational analysis. It is suitable for both personal life as businesses. SWOT is an acronym for strengths, weaknesses, opportunities and threats. The former two represent the internal advantages and disadvantages that can be controlled. The latter two discuss uncontrollable external factors that affect the situation. It is useful to conduct a SWOT-analysis on demountable building concepts in order to get a better understanding of the advantages and disadvantages as well as the challenges and the benefits.

TABLE 1. SWOT-analysis demountable building concepts

Strengths	Weaknesses
<ul style="list-style-type: none"> • Possibilities to <u>adapt</u> buildings to changing needs of the habitant, without relocating them to a different location or building a new dwelling. • <u>Ecological impact</u>. By reusing building elements, there is a saving in new raw materials, hence additional costs. • Possibility to <u>renew</u> parts of the building without having to demolish it completely. If a piece of the building does not suffice anymore, due to damage or wear, it can be replaced. 	<ul style="list-style-type: none"> • <u>Little knowledge</u>. A lot of research has to be done before the concept is workable. • <u>Additional costs</u> to recover elements, store them, trade them, ... • <u>Quality assurance issues</u>. The “behaviour” of a demountable building is unknown.
Opportunities	Threats
<ul style="list-style-type: none"> • Need for <u>sustainable solutions</u> • Changing view on how to deal with material. There is a <u>growing awareness</u> that recycling and reusing are important. 	<ul style="list-style-type: none"> • <u>Underdevelopment of the market</u>. There is no sufficient way to buy and sell construction components. • <u>Distrust in the concept</u>. There might be scepticism towards the idea.

6.3 Urban mining

6.3.1 Definition

Urban mining can be defined as the process of reclaiming compounds and elements from products, buildings and waste. This is a definition of what urban mining means, but in fact it is about changing our view on materials. The classic view on materials nowadays is that they turn into waste after their primary use is no longer necessary. This cradle-to-grave mentality is outdated and the believe in cradle-to-cradle cycles has been increasing over the last decades. The cities that have been built over the years are full of resources. Instead of seeing the applied materials as waste, they can also be seen as possible resources. From buildings to public infrastructure, from the structure to the applied electronics, every single thing has possibilities to reuse or recycle. Urban mining can be divided into different categories that have to do with the scale of the “mining process”. (Urban Mining 2014)

The obvious example is recycling old electronics, which is also the origin of urban mining as a concept. It is common knowledge that a computer's motherboard contains gold and other valuable metals. These materials can be used for new electronics. This e-waste recycling was the origin of urban mining. There is a possibility to expand this from old electronics to waste of buildings to so much more. Huge junkyards filled with old metals are a fresh mine for recyclers. Another example is the automotive industry. Cars contain a lot of resources that can be reused after the lifetime of the car is over. This is a definitely a profitable solution. In China, there were 7.2 million passenger cars sold in 2009. If only 20% are to be recovered, the projected economic loss is about 200 billion Chinese Yuan, which corresponds with approximately 29 billion euro. This estimation is based on the metallic market price in China. FIGURE 3 shows the material composition of a passenger car and the percentages that these materials represent in the car. The biggest share of material goes to iron and aluminium. (Urban Mining in Automobile Recycling 2011)

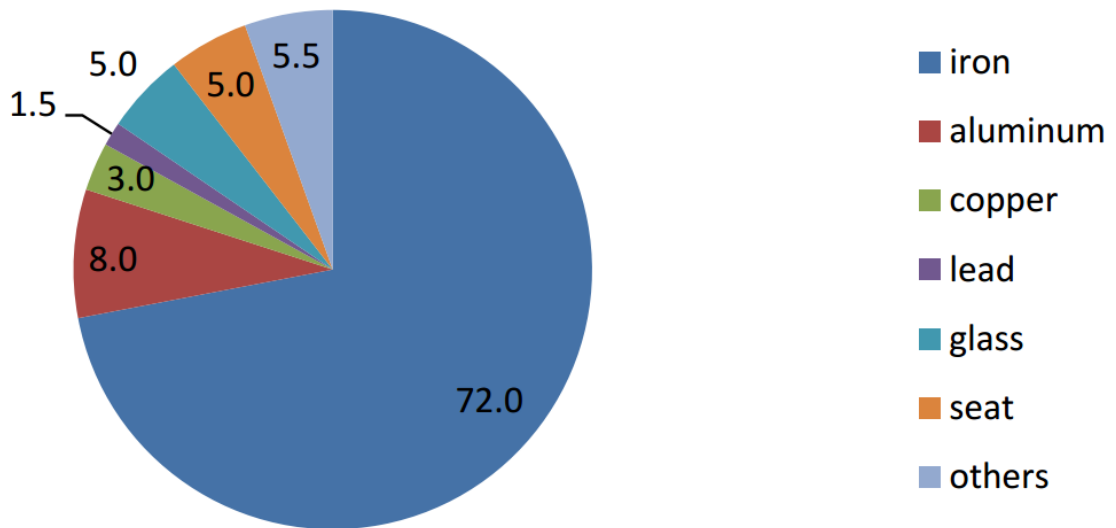

FIGURE 3. Material composition of a passenger car (Urban Mining in Automobile Recycling 2011)

6.3.2 History

The concept of urban mining originated in the 1980's. Japan was already a heavy user of electronics, so also of precious and rare metals. However, the country largely depended on China for the import of these resources. Professor Nanjyo of Tohoku University of Japan was the person to first use the term of urban mining. He wanted to promote recycling and reuse of these metals. For him, it was primarily focused on this e-waste. Professor Nanjyo may have named the idea. However, he was not the first, nor the only one to change his way of thinking. Journalist, writer, activist and urbanist Jane Jacobs quotes in 1961: "cities are the mines of the future". She made some remarkable observations and predictions, quite ahead of her time. She said that hard-rock mining is energy intensive and environmentally problematic; the extraction of metals out of rock is always increasing, while the quantity of these metals is not; most of these metals end up in cities and last: these 'urban ores' may provide an alternative to virgin metals. As these were just the early principles of urban mining, her ideas turn out to be very important. In July 2010, China announced a reduction of this export by 72% due to its own growing population and need for these materials. This was not only a problem for Japan, but for the whole world. Several companies started to stock-pile these precious minerals, others turned to other supplier countries such as Vietnam. Some groups however, invested in

new technology and changed their way of thinking. Combined with the already very big concern for the environment, urban mining became a worldwide concept of innovation and progress. (Urban Mining in Automobile Recycling 2011)

6.3.3 SWOT-analysis

Urban Mining as a concept can be analysed with SWOT. This gives a clearer overview and a better understanding.

TABLE 2. SWOT-analysis urban mining (The potential of urban mining 2013)

Strengths	Weaknesses
<ul style="list-style-type: none"> • <u>Recycling saves new raw materials. Material cycles are closed.</u> This will turn out to be profitable in the long haul. • <u>Reduces rubbish.</u> By using materials that are now seen as waste, there will be less disposal. This saves space and creates a healthier environment. • <u>More efficient</u> mining processes, since the material has been processed at least once before. 	<ul style="list-style-type: none"> • <u>Materials can be contaminated.</u> The initial origin of the material is hard to trace, so the material might contain contaminations or hazardous substances. • <u>Mentality of consumerism.</u> Urban mining does not stroke with the general current mentality.
Opportunities	Threats
<ul style="list-style-type: none"> • <u>Growing demand for resources,</u> while the supply stays equal. • Global need for <u>sustainable solutions</u> • Changing view on how to deal with material. There is a <u>growing awareness</u> that recycling and reusing are important. 	<ul style="list-style-type: none"> • <u>Underdevelopment of the market.</u> There is a need for proper facilities. • <u>Distrust in the concept.</u> There might be scepticism towards the idea. • <u>Financial.</u> Example: it is ten times cheaper for the United States to ship e-waste to Asia than it is to process it domestically.

6.3.4 Different categories

A problem with urban mining or recycling in general is that lots of materials never reach the correct recycling plant so a lot of it still gets to be thrown away. Therefore, four different categories are suggested to separate different kinds of waste. With each of these categories comes a different way of thinking and a different way to apply urban mining.

E-waste

E-waste consists of discarded devices such as cell phones, computers, radios, etc... E-waste devices contain valuable metals such as gold, silver, copper and palladium. Taking out these metals was the first perception of what the term urban mining meant. This type of waste has become one of the fastest growing waste streams in the world. According to the Australian Bureau of Statistics (ABS), up to 2008, 17 million televisions and 37 million computers have been sent to landfill. If 75% of the 1,5 million televisions that are discarded each year could be recycled, the consequences would be remarkable: a saving 23000 tons of greenhouse gas emissions, 520 mega liters of water, 400000 gigajoules of energy and 160000 cubic meters of landfill space. The advantages become even more clear with the comparison of mining gold from an open mine pit and from electrical goods. The first way of mining provides 1 to 5 grams of gold out of one ton of ore. By mining gold from a ton of discarded mobile phones and computer circuit boards, respectively 350 grams and 250 grams of gold can be won. (A. Littleboy, 2014)

Non-structural building elements

There are a lot of fixed facilities in buildings that can be taken out before the building is demolished. Electrical copper wiring, PVC pipes, glass windows, washbasins, lamps, doors: stripping these elements out of the building can transform them from a waste product into new resources, which can even return money. As an example, think of the amounts of copper that can be reclaimed from all the electrical facilities. The same logic goes for other parts of the building. By demolishing it selectively, the building can be

stripped from all valuables. The perfect scenario is to be left with nothing but the bearing structure after the building has been stripped, but in reality it is always more complicated than that. However, this should be the goal that is pursued.

Structural building elements

The principle of being demountable means that building elements and the elementary structure can be “mined” from buildings. The amount of steel, concrete, wood or aluminium that is used in buildings is vast. The production of all these materials once required a lot of energy and materials. Professor Thomas E. Graedel from the Yale School of Forestry and Environmental Science believes that, once aluminium is extracted from these buildings when they have reached the end of their life-cycle, the aluminium can be reused. The process to recycle the aluminium will only cost about 5% of their original production process. Certainly in big cities, aluminium is an urban ore in an urban mine. The same goes for steel. These two materials are easy to recover. Concrete is, at least for now, another matter. It is very hard to reuse concrete elements from a building, since they are always fixed into the structure of the building and taking them out without doing serious damage is almost impossible. (The bridge linking engineering and society 2011)

Byproducts

Urban mining is more than just recycling and reusing, and it is also more than just about raw materials. The laws of thermodynamics teaches us that the production of heat is inevitable with all human activities, natural systems and all organisms. Recycling heat is something that can save money but requires new technologies and advanced techniques. A power plant produces heat, steam or hot water. Those heated sources can be seen as raw material in an urban mine. They can be used to heat up other facilities and reduce the need for fossil fuels. Sludge from production or coming from dredging activities, is often seen as a waste product. It can, under certain conditions, be used in the production of red brick or in concrete. The fly ashes from incinerators can, depending on their

composition and quality, be used to produce cement. A power plant may be very polluting, but it can also be seen as a mine. (Technology Forecasters 2010)

In the Danish city Kalundborg, there is an initiative called the “Kalundborg Symbiosis”. A couple of companies put their heads together and started to use each other’s waste products as raw materials. By cooperating, they closed the material cycle and this has been gaining them a lot of money ever since. This proves that closed material cycles can be profitable and that it is really possible to do it. By looking at the cities as the mines of the future, a big step in the right direction can be made.

It is obvious that the third category (structural building elements) is the most relevant one for this thesis. Taking the idea of urban mining into the construction industry is an initial step to a workable demountable building concept.

6.3.5 RAU

Urban mining is a very wide term. In every branch where it can be applied, it shows differences. To clarify what it means for the construction world, it might be useful to explore the train of thought of Thomas Rau. Thomas Rau is a Dutch architect with visionary ideas on sustainability in architecture and economy in general. His architectural team RAU designs buildings with the underlying thought of making a positive contribution to society and planet earth. The way that economy is existing nowadays is unsustainable, and in the eyes of Rau, there are two options. The first one is not changing anything, which will eventually result in unfavourable circumstances. The other option is redefining our economy in the future. It obviously cannot disappear, but it needs new game rules. According to Rau, these are a couple of those new game rules:

- Being responsible for the consequences of one’s own actions. Society is built around the principle that the responsibility for actions do not stay with the person that initially performed them. A producer makes a product, for which the responsibility after sale is transferred to the customer. As an example: when customers purchase a house which is not performing sufficiently regarding energy regulations, they are responsible for the consequences and will have to bear the costs to fix it.

- Using instead of consuming: Consuming should happen “performance based” instead of “property based”. This means that it is about using instead of consuming. Rau gives a clear example. A couple of years ago, he made the agreement with the Dutch company Philips that they would provide him with light. Philips is a well-known manufacturer of lamps, but Rau was not interested in their lamps. He only wanted the light. The lamps stayed the property of Philips, and if they broke down easily, the costs were not for Rau, but for them. By making high quality products, Philips only benefited from this agreement.
- Raw materials cannot be traded anymore. They only should be considered as borrowed. By seeing them as a tradable good, we use them as if they are infinite, which they are not.
- Everything that is arguably harmful to society should be taxed. When someone taps value from society, he should pay for that. Instead of a tax on added value, as there is now, there should be a tax on tapped value.
- Do not tax labour. There is an enormous amount of energy and potential labour on earth, coming from the people. After a night of sleep, people are able to work and contribute to society. This energy can be seen as infinite, and this should not be taxed.

The city of the future is for Rau a city in which property does not exist anymore. People do not have a car, but have access to mobility instead. They are free to choose how they do that. The same goes for buildings: people do not own a building anymore, but define a space for themselves that they want to use. This forces to think in a short cycled way about buildings, that exist for a short time span. That way, the buildings can adapt more easily to the changing needs and preferences of the users. Products, and this includes buildings, should be seen as depots for raw materials. After their lifetime, the raw materials become available again and can be reused.

There is enough energy and labour available on this planet, but the amount of raw materials is bounded. This is the main thought that should be kept in mind when thinking about the evolution that is necessary. Demountable building corresponds with this way of thinking. The resources that are used to manufacture elements will not be demolished or disposed of afterwards, but reused instead. The vision of Rau can serve as a guide for the train of thought of why demountable building could be a viable concept. (Duurzaam nieuws 2014)

6.4 Existing systems

Since there has been a lot of talking and thinking about demountable building, it is obvious that there are also some developed ideas and systems. This goes from patents to actual constructions that have been realised. Some of the patents are described below and can be found in the appendices. Next to that, also an interesting system called PRESSS is discussed. At last there are also some practical examples of demountable building structures.

6.4.1 Patents

Over the course of the 20th century, designers, architects and engineers have been developing concepts for buildings. Patents are a good rendition of the ideas of inventors over time. In the appendices, some of these patents are added. The problem with them is that they are often just theoretical concepts that are not suitable for common use, probably due to some difficulties regarding execution.

In Appendix 2, a system to join precast concrete columns and slabs is described. The patent was filed in 1998.

In Appendix 3, a demountable building partition system is described. This patent was filed in 1968 and refers to modern office buildings, since it is very often necessary in those kinds of buildings to rearrange the inner division of the space. It proves that the awareness of the need for flexibility was already present during that time. This kind of partitions and variations on it are commonly used nowadays.

6.4.2 PRESSS

Seismic activity is very common all over the globe, in one location significantly more than the other, due to the tectonic plate movements. In regions with a lot of seismic activity, buildings require a different design than in regions without. In general, it has been a struggle to find a building concept that is suitable and behaves properly in these circumstances. In the late 1990's, a new building concept was developed in the United States: PRESSS, which is an abbreviation for Precast Seismic Structural System. The

primal purpose was to be able to apply precast concrete in seismic regions. In New Zealand, Mainzeal Property and Construction Ltd. developed and tested the system by constructing a real building with it. The realised building is the Alan MacDiarmid building, located at the Victoria University campus in Wellington, New Zealand. In 2010, the building won the prestigious Sustainability Award. Although the building is constructed using this special method, it looks like any other building on the outside, as is visible on PICTURE 3.



PICTURE 3. Alan MacDiarmid Building (NZIA)

Although the outside looks pretty normal, on the inside there are some things that give away the true nature of the building. Especially the joints do not look conventional. On PICTURE 4, a detail of the way the foundation is connected to a column is shown. Steel tubes go through holes in the bottom of the column, which are connected with a bolted system to the foundation. It is easy to see that this joint is suitable to disassemble. Since the joint is on the outside, it takes up some more space than usual. In order to prevent a big loss in space and a discomfort by that, the bottom of the column is narrowed. PICTURE 5 shows a connection between columns and beams. The same system as with the

foundation is used here. The joint piece is definitely not complicated, but here it is inevitable to use more space than with the conventional method. Although the heads of the beams are narrowed, the same way as with the columns, the joint requires an extra steel support underneath the head of the beam. This is because the shear forces on the bolt system would be way too big to take. The bolt system is designed to be easily replaceable in case of damage or breaking.



PICTURE 4. Detail of foundation



PICTURE 5. Detail of connection

The main aim for this system was to make an earthquake resistant structure. That is why the joints and the other elements are clearly separated: they can move aside from each other and do not depend on each other. If an element or joint gets damaged or broken, it can quite easily be replaced. This system can be a big inspiration for developers of demountable building concepts. (ccanz.org.nz)

6.5 Examples

6.5.1 Parking garage

In the Belgian city of Ghent, the entire neighbourhood of the railway station is currently being renovated. The work will take more than ten years to complete. Since the facilities near the railway station still need to be present, even though they are being demolished and rebuilt, new solutions had to be found. The continuous need for parking space for cars is one of those problems. Building a new parking garage to demolish it after the end of the works was one of the options, but would not be interesting economically nor environmentally. The fitting solution was to build a parking garage that was easily to erect and can be demounted afterwards. That way, it can be used somewhere else and have a second lifetime. There is room for approximately seven hundred cars. The main structure is manufactured in steel, while the floor slabs are concrete. In the floor slabs, there are tubes poured in, in order to take care of the connection between the steel structure and the slabs. The actual connection is realised with a dowel. The poured in tubes and the dowels result in a limited tolerance for the floor slabs. Working with precision is a must.

The requirement of being demountable has imposed some provisions to make in the design phase. The floor slabs are finished off really smoothly, because they need to be covered with an asphalt layer of four centimetres, that has to be easy to scrape off afterwards. There are also sunken lifting anchors poured in, which are filled up with custom made polystyrene filling elements. This makes it easy to free the lifting anchors in the demounting phase.

On PICTURE 6, a detail of the build-up of the parking garage is shown. The steel beams and columns are joint together with bolts. This makes it easy to disassemble. In the upper surface of the steel beams, there are pins sticking out every 1,20m. The floor slabs fit perfectly on those, so the whole can be fixed together. Also the lifting anchors are clearly visible on the detail. PICTURE 7 shows an overview of one of the stories of the parking garage. The finishing works still need to be done, since the lifting anchors

are still visible, at the right side of the picture. Despite of the fact that the structure is demountable, it does not look any different than a conventionally built structure. Of course a parking garage has other standards and requirements than a housing or office building, but this example shows that there are a lot of options to explore. The bearing structure holds up perfectly and creates functional space. With a different kind of finish, there are various possibilities of what this building can serve for. (IFD Bouwen 2014)



PICTURE 6. Detail of parking garage (IFD Bouwen 2014)



PICTURE 7. Overview of parking garage (IFD Bouwen 2014)

Parking garages are nowadays often built to be demountable. The American company “More Park” has been offering a solution for the problem of parking space. The More Park system is completely demountable, built in modules which are bolted together and with a precast deck that is bolted to the steel structure. After its lifetime, it can be dismantled with hand tools and a fork lift. It can be re-erected on another location or recycled. The More Park system also does not require foundations, which results in a fast construction and no disturbance on the site after removal of the car park. (More Park 2014)

6.5.2 Extensible company building

The Belgian company Barco NV started building its new headquarters in 2002. Later on, the building might have to be extended with a new part or rearranged on the inside. In order to be flexible and make future changes possible, some provisions had to be made. Parts of the building with a very differing use cycles are disconnected from each

other. The bearing structure and the technical equipment of the building are completely separated, as well as the inner partitions. A part of one of the facades is designed and constructed to be demountable and be replaceable by windows. (IFD Bouwen 2014)



PICTURE 8. Company building Barco NV (IFD Bouwen 2014)

In PICTURE 8, there is a zone in the façade that is hatched in orange. This is the part of the wall that can be taken out and replaced by windows later on. The wall consists of self-supporting sandwich panels which rest on steel consoles that are provided in the columns. PICTURE 9 shows details of how the columns are made. On the left, there is an overview of a column. Two consoles are provided, as well as a lifting tube in the top part of the column. The drawing on the right top is an axonometric view of a console for the sandwich panels. The drawing on the right bottom is a frontal view of the console with the correct dimensions.

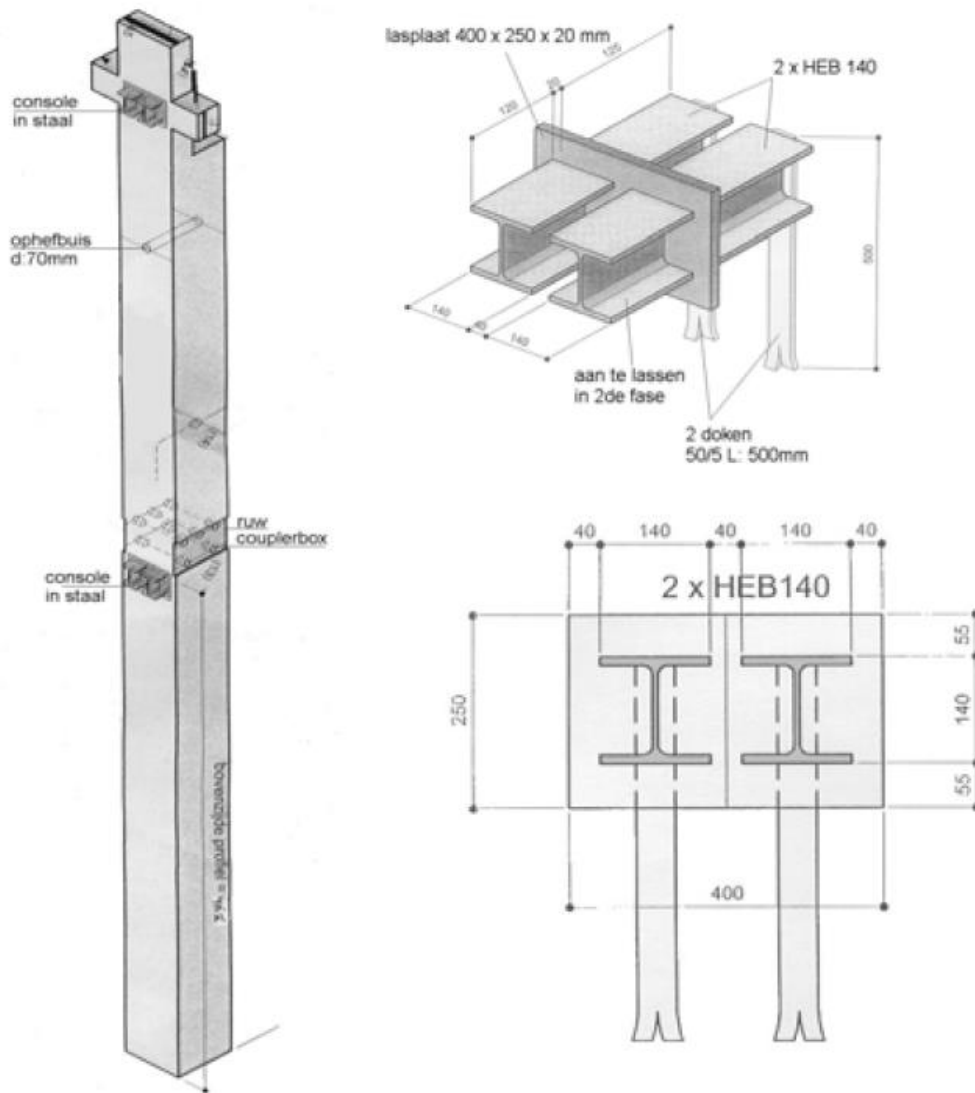

PICTURE 9. Details of company building (IFD Bouwen 2014)

7 A DEMOUNTABLE BUILDING CONCEPT

7.1 General concept

Demountable building with steel is much more evident than with concrete. A structure out of steel columns and beams, joint by bolted connections is the easy way of achieving a demountable building. The concept as described below will start from the perception that concrete is used as the main building material. The building process from nowadays involves prefabricated elements, combined with a lot of construction works on site. In order to obtain a demountable way of construction, the building process has to evolve to an assembly process of prefabricated elements which are delivered at the construction site, ready for use. The applied structure of the buildings is the skeletal structure, with beams and columns out of concrete, which are joint together using steel connection parts. In fact, the building should be seen as a big construction kit. Floor slabs can be fixed to the beams with bolted connections or dowels. The finish of the building has to be well separated from the bearing structure, which gives the architects and designers the freedom to make it look like they want to, as long as it is not compromising the stability of the structure.

Constructing a building that will be completely demountable and therefore generate zero waste is not realistic. Nonetheless, if the materials of the finish are well chosen and if the bearing structure is reusable, it could mean a vast improvement to the environmentally damaging construction industry.

7.2 Joints and connections

One of the biggest disadvantages of current connections lie in the need for labour and the prolonged assembling times, mostly due to the fact that the connections often need to be finished off with in situ poured concrete or grouting. This enforces the need for dry mechanical connections, together with the need for simplifying the stabilization of the structures. These dry mechanical connections will enable the structure to be demounted without damaging the construction components. The mechanical connections can be prepared quickly and without special workers. They are ready to function immediately once the components are joint together, thus they also act as a fixing during erec-

tion, which will decrease the need of extra scaffolding or supporting. Another advantage of the dry mechanical connection is that the displacements due to shrinkage, creep or temperature changes in elements are allowed. One of the developed and innovated connection techniques is the dowel plate. The functional role of the dowel plate is to take the shear force of the connection, while the tensile forces are taken with high strength prestressed bolts. The dowel plate should be stiff and sufficiently strong to take the moments of one part of the structure and transfer them to another part. This kind of connection are suitable for use where a high shear capacity is required. The grade of prestressing of the bolts will determine how much bending capacity the joint will have.

The advantages in production are mainly the possibility of prefabrication, easy mounting on site and the possibility to demount and reuse. The disadvantage is that the demounted elements have been adapted for one particular structure. There might have been holes drilled for the bolts, for example. This implies that the freedom to give the element a new purpose is reduced. With a dowel plate, the demounting will be possible, but the reuse of the component is not assured. (Connections between precast concrete elements, 1985)

Another way to approach demountable building with concrete, is separating the joints completely from the other construction elements. The building components could be made of concrete, while steel is used to manufacture the joints, resembling the PRESSS concept. A lot of various models of joints has to be offered: pieces to join a column and one beam, pieces to join a column and two beams, corner pieces, etc... It is important that the joints do not damage the construction components. A plastic or rubber inline can help to protect the concrete from crumbling and allow some moving space, since there will always be some settling of the structure after final completion and during the first years of use.

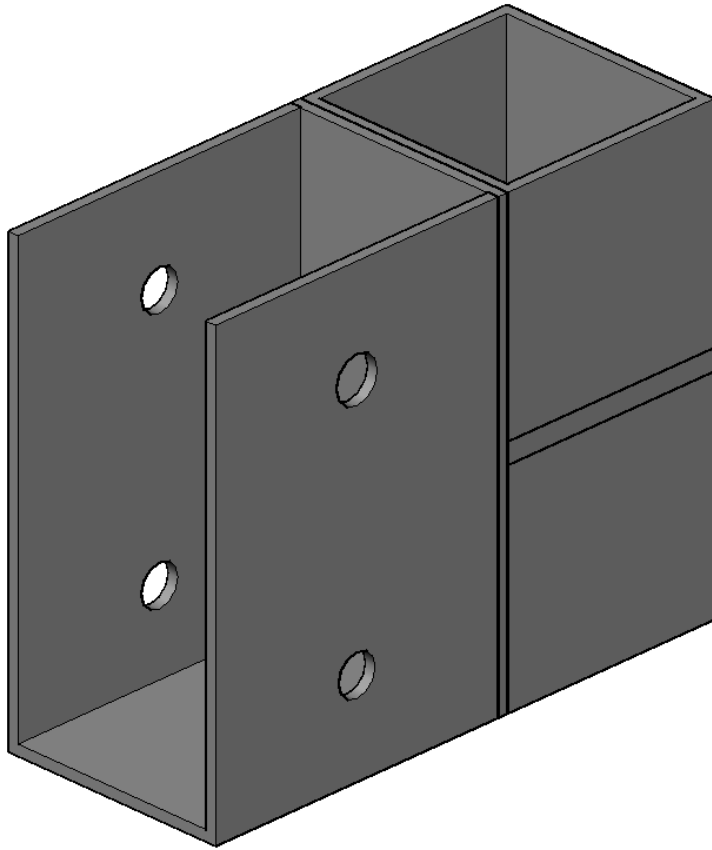

PICTURE 10. Connection piece

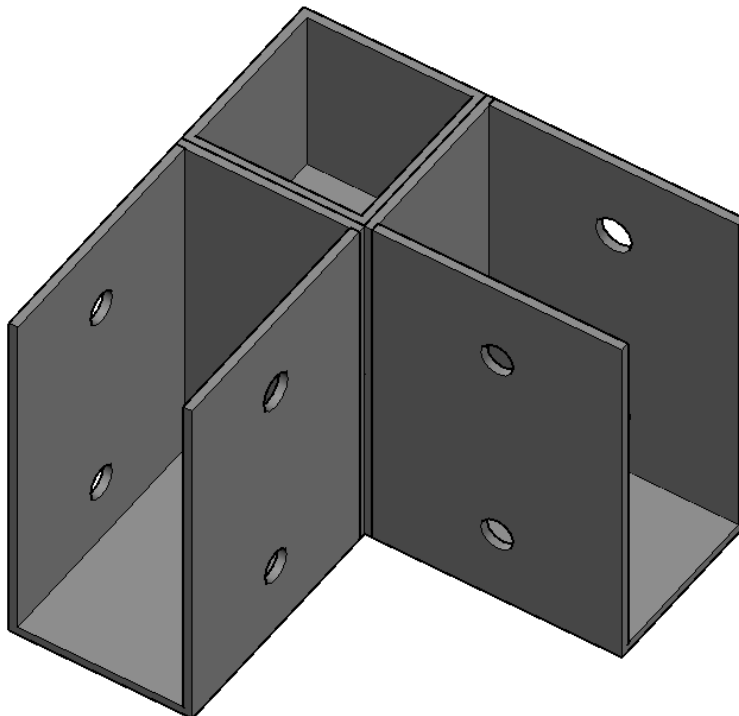

PICTURE 11. Connection piece

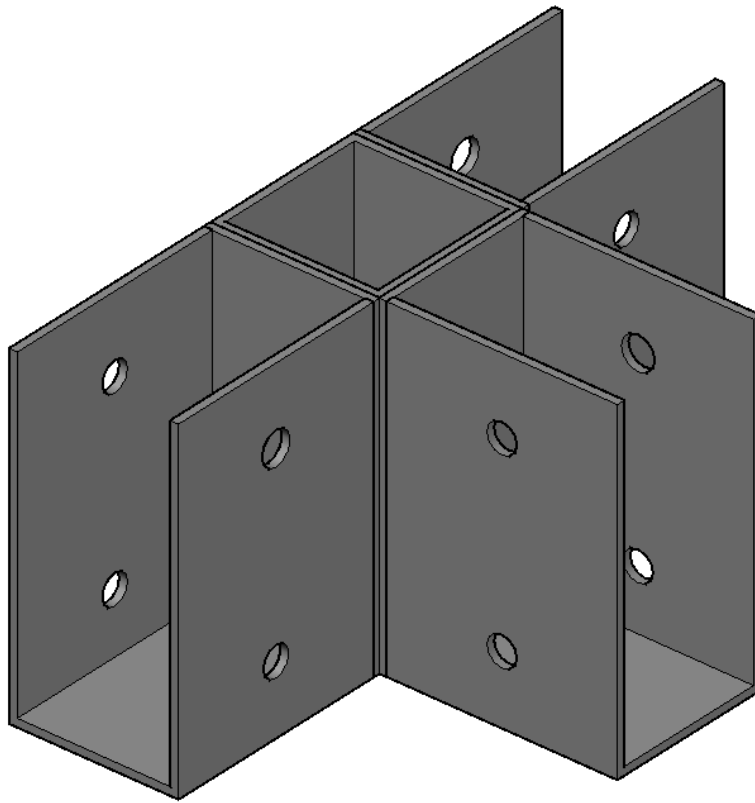

PICTURE 12. Connection piece

PICTURE 10, PICTURE 11 and PICTURE 12 show drawings of a possible, simplified design for the connection pieces. The biggest challenge with this kind of connection pieces is to design them so they are sturdy, but still slim, so they do not take up too much space. The architects and designers need to consider while they are working that there will be extra space necessary for the joints. After all, the transmission of the forces happens outside of the beams and columns, while using the classic method, it happens on the inside.

The shear forces between the beams and the columns will be high, due to the loads on the beam and its own weight. Possibly it will be necessary to use rivets or shear bolts in the connection piece to transfer them. The holes in the side serve to be compatible with the beams and to secure them in their place with a bolt. It is not the aim to transfer the acting moments in the beam, since the structure is calculated as having hinges instead of fixed connections. The advantage of this system is that the construction elements are clearly separated from the joints, which enables the demounting on the one hand, and also the reuse of the components on the other.

Nowadays, there is no market, nor a supply for this kind of joint elements because the demand is non-existent. The pictures and descriptions above are merely hypothetical and should not be taken for granted. However, they can serve as an inspiration for designers. The connection pieces should be developed and tested thoroughly before applying them in real structures.

7.3 Construction elements

The construction elements form a very important item in the whole concept, since they are the components that take up the bigger part of the raw materials. They need to be designed and manufactured with great care for their quality, since they need a long lifetime. This requires an adapted production process and more qualified workers, compared to a standard precast element production. Next to a good quality, the concrete elements need some other properties as well.

For starters, the concrete elements should be standardised: a certain number of different dimensions has to be available, so different spans and heights can be cleared, but it is necessary that there is not too much variation in dimensions. This has a big influence on the design phase of the building: the freedom of the architect is limited and the structure of the building will be a lot more standard than before, which also means that this way of building will not be suitable for all kinds of facilities, but for infrastructure such as offices or housing buildings, it can be a good fit.

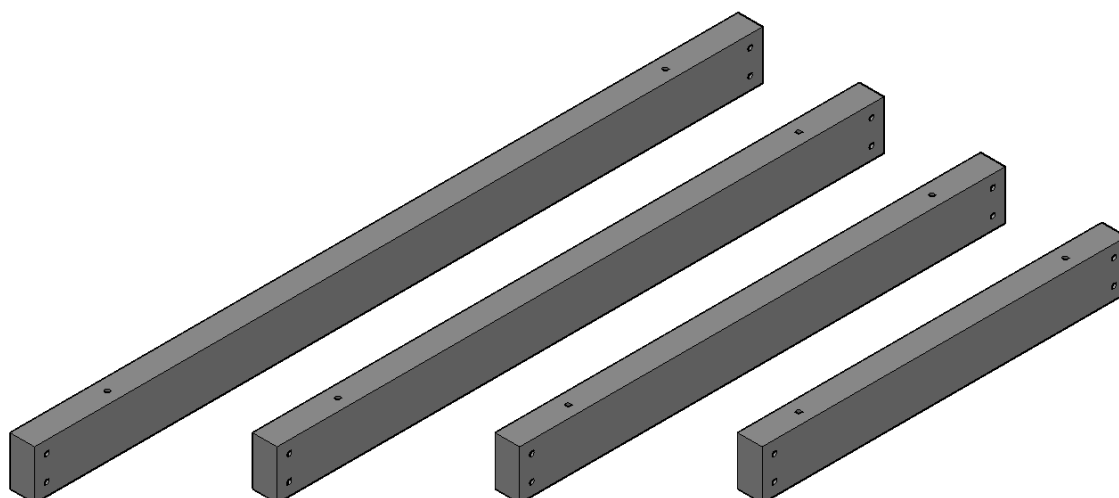

PICTURE 13. Beams

The beams need to be attachable to the connection pieces in a way that they can be de-mounted again afterwards, without damaging the element nor the connection piece. At the head of each beam, two holes are provided, matching with the connection pieces. A steel tube or bolt that is pushed through the holes of both the beam and the connection piece can keep the beam in place. Later on, those bolts or tubes can be used to attach a wind bracing to the structure, in order to ensure the stability in all conditions.

Another property that the beams and columns need to have, is being liftable in a safe way without compromising the strength and the quality of the components. One way to lift them in a controlled way is by providing holes in the beam, through which a lifting cable or tube can be pulled. The holes can go from the top to the bottom of the beam or from one side to the other. If they go from top to bottom, it means an easy way to attach cables or tubes, but also that there is a weak spot in the pressure and tension zone of the beam at this place, although the exact influence is unknown. It might be a better idea to provide the holes in the tension zone of the beam from one side to the other, since the reinforcement bars provide the tension strength in the beams.

On PICTURE 13, a simplified graphical rendition of four different sizes of beams is given, also showing the holes at the heads of the beams, as well as the holes that are provided to make the element liftable. It should be mentioned that this is merely a theoretical example of the design of the beams. This needs to be studied, developed and tested before actual application.

8 TECHNICAL BARRIERS

8.1 Joints and construction elements

In demountable building concepts, the joints are a crucial item. They must be well thought out, because they are slightly different than normal joints. They should be reachable, easy to disassemble and should not deliver the strength and stiffness to the building.

8.1.1 Stiffness of the joints: influence on the calculation method

The joints are made to be demountable. This means that they are not as stiff as joints that are poured in with concrete. This changes the way of calculating the building. If the classical method is used, the moments which act on the beams will be transferred to the columns and the calculations will be hyper static, due to the stiffness of the joints. Hyper static systems are favourable because the total acting moments are smaller than in isostatic systems. However, the joints in a demountable building system probably will not be able to guarantee a hyper static system. Other than that, one part of the structure cannot be dependent on another part, for the simple reason that those other parts possibly can be demounted while another part of the building stays upright.

This has an influence on the calculation method: every part of the building has to be calculated like an isostatic system. As a direct consequence of that, the dimensions of the concrete beams will increase. This means that more material will be necessary to manufacture the elements, which is a negative consequence regarding sustainability.

In order to get an image of what the difference in calculation is between an isostatic and a hyper static system and what the difference in amount of material might be, it is useful to take a look at a worked example. The following is a structure that was calculated both hyper statically as iso statically. After calculation, the results can be compared and conclusions can be made. The calculated structure is basic and could be part of a bigger building. It merely serves to illustrate the difference between the two calculation methods. The calculation software that was used is SCIA Engineer 14.

Data

Material

Concrete C30/37

Dimensions

Columns: 150 mm * 150 mm * 3 m

Beams: 150 mm * 400 mm * 6 m

Loads

The loads on the framework are the following:

- 25 kN/m on the horizontal beams. This is a simplified rendition of the user load. No coefficients were applied since this is just an illustration.
- 15 kN/m on the right columns. This is a simplified rendition of the wind load. Also here, no coefficients were applied.

The supporting points on the left side of the framework represent the effect of a rigid core, like an elevator shaft, in order to make sure the framework does not sway and is calculable.

The applied loads are chosen at random and serve only to demonstrate the difference between the two methods. PICTURE 14 is a 3D rendition of the model, while on PICTURE 15 the applied loads are shown.

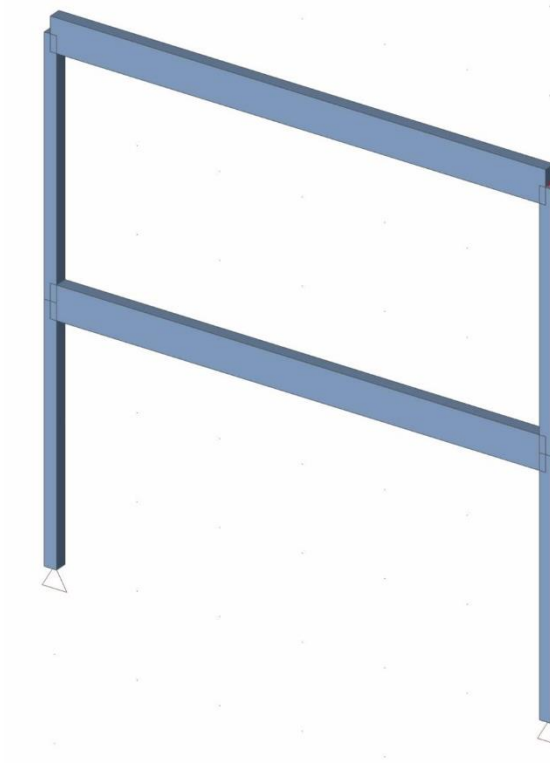

PICTURE 14. 3D rendition of the framework

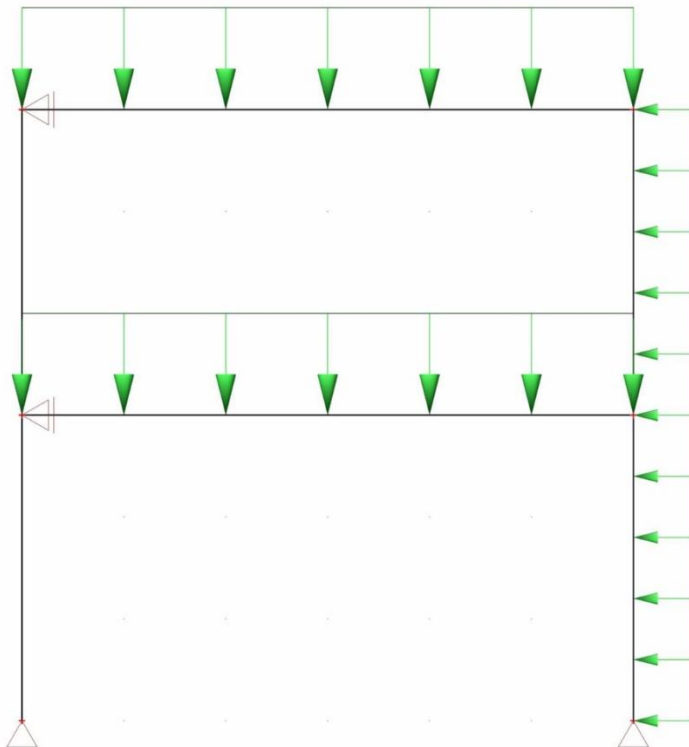

PICTURE 15. Loads on the framework

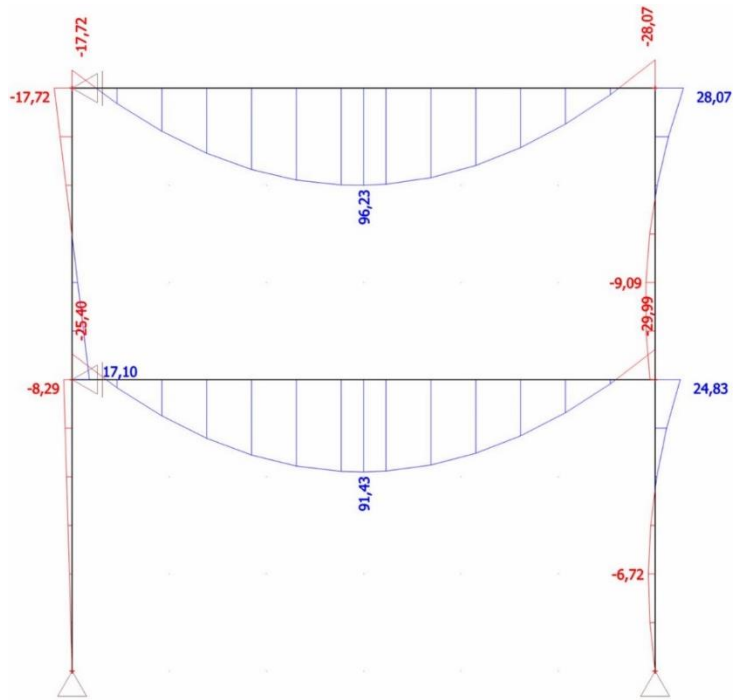

PICTURE 16. Moments hyper static calculation method

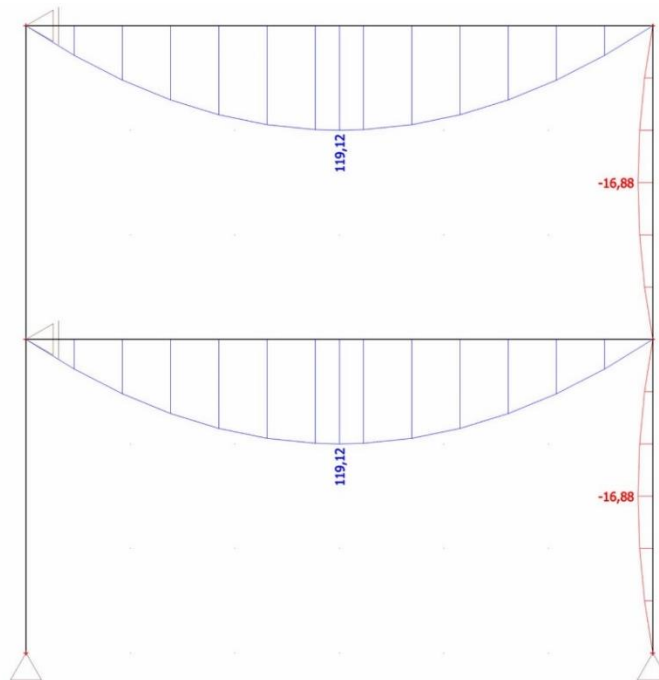

PICTURE 17. Moments iso static calculation method

The difference between the two calculation methods is clear when looking at the acting moments, as visible on PICTURE 16 and PICTURE 17. The maximum moment in the hyper static calculation method is 96,23 kNm in the beams and 28,07 kNm in the col-

umns. In the iso static model, the maximum moment in the beams is 119,12 kNm and 16,88 kNm in the columns, which is a significant difference. This will also result in a different amount of reinforcement steel. In one component, the difference might not seem that big, but on the scale of a complete building, which has a lot of elements, the amount of extra steel will be remarkably higher.

TABLE 3. Reinforcement hyper static calculation method

Design As EN 1992-1-1

Linear calculation, Extreme : Member

Selection : All

Combinations : Combi1

Main upper reinforcement for selected beams

Member	d_x [m]	Case	N_d [kN]	M_{yd} [kNm]	x_u [mm]	d [mm]	$A_{s,req}$ [mm ²]	Reinf.[no.]	W/E
S1	3,000	Combi1/1	-157,99	-8,29	77	97	181	1x20,0(314)	65
S5	6,000	Combi1/1	-42,20	-29,99	58	347	193	1x20,0(314)	65
S6	6,000	Combi1/1	-33,58	-28,07	53	347	187	1x20,0(314)	65

Main lower reinforcement for selected beams

Member	d_x [m]	Case	N_d [kN]	M_{yd} [kNm]	x_u [mm]	d [mm]	$A_{s,req}$ [mm ²]	Reinf.[no.]	W/E
S1	3,000	Combi1/1	-157,99	-8,29	77	97	195	1x20,0(314)	
S2	0,000	Combi1/1	-79,34	17,10	0	0	0		502
S3	2,500	Combi1/1	-163,25	12,72	0	97	0		502
S4	0,000	Combi1/1	-82,80	24,83	0	0	0		502
S5	3,000	Combi1/1	-42,20	91,43	186	347	898	3x20,0(942)	68
S6	3,000	Combi1/1	-33,58	96,23	195	347	974	4x20,0(1257)	68

TABLE 4. Reinforcement iso static calculation method

Design As EN 1992-1-1

Linear calculation, Extreme : Member

Selection : All

Combinations : Combi1

Main upper reinforcement for selected beams

Member	d_x [m]	Case	N_d [kN]	M_{yd} [kNm]	x_u [mm]	d [mm]	$A_{s,req}$ [mm ²]	Reinf.[no.]	W/E
S1	0,000	Combi1/1	-162,14	0,00			21	1x20,0(314)	2
S2	0,000	Combi1/1	-81,07	0,00			21	1x20,0(314)	2
S3	1,000	Combi1/1	-161,59	-15,20	0	97	0		502
S4	1,000	Combi1/1	-80,52	-15,20	0	97	0		502
S5	3,000	Combi1/1	-45,00	119,12	232	347	116	1x20,0(314)	65
S6	3,000	Combi1/1	-22,50	119,12	232	347	84	1x20,0(314)	65

Main lower reinforcement for selected beams

Member	d_x [m]	Case	N_d [kN]	M_{yd} [kNm]	x_u [mm]	d [mm]	$A_{s,req}$ [mm ²]	Reinf.[no.]	W/E
S1	0,000	Combi1/1	-162,14	0,00			21	1x20,0(314)	2
S2	0,000	Combi1/1	-81,07	0,00			21	1x20,0(314)	2
S3	2,500	Combi1/1	-160,76	-9,96	75	97	417	2x20,0(628)	67
S4	0,500	Combi1/1	-80,79	-9,96	71	97	299	1x20,0(314)	67
S5	3,000	Combi1/1	-45,00	119,12	232	347	1261	5x20,0(1571)	
S6	3,000	Combi1/1	-22,50	119,12	232	347	1294	5x20,0(1571)	

In TABLE 3 and TABLE 4, the necessary quantity of reinforcement steel is shown. For every beam and column, six in total, the reinforcement steel is given. This is calculated with SCIA Engineer 14. When comparing both tables, it is clear that the hyper static calculation method requires significantly less steel than the iso static calculation method. This shows that the demountable building method requires more material than the classical building method for realizing the same construction. Appointing percentages to the extra amount of material is not done here, since this is just a theoretical example and the number would be deceiving.

8.1.2 Fire resistance

An important parameter for a building is how well it performs in case of a fire. When a fire breaks out, the structure should hold up for as long as possible, to enable an evacuation. An increasing heat has an influence on the yielding of steel. The higher the temperature, the lower the yield strength will be. That is why concrete buildings have a way better fire resistance than steel buildings: the temperature first has to go through the concrete to reach the steel reinforcement bars, while in a steel building, the steel is directly exposed to the heat of the fire and will start to yield way faster. For a demounta-

ble building that exists of concrete components that are joint together with steel connections, the fire resistance will only be as good as the weakest link, which would in this case be the steel joints.

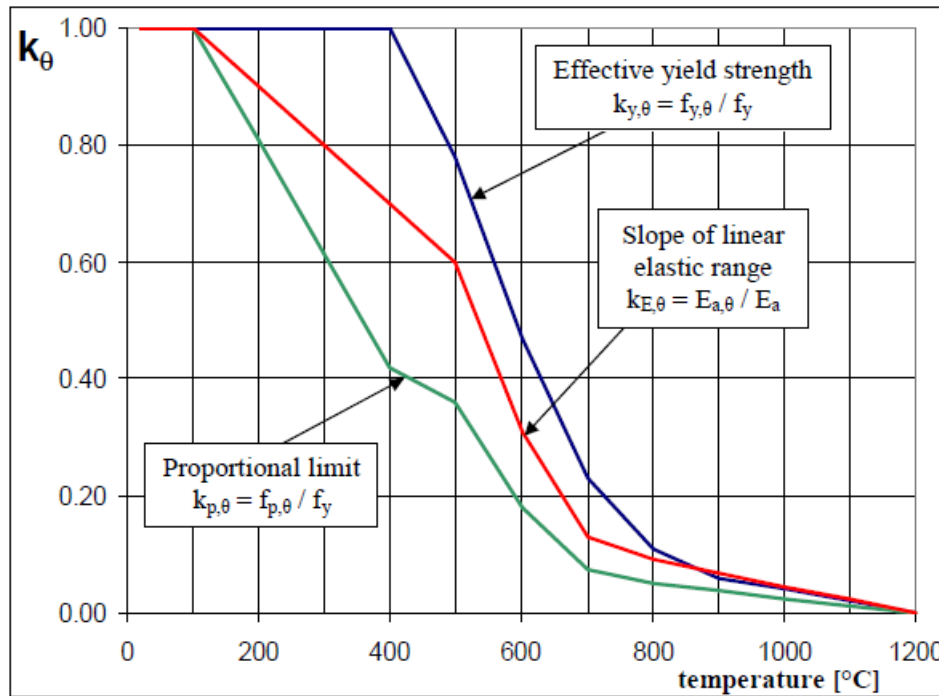

FIGURE 4. Reduction factors for steel strength and stiffness at elevated temperatures (Fire resistance 2006)

On FIGURE 4, a visual rendition of the decrease of the strength and stiffness of steel in function of the temperature is shown. The factor k_θ indicates how strong the load bearing capacity changes. Using this curves, the temperature for which failure would occur can be determined. In order to protect the steel from fire, some measures need to be taken. An effective way to increase the fire resistance is providing a cover on the steel. The cover should have a low thermal conductivity, which means that the heat does not reach the steel as easy as when there is no cover applied. The lower the thermal conductivity, the better the cover works, on condition that it is applied equally at all places.

In TABLE 5, the general properties of several cover materials are given. The most interesting one to look at when choosing a cover material is the value for λ_p , the thermal conductivity. It turns out that spraying the steel with mineral fibre or vermiculite cement perlite offers the best thermal conductivity, but the problem is that this will give problems when the pieces are to be taken apart again, since the wet method is used to apply the spray. It might be better to use boards. The value is slightly worse, but the advantage

is that there is a clear separation between the fire protection and the steel piece itself, which is necessary if it is to be demounted later on. The boards are heavier than the spray, except for the compressed fibre boards, which are even lighter than the sprays. In order not to disturb the stability of the structure, this might be the best option, but it will also be the most expensive one. Covering the steel with concrete or bricks seems irrelevant for this application.

TABLE 5. General properties of cover materials (Fire resistance 2006)

Material	Unit mass ρ_p [kg/m ³]	Thermal conductivity λ_p [W/(m.K)]	Specific heat c_p [J/(kg.K)]
Sprays			
- mineral fibre	300	0.12	1200
- vermiculite cement	350	0.12	1200
- perlite	350	0.12	1200
High-density sprays			
- vermiculite (or perlite) and cement	550	0.12	1100
- vermiculite (or perlite) and gypsum	650	0.12	1100
Boards			
- vermiculite (or perlite) and cement	800	0.2	1200
- fibre-silicate or fibre calcium-silicate	600	0.15	1200
- fibre-cement	800	0.15	1200
- gypsum board	800	0.20	1700
Compressed fibre boards			
- fibre-silicate, mineral-wool stone-wool	150	0.2	1200
Concrete	2300	1.60	1000
Light weight concrete	1600	0.80	840
Concrete bricks	2200	1.00	1200
Bricks with holes	1000	0.40	1200
Solid bricks	2000	1.20	1200

8.2 Selective demolition

A building consists in general of two parts: the bearing structure and the finish. During the lifetime of the building, it mostly will be the finish that is damaged by the user: floors will wear, paint and plaster will get damaged,... When the building is ready for

dismantling, the structure and the finish should be separated. Everything that can be taken out without damaging the structure, should be removed. Those finishing elements are often easy to recycle or dispose. Think for example about wooden floors or gypsum wallcoverings. It is important that the stripping of the building happens without damaging the bearing structure. This will result in different processes than those that are common nowadays. A good planning and organisation is absolutely necessary, with special attention to not damaging anything. The bearing structure is harder to recycle and dispose of, so other solutions, such as demountable building, should be found.

While dismantling the building, safety is really important. Taking a look at the building is necessary: a lot of changes will have been made that will not always be indicated on the building plans. Good communication is inevitable. Everybody who is involved in the building process should be informed really well about the hazards and the dangers. Are there hazardous materials present? Is the structure sufficiently strong at all places? It is important to make a good planning so the storage of the material on site does not disturb the workings on the stripping of the building. Taking out fraction by fraction is obviously the ideal scenario, but it has to be checked if this is technically and economically possible. Another option is to dispose of all the different material fractions at once and having them sorted out later at the waste management company. It is more likely that this option is chosen in bigger cities, where there is less space available to install containers or separation units on the construction site.

8.3 Transport, storage and database

Changing the way of construction will cause a lot of side effects, also for the logistic side of the building process. It is likely that other equipment will be necessary to construct or demount and there are also some other aspects that will be introduced to the building process. First of all, there will be a whole new side to the transportation. Instead of only transporting the materials to the construction site, it will become necessary to be able to transport components as a whole from and to the appropriate location. Another thing that needs to be considered, is the storage of the demounted units, and the ability to take note of the available pieces.

8.3.1 Transport

A big thing to consider when working with precast elements, is the possibility to transport them from one site to another, without having to make excessive costs and disturbing the normal traffic. Probably the best way to transport is by truck, since those can access most of the construction sites easily. When talking about Europe, there is a solid road network, which results in a quite efficient way of transportation. Other transportation methods that can be used are railways or waterways. The disadvantage those have, is that they are harder to access than regular roads, are slower and way more unusual. It is obvious that those methods will only be used on certain occasions, in which they turn out to be more favourable than transportation by truck.

Transport is the biggest limiting factor when it comes to the size of the components. Also for modular building, this is what defines the maximum size of the modules. The Belgian company Skilpod produces modules which have a maximum size of 4m to 12m, and those measurements are solely defined by what is transportable by truck.

8.3.2 Storage

It is not very likely that a construction component can immediately go from a demounting site to a new construction site where it will be reused. There will be some time in between the demounting and the reuse, so there will also be a certain need for storage space during that time. The easiest way to organise this, is probably by having some central storage points, managed by one instance that controls the in- and output of the components. Nowadays, there is no such thing, so this is an unexplored market that can lead to job creation and work opportunities.

8.3.3 Database

Demountable building can only be feasible if contractors or building companies start reusing components that come from other construction sites. In order to make this happen, it is necessary to have some knowledge about what components are available and in what condition they are. A suggested way to do so is by using an online database or market place, strictly for construction components. This database can hold all the important information about the available components, so it is easy for designers to check

on what components they can use. The information that is stored in the database can be drafted out of BIMs, since those hold important information on the construction elements anyhow. More information about the possibilities of Building Information Modeling (BIM) is found in chapter nine.

On the 17th of January 2011, a project called IRCOW (Innovative Strategies for High-Grade Material Recovery from Construction and Demolition Waste) was initiated. The project ran for 36 months and was a collaboration between a lot of partners from different countries. The main goal of the IRCOW project was to develop and validate upgraded technological solutions to achieve an efficient material recovery from construction and demolition waste by considering a life cycle perspective. One of the results of the project is the “IRCOW C&D reuse platform”. This is an e-platform to facilitate and promote the reuse of materials and elements recovered from construction, demolition or renovation works. The C&DW StockExchange is an online market place and is up and running only in a demo version for now. However, it is a good example of what is meant with a database. The system has a geographical scope, which enables the user to search for elements that are nearby, which will reduce the transport costs. (IRCOW)

8.4 Quality loss

8.4.1 Concrete

Once concrete is damaged, it is hard to repair it to its original state. Concrete repair techniques will also never improve the strength or performance beyond the original condition. Concrete is generally speaking a durable material, but it can also degrade a lot. If concrete elements are to be reused, it needs to be assured that their quality is still sufficient and will be during the necessary lifetime. There are a lot of ways how concrete can lose its quality and therefore not be suitable for reuse anymore. A lot depends on the environment in which the concrete is used. Outside applications will in general generate more quality loss. It is well known that environments such as coastal or industrial environments will influence the durability of the concrete in a bad way, due to the substances which come into contact with the concrete. The most common causes for concrete degradation are damage by fire, the alkali-silica reaction, carbonatation (which implies corrosion and expansion of the reinforcements bars), other chemical damage and physical damage.

When a concrete element is to be reused, it is important to have it guaranteed that its quality is sufficient. It needs to be certain that it does not compromise the structure of the building. An expert should be assigned to run a series of tests on the concrete elements to check their capability of being reused. There are several techniques to check the quality of concrete, with the division between destructive and non-destructive tests. The former obviously cannot be used to check the quality, so only non-destructive tests, from which the most common are the visual inspection, radiographic and ultrasonic testing.

8.4.2 Steel

The most common way of material degradation for construction steel is corrosion, also called rusting or oxidation. It is an electrochemical reaction that occurs when iron atoms loose electrons in the presence of oxygen and humidity. An effective solution to prevent corrosion is excluding the possibility of the steel getting into contact with water, either by applying a coating or a viable building envelope. Obviously, the environment around the building influences the risk of corrosion, as well as the position of the element (interior or exterior). Each case should be considered on its own. If a steel element is to be reused, it should be investigated if it is still suitable.

8.4.3 Wood

The degradation mechanisms of concrete and steel are mainly chemical reactions. Unlike those, the principal degradation mechanisms for wood are biological attacks, such as bugs and fungi. Fungi need oxygen, moisture and mild temperatures to thrive. There are several ways to prevent wood from rotting, such as a thermal or chemical treatment, applying of varnish coatings, ... However, if wooden elements are to be reused, they should be checked for damage and approved as suitable. (Exponent Inc. 2010)

9 BUILDING INFORMATION MODELING

9.1 Definition

Building Information Modeling or BIM is a digital representation of physical and functional characteristics of a facility. A BIM is a shared knowledge resource for information about a facility forming a reliable basis for decisions during its lifecycle; defined as existing from earliest conception to demolition. Eventually, BIM helps everyone on the design team to make better decisions. The model not only shows a client what a building will look like, but it also gives the client and designer a better understanding of how the building will function after final completion. BIM is about better communication between all stakeholders, which leads to better collaboration and higher efficiency.

As often thought, Building Information Modeling is not a software or a specific program, but a concept and a way of getting organised. Instead of only storing the physical information of a structure, now all the intelligence that is related to the structure will be available in the model. This information is a new dimension that is added, compared to 3D drawings or plans. It is often said that the main cause of all problems is a lack of good communication. Building Information Modeling is a tool to create clearness about all information and thus reduce the errors due to insufficient communication.

9.2 Common features of BIM

There are a number of features that are or should be common in a Building Information Model. First of all, it is obvious that the BIM is a combination of 3D models which can be looked at from different angles and views. The line weights need to be controlled, following the principle of “what you see is what you get”. For example, if a wall has a certain thickness in the model, it should correspond with the thickness it will have in real life. The model needs to be able to facilitate the visualization, therefore making it easier for all project parties to understand the design. As an example, it needs to be possible to have photorealistic rendering in order to give the designer and the customer a clear image of what the building is going to look like in its final stages, even before the start of the construction work. Another feature is clash detection. The model has a certain intelligence and detects possible errors or mistakes that otherwise would be no-

ticed during construction. That way, the amount of errors that would cause delay to the planning are reduced, which results in a faster and more efficient way of working. These clashes can be physical problems, such as a beam clashing with a wall, but also soft clashes that can cause construction problems, such as obstructed access or limited headspaces, for example. Finding clashes on site is economically speaking much more favourable than finding them on site. Next to that, a BIM includes information regarding costs. Since the model stores information about the nature of all the elements and materials, it is possible to make an accurate cost analysis. This is favourable for the customer, since he will have clearer expectations of what the building is going to cost him. Perhaps the most important feature is the ability to have a clear view on the construction phasing. With BIM, it becomes possible to have an accurate estimation of the time that is needed to complete the work and to have more control on the schedule management. Time can be seen as an extra dimension to the 3D model.

9.3 Required features of a BIM system

In order to give a real added value, a BIM system should include some other necessary features. It should be easy to create construction documents out of the model, such as construction plans, schedules or information on the elements. There also should be a dynamic link between the model and those documents. Adapting one should imply adapting the other. Another necessity for a BIM is that it is understandable and easy to read for a lot of people. That way, the information on the building can be shared with exterior parties such as consultants or suppliers, in order to get the best possible advice and deals on the project. In other words, a BIM needs clear standards that are as universal as possible. As a last required feature, it should be possible to apply BIM to any kind of project, from new buildings to renovation works. The system is flexible and can be implemented for these different kinds of work.

9.4 The importance of BIM for demountable building concepts

After the short introduction to Building Information Modeling, it is important to take a look at what it can mean for demountable building concepts. BIM can be the tool that enables the concepts to work, given that it can provide solutions for issues that raise themselves when developing the concept. Some of these issues are listed below, with a suggestion of how BIM can be of help.

9.4.1 Characteristics of the elements

When a building is erected, the technical information is known by some of the people in charge, for example the architect and the responsible engineer. After the building is completed, the information on the specifications might easily get lost or forgotten, and it becomes practically impossible to know what the building really consists of. For example, the amount of reinforcement steel in a concrete beam or the distance between the braces is not visible anymore after the beam has been manufactured. The same goes for columns or walls. To the designers, this is crucial information if the element is to be reused, so it is necessary to have knowledge about it. In a BIM, all the necessary information can easily be stored and tracked down afterwards. Also certificates and information about the fabrication or previous use can be stored here. As an example, a concrete and a steel beam are compared to each other in TABLE 6 below.

TABLE 6. Information on construction elements

Data	Concrete beam	Steel beam
Amount	15	8
Material	<ul style="list-style-type: none"> • Reinforced concrete • C30/37 – S235 • rebar 628 mm² (bottom), • rebar 226 mm² (top), • concrete coverage of 35 mm, • braces 101 mm², distance between them 150 mm 	<ul style="list-style-type: none"> • Steel S235
Dimensions	<ul style="list-style-type: none"> • Length = 500 cm • Width = 200 mm • Height = 400 mm 	<ul style="list-style-type: none"> • Length = 650 cm • HEB 250
Type	Interior	Interior
Year of origin	2001	1997
Condition	Sufficient	Sufficient
Location	Helsinki	Turku
Other remarks	Minor cracks in the centre, though not compromising for the stability	none
Price	€ 500 each (transport included)	€ 300 each (transport included)

9.4.2 Transferring the information

When designers want to implement second-life elements in a building of theirs, they need to know what the properties of those elements are. By receiving and analysing the BIM of the building where the elements were used before, they can have a clear view on all the necessary information. That way, they can look for a similar application in the new building. For example, if a beam was used to support the roof in the initial building, it might be wise to apply it in a similar way in the new building. However, if the stability is not compromised, the designer has the freedom to do as he chooses.

The important thing is that the designer transfers all the information from the old model to the new model, so it does not get lost. He can do it manually, but it would be better if there were a feature in the BIM software to simply copy the element from one model to another one. This would simplify the task of the designer and rules out human errors of forgetting certain things. All that is necessary, is to keep updating the information as the element is reused. By keeping track of all the possible information, designers and engineers get a better understanding of the building and the materials. It becomes easier to predict and avoid risks, which leads to more safety.

9.4.3 Example in Tekla BIMsight

The Finnish company Tekla, founded in 1966 and having its headquarters in Espoo, Finland, is the leading authority in computer software for model-based construction, building and infrastructure management. Their software Tekla Structures enables users to create and manage 3D models in concrete or steel and take them through the process from concept to creation. Tekla BIMsight is a managing software for building information models out of all applications. Tekla BIMsight has three main pillars.

- Combine models
- Check for conflicts from an early stage
- Efficient communication between all involved parties

The pillar of “efficient communication” is the most interesting one regarding demountable building. The software is built to enable the user to share information. It is easy to add notes to each element or a series of elements in the model. These notes can be consulted by anyone who gets access to the model. The notes can be classified, so there can

be a note about the characteristics, about the condition, about the price, ... or one note about everything combined. PICTURE 18 shows an example of a drawn building that was analysed in Tekla BIMsight. The software shows a clear overview of the 3D model. On PICTURE 19, a detail from this view is shown. It shows a note that was added to all 72 beams in the structure, giving information about them. This information is accessible to everyone who opens the model, since it is entered as a public note. This is only an example of how the information can be transferred by using BIM. For the concept to really work, clear standards should be developed and introduced to all companies that participate. The information that is stored in the BIM should be compatible with the data that is necessary for the database as described in chapter eight. The example on PICTURE 19 illustrates a part of this information.

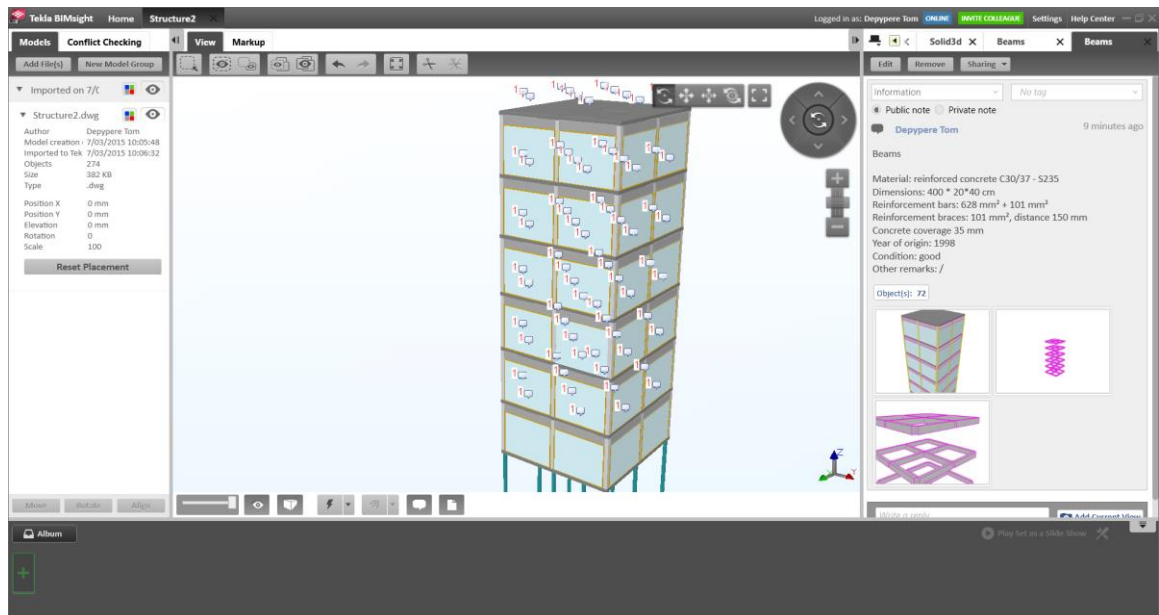

PICTURE 18. View in Tekla BIMsight

Information ▼ No tag ▼

Public note Private note

 **Depypere Tom** 9 minutes ago

Beams

Material: reinforced concrete C30/37 - S235
Dimensions: 400 * 20*40 cm
Reinforcement bars: 628 mm² + 101 mm²
Reinforcement braces: 101 mm², distance 150 mm
Concrete coverage 35 mm
Year of origin: 1998
Condition: good
Other remarks: /

Object(s): 72

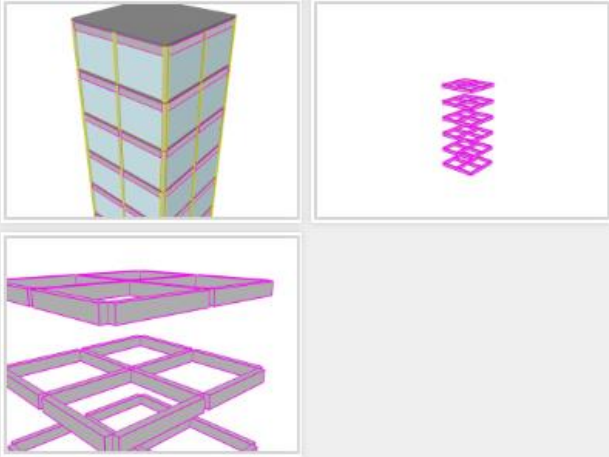

PICTURE 19. Public note in Tekla BIMsight

10 ECONOMIC BALANCE

As shown before, demountable building concepts have certain advantages and disadvantages compared to the classical way of building. An interesting and important criteria is the economic side of the story. Can demountable building concepts turn out to be profitable in the long haul? It is hard to come up with an indefinite answer to the question. There are a lot of factors to be taken into account and there are always unforeseen circumstances. Added to that, not one building is equally the same as another one and a lot of costs differ from situation to situation. However, it is worth investigating this economic balance and compare the demountable building concept with the classical way of building. In this chapter, an attempt is made to financially compare both ways of constructing.

10.1 Parameters

In a building process, there are several parameters that influence the final cost of the work. Those parameters can be used to make an economic balance. NCC, one of the leading construction, property development and infrastructure companies in Northern Europe, ranked the following parameters from most influential to least influential. The number assigned to the parameters means the following: one being the most influential and six being the least influential.

1. Salaries
2. Raw materials
3. Preparations and planning
4. Equipment and machinery
5. Design
6. Facilities

Accrediting a percentage is practically impossible, since every project is different and only an accurate economical study by an experienced calculator might give a final conclusion. However, in the words of NCC, “salaries and raw materials dominate this ranking” and are significantly the most important costs. Below, each parameter will be discussed and viewed from the side of demountable building concepts and the classical building methods. By comparing them that way, an estimation of the economic feasibility can be made.

10.1.1 Salaries

The wages form the most significant cost in a building process. The more people that are involved in the process and the longer it takes to complete it, the higher the costs rise. By using less people on the construction site or using less time to complete the construction, this cost can be cut back. The demountable building method and the classical building method can be compared with each other.

The demountable building method should require less assembly time on the construction site: the construction can proceed fast since everything is prefabricated. On FIGURE 5, a schedule is given to show how the time savings are realised. Since a lot of the activity does not take place on the construction site itself, less time on site will be necessary. The schedule goes for modular construction, but the principle is more or less the same as demountable building. More different parties are involved for the demountable building method. Manufacturing factories, administrative costs and workers for the storage and transport facilities need to be paid. However, there will also be supplier and transportation costs for the classical building method.



FIGURE 5. Time savings (Modular building 2015)

The biggest difference between the two methods seems to be the time that is needed for completing the construction process. Although there are more parties involved, the demountable building process appears to be the favourable option on this criteria. Due to better planning and reduce of risks and errors on beforehand, mostly because of the use of BIM, the construction time will be shorter. The amount of needed workers will probably not differ that much.

10.1.2 Raw materials

In a classical building process, the raw materials follow a certain series of steps. First of all, they need to be mined from the earth. After that, they are treated and made ready to be sold. Then they are purchased and transported to the construction site or manufacturing unit, to be finally applied in the building. After the end of the lifetime of the building, they will turn into waste and need to be disposed of.

In a demountable building process, the steps that the raw materials undergo are slightly different. The first time, they need to be mined as well, but here it is assumed that the work is performed with elements that are already manufactured and thus reused. Mining becomes unnecessary, although this cost will be replaced by the costs for the storage of the elements and the maintenance of the database and trading system. Since this system does not exist nowadays, it is impossible to know for sure how these costs will compare to the cost of mining. However, the recent developments regarding mining show that mining resources becomes more and more expensive. New regulations are limiting the possibilities of mining resources and since resources are not infinite, it is not unrealistic to assume that the costs of mining will keep on rising in the future. Next to that, after the lifetime of the building, the resources are not destroyed or degraded in quality. They come back to the market, which will definitely mean an economic advantage compared to the classical building method.

It is obvious that the raw material cost for demountable building concepts will be more favourable if they can be reused a lot of times. A big participation of the market is necessary to make the system feasible. The more the concept is used, the more profitable it will be. The initial costs might be higher, since a lot of new facilities need to be founded, such as the storage units, the distribution centres, the database, etc... Once this first leap is taken, it is likely that the system will turn out to be more profitable than the classical building method, since the problems with mining and disposing of construction and demolition waste are present and might only get bigger in the future.

10.1.3 Preparations and planning

The preparation phase for demountable building processes will be more complicated than for the classical building method. The whole process needs to be set out thoroughly from start to finish. Creating a BIM is more complicated than creating 2D drawings, although it eventually will result in more efficient results. Especially because there is no exquisite knowledge on the subject of demountable building, there are no set out guidelines and the preparations will take time, effort and thus money. On this parameter, the classical building process will be probably cost less than the demountable building process, since there is more routine and previous knowledge.

10.1.4 Equipment, machinery, design and facilities

The biggest piece of equipment that is present on a classical construction site is a crane. For large buildings, very often a tower crane is used. For a demountable building construction site, a crane is also essential, since the main activity on the construction site will be the assembly of the prefabricated elements. There will be less equipment necessary for a demountable building process on site, because a lot of the manufacturing happens off-site. Since these manufacturing processes happen off-site in a controlled environment, the machinery and equipment that is used for it, will wear out less fast. The amount of necessary equipment will probably not differ much between the two processes, but the demountable building process might require more transport, since every element needs to be delivered to the construction site. All in all, the estimation is that the costs will not significantly differ.

The design of the building is one of the less significant costs. Architects are used to designing buildings that are constructed by the classical methods. Designing demountable buildings will require some further training, but the costs of the designing phase will not result in higher costs for one of the two methods. The same goes for facilities such as electricity, running water, etc... The cost is not significant enough to make a big difference in the end.

11 DISCUSSION

The main aim of this thesis was to investigate the feasibility of demountable building concepts by analysing existing systems, determining the occurring difficulties and giving suggestions for new development on the subject. Providing a conclusive answer to the question whether or not demountable building concepts are more favourable than others cannot be given. However, the performed research shows that there are interesting possibilities and evolutions happening. Several existing systems were found in literature and are described in the thesis. By analysing the systems and discussing the concept with professionals, the possible challenges were determined. Based on information out of literature and other research, solutions for the main problems were suggested.

This thesis is not a handbook nor a step-by-step guide of how to create demountable structures. The development of a new method of construction requires a lot of time, financial resources and facilities. All these factors were not available during the writing of this thesis. Next to that, since demountable building concepts are not widely used, it is hard to find reliable relevant technical information. There are also no standards and no real experts on the matter. This leads to the fact that some parts of this thesis are more hypothetical than exact science. Their purpose is more to provide different thinking patterns.

The main conclusion that can be made out of this thesis is that there are currently a lot of different ideas and possibilities regarding demountable building. However, for the concept to be really workable and feasible, a certain standard should be introduced. If there would be a standard to work by, it would be easier for companies to participate in the initiative. The more participation, the more profitable it would get. The biggest problem is that the first steps are hard and will require a lot of investments. In any case, the construction industry seems to be taking steps in the right direction. The development of patents in the mid-20th century, changing to the construction of real buildings in the beginning of the 21th century shows that there definitely is progress in the field.

This thesis should be considered as an assembly of introductory information to demountable building concepts. This information can serve as an inspiration for developers and designers. It is a describing work that can provide interesting insights. There are a lot of opportunities for future research on the subject. The development and testing of

a real demountable structure is definitely the most interesting, but also the most challenging one. Innovative construction companies can outsource this to their research and development sections and might become pioneers for demountable building. During these developments, the hypotheses that are made in this thesis can be tested and whether or not verified. It is a certainty that this will take time and that a lot of financial input will be necessary, but it can lead to a lot of new perspectives for the industry and job creation. The writing of standards should also be included in this development. Next to that, the development of a supporting software package is probably necessary. This can be a tool to make demountable building concepts workable. It can be an extension of existing software, but also a new package. The necessary features of Building Information Modeling should be further explored, optimized and implemented in this software.

REFERENCES

B. De Ridder, G. Goeminne, B. Mazijn, G. Vanhoutte, J. Backaert, J. De Mol, J. Van Roo. 2002. Berekening van de grondstoffenconsumptie in Vlaanderen (1991-2001). Ghent: Mira, 21

Roman Concrete. 1999. David Moore. Read 22.04.2015.
<http://www.romanconcrete.com>

World Population. 2014. Geohive. Read 18.11.2014. <http://www.geohive.com>

RAU. 2015. About Rau. Read 25.4.2015. <http://www.rau.nl/>

W. Hansen, M. Christopher & M. Verbuecheln. 2002. EU Waste Policy and Challenges for Regional and local Authorities. Berlin: Institute for International and European Environmental Policy, 4

Concrete solutions. 2013. Kris Broos. Read 12.11.2014 <http://ec.europa.eu/>

Steel construction. 2001. End-of-life scenarios. Read 15.11.2014
<http://www.steelconstruction.info/>

EPB. 2014. Energieprestatieregelgeving. Read 18.10.2014. <http://www.energiesparen.be>

Modular Building. 2015. Why build modular? Read 17.2.2015 <http://www.modular.org>

Urban Mining. 2014. How urban mining works. Read 21.11.2014.
<http://www.urbanmining.org>

Gemima Harvey. 2013. The Potential of Urban Mining. Read 26.11.2014.
<http://thediplomat.com/>

Jeongsoo Yu, Jia Che, Michiaki Omura and Kevin Roy B. Serrona. 2011. Emerging Issues on Urban Mining in Automobile Recycling: Outlook on Resource Recycling in East Asia, Integrated Waste Management - Volume II, Mr. Sunil Kumar (Ed.). Shanghai: InTech

Koen Vandepopuliere. 2014. Duurzaam Nieuws. “Thomas Rau, vreedzaam terrorist.”
<http://www.duurzaamnieuws.nl/>

Precast. 2015. National Precast Concrete Association. Read 24.2.2015. <http://precast.org>

K. S. Elliot. 2002. Precast concrete structures. Oxford: Butterworth – Heinemann, 11, 21, 23, 41, 229

T. Kawakami. 2010. Technology Forecasters. Read 24.11.2014.
<http://www.techforecasters.com/archives/>

T. Graedel. 2011. The Bridge linking engineering and society. Read 24.11.2014.
<http://www.nae.edu/>

J. Yu, J. Che, M. Omura & K. R. B. Serrona. 2011. Emerging Issues on Urban Mining in Automobile Recycling: Outlook on Resource Recycling in East Asia. Read 24.11.2014. <http://cdn.intechopen.com/pdfs-wm/18486.pdf>.

A. Littleboy. 2014. How to create wealth from waste and reduce our landfill. Read 22.11.2014. <http://theconversation.com/>

T. Hakkarainen, A. Sarja. 1985. Connections between precast concrete elements. Espoo: Technical Research Centre of Finland, 88

Cement & Concrete Association of New-Zealand. 2010. Sustainability awards. Read 16.10.2014 <http://www.sustainableconcrete.org.nz/page/home.aspx>.

NZIA. 2015. New Zealand Institute of Architects. Read 10.04.2015. <http://www.nzia.co.nz/>

IFD Bouwen. 2014. Industrieel, flexibel en demontabel bouwen. Read 6.11.2014. <http://ifdbouwen.be/>

More Park. 2014. Demountable system benefits. Read 27.4.2015. <http://morepark.com/>

Flexible Housing. 2004. Flexible housing project. Read 18.2.2015. <http://www.afewthoughts.co.uk/flexiblehousing/>

IRCOW. 2014. Final summary brochure “innovative strategies for high-grade material recovery from construction and demolition waste”. Spain: Tecnalia research & innovation – construction unit, 26

M. Haller, L-G. Cajot. 2006. Fire resistance of steel structures. London: Arcelor LCS Research Centre, 4, 19.

Exponent Inc. 2010. Construction Materials (wood, concrete, steel). Read 21.4.2015. <http://www.exponent.com/>

LIST OF PICTURES

PICTURE 1. Ladder of Lansink (Hansen, Christopher & Verbuecheln 2002, 4).....	15
PICTURE 2. End-of-life scenarios (Steel construction 2001)	17
PICTURE 3. Alan MacDiarmid Building (NZIA)	36
PICTURE 4. Detail of foundation	37
PICTURE 5. Detail of connection	37
PICTURE 6. Detail of parking garage (IFD Bouwen 2014).....	39
PICTURE 7. Overview of parking garage (IFD Bouwen 2014).....	40
PICTURE 8. Company building Barco NV (IFD Bouwen 2014).....	41
PICTURE 9. Details of company building (IFD Bouwen 2014)	42
PICTURE 10. Connection piece.....	45
PICTURE 11. Connection piece.....	45
PICTURE 12. Connection piece.....	46
PICTURE 13. Beams	47
PICTURE 14. 3D rendition of the framework	51
PICTURE 15. Loads on the framework.....	51
PICTURE 16. Moments hyper static calculation method.....	52
PICTURE 17. Moments iso static calculation method	52
PICTURE 18. View in Tekla BIMsight.....	65
PICTURE 19. Public note in Tekla BIMsight.....	66

LIST OF FIGURES

FIGURE 1. Mind map.....	11
FIGURE 2. World Population (World population 2014).....	14
FIGURE 3. Material composition of a passenger car (Urban Mining in Automobile Recycling 2011).....	29
FIGURE 4. Reduction factors for steel strength and stiffness at elevated temperatures (Fire resistance 2006).....	55
FIGURE 5. Time savings (Modular building 2015).....	68

LIST OF TABLES

TABLE 1. SWOT-analysis demountable building concepts	27
TABLE 2. SWOT-analysis urban mining (The potential of urban mining 2013).....	30
TABLE 3. Reinforcement hyper static calculation method	53
TABLE 4. Reinforcement iso static calculation method	54
TABLE 5. General properties of cover materials (Fire resistance 2006)	56
TABLE 6. Information on construction elements	63

APPENDICES

Appendix 1. Report of company visit "Skilpod"

21/11/2014
Biesbosstraat 5
3670 Meeuwen
BELGIUM

The company

Three years ago, Filip Timmermans and Jan Vrijs came up with the idea to produce modular housing units. One and a half year ago, their company "Skilpod" was born. Their goal is to produce houses that could be transported from one location to the other. Enabling people to work from home in a private office block, giving elder people the chance to keep living with their families for a longer time and still having a living space for themselves or simply living in a modular housing: these are some aspects they hoped to improve. With their Skilpods, they bet on a very flexible way of living. Up to now, they have worked at 23 projects, and in December 2014, the company is moving to a bigger location, in order to work more efficient and being able to evolve into an important player on the European market, which is the initial goal of Skilpod.

Skilpod

Skilpods are removable, transportable housing units. These are modules that are easy and fast to build and install. The goal is to achieve a living quality similar to a regular house. In order to be sustainable, the Skilpods are as good as energy neutral. The Skilpod could also attempt to disconnect ground-ownership and home-ownership, something that might become much more a standard procedure than it is nowadays.

Questions and answers

Are Skilpods demountable?

The unit itself is not demountable, but by looking at a unit as a huge piece of material, it's a demountable building concept. It's perfectly possible to install a unit and take it away later, to use it somewhere else. It is a very flexible way of building.

What materials are Skilpods made of?

At first they mainly consisted of wood and steel, but the steel has been dropped because it was too heavy and quite unnecessary, so now they are made of wood, which is imported from Finland and Germany. There are also plastics used, like polyurea. The insulation is mainly PIR (Poly iso cyanurate).

Is it possible to pile Skilpods on top of each other and work with multiple floors?

Yes, it is. Skilpod has only produced units for a single floor, but the studies for multiple layers have been done and it won't be long before this becomes reality. The maximum capacity is 5 or 6 floors, but this is something Skilpod doesn't get into yet. Two floors will be the next step.

How are the joints made?

Multiple joints are fixed together with special screw plates and screws, and this is always done out of sight, so there is no esthetical discomfort. By working with wood, screwed joints are a simple and reliable solution.

What are the thermic and energetic capacities?

The standard that is the target for Skilpod is BEN 2020. Because the units are rather small, they take little energy to heat up. For small units, there can even be overheating just by the sun. A lot of energy is necessary to cool down the unit if that happens, but due to the using of a heat pump, this is not a big problem. The E-level of a unit amounts

25 to 26, which is certainly sufficient, compared to the prescribed value in the Belgian EPB-standards. The units are nearly energy neutral.

How are the units transported and installed?

The Skilpods are wrapped up when they are ready for transport and then put on a truck. The dimensions of the Skilpod are limited by the transport capacity. That's why a unit has the maximum dimensions of 4x13 m. The unit is lifted up with a crane and put into place.

What foundations can be used?

Most of the time, a screw foundation is used. This type of foundations suffices to carry the load of the Skilpod since it's a light construction. The biggest advantage of this kind of foundation is that it doesn't damage the ground, and therefore decreases it's value, by boring piles or trenching it. If it's desired, a concrete floorboard can be used.

What is the difference with HOB-units?

HOB-units are containers that are transformed into a living space. Skilpods are houses that are transformed into a transportable unit. The biggest difference is the quality of living, which is way better in a Skilpod than in a HOB-unit. The walls of a Skilpod, for example, are 25 to 30 cm thick.

Is there a market for it?

Yes, there is. The orders come in on a daily basis and the production for the coming months is already fully booked. Especially young people are interested. Skilpod is the only company in Belgium who makes this kind of units. However, it's hard to convince contractors of the advantages of this system, because they are set in their ways.

Appendix 2. System for joining precast concrete columns and slabs



US005809712A

United States Patent [19]
Simanjuntak

[11] **Patent Number:** **5,809,712**
 [45] **Date of Patent:** **Sep. 22, 1998**

[54] **SYSTEM FOR JOINING PRECAST CONCRETE COLUMNS AND SLABS**

6903098 9/1969 Netherlands .
 7209390 1/1974 Netherlands .
 1246178 9/1971 United Kingdom .

[76] Inventor: **Johan Hasiholan Simanjuntak, JI.**
 Darmawangsa XII No. 131, Jakarta,
 Indonesia

Primary Examiner—Christopher Kent
Attorney, Agent, or Firm—Christie, Parker & Hale, LLP

[21] Appl. No.: **870,086**

[57] **ABSTRACT**

[22] Filed: **Jun. 5, 1997**

[30] **Foreign Application Priority Data**

Jun. 6, 1996 [ID] Indonesia P-961540

[51] **Int. Cl.⁶** **E04C 5/08**

[52] **U.S. Cl.** **52/223.7; 52/236.8; 52/236.9;**
 52/251; 52/263; 52/283; 52/583.1; 52/585.1;
 52/742.14; 52/747.12

[58] **Field of Search** 52/223.7, 236.8,
 52/236.9, 251, 263, 283, 583.1, 585.1,
 742.14, 747.12

[56] **References Cited**

U.S. PATENT DOCUMENTS

3,562,979 2/1971 Ali-Oglu 52/236.8 X
 3,613,325 10/1971 Yee 52/236.8
 4,081,935 4/1978 Wise 52/236.8
 4,330,970 5/1982 Bonink .

FOREIGN PATENT DOCUMENTS

0004998 10/1979 European Pat. Off. .

A precast concrete system is provided that consists of columns and slabs joined together in one point. Each corner plate of the slab is equipped with a steel pipe mounted on a steel plate that is attached at and covers the top surface of the column. Each column is equipped with high tensile steel reinforcement strands protruding at the top end to penetrate the steel pipes of the four corners of four slabs, through the holes in the steel base plate attached at the bottom surface of the next column above it, and through the pipes implanted vertically at the lower section of the next column. The implanted pipes are in line with the holes on the base plate. The four steel pipes of four slabs meeting on one column are tied together with high tensile steel wire rope through three holes drilled horizontally at three places of the pipe length: upper, middle, and lower sections. The pipes of the slab corners and the gaps between pipes and slabs are filled with a special mortar cement that hardens fast. Then a special mortar cement is injected to the implanted pipes through each pipe's opening on the side surface of the column.

7 Claims, 8 Drawing Sheets

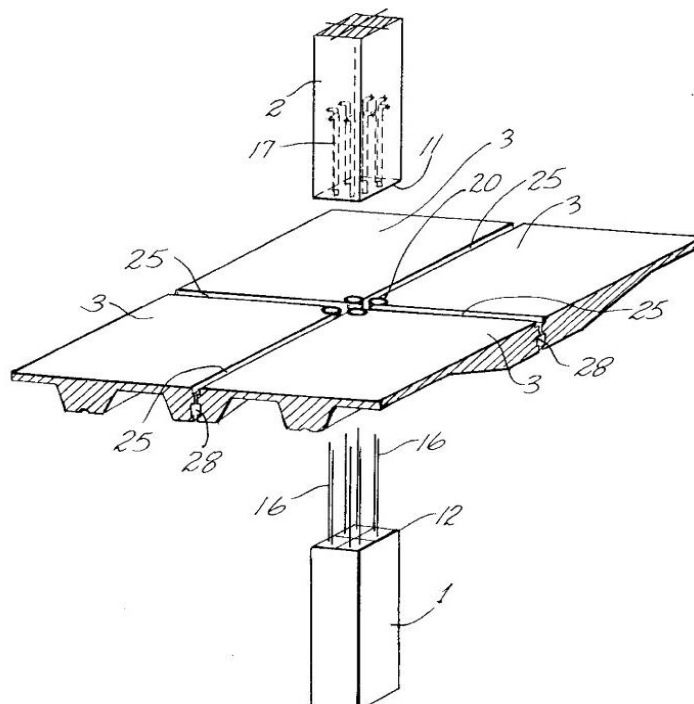
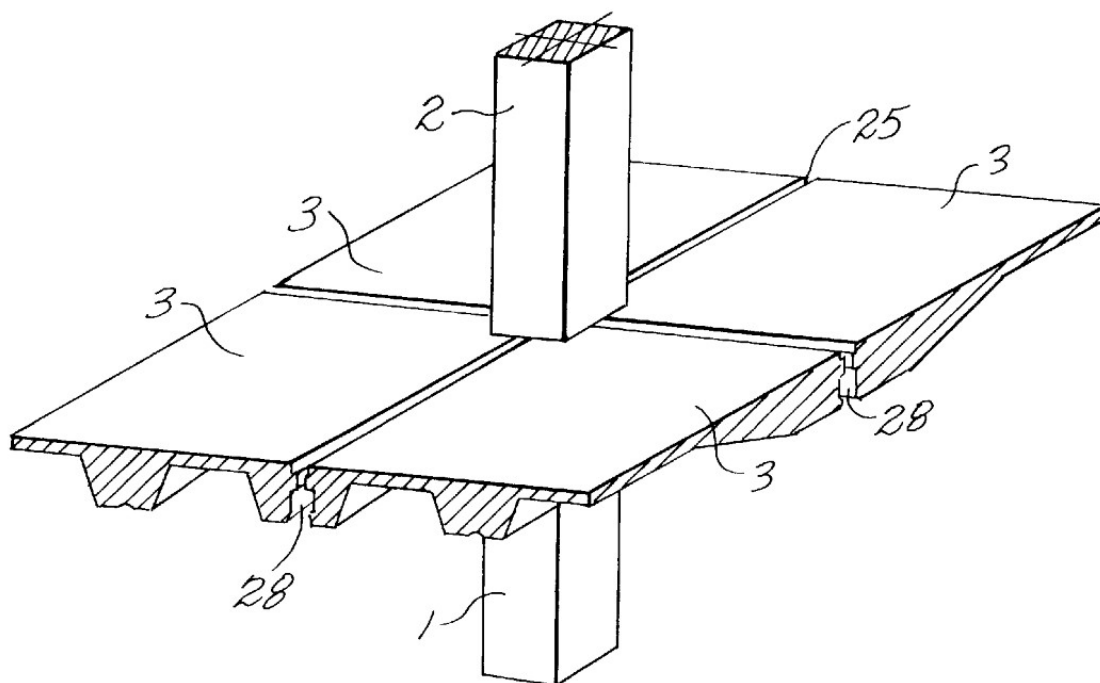

Fig. 2



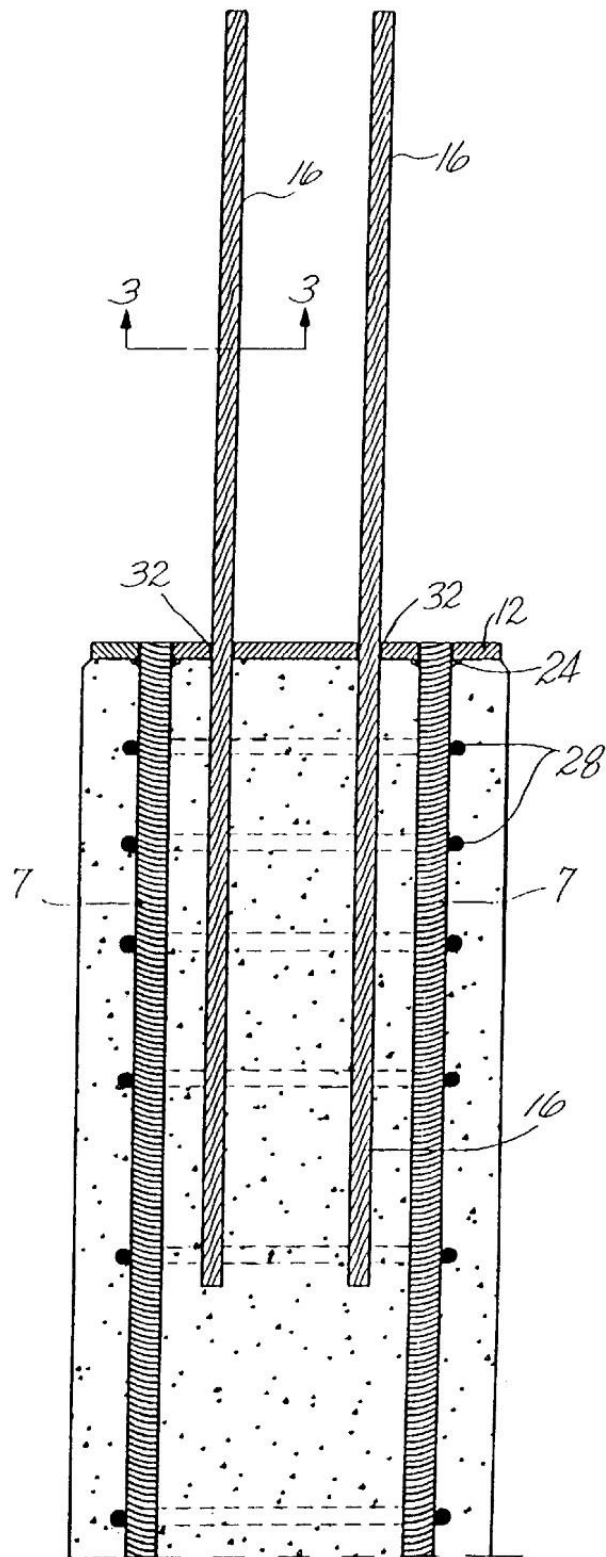
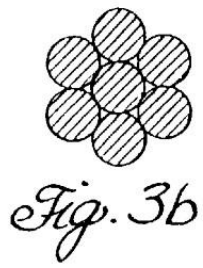

Fig. 4

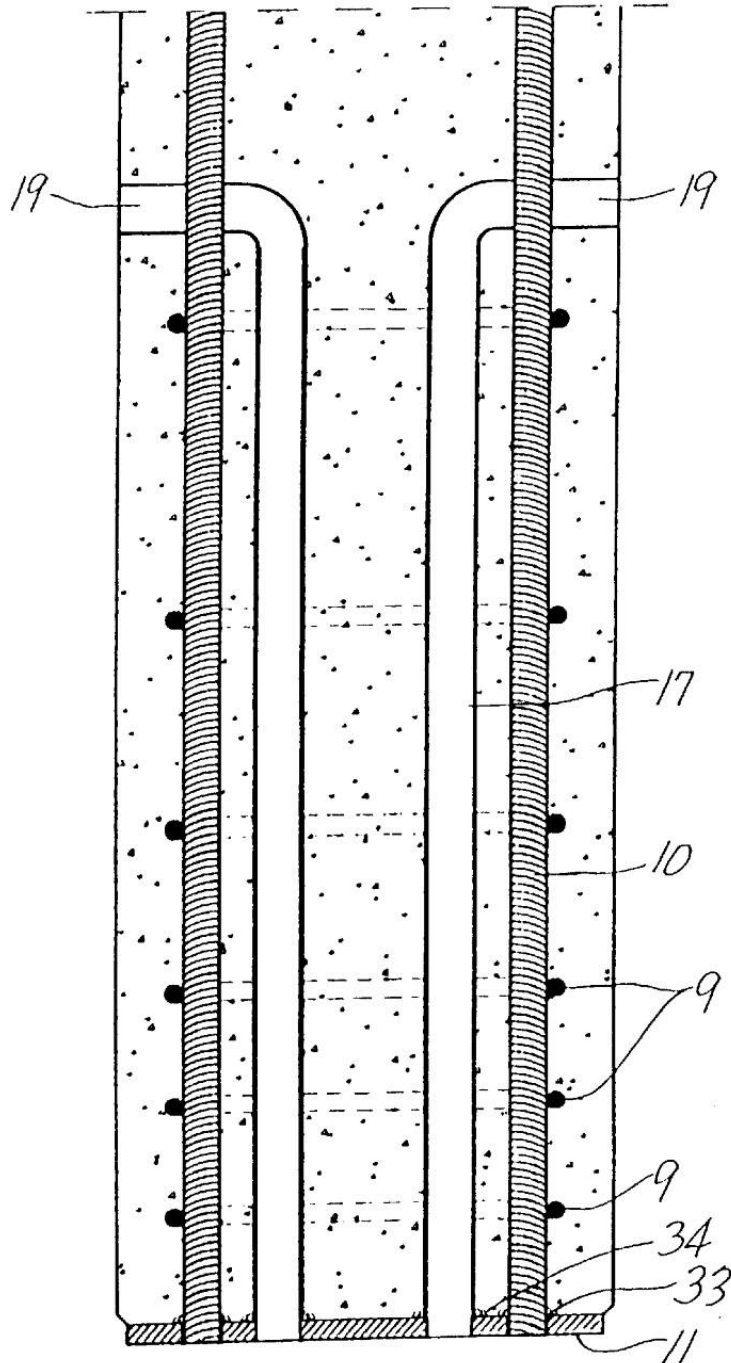
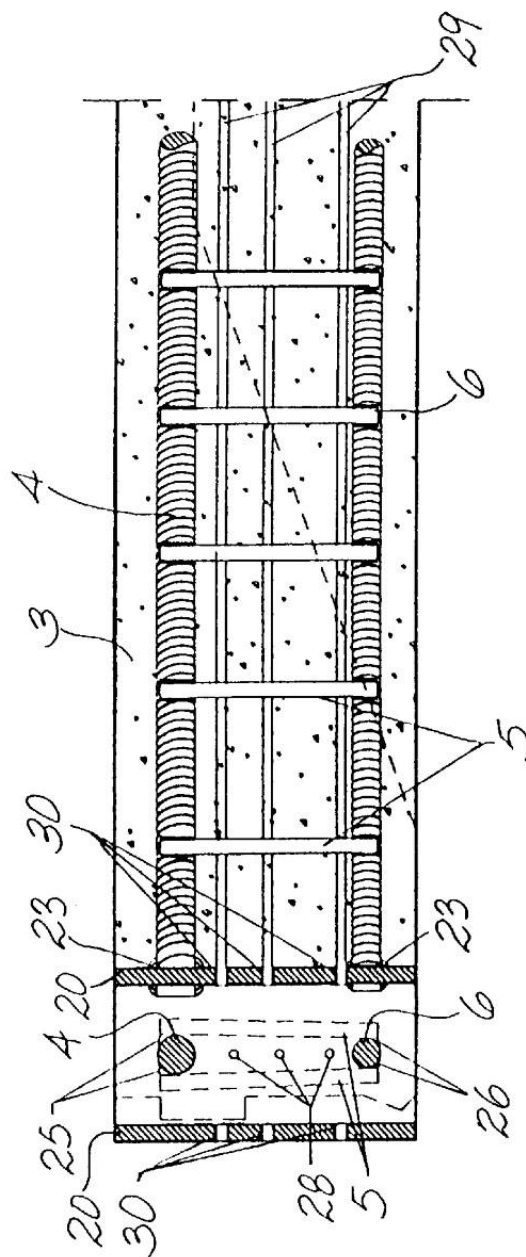

Fig. 5



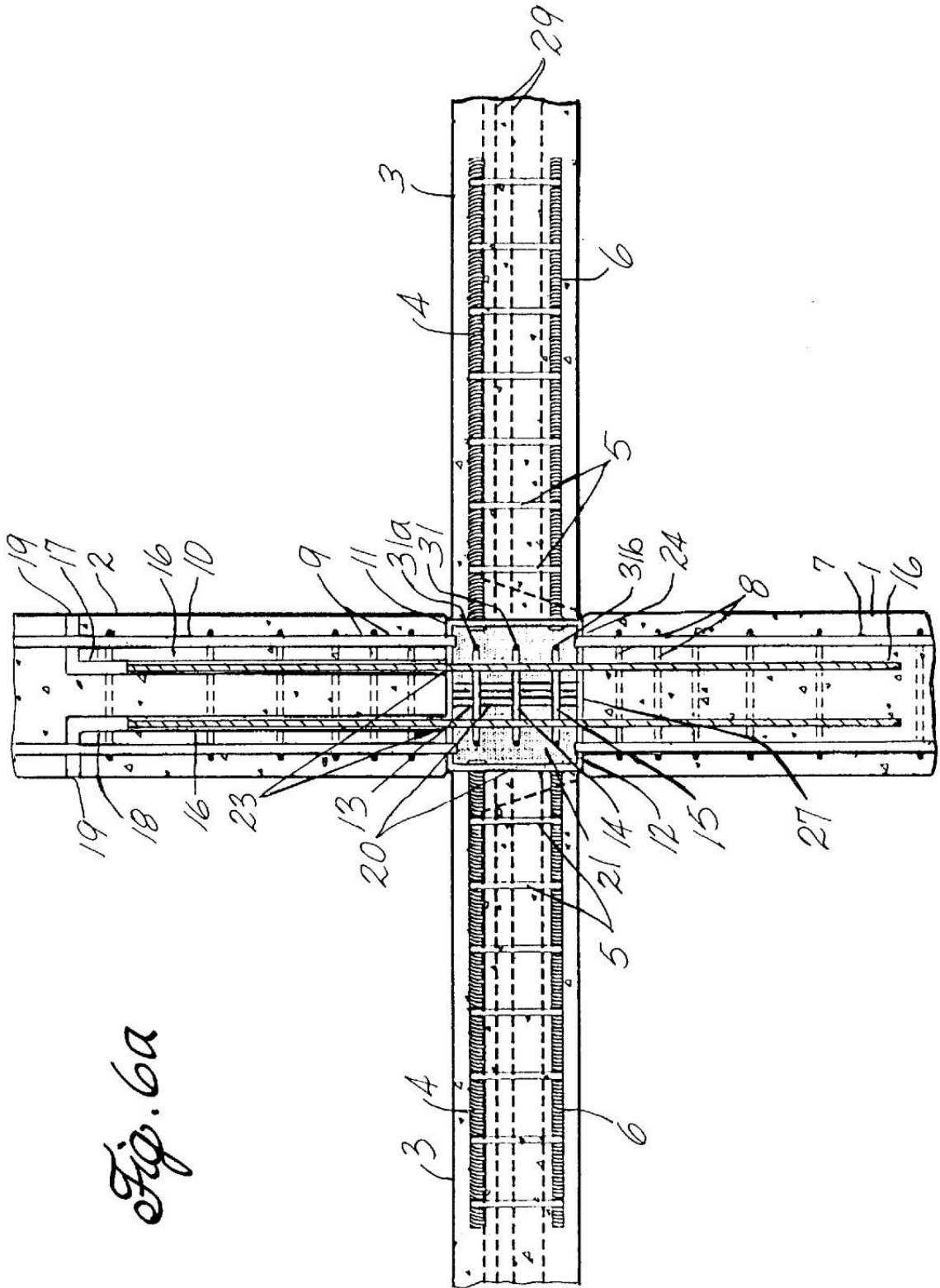

Fig. 6a

Fig. 66

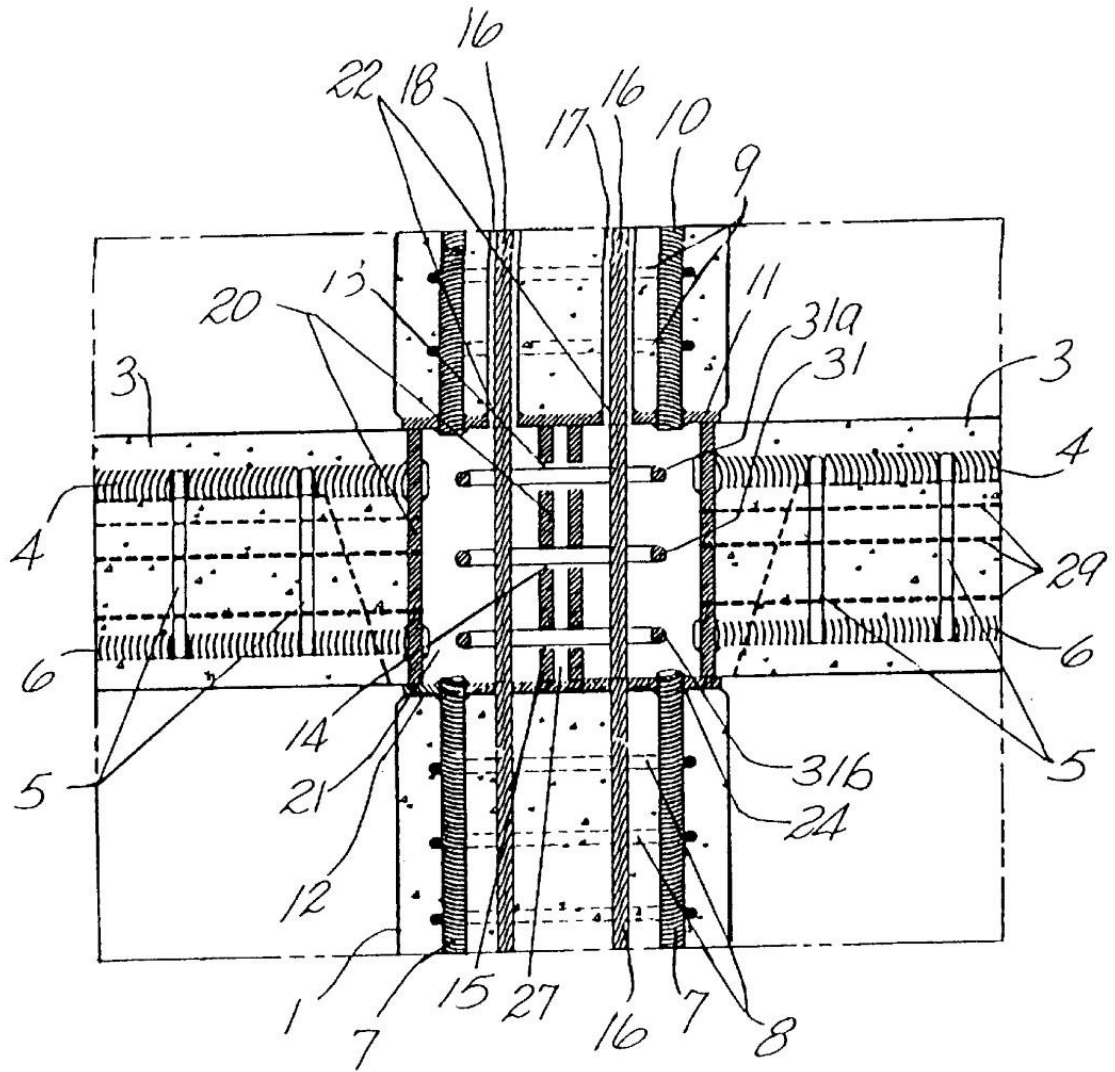
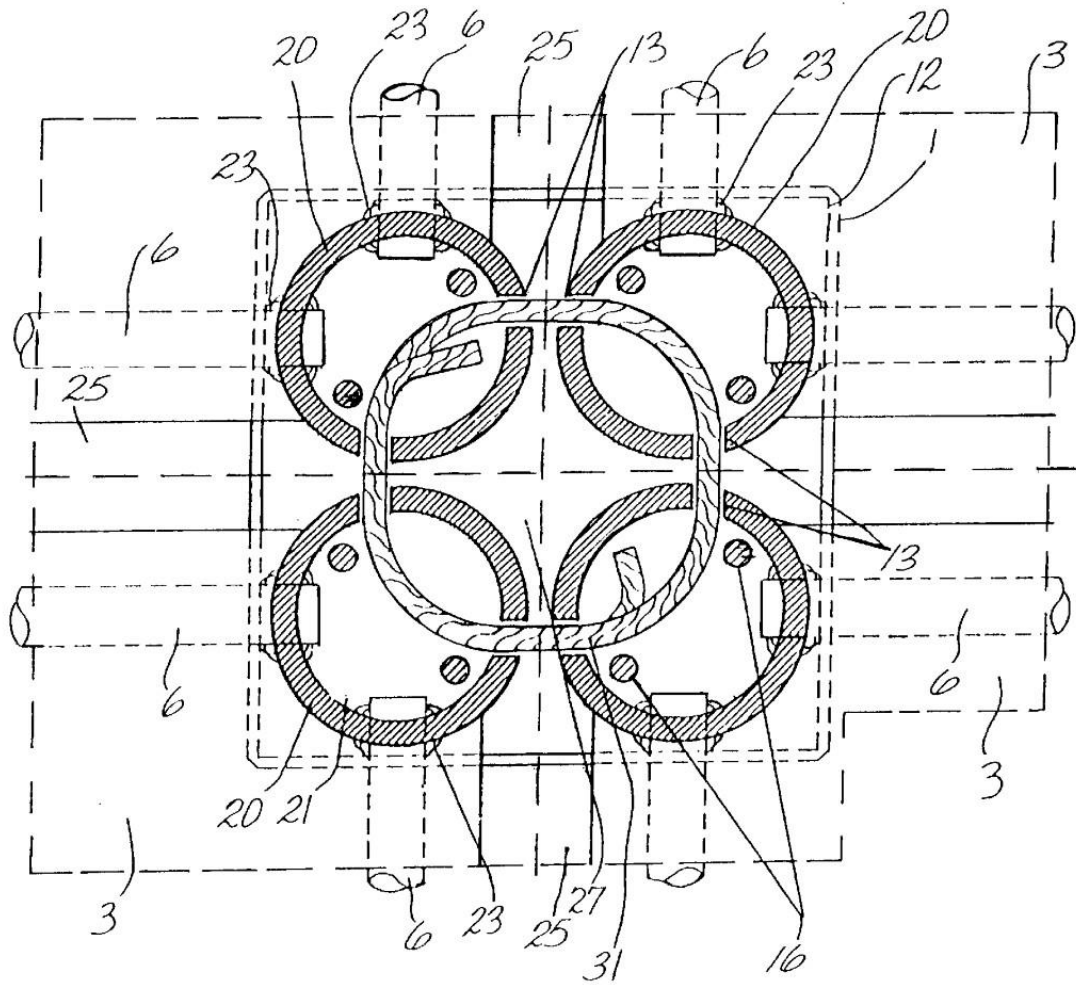

Fig. 7



SYSTEM FOR JOINING PRECAST CONCRETE COLUMNS AND SLABS

FIELD OF THE INVENTION

This invention concerns a method of constructing a multistory building from precast concrete using columns and slabs as its structural elements.

BACKGROUND OF THE INVENTION

The use of precast concrete components for multistory buildings has earned significant position in the building construction industry for the benefits it offers. Benefits include:

- Shorter construction time;
- Better quality assurance;
- Smooth concrete surfaces;
- Cleaner construction area; and
- Lower cost of production from standardized mass production.

In pre-fabricated precast systems, the joints between the components are the most crucial elements. Joining several precast concrete components in one single joint or at one place has to be done fast and efficiently, and more importantly is the assurance of its construction strength. The joint has to withstand all forces resulting from external load, such as its own weight, live load, and seismic forces. In the conventional construction system, where the columns, slabs, and beams are cast on site, structural problems at the joint between columns and beams or floor do not appear. As the components are cast on site together, they form a monolithic structure.

The use of precast concrete systems as the structure of multistory buildings has been limited by the difficulty in creating a joint system that is practical and economical, and able to overcome all forces resulting from its own weight, especially from seismic forces. Some popular and simple methods such as connecting columns and beams or floors with bolts or welding, have a handicap in their capability to withstand horizontal forces imposed by seismic forces. Those simple methods were designed only for withstanding gravitational force.

The objective of this invention is to produce a seismic resistant and fast method for connecting and joining precast concrete elements, consisting of reinforced concrete columns and beams, which indeed form the floor itself (hereafter called slab).

SUMMARY OF THE INVENTION

The floor element in this system is a panel made from ribs and concrete with thin plates in between, where the ribs function as beams. The sequence of assembling the precast elements is as follows.

Firstly, precast concrete columns are positioned vertically so that the steel anchors at the base floor fit in the steel pipe holes implanted in the lower section of the columns. Each concrete column is able to stand firmly by bonding it to steel anchors mounted on the base floor or at the head of the foundation. Special mortar cement is poured or injected through the other openings of the said pipes that are on the side surface of the column. The mortar cement flows down by gravity and fills up the passage of the pipes. As the mortar cement hardens, the column is sufficiently firm to stand without support. Then precast slabs are placed on top of the columns.

One slab with four corners is supported by four columns. One column is the junction of four slab corners of four slabs.

A column of the next story of the building is placed on top of the junction. Hence at one junction meet six ends of precast structural elements consisting of the top of the lower column, the four corners of four slabs, and the base of the next higher column, where they all form a single joint.

There is a structural bond among the reinforcement of the lower column, the structure of the four corners of slabs, and the upper column from the existence of high tensile steel strands rooted in the upper section of the lower column and anchored at the lower section of the upper column. There is also a structural bond among the slab corners by means of tying the steel pipes of the slabs' corners with high tensile steel wire rope through the holes drilled horizontally on the pipes' walls. The pipes and the gaps among the pipes are filled with mortar cement so that the wire rope and the four pipes of the four slabs come in contact and bind together. This system results in a practical and economical method of assembly and a reliable construction in terms of its strength. The following drawings are presented to illustrate the above description.

BRIEF DESCRIPTION OF THE DRAWINGS

FIG. 1 is an exploded perspective view illustrating the precast concrete elements of the invention;

FIG. 2 is a perspective view illustrating the assembled precast concrete elements;

FIG. 3a is an elevation view in section of a lower column;

FIG. 3b is a cross-section view of a steel strand taken along line 3—3;

FIG. 4 is an elevation view in section of an upper column;

FIG. 5 is an elevation view in section of a slab corner;

FIG. 6a and 6b are elevation views in section of the assembled elements; and

FIG. 7 is a plan view in section of an assembled joint between the elements of the present invention.

DETAILED DESCRIPTION OF THE INVENTION

FIG. 1 shows in perspective the precast concrete elements: the upper section of the lower column (1), the four corners of the four slabs (3), and the lower section of the upper column (2) separately before joining. On the top of the lower column (1), there are a number of steel strands protruding (16), which are embedded in the lower column (1). In the lower section of the upper column (2) are implanted a number of steel pipes (17) vertically positioned at the bottom surface of the column (2) and bent toward the side surface of the column, so the other openings of the pipes are on and flat to the side surface of the column. The number of the steel pipes (17) is equal to the number of the steel strands (16) protruding from the lower column (1). FIG. 1 shows a partial view of four slabs (3) between the lower column (1) and the upper column (2). The corner of each slab (3) is laid on the surface of the steel plate (12) that is mounted on the top surface of the column (1). Steel pipes (20) which are firmly integrated in a vertical position to the corner of the slab (3) will convey the steel strand (16) protruding from the lower column (1) to enter the pipes (17) in the lower section of upper column (2).

FIG. 2 shows in perspective the six structural elements in unity. A gap (25) between adjacent slabs (3) will be filled with special mortar mixed from portland cement, sand, and finely crushed stone. The perimeter of the slab has shear keys (28) which provide binding strength to one another at the meeting line.

FIG. 3a shows the vertical cross-section of a lower column (1). Steel strands (16) which penetrate through holes (32) on the steel plate (12) are made of high quality steel with flexible properties. A single steel strand (16) consists of seven steel wires, each of approximately 4 mm. diameter, as illustrated in FIG. 3b. A steel strand made of seven 4 mm wires is standard in production and commerce and is known as pc strand. The main reinforcements (7) are surrounded by a stirrup reinforcement (8), and the ends of the main reinforcement (7) are connected by welding (24) them to the steel plate (12) along the edge of the holes on the plate surface that is in contact with the lower concrete column (1).

FIG. 4 shows the vertical cross-section of the upper column, (2). The steel pipes (17) function to take the steel strands (16) from the lower column (1), and through the pipe openings (19) which are on and flat to the side surface of the column (2). The special mortar cement (18) is injected to bind the steel strands (16) and the pipes (17) together (see FIG. 6a). The bottom ends of the pipes (19) are welded at the edge of the hole (34) on the steel base plate (11) surface that is in contact with the bottom of the upper column (2). The ends of the main reinforcements (10) are welded to the edge of the hole (33) on the surface of steel base plate (11) that is in contact with the concrete column. Hence, the free outer surface of the steel base plate (11) is flat and smooth. The main reinforcement (10) is surrounded by stirrup reinforcement (9) at a predetermined distance.

FIG. 5 shows the vertical cross-section of a slab corner (3). A steel pipe (20) with a height equal to the thickness of the slab (3) is mounted perpendicularly to the two pairs of steel anchors (4 and 6) that are in perpendicular position to each other, by welding at the pipe holes (23), (25), and (26). A high tensile wire (29) of the prestress precast slab beam will slip through the holes (28) and (30) on the pipe wall (20).

FIGS. 6a and 6b show the vertical cross-section of the upper section of lower column (1), the slab side (3), and the lower section of the upper column, (2), in an integrated position as one single joint. The steel strand (16), protruding from the lower column (1), is inside the steel pipe (20) of the beam (3) and the steel pipe (17) of the upper column (2). The four steel pipes (20) of four slabs (3) have holes (13), (14), and (15) through which slips flexible wire rope (31), (31a), and (31b) to tie the four steel pipes (20) together. Each steel pipe (20) and the gap between the pipes are filled with mortar cement (21) and (27).

FIG. 7 shows the horizontal cross-section of the joint of four slab corners (3). The steel strand (16) protruding from the lower column (1) penetrates the steel pipe (20) of the slab (3), with two steel strands through each pipe (20). The drawing also shows a wire rope (31) tying together four steel pipes (20) through the pre-bored holes (13) on each pipe wall. The passage of the steel pipe (21), the gaps between pipes (27), and also the gaps between slabs (25), are filled with mortar cement. To the holes (23) of each steel pipe (20) are welded the ends of two pairs of anchors (6) in perpendicular position to each other.

As shown in FIG. 2, the precast structure components of the system are columns and slabs. The shape of the slab can be rectangular, but can also be a combination of small beams connected with thin concrete plates. The most important and critical part of construction is that the corners meet at the column ends. The firm integration of the structural elements which in this system consists of the joint of the top of the lower column with the bottom of the upper column, the joint of the top of the lower column and the four slab corners, and

the tying of the slab corners together, all in one single joint and the practicality in assembly are the essence of this invention. The interconnection of the reinforcement of each structural element meeting at the single joint is able to take and distribute vertical forces, horizontal forces, moment, and shear forces. This has been proven in a series of tests conducted by the Structural Laboratory of Housing Research Center, Department of Public Works of the Republic of Indonesia.

The steel strands (16) rooted at the upper section of the lower column (1) are to extend the reinforcement from the lower column (1) to the upper column (2). The passage of the steel pipe (17) with the steel strand (16) inside, is filled with special mortar cement so that the steel strand (16) adheres to the pipes, thus uniting firmly to the upper column (2). The adherence of the steel strand (16) and the lower column (2) results from the confined nature of the steel pipe (17) and the steel strand (16). For columns of 26x26 cm with four main reinforcement of diameter of 19 mm, to transfer maximum force that can be endured by the columns, that is from the lower column to the upper column or vice versa, eight high tensile steel strands of a diameter of ½ inch are used (16). From the technical specification of each main reinforcement (10) and steel strand (16), the tensile strength of two steel strands (16) is 2 to 3 times of the tensile strength of one main steel reinforcement (7) or (10). The high quality steel strand (16) consists of seven wires, each of 4 mm diameter. High tensile steel strands are commonly used for main reinforcement of prestressed concrete, but in this invention, the strand is not tensioned and does not function as prestressed steel. The characteristics of the steel strand suitable for this invention are the high tensile strength and the flexibility, so it is easy to direct the eight strands (16) to slip through the steel pipe holes (17) of upper column (2). The rugged surface of the strand (16) helps to increase the adherence between the mortar (18) and the strand (16). The steel strand of a relatively short length in this invention, is easily acquired as a waste from the high tensile steel strand usage in the prestress pretension concrete industry. FIG. 5 and 7 show the construction detail and the connection with the slab corners (3). Steel rods (4) and (6) that are welded to the steel pipe (20) at a point (23) with the steel rods (4) and (6) of approximately 100 cm in length function as anchors for the steel pipe (20) of the concrete slab (3). Several pairs of straight steel rods (5) are welded at uniform distances connecting the two steel anchors (4) and (6) to serve two functions: as a steel reinforcement to receive shear force, especially around the slab corner or around the steel pipe (20), and as a link for reinforcement (4) and (6) to become one construction frame that works together and as a strengthening reinforcement system in critical spots at corners where the load can come from external forces such as an earthquake, with a changing load direction. On the steel pipe wall (20) and between steel anchors (4) and (6), there are holes (30). The holes (30) enable steel rods (29) to cross steel pipe (20) from the peripheral beams of the slab and to function as prestress pretension reinforcement on the said beams.

FIG. 7 shows four slab corners (3) on column (1). It also shows a connection between the steel pipes (20) of the slabs (3) which are tied together by three high tensile wire ropes (31) that are slipped through pre-bored holes (13), (14), (15) on the pipe wall (20). The three wire ropes (31), (31a), and (31b), are also shown in FIG. 6b. The passage of the steel pipe (21), the gaps between pipes (27) on the lower column (1), and the gaps between the slabs (25) are filled with special mortar. Observing FIGS. 6a and 6b, the flow of

Appendix 3. Demountable building partition construction

April 16, 1968

H. M. POLHAMUS

3,377,756

DEMOUNTABLE BUILDING PARTITION CONSTRUCTION

Filed Oct. 22, 1964

2 Sheets-Sheet 1

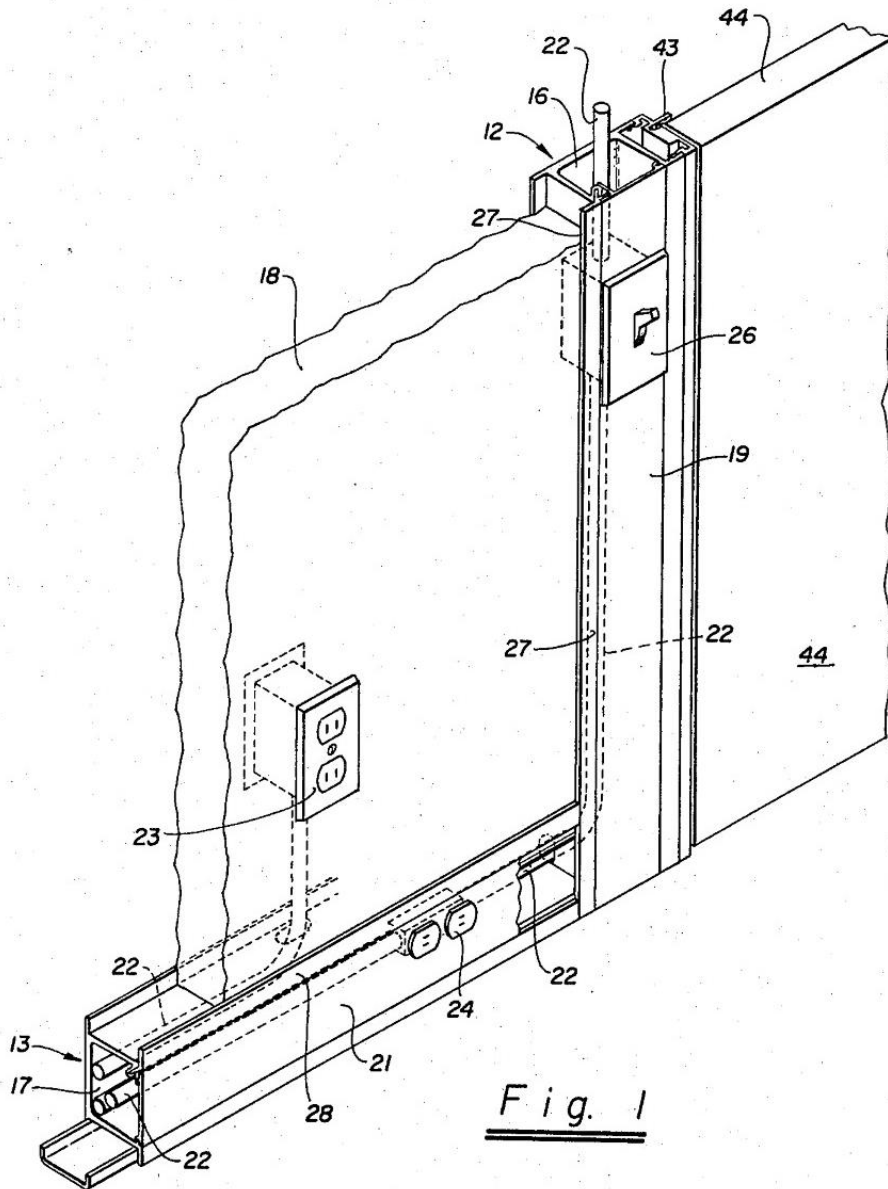

Fig. 1

INVENTOR.
Harry M. Polhamus
BY
Manfred M. Warren
His Attorney

April 16, 1968

H. M. POLHAMUS

3,377,756

DEMOUNTABLE BUILDING PARTITION CONSTRUCTION

Filed Oct. 22, 1964

2 Sheets-Sheet 2

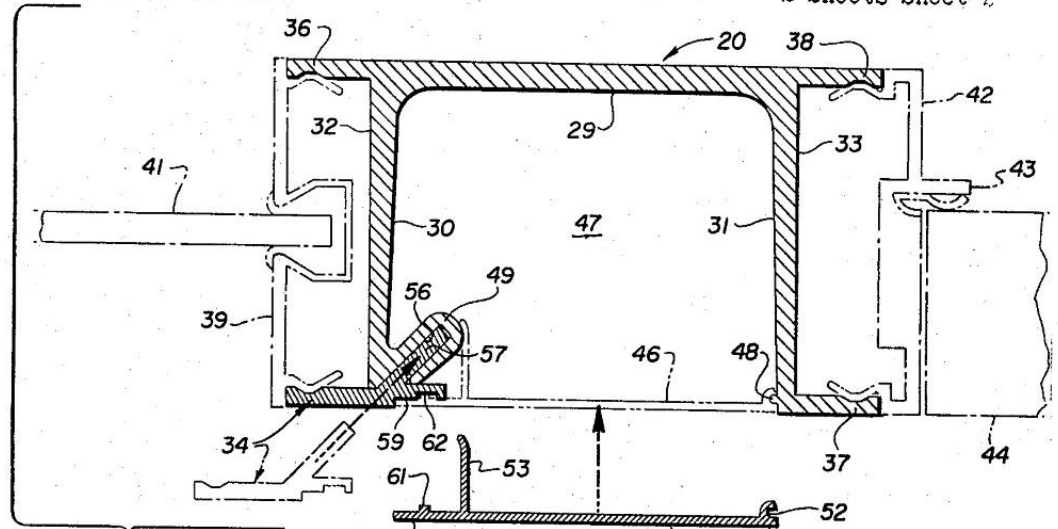

Fig. 3

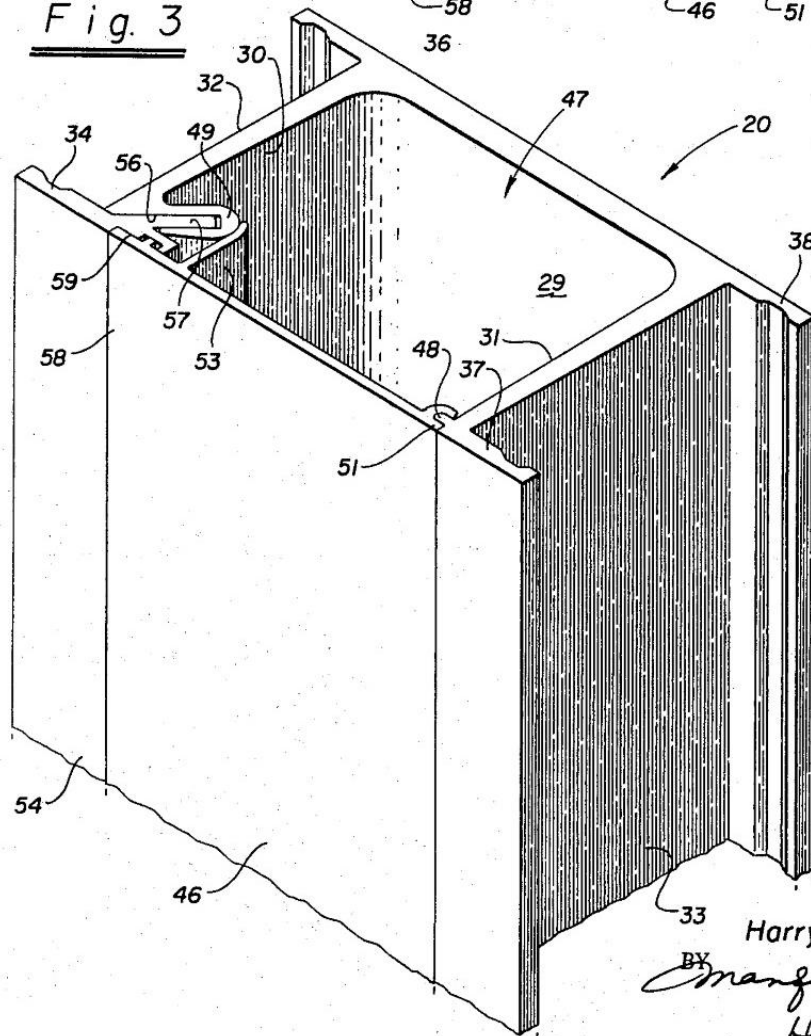

Fig. 2

INVENTOR.
 Harry M. Polhamus
 BY *Manfred H. Haven*
 His Attorney

1

3,377,756

DEMOUNTABLE BUILDING PARTITION CONSTRUCTION

Harry M. Polhamus, Orinda, Calif., assignor to Movable Interior Products, a corporation of California
 Filed Oct. 22, 1964, Ser. No. 405,807
 3 Claims. (Cl. 52-220)

This invention relates generally to the art of building construction, and more particularly to the construction of interior partition structures including solid panels, doors, glass panels, and the like.

In modern office buildings and similar structures, there is a frequent need to rearrange and improvise floor plans and room designs to accommodate the particular requirements of different building tenants. This accommodation often involves moving interior walls, substituting different types of partition panels, doors, etc., for existing structures, and modifying electrical wiring or other utility services.

A difficulty often encountered in providing movable or demountable partition structures is that there is limited service access for electrical wiring, telephone connections or the like. Consequently, electrical wiring conduit and similar provisions must be installed at the time the building partition is being constructed, and cannot be easily modified or serviced after the structure is completed. Another difficulty sometimes presented is in the substitution of one type of partition member for another, which may require extensive dismantling of otherwise unaffected adjacent partition members. For example, if a glass panel or a door is to be substituted for an existing solid panel, it may be necessary to substantially disassemble the partition structures adjacent either side of the solid panel being replaced.

Accordingly, one object of the present invention is to provide a building partition construction in which electrical wiring and the like can be installed at any time during or after the assembly of a wall partition structure, and can be readily serviced or changed without disassembling or otherwise modifying the existing wall structure.

Another object of the invention is to provide a building partition construction in which various partition members can be readily replaced or rearranged without disassembling adjacent unchanged portions of the partition construction.

A further object of the invention is to provide a building partition structural support member that houses electrical wiring or similar utility conduit and retains various types of partition members such as solid panels, glass, doors, etc., and which enables installation or modification of such conduit and replacement of such partition members without disassembly or modification of otherwise unchanged portion of the partition construction.

Still another object of the invention is to provide a structural support member as described above that utilizes a removable retaining portion and a removable cover portion, and which provides secure retention of such removable portions without threaded fasteners or other separate fastening devices.

The invention possesses other objects and features of advantage, some of which of the foregoing will be set forth in the following description of the preferred form of the invention which is illustrated in the drawings accompanying and forming part of this specification. It is to be understood however, that variations in the showing made by said drawings and description may be adopted within the scope of the invention as set forth in the claims.

Referring to said drawings:

2

FIGURE 1 is a fragmentary perspective view of a building partition construction comprising a preferred embodiment of the present invention.

FIGURE 2 is a fragmentary perspective view of a support member utilized in the structure shown in FIGURE 1.

FIGURE 3 is a partially exploded transverse cross-sectional view of the member shown in FIGURE 2.

A building partition construction comprising a preferred embodiment of the invention is illustrated in FIGURE 1, and is seen to include a vertical support member 12, a horizontal support member 13 having an end 14 disposed adjacent the vertical member 12, the members 12 and 13 each respectively having elongated raceways 16 and 17 for housing utility conduits, a solid panel partition member 18 retained by each of the support members, the members 12 and 13 each respectively including selectively removal cover portions 19 and 21 for providing access to the raceways 16 and 17, the cover portions being removable from their respective support members without movement of the partition member 18. The aforesaid utility conduit as shown consists of electrical wiring conduit 22 which extends through the raceways 16 and 17 and connects with outlet sockets 23 and 24 and a switch 26.

Each of the support members 12 and 13 further includes a removable retaining portion 27 and 28 for securing the panel member 18 in place. As will be described more fully hereinafter, the cover portions 19 and 21 respectively engage the retaining portions 27 and 28 with the latter being removable only when the corresponding cover portion is removed. The cover portions, however, are removable while the retaining portions remain in position securing the panel member. It thus will be seen that the electrical conduit 22 can be installed or serviced after the panel 18 is secured in place simply by removing the cover portions to provide access to the raceways. The panel 18 can be removed from the support members by removing the retaining portions 27 and 28 after the corresponding cover portions are removed.

Support member 12 and 13 are of identical construction and are formed to accommodate a variety of partition arrangements as illustrated in the drawings. The detailed description of these main support members with reference to a typical member 20 illustrated in the enlarged views FIGURES 2 and 3 will accordingly suffice for a description of members 12 and 13. As will be observed from FIGURES 2 and 3, the support member 20 is of generally elongated channel shape having a central wall portion 29 and a pair of spaced side walls 30 and 31 extending perpendicularly from wall 29 internally from opposite side edges 36 and 38 which project as flanges perpendicularly from the side walls 30 and 31. These flanges cooperate with flanges 34 and 37 at the outer extremities of side walls 30 and 31, for retaining wall partition members extending away from the channel member 20. In FIGURE 1 a partition panel 18 is shown as being retained by similar spaced flanges on members 12 and 13. A snap-in bracket 39 is shown in FIGURE 3 removably secured between the flanges 34 and 36, and is adapted to retain a glass panel 41 or similar member. Another snap-in bracket 42 is secured between opposed flanges 37 and 38, and includes a portion of 43 that forms a door jamb for a door 44. A similar door and door jamb are illustrated in FIGURE 1 adjacent the vertical support member 12.

An elongated front wall cover portion 46 is removably secured across the outer ends of the side walls 30 and 31 in spaced relation with central portion 29 to define a service raceway 47 within the channel mem-

ber 20. The cover portion 46 is removable from the side wall portions independently of the spaced flange retaining means. In the preferred form of the invention as shown in FIGURES 2 and 3, the removable cover portion 46 is secured in place by means of an elongated ridge 48 provided longitudinally on the said wall 31 in confronting relation with the side wall 30 and an elongated ridge or boss 49 provided longitudinally on the side wall 30 in confronting relation with ridge 48. The edge 51 of the cover portion 46 has an elongated groove 52 therein that is engageable with the ridge 48, and an elongated flexible resilient flange or clasp 53 extends inwardly from the cover portion 46 for engagement with the boss 49. To insert the cover 46, the groove 52 is first engaged with the ridge 48, and the cover 46 is then pivoted about the axis of the ridge 48 until the flange 53 resiliently engages the ridge 49 and snaps into locking engagement therewith.

In accordance with the present invention and as an important feature thereof, flange 34 is provided by a separate slide-out member removably retained in position on the outer end of wall 30 by the front wall 46 when the latter is in closed position; and the flange member 34 may be removed as desired to repair or replace the partition member retained thereby only after the front wall member 46 is removed. The slide-out flange member 34 corresponds with the removable retaining portions 27 and 28 described in connection with the showing in FIGURE 1. As will be best seen in FIGURES 2 and 3, boss 49 is formed with a longitudinally extending diagonally outwardly opening slot 55; and flange member 34 is formed with a tongue 57 slidably mounted in slot 56 and arranged so that with the tongue retained in the slot, flange 34 will project perpendicularly from wall 30 in parallel opposed relation to flange 36 for retaining partition members, brackets, and the like of the type above described. An end portion 58 of cover 46 overlies and engages a portion of the flange member 34 outside of the tongue 57 so as to prevent the sliding out of the tongue from its engaged position in slot 56. As here shown, member 34 is formed with a recess 59 which received the edge portion 58 with the outer surfaces of the members substantially flush and neat fitting as seen in FIGURE 2. Also the slide out member 34 is prevented from being separated from the main channel member 20 by means of an internal ridge or shoulder 61 formed on the cover plate member 46 at the edge portion 58 and which is received within an interlocking groove 62 provided in recess 59.

As will be observed from the foregoing the cover 46 can be removed to provide access to the raceway 47 while the flange member 34 is left undisturbed in its support of the partition holding bracket 42. In the event it becomes necessary or desirable to repair or replace a particular partition member being secured to the flange member 34, the latter is simply removed by sliding the tongue 57 out of the slot 56. The parts may then be reassembled by repositioning the flange member 34 as illustrated in FIGURE 3 and then snapping the cover member 46. Preferably and as here shown, tongue 57 extends from the plane of flange member 34 at about 45 degrees and slot 56 is formed in boss 49 so as to open out diagonally at about 45 degrees with respect to wall 30 and front cover member 46. Accordingly to insert or remove flange 34 as depicted in FIGURE 3, the flange member is required to move diagonally with respect to wall 30 and cover member 46 as illustrated.

In the preferred form of the invention the channel member 27, the retaining portion 54, and the cover portion

46 are all constructed from extruded aluminum. It will be appreciated that aluminum has sufficient flexibility and resiliency to enable the flange 53 to engage the ridge 49 for selective snap-in positioning and removal of the cover portion 46.

In view of the foregoing it is seen that the present invention provides an improved and versatile building partition construction that affords the various objects and features described hereinabove.

I claim:

1. In a building partition construction, the combination comprising:

an elongate channel having a central wall and first and second spaced side walls extending therefrom at substantially right angles thereto, said side walls being located inwardly from the proximate side edges of said central wall, the first of said side walls having a boss formed at the free end thereof, said boss having a slot formed therein angularly disposed in respect to said central wall at an angle of less than 90° and extending longitudinally thereof;

a detachable flange including a tongue portion adapted to slidably mount into said slot for support by said boss wherein that portion of the detachable flange not entering said slot is disposed parallel to said central wall with the angle of said tongue portion relative to said central wall selected to cause the tongue to bind within the slot and remain secured in the event of movement of said detachable flange along a line normal to the central wall;

an elongate cover plate shaped to form a closure for said channel between said side walls and define a service raceway within the bosom of the channel; and means associated with said cover plate and said side walls for demountably securing the cover plate to the free edge of the second of said side walls and to said boss, said cover plate having one edge away from the second side wall overlapping and engaging a portion of said detachable flange so as to retain the latter when said tongue is engaged in said slot, said cover plate being moveable from the closure position without movement of said detachable flange and the latter being removable when said cover plate is disengaged from overlapping the flange.

2. In a building partition construction, the combination as claimed in claim 1 and wherein further said slot is angularly disposed in respect to said central wall at an angle of 45°.

3. In a building partition construction, the combination as defined in claim 1 and wherein further said means includes means hingedly securing one edge of said cover plate to the free edge of said second side wall, and a clasp carried by the front wall of said cover plate adjacent the one edge thereof proximate said boss and formed for detachable engagement with the boss.

References Cited

UNITED STATES PATENTS

3,016,993	1/1962	Owen	52—502 X
3,160,244	12/1964	Kushner	52—221 X
3,195,698	7/1965	Codrea	52—221 X
3,212,225	10/1965	Neal	52—501 X
3,221,453	12/1965	Lietaert	52—209

FRANK L. ABBOTT, *Primary Examiner.*

M. O. WARNECKE, R. A. STENZEL,

Assistant Examiners.