

Zipporah Tarus

PIR Sensor-based Security System

Helsinki Metropolia University of Applied Sciences

Bachelor of Engineering

Degree in Electronics

Thesis

Date 21.12.2017

Author(s) Title	Zipporah Tarus PIR Sensor Based Security System
Number of Pages Date	38 pages + 2 appendices 20.12.2017
Degree	Bachelor of Engineering
Degree Programme	Electronics
Specialisation option	
Instructor(s)	Matti Fitcher, Principal Lecturer
<p>This thesis deals with the design and implementation of a PIR sensor-based home security system which uses Raspberry pi and PIR sensor. The project is designed to assure home security through surveillance.</p> <p>The project is based on PIR sensor connected to an integrated circuit for the generation of an alarm. HDMI transmits pictures and videos to a displaying screen which saves this information and sends an alert to a specified mail recipient. Raspberry pi is responsible for the operation and control of motion. Detectors and video cameras, on the other hand, sense movement and give surveillance and stream live video or record occurrences for later playback. The sensor perceives Infrared Radiations (IR) emitted from humans within their field of view then provides a digital output. The output is applied to the UM3561 IC generating sound upon detection of human intrusion.</p> <p>The design also will provide the number of persons located, with the help of a Passive Infrared sensor. When PIR Sensor detects motion, the camera automatically initiates recording and Raspberry pi device alerts the owner of a possible intrusion having a display on the screen and sending an email alert to a specified email address. The circuitry is inexpensive, and its electronic security system is highly secure</p>	
Keywords	Raspberry pi, PIR sensor

Contents

1 Introduction	4
2 Literature Review	6
2.1 Security Cameras	6
2.1.1 Indoor Security Camera	6
2.1.2 Outdoor Security Camera	8
2.2 Sensors	10
2.2.1 Glass Break Sensors/Detectors	10
2.2.2 Window and Door Sensors	11
2.2.3 Smoke Detectors	12
2.2.4 Motion Sensors	12
2.2.5 Environmental Sensors	14
2.3 Raspberry Pi	15
2.3.1 Memory	16
2.3.2 Ethernet port	16
2.3.3 CPU	16
2.3.4 GPU	17
2.3.5 Display	17
2.3.6 GPIO	17
2.3.7 UART	18
2.3.8 XBee Socket	18
3. Project Design and Implementation	19
3.1 PIR Sensor	19
3.2 Pi Camera	22
3.3 Raspberry pi 3	23
3.4 Raspbian OS	26
3.5 SD Card	27
3.6 Project Software	28
3.6.1 Configuring Virtual Network Computing VNC	28
4. Results and Discussion	29
4.1 Results	29
4.1.1 Human Detection	29

4.1.2 Image Capture and Video Recording	29
4.1.3 Email Notification	30
4.2 Discussion	31
5. Conclusions and Recommendation	33
5.1 Conclusions	33
5.2 Recommendations	33
References	35
Appendices	38
Appendix1: PIR Code	38

List of Figures

Figure 1: Glass break Detectors	10
Figure 2: Door/window detectors	11
Figure 3: Smoke Detectors	12
Figure 4: PIR Motion Sensors	13
Figure 5: Frensel Lens	13
Figure 6: Functional Block Schematic of Raspberry Pi	15
Figure 7: Model B raspberry pi hardware	17
Figure 8: System Block Diagram	19
Figure 9: PIR Sensor Operation	20
Figure 10: Passive Infrared Sensor	20
Figure11 : PIR Sensor	21
Figure 12: PIR Pin Configuration	21
Figure 13: Pi Camera	23
Figure 14: Raspberry Pi 3 Hardware	23
Figure 15: System flow diagram	24
Figure16: Program Cycle	25
Figure 17: Image Capture	29
Figure 18: Video Preview	30
Figure 19: Email Notification	31

List of Tables

Table 1: Indoor Home Security Cameras.	7
Table 2: Outdoor Security Cameras	9

1 Introduction

Surveillance, from homes to huge industries, plays a significant role in the fulfilment of our security. Aspects such as burglary and theft have always been a predicament. In large industries, personal safety refers to the monitoring of the people's shifting information like activities and behaviour to protect, manage, and influence personal details. Surveillance refers to observing over from a distance by use of electronic equipment like CCTV cameras. However, CCTV technology is expensive for average residents to install. Additionally, this kind of system does not notify the user immediately a burglary occurs. This thesis paper includes an alarm system to overcome the shortcomings of the regular surveillance systems.

In Kenya, for example, this system can work best due to its lower consumption of power especially in remote places where electricity is a challenge. The use of a machine to machine communication offers benefits when compared to the traditional Data Acquisition System (DAS). The system allows monitoring and control to be done without human intervention [1, 1]. The system becomes fully automatic, and the amount of error decreases with its efficiency increasing drastically.

Individuals should have the choice to live without fear and the confidence to carry out any business without fear of insecurity. The system created in this study offers security while maintaining the privacy of individuals since only one person can view it. Additionally, it uses a simple circuit. The system uses Raspbian OS for its operations, allowing the transmission of images to a smartphone [2, 7107]. The traditional surveillance system is associated with various challenges and costs associated with energy use. An energy effective moveable system is preferable, and it can capture images during an occurrence of burglary. The system, therefore, allows people be more independent and feel secure in their everyday activities. Further, it sends out an alert signal, making it better than the currently used surveillance systems.

Project implementation is simple. The homeowner/ company place a camera in a particular area that needs monitoring to ensure security. The system allows the user to access and monitor security from different locations, even remote areas. The user can monitor the remote surveillance system using a smartphone with connected internet availability. The system is useful for projects targeting security setups limited to a specific location, but whose security is monitored from separate locations.

The primary objective of this study is:

- ❖ To create a security-based system which is more affordable and flexible as far as location is a concern

And the specific goals are;

- a. To design a simple, cost-effective and easy to implement PIR security-based system using the existing technology.
- b. To design PIR security-based system for persons who might want to control their work, office, or home from a distance.
- c. To fabricate PIR security-based system.

The system is small in size, portable, and stand-alone with its power source making it simple to implement. It also possesses energy for instant alert and is cost-effective for both residential and personal use.

2 Literature Review

2.1 Security Cameras





Security cameras are of many types with apparently many feature preferences. Deciding on the camera for use in a home-setting can be a daunting task given the numerous options. Although these cameras are available in a wide range of sizes, fields of view, the quality of images, and different ranges of motion, security cameras used in homes all provide video images of occurrences within a field of view. The cameras can display the actions taking place in real time or record everything for later view. Some of the camera systems enable users to observe and control their security cameras online.

Security cameras are categorized into those used indoors and outdoors. Each of the categories has different camera styles. Further differentiation, by and large, is not necessary because the variation is apparent during the evaluation of features. Security cameras can either come as stand-alone units with installed apps for monitoring the system or as part of a package which users subscribe to for provision of home security [3,8].

2.1.1 Indoor Home Security Cameras

Cameras used in indoor settings are the foundation of an efficient home security system. The following table 1 lists of each of these cameras with corresponding resolution, pros, and cons.

Table1. Indoor Home Security Cameras.

Camera type	Resolution	Pros	Cons
 Vimtag VT-361 PTZ Cloud Camera	720p	<ul style="list-style-type: none"> ✓ It has 120° pan and can tilt at 320° ✓ It possesses a Mic and a speaker to enable 2-way Talkback ✓ Affordable cost 	<ul style="list-style-type: none"> ✓ The static field of view is not known
 Nest Cam Indoor	1080p	<ul style="list-style-type: none"> ✓ The camera has a good resolution for clarity of images ✓ It has a Mic and speaker to enable the 2-way talkback ✓ Huge field of view 130°. 	<ul style="list-style-type: none"> ✓ The camera is costly ✓ The night-vision distance of the camera is unknown. ✓ No movement
 Arlo Wire- Free VMS 3130	720 p	<ul style="list-style-type: none"> ✓ Ability to be used outdoors. ✓ It has a night vision range of 25 feet. ✓ Its field of view is at 110°, enabling a wider view. 	<ul style="list-style-type: none"> ✓ No sound capabilities. ✓ High prices
 Amcrest	1080 p	<ul style="list-style-type: none"> ✓ The camera type has an improved night vision in the range of 32 feet. ✓ It has a speaker and a Mic to enable the 2-way talkback. 	<ul style="list-style-type: none"> ✓ The camera is costly to the user.

The cameras in the table 1 above possess Wi-Fi abilities and allow online monitoring by use of a smartphone using the camera's matching app.





2.1.2 Outdoor Home Security Cameras

The outdoor security cameras are referred to as multi-camera surveillance systems. They monitor any out-of-doors area one chooses and are available as either wired or wireless. Typical placements include walkways, entrances, and driveways.

Outside cameras are purposely designed with a broader viewing angle to watch over large outdoor areas. Majority of these devices come with night vision to capture video and images during the dark. The cameras are designed to be weather resistant with durable protective housing to shelter the electronics from moisture and rain.

The best stand-alone outdoor cameras are listed in the table below, each with resolution, pros and cons.

Table 2. Outdoor Security Cameras

 Amcrest Qcam	1536p	<ul style="list-style-type: none"> ✓ Good night vision range of 65 feet. ✓ Great resolution. 	<ul style="list-style-type: none"> ✓ No movement capability. ✓ No Wi-Fi capability. ✓ No sound capabilities
 ZOSI 960H	900 tvl	<ul style="list-style-type: none"> ✓ Low price ✓ Good field of vision at 72°. ✓ Great range of night vision at 20 feet. 	<ul style="list-style-type: none"> ✓ Has no movement capability ✓ Does not have Wi-Fi. ✓ No sound capabilities.
 Uniden GC45S	1080p	<ul style="list-style-type: none"> ✓ Has and a speaker for 2-way talk-back ✓ Pan and tilt capabilities. ✓ Good resolution. 	<ul style="list-style-type: none"> ✓ Requires purchase of full system ✓ Has a low night vision. The range of 40 feet.
 Phylink Bullet HD	1080p	<ul style="list-style-type: none"> ✓ Great field of vision of 90°. ✓ Built-in Mic. ✓ Good resolution. 	<ul style="list-style-type: none"> ✓ No zoom ✓ High price ✓ Low night vision of 30° feet

The cameras in table 2 above are wall-mounted and can be monitored through online applications.

2.2 Sensors

A sensor is an electronic device which detects and responds to an optical or electrical signal. Sensors convert input from physical parameters, e.g. humidity, temperature, light, heat, motion, and other measured environmental phenomena to an electrical signal. The electrical signal is converted to a human-readable interface and displayed in computer monitors for reading, interpretation, and processing [4,1].

Sensors provide a whole-house protection entirely. Improvement in technology as regards modern security has enabled users of security systems to monitor and view alerts via their smartphones when sensors are triggered. Technology has increased the effectiveness of the security systems and reduced the time taken in response to security breaches. The common security sensors used include the environmental sensors, smoke, glass-break sensors, door/window sensors which have been useful in enhancing the effectiveness of the security system.

2.2.1 Glass Break Detectors/Sensors

Glass break sensor is used in electronic burglar alarms and detects if a piece of glass is shattered or broken. The sensor works by monitoring vibration and sound thus complimenting the door/window sensors. When glass shatters; the sensor detects the frequency or shock waves and sounds an alarm. Glass break detectors remain armed at all times and enhance the efficiency of the security systems.

The glass sensors are ideal for rooms with sliding doors and large windows. The limited range associated with the detectors requires a homeowner to fix multiple glass-break sensors to enhance efficiency. Illustrated in fig 1 are glass Break detectors.



Fig 1. Glass Break Detectors[wikipedia].

They are two types of glass break sensors, the acoustic and the shock sensors. Acoustic sensors are designed to detect the exact sound waves of breaking glass while shock sensors detect vibrations when glass breaks. Shock sensors are likely to trigger false alarms as a result of slamming doors which could have similar vibrations as breaking glass. To overcome these limitations, a homeowner should opt for glass break detectors that rely on acoustic sensors which are fitted with small microphones capable of detecting specific frequencies associated with breaking a glass [5,13].

2.2.2 Window and Door Sensors

Home security systems are ensured by the defence employed on secure windows and doors. Most burglaries reported annually are a break-in on residential homes as a result of entry through doors and windows. Security of a home is guaranteed by installing door and window sensors to prevent entry and potential danger.

These sensors are placed on the doors and windows of buildings. When the door or window is breached, the sensor transmits a signal to the central control system triggering an alarm. Window or door sensors are easy to set up since no wiring is required. [6,7]. Their operating range is up to 150 feet away from the Choice Alert Wireless Control Centre and has long-lasting, weather-resistant design.

Below in fig 2 are a few images of window and door sensors.



Fig 2. Door/window detectors [26].

Window/door sensors come in twofold. One fits onto the door/ window while the other is attached to the frame and kept in place by adhesives or screwed to the door or the window frame. The two pieces of sensors are placed near each other so that when they are separated, for example through the opening of the door, it triggers an alarm.

2.2.3 Smoke Detectors

Smoke detectors are devices that sense smoke, a common indicator of fire. These devices sense combustion of gases like carbon dioxide and carbon monoxide. Smoke detectors for homes, also called smoke alarms, issue a visual or an audible alarm [7,783]. They reduce the risks associated with dying in a home fire.

Fig 3 illustrates various smoke detector designs.



Fig 3. Smoke detectors [wikipedia].

The detectors are housed in disc-like plastic enclosures. They enable the detection of smoke through either ionization or optically.

2.2.4 Motion Sensors

Motion sensors use infrared sound and vibration to detect moving objects or people. The sensors gather data as regards the acceleration, velocity, and position of the object. When motion sensors are attached to a home security system, they can detect motion alerting the homeowner of any breach of security.

Motion sensors use one or several technologies to sense movement in an area. The use of multiple technologies, microwave technology and passive infrared sensor (PIR) technology, helps to reduce the possibility of false alarms and increase the efficiency of the surveillance security system. The sensors are sensitive to an individual's skin temperature and are designed to use mid-infrared wavelengths in the detection of movements [8, 8].



Fig 4. PIR Motion Sensors [31].

PIR sensor is one example which constitutes detectors of motion. A combination of Fresnel lens, amplifier circuitry, comparator, and time delayer circuitry forms the basic structure of PID (Passive Infrared Device), PIR sensor being the critical component.

Fresnel lens is a special filter which focuses infrared signals onto the component. It consists of a number of concentric grooves that changes the direction of light. The lens is designed to collect energy, focus and disperse light, and collimation. Fig 5 below illustrates a Fresnel lens.

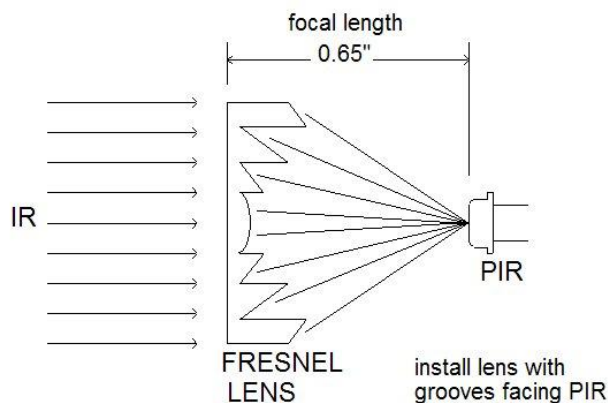

Fig 5. Fresnel lens [28].

Fresnel lens captures infrared (IR) radiation and concentrates it to a small point. The central point moves the sensor transversely as IR source move and exposes one element at a time. The detection range of Fresnel lens can extend up to about 100 feet. It is useful for applications such as imaging, lighting and PIR sensors

The following are features of Fresnel lens;

- Designed for wavelengths of between 5 and 20 microns
- Maximum transmission of 9 to 12 microns
- The refracting surface at the outer part of the lens is compacted to a flat plane
- Low profile sensors are depicted by reduced focal lengths
- Use of Reflexite's proprietary design software for Optical Surfaces.

The main user of (PIR) Fresnel lens is the security industry. The sensor's array, when combined with a pyroelectric detector generates a functional detection pattern. Apart from its use in security, the lens array is also applicable in:

- Lighting control systems
- Environmental control systems
- Burglar alarm / Security
- Motions activated lighting

Non-PIR applications are; noncontact thermometers and thermal imaging with low resolution.

Fresnel lens is designed for white light exemption and even sensitivity from any angle. They are cheap and easy to use.

2.2.5 Environmental Sensors

An environmental sensor is a device used for measuring or detecting key environmental parameters like temperature, humidity, gas, moisture, or other environmental content. These sensors then provide a comprehensive and consistent data which is converted to analogue or digital representation. Environmental sensors alert one of any moisture in a home as a result of flooding, burst pipes, leaks, and extreme temperatures in places like kitchens and bathrooms, laundry rooms and basements.[10, 40].The sensors can also detect elevated levels of carbon monoxide gas enabling homeowners to take the necessary precautions.

Environmental sensors are installed in leak-prone areas of the home, for example, under sinks and behind water heaters to minimize damages associated with dangerous conditions. Environmental monitoring applies to specific conditions in a home security system. The system combines and tracks measurements of both internal and external parameters [11, 12].

Some examples of environmental sensors include ceilometer, gas detector, hygrometer, soil moisture sensor, and tide gauge among others.

2.3 Raspberry Pi

Raspberry Pi is a computer, the size of a credit card, which was designed to promote the training on computer programming skills and the understanding of computer hardware in schools. Due to its size and accessibility in price, it was adopted by users for projects that required more than a primary microcontroller. Raspberry pi has computer capabilities. It plugs into a TV or a keyboard and is used in electronics projects and desktop PC for spreadsheets, browsing the internet, playing games, and word processing. Raspberry Pi comes with a free operating system called Raspbian which is a version of Debian and is optimized for the hardware components of the system [12, 53]. The system is capable of running wireless home speakers, a media centre for TVs, and personal web servers. It is a low-cost portable miniature computer which can play high-definition video.

Shown in figure 6 below is a functional block schematic of Raspberry Pi. It utilizes 5V DC.

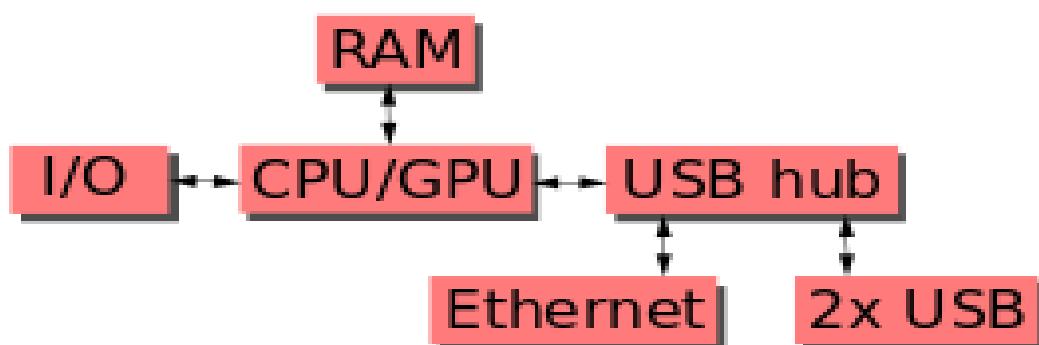

Figure 6. Functional Block Schematic of Raspberry Pi

Raspberry pi board contains Random Access Memory (RAM), Central Processing Unit (CPU)/ Graphics Processing Unit (GPU). Additionally, it includes a port for Ethernet connection, XBee socket, UART, GPIO pins and a connector to the power source. The critical hardware specifications for raspberry pi include keyboard, monitor, SD card containing Linux Operating Systems, video cable and power supply. Other hardware devices that may be used include internet connection, USB mouse, case, and powered USB hub. Raspberry Pi comes in various models, i.e. Raspberry Pi 3, Raspberry Pi 2, Raspberry Pi Zero and Raspberry Pi 1.

2.3.1 Memory

Raspberry Pi is small in size compared to Personal Computers. Whereas memory for PC is in gigabytes, the raspberry pi board is designed with 256MB of SDRAM for model A and 512MB for model B.

2.3.2 Ethernet port

Ethernet port is the primary gateway enabling communication with other devices. It is used for internet access by plugging the home router. During the setting up of raspberry pi, however, a connection to the internet is not needed.

2.3.3 CPU

The Central Processing Unit (CPU) is the brain of a raspberry pi board where all mathematical logic computations take place. It carries out instructions for receiving input, doing calculations and producing output. It is also referred to as central processor and uses an ARM11 series processor.

Model B raspberry pi hardware is as shown in fig 7.

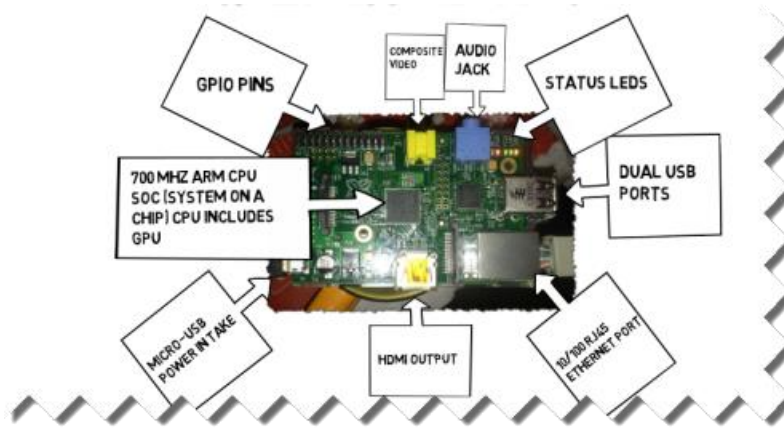

Figure 7. Model B raspberry pi hardware [30].

2.3.4 GPU

Graphics Processing Unit (GPU), also known as a graphics processor is similar to computer's CPU. It is designed purposely for performing complex mathematical and geometric calculations that are essential for graphics rendering. GPU handles graphics operations at an accelerated rate. It is usually located under a heat sink or a fan to reduce the so much heat generated by GPU.

2.3.5 Display

Raspberry pi board allows connections via Composite or HDMI types. HD TV monitors and many LCDs are connected by use of an HDMI male cable in addition to a low-cost adapter. Older TVs can be connected using composite videos.

The output of the system may be in the form of pictures, audio or video files requiring an attachment of an HDMI cable to the monitor.

The HDMI port of raspberry allows an output of data; either video or audio, but does not support input data.

2.3.6 General Purpose Input and Output (GPIO) Pins

The GPIO pins are useful in associating raspberry pi to other electronic boards and components. The pins accept the input and output commands as per the programming of raspberry pi. In surveillance, the pins can be connected to motion sensors to enable transmission of digital data [13, 5.]

2.3.7 UART

The Universal Asynchronous Receiver/ Transmitter is a serial input & output port commonly used on the Pi as an appropriate way to control it over the GPIO. It takes bytes of data and sequentially transmits individual bits and can be used to transfer serial data in the form of text [14, 13]. UART is useful for conversion of the debugging code.

2.3.8 XBee Socket

XBee socket is used in a raspberry pi board for wireless communication purpose.

3. Project Design and Implementation

The development target is to have a low-cost security system for home applications. The system uses small PIR (Pyroelectric Infrared) sensor built around a microcontroller. The microcontroller senses human motion by detecting infrared radiations from a human body.

Figure 8 below shows the block diagram; Source of power must be reliable

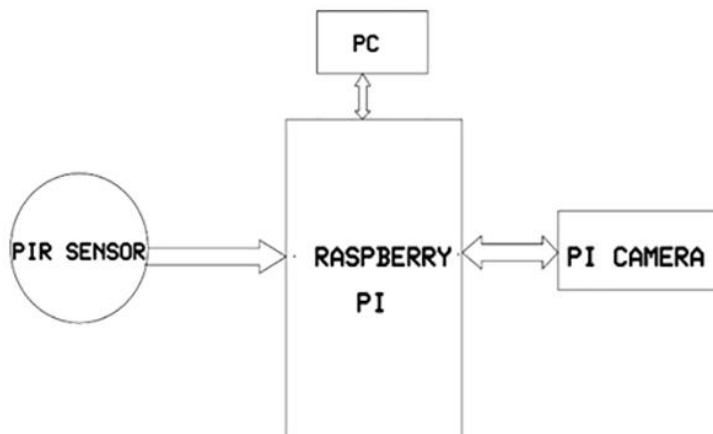

Figure 8. System Block Diagram

The home security system uses wires to make connections between the central controller and devices necessary for surveillance and home security. These devices include the cameras, sensors, video displays, keypads, motion detectors, camera switches and speakers [15, 34].

The system is composed of the hardware and the software parts; where both parts are interfaced to work together in response to the PIR sensor. The hardware part of the system consists of the PIR sensor, being the main component, amplifier, power supply, window detection circuit and a computer. The software portion is made up of the algorithms that make the various parts operational

3.1 PIR Sensor

Passive Infrared (PIR) sensor is the foundation of the security system. The sensor's functionality is based on infrared radiations emitted from the human body. It is a useful

tool for detection of human movement as it detects a change in infrared radiations as a result of moving warm-blooded objects within their range. All objects, including human beings, produce electromagnetic radiations. The wavelengths of these radiations are dependent on the temperature of objects. Human beings emit infrared radiation with wavelengths ranging between 0.7 and 300 micrometres [16, 29]. On the other hand, normal body temperature of human beings radiates IR at wavelengths of 10 micrometres to 12 micrometres. PIR sensors, passive electronic devices; detect motion by sensing the fluctuations of infrared radiations.

Figure 9 below shows how the sensor detects human movements.

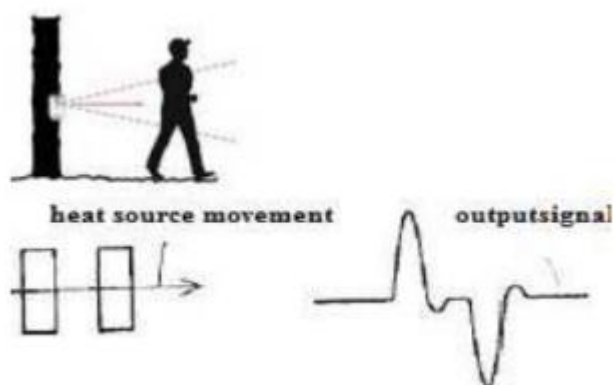

Figure 9. PIR Sensor Operation [25].

PIR sensor plays a passive role in the detection of infrared radiations i.e., it does not emit any emissions itself. Instead, the sensor passively detects infrared radiation emitted by human body within its range [17, 15.]

Fig 10 below gives an overview of how radiations and detection of motion occur.

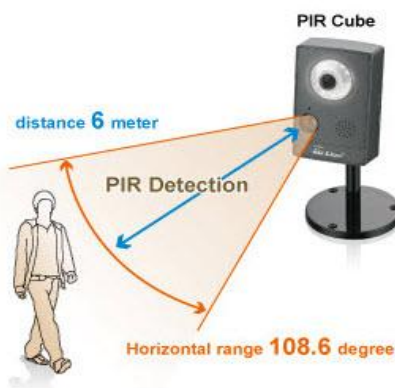

Figure 10. Passive Infrared Sensor [27].

PIR Sensor is pyroelectric device sensitive to moving objects radiating IR. Any changes in infrared radiation within the field of the sensor result in the creation of temporary electric potential. The potential generated, however, is very small in amplitude and is, therefore, necessary to be amplified considerably. This explains why a PIR sensor cannot be used alone but in connection with other components of home surveillance systems. The sensor is an important component of Passive Infrared Devices (PID) when combined with other circuitry [18, 2]. The device has three pins (gate, drain and source).

The image below shows a PIR sensor, and its typical pin configuration which is quite simple to understand the pin-outs



Fig 11. PIR Sensor [27].

The PIR pin configuration is as in fig 12 below.

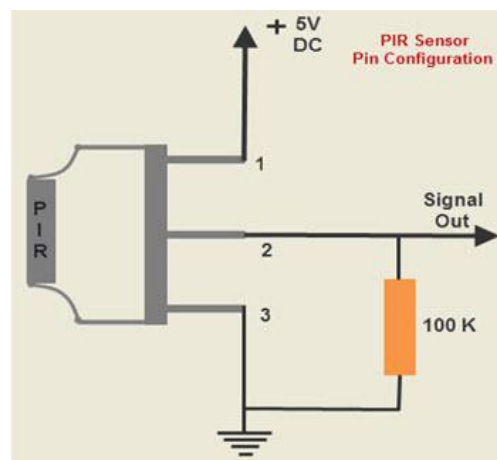

Figure 12. PIR Pin Configuration [27].

The PIR sensors consist of three pins and a functional description of each of these pins is as described hereunder:

- Pin1 correlates with the drain terminal of the device and is connected to the positive supply of 5V DC.
- Pin2 correlates with the device's source terminal, and should be connected to the ground terminal using a 47K or a 100K resistor. The pin is the sensor's output pin and it carries the Infrared signal detected to the amplifier.
- The third pin of the PIR sensor is connected to the ground.

3.2 Pi Camera

The pi camera is a device which can capture image and video. In this project, the pi camera has been used to capture video when there is an intruder and rest when there is none due to its capabilities for capturing still images and videos. The camera module in this project is an image sensor well connected with control electronics, a lens, the Ethernet and an interface such as Camera Serial Interface (CSI). Raspberry Pi camera is attached to a small printed circuit board which is then connected to the raspberry pi via a camera board. The camera can deliver a clear image, 5mp resolution and video recording at 1080HD. [19, 13]. It is connected to the port opposite of Ethernet port in the raspberry pi. The ribbon cable which is extendable enables the attachment of Printed Circuit Board (PCB) and allows for the connection of the camera to the pi via its port.

The device is enabled by importing and installing the camera from the Raspbian operating system.

The camera on the board is small with specifications of 5 MP which are explicitly made for the pi. The camera uses 250 mA; therefore, an external powering of the pi is sufficient for use in this surveillance system.

Raspberry pi enables a configuration of the threshold to the number of pixels needed for proper detection of movement by the pi camera. An increase in the limit to 3000 pixels ensures that the camera takes pictures only when an adequate movement has taken place.

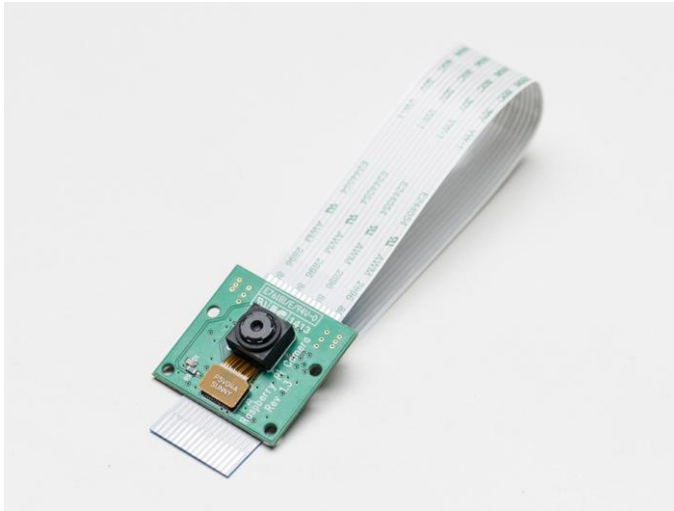

Figure 13. Pi Camera

A code is used to enable the operations of the pi camera

3.3 Raspberry Pi 3

Raspberry Pi 3 is a cheap single-board computer manufactured by Raspberry Pi foundation. It is an improved model from the previous versions and is based on Broadcom system-on-a-chip [20, 3]. The model has both a higher clock speed and an onboard Wi-Fi and with built-in Bluetooth. Raspberry pi 3 runs at 1.2 GHz and has an upgraded power system as well as four USB ports. [19, 10]. Raspberry Pi 3 used in my design system and its hardware is as shown in fig 14 below;

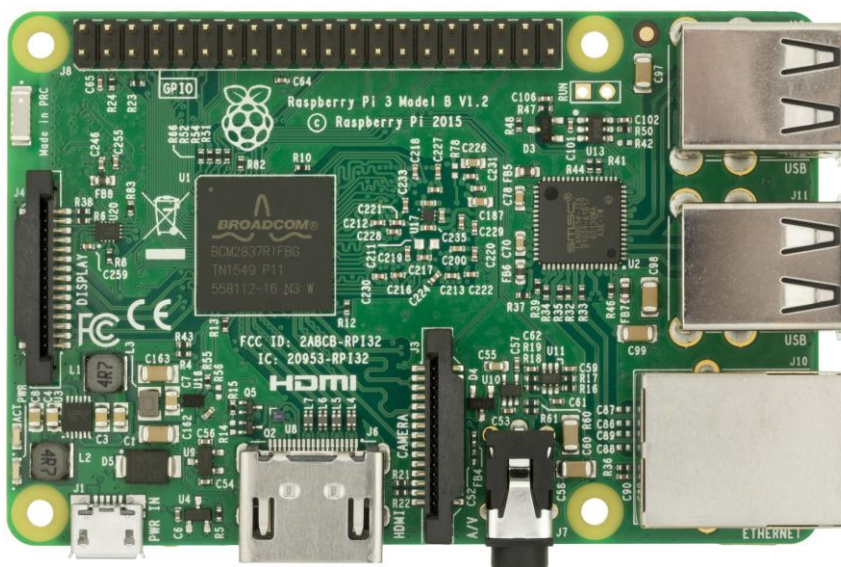

Figure 14. Raspberry Pi 3 Hardware

Different OS for the Raspberry Pi can be installed on a Micro SD, Mini SD or SD card, dependent on the board and available adapters.

Raspberry pi is a minicomputer, hence has ports which necessitate the wiring of the project. Powering source comes from the PIR sensor, that is, only the sensor is powered, and it relays the power to the other devices in the connections like the raspberry module and pi camera. Starting from the PIR sensor, positive terminal is connected to pin 2 of raspberry pi, ground to pin 6, and the third terminal to pin 11. The project responds positively when powered on. Several pins of the raspberry pi module make it possible to integrate several devices according to the objective. The following diagram has been used for illustration. The flow diagram shows how the PIR sensor behaves when there is an intruder and no intruder. It registers a 1 and 0 when there is an intruder and not respectively. The PIR sensor used is a wired sensor of 5V DC. Fig 15 below illustrates the system flow diagram.

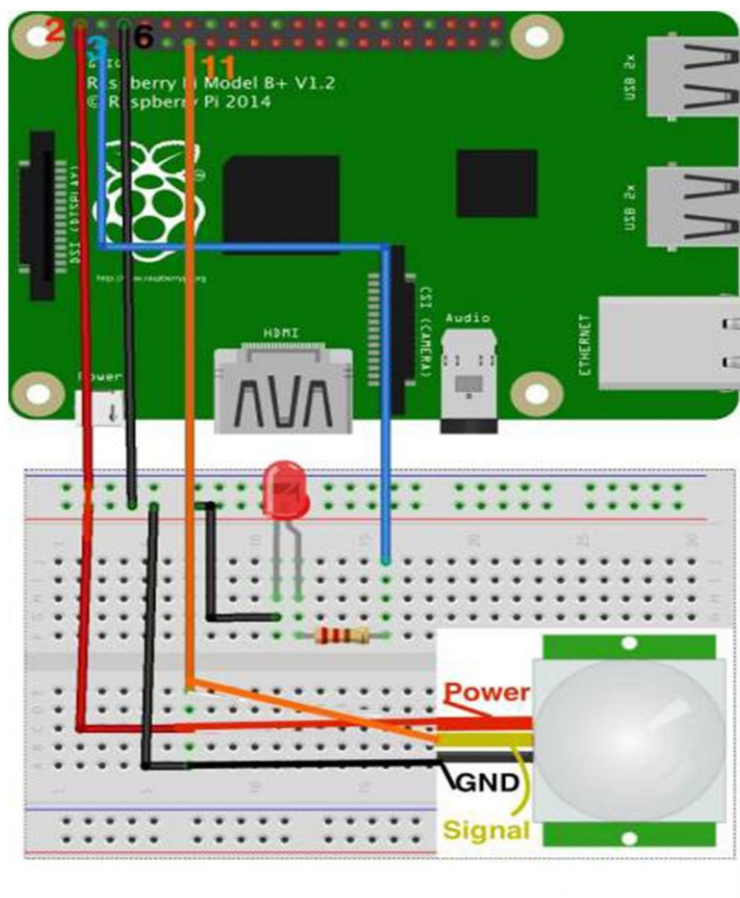

Fig 15. System flow diagram

Raspberry pi is the foundation of the surveillance project. It enables the functioning of the pi camera for motion detection through a preinstalled software called Motion. An available configuration file is used for making the necessary adjustments on the pi camera behavior. With this program, the camera setting as regards streaming, picture taking, and image and motion detection are controlled.

The PIR code illustrated in appendix 1 was employed in enabling the PIR sensor. Code flow diagram is as shown below in figure 16.

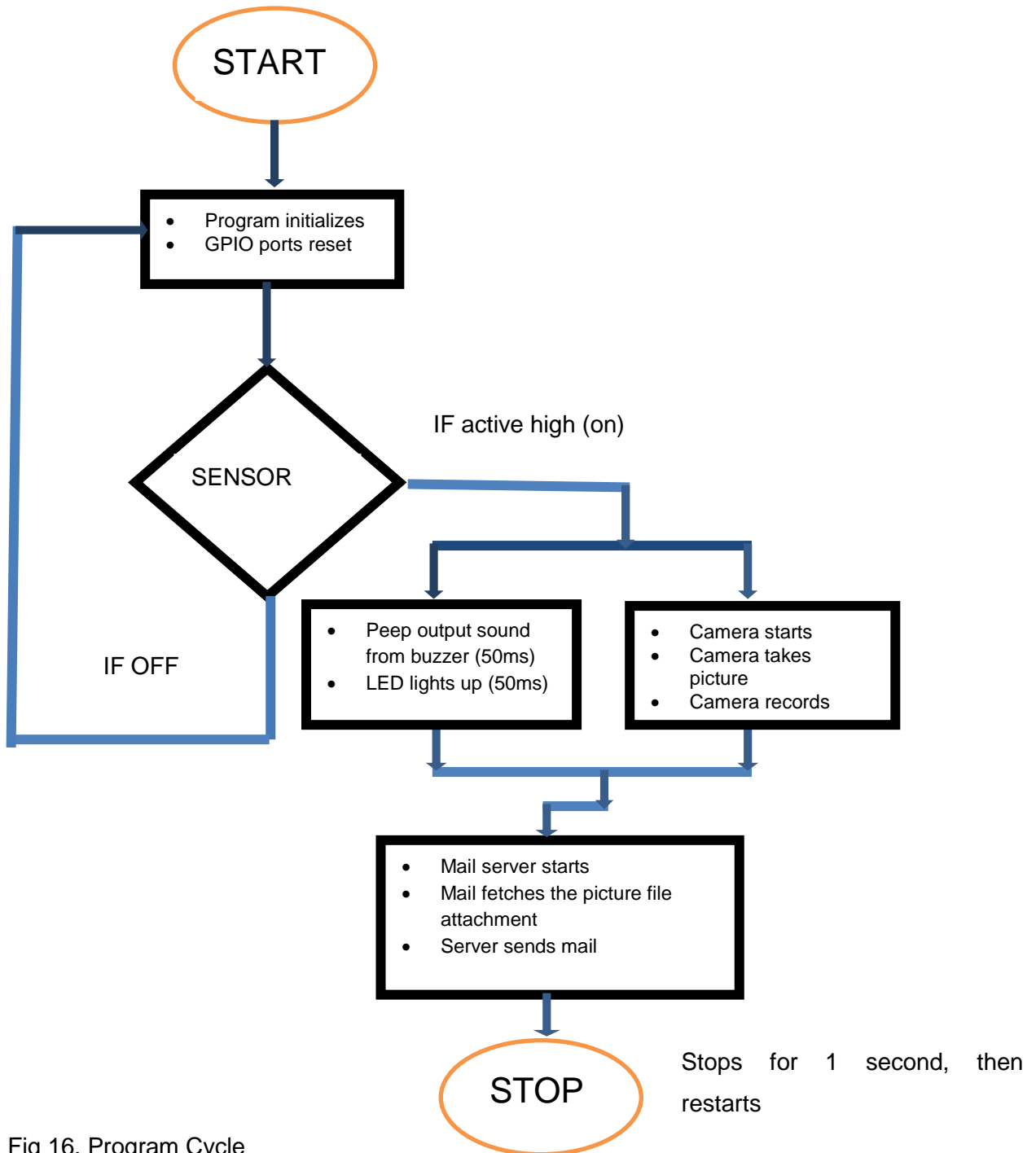

Fig 16. Program Cycle

Set up and conditions in GPIO is defined.

GPIO is allocated to corresponding devices for relay. Pin 8, 11, 13 is set for sensor, Piezo buzzer and LED respectively. The sensor input pin 8 is allocated for sensing motion, output pin 11 for Piezo buzzer and output pin 13 that drives the LED. They all, when GPIO state is high (GPIO=1) and codes activated, give outputs accordingly.

GPIO states, with reference to PIR codes of appendix 1, enables the various hardware components to function. Access to various modules is provided by GPIO and is dependent on its state.

During 'GPIO=0' state, the sensor is at rest (off). There is no output from the sensor and it remains at 'rest' state if nothing is detected.

Motion sensor gets turned on, when there is possible intrusion (high state 'GPIO 8=1'). The camera, LED, buzzer and timer is simultaneously activated. The camera captures image and records video. The email architecture is initiated, where it fetches the image captured, encodes and attaches to the mail and sends to the recipient. The video captured will be saved in the module memory.

The program stops for 1 second to perform GPIO reset to avoid false alarms and restarts. The program developed keeps running and every time an intruder comes in the detection range of the sensor, the process repeats.

3.4 Raspbian OS

For this project, raspbian Operating System (OS) is used to run the surveillance system. It is an essential system for the PIR-based system, since it provides an optimum performance of RPI [21,910]. Additionally, raspbian OS is not purely an OS as it comes with numerous packages and pre-combined software for ease of installation and efficiency of operations of PIR-based projects.

According to Listing 1 codes previously demonstrated, all the operations of the system are together run by the program, and the output is relayed to the assigned hardware and software components. To have a video recording of an intrusion, the file for video camera should contain the codes. When an individual presses the button for video recording, the code is activated for the period specified. LED will light up during recording to let the user know that video recording has been activated. The video will be saved with the current date and time as the filename once the record is complete. The components involved in video recording include: Raspberry Pi, resistor, jumper wires, LED and Raspberry Pi camera.

PIR camera file contains the codes for motion detection and sending an email alert. Video and picture can at the same time be captured an action that involves two buttons on the raspberry pi. A file that corresponds to the operation should contain the codes for the procedure. The code will set GPIO pins 17 and 18 as Input with the internal pull-up resistors. One button (connected to GPIO 17) records a given duration video. The other button (connected to GPIO 18) captures a picture. Both video and picture files are saved to the Documents folder with the current date and time as the filename.

The code will initialize a PIR (Passive Infrared) sensor that is used to detect motion [22,61]. If the PIR sensor perceives motion, the Pi camera will take a picture in the area of motion and send an email of the photo to a specified email address. Raspbian OS needs a program that allows for emails to be sent. Such a program is SSMTP, a program that allows the system to deliver emails from a local computer to an email address specified. The program is ideal for this project, since it allows the system to email notifications upon human intrusion.

Generation and sending of email is a vital part of this design. Multipurpose Internet Mail Extension (MIME) package is useful for the production of email attachment of the image and video captured by the system. MIME supports characters of the non-text nature which includes video, audio and other applications programs. The package, therefore, extends the format of an email. A Simple Mail Transfer Protocol (SMTP) is then used in the delivery of the email from the raspberry pi to the configured mail hub.

To send email messages with the Raspberry Pi, an account (Gmail or yahoo) is set up at the raspberry module (smtp server). A python script is developed to implement email components for instance receiver, subject body and attachments. The process is set such that when the PIR sensor sends a high signal, the code runs fetch execute cycle.

3.5 SD Card

In this project, 8GB card is used. SD card is used for installation of the operating system, booting, and a storage/memory for the operating system, that is, for storage of recorded videos. Raspbian software is being installed in this project to interface pi camera and PIR sensor through raspberry pi.

3.6 Project Software

A proper configuration of the software and the hardware parts of the project is paramount in the project. Project software comprises of the codes that enable the various hardware components to function at optimum levels.

Python instruction 'import' gains access to various modules that builds smooth operation of the program. The program needs various hardware modules in the raspberry pi motherboard for example, camera, timer, encoder and email architecture.

3.6.1 Configuring Virtual Network Computing (VNC)

VNC is a graphical desktop sharing system that frames buffers of protocol for control of other computers or mobile phones remotely. VNC Viewer is installed on the home-owners device, personal computer, and mobile phone. VNC's inputs which include mouse, keyboard, or touch are then decoded and send to VNC Server installed on Raspberry Pi module to instruct and ensure control of the actual node device remotely.

4 Results and Discussion

4.1 Results

4.1.1 Human Detection

Human detection part of the project entirely depended on the program responsible for the subtraction of any background noises. The PIR sensor responsible for the detection of motion adjusts itself to the infrared signature of its surroundings and keeps watching for any changes. In the absence of motion, the LED indicator will remain dim, and the program will continue updating the surroundings. If the sensor detects movement, the frame for motion detected will be the input frame to the process of human detection, and consequently, the motion detection indicator will light up.

4.1.2 Image Capture and Video Recording.

Upon confirmation of intrusion of a human in the field of view of the sensor, the Passive Infrared sensor triggers the pi camera through the Raspberry pi. RPI directs instructions to the pi camera to click the picture and consequently save it. While capturing the image of the intruder, the pi camera records video of the occurrence and keeps it with a name containing the date and time of entry. Below in figure 17 is a captured image by the surveillance.

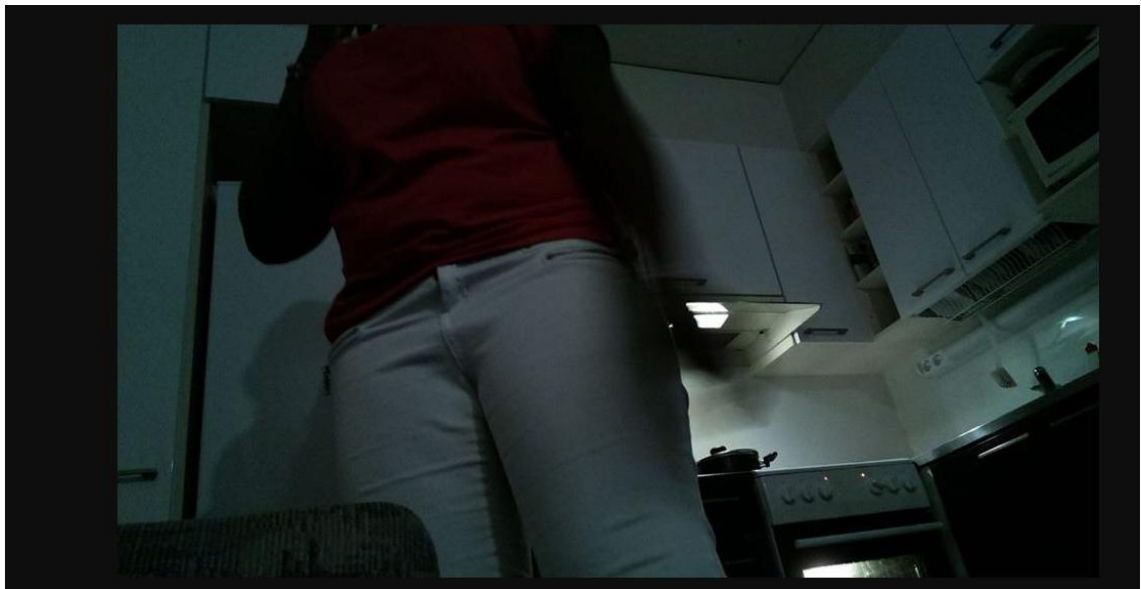

Fig 17. Image Captured

And here below in figure 18, a video preview

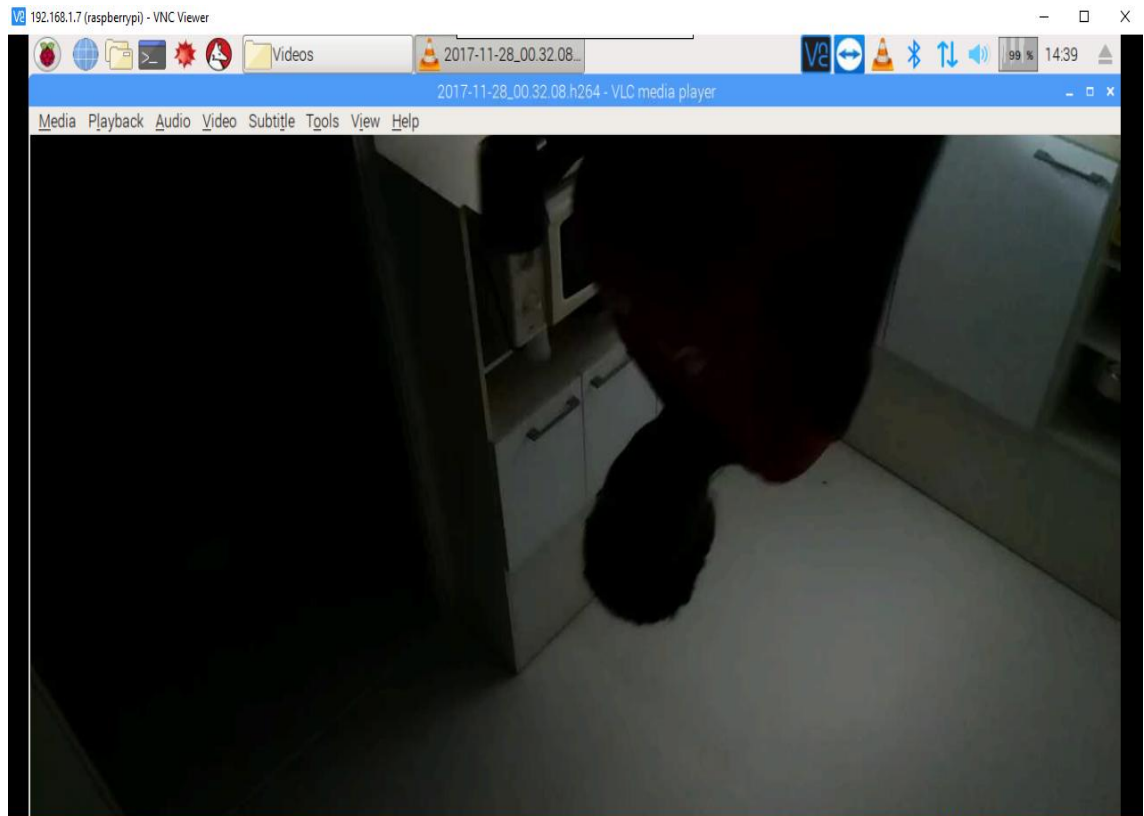

Fig 18. Video Preview

4.1.3 Email Notification

The system functions in a manner that every time motion is detected, the pi camera takes a picture and a video of the occurrence. The email algorithm obtained from the pi configuration file enables a command on the system to send an email with the photo attached to a specified email address. For this project, the homeowner, whose email has been specified during the program design and implementation, receives a notification on motion detected in the home. Below in figure 18 is a sample.

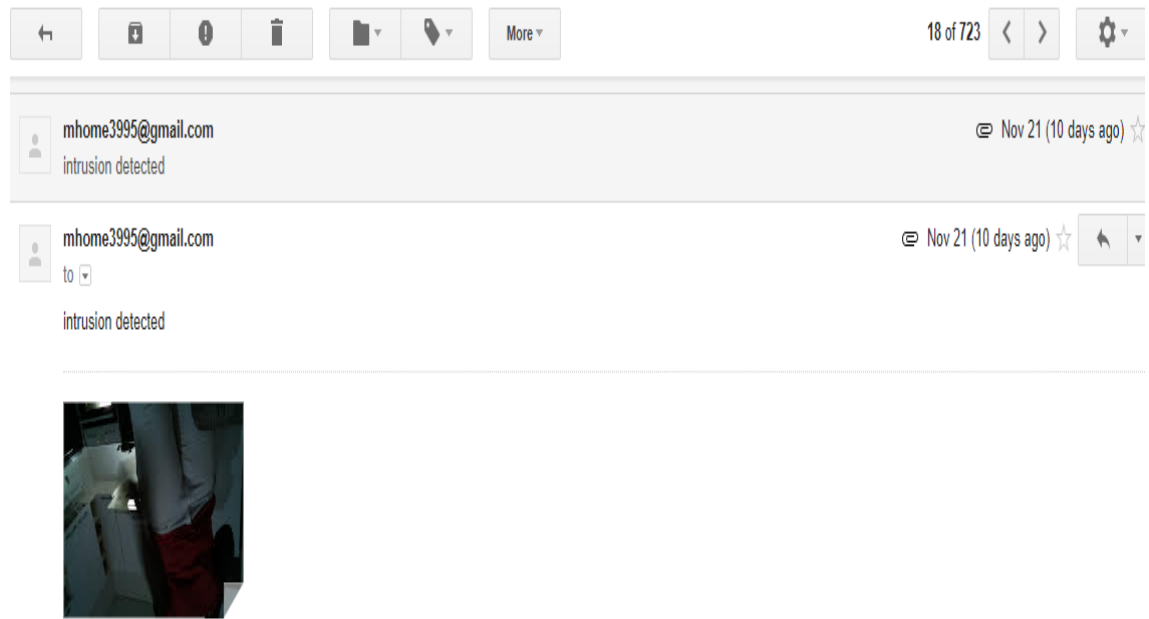

Fig 19. Email Notification

4.2 Discussion

Both the hardware and the software parts of the design are interfaced to achieve the overall objective of home security. While the hardware part contains devices that make the surveillance possible and achievable, the software drives the operations and enables the functioning of the interconnected devices. The primary objective of the project is to assure the security of the home while at the same time managing the costs associated with the installation of the surveillance system. This project has therefore relied on cost-effective devices to ensure the overall cost-effectiveness of the project.

The sensitivity of the PIR sensor is at a distance of 6 to 10 metres. A careful positioning of the sensor enhances its operations. For example, the placement of the sensor in such a way that an intruder walks across its field of vision improves its performance as it is likely to detect motion as compared to the positioning such that an intruder walks straight towards the sensor. The pi camera captures any movements within this range at the field of view of the sensor.

Raspberry pi 3 controls the programs necessary for capturing an image and sending emails. When the PIR sensor detects motion, raspberry pi enables the Pi camera to capture the image and store it. A video is recorded at the same time as a live-stream or to be reviewed by the homeowner later. The system immediately converts the image captured by the pi camera to greyscale, improves image contrast and consequently

stores it in the memory. The step is necessary to the improvement of the program's processing speed. Haar classifier stages are useful in processing the converted image. The program considers the image as that of a human only if the shoulder and head features are detected.

Haar-like features are one among many methods for detection of an object. It is similar to the human detection method where the researchers using this method applied the use of shoulder and head characteristics as Region of Interest rather than the use of the usual face detection. [23,130].The basic shape-like face in any appearance can occur on a different scale, orientation, and position. In human detection, the task is more perplexing due to the largely variable shapes, sizes, clothing, and posture.

The security of the home is only assured when the homeowner is aware of the happenings in the house. The system designed in this case alerts the homeowner about any intrusion in the home via an email alert to the homeowner's email address earlier on specified. The email will inform the homeowner of an invasion and has an attachment of the picture of the intruder. At this point, the owner of the home can take the necessary steps to avoid any damage to the property [24,17].

5 Conclusions and Recommendation

5.1 Conclusion

With an improved awareness of the importance of home security, homeowners are on the lookout for an efficient surveillance system which is cost-friendly. This design covers all the vital areas of a home security system. Detection of intrusion into the home is made possible using passive infrared sensors. The sensor uses the infrared radiations changes as a result of human motion across its field of movement. When movement is detected, the pi camera, with the capabilities for taking pictures and recording videos, is enabled. The picture attachment alongside the recorded video is then sent to a specified mail recipient, who is the homeowner.

The system designed is energy efficient and is applicable particularly in areas with low energy supply as a result of inadequate electricity supply. The method additionally offers flexibility and reliability. It enables the owner to be aware of the security situation at home provided he/she is connected to the internet.

The use of CCTV in surveillance has been associated with more cost as a result of the need for a computer, additional space required for continuous recording of occurrences, and the necessary manpower to monitor and detect motion or human intrusion. The system design in this project overcomes this challenge through the use of raspberry pi which is cost-friendly, low power consumption and high-resolution power. For home security, the system is efficient as since it is applicable for surveillance of small personal areas.

5.2 Recommendations

The PIR-based security system is recommended for residential properties for efficiency and effectiveness of home surveillance. Some shortcomings of the system, however, are related to the sensitivity of the PIR sensors. More work is required in the determination of the right materials for use in the manufacture PIR sensors to increase its ability to detect any kind of human movement across or along its path.

Most surveillance systems require the use of power for its operations. Further studies should be carried out on the potential use of PIR-based home surveillance system in

remote areas with no access to any source of power. For example, research should be conducted on the use of solar powered PIR based security systems.

References

1. Hasan M, Hossain E, Niyato D. Random access for machine-to-machine communication in LTE-advanced networks: issues and approaches. *IEEE communications Magazine*. 2013 Jun;51(6):86-93.
2. Prasad S, Mahalakshmi P, Sunder AJ, Swathi R. Smart Surveillance Monitoring System Using Raspberry PI and PIR Sensor. *Int. J. Comput. Sci. Inf. Technol.* 2014 Jun;5(6):7107-9.
3. IT-CCTV-RP AP. Selection of Cameras, Digital Recording Systems, Digital High-Speed Networks and Trainlines for Use in Transit-Related CCTV Systems.
4. Bunting T, inventor. Glass Break Detector. United States patent application US 15/207,501. 2016 Jul 11.
5. Adonailo RS, Li TT, Zakrewski DS, inventors; Honeywell International, Inc., assignee. False alarm reduction in security systems using weather sensor and control panel logic. United States patent US 7,218,217. 2007 May 15.
6. Albert DE, inventor; Innovalarm Corporation, assignee. Enhanced fire, safety, security and health monitoring and alarm response method, system and device. United States patent US 7,173,525. 2007 Feb 6.
7. Cleary TG, Chernovsky A, Grosshandler WL, Anderson M. Particulate entry lag in spot-type smoke detectors. *Fire Safety Science*. 2000;6:779-90.
8. Yavuz So, Taşbaşı A, Evirgen A, Kara A. Motion Detector with PIR sensor usage areas and advantages.
9. Pretty B. Building a Home Security System with BeagleBone. Packt Publishing Ltd; 2013 Dec 17.
10. Rodic A, Katie D, Mester G. Ambient intelligent robot-sensor networks for environmental surveillance and remote sensing. In *Intelligent Systems and Informatics, 2009. SISY'09. 7th International Symposium on 2009 Sep 25* (pp. 39-44). IEEE.
11. DIVE GD. Sensing Impacts: Remote Monitoring using Sensors.
12. Hart-Davis G. Deploying Raspberry Pi in the Classroom. Apress; 2017.
13. Dennis AK. Raspberry Pi Computer Architecture Essentials. Packt Publishing Ltd; 2016 Mar 22.
14. Alee R. Reading data from a digital multimeter using a Raspberry pi.
15. Dhake PS, Borde SS. Embedded Surveillance System Using PIR Sensor. *International Journal of Advanced Technology in Engineering and Science*. 2014 Mar; 2 (3).
16. Aggarwal S. Principles of remote sensing. *Satellite remote sensing and GIS applications in agricultural meteorology*. 2004; 23.

17. Cho S, Shin MH, Kim YK, Seo JE, Lee YM, Park CH, Chung JH. Effects of infrared radiation and heat on human skin aging in vivo. In *Journal of Investigative Dermatology Symposium Proceedings 2009 Aug 31* (Vol. 14, No. 1, pp. 15-19). Elsevier.
18. Chowdhury ZI, Imtiaz MH, Azam MM, Sumi MR, Nur NS. Design and implementation of pyroelectric infrared sensor based security system using microcontroller. In *Students' Technology Symposium (TechSym), 2011 IEEE 2011 Jan 14* (pp. 1-5). IEEE.
19. Desai G. IoT approach for motion detection using raspberry Pi.
20. Nguyen HQ, Loan TT, Mao BD, Huh EN. Low cost real-time system monitoring using Raspberry Pi. In *Ubiquitous and Future Networks (ICUFN), 2015 Seventh International Conference on 2015 Jul 7* (pp. 857-859). IEEE.
21. Madhuravani B, Rashmika M. Motion sensor and face recognition based surveillance system Using Raspberry Pi. *International Journal*. 2017 May 1;8(5).
22. Hart-Davis G. Choosing Operating Systems for Raspberry Pi. In *Deploying Raspberry Pi in the Classroom 2017* (pp. 55-69). Apress.
23. Wilson PI, Fernandez J. Facial feature detection using Haar classifiers. *Journal of Computing Sciences in Colleges*. 2006 Apr 1;21(4):127-33.
24. Robles RJ, Kim TH, Cook D, Das S. A review on security in smart home development. *International Journal of Advanced Science and Technology*. 2010 Feb;15.
25. Passive Infrared (PIR) Sensor Based Security System (PDF Download Available). Available from: https://www.researchgate.net/publication/250928842_Passive_Infrared_PIR_Sensor_Based_Security_System [accessed Sep 27, 2017].
26. <https://www.smarthome.com/sensors-security/occupancy/door-window-sensors.html>[online].
27. A. Tarun "Know about Passive Infrared Sensor (PIR) with Projects" [Online]. Available: <https://www.elprocus.com/passive-infrared-pir-sensor-with-applications/>[Accessed Sep 13, 2017].
28. Focusing devices for pyroelectric infrared sensors[Online]. Available from: <http://www.glolab.com/focusdevices/focus.html> [accessed Sep 22, 2017].
29. Passive Infrared (PIR) Fresnel Lenses[Online]. Available: http://www.orafol.com/tl_files/EnergyUSA/documents/PIR%20Lenses.pdf [Accessed Oct 11, 2017].
30. <https://www.theurbanpenguin.com/raspberry-pi-model-b-hardware/> [online]. [Accessed Sep 20, 2017].
31. <https://www.elprocus.com/working-of-different-types-of-motion-sensors/> [online]. [Accessed Nov 12, 2017].

32. <http://www.instructables.com/id/Raspberry-Pi-Motion-Detection-Security-Camera/> [online]. Accessed on Sept 13, 2017]

Appendices

Appendix 1- PIR Code [32]

```

import smtplib (email server used for actual sending function.
Native python library that sends emails)
from email.mime.text import MIMEText (email parameter. imports
email modules)
from email.mime.multipart import MIMEMultipart (email package
module which extends email format that support text characters)
from email.mime.base import MIMEBase
from email import encoders (Email package that provides conven-
ient encodings in its encoder module. They extract payload, re-
set, encode it to newly encoded value)
from email.mime.image import MIMEImage (Provides default encod-
ings for image)
import base64 (encoding function. Encodes payloads data and
translate it into a base 64 representation)
from picamera import PiCamera (Installs pi camera module)
from time import sleep (python timer module for pausing or stop-
ping)
import RPi.GPIO as GPIO (Enables to refer just as GPIO all
through the script)
import time (Cycle module that provides for time related func-
tions)
import picamera (Initializes the Pi camera)
import datetime (Module date and time function)

#Numbering IO pins on Raspberry Pi within RPi. GPIO#
sensor = 8
piezo = 11
led = 13 (board numbering system)

camera = PiCamera()

#gpio setup and conditions#
GPIO.setmode(GPIO.BOARD) (Specifies pin numbering which has been
used (board))
GPIO.setup(sensor, GPIO.IN, GPIO.PUD_DOWN) (Motion sensor input
pin allocation)

```



```

GPIO.setup(piezo,GPIO.OUT) (Buzzer output sensor allocation)
GPIO.setup(led,GPIO.OUT) (Led output pin)
GPIO.setwarnings(False) (Instruction to ignore gpio false warn-
ings when the program is in loop)
previous_state = False (Initial state of the gpio pins)
current_state = False (Present state of the gpio pins)
while True: (Repeat the expression or loop as long as condition
is true)
sleep(0.1) (module initial condition at loop)
previous_state = current_state (Module current condition)
current_state = GPIO.input(sensor) (Gpio input sense by motion
detector)
if current_state != previous_state: (Sense condition)
    new_state = "HIGH" if current_state else "LOW" (Presence of
high signal at Pin 8)
    camera.start_preview() (Camera service starts up)
    camera.capture ('/home/pi/Desktop/image.jpg') (Image captured
and stored at the desktop)
    fileName = datetime.datetime.now().strftime('/home/pi/Videos/%Y-
%m-%d_%H.%M.%S.h264') (The video file name for video recording
with time stamp)
    camera.start_recording(fileName) (Actual video recording for
above filename)
    time.sleep(10) (Camera recording for 10 seconds)
    camera.stop_recording() (Camera video recording stops)
    camera.stop_preview() (Camera service stops )
    GPIO.output(piezo,True) (Buzzer goes off , beep and sound pro-
duced)
    GPIO.output(led,True) (Led warning goes off , led lights up)
    print("GPIO pin %s is %s" % (sensor, new_state), 'motion de-
tected')
    (python terminal displays active GPIO input pin, for this case
pin 8)

#smtp server and host email server#
me = 'mhome3995@gmail.com' (Host mail configured into mail util-
ity)

```

```

subject = 'intrusion mhome' (Host mail subject)
msg =MIMEMultipart() (Mail architecture)
msg['subject'] = subject (Mail subject line above)
msg['From'] = me (Mail address source above)
body = 'intrusion detected' (Mail text )
msg.attach(MIMEText(body,'plain')) (Instruction for attaching
the body to the email architecture)
filename='/home/pi/Pictures/image.jpg' (Instruction that reads
picture location)
attachment =open(filename,'rb') (Instruction that identifies
picture location)
part = MIMEBase ('application', 'octet-stream') (Instruction to
initialize an application- octet stream)
part.set_payload((attachment).read()) (The application octet
stream is directed to read the attachment in binary)
encoders.encode_base64(part) (Translating the mail to 64base
system used by the raspbian Operating environment )
part.add_header('Content-Disposition',"attachement;      filename=
"+filename) (Uploads picture file name)
msg.attach(part) (Upload of the picture file on the architec-
ture)
text = msg.as_string() (Instruction that keep the body of the
message complete and final with no more modification for the
server to send)
server = smtplib.SMTP('smtp.gmail.com',587) (Server start up)
server.starttls() (Server uses a secure transport layer security
protocol to run the mail and encode and delivery)
server.login('mhome3995@gmail.com', 'safe3995') (Server opens
the host mail)
server.sendmail('mhome3995@gmail.com','tarus.zipporah@gmail.com'
, text) (Server sends the mail)
server.quit() (Server shuts down)
GPIO.output(piezo,False) (Buzzer goes silent)
GPIO.output(led,False) (Led lights goes out)
sleep(1) (PIR module refreshes for 1 second and returns to loop)

```

Listing 1. PIR Code