



VAASAN AMMATTIKORKEAKOULU  
UNIVERSITY OF APPLIED SCIENCES

Miika Kujansuu

# REFORMATION OF THE TEST RACK

School of technology  
2016

## **FOREWORD**

First of all I would like to thank my thesis supervisors Joni Kentta from ABB and Olli Tuovinen from Vaasa University of Applied Sciences for giving me guidance and feedback for the documentation. I would also like to thank people who assisted me to fulfil the thesis functions especially Perttu Eskelä and Harri Mäki-Paavola.

The thesis about protection relays was a new thing for me and it taught me very much about them. I got to know plenty about relay functions, circuits, capabilities and data transfer protocols. We did not know what this thesis would be in the end, because there were so much opportunities how to execute and what kind of rack we wanted to create. The documentation part was hard to produce, because after a physical part there was so much information to remember and I needed to get it all into documentation.

## TIIVISTELMÄ

Tekijä	Miika Kujansuu
Opinnäytetyön nimi	Reformation of the Test Rack
Vuosi	2016
Kieli	englanti
Sivumäärä	40
Ohjaaja	Olli Tuovinen

---

Opinnäytetyön tarkoituksena oli toteuttaa ja dokumentoida ABB Oy Medium Voltage Productin PVC:lle tuotekehitysprojekti 615 sarjan suoja-releiden uudesta testausjärjestelmästä, mikä olisi valmiimpi automaatiotestaukseen, sekä olisi turvallisempi ja asiallisempi.

Toteuttamiseen vaikutti testaamisen vaatimukset, turvallisuus ja valmius automaatioon. Esimerkiksi suoja-releestä pitää saada testattua kaikkien kytkinlaitteiden simuloinnit jokaisessa erilaisessa standardi konfiguraatiossa, sekä uuden suoja-releen vaihto testausjärjestelmään ilman mitään johtojen purkamista ja kytkemistä.

Järjestelmä saatiin toteutettua ja on tällä hetkellä käytössä. Järjestelmän toteuttaminen vei paljon aikaa fyysisen puolen suunnittelussa ja sen toteuttamisessa. Tämä oli ensimmäinen askel automaatiotestaukseen päin. Järjestelmää tullaan korjaamaan vielä varmasti ja sitä tullaan kehittämään eteenpäin vielä tosi paljon. Järjestelmän lopputavoitteena on saada kehitettyä järjestelmälle omat ”aivot”. Tarkoittaen sitä, kun uusi suoja-rele laitetaan järjestelmään niin järjestelmä osaa tunnistaa asennetun suoja-releen ja ohjelmoi johdotuksen automaattisesti oikein.

## ABSTRACT

Author	Miika Kujansuu
Title	Reformation of the Test Rack
Year	2016
Language	English
Pages	40
Name of Supervisor	Olli Tuovinen

---

The purpose of the thesis was to develop the relay testing system for the 615 series protection relay and create a document for PVC. The testing system need to be safer, more proper and ready for automatic testing.

The requirements affected the final results. The new testing system needs to be able to simulate breakers and switches for all standard configurations. The testing system must be able to adapt for a protection relay swap without any physical changes.

The requirements were completed and the system is in use. The design and implementation of the physical part took a lot of time. This was the first step towards automatic testing. The system will be updated in future and developed further. The end result in this is to develop the own "brains" for testing system, meaning the wiring will set up automatically after swapping a new protection relay to the system.

---

Keywords: automatic, safety, testing, development, Arduino

## CONTENTS

### TIIVISTELMÄ

### ABSTRACT

1	INTRODUCTION .....	5
2	ABB .....	6
	2.1 Medium Voltage Products .....	6
	2.2 Product Verification Center .....	7
3	DISTRIBUTION AUTOMATION (DA).....	8
	3.1 Protection and Control of Distribution Network .....	9
	3.1.1 Network Protection .....	9
	3.1.2 Control of electrical network .....	10
	3.2 Protection Relay the IED .....	11
	3.2.1 Different Types of Protection Relays.....	12
4	AUTOMATIC TEST RACK FOR 615 SERIES .....	15
	4.1 The Main Aims .....	15
	4.2 Test Rack Configuration .....	17
	4.2.1 Rack structure.....	17
	4.2.2 Device locations .....	19
	4.2.3 Electric cabinet for Arduino.....	20
	4.2.4 Test preparations .....	21
	4.3 Safety Standard Compliance.....	24
	4.3.1 Protection against electrical shock.....	24
	4.3.2 Replacing the IED .....	24
	4.3.3 Help for using the rack.....	24
	4.4 Customer Friendly .....	25
	4.5 Standardised Wires and Devices.....	25
	4.6 Flexibility.....	25
	4.7 Comprehensive Documentation.....	26
5	PREPAREDNESS FOR AUTOMATIC TESTING .....	27
	5.1 Configuration Modifications by PLC/Arduino .....	27

5.2	Arduino .....	29
5.3	AC800M Programming .....	30
5.3.1	New Function Block for Signal Guiding .....	31
5.3.2	Software of Function Block .....	32
5.4	Future Automatic Testing Projects .....	34
6	CONCLUSIONS .....	35
	REFERENCES.....	36

## LIST OF FIGURES AND TABLES

<b>Figure 1.</b> Protection relay .....	6
<b>Figure 2.</b> PVC laboratory, ABB Vaasa Finland .....	7
<b>Figure 3.</b> DA-Concept .....	8
<b>Figure 4.</b> Electrical network, Fault situation .....	10
<b>Figure 5.</b> Electrical network, Fault, Relay communication.....	11
<b>Figure 6.</b> Front side of 615 series (ANSI).....	13
<b>Figure 7.</b> Front side of 615 series (IEC).....	13
<b>Figure 8.</b> Rear side of 615 series .....	14
<b>Figure 9.</b> Front side of the rack .....	17
<b>Figure 10.</b> Rear side of the rack .....	18
<b>Figure 11.</b> Electric cabinet .....	20
<b>Figure 12.</b> Function sequence.....	28
<b>Figure 13.</b> Arduino Mega2560 and relay circuit .....	29
<b>Figure 14.</b> AC800M .....	30
<b>Figure 15.</b> Function Block.....	31
<b>Figure 16.</b> Functionality of the Binary inputs .....	32
<b>Figure 17.</b> Configurations of IED .....	33
<b>Table 1.</b> Arduino commands 1 to 13 .....	22
<b>Table 2.</b> Arduino commands 20 to 40 .....	23

**LIST OF USED ABBREVIATIONS**

ANSI	American National Standards Institute
I/O	Input and Output
IEC	International Electrotechnical Commission
IDR	Internal Defect Report
IED	Intelligent Electronic Device
PVC	Product Verification Center
R&D	Research and Development
DA	Distribution Automation
CB	Circuit Breaker
ES	Earth Switch
DC	Disconnecter
SCADA	Supervisory Control And Data Acquisition
SLD	Single-Line Diagram
V	Voltage
A	Ampere
NO	Normal open
NC	Normal close
BI	Binary input
BO	Binary output
DI	Digital input
DO	Digital output
HMI	Human Machine Interface
WHMI	Web Human Machine Interface



## 1 INTRODUCTION

This thesis is a step towards automatic testing of Medium Voltage Products protection relays.

The project was started because the relays have different configurations. Always when a new different type of relay needs to be tested, the wiring has to be modified. The new rack designed in this thesis makes the wiring changes unnecessary. The automatic testing system for 615 series is needed for saving work time and because there will be no new variables for 615 series so the rack can be designed to the very end.

A decision was made to use Arduino for wiring adaptations. This is implemented by Arduino controlled interposing relays which handle the physical part of the wiring cross-connection. Interposing relays are activated according to tested protection relay configuration.

The thesis gives basic information of protection relays and relay's tasks in distribution network. The main aim is to give information about created test system for ABB medium voltage products.

Second chapter is about ABB including the Medium Voltage Products and Product Verification Center. Third chapter is for Distribution Automation including information of protection relays. From fourth chapter is information of main aim the created test system for 615 series protection relays.

## 2 ABB

ABB is a leading global power and automation technology group whose head office is located in Zurich. ABB operates in around 100 countries and have 140 000 employees. 5200 of those employees work in Finland.

The revenues in 2014 was about 40 billion USD. ABB uses over 1, 5 billion USD for R&D. /1/

### 2.1 Medium Voltage Products

ABB Medium Voltage Products (MVP) department is leading the global transition to the digital grid. The mission is to support customers by providing innovative and reliable solutions for distribution networks.

ABB offers distribution automation solutions to improve:

- Personnel safety
- Power network reliability

Main products of MVP are different types of protections relays (Figure 1) which recognize abnormal power system conditions, or abnormally operating system components. /2/



**Figure 1.** Protection relay

## 2.2 Product Verification Center

The role of ABB Product Verification Center (PVC, Figure 2) is to ensure high quality of IEDs and system products. PVC is creating new innovative test methods in order to decrease overall testing time and further improve product quality level. Specialized equipment is used to generate and monitor fault situations in the grid. PVC also tests all major communication protocols like IEC 61850, IEC 61850 HSR, IEC 61850 PRP, IEC 61850 self-healing, Modbus/Serial, Modbus/TCP, DNP/Serial, DNP over WAN/LAN, IEC 60870-5-103 and Profibus.



**Figure 2.** PVC laboratory, ABB Vaasa Finland

### 3 DISTRIBUTION AUTOMATION (DA)

The purpose of distribution automation is to control, operate and supervise different distribution networks. Distribution automation system consists of protection relays and supervisory SCADA system. The devices are interconnected by communication protocols which enable remote monitoring and control of the medium voltage network. Figure 3 presents the overall DA concept.

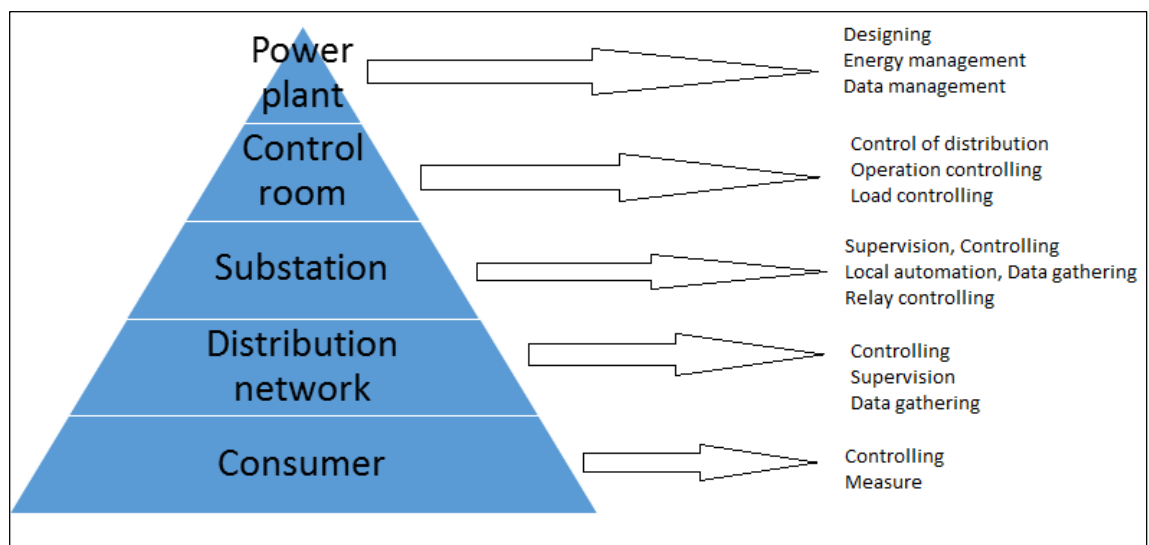

**Figure 3.** DA-Concept

Reasons for distribution automation:

- automation saves expenses
- network automation improves network availability by increasing utilization rate and reliability

Automation supports and rationalizes the operation of the electrical networks. At the same time automation makes it possible to monitor networks status. The remote controlling of disconnectors and circuit breakers helps to perform maintenance tasks much faster and easier especially in fault situations in networks. /4/

### **3.1 Protection and Control of Distribution Network**

This chapter tells more about the network protection, network control and getting to know to protection relays and its assignment.

#### **3.1.1 Network Protection**

The idea of the protection is to detect faults and abnormal operating conditions, and generate respective notifications to the operator. Protection must work fast, because it can save lives and destruction of property. When fault occurs, the automation protection must be selective to minimize power outages. Protection should be simple and reliable, and must cover fully the protected network. /4/

### 3.1.2 Control of electrical network

In different circumstances electrical network needs to be controlled. Tests, maintenance, development, troubleshooting must be performed and the most important task is to minimize the power outages of the customers. Figure 4 presents an example of fault situation in distribution network.

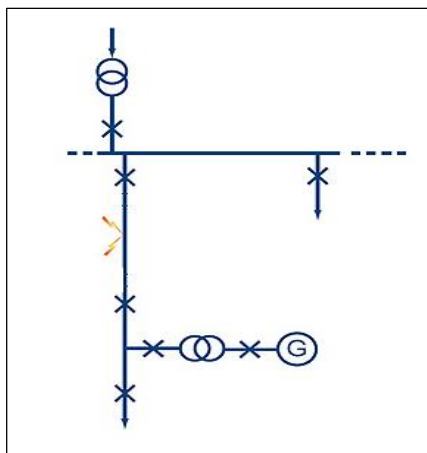
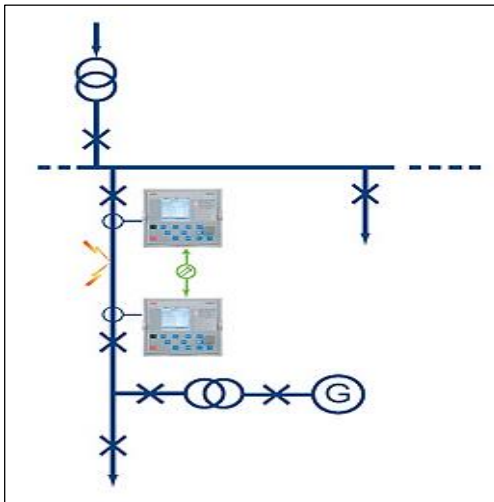

**Figure 4.** Electrical network, Fault situation

The control of the electrical network is done by disconnectors (DC) and circuit breakers (CB). DC and CB can cut off the power from the wanted part of electrical network. A breaker shuts down the high current while a DC is used to make a clear separation between the disconnected points of the line to ensure safety. The CB and DC are controlled by these MVP protection relays (IED) that are working as control units. An IED receives control orders from the supervisory control systems e.g. MicroSCADA, but the protection functions are performed inside the IED. IED supervises the execution of the control action by comparing the feedback signals to the last control command. Disconnectors and breakers normally have two position switches; open and closed. /4/

### 3.2 Protection Relay the IED

The protection relay is an intelligent electronic device (IED). The purpose of a protection relays is to -protect and control the electrical network. Relays receive control commands from the control system operator, but the protection functions are executed inside IED. An IED measures the voltages and currents of electrical network, these measurements are used for protection functions. Different calculated values are entered to relay parameters that make it cut off the power if the current or voltage goes over the preset value.



**Figure 5.** Electrical network, Fault, Relay communication

Different protection relays can communicate with other relays in the same electrical network, Figure 5. Communication is normally done by optical fiber. The message in a fault situation can be for example "a fault so open the CB". Then both of the IEDs will open the associated circuit breakers, and that part of the network is out of power but other parts will remain energised. If there is communication between the relays in the same network, as in Figure 5, then the network protection coordination becomes easier to implement. Protection relays can be controlled by HMI, WHMI or from supervisory control system (MicroSCADA). /4/

### 3.2.1 Different Types of Protection Relays

There are many types of protection relays that have different purposes and functions. Relays measure network values, protect the network from damages and generate alarms and events.

Different relay types:

- RED (Line differential and protection) (IEC)
- REF (Feeder protection) (IEC)
- REM (Motor protection) (IEC)
- RET (Transformer protection) (IEC)
- REU (Voltage protection) (IEC)
- REV (Capacitor bank protection) (IEC)
- REG (Generator protection) (IEC)
- REF ANSI (Feeder protection) (American)
- REM ANSI (Motor protection) (American)
- RET ANSI (Transformer protection) (American)

The ANSI is an American standard and protection relays are customized with different ways than IEC. The overcurrent protection function is included in all relays.

/5/



Figures 6 and 7 show the control panel of 615 series IED. The screen can display an SLD picture, as shown in Figure 6, or some optional values and measurements. SLD provides positions of disconnectors and circuit breakers, it can also show some measurements. Figure 6 shows an ANSI standard and it can be recognized from the different symbol types.



**Figure 6.** Front side of 615 series (ANSI)



**Figure 7.** Front side of 615 series (IEC)

Figure 8 shows all the connector pins of the 615 IED. The communication card is in the first slot, then there are slots X100, X110, X120 and X130 meant for the control and measurement cards. The binary inputs are located in X110, X120, and X130 card slots. The binary inputs are used as control commands to control the DC, CB, ES or some trip commands. The X100 slot is reserved for binary outputs and they are used usually for controlling CB or DC.

All these 615 series relays look the same on the outside, but they have different protection functions and different hardware configuration.



**Figure 8.** Rear side of 615 series

## **4 AUTOMATIC TEST RACK FOR 615 SERIES**

This chapter tells the main objective of the thesis. The chapter describes how the automation test rack was designed and created, how it works and what the main aims were. It is also explained what kind of the testing systems will be in future and why they are implemented in this way.

### **4.1 The Main Aims**

The aims came up with ideas what kind of racks the PVC should have.

Aims:

- future design for 615 series test rack
- in accordance with the safety standard
- complete and up-to-date documentation
- standardization of devices and wirings
- configuration adaptation can be performed by PLC/Arduino
- ground for automatic testing project

The test rack was created according to these aims. The end result was better than expected. The test rack has much more advantages than there were targets. While building the rack, more and more ideas came up how to improve the design.

The point of benefits and costs is to introduce what the rack gives or not in future.

Benefits:

- test rack structure is standard and need less manual work when configuration changes
- PLC software uses correct signals for the IED under test procedure
- Arduino controls the signals to the correct IED card connectors
- saves a lot of preparation time
- flexible in testing situations
- more ergonomic
- possibility for more diverse current testing
- surface protected from person contacts
- complete and up-to-date documentation
- **test rack is more ready for automatic testing plan**
- more impressive outer covering

Weakness:

- the rack is suitable only for 615 series
- a lot more wiring which makes repairing more difficult

## 4.2 Test Rack Configuration

### 4.2.1 Rack structure

The structure of the redesigned testing system is standardised, because originals are lacking safety and flexibility, and are difficult to maintain. The structure is based on future 615 series testing systems and technical information will be used in other design processes as well.

Equipment placed on the front of the rack is illustrated in figure 9.

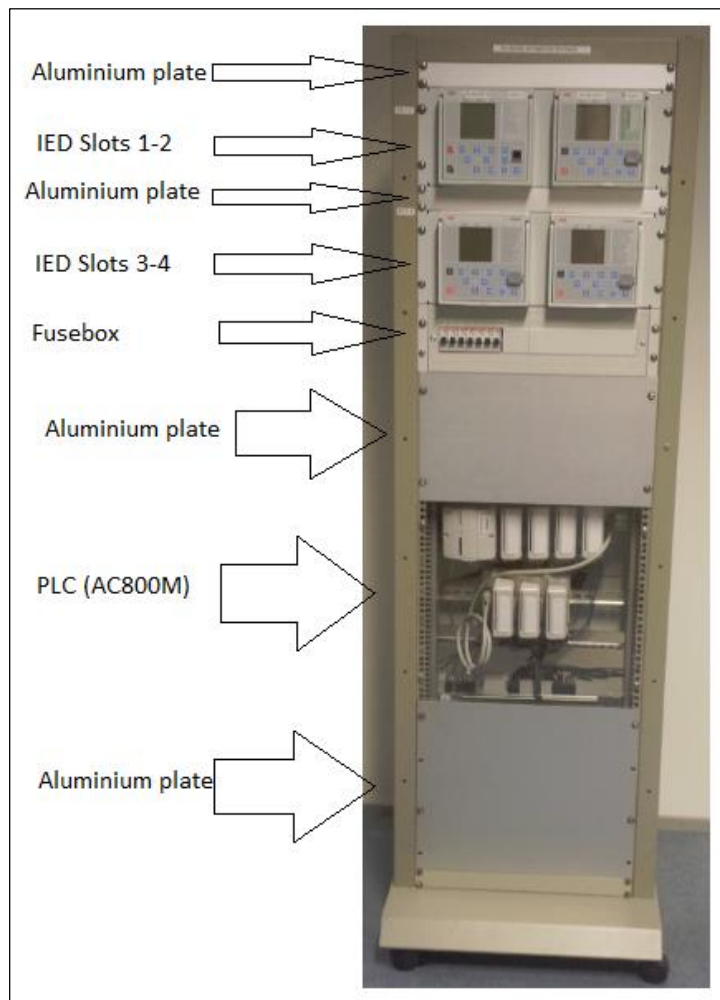

**Figure 9.** Front side of the rack

The material placed on the back of the rack is shown in Figure 10.

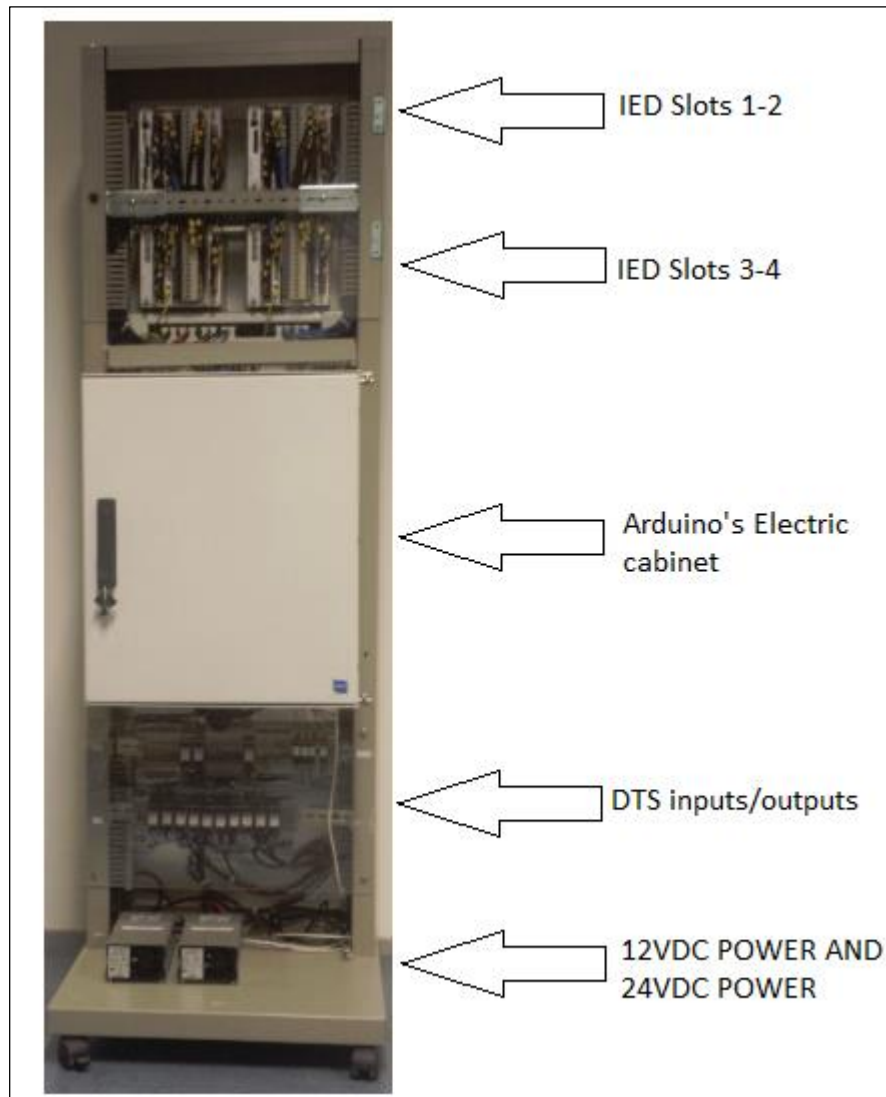

**Figure 10.** Rear side of the rack

### 4.2.2 Device locations

The IED (Relay) installation position is usually on top of the rack. The user often works with the IED manually and that's why the IED needs to be at a good height. On the rear side of the rack the IED slot connectors and wiring can be seen.

The position of fuses is deployed under the IED spots. It is a different way from the originals, because the originals have the fuses at the bottom of the rack. The fuse position is now better for the user, because it is more ergonomic.

AC800M (PLC) with the digital out/input modules is placed under the fuse box, because there is no need for any physical modifications. The height is good enough to see the led lights from the device if there is a need for verifying signals. Behind of the AC800M there is Arduino's electric cabinet which can be accessed from the rear side of the rack.

The DTS connection strips and NO/NC relays position are under the AC800M which can be seen from the rear side of the rack. DTS is process simulator for testing purposes that can supply the voltages and current to the line with a specified phase shift. The DTS can give 0 – 5A and 0 – 150V.

12 and 24 VDC power supplies positions are at the bottom of the rack, because there is no need to cut off the voltage from the main switch or do any other maintenance actions.

### 4.2.3 Electric cabinet for Arduino

The electric cabinet (600mm x 500mm x 230mm) is large space for Arduino and relay circuits and it was ordered to have extra space for wiring. Arduino is connected to relay circuits via a flat cable. One Arduino can control two relay circuits at maximum, because Arduino has 32 DI/DO sources and one relay circuit includes 16 relays. The circuit cards are mounted on the installation panel with a lot of space and the wires are above and below the circuits so in the future maintenance is much easier.

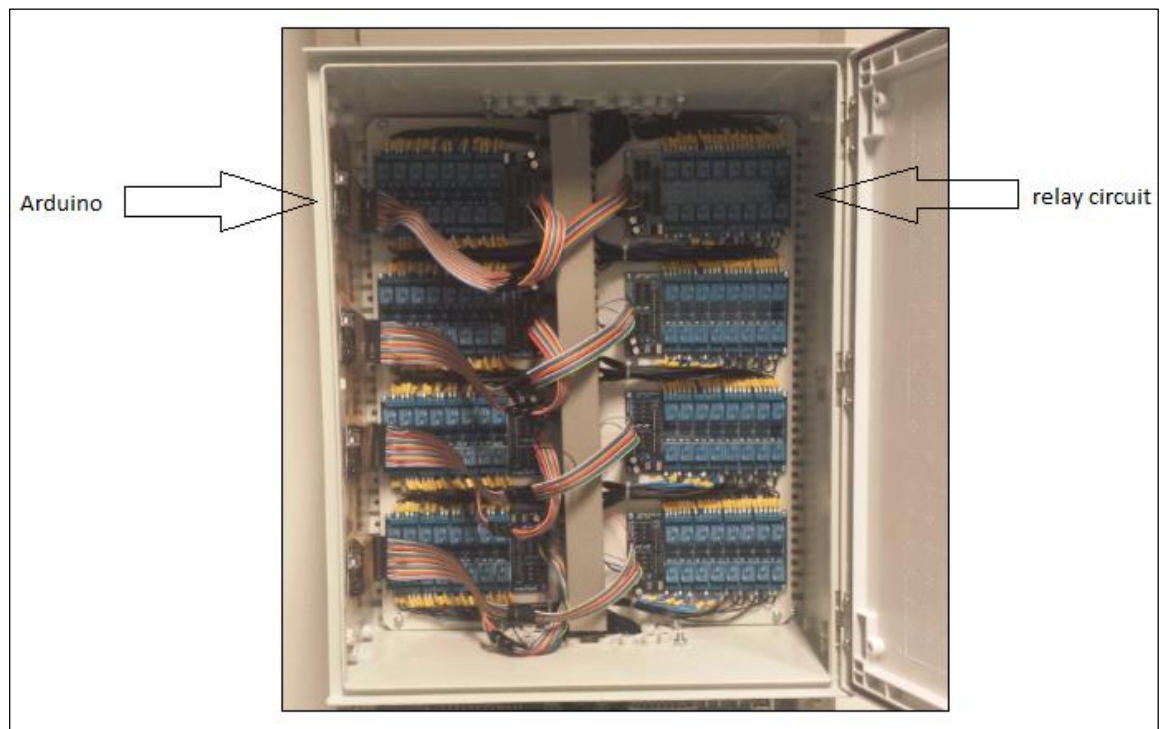

**Figure 11.** Electric cabinet



#### **4.2.4 Test preparations**

To install the protection relay to the testing system, it is necessary to know the cards inside the device and to know which binary input the IED is using for the circuit breaker position feedback. This information helps with the Arduino commands when configuring the IED.

First step with starting the new protection relay commissioning is to select the right type of IED. Selection of the IED type takes place with Arduino's commands 20 to 40 (Table 2), which specifies the type of protection relay. Second step is to give Arduino the right commands as numbers 1 to 13 (Table 1), for specifying the IED cards, measurements, location of CB and the location of the time synchronisation pulse (pulse per second). /6/

**Table 1.** Arduino commands 1 to 13

Arduino command	Determination
1	X110 slot, BIO7 card
2	X110 slot, BIO3 & BIO5 cards
3	X120 slot, $I_B$ current measurement
4	X120, $U_1$ , $U_2$ and $U_3$ voltage measurements
5	X120 slot, Using BI2 and BI3 signals
6	X120 slot, $U_0$ voltage measurement
7	X130 slot, AIM0006 card BI2 and BI3 signals
8	X130 slot, BIO4 & BIO6 cards BI2 and BIO3 signals
9	X130 slot, $V_A/U_1$ , $V_B/U_2$ , $V_C/U_3$ , $V_G/U_0$ voltage measurements
10	Reset for 1 to 9 commands
11	Second pulse to X110 card's BI1
12	Second pulse to X120 card's BI1
13	Second pulse to X110 card's BI3

**Table 2.** Arduino commands 20 to 40

Arduino command	Determination
20	IED type (DE01,DE02, DE03, DE04, ME03)
21	IED type (DE05, ME04, FE11)
22	IED type (FE01, FE03, ME01)
23	IED type (FE02, FE04, FE05, FE06, FE08, FE09, FE12)
24	IED type (FE07)
25	IED type (FE10)
26	IED type (GE01, GE03, GE04)
27	IED type (ME02)
28	IED type (TE01, TE02)
29	IED type (TE03, TE04, TE05, TE06, TE07, TE08)
30	IED type (UE01)
31	IED type (UE02)
32	IED type (VE01)
33	IED type (VE02)
40	Reset for 20 to 33 commands

### **4.3 Safety Standard Compliance**

The purpose of this chapter is to tell how the testing system complies with the safety standards. The chapter will tell how it is protected from electricity and how this affects working.

#### **4.3.1 Protection against electrical shock**

This testing system has been protected in accordance with safety standards to make it safe to use. The IED is sealed from the front side with aluminium plates and at rear side the wiring is protected with plexiglass. The fuse box is sealed with a cover on the front and rear side. The AC800M and the I/O modules are covered by plexiglass on the front side and on the rear side it is covered with the electrical cabinet. The DTS connection strips and relays are covered by plexiglass on the rear and front side. Arduino lies inside the electrical cabinet to ensure operational safety, because of unprotected surfaces.

#### **4.3.2 Replacing the IED**

Replacing the IED is simple and safe. The right cards only need to be replaced to the connection slot and X130 slot. Then the cable is connected with Arduino and right commands given to get the right configurations for the replaced IED. There is no need for physical changes for wiring.

#### **4.3.3 Help for using the rack**

Guidelines and the AutoCAD pictures can be found inside the electrical cabinet door. There is a plastic pocket which contains the rack documentation to help the user.

#### **4.4 Customer Friendly**

One of the aims of this project was customer friendliness. It means that the look of the testing system is decent and that the rack is safe for customer. The rear side area of the testing system is forbidden area, but it can't stop the customer getting behind the test racks. This is the reason why the rear side must be protected as well than the front side.

#### **4.5 Standardised Wires and Devices**

The purpose of the reformation was to get standardized testing system for 615 series. It means that all materials remain the same in all 615 series rack, for example wiring and location of the components. The wiring design is based on 615 manuals and the wiring was created that can be changeable automatically and there is no change for short circuits. Arduino makes the wiring changing possible with the relay circuits, but the wiring is able to work only in standard configurations.

#### **4.6 Flexibility**

The testing system is very flexible for future situations, because of the automatic wiring system, for example, -if the IED slots at the laboratory are full and there are no IED spots available for new 615 series protection relay that needs to be tested. In this situation one of the old ones can be taken off from the new testing system and Arduino can be given the commands the new IED needs. After the given configuration commands the replaced IED is ready for testing.

#### **4.7 Comprehensive Documentation**

The original rack designs do not have any documentation about wiring, circuit diagrams or layout. The new redesigned and standardised rack has circuit diagrams, apparatus list, programming data and this thesis for the clearing of documentation.

The circuit diagrams support the troubleshooting and further development. The Apparatus list supports to find the used components and devices and also the ordering process. The programming data supports also troubleshooting.

## 5 PREPAREDNESS FOR AUTOMATIC TESTING

The purpose of this chapter is to tell how the rack is more prepared for automatic testing of IEDs and how Arduino and PLC work together making the process easier.

### 5.1 Configuration Modifications by PLC/Arduino

The idea to make modifications automatic is based on AC800M and the Arduino functionality. The commanding orders from the superordinate system to the IED needed to be done by the same function block (FB) which has always been used. All orders that are given from the original FB will go through to the new FB created in this project, that gives the right path to the given order and Arduino helps with that order signal to go to the right connection pin in the IED. Figure 12 shows what program and device parts are connected to each other.

To open more this function sequence figure 12:

- The original FB handles incoming commands and transmits the data to the new FB.
- The new FB handles incoming commands from the original FB and executes DI/DO signals.
- I/O module signals go to the relay circuit that is controlled by Arduino.
- Arduino executes the given order code that is given as a serial code. The order code specifies what relays goes ON/OFF in the relay circuit.
- The relay circuit guides I/O signals
- The IED receives incoming signals from the relay circuits or straight from AC800M.

The point in this is that the new FB and Arduino makes possible that there is no need to do any physical changes to the wiring in the testing system.

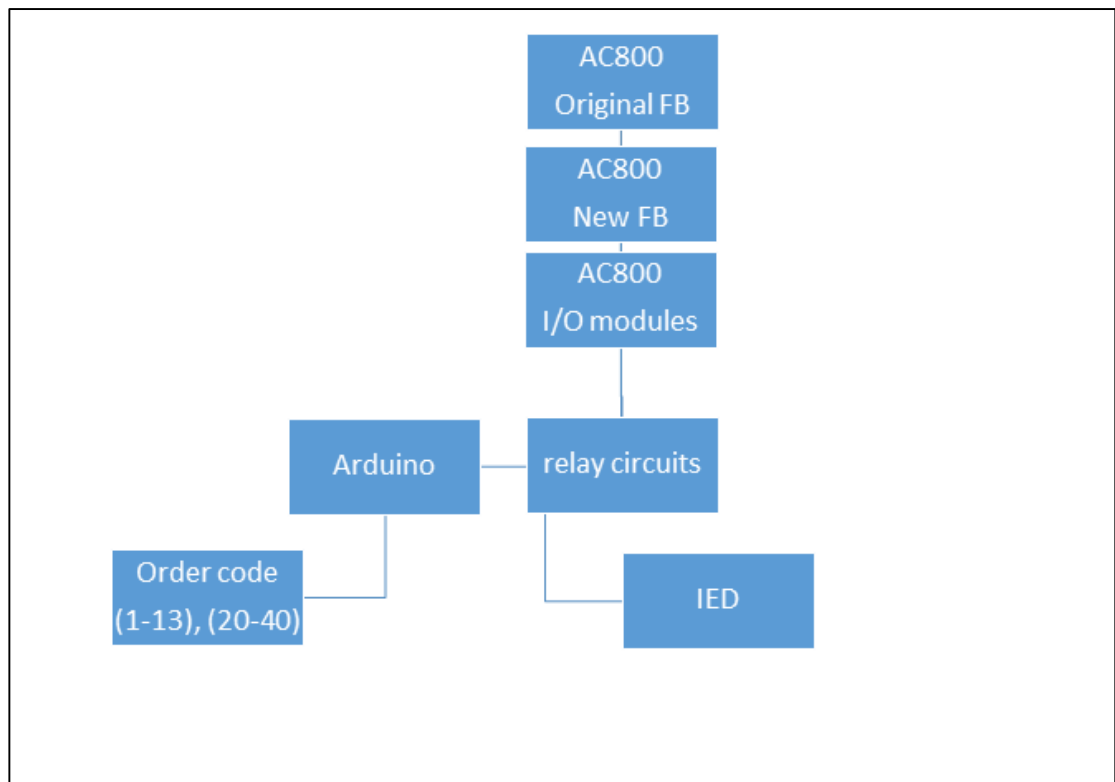

**Figure 12.** Function sequence



## 5.2 Arduino

Arduino is a microcontroller circuit that has analogy I/O, digital I/O and a development environment for writing software for the circuit. Arduino needs 12V power, but it controls the digital outputs with 5V. The program language is based on C/C++.

In this project Arduino Mega2560 (Figure 13) is used for controlling small interposing relays in the electric cabinet. One Arduino can control 32 relays and in this automation rack there are 32x4 relays, so the rack has four Arduinos in the cabinet. The rack have four IED (relays) and one IED needs one Arduino, because of 615 series variables consists of 2 x 16 relay circuits. /6/

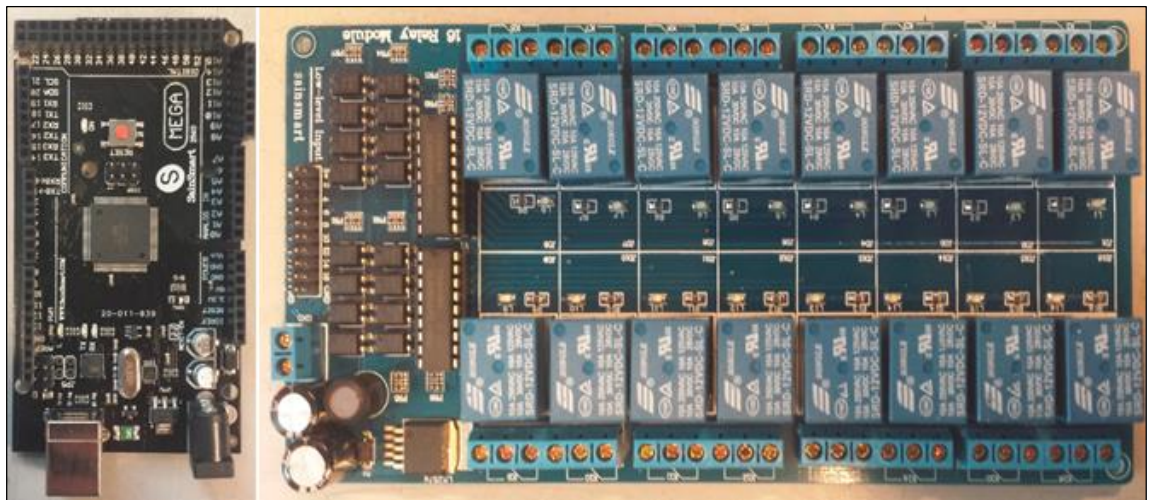

**Figure 13.** Arduino Mega2560 and relay circuit

### 5.3 AC800M Programming

The AC800M program additions were created to an existing program, because the new function block for the new testing system had to be compatible with the old program and it made it much easier, because there is no need to do the testing program from the start. The new program additions were created to the library as a function block and the task of the -function block is to guide to use the right signal for the right IED.



**Figure 14.** AC800M

### 5.3.1 New Function Block for Signal Guiding

The result of designing was to create a function block that guides to use the right I/O signals. The program includes four similar function blocks, but FBs controls the different IED. FB IED1\_connections controls the IED1, IED2\_connections controls the IED2, IED3\_connections controls the IED3 and IED4\_connections controls the IED4. The FB needs to be connected to the -original FB by commands, so the CB\_open/close, TR\_open/close and ES\_open/close inputs are connected to the original commands IEDx.Q0.OpenInd, IEDx.Q0.CloseInd, IEDx.Q1.OpenInd, IEDx.Q1.CloseInd, IEDx.Q9.OpenInd and IEDx.Q9.CloseInd as in Figure 15.

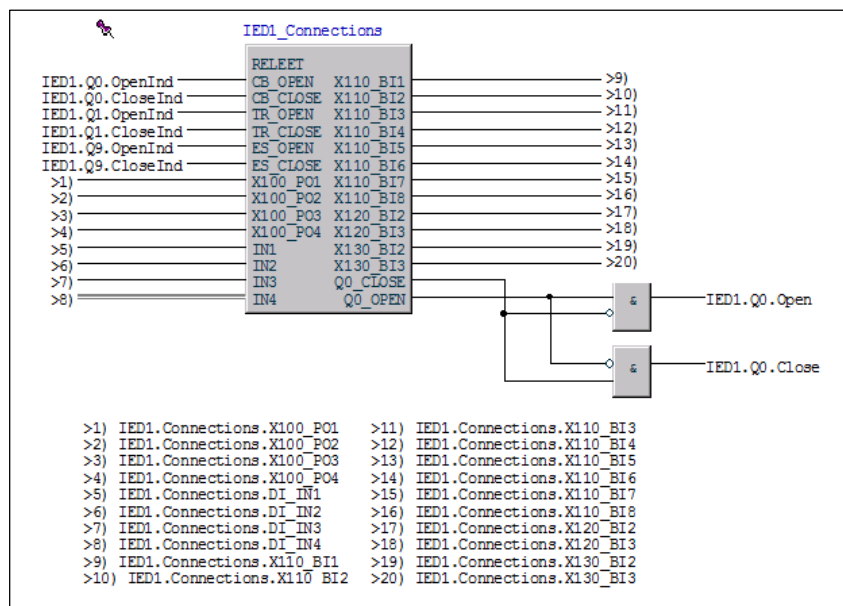

**Figure 15.** Function Block

### 5.3.2 Software of Function Block

The function block includes the terms that allow the right signals by pass the AND blocks when the right type of protection relay is activated. Figure 16 shows that AND blocks allow Open/Close signals from that block where the activated relay type is. If any of the conditions is met, the OR blocks allows signals to the binary input of the IED.

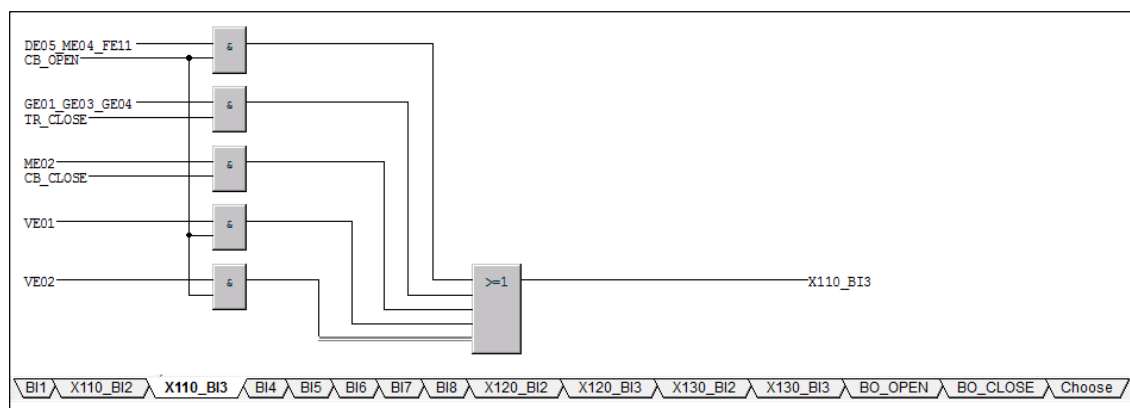

**Figure 16.** Functionality of the Binary inputs

The function block includes digital input programming that activates the right type of IED in the program. The type of IED in the program is collected from the IED manuals. All different kind of configurations create a new type of IED to the program. Figure 17 shows six different configuration types, but there are 14 different kind of the configurations. All configurations are programmed in a different way and activates the different binary inputs of the IED with Open/close signals.

The chosen IED was achieved with DI channels of the AC800M. The configurations can be activated from the program or from Arduino. Arduino controls the signals to the DI module. The terms for configurations are made with 4 inputs for every IED slot, so four slots take 16 DI signals. The given command for Arduino determines what inputs are activated. Four digital input signals can show 16 different states and the rack needs 15 of them, so there is one state open for the new IED configuration for future expansion. The 15 states generate from 14 different type of configurations and the zero state.

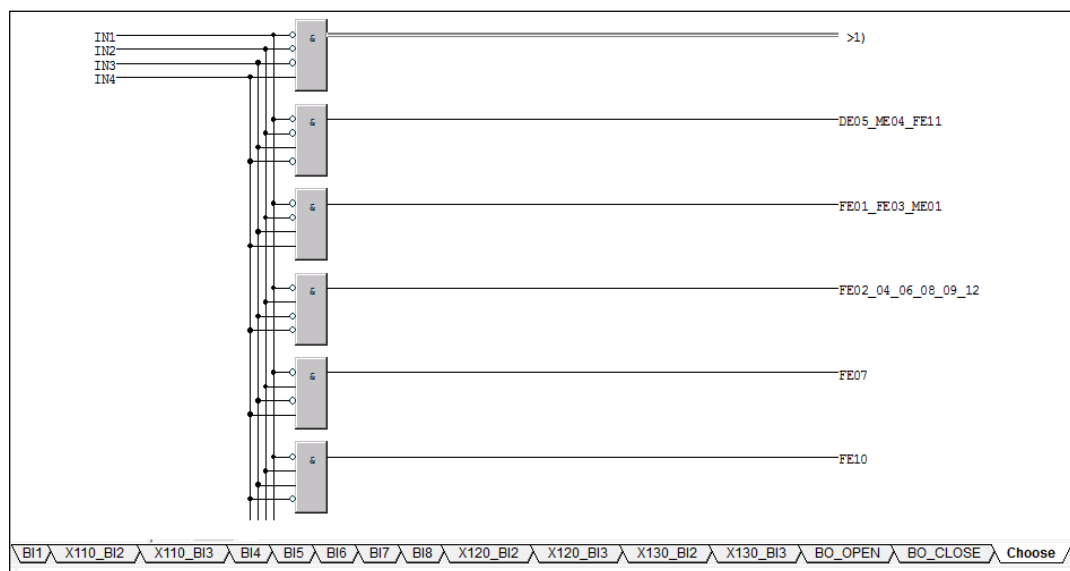

**Figure 17.** Configurations of IED

#### **5.4 Future Automatic Testing Projects**

The next step for automatic testing is to divide tasks into two projects. The first project is for research and commissioning of automatic test system which could work as a heart for automated tests. The second is to involve test functions and test itself with automation which will be integrated to the automatic test system. The objective is also to combine automation experience in ABB Oy, Medium Voltage Products to get better resources into use and improve the team spirit between departments. /8/

## 6 CONCLUSIONS

The nature of this thesis was a project and it was very educational. The first step to this thesis was getting to know different types of protection relays. There were many problems with the wiring, because the configurations were so different from each other. The PLC programming was thought over during the wiring so it was a fast part in the thesis.

The thesis started in October 2015 and it was finished in April 2016. The base studies for the thesis started already in 2015 summer, because it worked as training for the job. In my opinion the thesis and the documentation succeeded well and the testing system is ready for future testing. The idea can be used for different series relays.

The full documentation of the thesis was created and delivered to the PVC. The thesis has taught very much and it was interesting. Great teamwork with co-workers was required to succeed. The results are good, but there will be updates for the testing system. The documentation will help engineers to get familiar with this new testing system.

I developed the testing system safety, wiring and new function block for the AC800M. The objective was to get it work with the old AC800M program and add more safety to the system.

## REFERENCES

- /1/ ABB description. ABB internal website.
- /2/ ABB website. Accessed 20.1.2016. <http://new.abb.com/fi/abb-lyhyesti/suomessa/yksikot/medium-voltage-products>.
- /3/ PVC presentation. Internal ABB website. Accessed 20.1.2016.
- /4/ ABB TTT handbook 2000-07. Teaching material. Accessed 20.1.2016. [http://www.oamk.fi/~kurki/automaatiolab-rat/TTT/15\\_S%84hk%94njakeluverkon%20automaatio.pdf](http://www.oamk.fi/~kurki/automaatiolab-rat/TTT/15_S%84hk%94njakeluverkon%20automaatio.pdf).
- /5/ Arduino. Accessed 20.1.2016. [www.arduino.cc](http://www.arduino.cc)
- /6/ DE01, DE02, DE03, DE04, DE05, ME01, ME02, ME03, ME04, FE01, FE02, FE03, FE04, FE05, FE06, FE07, FE08, FE09, FE10, FE11, FE12, GE01, GE03, GE04, UE01, UE02, VE01, VE02, TE01, TE02, TE03, TE04, TE05, TE06, TE07, TE08 application manuals.
- /7/ ABB Substation Automation. Accessed 20.1.2016  
<http://new.abb.com/substation-automation/products/protection-control/relion-product-family/relion-615-series>
- /8/ Kentta, Joni. ABB. Senior Design Engineer. Interview 23.2.2016.