

Mahesh Karki

# Design optimization of a reinforced concrete slab in weak clay

Helsinki Metropolia University of Applied Sciences

Civil Engineering

Degree Programme in Sustainable Building Engineering

Bachelor's Final Thesis

03 June 2016

Author	Mahesh Karki
Title	Design optimization of a reinforced concrete slab in weak clay
Number of Pages	51 pages + 20 appendices
Date	03 June 2016
Degree	Bachelor of Engineering
Degree Programme	Civil Engineering
Specialisation option	Sustainable Building Engineering
Instructor(s)	Tapio Korkeamäki, Senior Lecturer (tapio.korkeamaki@hamk.fi) Kaista Pertti, Head of Department ( kaista.pertti@sweco.fi)
<p>The objective of this Bachelor's thesis is to design a slab in weak clay. The load bearing capacity of clay is 100kPa while slab will be a support system for municipal sewage pipe system. Due to the low load-bearing capacity of clay, it can't hold all the loads that come from the top i.e. the traffic load and the earth load. There are different methods to design a slab when there is enough load bearing capacity of soil but due to the diverse and heterogeneous nature of the soil, the load bearing capacity of soil varies and it is very difficult to design the structure when the load bearing capacity of soil is less.</p> <p>Similarly, this thesis is also part of a recommendation for SWECO Oy Finland for the design of a ground slab to support a municipal sewage pipe system in weak clay in an economic and effective way. In order to provide the support to the slab, a column with a compressive strength of 400kPa and radius of 400mm was designed using Deep soil mixing method with c/c distance of 1700mm. The value of moment and other necessary calculations were calculated using Robot Structural Analysis (FEM).</p> <p>Firstly, the slab was placed in weak clay assuming clay as a support system where the elastic coefficient of clay (<math>k_s</math>), was calculated and later the value was used in Robot Structural Analysis to calculate the moment and deflection. The deflection of the slab was very high so it was decided to provide supports to the slab using columns created from deep soil mixing method. Finally, in total, 14 columns of 400mm radius were used to achieve the suitable design condition.</p>	
Keywords	soil, slab, modulus of subgrade reaction ( $k_s$ ), deep soil mixing, robot structural analysis(FEM)

## Table of Contents

1	Introduction	1
2	Soil	2
2.1	Ground Improvement and support systems	5
3	Deep soil Mixing (DSM)	10
3.1	Compressive strength of DSM columns	14
4	Design Principles and Loads	17
4.1	Modulus of subgrade reaction	20
4.2	Load Calculation	23
5	Reinforced Concrete Slab	28
5.1	Shrinkage and Creep in a slab	29
5.2	Cracking in a slab	31
6	Finite Element Method (FEM)	34
6.1	Design Optimization	38
7	Final Design	42
8	Conclusion	47
9	References	48

### Appendices

Appendix 1. Additional Figures

Appendix 2. Calculations

## ACKNOWLEDGEMENT

I cannot express enough gratitude to senior lecturer of HAMK UAS Tapio Korkeamäki who helped me while doing research for this thesis. Working with him together in the process of writing my Bachelor's final year thesis was a great opportunity for me to learn many new things.

Similarly, I would also like to thank Head of the department of Bridge and Structural Engineering, SWECO Oy Finland, Kaista Pertti who gave me, an opportunity to write a thesis on this topic and free time from work. Likewise, I would also like to thank Jyrki, Geotechnician of Finnmap Infra Oy for his time and information regarding DSM columns.

Secondly, I am also pleased to thank senior lecturer of Helsinki Metropolia UAS Jorma Säteri for supporting me in this thesis and finally special thanks to all of my friends especially to Ardeep Maharjan for his hospitality and help during thesis writing.

- Mahesh Karki  
03 June 2016  
Hämeenlinna; Finland

## 1 Introduction

Every structure is in contact with soil, where soil acts as a support system for the superstructure and all of the loads in the structure are ultimately transferred to the earth. The soil consists of various layers and due to the diverse nature of the soil, the load bearing capacity of soil varies. Soil layers vary in extent as well as in depth, even in a small area which makes it very hard to study. As the quality of soil layer is increased then the ability of that layer to distribute the load is also increased. Typically, in Finland, most of the soil has been generated as a consequence of ice age. When the glaciers receded years ago, they left behind only typical soil that can be seen in Finland, bedrock together with quaternary deposits. (Nenonen & Portaankorva, 2009).

This thesis deals with the design of a 24m\*1.5m\*0.25m reinforced concrete slab in weak clay which has to support the municipal sewage pipes without causing any failure. Similarly, the traffic load and the earth loads will also be taken into account in the design process. The dimension of reinforcements to support the slab which would take the tension force will also be calculated. There are various complications in designing a slab due to the presence of weak clay. As the load bearing capacity of clay is very weak, the presence of static and dynamic loads makes it more complicated and challenging. Similarly, the span of the slab is 24m long which makes it more compound. Various ground slabs are being installed currently in projects in Finland but regardless of all the practical knowledge available to solve the problem, the structure continues to face the problem of deflection, cracking and shrinkage. With the deflection and shrinkage, the slab starts to crack and the structure on the top (sewage pipes) starts to break and cause various problems. The soil is neither completely flexible nor is it completely rigid. The value of modulus of subgrade reaction,  $k_s$  was calculated assuming the soil as flexible as shown in Figure 45.(See Appendix)

Initially, weak clay has to support a slab and distribute the load coming from the top to the earth. It is very difficult to make a structure in weak clay and this problem is approached in two ways. The first way is to increase the load bearing capacity of clay by using various methods as well as to provide support systems to the slab which would be discussed further. The second way is to design the slab which could hold the various loads like traffic loads and earth loads without causing any significant deflection and

cracking in the slab. Separate calculations of earth loads, traffic loads, shrinkage, and reinforcements have been made which can be studied from the Appendix 2.

## **2 Soil**

The soil is a mixture of minerals, organic material, water and air. The soil profile of one location is unique to that of another. The soil consists of various layers of sand, silt, clay and bedrock. Before discussing more about the slab design, as the slab is in the soil and soil holds the slab and transfers all of the loads to the earth that comes to the slab in its lifetime it is important to know about the soil mechanics. Typically, the top layer of the soil consists of the organic material such as decomposing leaves, the second layer is known as the top soil which consists of fertile soil, the third layer consists of sand, silt, minerals and clay as well as other various mixtures of soil. Finally, the last one consists of the rock layer which is also commonly known as bedrock. The layer of bedrock is a very good layer of foundation for any structure. Whenever the layer of bedrock is deep the piles are used to transfer all the loads to the bedrock which will make the foundation strong.

Some soil is strong and some are weak. The characteristic term used to describe the carrying capacity of soil is the load bearing capacity of soil. The load bearing capacity of soil is the property of soil which can be described as the capacity of the soil up to which it can hold the load without collapsing the structure on top of it. It is very important for the structural engineer to know the load bearing capacity of soil so that the structural engineer can design the structure in the soil. If the load bearing capacity of soil is very weak, then the structural engineer has two choices i.e. whether to install support system which can be a pile or a group of piles or to improve the load bearing capacity of soil by using various techniques. These techniques might vary according to the type of soil and on the location of the project. As already stated the bearing capacity of soil varies but the presumptive bearing capacities of various soil types is included in Figure 40.(See Appendix 2 )

Installing piles can be very expensive and the design process is very complex and time-consuming. One of the simplest ways to improve the load bearing capacity of soil is to use various techniques, but before that it is very important to know the various features of soil. It is the job of Geotechnician to provide the details of soil to the structural engineer

so that the structural engineer can design a stable structure. The design is done using the safety factor of 1.5 for live loads and 1.15 for dead loads to increase the safety limit and to control the deflection and settlements of the structure in tolerable limits. The soil consists of voids between which water and gas are present. The weight of water and soil can be calculated by using the following formulas.

$$w = \frac{W_w}{W_s}$$

$$S = \frac{V_w}{V_v}$$

Where;

$W_w, W_s$  = Weight of water and soil respectively,

$v_w, v_v$  = Volume of water and voids,

$w$  = Water Content;  $S$  = degree of saturation

Soil consists of various asymmetrical shaped particles of various shapes and sizes due to which grain soil distribution (GSD) as shown in figure 1 is used to classify various soil types. GSD is an engineering property of soil which determines soil properties which make it easy to do the soil classifications according to grain soil distribution. The soil consists of cavities or voids between particles which cause the low bearing capacity of soil. These voids are partially filled with air or water. There are various terms to describe the properties of soil in geotechnical engineering studies. Commonly used terms are void ratio “e” porosity “n” water content “w” and degree of saturation “S”, bulk weight, unit weight of soil and water. (Rao, 2011)

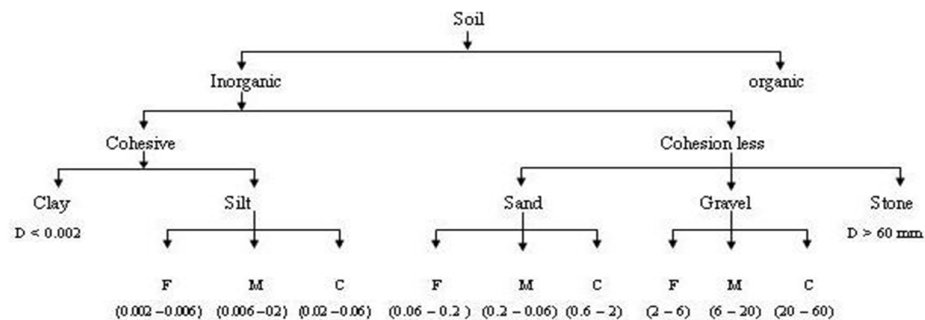

Figure 1: Soil Types with size limit in mm. (Soil Properties)

$$\begin{aligned}\delta_t &= W / V \\ \delta_s &= W_s / V_s \\ \delta_w &= W_w / V_w\end{aligned}$$

Where,

$\delta_t$  = Total unit weight;

$\delta_s$  = Unit weight of soil;

$\delta_w$  = unit weight of water. (Rao, 2011)

Further ways to calculate the above-mentioned terms can be studied in various books of soil mechanics. The existing soil at the site is not always suitable to design the structure so it is necessary to find various techniques to improve the load bearing capacity of soil. These techniques are very good as they might increase the load bearing capacity by double or more. In order to determine the types of soil present underground before constructing the structure on top of it, subsoil exploration is done. Sub Soil exploration is a process where Geo-technician investigates the character, nature, load bearing capacity, and other various characteristics of soil. Subsoil exploration is very important to determine the types of soil present underneath the soil. A sample document of subsoil exploration is included in Figure 41. (See Appendix). With the type of soil known, various experiments can be conducted to calculate the needed data that will be further used in the design process of the structure.

There are various types of soil like expansive soil which swells in water and shrinks after the removal of water content. With the subsoil exploration, the data is given to the structural engineer so that the engineer can design the proper structure. The long-term performance of the whole system depends significantly on the stability of the underlying soil. Similarly, the stability of the whole system lies on the underground slab that is placed in order to support the sewage pipeline along with other various infrastructures like water pipelines, rainwater collection pipes, electricity lines, internet lines and other various communication lines.

After the subsoil analysis, the various properties of soil are known and those properties can be used in various ways to increase the bearing capacity of the soil if it is weak. Some common methods of ground improvement are described in further chapters. Sometimes the analysis is just skipped if the characteristics of the soil are well known.



From the analysis Geotechnician knows about the rock condition, load-bearing capacity of the soil, ground water conditions and other valuable data. The soil is classified as cohesive and cohesionless soil. The cohesive soil is the fine-grained soil which is closely integrated and stick together. The particle size of the cohesive soil ranges from 0.06mm or less. The cohesive soil is soft when it is wet and it becomes stiff when it is hard which causes a high amount of shrinkage and swelling in the soil. Cohesive soil like clay cannot be compacted easily. A process like static pressure and kneading is done for the compaction of cohesive soil. Several layers of gravel and other materials are placed to increase the bearing capacity of the soil before placing any structure on the top of the weak soil. Cohesion soil can be sand; gravel stone whose particle size ranges from 0.06mm to 200mm or more as shown in Figure 1.

As this thesis deals with the design of structure in clay, it is necessary to know about clay. Clay is a fine-grained soil or natural rock material which consists of various clay minerals. Due to the presence of water content clay can be found in a wet condition which behaves as a plastic in nature. Clay becomes hard when water is removed from it but it becomes brittle too. Clay can be considered as a very good construction material or very bad depending on the water content. If there is expansive or heave clay, then it causes problems to the structure. There will be a structural damage on the structure if the water content changes on the soil as a change in the water content will cause the shrinking or swelling in the clay.

## 2.1 Ground Improvement and support systems

The ground improvement process has various meanings in the construction industry. Typically ground improvement means making the soil strong by various methods to enhance the physical and chemical properties in order to increase the compressive strength of soil and to reduce the bad properties of soil like shrinkage, swelling and consequently improving the load bearing capacity of a subgrade soil to provide an efficient support to the superstructure. Since clay has a low load bearing capacity it is important to increase the bearing capacity of clay so that it will act as a support for a slab and other various civil infrastructure. Clay is the most problematic material to be dealt with because of its properties of swelling in a wet environment and shrinking and drying in a dry environment. The terminology used for the soil support systems is different in various books. The definition given by the American Concrete Institute is given below in Figure 2.

Subgrade: Natural soil that is already present there.

Subbase: This layer usually consists of gravel.

Base: This layer is on top of sub base and under the slab. (Concrete Network)

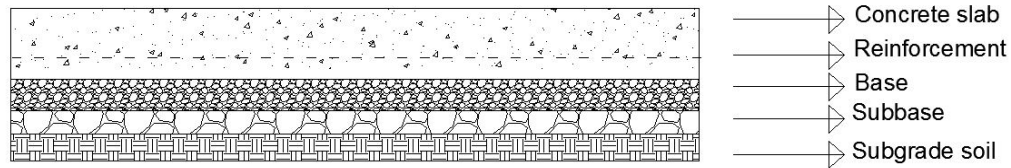

Figure 2: Typical layers of soil stabilization

One of the most frequent problems in soil is the problem related to the settlement of the soft soil and heave of the expansive soil. There are several ground circumstances where at least a reasonable increase in the bearing capacity in weak soil is desired. The soil is a very dynamic material as it varies from place to place and different techniques are needed to stabilize the weak soil. The design of slab has to be such so that it could hold the structure and transfer the loads to the ground without cracking and deflection in the substructure. The concrete slab has to provide the needed support required to achieve the acceptable performance under traffic and other various loadings. Therefore, the base should be strong enough so that it can support the whole structure and transfer the load to the ground. Similarly, if the subgrade soil is not properly stabilized it will lead to the damage of the slab by cracking and deflection. (Civil Engineering Home)

The current practice to increase the soil stability and to increase its load bearing capacity is not enough and the stabilization property varies due to the diverse and heterogeneous nature of the soil. (Powrie). One of the best methods of stabilization would be the one which would provide the durable stability at a low economic cost. Geotechnical properties of tricky soil like soft fine grained soil, clay, and expansive soil can be enhanced by various approaches and techniques. The most common method of soil densifying or soil stabilization is the use of the soil compaction method but the problem is with the clay. If there is a clay, it's hard to do the compaction. Another method should be used for the compaction of clay. The chemical method can be used to treat the problematic soil using various chemicals like lime, (Bell, 1996) , cement, fly ash or the combination of above.

Cohesive soil like clay cannot be compacted but according to the Menard and Broise, cohesive soil can be treated by the dynamic replacement method. Dynamic replacement

can improve the soil property as long as there is no liquefaction. Clay soil can be stabilized by adding a small percentage by weight of lime to enhance the properties of clay and make it more stable. According to a research by F. G. Bell in 1996 it is recommended to use no more than 8 % of lime to reduce the shrinkage and increase in the plastic limit of clay. Lime stabilization is very useful for clay as it reduces shrinkage and swelling and increases the compressive strength by noticeable times in many cases of soil. (Quality Lime and Stone Products) The use of compacted coarse aggregate like gravel, crushed rock, natural or crushed stone also provides the structure stabilized the base. The properties of the soil can be changed by using various methods like surface compaction and consolidation. Similarly, methods like Vibro replacement, soil reinforcement, the use of geotextiles and geomembranes, deep soil mixing, and piles are also used to support the structure which is discussed below. (Civil Engineering Home).

### Vibro replacement

Vibro replacement is a technique where a dense aggregate column is constructed by a means of a crane suspended downhole vibrator as shown in Figure 3. It is also commonly referred to as Vibro compaction. This technique helps to improve the soil bearing capacity and decreases the settlement. This method of soil improvement technique creates a high modulus of the stone column that reinforces the treatment zone and densifies the surrounding granular soil. (Hayward Baker)

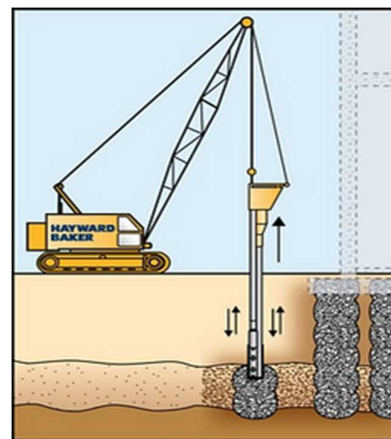

Figure 3: Vibro Replacement (Hayward Baker)

It is possible to make a stone column of a diameter measuring about 150 to 1100mm. This method is considered as a cheap and effective way of increasing the bearing capacity of soil when there is weak soil. The first guidelines for Vibro replacement were published by Germany where the use of Vibro replacement in a soil is restricted which has a shear strength less than  $15\text{kN/m}^2$  to  $25\text{kN/m}^2$ . (Heinz) Columns made by the Vibro replacement method are for the ground improvement but it can also be considered for the structural support which depends on the surrounding soil condition.

## Soil compaction and consolidation

Compaction is the process of pressing the soil together and removing air from voids while the consolidation is the process of removing water from voids. With compaction and consolidation, there is a significant increase in the shear strength and ductility of soil. Compaction and consolidation even help to decrease the permeability of the soil. As previously stated soil consists of gas and water, when it is compacted the load bearing capacity of soil is increased which leads to the strong foundation due to the decrease in the size of the voids. As the space between the soil is decreased thus, the bulk density of soil is also increased. The new layer can be taken to the laboratory to test its characteristics. But every soil type cannot be compacted which will lead to another method to increase the load bearing capacity of soil. Typically, clay has a lower bulk density and it's not a good idea to use compaction for clay. Therefore, piles can be used to increase the load-bearing capacity.

There are various ways for the compaction of soil like Vibro compaction, dynamic compaction, compaction grouting etc. A compaction vibrator is a method where the ground is improved using a downhole vibrator and gravel is powered from the top. Dynamic compaction is a method where a controlled heavy weight is dropped from the top of a crane which densifies the soil. Similarly, compaction grouting is a process where sink holes and voids are removed by the staged injection of low-slump, low mobility aggregate grout.

## Piles

Piles are the major support system for a various structure that is constructed in today's era. Structures like bridges, high-rise buildings, towers, and dams, uses piles as their support systems. The pile is a vertical support structure of a deep foundation that is driven deep into the earth. The pile is kept deep in the earth and left underground in bedrock to transfer the loads. There are various types of piles that can be installed to pass the loads in the earth. Some of them are micro piles, tripod piles, sheet piles, soldier piles etc. A pile foundation consists of two main components which are pile cap and single or group of piles. The pile cap is a thick concrete mat foundation that rests on the pile that is driven inside the earth. Piles can be constructed from various construction materials like wood, concrete, steel which depends on upon the type of soil that is present on the project site.

Micro piles were considered as the first options for supporting the slab but later deep soil mixing method was preferred due to the economic benefits. Micro piles are commonly known as mini piles because of their lengths compared to the other pile systems. These piles can be of a diameter from 80 mm to 300mm. During the installation of micro piles, there is less vibration and noise which is beneficial in many cases. In the case of micro piles, most of the load is supported by the high capacity of steel elements compared to the other conventional piles.

Driving piles into the saturated clay produces a temporary disturbance in the layer and increase in pore water pressure (Lambe and Horn 1965) which might temporarily liquefy the clay but after a few days the clay gains its original strength. Not all the piles go deep inside the earth. Friction piles are the type of piles that work on a different principle than the other pile system as seen in Figure 42. In the case of a friction pile, the pile transfers the load along all the height of the pile by friction. The whole cylindrical surface of the pile works to transfer the load in the earth. (Pile Foundations)

#### Use of geotextiles or geogrid

Geotextiles are a permeable fabric that is used in the construction sector which in association with soil can be used as a filter, reinforcing, protecting material and for the purpose of a drainage. Geotextiles have a very high tensile strength and can support a heavy load, whereas the geogrid is a synthetic material that is used to reinforce the soil.



As shown in Figure 4 there is a combined geotextile and geogrid which are used to separate soil from the gravel. This method can provide a good separation layer for the materials and even allow them to transfer the forces to a larger area of soil which would protect the soil from getting damaged. When the construction is over the soft soil, the excavation has often to be done in the right depth. The use of geogrid and geotextile can often act as a good solution for the project. (Spectra Roadway improvement system)

According to a recent study, the use of geogrid and geotextiles can reduce the use of aggregates and can perform even better. Similarly, the recent study has suggested using

a two layer of geogrid would improve the bearing capacity of soil. Geotextiles can even be used to prevent the roots of plants entering inside the structure. Similarly, it is also noted that geotextiles have been used in the demolition of buildings to stop the spreading of debris. (Pbs.org)

### 3 Deep soil Mixing (DSM)

Deep soil mixing is a ground improvement technique that improves the characteristics of the weak soil or in this case clay by mechanically mixing them with concrete, lime, and other admixtures according to the soil condition as shown in Figure 5. There are two types of deep soil mixing. The first is wet soil mixing and the other one is dry soil mixing. In dry deep soil mixing, the soil is mixed with a wet cementitious binder to create soil crete while in the wet soil mixing soil is mixed with dry cementitious binder slurry. Dry mixing is preferred in the areas where there is wet soil or a very high water table and the wet mixing is preferred where there is a lower water table. (Hayward Baker).

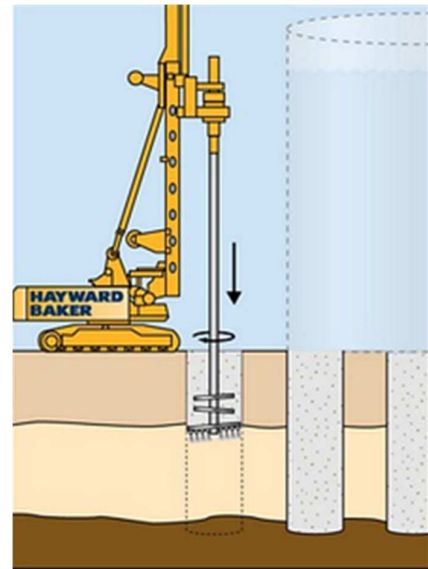

Figure 5: Wet soil mixing (Hayward Baker)

In deep soil mixing the columns, height is constructed so that they can take the load without collapsing. The columns are not constructed so that they will reach bedrock, instead, they are constructed till a stiff layer of soil. According to many researchers, deep soil mixing technique has been successful in various projects in Scandinavian countries.

In Finland, there are guidelines on how to design deep soil mixing columns but they are only for the compressive strength of 200kPa columns and the maximum traffic loading is only 10kPa. In this method, a column is constructed with a powerful drill which is passed deep into the soil and is mixed with radial paddles located near the bottom of the drill. This technique helps to increase the bearing capacity, decrease settlement and increase the global stability and provides supports for the structure planned. Wet soil mixing is a very economical and cheap choice for simple structures. (Hayward Baker)

Typically, the diameter of the column can vary from 0.6m to 3 m and the length of the column can vary from 1.5m to 10m. Similarly, there can be a single or a group column as seen in Figure 11. The diameter and the length of these columns can be decided by the structural engineer depending upon the soil conditions. As stated above it is the job of the Geotechnician to provide the details of soil conditions to the structural engineer. These deep soil mixing (DSM) columns can have circular or triangular arrangements as shown in Figure 6 and the spacing can be found out using formulas below. (Puppala, 2008)

The diameter and the length of the column created depends upon the concrete and water ratio which would also determine the strength of the columns. Before construction, the test can be conducted in the laboratory to find the suitable strength of columns so that proper diameter and length of the column can be decided. Various additives like lime, cement, different colouring etc. can be added depending upon the need of the project as well as upon the soil characteristics.

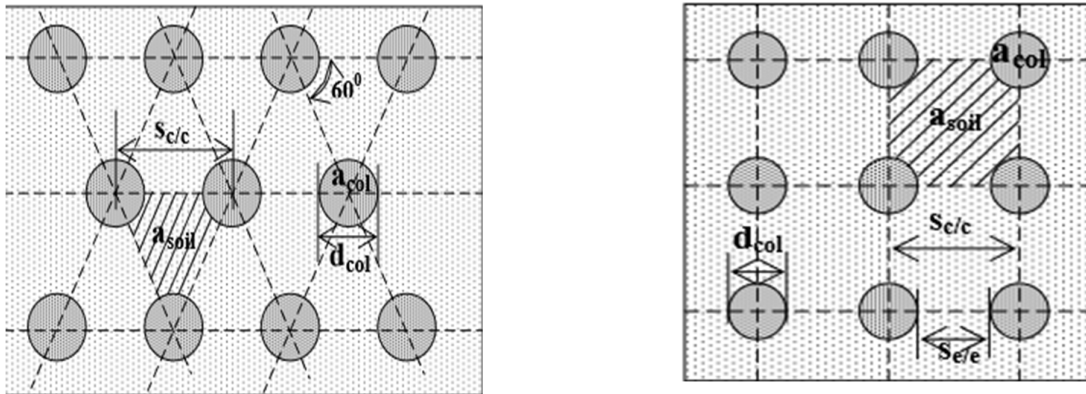

Figure 6: Triangular and square arrangements of columns. (Puppala, 2008)

For triangular arrangement,

$$\text{design area ratio } (a_r) = \frac{\frac{1}{2} a_{col}}{a_{soil} + \frac{1}{2} a_{col}} = \frac{\frac{1}{2} \text{area of column}}{\text{area of equilateral } \Delta l_e} = \frac{\frac{1}{2} \left[ \frac{\pi d_{col}^2}{4} \right]}{\frac{1}{2} * s * \frac{\sqrt{3}}{3} * s}$$

$$s = \left[ \sqrt{\frac{\pi}{3.364 * a_r}} \right] * d_{col}$$

For square arrangement,

$$a_r = \frac{a_{col}}{a_{soil} + a_{col}} = \frac{\text{area of column}}{\text{area of square}} = \frac{\left[ \frac{\pi d_{col}^2}{4} \right]}{s * s}$$

$$s = \left[ \sqrt{\frac{\pi}{4a_r}} \right] * d_{col}$$

The dimension of the slab is 24m\*1.5m\*0.25m. The initial spacing was calculated to be of 1280mm for the triangular arrangement with 20% of area ratio. Figure 7 below shows the spacing and area ratio graph which would make it easier to determine the spacing and area needed for the project according to the diameter of the columns. The strength of these columns has to be determined and confirmed in the laboratory too.

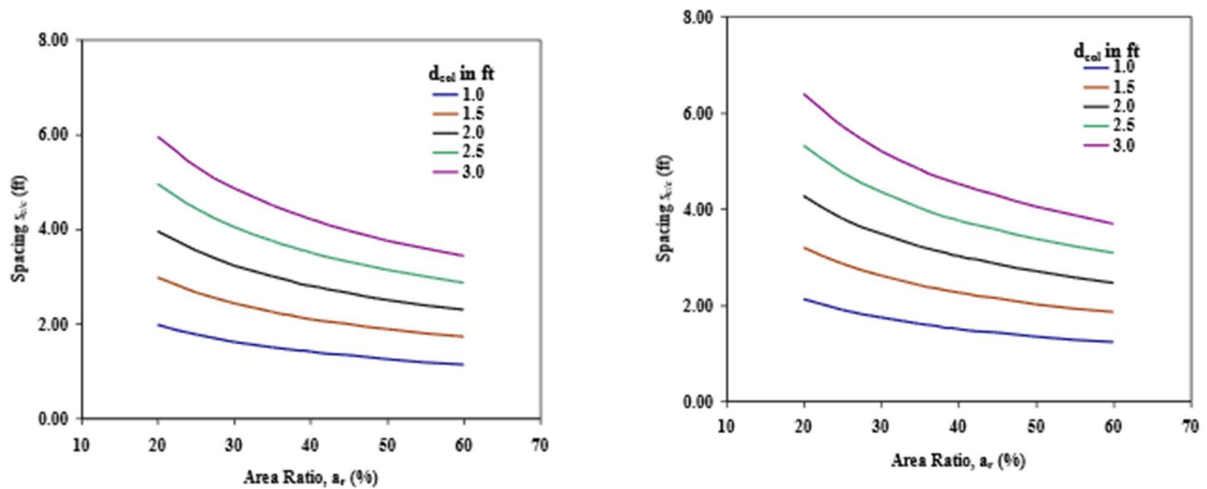

Figure 7: DSM column spacing for square and triangular pattern respectively (Puppala, 2008)



Consistency	$q_u$	
	kN/m <sup>2</sup>	ton /ft <sup>2</sup>
Very soft	0–25	0–0.25
Soft	25–50	0.25–0.5
Medium	50–100	0.5–1
Stiff	100–200	1–2
Very stiff	200–400	2–4
Hard	>400	>4

Figure 8: General unconfined compressive strength of clay. (Binod Tiwari, 2008)

In Figure 8 the required value of general unconfined compressive strength is present which can be used to get the shear strength of the column. The strength of the column depends upon the diameter and clay-water concrete ratio. With the increase in water, ratio compared to the concrete, compressive strength of column decreases. With the increase in the concrete content in the construction phase, the higher strength columns can be created.

In order to determine the number of columns, following formulas can be used:

$$\text{No of columns along the length of the slab; } N_l = \frac{L+S_{e/e}}{s_{c/c}}$$

$$\text{No of columns along the width is given by; } N_w = \frac{B+S_{e/e}}{s_{c/c}}$$

Where;

L is the length of the slab

B is the width of the slab

$s_{c/c}$  is the centre to centre distance as shown in Figure 6.

$S_{e/e}$  is the distance from the edge to edge of the column as shown in Figure 6. (Puppala, 2008)

From the calculation the initial predicted  $N_l$  is 19 and the  $N_w$  is 1. The predicted plan and the sectional views for the deep soil mixing columns is below:

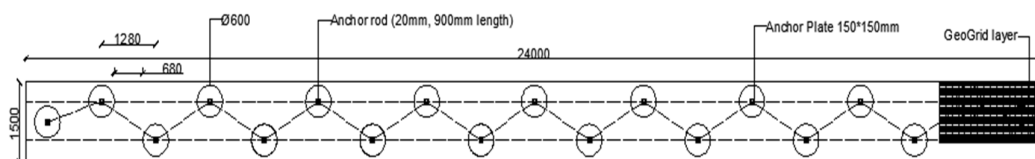

Figure 9: Initial plan view of deep soil mixing columns .

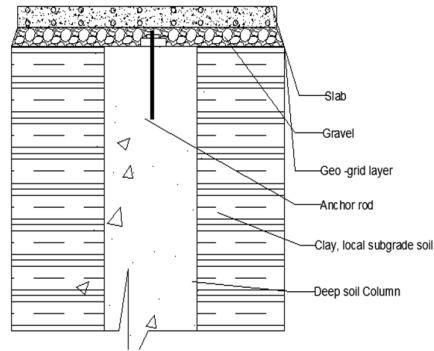

Figure 10: Initial detail view of Anchor rod and geo grid connection to the DSM column.

### 3.1 Compressive strength of DSM columns

According to Geotechnician, the compressive strength of columns that is made by DSM method can range up to 1000kPa or more with a change in water-concrete ratio. The compressive strength is very difficult to estimate and unconfined compressive strength is calculated by mix design method. Before construction, laboratory work has to be done in order to find the best suitable binder for the soil that is being treated. According to notable research team the strength properties of the deep soil mixing columns depends on the various factors like type of binders, physical and chemical properties of soil, water content, amount of binder, mixing efficiency, temperature, curing time, humidity, loading rate, confining pressure similarly on the compression, tension, and the simple shear. (Federal highway administration, 2013) The compressive strength properties of cured clay or clay crete used in the calculation are 400kPa.

Often the compressive strength of laboratory columns is more than that of the field which gives a lot of confusion on how to calculate the compressive strength of the columns. Often lots of studies have been performed and the results have been very different. According to the Euro Soil Stab the strength of the field mixed materials may be 20 to 50% strength that that of the laboratory mixed specimen while according to CDIT the strength can be 20 to 100 %. Therefore, it is highly recommended to consider the consultant of experienced DSM expert to determine the relationship between the field mixed and laboratory mixed materials.

There are some formulas for in situ method to calculate the compressive strength of the column but due to the limitation, the process on how to determine the compressive

strength of a column is not discussed in full detail. So, the compressive strength of column was taken to be of 400kPa in the calculation. Guidelines produced by Federal highway administration of US department of transportation can be used to study the methods in detail.

Column vane test was developed in Finland which makes it easy to test the compressive strength of the column in site. This test is widely used for the column of the diameter of 130 to 160mm and the height is half the diameter. This method is applicable for testing the column up to the strength of 400kPa.

As previously stated the compressive strength of column depends on the clay, cement, and water content that are used to produce the column of a fixed diameter and length. The compressive cement ratio of the grout is typically 0.9 to 1.3 by weight. The grout injection volume is typically 20% to 40% of the soil volume and the dry cement ratio to soil ratio is typically 200 to 450 kg/m<sup>3</sup>. (Kennet)

Further experiments and calculations are needed to confirm the given data by various authors as the value vary due to the change in the ratio of concrete, clay, and water. As there might be a need of various types of deep soil mixing columns, some common type of DSM columns can be seen in Figure 11.



Figure 11 : Various types of Deep soil mixing columns.

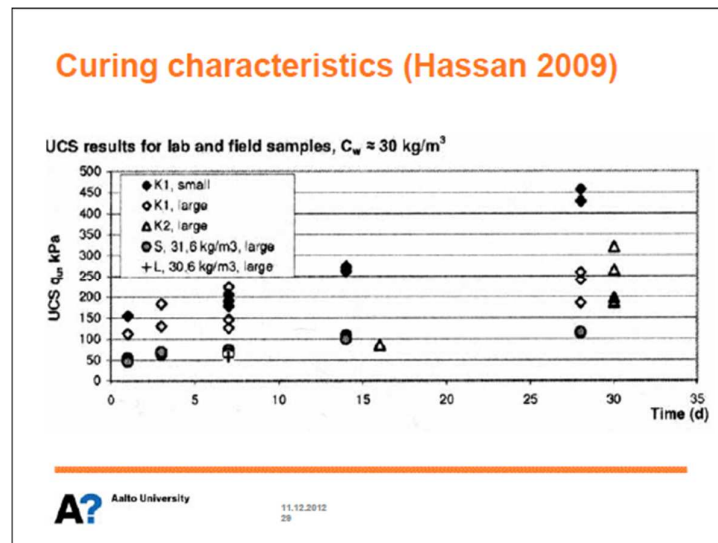

Figure 12: Compressive strength. (Korkiala, 2012)

In Figure 12 above, it can be seen that it is possible to have a strong deep mixing columns but the compressive strength of a column is very difficult to calculate using formulas. But the sample mixture can be tested in the lab several times before the construction begins to find the suitable mixture ratio of water-cement-clay for a given project. According to the recent research from the Japanese team, the efficiency of the system can be expressed in terms of the “number of mixing per yard T” as shown below:

$$T = N \left[ \frac{R_P}{S_P} * \frac{W_i}{W} \right] + \frac{R_W}{S_W}$$

Where;

$N$  = total number of mixing blades

$S_P$  ,  $S_W$  = penetration and withdrawal speed (yard/min)

$R_P$  ,  $R_W$  = blade rotation speed during penetration and withdrawal (rpm)

$W_i$  = stabilizer injection on penetration(pcf)

$W$  = Total amount of stabilizer (pcf)

From the calculation, if the value of T is  $\geq 350$  for clay then it's okay and the value of T can range from 400 to 450 for different soil types according to the research team. Similarly, there is high mobilization cost associated with the equipment. Therefore, it is beneficial to use this method in large projects than in small projects. The system becomes more strong if there are more columns to support the loads. The price of DSM columns

depends upon the number of columns and on the amount of binder as well as on the length of the column. Some price label according to Geotechnician is given below:

D600 ~ 7-12 €/m

D700 ~ 10-14 €/m

D800 ~ 12-18 €/m

#### **4 Design Principles and Loads**

Ground supported slabs is a complicated structural design area due to the complicated behavior of soil and lack of proper guidelines in Euro-Codes on how to design underground structure. There is a comprehensive source of guidelines in SFS-EN 1991-1-1 which presents a framework for establishing only a ground based structures like footings, piles, and other structures.

In Finland, ground supported concrete floors can be designed using the guidelines from 45 / BLY 7 Betonilattiat 2014. 45 / BLY 7 Betonilattiat 2014 report gives the general guidelines according to the EuroCodes as well as from the Finnish perspective. The soil in real life is neither rigid nor flexible in nature and gives a different value of soil reaction which makes it challenging to model.

Cracking of concrete should be taken into account and the consequence class CC2 is used to design the slabs. The width of cracks has to remain small enough so that it won't cause any further damage to the structure. In this case, there were several load coming from the surface to the underground slab. Dead load and live load were taken into account while calculating the soil reaction force.

It was very difficult to calculate the soil reaction force when the load case was not uniform. When the load case scenario was uniform then it is assumed that the soil reaction will be uniform on a slab which makes it easy to calculate the value of soil pressure. In real life, the soil reaction force is not uniform and various previous soil engineers or scientists have spent their whole life discovering the properties of soil.

One of the easiest ways is to calculate the deflection through the Winkler model. But the principles of the Winkler model have some irregularities. Similarly, the various structures have been designed in a conventional method assuming that the soil is rigid and the soil

pressure is uniform all the way but the scenario is different. According to the Winkler hypothesis the settlement or the displacement of the soil “ $w$ ” at a point is assumed to depend only upon the contact pressure “ $q$ ” and a proportionality constant “ $k$ ” (Straughan, 1990) as shown in Figure 13.

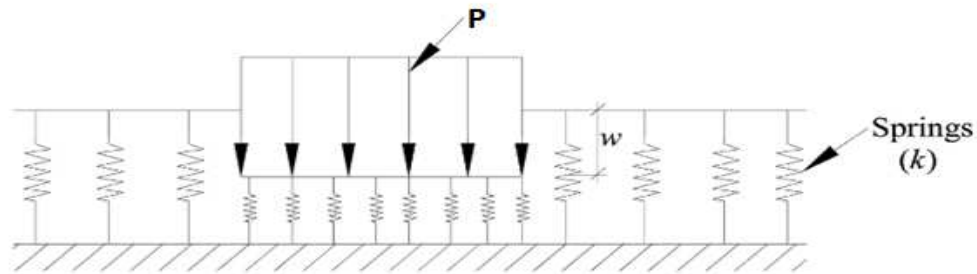

Figure 13 : Loads on Winkler Model

$$k_s = q/w; \quad q = P/A$$

Where;

$k_s$  = coefficient of subgrade reaction;

$q$  = bearing pressure;

$w$  = settlement  $w(x)$

$P$  = Load

For slab with width  $b$ , it can be written as,

$$q = bwk_s$$

The problem with the Winkler model is that the deformation of foundations is only confined within the loaded regions but the fact is that there are loads of different capacities. The spring constant  $k_s$  is different and it needs more expertise knowledge to calculate. Similarly, according to the Winkler hypothesis if soil is subjected to load, the springs will not be affected beyond the loaded region. It can be done assuming it is the same all the way but it is not which is a conventional method. The more realistic approach is to model the soil by using the elastic foundation model as shown in Figure 14 and Figure 15 but it

is more complicated and requires more in-depth knowledge on how to calculate the true nature of soil and to find the soil interaction value of  $q$ .

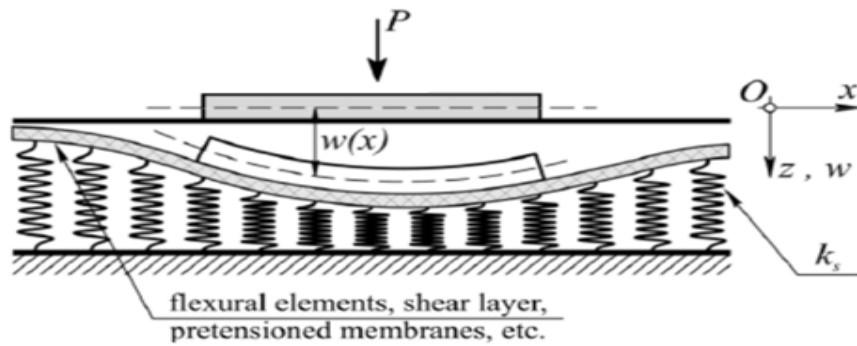

Figure 14: Loads on Elastic Foundation.

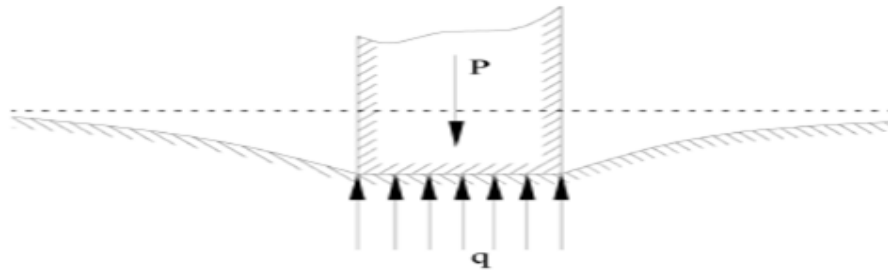

Figure 15: True behaviour of soil on loading.

In 1961, Vesic proposed an expression for  $k_s$  in terms of  $E_s$  and  $\nu_s$  (of soil) as Bowles 1996 which can be expressed as:

$$k_s = \frac{1}{B} \left[ 0.65 * \sqrt[12]{\frac{E_s B^4}{I_f E_f}} \right] * \frac{E_s}{1 - \mu_s^2}$$

Where;

$B$  = width of the footing

$I_f$  = moment of inertia of the cross section

$E_f$  = modulus of elasticity of the footing

$E_s$  = Modulus of elasticity

$\mu_s$  =Poisson's ratio

#### 4.1 Modulus of subgrade reaction

Everything in this universe changes its shape when the force is applied and soil is not an exception. When force is applied from the top of the soil, it changes its shape and soil shows a wide range of possible mechanical behaviour which determines its use for various purposes in the construction of various structures. When the structure is placed on a soil, all the loads are transferred through the soil, therefore, it is important to make a stable base ground so that base can carry all the loads coming from the structure without causing any failure to base and structure.

Since the soil displays very difficult behaviour when subjected to a load, its behaviour is very difficult to model. But the simplest representation is given by the Winkler model assuming pressure exerted at a specific point by soil is proportional to the displacement of soil at that point as shown in Figure 13. The Winker model has a limitation as the model doesn't reproduce the characteristics of a continuous medium. Therefore, the reaction of an elastic, slab or beam resting on an elastic foundation as shown in Figure 14 and Figure 15 has been an interesting structural engineering problem. (Celep, 2007)

The various software could be used to determine the deflections in a very precise manner by using a continuum, Winkler, and shear model but due to the limitation of bachelor's thesis, it will not be discussed further. To construct a huge structure soil-structure interaction (SSI) is done where the need to study the real behaviour of subgrade soil is much higher. The structural engineer can often use precise software where the structure is modelled in detail but the subgrade is poorly described which might cause various problems in the future. (Celep, 2007) Therefore, the need to see the true behaviour of soil is higher in the construction industry. But as stated above due to the limitations of the thesis only a simple case is taken and the problem is solved by using simple equation



$k_s = q/\delta$ . Further calculations have been done to calculate the value of  $k_s$  which can be studied from Appendix 2.

The word modulus of subgrade reaction tells the contact pressure underneath a foundation with settlement caused by the load. It is the ratio of bearing pressure to the settlement. Engineers are often confused with this term with load bearing capacity of soil. But these are two different terms. The load bearing capacity of soil is something that the load which soil can carry before it is being damaged while the modulus of subgrade reaction is the ratio of pressure vs settlement. (Lewis, 2007)

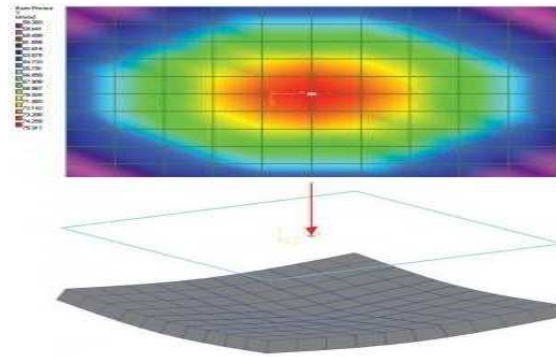

Figure 16: Soil contour. (Tribedi, 2013)

The most important factor is to calculate the allowable settlement in soil. Normally, in a small slab, there is a shear failure and with the big loads the settlement failure. The settlement failure and allowable settlement have to be calculated and if there is more settlement than the allowable settlement then there is a slab failure.

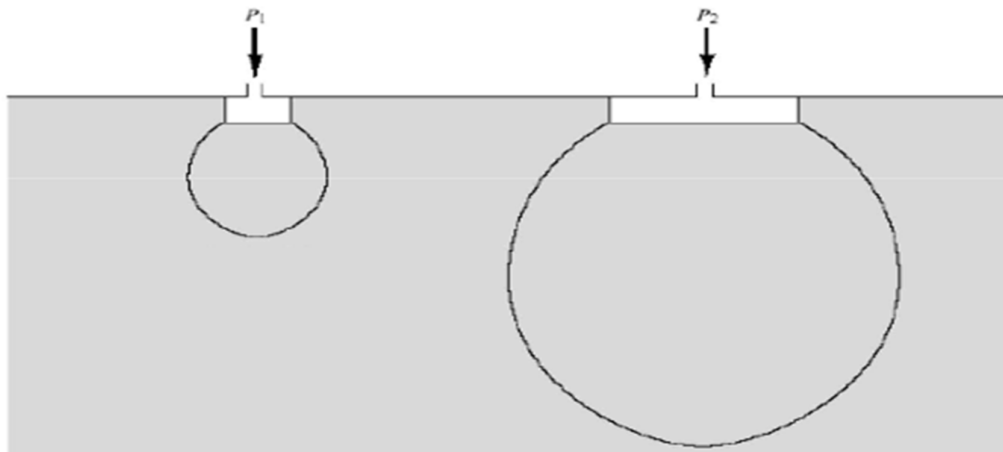

Figure 17: Soil pressure distribution on loading in two different slabs with different force.

The modulus of subgrade reaction is used to design a flexible slab while a rigid foundation can be safely designed using bearing capacity. Even though in slab there are many load points and other difficulties, the soil is considered to be flexible to calculate the soil pressure contour and settlements. The final calculation can be seen in Appendix 2.

Determining the coefficient of subgrade reaction is not a straightforward process as the depth of the loaded area below the ground surface depends on the force that is coming from the top. The wide slab will settle more while on the other hand the narrow slab will settle less as more soil is mobilized by the wide mat which can be seen from Figure 17. The value of  $k_s$  can be found by carrying out an in-situ plate load test as the soil is a variable material or by relating it to the elastic foundation. The test setup for the load test is shown in Figure 18.

For the test, a test pit is laid up to the depth where the foundation is supposed to be laid. The bottom width of the pit is five times more than the width of the foundation and at the center of the pit, a hole is made whose size is equal to the size of a plate. The plate should not be less than 25mm and its length varies from 300mm to 750mm. Circular or square plate can be chosen according to the choice of the foundation. After the setup, the load is applied from the top and the corresponding settlement is noted in a computer. Nowadays, a heavy crane is used to apply the loading from the top as seen in Figure 43.

The settlement for the cohesive soil is more and quick due to the low bearing capacity while the denser soil has more bearing capacity and more loading is required for the more settlement. After that, the required value of  $k_s$  and other necessary data from the formula can be calculated.

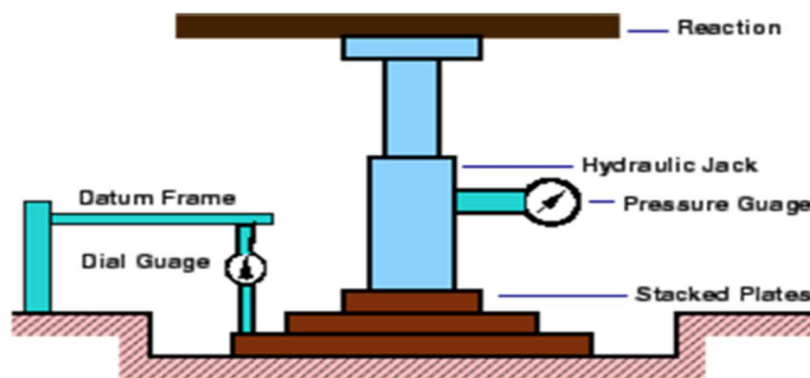

Figure 18: Plate load test setup. (Chandra, 2014)

During the experiment, the value of  $k_s$  depends on upon the size of the plate and the breadth of a beam that is resting on the elastic subgrade. Jones confirmed in 1997 that with the increase in the breadth of the slab the value of  $k_s$  decreases. The common values of  $k_s$  corresponding to the plate area of 10 m<sup>2</sup> for different soil types are given below:

Table 1: Typical value of  $k_s$

Soil Type	Permissible pressure (kN/m <sup>2</sup> )	$k_s \cdot (10^2)$ (kN/m <sup>3</sup> )
Gray plastic Silty clay with sand and organic salt	98	137.34
Brown saturated silty clay with sand	147.15	196.20
Weak soil (clay, silty clays with sand in plastic state )	Up to 147.15	(98.1 – 196.2 – 294.3)

(Rao, 2011, p. 159)

Following calculated value was obtained for the 24m\*1.5m\*0.25m slab. The detailed calculated value of  $k_s$  can be studied from Appendix 2. The average value of  $k_s$  is,

$$k_{s,avg} = \frac{k_{s,center} + 4k_{s,corner}}{5} = \frac{1016 + 4 * 1650}{5} = \frac{1523.2 \text{ kN}}{\text{m}^3}$$

#### 4.2 Load Calculation

The loads are generally categorized as vertical loads like dead load, live load and horizontal like winds load. Dead loads are permanent loads which are transferred from the structure through the lifespan of the structure. The self-weight of the structure is considered the dead load. In this case, the weight of the soil above the slab is dead load and the weight of different pipes are not taken into account as they are too small. On the other hand, live loads are those kinds of loads that are produced by the impact and they change over the course of time. Sometimes there is a huge live load and sometimes there are small live loads depending upon the condition of the traffic.

For example, in this case, the traffic loads are the live loads. These traffic loads depend on the load of the traffic that is moving on the surface. Loads due to the road traffic,

containing cars, lorry, and special industrial vehicles give rise to the horizontal, static and dynamic forces. They depend on upon various factors like the average of vehicles per year, jam frequency etc. Sometimes there can be a huge truck carrying big loads or sometimes small vehicles. Loads can be categorized as follows:

Dead loads: Earth Load, Self-weight of slab

Live Loads: Traffic Loads

Not considered: Weight of various pipes and other structures.

The traffic loads in the EuroCode is calculated by determining the pattern of the wheels. Traffic loads are put under two categories in EuroCodes “F” and “G” in Table 6.8 in Eurocode1991-1-1:2002 as shown in Figure 44. Category F is for the gross vehicle weight of  $\leq 30\text{KN}$  while the category G is for the vehicle more than 30 KN and less than 160 KN of weight.

The recommended values for the uniformly distributed traffic load ( $q_k$ ) and characteristic traffic loads value of a variable concentrated load ( $Q_k$ ) can be found in Table 6.8 in EuroCodes 1991-1-1. (European Standard Institution, 2004). Figure 19 consists of the total load diagram which shows the various load distributions over the slab. The load distribution calculations can be studied in the Appendix 2.

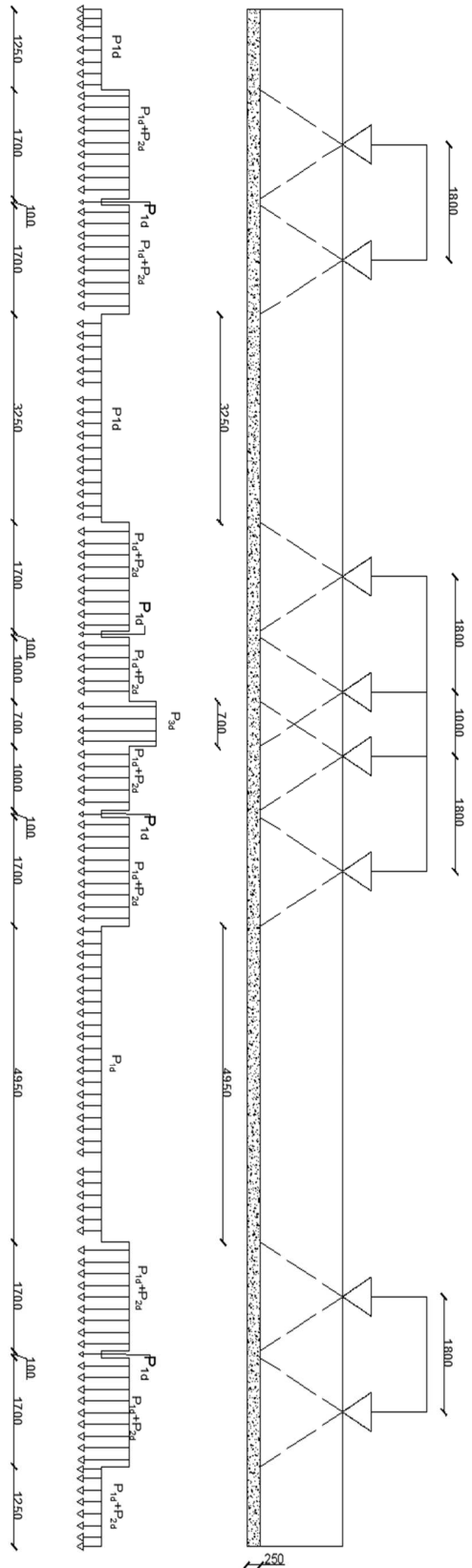

Here,  
 $P_{1d}$  = 60kN/m; Earth and self-weight  
 $P_{2d}$  = 40 kN/m; Traffic Load  
 $P_{3d}$  = 140 kN/m; Combined Load

Figure 19: Load Diagram of 1,5m\*24m slab in depth of 1,5m from surface.

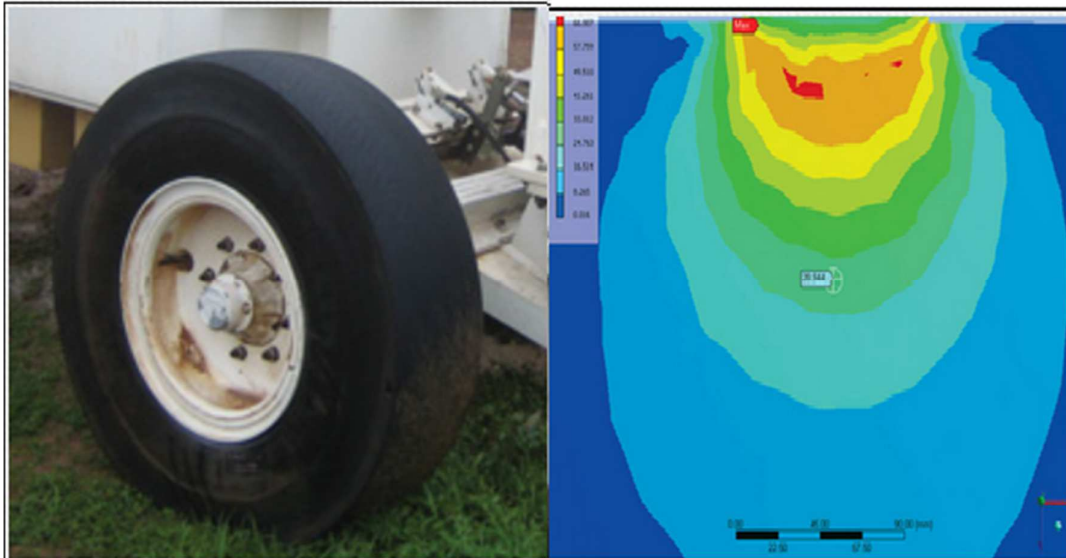

Figure 20: Soil Behaviour on traffic loading. (Renwick, 2008)

In Figure 20 the analysis performed by Renwick in 2008 is present which shows the representation of traffic loading. According to the calculation, the total dead load combining the self-weight of slab and the weight of earth above the slab was  $60\text{kN/m}$  which is represented as  $P_{1d}$  and the traffic load below  $1.5\text{m}$  from the ground below is  $40\text{kN/m}$  which is represented as  $P_{2d}$  which can be seen in Appendix 2.

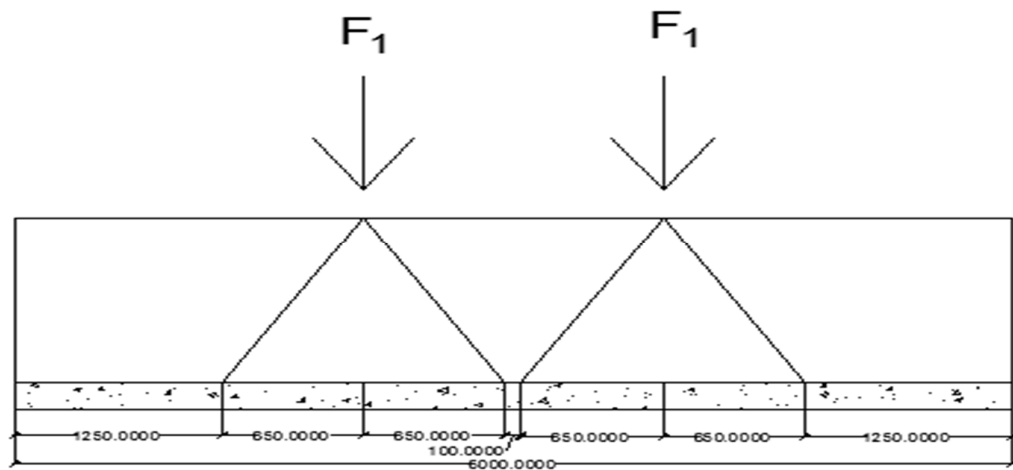

Figure 21: Distribution of Traffic Loads over 6 m of the slab.

In this case, the total load “F” was taken to be  $90\text{ kN}$  from the category Q of EuroCode 1991-1-4:2002 (E) which can be seen in Figure 44. From calculation,  $F_1$  is  $45\text{kN}$  in the

surface as seen in Figure 21 for a 6m slab. The same logic was used to distribute the traffic loads for the 24m slab. The total design traffic load that the slab receives at a depth of 1.5m is 40kN/m as shown in appendix 2. The axle load is applied on two square surfaces within 200mm side which are the loading area as seen in Figure 44. Similar further calculations were done in a ratio of 2:1 at the depth of 1.5m for the 24m long slab in various loading cases and the final result for the 24m underground slab is as shown in Figure 19.

There was a decrease in the traffic loads when the depth was decreased and at the ground level of -1.5m the calculated design total traffic load was:

$$\text{Design traffic load } (-1.5\text{m}) = 1.5 * \left[ \frac{45 \text{ kN}}{0.5 * 1.5\text{m} + 0.2\text{m} + 0.5 * 1.5\text{m}} \right] \sim 40\text{kN/m}$$

The load in 6 m slab is applied and denoted as  $F_1$  in two points of the slab which are at a distance of 1.8m. Common load case is calculated when there are two vehicles which are present at a distance of 1m for 24m slab as seen in Figure 19.

While in case, of the dead load the weight of a slab and the earth load coming from the top was also calculated which was 60kN/m.

$$\begin{aligned} \text{Design earth load + selfweight} &= 1.15 \left( 1.5\text{m} * 0.25\text{m} * 25 \frac{\text{kN}}{\text{m}^3} + 1.5\text{m} * 1.5\text{m} * 19 \frac{\text{kN}}{\text{m}^3} \right) \\ &\sim 60\text{kN/m} \end{aligned}$$

## 5 Reinforced Concrete Slab

With reference to the data from the geotechnical survey, the Geo-technician can report the ground condition which can be weak or strong. If the soil cannot hold the structure due to the low load-bearing capacity of the soil, then the engineer designs the structure according to the necessary designs so that the construction will work perfectly. Due to the insufficient load bearing capacity of soil and high values of the settlement engineer can decide to put a spaced pile to transfer the load to the ground.

Concrete is a mixture of cement, sand, water, gravel and other aggregates. Sometimes various admixtures are also mixed in the mixture to increase its hardening time, toughness etc. The most common type of cement that is used is Portland cement but the type of cement might vary depending upon the various environment factors. The durability of the concrete slab also depends on the presence of minerals in the soil that will also deteriorate the concrete. The deformations of concrete mainly depend upon the composition of aggregates. Where pile supported slabs are used, the long-term support to the slab is assumed to be solely done by the piles themselves and not by the sub-base soil. The typical type of cement used is C30/37 and it might vary depending on the soil conditions. The strength of concrete increases in time and achieves its full strength in 28 days from the curing date. (European Standard Institution, 2004)

Reinforcement in concrete is very important and nowadays it is used in almost every structure that is being built e.g. bridges, buildings, skyscrapers, homes, warehouse, foundations, roads, tunnels, dams, powerhouse, nuclear power plants, etc. Reinforcements are also considered an environmentally friendly material as it can be used again after recycling. (Concrete reinforcing steel institute)

Concrete has a very good compression strength but it can't take any tension. To counteract this defect of concrete, it is cast with rebar's to carry the tensile loads of a structure. Concrete can take at least ten times more compression than tension. (Morgan, 2015) Reinforcement is an important component of reinforced concrete and mostly steel is used as a reinforcement material. Now in AEC industry, most of the construction is done with reinforced concrete structures with various construction components like slabs, walls, beams, columns, foundations, and frames etc. (Curl, 2000).



There are various benefits of using reinforcement in concrete which is listed as follows:

- Transfer the interior tensile forces.
- Regulator Flexural cracking, direct tension cracking.
- Transmit compressive forces
- Deliver restraint toward bars in compression.
- Bound extensive long-term deformation. (Gilbert, 2012)

The reinforcement details are calculated with reference to EuroCode 1992-1-1:2004 (E).

There can be various problems that can occur in the slab which is discussed below.

### 5.1 Shrinkage and Creep in a slab

Shrinkage or drying shrinkage is the reduction in the volume of concrete due to the loss of water. There can be several cracks on the floor of the slab if shrinkage is not taken into account. Shrinking can lead to other various defects like the curling effect. This could lead to the decrease in the load carrying capacity and various joint stability problems. Shrinkage is determined by the numerous aspects which depend on upon the properties of several components like the mixing manner, the amount of moisture while curing, dry environment and member size. Similarly, the size of aggregate and the cement type have individual characteristics backing the concrete contraction or shrinkage. (The California Producers Committee and Volume Change and Affiliated Technical Organizations)

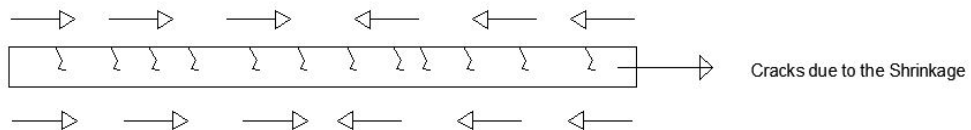

Figure 22: Shrinkage and cracks in a slab

According to EuroCode, the shrinkage and creep are time-dependent properties of concrete and their properties are taken into account for the serviceability limit state. Creep and shrinkage are influenced by the maturity of the concrete when the load is first applied and they depend on the period and scale of the loading. The ultimate limit state stability

is considered depending upon the effect of the ductility and rotation capacity of the elements. (European Standard Institution, 2004, p. 32)

According to the EuroCode 1991-1-1:2004 (E) for the calculation of shrinkage there are two components that have to be taken into account. The drying shrinkage strain and the autogenous shrinkage strain. The drying shrinkage develops slowly and the autogenous shrinkage develops during the hardening of the concrete. Hence, the value of shrinkage strain  $\epsilon_{cs}$  is given by (European Standard Institution, 2004, p. 32)

$$\epsilon_{cs} = \epsilon_{cd} + \epsilon_{ca}$$

Where,

$\epsilon_{cd}$  = drying shrinkage strain

$\epsilon_{ca}$  = autogenous shrinkage strain

$$\epsilon_{cd} = \beta_{ds}(t, t_s) * k_h * \epsilon_{cd,0}$$

$$\beta_{ds}(t, t_s) = \frac{(t - t_s)}{(t - t_s) + 0.04 \sqrt{h_0^3}}$$

Where,

$t$  = age (in days) of the concrete at the moment considered.

$t_s$  = is the age of the concrete (days) at the beginning of drying shrinkage (or swelling), normally this is at the end of curing.

$h_0 = \sqrt[2]{A_C/u}$  the notional size (mm) of the cross-section.

$A_C$  = Concrete cross section area.

$u$  = perimeter for the part of the cross-section exposed to drying.

$k_h$  = is a coefficient depending on the notional size of  $h_0$  according to the Table 1.

$\epsilon_{cd,0}$  = Nominal unrestrained drying shrinkage from Table 2.

Table 2: Values of  $k_h$

$h_0$	$k_h$
100	1,0
200	0,85
300	0,75
$\geq 500$	0,75

Table 3: The value of  $\epsilon_{cd,0}$  for different strength classes and ambient relative humidity.

$\frac{f_{ck}}{f_{ck, cube}}$ (MPa)	Relative Humidity (%)					
	20	40	60	80	90	100
20/25	0,62	0,58	0,49	0,30	0,17	0,00
40/50	0,48	0,46	0,38	0,24	0,13	0,00
60/75	0,38	0,36	0,30	0,19	0,10	0,00
80/95	0,30	0,28	0,24	0,15	0,008	0,00
90/105	0,27	0,25	0,21	0,13	0,007	0,00

The final autogenous shrinkage is calculated from,

$$\epsilon_{ca}(\infty) = 2.5(f_{ck} - 10)10^{-6}$$

Finally, total shrinkage was calculated to be  $2.86 \cdot 10^{-4}$  mm. The detail calculation is included in appendix 2.

$$\epsilon_{cs}(t) = 4.89 \cdot 10^{-5} + 2.38 \cdot 10^{-4} = 2.86 \cdot 10^{-4} \text{mm}$$

## 5.2 Cracking in a slab

In Figure 23, cracks can be seen in the slab. There can be various reasons like excessive stress in the slab, shrinkage and creep cracks due to unstable soil, use of less reinforcement, use of improper admixtures, an improper mixture of cement, aggregates and sand, or due to heave in the soil etc. These cracks can make the whole structure unstable and can cause the leakage in the pipes. With the leak, there will be a dangerous situation for the contamination of sewage pipes into other pipes around the structure.

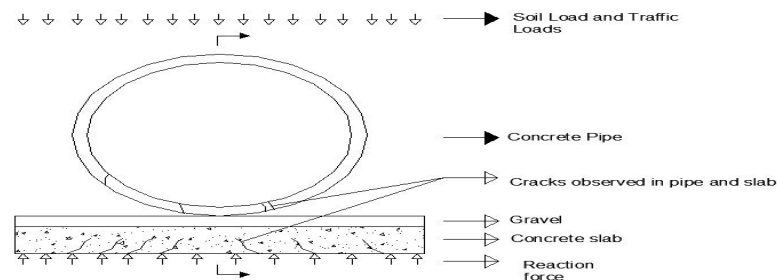

Figure 23: Cracking in a slab.

It is very necessary to find the reason for the formation of the cracks and remove the problem to prevent the further increase of the cracking. The proper use of reinforcement and choosing the right cement according to the soil condition will help prevent the cracking of soil. If the soil is acidic and has different chemicals, then the soil is removed and treated. Various admixtures are added during the construction time according to the nature of the soil. In order to prevent the water entering inside the slab and rusting the rebar's, it is important to main the minimum concrete cover on a slab. The rusting of rebars will also lead to the cracking of the slab.

If the design of the slab is for a long time and if it gets broken down after a few years of use, then the engineering failure will lead to loss of tax payer's money as well as to the reputation of the construction company and of the consultant. Therefore, choosing the right admixture, rebar size and making the stable ground conditions will determine the life of the slab.

The general considerations that have to be taken into account for the crack control according to the EN 1992-1-1 are the following:

Minimum cracking should be taken into account until and unless it doesn't hamper the proper functioning or the strength of the structure or cause its form to be unacceptable. Similarly, the limiting calculated crack width  $W_{max}$  should be taken into account. The value of  $W_{max}$  can be found in the national Annex of each individual country while the recommended value of EuroCode is also present depending upon the relevant exposure class.

The recommended value of  $W_{max}$  can be found in Table 7.1 in EuroCode 1992-1-1. (European Standard Institution, 2004, p. 126)

The crack width,  $W_K$  can be calculated from below expression:

$$W_K = S_{r,max} (\epsilon_{sm} - \epsilon_{cm})$$

Where,

$S_{r,max}$  = maximum crack spacing

$$S_{r,max} = k_3 c + k_1 k_2 k_4 \frac{\phi}{\rho_{p,eff}}$$

$\epsilon_{sm}$  = mean strain in the reinforcement

$\epsilon_{cm}$  = mean strain in the concrete between cracks.

$$\epsilon_{sm} - \epsilon_{cm} = \frac{\sigma_s - k_t \frac{f_{ct,eff}}{\rho_{p,eff}} (1 + \alpha_e * \rho_{p,eff})}{E_s} \geq 0.6 \frac{\sigma_s}{E_s}$$

$\sigma_s$  = stress in the tension reinforcement assuming a cracked section.

$k_t$  = factor dependent on the duration of the load.  $k_t = 0.6$  and  $0.4$  for short and long term loading respectively.

$f_{ct,eff}$  = is the mean value of the tensile strength of a concrete.  $f_{ct,eff} = f_{ctm}$

$$\rho_{p,eff} = \frac{(A_s)}{A_{c,eff}}$$

$A_s$  = cross sectional area of reinforcement

$A_{c,eff}$  = effective area of concrete in tension surrounding the reinforcement,  $h_{c,eff}$ . Where

$h_{c,eff}$  is lesser of  $\min(2.5(h-d), (h-x)/3, h/2)$

$\alpha_e$  = ratio of  $E_s / E_{cm}$

$E_s$  = design value of modulus of elasticity of reinforcing steel

$E_{cm}$  = decant modulus of elasticity of concrete

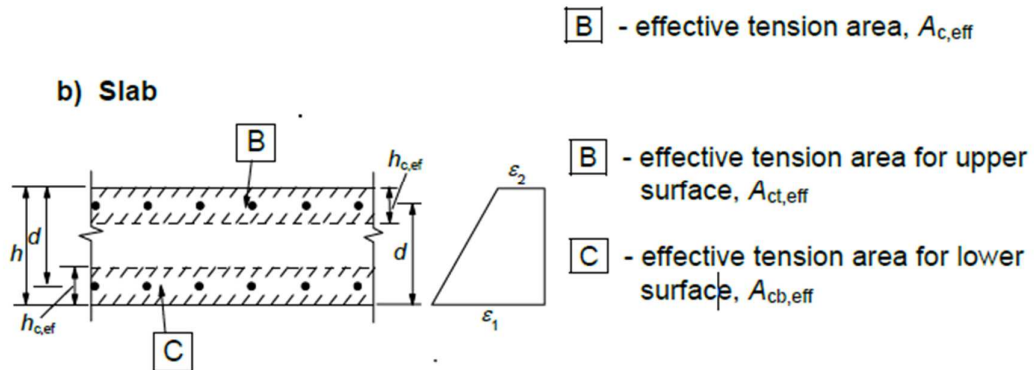

Figure 24: Slab in Tension. (European Standard Institution, 2004, p. 124)

The final crack width was calculated to be 0.91mm which can be studied from Appendix 2.

$$W_k = 1087.5\text{mm} * 0.000841 = 0.74 \text{ mm}$$

## 6 Finite Element Method (FEM)

FEM or finite element method is by far the most powerful method to solve the complex numerical problem. The FEM solving technique helps us to find the approximate solutions to boundary value problems for partial differential equations. FEM is also commonly known as Finite element analysis (FEA). The major idea of FEM software is that it divides the whole problems into the smaller parts called finite elements and solves the equations of those finite elements and assembles them which gives us the full result of the problem. FEM is widely used in civil, aeronautical, mechanical, mining and lots of other sectors. In this problem Autodesk Robot Structural Analysis Professional 2014 (FEM) was used to calculate the moment and other necessary values in a slab. As there are lots of loads coming to the slab from the top in a form of dead loads and live loads, supports system of columns were made from deep soil mixing method.

With the average value of  $k_s$  known which is  $1523.2 \text{ kN/m}^3$ , it was possible to calculate the moment, deflection and soil-slab interaction pressure in a slab with and without support. The total number of initial support system was 19 and the radius of the column was 300mm which was reduced after design optimization to 14 columns with 400mm radius and c/c distance of 1700mm.

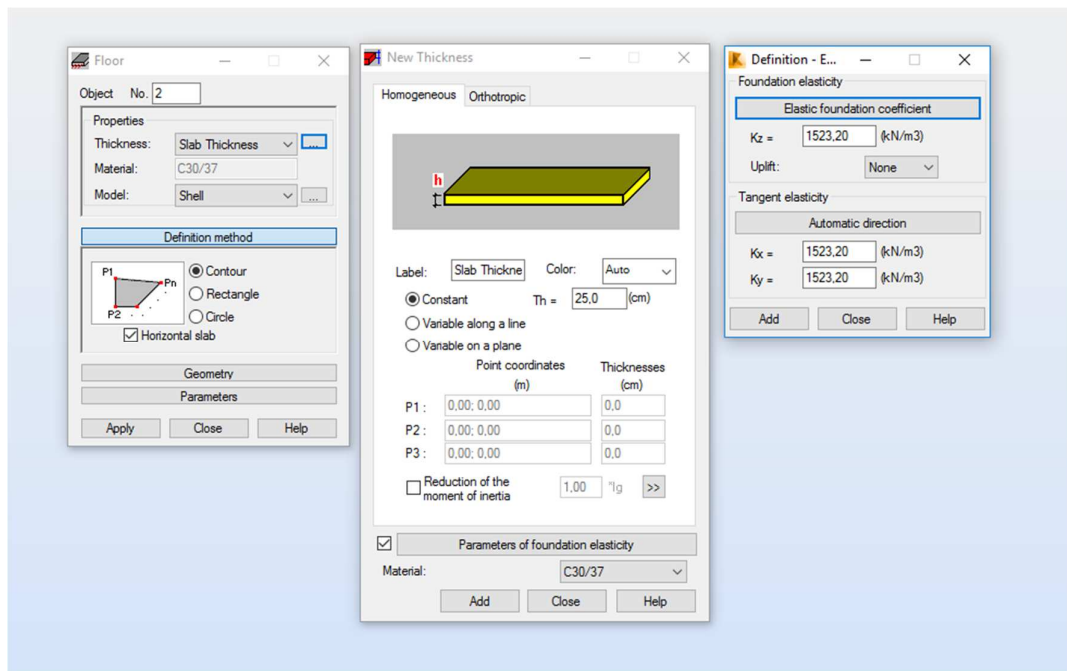

Figure 25: Settings in Robot Structural Analysis (FEM)

In Figure 25 the common settings can be seen that were used in Robot Structural Analysis to calculate the required values of moments, displacement, soil-slab interaction values and reaction forces. At first, the analysis was conducted with the use of soil as an only support system and the result can be seen in Figure 26.

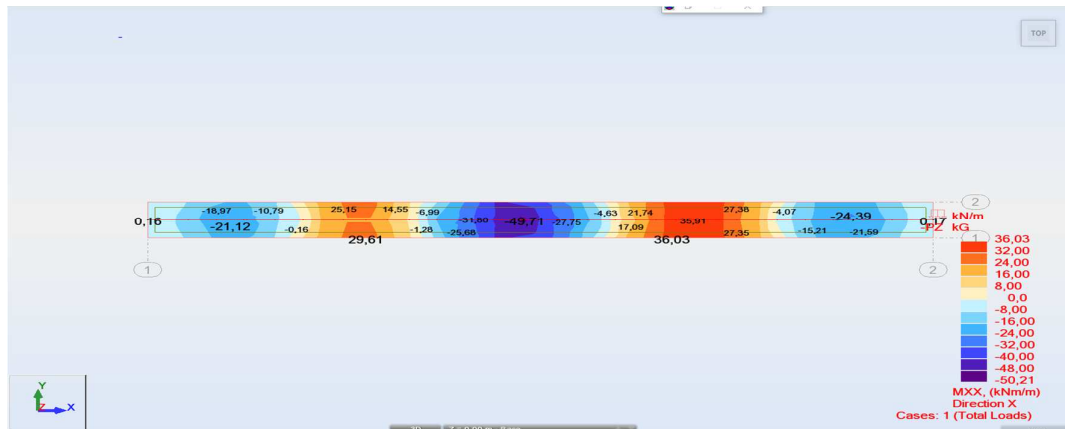

Figure 26: Moment values in the X direction with only soil as a support system.

The various load values obtained from the calculation were applied in the middle of the slab. The maximum value of moment was calculated with soil as an only support system and the obtained value is 50.21kNm. At first, when soil was only used a support system the deflection was very high. The maximum displacement noted in the calculation was 4.1 cm which can be seen from Figure 27. The maximum displacement noted was in the middle of the slab. In the corner areas, the noted displacement was 3.4 to 3.5 cm.

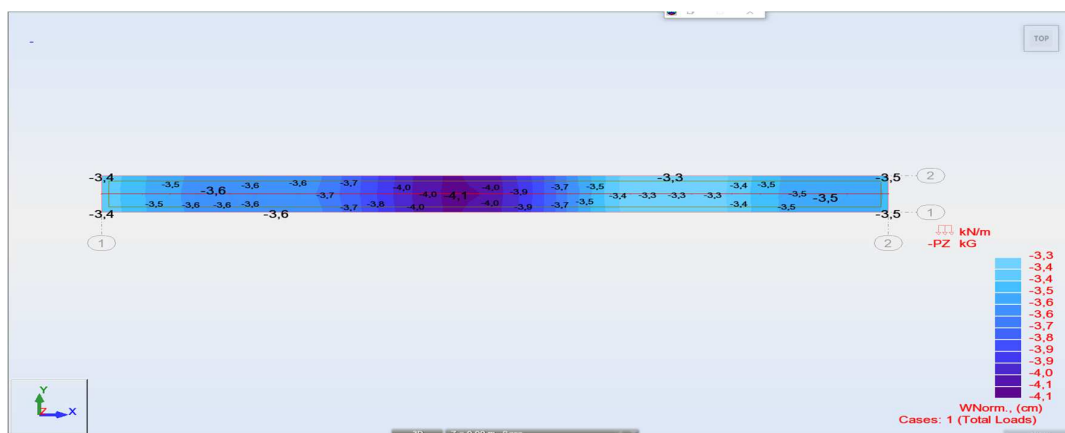

Figure 27: Displacement in the slab with only clay support in cm.

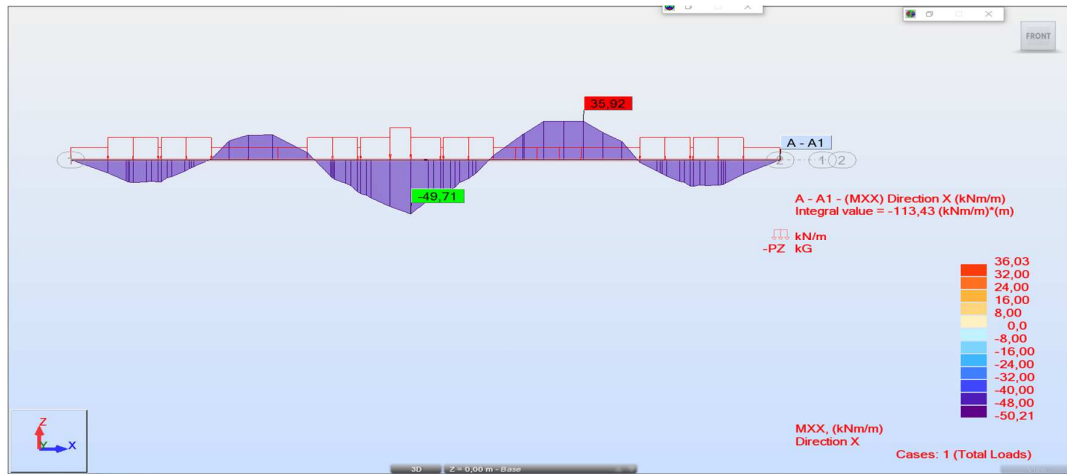

Figure 28: Moment value in A-A1 section (0,0.75) ; (24,0.75) cut in 2 points.

From the calculation of  $k_s$ , it can be seen that the value of  $k_s$  doesn't depend on the bearing capacity of soil but it rather depends on the settlement and the load, that is being applied to it. Similarly, from the calculation, it can be seen that there are lots of tension points in slab which means there is a deflection in a slab.

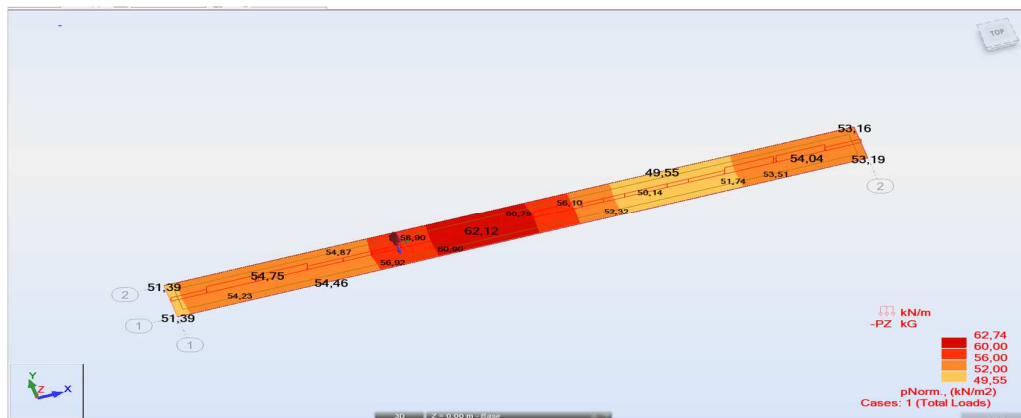

Figure 29: Soil reaction values.

As there was plenty of deflection in slab it is necessary to provide support for a slab. Columns which were made by the deep soil mixing method was used to provide support for a slab. The maximum deflection noted was in the centre where the combined loading is present. From Figure 29 soil-slab reaction value can be calculated and the maximum value is 62.74kN/m<sup>2</sup>. Secondly, the support system that was made from DSM method



were placed and the analysis was done. From the analysis, we have the following result as seen in Figure 30.

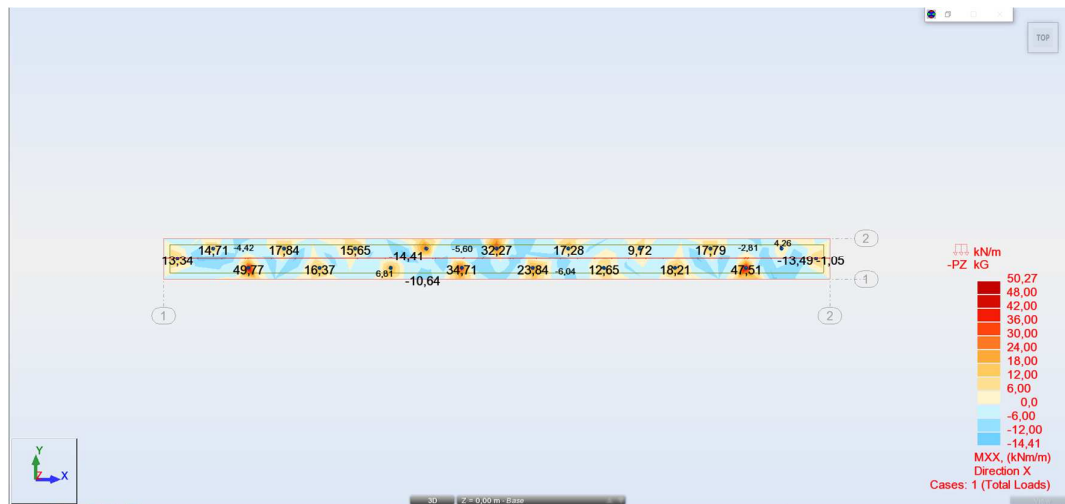

Figure 30: Moment values in the X direction with DSM columns supports system.

In Figure 26 and Figure 30 completely different result is obtained. When the soil was only used as a support system for the slab, the slab was in tension in various areas as well as slab had a plenty of deflection. But figure 30 shows a different result. In figure 30 it can be seen that slab is completely normal and there is only minor tension near the support system. The maximum value of moment noted was near the support system which is 50.27kNm. With supports of 19 columns, deflection was none. It was zero. The most important value is to determine the distance between the columns.

When the analysis was performed with 19 columns it was noted that the maximum reaction force in the columns was 158.57kN. From the calculation, it was noted that the maximum load that the column of radius 300mm of compressive strength 400kPa can withstand is 113.09 kN. Since from analysis, it can be seen that reaction force is maximum than what the columns can carry which would cause it to fail. Therefore, there has to be a change in the details of the column. It was decided to increase the radius of the column to 400mm from 300mm which would give the sufficient strength to support the slab on the top as seen from the calculation.

In Figure 31 sectional values of the moment in X – direction for initial support system with 19 columns is shown. There is not a significant tension in the slab except near the support system which means more rebar is needed near the support system.

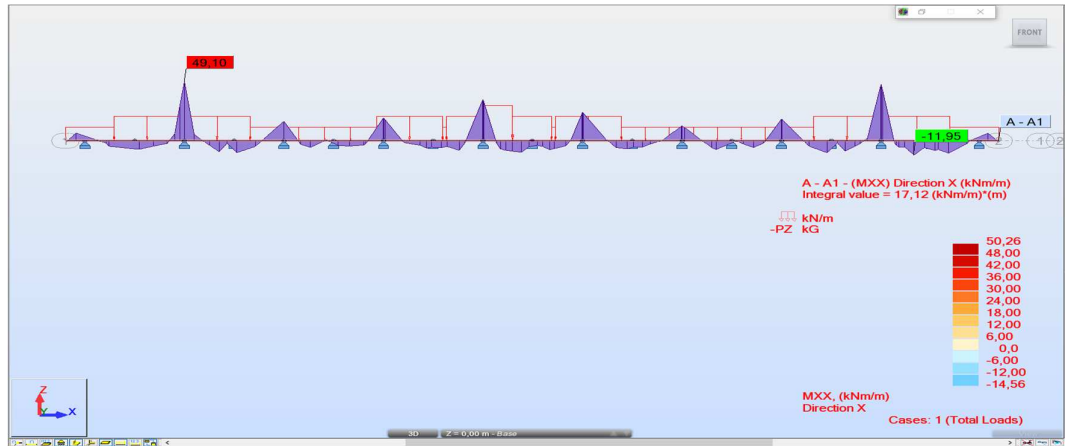

Figure 31: A-A1 section( 0,0.41), (24,0.41) moment values.

### 6.1 Design Optimization

From the calculations, the maximum reaction force for supports, moments and deflection in the slab was noted. Initially, support columns of a radius 300mm having a compressive strength of 400kPa was designed. Initial idea was to use the column of less radius to save concrete but from the calculation, it can see that making a smaller radius will not be able to hold all the force that will come to the slab.

Node/Case	FZ (kN)
133/ 1	70,01
125/ 1	70,79
138/ 1	79,13
120/ 1	83,51
124/ 1	84,35
131/ 1	84,39
132/ 1	84,80
124/ 1	86,39
134/ 1	86,71
137/ 1	88,77
135/ 1	97,57
123/ 1	99,85
126/ 1	111,21
127/ 1	121,23
130/ 1	124,54
129/ 1	136,97
128/ 1	150,45
136/ 1	158,26
122/ 1	158,57

Figure 32: Support reaction values for 19 columns according to the first planned arrangement as seen in Figure 9.

So, by using the compressive strength of 400kPa of 300mm radius column,

$$\text{Load that one 300mm radius column can withstand} = \pi * 0.3^2 * 400\text{kPa} = 113.09\text{kN}$$

$$\text{Total load that 19 columns can withstand} = 2148.71\text{kN}$$

$$\text{Total load that is coming from the top to the slab} = 1984\text{kN}$$

But from analysis, it can see that there is more reaction force than what one column can withstand as shown in Figure 32. The maximum reaction force was obtained which is 158,57kN. The design of column has to be done according to the obtained force.

So, it was decided to change the radius of 300mm column to 400mm radius. After changing the radius of columns from 300mm to 400mm the capacity of the columns was that it can withstand a load of 201.06kN.

$$\text{Load that one column of radius 400mm can withstand} = \pi * 0.4^2 * 400\text{kPa} = 201.06\text{kN}$$

$$\text{Total load that 19 columns can withstand} = 3820.14\text{kN}$$

Since there was more excessive support force, it was decided to change the number of columns to 14 from 19. From the calculation total support force was calculated which is 2814.84kN. This force is sufficient to support the slab.

$$\text{Total load that 14 columns can withstand} = 2814.84\text{kN}$$

From the calculation and from Figure 35 (b) it can see that the radius of 400mm will be a solution of the problem. The columns will be of compressive strength 400kPa and c/c distance of 1700mm. The final design is done according to this result.

In order to confirm the calculation and to make a proper decision on the arrangements of columns. Two different types of arrangements were analysed without a change in any properties of the column. Only the arrangement of the columns was changed as shown in Figure 33.

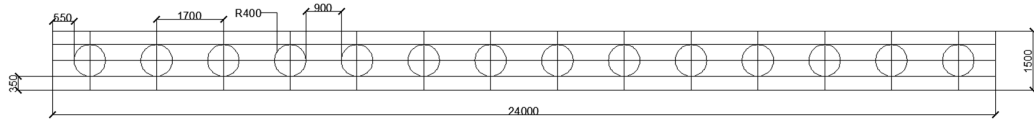

(a)

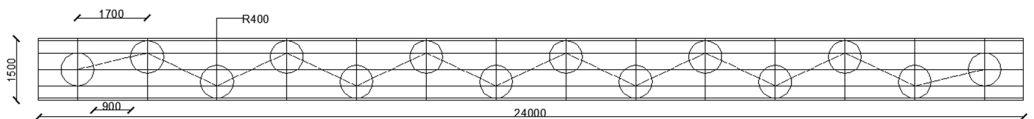

(b)

Figure 33: (a), (b) shows the middle and triangular plan arrangement for DSM columns respectively.

In Figure 33 (a) columns were placed in the middle of the slab while in (b) the columns were kept in a triangular arrangement. With only the change in the arrangement of columns, two different values of reactions in the slab was obtained. While columns were in the middle of the slab, the maximum value of moment was 44.78 kNm as seen in Figure 34 (a).



(a)

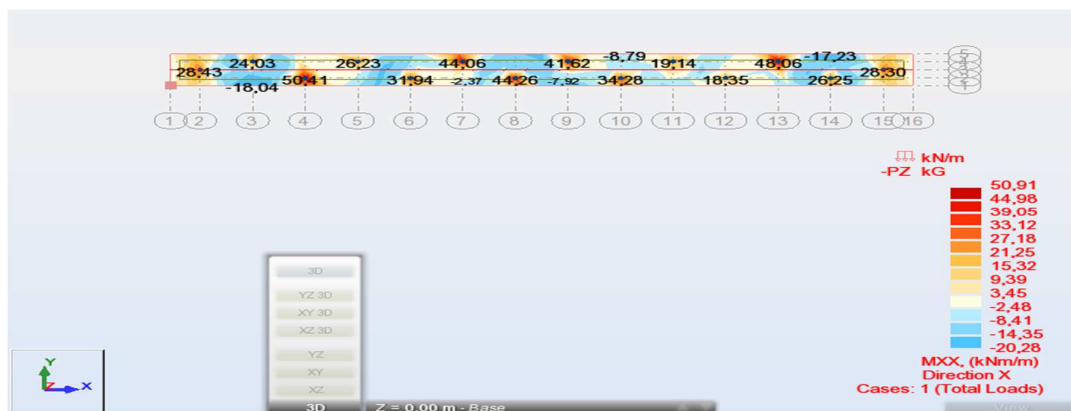

(b)

Figure 34: Moment values for two different columns arrangements.(a) columns are in the middle of the slab. (b) columns are in the triangular arrangement.

From the triangular arrangement, the maximum value of the moment obtained was 50.91 kNm. Similarly, the reaction force in the support system was also different as seen in Figure 35.

Node/Case	FZ (kN)
41/ 1	91,70
42/ 1	105,57
36/ 1	119,82
40/ 1	123,83
31/ 1	139,44
45/ 1	139,55
34/ 1	141,12
35/ 1	143,25
44/ 1	150,79
32/ 1	151,62
33/ 1	153,67
43/ 1	158,47
39/ 1	170,11
37/ 1	200,51

(a)

Node/Case	FZ (kN)
201/ 1	90,56
200/ 1	101,79
199/ 1	122,65
194/ 1	127,64
192/ 1	129,96
203/ 1	134,19
195/ 1	136,80
196/ 1	138,24
204/ 1	145,48
190/ 1	146,75
198/ 1	173,51
202/ 1	175,82
193/ 1	178,82
197/ 1	184,00

(b)

Figure 35: Value of reaction force for columns. (a) reaction force for middle arrangement, (b) triangular arrangement of columns.

In Figure 35 (a) and (b) two different column supports reaction values can be seen for the two different arrangement. The Figure 35 (a) values were obtained when the columns were placed in the middle of the slab, while Figure 35 (b) value is for the arrangement of columns when they were placed in the triangular arrangement. From the above figure, it can be seen that the triangular arrangement is better than the middle one.

After all the calculations final design was done with a triangular arrangement of columns. Columns have a compressive strength of 400kPa and radius of 400mm. Columns are kept at a centre to centre distance of 1700mm. The total number of columns used in the design process was 14 which would obtain the sufficient carrying capacity for the slab.

## 7 Final Design

The final design was done according to the triangular arrangement of columns. The plan can be seen in Figure 38. The maximum calculated value of the moment is 50.91kNm, but 51kNm was used as a value of moment during the calculation. The full calculation can be studied from the Appendix 2. The slab was designed according to those calculations.

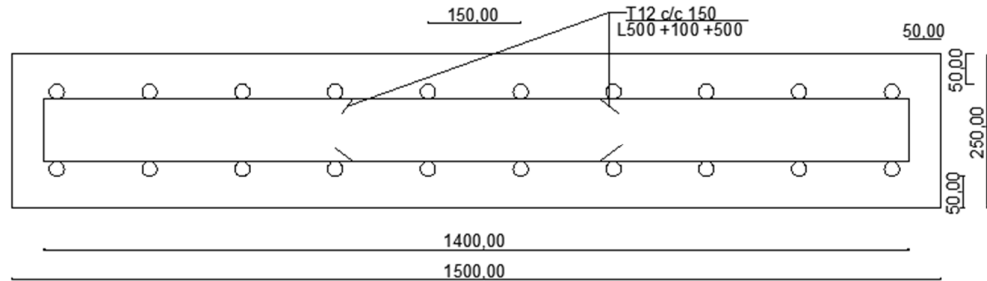

(a)

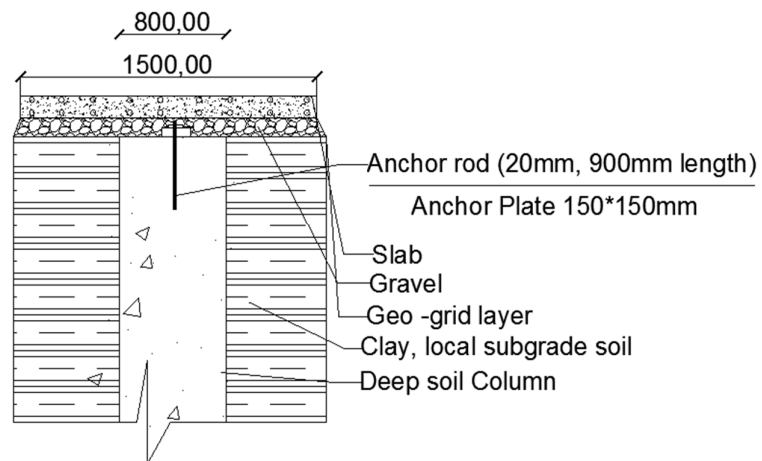

(b)

Figure 36: (a) sectional drawing of slab. (b) sectional drawing of DSM column.

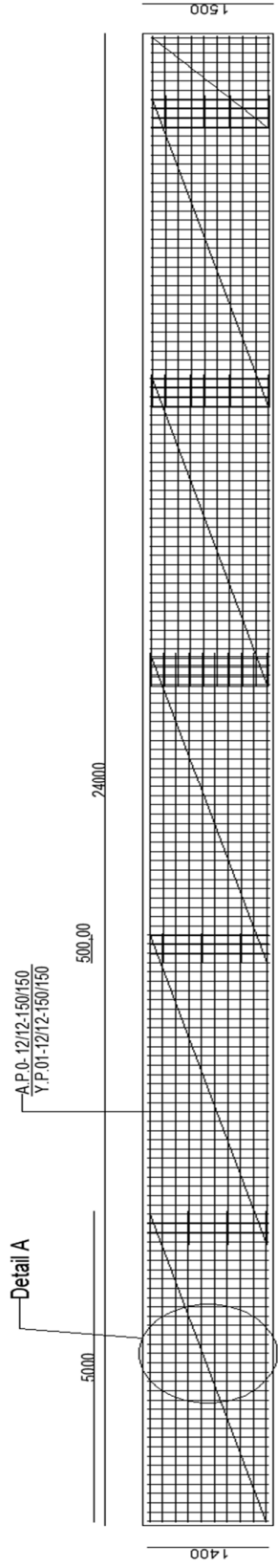

(a)

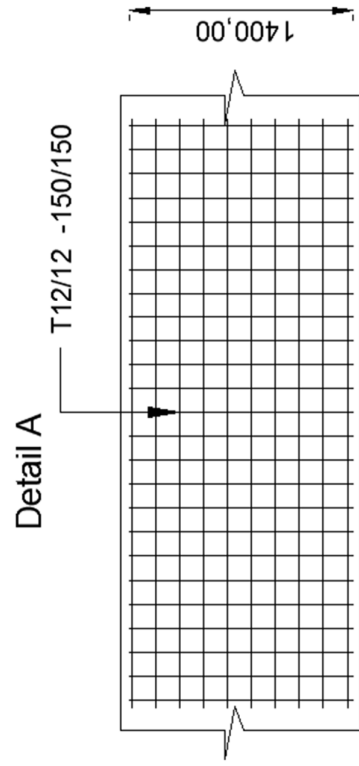

(b)

Figure 37: (a) Plan view of slab, (b) detail view of slab.



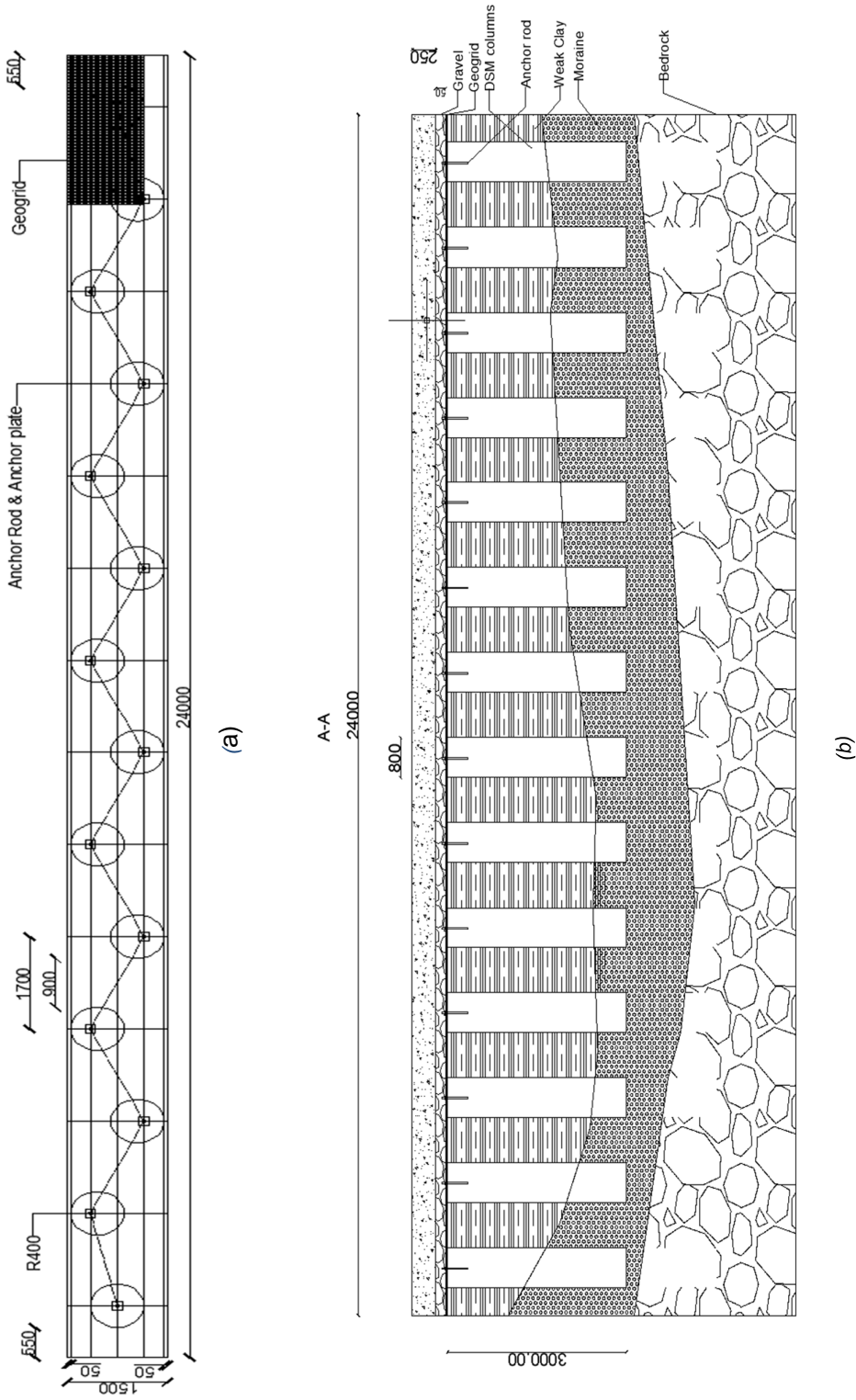

Figure 38: (a) shows the plan view , (b) is the A-A sectional view.

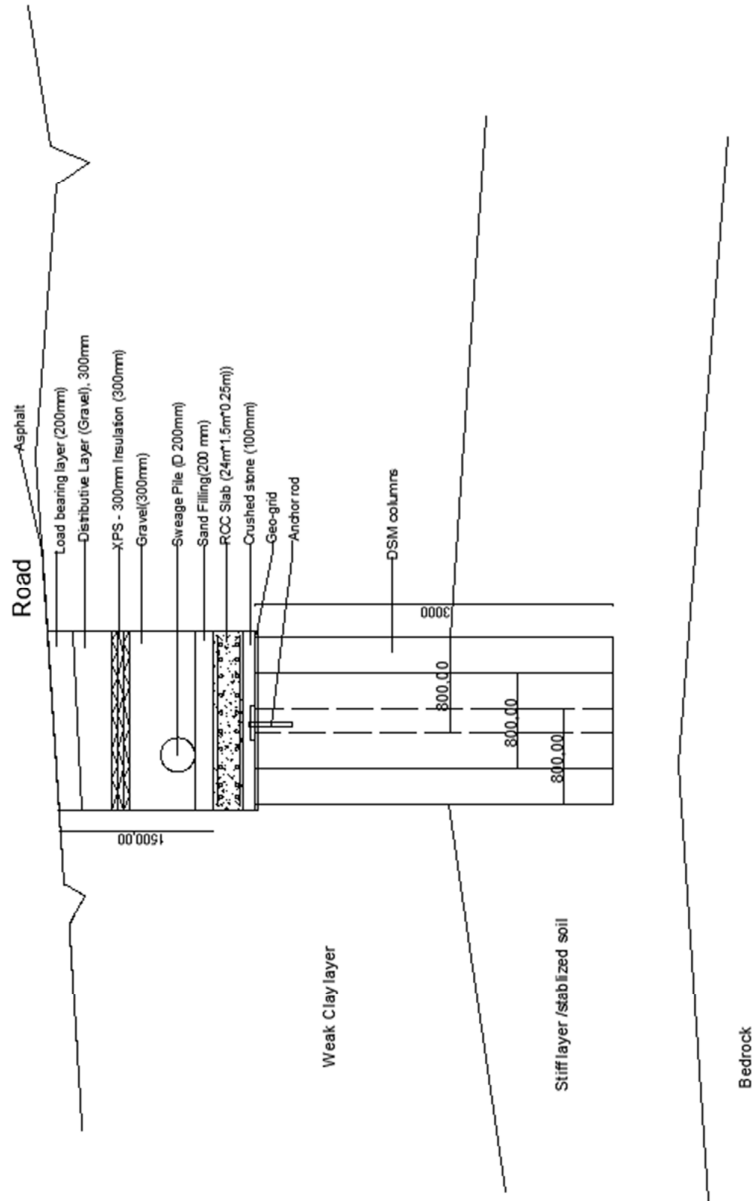

Figure 39: Road section with slab and DSM columns as a support system.

## 8 Conclusion

Engineering is a challenging working environment as we have to make new ideas in every project, engineering is about facts. Every project is a new project. We solve the complex problems mathematically and try to find the best answer. For engineering students like me solving the puzzle of designing a slab in a weak soil was an excellent opportunity to learn new things and begin my career in designing of the structures. In school usually, the design of basic structures with basic problems are studied. Being able to conduct a research and solve the real problems helped me learn many new things and I think it will be very useful for me in upcoming years.

The main objective was to find a suitable solution for the design of the slab which was fulfilled with the design of the column of 400mm radius with a compressive strength of 400kPa. Firstly the maximum deflection in a slab was calculated keeping clay as a support system. On the process, the modulus of subgrade reaction was calculated using the Bowels formula as shown in Appendix 2.

After the calculation of modulus of subgrade reaction for a flexible foundation, data were input to the Robot Structural Analysis (FEM) and the value of deflection and moment were calculated. The deflection was very high due to the settlement of the slab. Since it is not possible to construct the slab with a high amount of deflection, the cheap and effective solution for the problem was to provide the support system which was created by deep column mixing. It is beneficial to increase the length of insulation used, at least 100mm in each side to preserve the moisture in the final design.

The compressive strength of the column is very hard to predict but from various notable writers, it was concluded that the compressive strength of columns depends on clay and water-concrete ratio. A column of compressive strength 400kPa was used as the support system for the slab. After the calculation of spacing and the diameter of the column, the length of the column was decided to be of 3 m assuming that there is a better soil with a higher bearing capacity of soil as the depth increases. If there isn't a better soil below the layer of clay in a shorter distance, it is possible to increase the length of a column with an increase in diameter and compressive strength of column or to use a different method as a support system.

Finally, the analysis with DSM support system was done. From the above calculation, it can be seen that that use of support system decreases the tension in the slab as seen in Figure 30. The number of columns can be reduced but the deflection and the reaction force have to be noted.

## 9 References

1. Binod Tiwari, S. M. L., 2008. Measurement of Shear Strength of Soil. [Online] URL: [http://faculty.fullerton.edu/btiwari/geotech\\_Lab/mainpage\\_files/other/Unconfined%20Compression%20Test.pdf](http://faculty.fullerton.edu/btiwari/geotech_Lab/mainpage_files/other/Unconfined%20Compression%20Test.pdf) Accessed 16 05 2016.
2. Builder's Engineer, n.d. The design of foundations. [Online] URL: <http://www.abuildersengineer.com/2012/10/design-of-foundations-presumptive.html> Accessed 15 03 2016.
3. Chandra, S., 2014. Modelling of Soil Behaviour, Kanpur: Indian Institute of Technology.
4. Civil Engineering Home, n.d. Soil Improvement. [Online] URL: <http://theconstructor.org/geotechnical/soil-improvement/1410/> Accessed 18 03 2016.
5. Concrete Network, n.d. What is subbase soil?. [Online] URL: <http://www.concretenetwork.com/concrete-subgrades-subbases/what-is.html> Accessed 21 04 2016.
6. Concrete reinforcing steel institute, n.d. Reinforcing steel. [Online] URL: <http://www.crsi.org/index.cfm/steel/about> Accessed 25 04 2016.
7. Curl, J. S., 2000. reinforced concrete. [Online] URL: [http://www.encyclopedia.com/topic/reinforced\\_concrete.aspx](http://www.encyclopedia.com/topic/reinforced_concrete.aspx) Accessed 01 04 2016.
8. European Standard Institution, 2004. Eurocode 2 : Design of concrete structures. Part 1-1 : Generals rules and rules for buildings, s.l.: European Standard Institution.

9. Bell, F.G, 1996. Lime Stabilization of clay minerals and soil, South Africa: Department of Geology and Applied Geology, University of Natal .
10. Hayward Baker, n.d. Vibro Replacement. [Online]  
URL: <http://www.haywardbaker.com/WhatWeDo/Techniques/GroundImprovement/VibroReplacement/default.aspx> Accessed 10 5 2016.
11. IIT Kanpur, India, n.d. Foundation and analysis and design. [Online]  
URL: <http://home.iitk.ac.in/~aprashan/ce632/PPT/CE%20632%20Settlement2009%20Handout.pdf> Accessed 20 05 2016.
12. Nenonen, Jari and Portaankorva Anne, 2009. The geology of the Lakeland Finland, s.l. Geological Survey of Finland.
13. Kennet, Y. B., n.d. Stabilization of soft soil by soil mixing, s.l.: s.n.
14. Korkiala, L., 2012. Recent developments in Finnish deep mixing technologies. [Online] Available at  
[https://www.google.com/url?sa=t&rct=j&q=&esrc=s&source=web&cd=3&cad=rja&uact=8&sqj=2&ved=0ahUKEwjPz\\_Pag\\_PMAhXIBywKHT-kxD6EQFgg1MAI&url=http%3A%2F%2Fwww.sgf.net%2Fget-file.ashx%3Fcid%3D484178%26cc%3D3%26refid%3D5&usg=AFQjCNHmei-KoCgPQu3f7RV3EtixsNVK9Tg&sig2=T](https://www.google.com/url?sa=t&rct=j&q=&esrc=s&source=web&cd=3&cad=rja&uact=8&sqj=2&ved=0ahUKEwjPz_Pag_PMAhXIBywKHT-kxD6EQFgg1MAI&url=http%3A%2F%2Fwww.sgf.net%2Fget-file.ashx%3Fcid%3D484178%26cc%3D3%26refid%3D5&usg=AFQjCNHmei-KoCgPQu3f7RV3EtixsNVK9Tg&sig2=T)  
Accessed 23 05 2016.
15. M.Das, B., n.d. Elastic settlement of shallow foundations on granular soil. [Online] URL: [http://gle.wisc.edu/wp-content/uploads/2013/07/Elastic-Settlement-Shallow-Foundations\\_A-Critical-Review-2.pdf](http://gle.wisc.edu/wp-content/uploads/2013/07/Elastic-Settlement-Shallow-Foundations_A-Critical-Review-2.pdf) Accessed 15 05 2016.
16. Lewis, M.R, Static Modulus of subgrade reaction. Static Modulus of subgrade reaction,
17. Masaki kitazume, M. t., 2012. The deep mising method. 1st ed. Tokyo: CRS press.

18. Morgan, W., 2015. Reinforced Concrete. [Online] URL: [http://www.jfccivilengineer.com/reinforced\\_concrete.htm](http://www.jfccivilengineer.com/reinforced_concrete.htm) Accessed 01 03 2016.
19. National ready Mixed Construction Association, n.d. CIP #19 - Curling of Concrete Slabs. [Online] URL: [http://www.nrmca.org/converted\\_pdfs/cip\\_19.asp](http://www.nrmca.org/converted_pdfs/cip_19.asp) Accessed 12 04 2016.
20. Pbs.org, n.d. Interview with Stacey Loizeaux. [Online] URL: <http://www.pbs.org/wgbh/nova/kaboom/loizeaux.html> Accessed 22 05 2016.
21. Pile Foundations, n.d. Pile Foundations. [Online] URL: <http://www.understandconstruction.com/pile-foundations.html> Accessed 30 4 2016.
22. Plate bearing test, n.d. Plate bearing test. [Online] URL: [http://www.southerntesting.co.uk/assets/images/stl\\_pdf/Technical\\_In-situ%20Testing%20CBR%20Plate%20Bearing.pdf](http://www.southerntesting.co.uk/assets/images/stl_pdf/Technical_In-situ%20Testing%20CBR%20Plate%20Bearing.pdf) [Accessed 20 05 2016].
23. Powrie, W., 1997. Soil Mechanics Concepts & Applications. 2nd ed. New York : Taylor and Francis .
24. Proebe, H. J., n.d. Design of Vibro replacement, s.l.: s.n.
25. Puppala, A. J., 2008. Design of deep soil mixign columns for mitigation of heave, Arlington: The University of Texas.
26. Quality Lime and Stone Products, n.d. Benefits of Lime Treatment. [Online] URL: [http://www.graymont.com/sites/default/files/brochures/pdf/03\\_soil\\_stabilization-\\_lime\\_treated\\_soil\\_save\\_time\\_money\\_.pdf](http://www.graymont.com/sites/default/files/brochures/pdf/03_soil_stabilization-_lime_treated_soil_save_time_money_.pdf) Accessed 22 4 2016.
27. Gilbert, R.I, .. Detailin of reinforcement in concrete structures. [Online] URL: [https://www.engineersaustralia.org.au/sites/default/files/detailing\\_of\\_reinforcement\\_in\\_concrete\\_structures\\_28\\_aug\\_2012.pdf](https://www.engineersaustralia.org.au/sites/default/files/detailing_of_reinforcement_in_concrete_structures_28_aug_2012.pdf) Accessed 12 03 2016.
28. Rao, N., 2011. Foundation Theory. 1st ed. s.l.:Wiley.com.

29. Renwick, P., 2008. Stresses Induced by Wheels Below the Surface of a Soil Roa. [Online] URL: <http://www.jmu.edu/cisr/journal/12.1/rd/renwick/renwick.shtml> Accessed 18 05 2016.
30. Soil Properties, n.d. Classification of soil. [Online] URL: <http://osp.mans.edu.eg/geotechnical/Ch1C.htm> Accessed 18 5 2016.
31. Spectra Roadway improvement system, n.d. Roadway section optimization. [Online] URL: <http://www.roadsbridges.com/sites/rb/files/Tensar%20Spectra%20Brochure.pdf> Accessed 20 05 2016.
32. Straughan, W. T., 1990. Analysis of plates in elastic foundations, s.l.: Willia.
33. The California Producers Committee an Volume Change and Affiliated Technical Organizations, 1966. Drying Shrinkage of Concrete, Oakland California: California Producers Committee.
34. Tribedi, A., 2013. Correlation between soil bearing capacity and modulus of subgrade reaction. [Online] URL: <http://www.structuremag.org/?p=1239> Accessed 01 03 2016.
35. Celep, Z. F., 2007. Symmetrically loaded beam on a two parameter tensionless foundation, Istanbul: Istanbul Technical University, Department of Structural and Earthquake Engineering.

S.No.	Type of rocks and soils	Presumptive safe bearing capacity		
		Kg/cm <sup>2</sup>	t/m <sup>2</sup>	kN/m <sup>2</sup>
	<i>(a) Rocks</i>			
1.	Rocks (hard) without laminations and defects, for example, granite, trap and diorite.	33	330	3300
2.	Laminated rocks, for example, sand stone and lime stone in sound conditions.	16.5	165	1650
3.	Residual deposits of shattered and broken bed rock and hard shale, cemented material .	9.0	90	900
4.	Soft rock.	4.5	45	450
	<i>(b) Non-cohesive soils</i>			
5.	Gravel, sand and gravel, compact and offering high resistance to penetration when excavated by tools (Note 1).	4.5	45	450
6.	Coarse sand, compact and dry (with ground water level at a depth greater than width of foundation, below the base of footing).	4.5	45	450
7.	Medium sand, compact and dry.	2.5	25	250
8.	Fine sand, silt ( dry lumps easily pulverised by fingers).	1.5	15	150
9.	Loose gravel or sand gravel mixture ; loose coarse to medium sand, dry (Note 1).	2.5	25	250
10.	Fine sand, loose and dry	1.0	10	100
	<i>(c) Cohesive soils</i>			
11.	Soft shale, hard or stiff clay in deep bed, dry (This ground is susceptible to long term consolidation settlement).	4.5	45	450
12.	Medium clay, readily indented with a thumb nail.	2.5	25	250
13.	Moist clay and sand clay mixture which can be indented with strong thumb pressure.	1.5	15	150
14.	Soft clay indented with moderate thumb pressure.	1.0	10	100
15.	Very soft clay which can be penetrated several centimetres with the thumb.	0.5	5	50

Figure 40: Presumptive bearing capacity of various soil types. (Builder's Engineer)



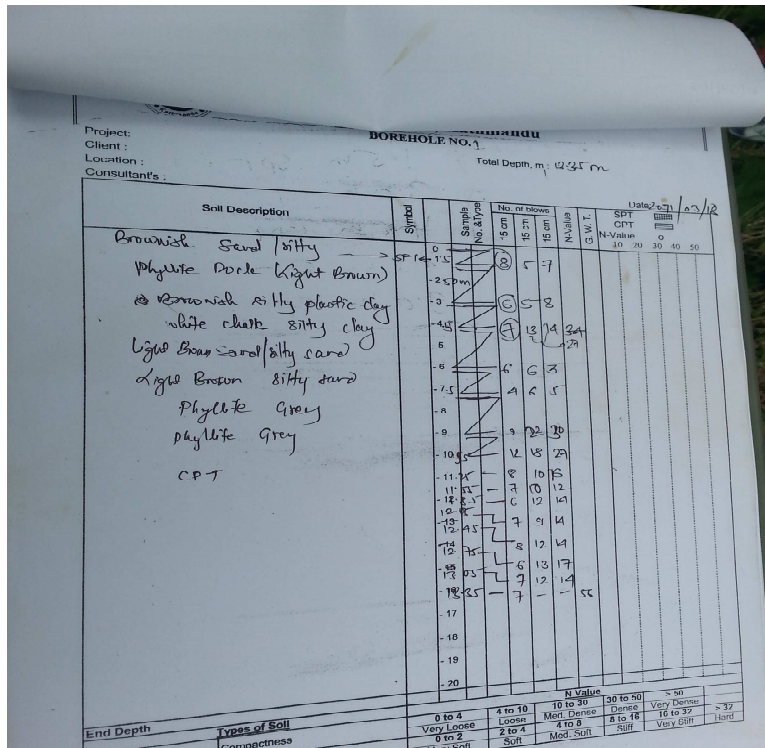

Figure 41: Sub soil exploration sample document from water reservoir project

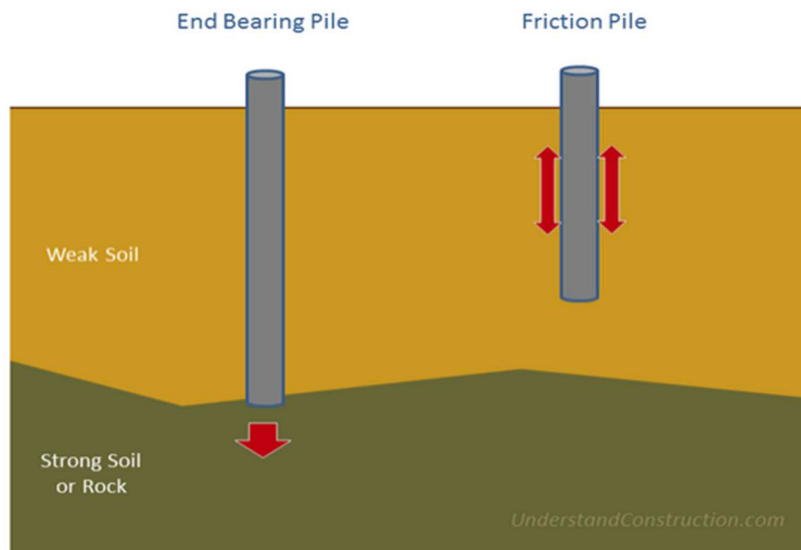

Figure 42: End bearing pile and Friction pile. (Pile Foundations)

Figure 43: Plate bearing test setup. (*Plate bearing test*)

Categories of traffic areas	$q_k$ [kN/m <sup>2</sup> ]	$Q_k$ [kN]
<b>Category F</b> Gross vehicle weight: $\leq 30$ kN	$q_k$	$Q_k$
<b>Category G</b> $30 \text{ kN} < \text{gross vehicle weight} \leq 160$ kN	5,0	$Q_k$

NOTE 1 For category F,  $q_k$  may be selected within the range 1,5 to 2,5 kN/m<sup>2</sup> and  $Q_k$  may be selected within the range 10 to 20 kN.

NOTE 2 For category G,  $Q_k$  may be selected within the range 40 to 90 kN.

NOTE 3 Where a range of values are given in Notes 1 & 2, the value may be set by the National annex.  
The recommended values are underlined.

Figure 44: Traffic loading values from EuroCode EN 1991-1-1:2002(E).

## Calculations

We have a slab of  $24\text{m} \times 1.5\text{m} \times 0.25\text{m}$  which is located at a depth of  $1.5\text{m}$  from surface. The thickness of a slab is taken to be  $0.25\text{m}$ . For a small slab of length  $6\text{m}$ , we can see a traffic load distribution in Figure 21. In this case we have a slab of  $24\text{m}$  and the total calculated load distribution is as shown in Figure 19. We are going to breakdown the calculations and solve the problem. We have to examine the shrinkage and width of crack in the slab. In order to calculate the moment, the Robot Structural Analysis (FEM) software was used as we have various loading condition which is very hard and complex to calculate manually.

Modulus of Subgrade reaction ( $k_s$ )

Subgrade reaction ( $k_s$ ) can be determined by using given expression:

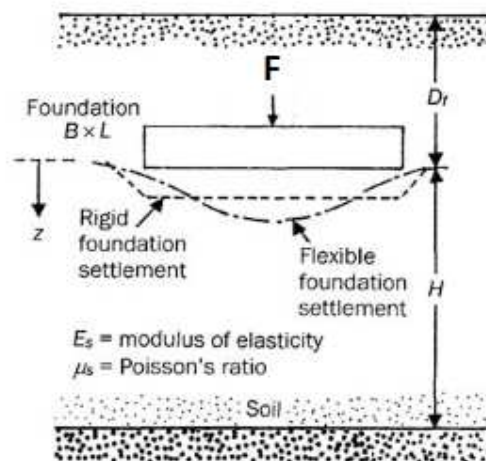

Figure 45: Rigid and flexible foundation. (M.Das)

$$k_s = \frac{1}{B} \left[ 0.65 * \sqrt[12]{\frac{E_s B^4}{I_f E_f}} \right] * \frac{E_s}{1 - \mu_s^2}$$

$E_s, E_f$ = Modulus of soil and footing, respectively, in consistent units

$B, I_f$ = Footing width and its moment of inertia based on cross section (not plan)  
in consistent units

Since the twelfth root of any value times 0.65 will be close to 1, for all practical purposes the Vesic (1961) equation reduces to:

$$k_s = \frac{E_s}{B * (1 - \mu_s^2)}$$

According to the Bowels formula,

$$\Delta H = q_0 B' \frac{1 - \mu^2}{E_s} * m I_s I_f$$

Where;

$\Delta H$  = settlement

$M$  = number of corners contributing to settlement

For footing center  $m = 4$  and at the side  $m = 2$  and at the corner  $m = 1$

According to Bowels Formula;

$$E'_s = \frac{1 - \mu^2}{E_s}$$

For  $k_s$  calculation we use ;

$$\Delta H = \Delta q B' E'_s m I_s I_f$$

$$k_s = \frac{\Delta q}{\Delta H} = \frac{1}{B' E'_s m I_s I_f}$$

From Steinbrenner (1934), shape factor( $I_s$ ) can be obtained by:

$$I_s = F_1 + \frac{1 - 2\mu_s}{1 - \mu_s} * F_2$$

$$F_1 = \frac{1}{\pi} (A_0 + A_1)$$

$$F_2 = \frac{n}{2\pi} \tan^{-1}(A_2)$$

Where,

$$A_0 = m * \ln \left[ \frac{(1 + \sqrt{1 + m^2})\sqrt{m^2 + n^2}}{m(1 + \sqrt{m^2 + n^2 + 1})} \right]$$

$$A_1 = \ln \left[ \frac{(m + \sqrt{1 + m^2})\sqrt{1 + n^2}}{m + \sqrt{m^2 + n^2 + 1}} \right]$$

$$A_2 = \frac{m}{n + \sqrt{m^2 + n^2 + 1}}$$

Where,

For center,

$$m = \frac{L}{B}$$

$$n = \frac{H}{B/2}$$

For corner,

$$m = \frac{L}{B}$$

$$n = \frac{H}{B}$$

Now from our slab data;

Breadth (B)=1.5 m

Length (L) = 24 m

Depth (D) =1.75 m

Modulus of soil( $E_s$ ) = 11.72 MPa soft clay (5-25Mpa); from Bowel Book Table 2-8.

Poisson's ratio for clay( $\mu$ )=0.30

Now for center;

$$E'_s = \frac{1 - \mu^2}{E_s} = \frac{1 - 0.3^2}{11.72} = 0.07765 \text{ m}^2/\text{MN}$$

For Center:

$$m = \frac{L}{B} = \frac{24}{1.5} = 16$$

$$n = \frac{H}{B/2} = 10 \text{ (Recommended value of } H = 5B)$$

$$B' = \frac{B}{2} = \frac{1.5}{2} = 0.75 \text{ m}$$

$$A_0 = m * \ln \left[ \frac{(1 + \sqrt{1 + m^2})\sqrt{m^2 + n^2}}{m(1 + \sqrt{m^2 + n^2 + 1})} \right] = 16 * \ln \left[ \frac{(1 + \sqrt{1 + 16^2})\sqrt{16^2 + 10^2}}{16(1 + \sqrt{16^2 + 10^2 + 1})} \right] = 0.151$$

$$A_1 = \ln \left[ \frac{(m + \sqrt{1 + m^2})\sqrt{1 + n^2}}{m + \sqrt{m^2 + n^2 + 1}} \right] = \ln \left[ \frac{(16 + \sqrt{1 + 16^2})\sqrt{1 + 10^2}}{16 + \sqrt{16^2 + 10^2 + 1}} \right] = 2.22$$

$$A_2 = \frac{m}{n + \sqrt{m^2 + n^2 + 1}} = \frac{16}{10 + \sqrt{16^2 + 10^2 + 1}} = 0.553$$

$$F_1 = \frac{1}{\pi}(A_0 + A_1) = \frac{1}{\pi}(0.151 + 2.22) = 0.755$$

$$F_2 = \frac{n}{2\pi} \tan^{-1}(A_2) = \frac{10}{2\pi} \tan^{-1}(0.553) = 0.80 ; \tan^{-1} \text{ in radian}$$

$$I_s = F_1 + \frac{1 - 2\mu_s}{1 - \mu_s} * F_2 = 0.755 + \frac{1 - 2 * 0.30}{1 - 0.30} * 0.80 = 1.212$$

$I_f = 0.88$  (guessed from Table); see Figure 46.

Foundation Analysis and Design: Dr. Amit Prasad

### Elastic settlement of Foundation

Soil Strata with Semi-infinite depth

Shape	$I_f$ Flexible Foundation			$I_f$ Rigid Foundation
	Centre	Corner	Average	
Circle*	1.00	0.64	0.85	0.86
Square	1.12	0.56	0.95	0.82
Rectangle				
$L/B = 1.5$	1.36	0.68	1.20	1.06
$L/B = 2$	1.52	0.76	1.30	1.20
$L/B = 5$	2.10	1.05	1.83	1.70
$L/B = 10$	2.52	1.26	2.25	2.10
$L/B = 100$	3.38	1.69	2.96	3.40

\*Use diameter for  $B$

27

Figure 46:  $I_f$  value. (IIT Kanpur, India)

Finally, for center;

$$k_s = \frac{1}{B'E_s m I_s I_f} = \frac{1}{0.75 * 0.07765 * 16 * 1.212 * 0.8} = 1.016 \text{ MN/m}^3 = 1016 \text{ kN/m}^3$$

Similarly, for Corners,

$$m = \frac{L}{B} = \frac{24}{1.5} = 16$$

$$n = \frac{H}{B} = 5 \quad (\text{Recommended value of } H = 5B)$$

$$B' = \frac{B}{2} = \frac{1.5}{2} = 0.75 \text{ m}$$

$$A_0 = m * \ln \left[ \frac{(1 + \sqrt{1 + m^2})\sqrt{m^2 + n^2}}{m(1 + \sqrt{m^2 + n^2 + 1})} \right] = 16 * \ln \left[ \frac{(1 + \sqrt{1 + 16^2})\sqrt{16^2 + 5^2}}{16(1 + \sqrt{16^2 + 5^2 + 1})} \right] = 0.044$$

$$A_1 = \ln \left[ \frac{(m + \sqrt{1 + m^2})\sqrt{1 + n^2}}{m + \sqrt{m^2 + n^2 + 1}} \right] = \ln \left[ \frac{(16 + \sqrt{1 + 16^2})\sqrt{1 + 5^2}}{16 + \sqrt{16^2 + 5^2 + 1}} \right] = 1.605$$

$$A_2 = \frac{m}{n + \sqrt{m^2 + n^2 + 1}} = \frac{16}{5 + \sqrt{16^2 + 5^2 + 1}} = 0.734$$

$$F_1 = \frac{1}{\pi}(A_0 + A_1) = \frac{1}{\pi}(0.044 + 1.605) = 0.525$$

$$F_2 = \frac{n}{2\pi} \tan^{-1}(A_2) = \frac{5}{2\pi} \tan^{-1}(0.734) = 0.504; \tan^{-1} \text{ in radian}$$

$$I_s = F_1 + \frac{1 - 2\mu_s}{1 - \mu_s} * F_2 = 0.525 + \frac{1 - 2 * 0.30}{1 - 0.30} * 0.504 = 0.813$$

$$k_s = \frac{1}{B'E'_s m I_s I_f} = \frac{1}{0.75 * 0.07765 * 16 * 0.813 * 0.8} = \frac{1.650MN}{m^3} = 1650kN/m^3$$

For an average value we will use weighting, consisting of four center contributions + one corner value giving,

$$k_{s,avg} = \frac{k_{s,center} + 4k_{s,corner}}{5} = \frac{1016 + 4 * 1650}{5} = 1523.2kN/m^3$$

Finally According to Bowel the value of  $k_s$  doesn't depend on the value of load bearing capacity of clay or soil.



Traffic loading calculation

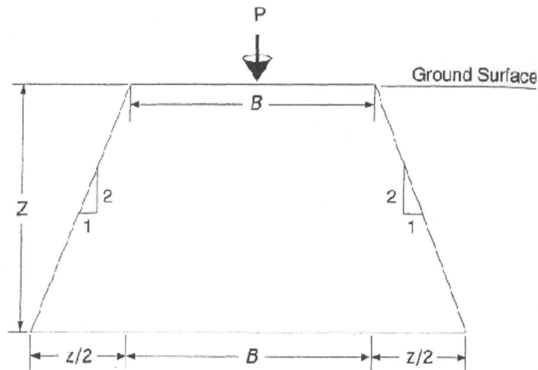

Now;

Total design traffic load =

$$\text{Design Traffic load } (-1.5m) = 1.5 * \left[ \frac{45 \text{ kN}}{0.5 * 1.5m + 0.2m + 0.5 * 1.5m} \right] \sim 40 \text{ kN/m}$$

Here, B = 0.2 is the loading area. See Figure 44.

Total Earth and self-weight:

$$\begin{aligned} \text{Design earth load + selfweight} &= 1.15 \left( 1.5m * 0.25m * 25 \frac{\text{kN}}{\text{m}^3} + 1.5m * 1.5m * 19 \frac{\text{kN}}{\text{m}^3} \right) \\ &= 60 \text{ kN/m} \end{aligned}$$

Total force on the slab due to traffic, earth and self-weight =

$$\begin{aligned} &60 * 1.25 + 100 * 1.7 + 60 * 0.1 + 100 * 1.7 + 60 * 1.25 + 2 * 60 + 100 * 1.7 + 0.1 * 100 \\ &+ 1 * 100 + 0.7 * 140 + 1 * 100 + 0.1 * 60 + 1.7 * 100 + 3.7 * 60 + 1.25 \\ &* 60 + 1.7 * 100 + 0.1 * 60 + 1.7 * 100 + 1.25 * 60 = 1988 \text{ kN} \end{aligned}$$

## Reinforcement Calculation

Maximum moment on the slab ( $M_{d,max}$ ) = 51kNm ,with support

For total number of rebar required in the slab,

We have,

Maximum design Moment( $M_{d,max}$ ) = 51kNm

Tensile mean value( $f_{ctm}$ ) = 2.9 Mpa

Characteristics compressive strength( $f_{yk}$ ) = 500N/mm<sup>2</sup>

$$C_{nom} = 50mm$$

Concrete C30/37

$$F_{cd} = \left( \frac{0.85 * 30Mpa}{1.5} \right) = 17N/mm^2$$

$$F_{ctd} = \frac{2Mpa}{1.5} = 1.34 \frac{N}{mm^2}$$

$$d = 250mm - 50mm - 12/2 = 194mm$$

Now,

$$\text{Relative moment}(\mu) = \frac{M_{d,max}}{b * d^2 * f_{cd}} = \frac{51}{1m * (0.194)^2 * 17 * 10^3 \frac{kN}{m^2}} = 0.079$$

Again,

$$\beta = 1 - \sqrt{1 - 2\mu} = 0.083 < 0.2 \quad OK$$

$$z = d \left( 1 - \frac{\beta}{2} \right) = 194 \left\{ 1 - \frac{0.067}{2} \right\} = 185.93mm$$

$$(F_{yd} = \frac{f_{yk}}{\gamma_s} = \frac{435N}{mm^2})$$

Area of rebar per meter  $A_s = \frac{M_{d,max}}{Z * f_{yd}} = \frac{51 * 10^6 \text{ Nmm}}{185.93 \text{ mm} * 435 \frac{\text{N}}{\text{mm}^2}} = 630.56 \frac{\text{mm}^2}{\text{m}}$

Now,

$$A_{s,min} = \max \left[ \begin{array}{l} 0.26 * \frac{f_{ctm}}{f_{yk}} * b * d = 0.26 * \frac{2.9}{500} * 1000\text{mm} * 194\text{mm} = 292.552 \frac{\text{mm}^2}{\text{m}} \\ 0.0013 * b * d = 252.2 \frac{\text{mm}^2}{\text{m}} \end{array} \right]$$

Hence,

$$A_{s,min} = 292.552 \frac{\text{mm}^2}{\text{m}}$$

But,

$$A_{s,min} < A_s$$

Hence,

$$A_s = 630.56 \text{mm}^2 / \text{meter}$$

We chose T12 rebar so,

$$\text{Spacing}(S) = \frac{1000 * 113 \text{mm}^2}{630.56} = 179.20 \text{mm}$$

So we chose spacing 150 mm

Now,

$$\text{Total number of T12 rebar required} = \frac{1500\text{mm} - 30\text{mm} - 30\text{mm}}{150\text{mm}} = 9.33$$

We choose 10.

## Calculation of Shrinkage

From EuroCode we know that;

Total shrinkage =Autogenous Shrinkage+ Drying Shrinkage

$$\varepsilon_{cs} = \varepsilon_{ca} + \varepsilon_{cd}$$

Where,

$\varepsilon_{ca}$ = Autogenous Shrinkage

$\varepsilon_{cd}$ =Drying Shrinkage

Autogenous Shrinkage

$$\varepsilon_{ca}(t) = \beta_{as}(t) * \varepsilon_{ca}(\infty)$$

Where,

$$\varepsilon_{ca}(\infty) = 2.5 * (f_{ck} - 10) * 10^{-6} = 5 * 10^{-5} \quad (f_{ck}=30\text{Mpa})$$

$$\beta_{as}(t) = 1 - e^{(-0.2*\sqrt{t})}$$

For t=365 days

$$\beta_{as}(365) = 1 - e^{(-0.2*\sqrt{365})} = 0.97$$

Hence,

$$\varepsilon_{ca}(365) = \beta_{as}(365) * \varepsilon_{ca}(\infty) = 4.89 * 10^{-5} \text{mm}$$

Drying Shrinkage

$$\varepsilon_{cd}(t) = \beta_{ds}(t, t_s) * k_h * \varepsilon_{cd,0}$$

Where,

$$\varepsilon_{cd,0} = 0.85 * \left[ (220 + 110 * a_{ds1}) * e^{\left[ -a_{ds2} * \frac{f_{cm}}{f_{cmo}} \right]} \right] * 10^{-6} * \beta_{RH}$$

$$\beta_{RH} = 1.55 \left[ 1 - \left( \frac{RH}{100} \right)^3 \right] \sim 0.80 \quad RH=80\%$$

We have,

$$f_{cm} = 38\text{Mpa}; \text{ For Concrete C30/37}$$

$$f_{cmo} = 10\text{Mpa}$$

$$\alpha_{dis1} = 4 \text{ (Class N)}$$

$$\alpha_{dis2} = 0.12 \text{ (Class N)}$$

Now,

$$\varepsilon_{cd,0} = 0.85 * [(220 + 110 * 4) * e^{-0.12*3.8}] * 10^{-6} * 0.80 = 2.84 * 10^{-4}$$

Let's consider drying shrinkage begins at the first day so,  $t_s = 1$

$$\beta_{ds}(t, t_s) = \frac{t - t_s}{(t - t_s) + 0.04 * \sqrt{0.73}} = 0.99$$

$$h_0 = \frac{2A_c}{u}$$

where,  $A_c$ =Cross section Area and  $\mu$ =Perimeter of cross section

Hence,

$$h_0 = \frac{2(0.25 * 1.5)}{2(1.5 + 0.25)} = 0.214\text{m} = 214\text{mm}$$

From table Table 2: Values of  $k_h$

$$k_h = 0.85$$

Now,

$$\text{Drying shrinkage strain} = \varepsilon_{cd}(t) = \beta_{ds}(t, t_s) * k_h * \varepsilon_{cd,0}$$

$$\varepsilon_{cd}(t) = 0.99 * 0.85 * 2.84 * 10^{-4} = 2.38 * 10^{-4} \text{mm}$$

$$\text{Finally, Total shrinkage} = \varepsilon_{cs}(t) = 4.89 * 10^{-5} + 2.38 * 10^{-4} = 2.86 * 10^{-4} \text{mm}$$

For infinite time,

$$\beta_{cs}(\infty) = 1$$

$$\beta_{ds}(\infty, t_s) = 1$$

$$\varepsilon_{ca}(\infty) = 5 * 10^{-5}$$

$$\varepsilon_{cd}(\infty) = 1 * 90.7 * 2.69 * 10^{-4} = 1.88 * 10^{-4} \text{mm}$$

Total shrinkage at infinite time

$$\varepsilon_{cs}(\infty) = \varepsilon_{ca}(\infty) + \varepsilon_{cd}(\infty) = 2.38 * 10^{-4} \text{mm}$$

## Crack Width calculation

From EuroCode we know the formula of crack width is;

$$W_k = S_{r,max}(\epsilon_{sm} - \epsilon_{cm})$$

Where,

$W_k$  = crack width

$$S_{r,max} = k_3c + k_1k_2k_4 \frac{\sigma}{\rho_{p,eff}}$$

$S_{r,max}$  = Maximum Crack spacing

$\epsilon_{sm}$  = Mean strain in the reinforcement under the relevant combination of loads, including the effect of imposed deformations and taking into account the effects of tension stiffening. Only the additional tensile strain beyond the state of zero strain of the concrete at the same level is considered

$\epsilon_{cm}$  = Mean strain in the concrete between cracks

$\epsilon_{sm} - \epsilon_{cm}$  may be calculated from the expression:

$$\epsilon_{sm} - \epsilon_{cm} = \frac{\sigma_s - k_t \frac{f_{ct,eff}}{\rho_{p,eff}} * (1 + \alpha_e * \rho_{p,eff})}{E_s} \geq 0.6 * \frac{\sigma_s}{E_s}$$

Where,

$$\alpha_e = \frac{E_s}{E_{cm}} = \frac{200}{33} = 6.06$$

$E_s$  = Design value of elastic modulus of reinforced steel = 200 Gpa

$E_{cm}$  = Secant modulus of elasticity of Concrete = 33 Gpa

$k_t = 0.4$  (Long term loading)

$$f_{ct,eff} = f_{ctm} = 2.9 \text{ Mpa}$$

$$b * x * \frac{x}{2} = \frac{E_s}{E_{c,eff}} * A_s * (d - x)$$

$$E_{c,eff} = \frac{E_{cm}}{1 + \phi(\infty, t_0)}$$

Where,

$\phi(\infty, t_0)$  = creep coefficient = 2.5 From graph

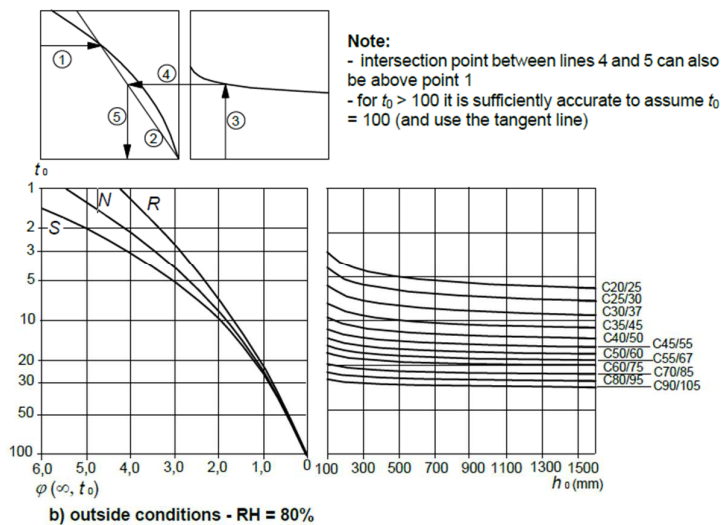

$$E_{c,eff} = \frac{33}{1 + 2.5} = 9.428 \text{ kN/mm}^2$$

Now,

$$b * x * \frac{x}{2} = \frac{E_s}{E_{c,eff}} * A_s * (d - x)$$

$$750\text{mm} * x^2 = \frac{200}{9.428} * 630.56\text{mm}^2 * (194\text{mm} - x)$$

By equating above equation we get,

$$x = 50.5764\text{mm}$$



$$A_{c,eff} = h_{eff} * b$$

Where,

$$h_{eff} = \min(2.5 * (h - d); (h - x)/3; 0.5h)$$

$$h_{eff} = \min(2.5 * (250 - 194); (250 - 50.576)/3; 0.5 * 0.5 * 250)$$

Therefore,

$$h_{eff} = 66.47mm$$

Then,

$$A_{c,eff} = 66.47 * 1500 = 99712mm^2$$

$$\rho_{p,eff} = \frac{A_s}{A_{c,eff}} = \frac{630.56mm^2}{99712mm^2} = 0.0063$$

$$\sigma_s = \frac{M}{\left(d - \frac{x}{3}\right) * A_s} = \frac{51 * 10^6}{\left(194 - \frac{50.576}{3}\right) * 630.56} = 456.58N/mm^2$$

Now,

$$\begin{aligned} \varepsilon_{sm} - \varepsilon_{cm} &= \frac{\sigma_s - k_t \frac{f_{ct,eff}}{\rho_{p,eff}} * (1 + \alpha_e * \rho_{p,eff})}{E_s} \\ &= \frac{456.58Mpa - 0.4 * \frac{2.9Mpa}{0.0063} * (1 + 6.06 * 0.0063)}{200000Mpa} \end{aligned}$$

Equating above equation,

We get,

$$\varepsilon_{sm} - \varepsilon_{cm} = 0.00132$$

Now,

$$S_{r,max} = k_3c + k_1k_2k_4 \frac{\emptyset}{\rho_{p,eff}}$$

Concrete cover( $c$ )=50mm

Bond factor( $k_1$ ) = 0.44 (NA)

Strain distribution coefficient( $k_2$ ) = 1.10 (NA)

Bar diameter( $\phi$ ) = 12mm

$k_3 = 3.4$

$k_4 = 0.425$

Now,

$$S_{r,max} = 3.4 * 50mm + 0.425 * 0.44 * 1.10 * \frac{12mm}{0.0063} = 561.80 mm$$

Finally,

$$W_k = 561.80mm * 0.00132 = 0.74mm \leq 0.6 * \frac{\sigma_s}{E_s}$$

$$0.74mm \leq 0.6 * \frac{456.58}{200}$$

0.74mm  $\leq$  1.36 ok