

The Energetic Playground

A feasibility study applying energy sources on a Playground: Green Energy alternatives

Daniel Rey Sisó

'In times of crisis, only imagination is more important than knowledge.'

Albert Einstein

Degree Thesis for Bachelor of Engineering

Degree Programme in Energy and Environmental Engineering

Vaasa, Finland 2016

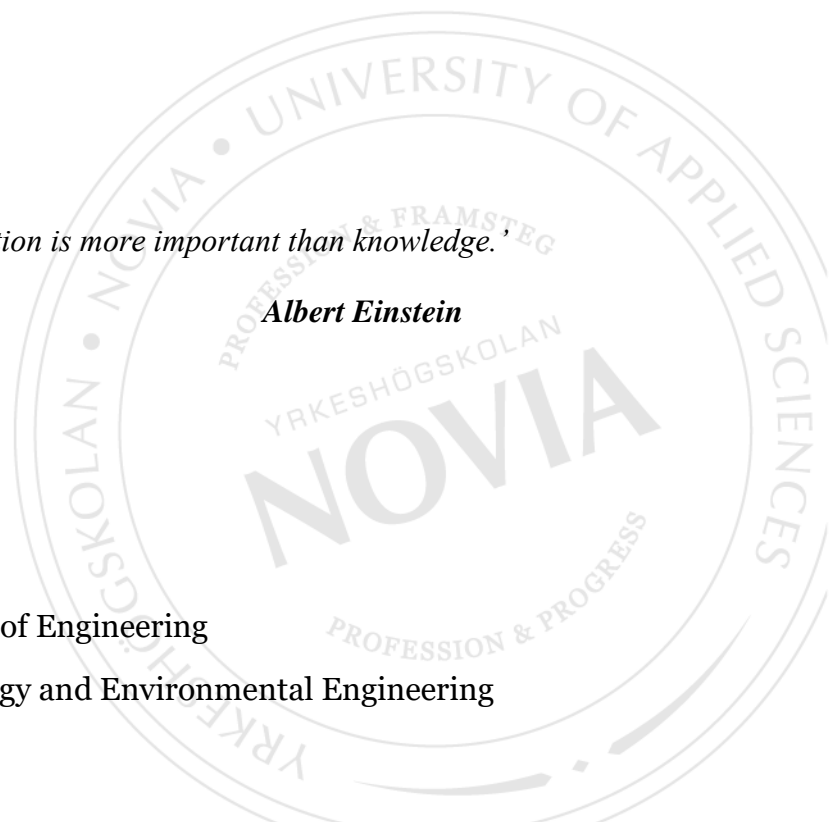

BACHELOR'S THESIS

Author: Daniel Rey Sisó

Degree Program: Energy and Environmental Engineering

Specialization: Mechanical Engineering (University of Lleida, Spain)

Supervisors: Charlotta Risku

Title: **The Energetic Playground**

Date: 22/04/2016

Number of pages: 93

Abstract

This thesis aims to study the feasibility of using energy generated by the physical activity of children playing in playgrounds. More particular, the goal is to generate clean energy by playing games and showing them the effort about how energy is produced.

The ease of turning on lights or using electrical appliance by simply pushing one button causes unawareness of the actual effort and negative impacts of the generation, transmission and distribution behind energy sourcing. The idea of this study arises from the concern of the damage that has already been caused to the environment by the excessive use of the main energy resources. The different prototypes presented in the following document are based on the mechanical swing operation, merry-go-round and the piezoelectric tiles; energy sources that are not typically utilized on this matter. The intention is the usage of human mechanical force, in this case the physical activity of children, to generate electric current, which would be stored, sent to the grid or used directly in parks at night or in surrounding houses.

The main idea behind this project is to change the view on energy generation in order to avoid further environmental damage. To ensure long-term success children must be well educated e.g.: by designing an educational municipal or local playground, where they can gain first-hand insights of the process of energy production while they are playing, losing weight and feeling good with themselves.

Language: English / Key words: Environmental, sustainable, mechanical, new alternatives.

PREFACE

The presented thesis has been carried out to obtain the Double Degree title in Environmental Engineering and Mechanical Engineering. The main topic is based on a feasibility study of to generate clean electricity with energy derived from the physical activity of children in playgrounds in parks or schools.

This project showed a good way to pair both bachelor programs. On the one side, this project used previously acquired mechanical knowledge such as calculations and physics theories, and software's like *SolidWorks 3D CAD and AutoCAD*. On the other side, in the field of Environmental and Renewable Energies are the concepts about renewable resources as well as several concepts that have been applied to ensure a cleaner and more efficient way of energy production. Furthermore, it shows a 'green vision' to generate electricity for the population.

This thesis has been divided into two parts.

The **First Part** contains **General Introduction** collected in three chapters.

Chapter 1 introduces the main concept of Energy and Energy as a Resource.

In **Chapter 2 and 3** the main topics of this project are developed, as which mechanisms are going to use in the designs.

The **Second Part** contains the main objectives of this project and three more chapters that collect the **Research work**.

Chapter 4 shows the first mechanism of entertainment for children: The electrical generator Swing which the design of it is explained.

The **Chapter 5** is about the mechanism known as: Merry-Go-Round that explains the function of the design of the mechanism, which collects electrical Energy to use directly or to store it.

Chapter 6 looks on a different way to gain energy from the habitants such as when they are walking.

Finally, the final conclusions are listed of the investigation project and the appendixes.

'The Earth provides enough to satisfy every man's need but not for every man's greed.'

Mahatma Gandhi

Table of contents

1. INTRODUCTION.....	1
2. PROBLEM STATEMENT	3
3. ENERGY	5
3.1. ENERGY AS A RESOURCE	5
3.2. HOW IS ELECTRICITY GENERATED?	6
4. MECHANISM FOR ENERGY CONVERSION	7
4.1. SPEED MULTIPLIER	7
4.2. DRIVESHAFT OR PROPELLER SHAFT.....	8
4.2.1. <i>Loads on the driveshaft</i>	9
4.3. ROLLER BEARING.....	9
4.4. DRAWN CUP ROLLER CLUTCHES	12
4.5. GEARS.....	12
4.5.1. <i>Synchronous generators</i>	14
5. ENERGY-GENERATOR SWING.....	15
5.1. INTRODUCTION TO THE ENERGY-GENERATOR SWING	16
5.2. THEORETICAL BASES	18
5.2.1. <i>Conservative forces</i>	18
5.2.2. <i>Potential energy due to the gravitational field</i>	19
5.3. DESIGN OF THE ELECTRICAL GENERATOR SWING	20
5.4. FIRST STEP: ENERGY BALANCE	20
5.5. SECOND STEP: REACTIONS ON THE COGWHEEL	22
5.6. THIRD STEP: DESIGN OF THE DRIVESHAFT	23
5.6.1. <i>Calculation of the roller bearings</i>	24
5.6.2. <i>Study and calculation of the driveshaft</i>	29
5.6.3. <i>Calculation of the fatigue resistance on the driveshaft</i>	33
5.7. REMODELING AND SELECTION OF THE COMPONENTS	35
5.8. ESTIMATION OF THE POWER OUTPUT.....	37
5.9. CONCLUSIONS.....	38
6. MERRY-GO-ROUND MECHANISM	39
6.1. INTRODUCTION TO MERRY-GO-ROUND	39
6.2. DESIGN	40
6.2.1. <i>Level 1 Block diagram</i>	40
6.2.2. <i>Level 2 Block diagram</i>	40
6.3. ELECTRIC CIRCUIT ESTIMATIONS.....	41
6.4. FINANCIAL STUDY.....	43

6.5. HARDWARE.....	44
6.6. MATERIAL AND ELECTRONIC EQUIPMENT	44
6.6.1. <i>Ac Dynamo Generator</i>	44
6.6.2. <i>AC-DC Rectifier</i>	45
6.6.3. <i>Boost Convert Module</i>	47
6.6.4. <i>Buck Converter module</i>	48
6.7. CONCLUSIONS AND RECOMMENDATIONS	50
7. OTHER WAYS OF CAPTURING HUMAN KINETIC ENERGY	51
7.1. INTRODUCTION	51
7.2. ANTECEDENTS	51
7.3. PIEZOELECTRICITY	54
7.4. INTRODUCTION TO THE PIEZOELECTRIC PHENOMENON	54
7.5. PIEZOELECTRIC MATERIALS PROPERTIES.....	54
7.6. PIEZO GENERATORS	55
7.6.1. <i>One layer piezo generators</i>	55
7.6.2. <i>Multi layers Piezo Generators</i>	55
7.7. USE THE PIEZOELECTRIC TILES TO HARVEST ENERGY.....	56
7.7.1. <i>Introduction</i>	56
7.7.2. <i>Principle of the operation of the piezoelectric tiles</i>	56
7.8. DESCRIPTION OF A PIEZOELECTRIC TILE POWERLEAP	57
8. RESULTS AND CONCLUSIONS	58
APPENDIX 1	II
1.1 LOW-TECH SYSTEM. PROJECT SWING / MORADAVAGA	II
1.2 CALCULATION OF THE DIMENSIONING ON REQUEST DYNAMIC OF ROLLER BEARINGS.	III
1.3 CALCULATION OF THE DIMENSIONING ON REQUEST DYNAMIC OF ROLLER CLUTCHES.....	III
1.4 DIMENSIONING THE DIAMETER OF THE DRIVESHAFT AT POINT B.	IV
1.5 CALCULATIONS IN EXCEL AT POINT B	VII
1.6 DIMENSIONING THE DIAMETER OF THE DRIVESHAFT AT POINT C.	IX
1.7 CALCULATIONS IN EXCEL AT POINT C	XII
1.8 MATERIALS SELECTED	XIV
APPENDIX 2	XVIII
2.1 MATERIALS SELECTED	XVIII

First part. General Introduction

1. Introduction

Generating clean electricity is constantly developing through multiple projects and new mechanism operating around the world. Despite this, the use of these mechanisms is still in process. Gradually, these mechanisms are more frequently developed in more and more countries. The majority of these projects are still in the design stage, but it can be seen that these have already been applied in underdeveloped countries, for example in Africa.

It is generally known that children have unlimited energy. This energy could be used in a different way than just having a good time or running. We have often heard that children never get tired of playing and adults usually demand them to sit still and not to disturb, however what would happen if the energy that children use playing is harnessed to generate electricity? The idea is to use children's playgrounds outdoors or in local elementary schools to produce energy in form of electricity.

First of all, a study to design a model of a traditional swing which could generate either electricity in alternate current (AC) or continues current (DC), depending on the use that is wanted, like for example the main purpose, illuminate the parks (AC) has to be made.

Next, there is the design of a traditional merry-go-round that can produce electricity in both ways. There are many projects related to this children game, many of them in underdeveloped countries. Nowadays it is still built in Africa, to provide electricity for flashlights enabling children to study at night.

Nevertheless, this project about the merry-go-round focuses on trying to generate electricity either in DC to charge mobiles, tablets, etc. or in AC to help to illuminate the municipal or school playground. Finally, a more recent technology is in continuous development for many companies, piezoelectric tiles are studied. A design with these piezoelectric plates is presented, covering the entire playground floor to generate electricity.

Furthermore, it has a positive influence on the children's live by designing an educational municipal or local playground where they can feel involved in the process of producing energy while they are playing, losing weight and feel good with themselves.

Constantly, media says that children are the future. This thesis takes advantage of these words making this project to increase the general motivation of the people. Here, producing energy in a useful mode while keeping the users enjoying their time.

Thinking about that approximately one calorie is equal to 4.18 Joules (J), and one child tends to generate roughly 2200 calories/day, this is fascinating from a perspective of energy sourcing, although much of these calories are used for biological functions. This project is associated with energy and how it is possible to source energy in a clean way, but “What does energy mean?”

Energy is defined as a property associated with the substances and objects that are appearing in the transformation. These occur in nature, in physical changes such as transport, lift, deforming, heat an object or chemical changes such as melting a piece of ice.

The main sources of energy of our ancestors were the strength of men and animals, however with their ingenuity they developed some machines to take advantage for grind. For example the cereal with the hydraulic force, obtain heat by burning wood, windmills etc. The big revolution came with the steam engine from the industrial revolution, where the large-scale usage of enormous amount of energy contained in renewable and non-renewable resources started.

2. Problem Statement

Actually the human requires energy to survive, manage their environment and produce goods¹. For some time now, the world is watching all the energetic problems due to the depletion of the world oil reserves, which are used as a direct source of energy (engines of automobiles or others) or to generate other energy as electric. This phenomenon has been termed as 'energy crisis'.

The reasons are various: the consumption of electrical energy due to the constant growth of the industrial and the residential sector. These have the highest amount of energy demand and exploit natural resources most. To face this crisis the necessity to take advantage in the best way has emerged. The available energy resources currently generate new ways of making better use of available natural resources to transform into energy.

It is known that almost all types of energy comes indirectly from the sun. For example, wind energy is caused by energy kinetics of solar radiation which produces a difference pressure between the differences temperature of the air masses. Fossil fuels or hydrocarbons come from energy transmitted by the sun and the decomposition process in the absence of oxygen of plant species, which inhabited the earth millions of years ago. There are two large groups of energy sources, which are renewable and nonrenewable.

The non-renewable energies (petrol, coal, natural gas or uranium principally) are from sources that are depleted, such as uranium, gas fields, coal and oil. Once out they cannot regenerate or take too long to do so. Renewable energies are those that are non-exhausted, such as the sun's energy, wind energy, the energy produced by the gravitational pull of the moon (tidal power), the energy of the earth (geothermal energy), etc.

After the industrial revolution, humans turned largely to the use of fossil fuels (natural gas, coal and oil), which have been used in high amounts because of its high efficiency considering its energy transformation.

However, many of these fuels pose serious environmental problems, as they emit toxic or polluting gases into the Earth's atmosphere harming life. Additionally, as fuel fossils begin to dwindle in the future, these will rise in price according to offer and demand. Many countries have tried to reduce their dependence on fossil fuels through research into sources of "green" or renewable energy to reduce the heavy pollution that exists today. Hence, today's fossil fuels are the prime energy source on the planet.

¹ Roman L, (2006).

Globally, all these fuels: oil, coal and natural gas, represent 78% of the total consumption. Approximately one third of the primary energy is used to produce electricity. Also 40% of the electricity comes from coal, while oil and nuclear energy only cover between 12% and 15% each. In terms of energy consumption, electricity accounts for 12% of the total consumption equally the industrial and residential sectors.

A quarter of the world population consumes three quarters of the total primary energy in the world. These inequalities are more significant, considering electricity consumption. Poor countries (characterized by a dispersed habitat) exhibit large gaps in rural electrification. Nowadays, we have a huge population that demands large amounts of energy. Consequently, there is the necessity to make certain changes which generate development, but these in turn are hand in hand with the sustainability of the planet.

The proposal of this thesis aims to deepen the issue of power generation by the mechanical energy that people can produce, in which has been working in recent years on other projects.

These sources of cleaner energy than fossil fuels have the advantage that they are not exhausted, as this energy is produced by our own efforts. For this reason the awareness of the people could be improved by offering opportunities to learn the fundamentals of energy, e.g.: through the mechanisms in the playground it can be showed how the work performed by a human is harvested, stored and used.

The green technology could be the biggest opportunity in the 21th century

John Doerr

3. Energy

Energy is a property of the matter which is the ability to perform work or produce transformations. Any material body passing from one state to another, produces physical phenomena that are nothing more than manifestations of this property. Therefore, it can be in various forms to be transformed from one energy state to another.

Energy can manifest itself in different forms: gravitational, kinetic, chemical, electrical, magnetic, nuclear, calorific, etc., with the possibility of transforming each other with respect of the principle of conservation of energy.

The principle of energy conservation: Energy can neither be created nor destroyed; rather, it transforms from one form to another.² Practically all the energy has come from the sun. The sun produces wind, surface water evaporation, cloud formation, rainfall, etc. Its heat and light are the basis of many chemical reactions for the development of plants and animals, whose remains over centuries originate to fossil fuels such as coal, oil and natural gas.

3.1. Energy as a resource

Energy sources are existing resources from nature, which humanity can derive usable energy from. The origin of almost all types of energy is the sun.

Energy sources that regenerate naturally and bring the idea of being "clean" are called renewable energy sources or alternatives. These can become non-renewable sources if the level of consumption is higher than their regeneration capacity. Some sources of this type are:

- Hydro power
- Geothermal
- Bioenergy
- Solar
- Wind

In contrast, it is understood by non-renewable sources, those involving the consumption of exhaustible resources and energy contaminants. Some examples are:

- Petroleum
- Coal
- Nuclear fission Generation

² **Conservation of Energy.** McGraw-Hill Dictionary of Scientific & Technical Terms, 6E, Copyright © 2003 by the McGraw-Hill Companies, Inc.

Energy availability of renewable energy is higher than of non-renewable energy, but its use is limited. The development of technology, increasing social demand, lower installation costs and fast amortization are driving greater use of sources of energy from renewable sources in recent years.

3.2. How is electricity generated?

Currently, most of the electricity is produced by burning fossil fuels like oil, coal, natural gas, etc. Part of the energy comes from the nuclear power plants and big dams. To understand why clean energy is needed to replace fossil fuels and nuclear power plants, it should be understood how electricity is produced from renewable sources or from polluting sources.

Most of the electricity produced by fossil fuels is produced when the energy source heats water to produce steam and this steam turns the big turbines to produce electricity, different from the big hydroelectric dams which are not fossil fuels. The hydro power is used in a different way to produce energy: the waterfalls spin the turbines to produce electricity. All these techniques of energy production result in toxic pollution, destruction of communities (dams) and many serious health problems. None of these options are healthy or sustainable, especially when used in a large scale.

The fossils fuels become scarcer every day and more difficult to find. They are not renewable which means that once used, they will be exhausted. At the same time, the danger of the climate change and pollution from burning fossil fuels has become a higher environmental health problem.

If the clean energy is used, it is possible to reduce the damage that the fossil fuels and other pollutant technologies for the non-renewable energy production cause to the human health and the environment. Clean energy renewable sources can provide electricity without causing damage.

4. Mechanism for Energy conversion

In this chapter the following mechanisms can be applied to the prototypes that will be explained in the second part of this project. This mechanisms are explained considering that in the prototypes are going to be use to get electricity from mechanical energy by the children.

4.1. Speed multiplier

This gear uses the mechanism to transmit mechanical power between different parts of a device. It serves to transmit circular movements by sprockets in contact. One of the most important applications is the transmission of motion from the shaft of a power source, to another shaft located at some distance that still has to perform work.

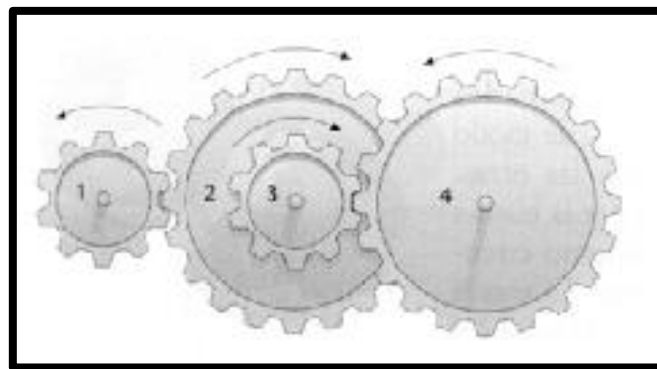

Figure 1. Speed multiplier.³

A speed multiplier is a transmission system formed by gears. It characterizes that the output speed is higher than the input. It is an opposite system to the speed reducer, because in most cases the speed of the motors spin is more than adequate for the work in machines. It is similar than a speed reducer but with the difference in the input shaft and the output. The efficiency of this device can reach from 90% to 97%.

If we look the figure 7, the N_i (number of the teeth) and D_i , with $i = 1, 2, 3, 4$, the angular velocities and the diameters for the gears 1, 2, 3 and 4. Then it holds that:

$$D_1 N_1 = D_2 N_2 \text{ (Equation 3.1)}$$

$$D_3 N_3 = D_4 N_4 \text{ (Equation 3.2)}$$

³ Source. http://iet-journals.org/archive/2014/april_vol_4_no_4/8213113821526.pdf

$$N_2 = N_3 \text{ (Equation 3.3)}$$

$$N_1 = \frac{D_2 D_4}{D_1 D_3} N_4 = k N_4 \text{ (Equation 3.1)}$$

To conclude, if the factor k is greater than 1, the gear arrangement represents a speed multiplier in case the input to the system is given at the gear shaft $n^{\circ}4$.

4.2. Driveshaft or propeller shaft

A driveshaft is a shaft that transmits a driving force and it is subjected to some torque effort because of the transmission of couple of forces, as it might be subject to other types of mechanical stresses at the same time.



Figure 2. Driveshaft or propeller shaft. ⁴

A propeller shaft is a rotating member that is used to transmit the rotatory movement and power between coaxial transmission elements, such as flywheels, gears, pulley, etc. The driveshaft also transmit around the rotating members such as crank. Generally, it has a revolution form and a section in the diameter smaller than its length.

⁴ Source. *Teoría de Mecanismos - Arbre de transmissió*. University of Lleida (UDL)

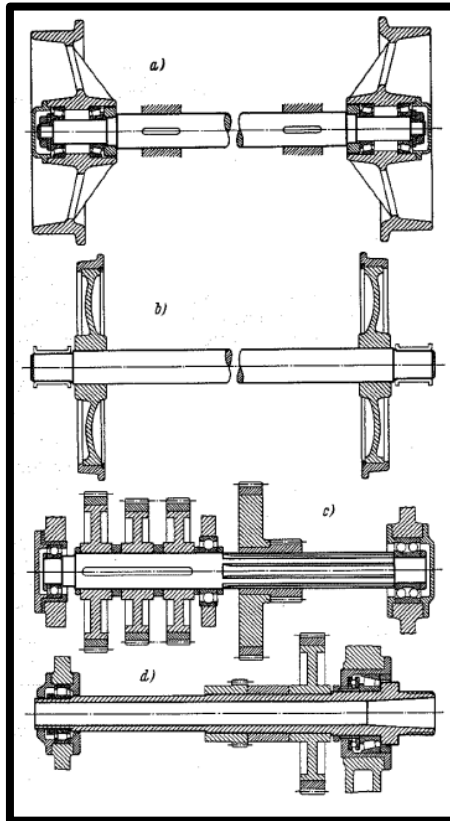

Figure 3. a) Fix solid shaft; b)Rotatory solid shaft; c)Solid shaft; d)Gap shaft.⁵

4.2.1. Loads on the driveshaft

Generally, in the driveshaft analysis the structural point of view looks at the beams of constant section or variables around its symmetric shaft. The different types of efforts in the driveshaft are:

- Torsion. Caused by the torque that is transmitted between the different elements coupled with the driveshaft. (Pulley, gears, etc.)
- Bending. Caused by force components perpendicular to the shaft (tangential or radial), in the transmission elements, weight, roller bearing, etc.
- Shear strength. Caused by the same force as in the bending efforts.
- Axial. Caused by the loads parallel in the shaft direction.

4.3. Roller bearing

Definition. The Roller bearing is an element consisting of two concentric rings (two rolling surface with rolling elements in contact these), in order to allow the rotational movement of one ring over the other around their common axis.

⁵ Source. *Teoría de Mecanismos - Arbre de transmissió.* University of Lleida (UDL)

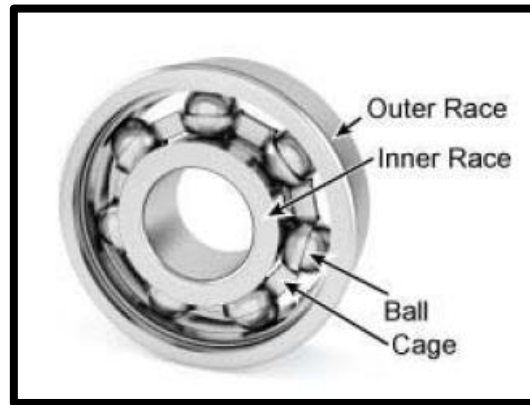

Figure 4. Roller bearing.⁶

Advantages

- The bearing allows a lower friction torque between the rings even with high loads.
- It can have no movement assembling the balls under pressure with some theoretical interference with the surfaces.
- High load capacity.
- Minimum wear.
- Easy replacement.
- Relatively low cost, mainly with the most common types.

Classification

- Cylindrical roller
- Spherical roller
- Gear bearing
- Tapered roller
- Needle roller
- CARB toroidal roller bearing

Classification according to the contact direction

- Thrust loadings. Support axial loads.
- Radial loadings. Support radial loads.
- Linear motion. Support axial and radial loads.

⁶ Source. Teoría de Mecanismos - Rodamentos. University of Lleida (UDL)

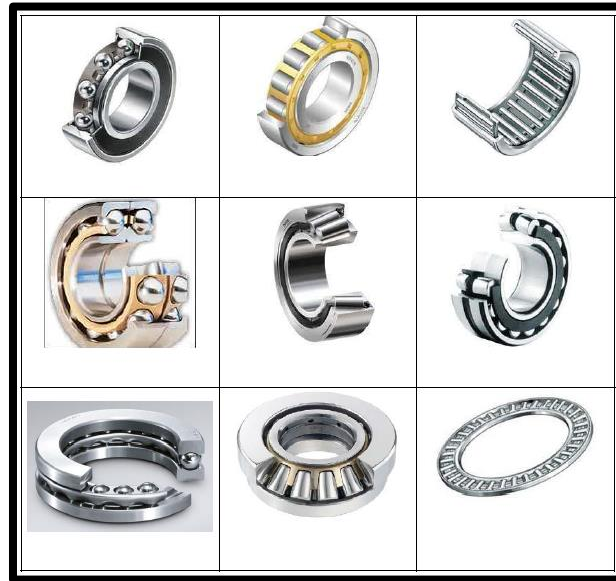

Figure 5. Roller bearing classification ⁷

Loads that can support the different types of the Roller bearing

- Axial load (F_a)
- Radial load (F_r)
- Bending moment load (M_f o M_b)

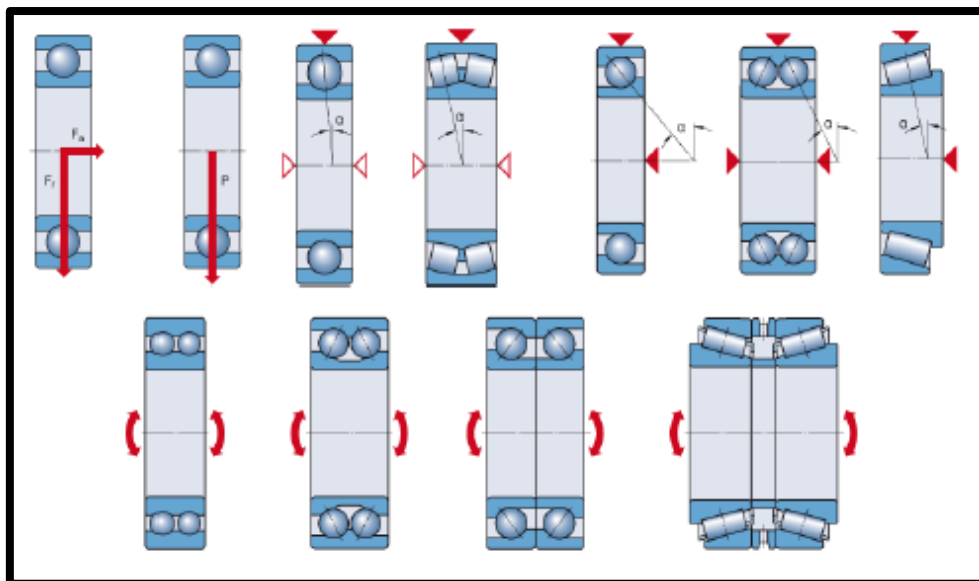

Figure 6. Different loads that can support the Roller bearing. ⁸

⁷ Source. Teoría de Mecanismos - Rodamentos. University of Lleida (UDL)

⁸ Source. Teoría de Mecanismos - Rodamentos. University of Lleida (UDL)

4.4. Drawn cup Roller clutches

The drawn cup roller clutches are considering bearing assemblies, these type of bearings have the function to transmit the torque, to the shaft, in one direction between the housing and shaft, and allow free rotation in the opposite direction.

The roller clutches selected for the electrical generator swing (see chapter 4) have the same small radial section as the cylindrical roller bearing. Further, it is easily adapted to the shaft; these designs are pressed in it.



Figure 7. Drawn cup roller clutch.⁹

4.5. Gears

Definition. It is a combination of two gears that mesh with each other, so that they can transmit motion and force in a different way.

Functionality. Rotational movement transmission between two shafts, with a relation between the angular velocities of these constant throughout the movement.

Particularities and characteristics of the gears

- Relation between the velocities
- No limited by friction in contact

Advantages and disadvantages

Table 1. Advantages and disadvantages of the gears

Advantages	Disadvantages
No sliding → High torque capacity	Complex manufacturing → High cost
No sliding → Synchronization	Requires high precisions forms
Regularity of operation	Need lubrication (not all)
Less maintenance	More noise than belts
Allow high speeds	Do not avoid overloading

⁹ Source. <https://www.fastenal.com/products/details/4121798>

Types of gears according to the relative position of the shaft

- Parallel shaft. Cylindrical gears. It is the gear rack and pinion, where the rack could be considered a wheel of infinite radius.
- Intersecting shafts. Conical gears.
- Intersecting shafts in the space. Helical gears, hypoid gears and worm gear.

Types of gears according the tooth

- Straight teeth
- Helical teeth
- Double helical

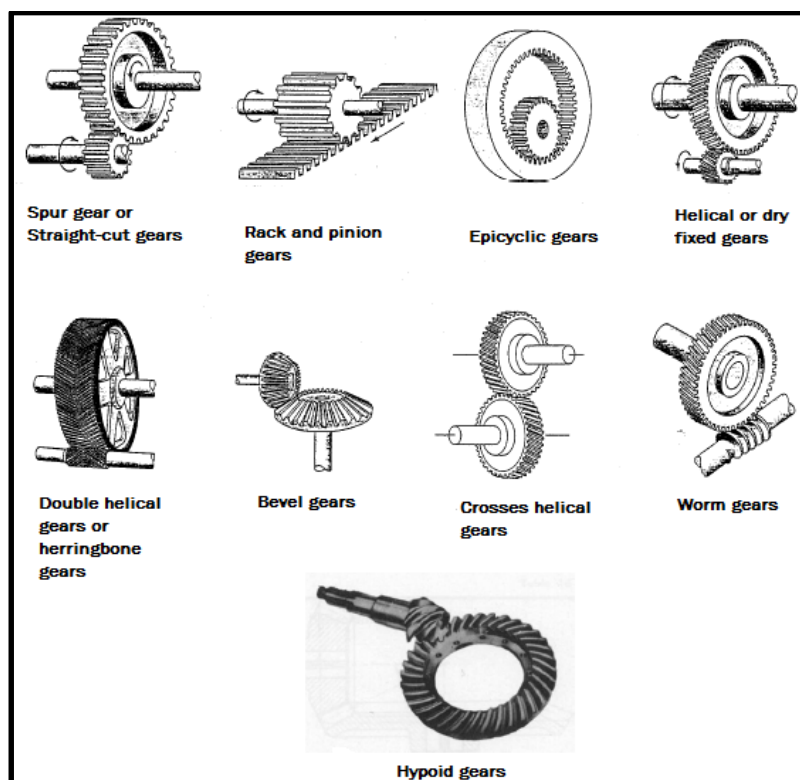

Figure 8. Different types of gears. ¹⁰

Applications of the gear which is going to be used

Cylindrical gears.

- It is cheapest, and therefore most used.
- The function, according to the regularity, is quite good.
- Very high performance.

¹⁰ Source. Teoría de Mecanismos - Engranatges. University of Lleida (UDL)

Table 2. Efficiency of the gears. ¹¹

Quality and lubrication of the gears	Efficiency
Dirty teeth without machined	0.9 ... 0.92
Machined flanks of the teeth and lubricated	0.94
Machined flanks of the teeth with precision and lubricated	0.96

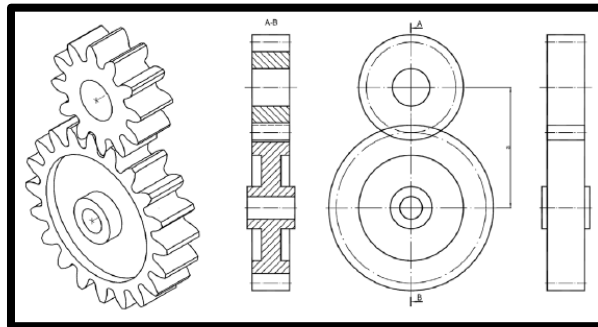

Figure 9. Representation of a cylindrical gear with straight teeth. ¹²

4.5.1. Synchronous generators

The synchronous generators (alternator) is a type of rotating electric machine able to transform mechanical energy into electrical energy. This generator is mainly composed of a moving part or rotor and a fixed part or stator, the principle working of a synchronous generator is based on the Faraday's law, explained above.

In the rotor, an electrical current (DC) is inducted to create a magnetic field, when the rotor is rotating by a gear for example; it generates a magnetic field, which induces a potential difference in the stator that will create the electrical current (AC).

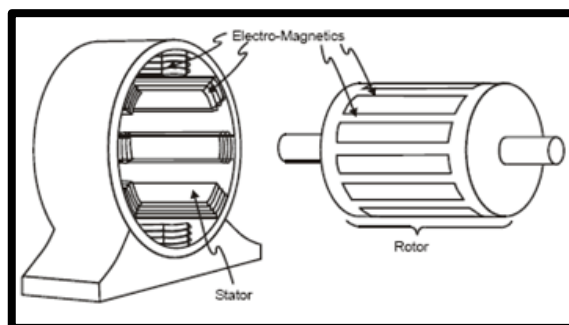

Figure 10. Rotor and stator. ¹³

¹¹ Source. K. H. Decker, Elementos de máquinas

¹² Source. Teoría de Mecanismos - Engranajes. University of Lleida (UDL)

¹³ Source.

<http://www.anaheimautomation.com/manuals/forms/ac-motorguide.php#sthash.fKgjzly1.dpbs>

Second part. Research work

5. Energy-generator swing



The main idea of this project arises from the concern of the damage we have already caused to the environment by over usage of the main energy sources. The prototype presented in the following document is based on taking advantage of the mechanical energy that is provided by children's movement for electricity production and how it can be stored for later use (such as in parks overnight, schools, nearby residential, etc.) or send directly to the grid if it can be sourced.

5.1. Introduction to the energy-generator swing

The main idea to build this energy-generator swing is that children have the opportunity to have a playful installation in the one hand and on the other hand interact with the production process of electricity. It is intended to build a driveshaft with a one-gear assembly coupled with an alternator on the swing to derive the energy of the children.

Thanks to the project built by Moradavaga¹⁴, “for the Pop up Culture competition”, promoted by Guimaraes, Portugal in November of 2012 the first swing was introduced. This project has served as a support and motivation. The function is quite simple. Basically, there is a bicycle chain attached to the swing with a counterweight in the back to spin the bicycle wheel. At the wheel a common bicycle dynamo is fixed to produce electricity for a hidden light bulb underneath the floor. (See appendix 1. Low-tech system. Project SWING / Moradavaga.)

This study tries to find out an efficient mechanism because usually young people try to touch all the visible things and at the same time destroy it. Due to the complex mechanism in the swing such as gears, generators, etc. it is perhaps better to hide these so children will not get hurt and at the same time they can play without their families to worry.

The goal of this project would be to invent a small-scale alternative to replace the traditional energy generation by fossil fuel by using structures in a playground (like elementary school or Childcare Center). There is hope that this initiative could create educational playgrounds where children feel involved in the production of energy while playing, feeling good and get fit at the same time. When the public gets more involved in the process of clean energy, they will contribute more to ensure the wellbeing of our planet.

The driveshaft of the electrical generator swing is composed of one cogwheel, two roller bearings, two drawn cup roller clutches, and one generator. In addition, the Roller bearings shall be mounted on the driveshaft at the point where the two bars supporting the swing meet the driveshaft. Moreover, the two roller clutches are situated at the points where the strings of the swing are coupled to the driveshaft. The cogwheel is situated in one of the extremes of the driveshaft, this cogwheel is connected to a smaller gear which is driving the alternator.

¹⁴ Source. <http://moradavaga.com/SWING>

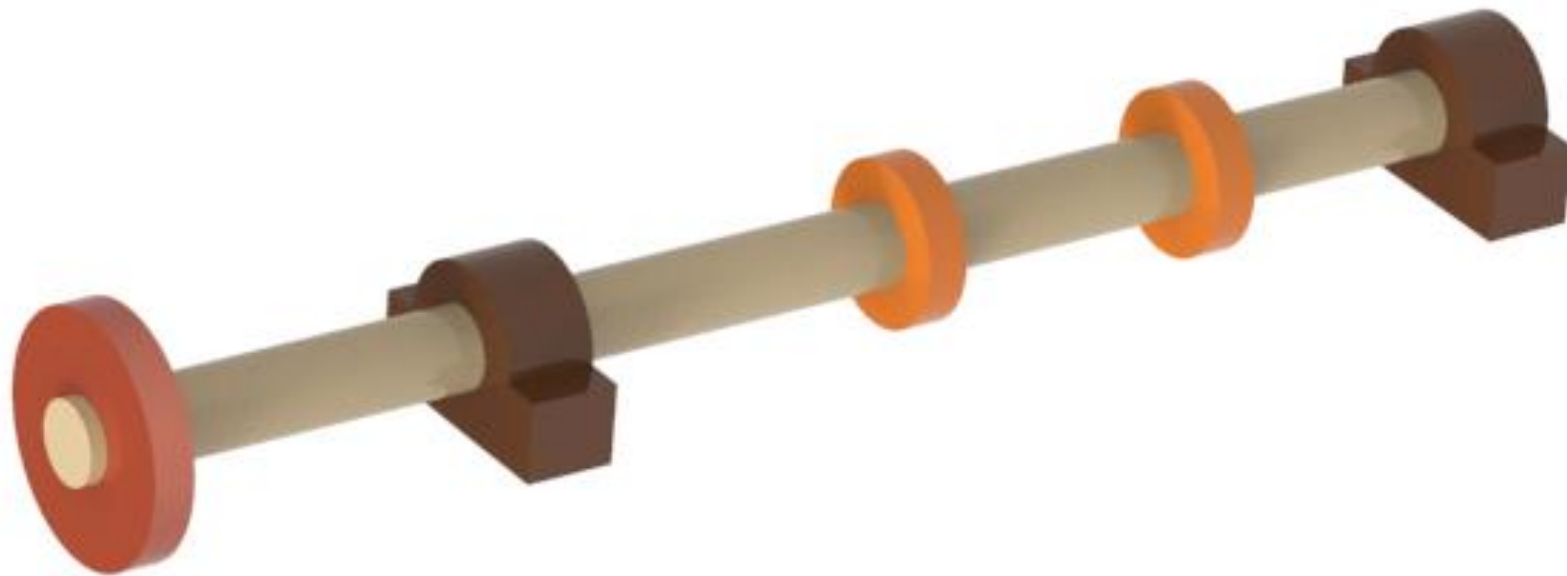

Figure 11. Components of the driveshaft

5.2. Theoretical Bases

5.2.1. Conservative forces

Conservative forces, if applied to a particle follow a closed path, with the same start and end point, no work done. As a result, the work done by a conservative force between certain start and end points is independent of the route followed by the point of application of force.

Note: For the study of mechanisms two types of conservative forces must be considered: the weight due to the gravitational attraction and the power made by a spring.

Given this property that the work done by conservative forces is independent of the path followed and only depends on the starting and ending points of the route: you can define the potential energy of a system, as energy that is in a certain position within a field of conservative forces. Then, the increase of potential energy is the absolute value of the work done by a conservative force to move the system from one position to another.

$$\Delta E_p = -(W_c)_{1 \rightarrow 2} = - \int_1^2 \vec{F}_c \cdot \vec{dr}$$

Said in another way, the difference in potential energy is consumed to perform conservative force, a work between the start and end positions.

Replacing the expression of energy theorem and separating the not conservative work and conservative:

$$W_{1 \rightarrow 2} = E_{k2} - E_{k1}$$

$$(W_{nc})_{1 \rightarrow 2} + (W_c)_{1 \rightarrow 2} = \Delta E_k$$

$$(W_{nc})_{1 \rightarrow 2} = \Delta E_k - (W_c)_{1 \rightarrow 2} = \Delta E_k + \Delta E_p$$

Mechanical energy is defined as the sum of kinetic energy and potential energy. Then:

$$(W_{nc})_{1 \rightarrow 2} = \Delta E_m$$

A particular case, which frequently occurs in is when you have a system in which the work done by non-conservative forces is zero. Then the mechanical energy is maintained and in any case that can happen is that there is an exchange between kinetic and potential energies.

$$W_{nc} = 0 \rightarrow E_m = E_k + E_p = \text{constant}$$

(Principle of conservation of mechanical energy: If the work done on a system that the forces not conservative is zero, then the mechanical energy system remains constant.)

5.2.2. Potential energy due to the gravitational field

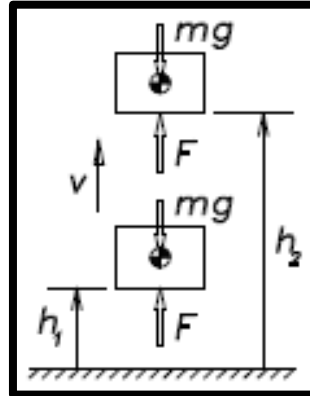

Figure 12. Potential energy due to gravity¹⁵

It has a solid mass m , which acts on the Earth's gravitational field, if you want to analyze how the solid moves from a first position (a height h_1 with respect to the ground) to a second position (at a height h_2).

Assuming that the intensity of the gravitational field is constant ($g = 9.81 \text{ m} / \text{s}^2$) hypothesis that can be considered true in virtually all studies of mechanisms, the work done by the force weight, conservative, will be:

$$W_{1 \rightarrow 2} = - \int_1^2 m \cdot g \cdot dh = -m \cdot g \cdot (h_2 - h_1)$$

Applying the definition of potential energy, we come to the following expression which shows that the potential energy due to the gravitational field depends only on the height at which places this solid.

$$Ep_2 - Ep_1 = m \cdot g \cdot (h_2 - h_1)$$

¹⁵ Source. Teoría de mecanismos, University of Lleida (Udl)

5.3. Design of the electrical generator swing

The design of the electrical generator swing, has been divided into three steps. In the **first step**, the energy balance is calculated from the initial position of the swing (0°), until the supposed maximum position (70°), which can be reached, to find the maximum velocity that the swing can have. Afterwards, the point with the force of the string that the system can support and also the maximum torque on the shaft that the children can do is determined.

In the **second step**, the reactions on the first cogwheel are calculated on the roller bearings. Finally, in the **third step**, the driveshaft is studied and calculated, including the fatigue resistance of it. Finally, the driveshaft is recalculated to adapt all the components.

5.4. First step: Energy balance

To start with, the energetic balance between the highest and the lowest positions is measured. This is used to calculate the maximum velocity, which takes place at the minimum height. At this point the force of the string is the maximum force that the string has to support (T).

Table 3. Assumptions for the energy balance

Assumptions	Value	Units of measures
L (length of the string)	2000	mm
m (mass)	70	kg
Θ (maximum angle of the swing)	70	$^\circ$
Safety factor	1,2	-

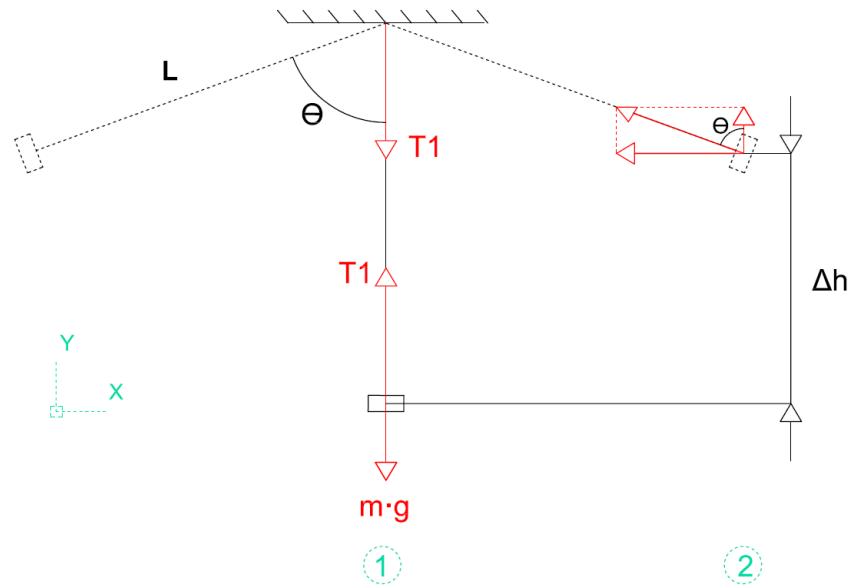

Figure 13. Diagram of the energy balance from 1 to 2

$$\Delta h = L - L \cdot \cos\theta = 2 - 2 \cdot \cos 70^\circ = 1,316 \text{ m}$$

Energy balance 1 – 2

$$E_k = E_p \text{ (Equation 4.3.1)}$$

$$\frac{1}{2} \cdot m \cdot v^2 = m \cdot g \cdot h$$

$$v = \sqrt{g \cdot h \cdot 2}$$

$$v = 5,079 \text{ m/s}$$

$$v = \omega \cdot L$$

$$\omega = 2,53 \frac{\text{rad}}{\text{s}}$$

Calculation of the maximum force that the string will have to support (T_1).

$$\sum F_y = m \cdot a \text{ (Equation 4.3.2) (Second law of motion)}$$

$$T_1 - m \cdot g = m \cdot \frac{v^2}{L} \rightarrow T_1 = m \cdot g + \frac{m \cdot v^2}{L}$$

$$T_1 = 1.589 \text{ N}$$

Now, the safety factor is applying in order to avoid any problems in case of misuse of the swing.

$$T_1 = 1.906,642 \text{ N} = 1.91 \text{ kN}$$

Moreover, the maximum torque is calculated to know the torque that will be applied to the cogwheel. The radius and the angle is assumed, also it is needed to say that this radius belongs the ring where the string is attached.

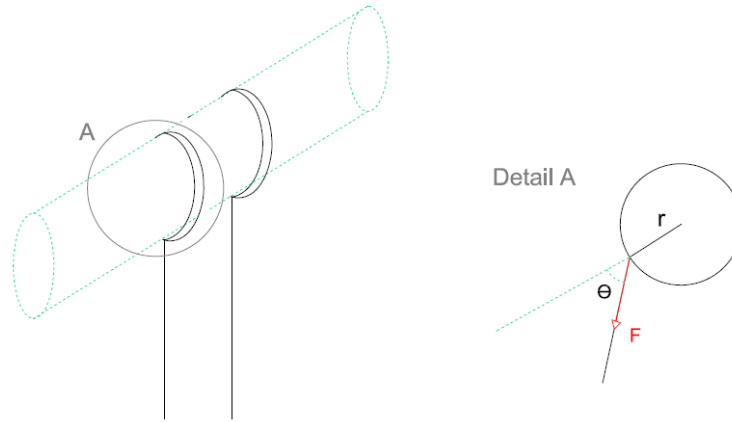

Figure 14. Diagram to calculate the torque.

$$F = T_1$$

$$M = F \cdot r \cdot \sin \theta = T_1 \cdot r \cdot \sin \theta \quad (\text{Equation 4.3.3})$$

$$r = 55 \text{ mm} ; \theta = 30^\circ$$

$$M = 52,433 \text{ N} \cdot \text{m} \quad (\text{Maximum torque})$$

Moreover, this torque will have to be borne by the roller clutches and the cogwheel, when it is proceed to the choice from them. It is needed to add the torque which each roller clutches will receive (it will be the half of this torque).

5.5. Second step: Reactions on the cogwheel

From the torque calculate before it is possible to determine the maximum reactions the first cogwheel will have to support. These reactions need to be considered in the calculations of the driveshaft.

Table 4. Assumptions for the calculation of the reaction on the cogwheel

Assumptions	Value	Units of measure
R (radius of the cogwheel)	400	mm
α (Pressure angle)	20	°
M_{\max} (Maximum torque)	52,433	N·m
Gear ratio (i)	1,3	-

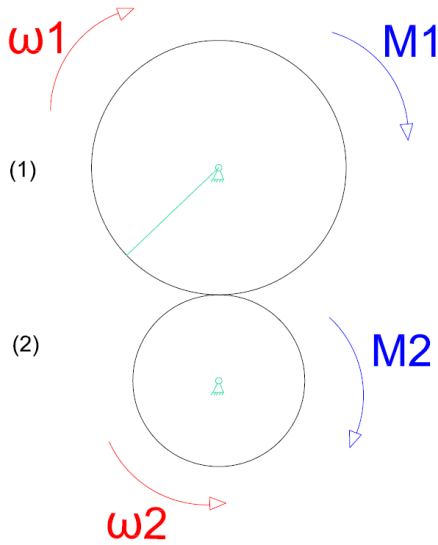

Figure 15. Cogwheel assembly

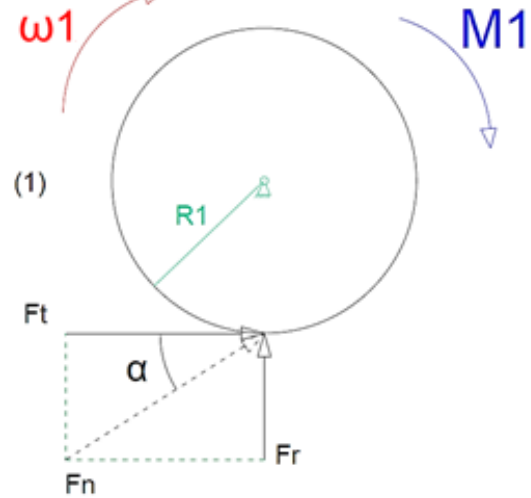

Figure 16. Reactions on the cogwheel of the driveshaft

$$M_{max} = F_t \cdot R_1 \quad (\text{Equation 4.3.4})$$

$$F_t = 131,082 \text{ N}$$

$$F_r = F_t \cdot \tan \alpha \quad (\text{Equation 4.3.5})$$

$$F_r = 47,71 \text{ N}$$

$$i = \frac{\omega_2}{\omega_1}$$

The angular velocity affecting on the first cogwheel is 2, 53 rad/s, calculated previously.

$$\text{So, } i = \frac{\omega_2}{\omega_1} \Rightarrow \omega_2 = i \cdot \omega_1$$

$$\omega_2 = 3,29 \frac{\text{rad}}{\text{s}} \text{ In the opposite direction to the } \omega_1$$

Finally, to know the radius of this second cogwheel:

$$i = \frac{R_1}{R_2} \Rightarrow R_2 = 0,308 \text{ m} = 308 \text{ mm}$$

5.6. Third step: Design of the driveshaft

The design of the driveshaft is studied from the reaction on the roller bearings. Then, the bending moment, the torque (moment), and the axial strain in the driveshaft are calculated. Finally, the fatigue resistance is calculated of the driveshaft. In order to calculate the strain on the driveshaft, it has been considered radial loads on the two roller bearings and roller clutches.

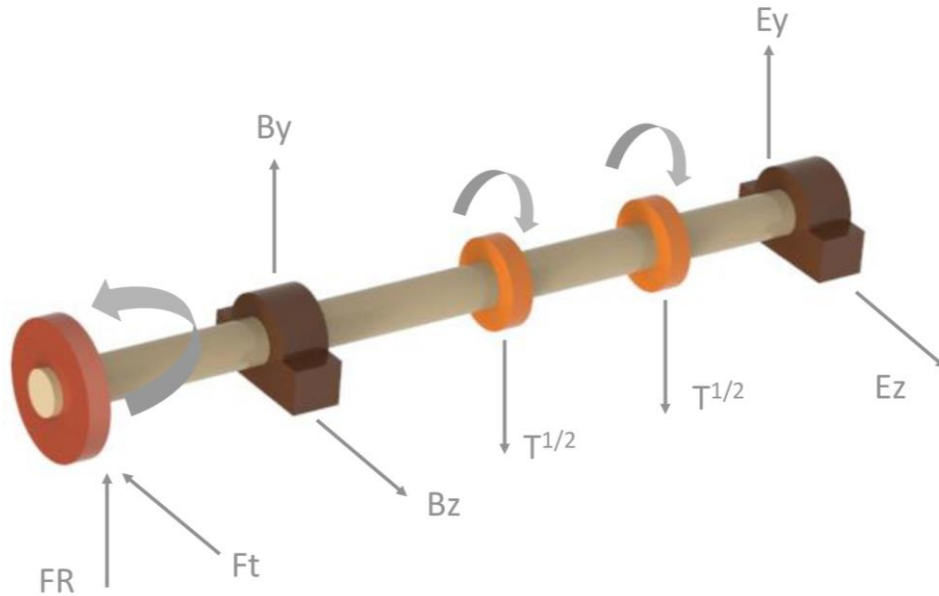

Figure 17. Reaction on the driveshaft

5.6.1. Calculation of the roller bearings

Two cylindrical roller bearings, one cogwheel, and two roller clutches are situated on the driveshaft. It is possible to calculate the reactions on the roller bearings with the forces applied in the driveshaft from these elements. It also has to be considered that there are no axial forces on the system. In addition, it is to be assumed that the reactions on the roller clutches in the z-axis have been underestimated. It has to be also taken into consideration that the weight of the cogwheel in this specific case, has been ignored.

Table 5. Necessary data before the calculation of the reactions on the roller bearings

Data	Value	Units of measure
Ft	131,082	N
$\frac{T1}{2}$	953,321	N · m
Fr	47,71	N · m

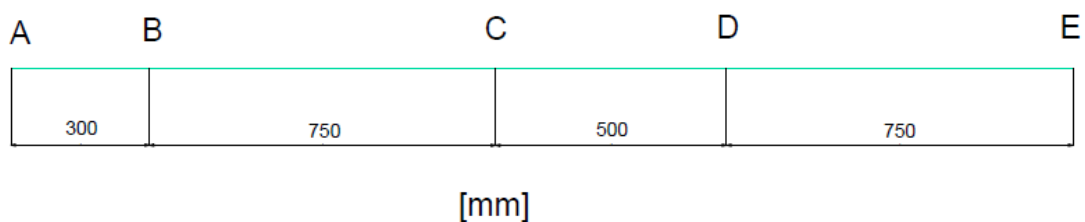

Figure 18. Diagram with the distance between the elements of the driveshaft.

X-Y Cartesian coordinate system

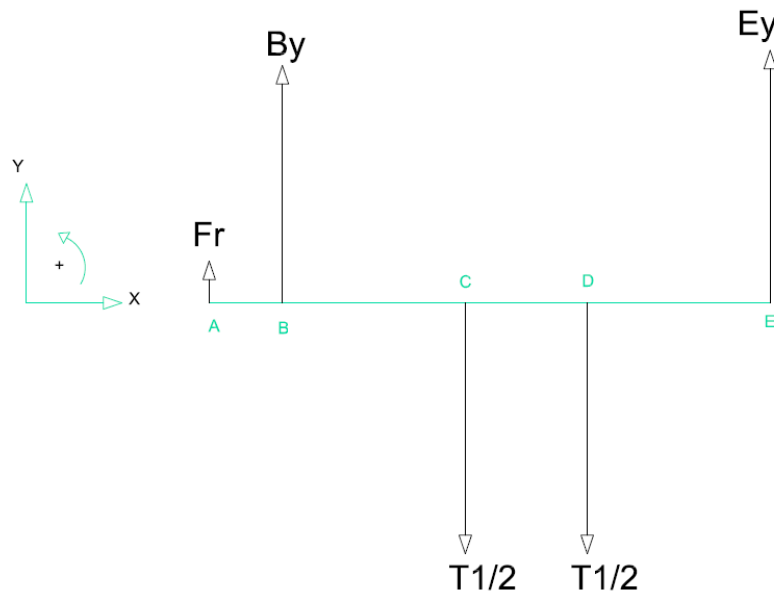

Figure 19. Diagram of the X-Y Cartesian coordinate system of the driveshaft-

$$\left(\sum M_z\right)_B = 0 \text{ (Equation 4.3.6)}$$

$$\left(\sum M_z\right)_B = -Fr \cdot 0,3 - \frac{T1}{2} \cdot 0,75 - \frac{T1}{2} \cdot 1,25 + Ey \cdot 2 = 0$$

$$Ey = 960,478 \text{ N}$$

$$\sum F_y = 0 \text{ (Equation 4.3.7)}$$

$$\sum F_y = Fr + By - T1 + Ey = 0$$

$$By = 898,454 \text{ N}$$

X-Z Cartesian coordinate system

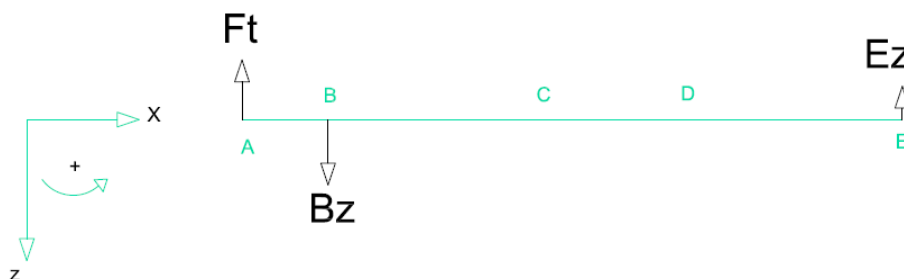

Figure 20. Diagram of the X-Z Cartesian coordinate system of the driveshaft

$$\left(\sum M_y\right)_E = 0 \text{ (Equation 4.3.8)}$$

$$\left(\sum M_y\right)_E = -Ft \cdot 2,3 + Bz \cdot 2 = 0$$

$$Bz = 150,744 \text{ N}$$

$$\sum F_z = 0 \text{ (Equation 4.3.9)}$$

$$\sum F_z = -Ft + Bz - Ez = 0$$

$$Ez = 19,622 \text{ N}$$

Therefore, the radial loads on the roller bearings are:

$$Br = \sqrt{By^2 + Bz^2} \text{ (Equation 4.3.10)}$$

$$Er = \sqrt{Ey^2 + Ez^2} \text{ (Equation 4.3.11)}$$

$$Cr = \sqrt{Cy^2 + Cz^2} \text{ (Equation 4.3.12)}$$

$$Dr = \sqrt{Dy^2 + Dz^2} \text{ (Equation 4.3.13)}$$

$$Cr = \sqrt{\left(\frac{T1}{2}\right)^2} = \frac{T1}{2}$$

$$Dr = \sqrt{\left(\frac{T1}{2}\right)^2} = \frac{T1}{2}$$

Table 6. Values of the radial loads

Radial loads	Value	Unit of measures
Roller bearing point B: Br	911,012	N
Roller bearing point E: Er	960,679	N
Roller clutches point C: Cr	953,321	N
Roller clutches point D: Dr	953,321	N

Selection of the roller bearings

Both roller bearings have radial loads; therefore both will have the same type of roller bearing.

Dimensioning of roller bearings for dynamic application from the catalogue¹⁶:

1. Select the type of roller bearing depending on the type of load.
2. Suppose a lifetime (L).
3. Calculate the equivalent dynamic load (P).
4. Analyze alternatives of roller bearing with the required load capacity (C).
5. Choose the diameter from C.

Select roller bearing “B” and “E”: Cylindrical roller bearing (only support radial loads).



Figure 21. Different types of cylindrical roller bearing.

		Características:			
		Carga radial	Carga axial en ambas direcciones	Compensación longitudinal en el rodamiento	Compensación longitudinal con ajuste deslizante
<p>● Aptitud muy buena ◐ limitada</p> <p>◑ buena ○ no adecuada / no aplicable</p> <p>◒ normal / aceptable</p>					
Tipo de rodamiento					
Rodamientos rígidos de bolas		◑	◑	○	◑
Rodamientos de bolas de contacto angular		◑	◑	○	◑ ^a
Rodamientos de bolas de contacto angular, de doble hilera		◑	◑	○	◑
Rodamientos para husillos		◑	◑	○	◑ ^a
Rodamientos con cuatro caminos de rodadura		◑	◑	○	○
Rodamientos oscilantes de bolas		◑	◑	○	◑
Rodamientos de rodillos cilíndricos NU, N		●	○	●	○

Figure 22. Characteristics of roller bearings

¹⁶ <http://www.baleromex.com/catalogos/C-FAG.pdf>

The lifetime for both roller bearings that is assumed is:

$$\left(15 \text{ anys} \cdot \frac{288 \text{ dies}}{1 \text{ any}} \cdot \frac{4 \text{ h}}{1 \text{ dia}} \cdot \frac{60 \text{ min}}{1 \text{ h}} \cdot \frac{20 \text{ rev}}{1 \text{ min}} = 20,7 \cdot 10^6 \text{ rev} \right) \text{ (Equation 4.3.14)}$$

Roller bearings “B” and “E”: Cylindrical roller bearings

Following the steps of the catalogue “Rodamientos FAG” the previous inner diameter is:

$$\varnothing_B = \varnothing_E = 15 \text{ mm}$$

To see how it has been calculated the diameters above see Appendix 1. (1.2 Calculation of the dimensioning on request dynamic of roller bearings.)

Selection of the roller clutches

Both roller clutches have radial loads, and equal torques they need to support. Hence, both will have the same type of roller clutches.

Dimensioning of roller clutches for dynamic application from the catalogue¹⁷ NTN Americas.

Select roller clutches “C” and “D”: Cylindrical roller bearings (only support radial loads).

1. Classification and Characteristics of Rolling Bearings

1.1 Rolling bearing construction

Most rolling bearings consist of rings with raceway (inner ring and outer ring), rolling elements (either balls or rollers) and cage. The cage separates the rolling elements at regular intervals, holds them in place within the inner and outer raceways, and allows them to rotate freely.

Raceway (inner ring and outer ring) or raceway washer ¹⁾

The surface on which rolling elements roll is called the "raceway surface". The load placed on the bearing is supported by this contact surface.

Generally the inner ring fits on the axle or shaft and the outer ring on the housing.

Note 1: The raceway of thrust bearing is called "raceway washer," the inner ring is called the "shaft raceway washer" and the outer ring is called the "housing raceway washer."

Rolling elements

Rolling elements classify in two types: balls and rollers. Rollers come in four types: cylindrical, needle, tapered, and spherical.

Balls geometrically contact with the raceway surfaces of the inner and outer rings at "points", while the contact surface of rollers is a "line" contact.

Theoretically, rolling bearings are so constructed as to allow the rolling elements to rotate orbitally while also rotating on their own axes at the same time.

Cages

Cages function to maintain rolling elements at uniform

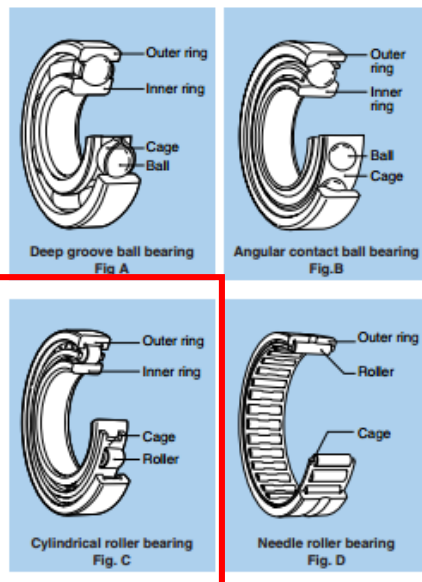

Figure 23. Characteristics of roller bearings

¹⁷http://www.ntnamericas.com/en/website/documents/brochuresandliterature/catalogs/ntn_2202-ixe.pdf

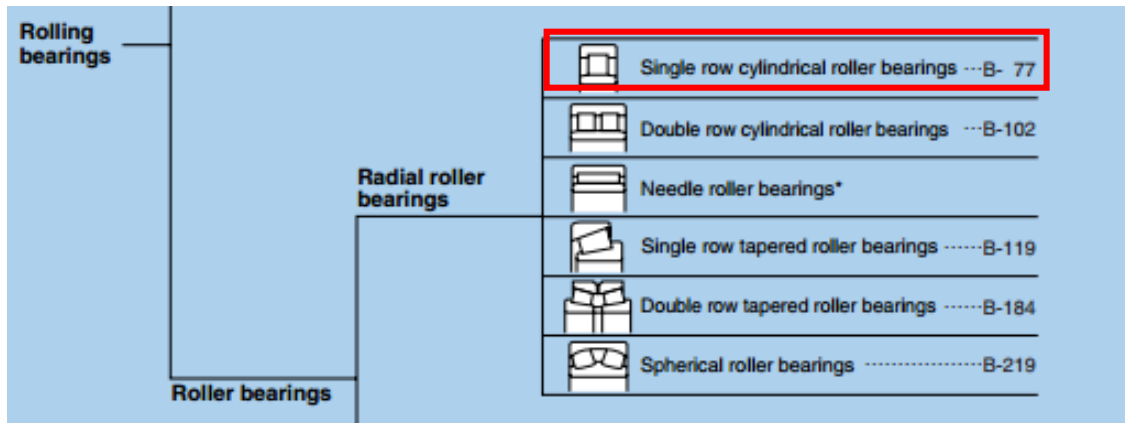

Figure 24. Classification of roller bearings

Roller clutches “C” and “D”: Cylindrical roller bearings

Following the steps of the catalogue “Ball and Roller Bearing - NTN” with the radial load, the previous inner diameter is:

$$\varnothing_C = \varnothing_D = 20 \text{ mm}$$

To see how it has been calculated the diameters above see Appendix 1. (1.3 Calculation of the dimensioning on request dynamic of roller clutches.)

5.6.2. Study and calculation of the driveshaft

Bending moment

Table 7. Data to calculate the bending moments in the both Cartesian coordinate systems

Loads	Value	Unit of measures
Ft	131,082	N
By	898,454	N
Cy	953,321	N
Dy	953,321	N
Ey	960,478	N
Fr	47,71	N
Bz	150,744	N
Ez	19,662	N

Sign criteria to follow:

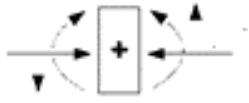

$$\sum M = 0 \text{ (Equation 4.3.15)}$$

Bending moment Mz (X-Y Cartesian coordinate system)

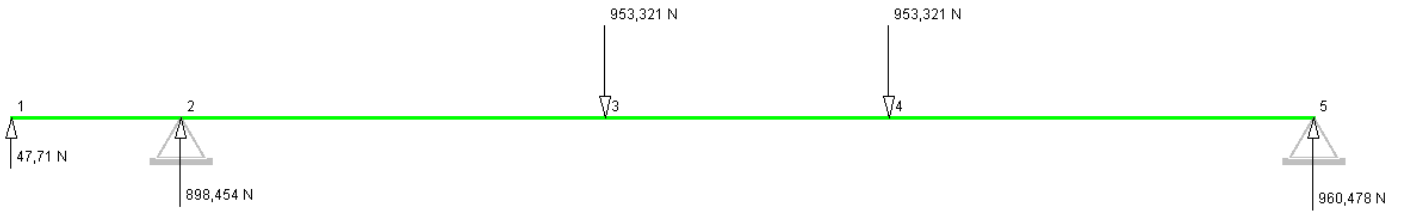

Figure 25. Load diagram on the driveshaft (Cartesian coordinate system Y-Z)

Stretch 1-2: $0 < x < 300 \text{ mm}$

$$M(x) = 47,71(x) \cdot 10^{-3}$$

Stretch 2-3: $300 < x < 1050 \text{ mm}$

$$M(x) = 47,71(x) \cdot 10^{-3} + 898,454 \cdot (x - 300) \cdot 10^{-3}$$

Stretch 3-4: $1050 < x < 1550 \text{ mm}$

$$M(x) = 960,478 \cdot (2300 - x) \cdot 10^{-3} - 953,321 \cdot (2300 - x - 750) \cdot 10^{-3}$$

Stretch 4-5: $1550 < x < 2300 \text{ mm}$

$$M(x) = 960,478 \cdot (2300 - x) \cdot 10^{-3}$$

Table 8. Results of the bending moment X-Y

Bending moment 1	0 N·m
Bending moment 2	14,313 N·m
Bending moment 3	723,937 N·m
Bending moment 4	720,359 N·m
Bending moment 5	0 N·m

The previews bending moments has been checked with the “Barras software” developed by the professor Javier Bradineras from the University of Lleida.

Table 9. Results using the software "Barras"

Esforços						
Barra	Axil T (N)	Esforços tallants T (N)	Moments flectors T (...)	Axil T (N)	Esforços tallants T (N)	Moments flectors T (...)
[1-2]	0	-47,71	0	0	-47,71	14.313
[2-3]	0	-946,165	14.313	0	-946,165	723.936,375
[3-4]	0	7,157	723.936,375	0	7,157	720.358,125
[4-5]	0	960,478	720.358,125	0	960,478	0

Representation of the bending moment in the Cartesian coordinate system Y-X.

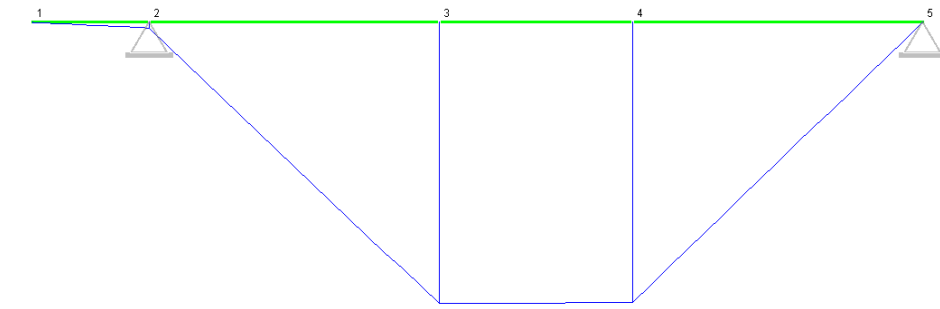

Figure 26. Diagram of the bending moment M_z .

Bending moment M_y (X-Z Cartesian coordinate system)

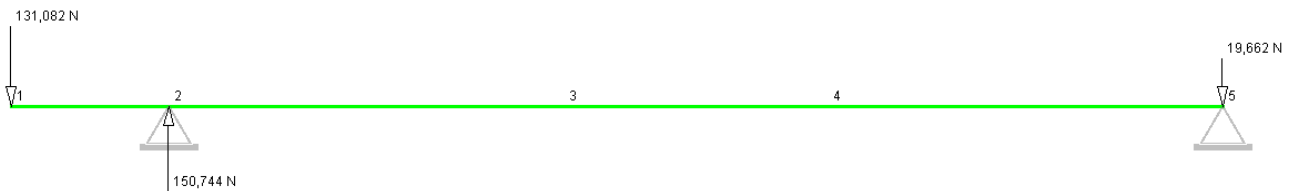

Figure 27. Load diagram on the driveshaft (Cartesian coordinate system X-Z)

Stretch 1-2: $0 < x < 300 \text{ mm}$

$$M(x) = -131,082(x) \cdot 10^{-3}$$

Stretch 2-3: $300 < x < 1050 \text{ mm}$

$$M(x) = -19,662 \cdot (2300 - x) \cdot 10^{-3}$$

Stretch 3-4: $1050 < x < 1550 \text{ mm}$

$$M(x) = -19,662 \cdot (2300 - x) \cdot 10^{-3}$$

Stretch 4-5: $1550 < x < 2300 \text{ mm}$

$$M(x) = -19,662 \cdot (2300 - x) \cdot 10^{-3}$$

Table 10. Results of the bending moment X-Z

Bending moment 1	0 N·m
Bending moment 2	-39,325 N·m
Bending moment 3	-24,578 N·m
Bending moment 4	-14,747 N·m
Bending moment 5	0 N·m

The previews of the bending moments have been checked with the “Barras software” developed by professor Javier Bradineras from the University of Lleida.

Table 11. Results using the software "Barras"

Esforços						
Barra	Axil T (N)	Esforços tallants T (N)	Moments flectors T (...)	Axil T (N)	Esforços tallants T (N)	Moments flectors T (...)
[1-2]	0	131,082	0	0	131,082	-39.324,6
[2-3]	0	-19,662	-39.324,6	0	-19,662	-24.577,875
[3-4]	0	-19,662	-24.577,875	0	-19,662	-14.746,725
[4-5]	0	-19,662	-14.746,725	0	-19,662	0

Representation of the bending moment in the Cartesian coordinate system Z-X



Figure 28. Diagram of the bending moment M_y .

Torque moment

All torque that is produced by the swing on the roller clutches is transmitted to the cogwheel.

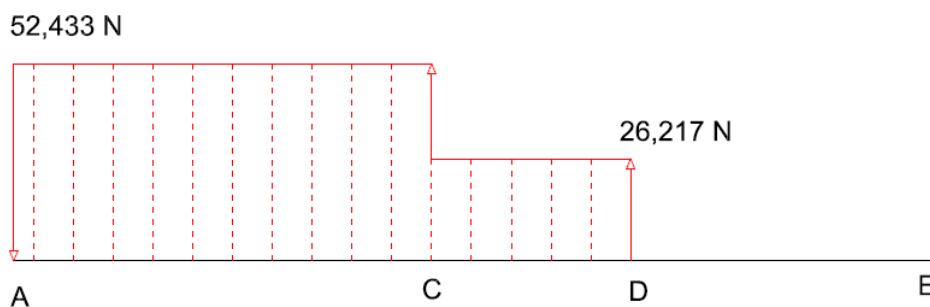

Figure 29. Diagram of the torque moment M_t .

5.6.3. Calculation of the fatigue resistance on the driveshaft

Based on the DECKER, K.H. “Elementos de maquinas” bibliography, the diameter of the driveshaft is calculated by the worst-case scenario from bending moments and torque moments, obtained previously.

It is expected, that point C (roller clutches) will be in the worst section. However, it is also calculated at the point B (cylindrical roller bearing).

To ensure that the diameter of the tree can withstand the strains mentioned above, it will have to achieve: $\sigma_{adm} \geq \sigma_v$, where $\sigma_{adm} = \frac{\sigma_G}{C_S}$ and σ_v is the equivalent tensile stress.

The fatigue resistance in the considered section is: $\sigma_G = \frac{\sigma_W \cdot b_0}{\beta_{kb} \cdot (1-R)}$, where σ_W is the traction and compressive fatigue resistance, that considers a steel with the traction resistance, $\sigma_B = 450 \frac{N}{mm^2} \rightarrow \sigma_W = 210 \frac{N}{m}$.

The other values which are needed to calculate σ_G are found it in the appendix 1. (1.4. Dimensioning the diameter of the driveshaft).

The equivalent tensile stress is calculated as: $\sigma_v = \sqrt{\sigma_0^2 + (3\alpha_0^2)\tau_t^2}$, where σ_0 is the value composed of the stress (produced by the axil and bending stresses, in this case there are no axial stresses in the system), that are in the studied section.

α_0 is the fatigue factor, in this case the torque and bending moments diagram are considered pulsating, by the DECKER, K.H. “Elementos de maquinas” bibliography it is obtained that $\alpha_0 = 1$; τ_t is the torque stress.

The composite stress is calculated as, $\sigma_0 = \frac{M_b}{W_b} + \frac{N}{\frac{\pi d^2}{4}}$ where M_b is the bending moment (vector sum of bending moments obtained in each Cartesian coordinate system), in the studied section, W_b is the moment resistance, that considered a smooth shaft, $W_b \approx 0,1 \cdot d^3$. N is the value of the axial stress that in this design there is no axial stress.

The torque stress in the studied section is, $\tau_t = \frac{M_t}{W_t}$ where M_t and W_t are the torque moment and the resistant moment, that considered a smooth shaft, $W_t = 0,2 \cdot d^3$.

Study to point B (cylindrical roller bearing):

For a diameter $d = 20 \text{ mm}$, the results of the stresses are:

$$\sigma_G = 227,74 \text{ N/mm}^2, \text{ and considering a correction factor of } C_S = 1,3, \sigma_{adm} = \frac{227,74}{1,3} = 175,19 \text{ N/mm}^2. \sigma_v = 77,19 \text{ N/mm}^2.$$

As $175,19 \text{ N/mm}^2 \geq 77,19 \text{ N/mm}^2$, this diameter can withstand the loads in point B.

For more information about the previous results of the study in point B, see Appendix 1. (1.4 – 1.5. Dimensioning the diameter of the driveshaft at point B).

Study to point C (roller clutches):

For a diameter $d = 40 \text{ mm}$, the results of the stresses are:

$$\sigma_G = 225,92 \text{ N/mm}^2 \text{ , and considering a correction factor of } C_s = 1,3, \sigma_{adm} = \frac{225,92}{1,3} = 173,78 \text{ N/mm}^2 \text{ . } \sigma_v = 113,4 \text{ N/mm}^2 \text{ .}$$

As $173,78 \text{ N/mm}^2 \geq 113,4 \text{ N/mm}^2$, this diameter can withstand the loads in point C without being “too” oversized.

For more information about the previous results of the study in point C, see Appendix 1. (1.6 – 1.7. Dimensioning the diameter of the driveshaft at point C).

5.7. Remodeling and selection of the components

To determinate the final dimensions of the driveshaft, the elements have to be decided to permit affix union on the cogwheel and roller bearings. Furthermore, it has to be kept in mind that the assembly of these elements has to be possible. The dimensions found in the first part are:

Inner diameter cylindrical roller bearing = 15mm

Inner diameter drawn cup roller clutches = 20mm

Outside diameter shaft = 50mm

Inner diameter shaft = 40mm

In order to affix all the elements on the drive shaft, the outside diameter of the driveshaft is considered, based on the study of point C (the worst section), so the two roller clutches need a large inner diameter to attach on the shaft. To be noted, with this alteration the roller clutches will be able to support more loads than the loads calculated.

Moreover, with the roller bearings at the same level the new inner diameter will be 50mm, since the inner diameter for the shaft has been calculated with 50 mm.

The finals dimensions of the driveshaft will be:

Inner diameter cylindrical roller bearing = 40mm

Inner diameter drawn cup roller clutches = 50mm

Outside diameter shaft = 50mm

Inner diameter shaft = 40mm

Inner diameter cogwheel = 25mm

See appendix 1 (1.8) to know how these elements have been selected.

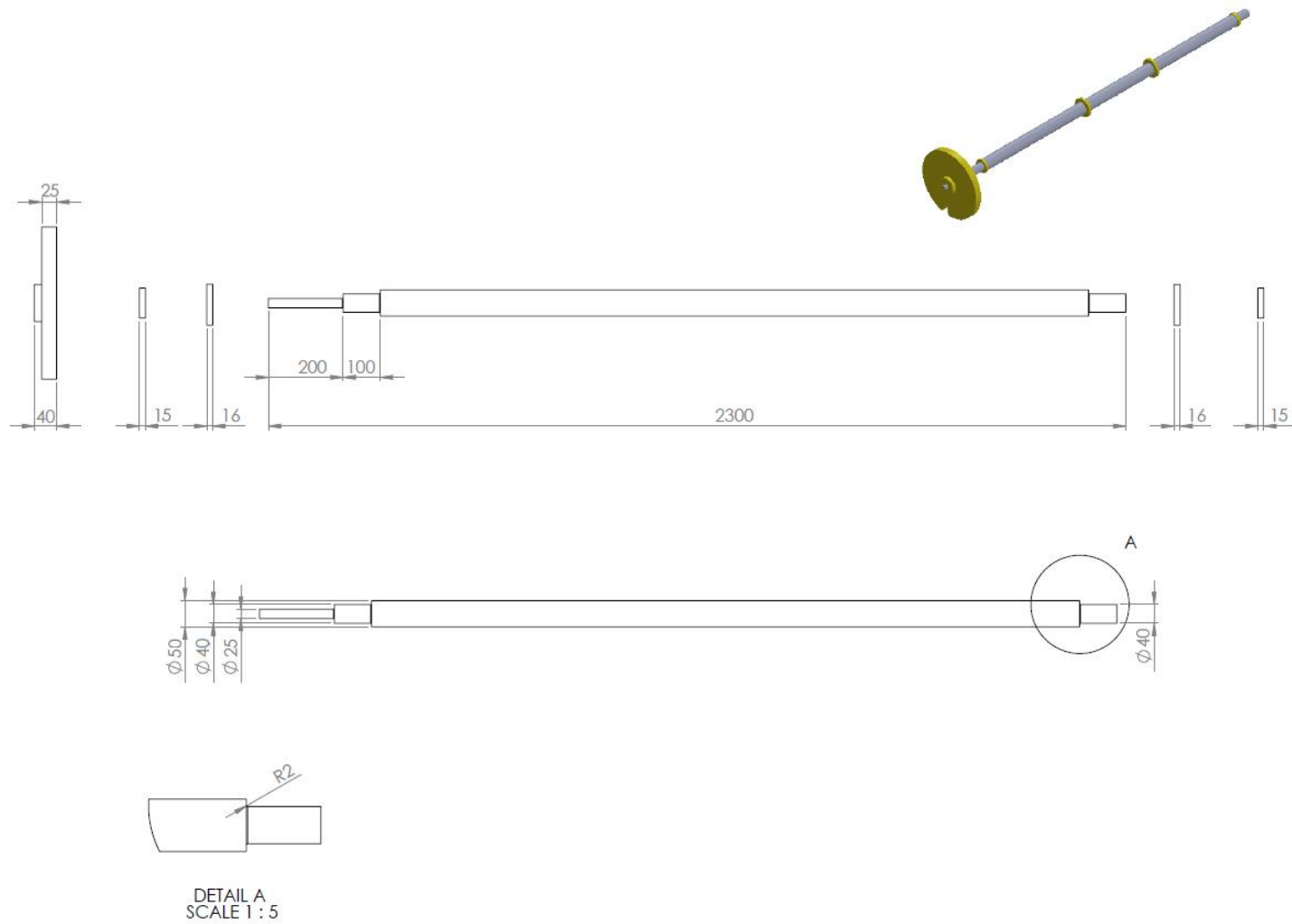

Figure 30. Drawings of the principals views of the driveshaft and roller bearings

5.8. Estimation of the power output

Once the design of the driveshaft has been calculated, it is possible to estimate the output power. The second cogwheel is attached to an alternator, which converts the rotational energy into electricity. For this calculation the efficiency is assumed at 92%. The efficiency of the gears normally ranges between 90% and 96%.

Table 12. Data assumption

Data	Value	Unit of measure
M_1	52,433	N · m
w_1	2,53	rad/s
w_2	3,29	rad/s
η (efficiency assume)	0,92-0,96	-

$$P_{in} = M_1 \cdot w_1 \text{ (Equation 4.5.1)}$$

$$P_{out} = M_2 \cdot w_2 \text{ (Equation 4.5.2)}$$

$$\eta = \frac{P_{out}}{P_{in}} \text{ (Equation 4.5.3)}$$

$$P_{out} = P_{in} \cdot \eta = (52,433 \cdot 2,53) \cdot 0,92 = 122,043 \text{ W}$$

$$P_{out} = 0,122 \text{ kW}$$

Finally, it is observed that if the swing were used continuously during one hour at the maximum rate, the energy generated would be 0,122 kWh.

To understand this value: a common light-bulb used in playgrounds would have around 100W.¹⁸ If this bulb remains switch on during 1 hour it consumes:

$$\text{(Common light-bulb) } 100\text{W} = 0,1\text{kW} \rightarrow 0,1\text{kW} \cdot 1 \text{ hour} = 0,1\text{kWh}$$

$$\text{(LED): } 10\text{W} = 0,01\text{kW} \rightarrow 0,01\text{kW} \cdot 10 \text{ hours} = 0,1\text{kWh}$$

Therefore, the power generated by the proposed design is enough to have one LED switched on for 10 hours or 10 LED's during 1 hour, or one common light-bulb switched on for 1 hour.

¹⁸ Source. <http://www.iluminet.com/luminarios-para-alumbrado-publico-de-vialidades-con-lamparas-de-induccion-electromagnetica/>

5.9. Conclusions

In the completion of this work many concepts have been acquired and consolidated, such as: designing transmission gears and the design of a driveshaft and roller bearings selection according to the type of forces they are subjected to, especially roller clutches.

The design part of the driveshaft has needed much attention due to the high amounts of calculations to find out the forces, which the driveshaft is subjected to, plus it was needed to work in three dimensions and work with calculations unlikely to a bachelor level. It would have been better go more in depth on the study of this element; however due to lack of time and knowledge acquired to calculate the dimensions of pins for example it has not been possible.

From the negative point of view, it can be say that if is probably that the kids need to do more force than with one conventional swing, because of the alternator is required to rotate at one speed to produce electricity. Also this can produce that it would be not very fun to play with it if the kids cannot go very fast, but on the other hand, it could teach the children to learn the difficulty of producing electrical energy in a clean way, without non-renewable sources.

In conclusion, the design outcome is positive being that it is possible to produce electricity in a small scale. It was possible to make a re-design of a swing. Furthermore, it was possible to use prior gained knowledge from the past study years to select and design a piece that is useful for everyday life.

6. Merry-Go-Round Mechanism

How to get electricity in a clean way using our own energy? This project tries to pair providing energy and at the same time supports children to play, have fun, do exercise and learn how to produce energy in a non-polluting way. Thanks to generators in children play-parks this might be possible. This project intends to redesign the well-known merry-go-round. Using human power to produce mechanical energy and transform it into electrical one.

6.1. Introduction to Merry-Go-Round

As known, the field of the renewable energy is rapidly growing. In the last 10 years this field had the highest increased and thus, investments rose. Moreover, it is expected that in 2030 the government investment around the world will be 2 or 3 times more than is now. This increase can be explain as the nowadays way of energy production is not sustainable because of the high use of non-renewable energy such as fossils. The need of electricity will never end; therefore finding new ways to source is crucial.

In the world, the most common human power generator is the bicycle or the hand cranked generator. The way they work is attaching a bike tire to convert the rotation into electricity or using a hand-cranked apparatus. The last one is used to power small devices such as a light or a mobile charger. We have to bear in mind that this type of technology has been around for decades, now we are only improving it but without changing the basic way of function. One example of this improvement is the exercise machine to produce electricity.

Thanks of this machine; people get fit while producing no pollutant electricity. So, what about the use of this energy production in parks where children play? The main idea is using a marry-go-round to produce electricity to illuminate parks or to charge any electric device with an USB port.

The merry-go-round generator will operate by turning the human mechanical work to electricity that it could supply to DC house. The children will be the ones providing the work without knowing that they are helping to produce electricity for the house. Further, the merry-go-round is a small part of a bigger project, as we can apply this basic to another way in energy production using the play actions of children in the playgrounds.

6.2. Design

As it has been mentioned before, the merry-go-round is going to be an energy generator to take advantage of the human mechanical energy to produce DC voltage in a clean way. Now the design is going to be analyzed level by level. From the most general to the most detailed one.

6.2.1. Level 1 Block diagram

In this level it is shown how humans produce mechanical energy by rotating the merry-go-round generator. This generator converts AC voltage to DC. Then, the DC will power a battery for different uses.

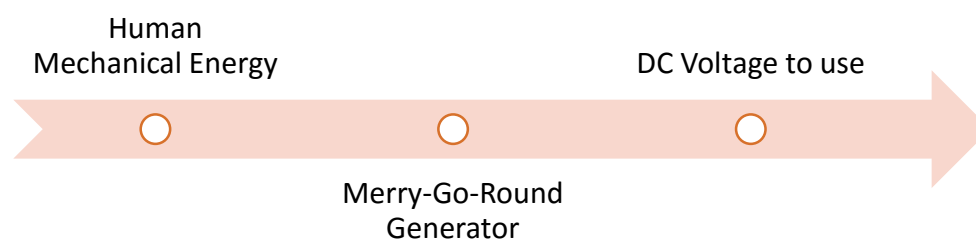

Figure 31. Level 1 Block Diagram of Merry-Go-Round

It describes all the functionalities and the main points of the block diagram in the text below:

Module. Is the merry-go-round.

Inputs. The human mechanical energy produced by the rotation of the module.

Outputs. The DC output is to charge the battery.

Functionality. The merry-go-round will produce power which will be rectified and regulated. This power will be connected to a DC battery.

6.2.2. Level 2 Block diagram

The next diagram shows how the energy that can be produced by humans, using a Dynamo Generator, a Rectifier and with two Boost/Buck converters, can be used for batteries, to illuminate parks or schools.

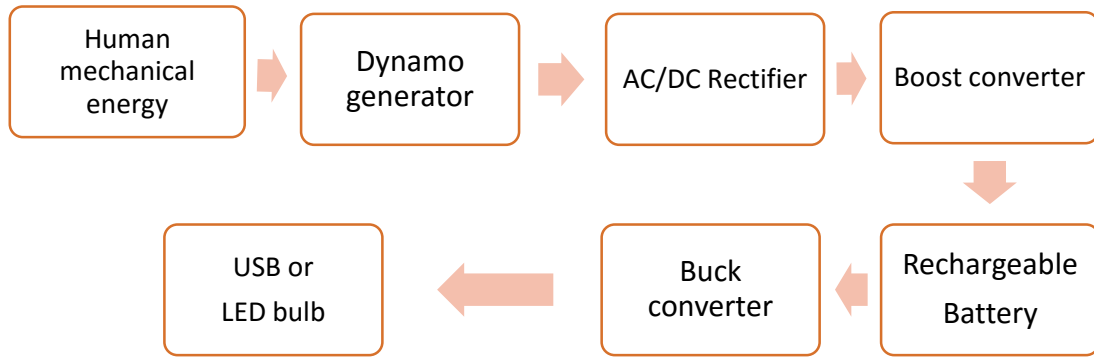

Figure 32. Level 2 Block diagram. The complete system of the Merry-Go-Round.

The mechanism is basically that of a Merry Go-Round, which rotates and spins a rotor from the Generator to produce AC voltage. This voltage needs to be rectified to a DC signal for the future uses. This is the function of an AC/DC rectifier, convert the signal from AC to DC. Then the DC voltage goes inside the boost converter circuit. In order to produce an output Voltage that helps step-up the desired output. The buck converter module will be used for testing purposes, it is used to step-down the voltage to the output wanted voltage.

The following section discusses the different material, electronic equipment and how they are connected within the system.

6.3. Electric circuit estimations

It is assumed that the merry-go round has a radius of 1500mm and an average of 10 laps per minute per child:

$$\omega = 10 \frac{\text{rev}}{\text{min}} \times \frac{2\pi \text{ rad}}{1 \text{ rev}} \times \frac{1 \text{ min}}{60 \text{ s}}$$

The angular velocity will be:

$$\omega = \frac{\pi}{3} \text{ rad/s}$$

Applying the formula of the angular velocity, the merry-go-round spins approximately with a linear velocity of:

$$\omega = \frac{v}{r} \text{ rad/s}$$

$$v = 1.6 \text{ m/s} = 5.76 \text{ Km/h}$$

In a dynamo generator the AC used is rated at 6V and 3W. A study has been done to obtain the output voltage with different speeds in a constant resistance load testing.

Table 13. Constant resistance load testing with 18 ohms¹⁹

Speed (km/h)	Output Voltage (V)
5	2.45
15	5.78
30	7.23

It is decided to take a range of voltages between 1V to 4V in alternate current because of the merry go round can spin in different velocities depending on the force that they rotate it.

Next, the rectifier convert the alternate current (AC) to a continuous current (DC) more or less equivalent with the output voltage rippled. Otherwise, it can be reduce this rippled with one capacitor. If it is not reduced this rippled, it can produce a little buzz for example in the audio equipment.

Then the boost converter steps up the output voltage from the rectifier and increases it to the desired voltage. In this proposed circuit an output voltage of approximately to 12V from the rectifier is needed to store it into a rechargeable battery of 12V.

In order to select the rechargeable battery, it has to be beard in mind that the majority of the dynamo generators with this characteristic have a 500mA output. Therefore, the requirement of rechargeable batteries is:

$$Ah = \frac{\text{Device's Wattage (W)} \times \text{Time to run (hours)}}{\text{Battery Voltage (V)}}$$

A higher unit of electricity charge in the battery (Ah) then the input current that enters in is needed, because in case the battery is charged with more current than allowed, it may cause damage to the plates or causes the battery to overheat or produce excessively gas.

Therefore, as an example the intention is to load an iPad, that it is rated at 12W and usually takes between 6 to 8 hours to a fully charge or to illuminate the park with LED bulb of 6W between 6 to 8 hours, a rechargeable battery is needed as in the following:

¹⁹ Source. http://www.seeedstudio.com/wiki/Bicycle_Dynamo_With_Bracket_-_6V_3W

Table 14. Batteries for the circuit design

Device's	Rechargeable battery of 12V
IPad – 12W – 8h	Rechargeable battery 12V 8Ah
LED bulb– 7W – 8h	Rechargeable battery 12V 5Ah

Finally, to charge the IPad properly, a buck converter has to be connected to the output of the battery to the desired value for the device. The input of the converter can cover approximately between 4V to 35V and the output between 1V to 30V. Therefore, it is possible to adjust the desired output voltage from the devices (5V for the USB), for the LED bulb it will not be necessary because it needs 12V input.

6.4. Financial study

To have an approximate idea of what this circuit design might cost, a general estimation of the necessary elements for the construction of the components for the electrical circuit has been made, without considering the merry-go-round mechanism.

Table 15. Financial study

Material	Cost to purchase			
	Optimistic	Realistic	Pessimistic	Estimate
AC Generator 6V – 3W	20€	30 €	50€	25€
AC – DC Rectifier	0,5 €	1 €	5 €	2,5 €
Boost Converter	10 €	14 €	20 €	17 €
Buck Converter	12 €	21 €	30 €	25 €
12V Rechargeable Battery 8Ah	10 €	16,71 €	25 €	20 €
12V Rechargeable Battery 5Ah	10 €	17,5 €	25 €	20 €
LED bulb	20 €	28.8 €	35 €	30 €
Total cost	82,5 €	129,01	190 €	139,5 €

In the table 13 the financial study about the circuit designed for generating electricity of the human mechanical energy is shown. It considers four dynamos, one buck converter, one boost converter, one AC-DC rectifier, the two different rechargeable batteries (12V-8Ah/12V-5Ah), and one LED bulb. (See appendix 2: 2.1. Materials selected.)

6.5. Hardware

6.6. Material and Electronic Equipment

In this section all the different materials and equipment that are used in this system and how they are connected are discussed.

6.6.1. Ac Dynamo Generator

The dynamo consists of a stationary structure that provided a constant magnetic field and a set of rotating windings spinning beside the field. In small machines, the magnetic field was delivered by one or more permanent magnets; in larger machines it is driven by electromagnets.

The AC generator uses the dynamo effect to produce energy in form of electricity. As it is known, a generator is described as an electric motor however working in reverse, instead of using electrical energy to produce kinetic energy but in this case, kinetic energy is used to produce electrical energy. Right after, it shows a diagram of an AC generator.

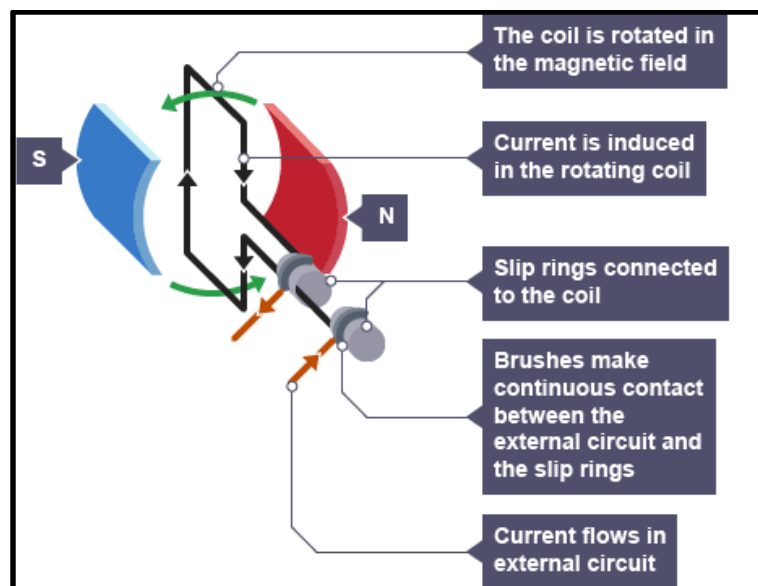

Figure 33. An AC generator²⁰. The slip rings are connected to the coil. The brushes are connected to the external circuit. The brushes touch the spinning slip rings, which maintain electrical contact between the coil and the external circuit.

²⁰ Source. BBC. GCSE Bitesize has changed; Home>Science>OCR Gateway Triple Science Topics>Electricity for gadgets>Generating. The AC generator. http://www.bbc.co.uk/schools/gcsebitesize/science/triple_ocr_gateway/electricity_for_gadgets/generatin/revision/2/

The use of the dynamo is necessary for converting the rotation to electricity. The rotation of the merry-go-round will spin a rotor causing the generator to produce an unregulated voltage. This one will then be rectified and fed into the boost to convert an AC regular output. Four dynamos can be used if they are put in the shaft below the merry-go-round.

If the Dynamos Generator is connected in parallel, it would allow more current flow through the circuit and help charge the battery faster.



Figure 34. AC dynamo generator.²¹

Table 16. AC Dynamo Generator

Module	AC Dynamo Generator 6V-3W
Inputs	The human mechanical energy produced by the rotation of the merry-go-round
Outputs	The AC output is between a ranges of voltages (1V-4V)
Functionality	The merry-go-round will produce power thanks of the conversion of the mechanical energy to AC electrical voltage

6.6.2. AC-DC Rectifier

Simply defined, a rectifier is an electrical device that converts the alternating current (AC) to direct current (DC), which flows only in one direction. This process is often called rectification that means a device only allows unidirectional flow of electrons. This only allows one half of an AC waveform to pass through the load.

²¹ Source. <http://www.amazon.com/Bike-Bicycle-Dynamo-Generator-12V/dp/B000OBWMGK>

The half-wave rectification is insufficient for most power applications, it is expected that in this project there is no need for a full wave rectifier. Instead the half-wave rectification is a simple way to reduce the power to a resistive load.

The output from the dynamo is AC voltage. This voltage will pass by a Rectifier that will convert the AC voltage to a DC voltage. We have to bear in mind that this voltage will be always equivalent to the output voltage AC ripple. This AC ripple can be reduced thanks to a capacitor filter.



Figure 35. Rectifier AC-DC.²²

Output Voltage AC ripple

After the electricity passes through the rectifier, we obtain half of the electrical wave. This wave has a little distortion due to the diode, since we have used a real and not an ideal one.

Due to the materials the diode has an electrical wave with distortion for the interaction with the harmonics of the materials of the diode. Trying to avoid this distortion would be a good idea because the battery will not get damaged in the use of years.

Capacitor filter

Therefore, trying to avoid distortion or ripple the best idea is adding a capacitor filter in the rectifier. This is a compensator put in parallel with the output. The idea is the following:

The capacitor will charge and discharge when the ripple goes up and down. The result will be a rectification of the ripple and, if we use the adequate capacitor we will practically avoid the completed ripple.

²² Source. Silicon Bridge Rectifier. <http://www.feeneyinc.com/Rectifier-Block-12V-DC#>

Table 17. AC-DC Rectifier

Module	AC-DC Rectifier
Inputs	AC voltage inside a range (1V-4V)
Outputs	DC voltage inside a range after the rectification signal (1V – 10V)
Functionality	The AC-DC rectifier convert the AC voltage to DC voltage with a peak value quite similar.

In the table 15, the AC-DC Rectifier describes all the functionalities of the Rectifier module. The Dynamo Generators sends a signal to the Rectifier AC-DC then, the Rectifier will convert it to a DC signal and avoid the AC output voltage ripple from the generator.

6.6.3. Boost Convert Module

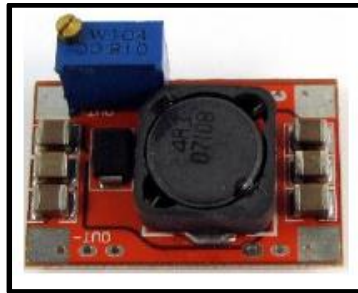

Figure 36. Boost Converter.²³

The Boost Converter Module is an electrical analogical circuit made with a switch or a mosfet, a capacitor a diode and a bovine. It has the following levels: The switch is open so the electricity does not pass by. The electricity goes through the bovine and charges the capacitor. This is when it turns off the pulse to the MOSFET.

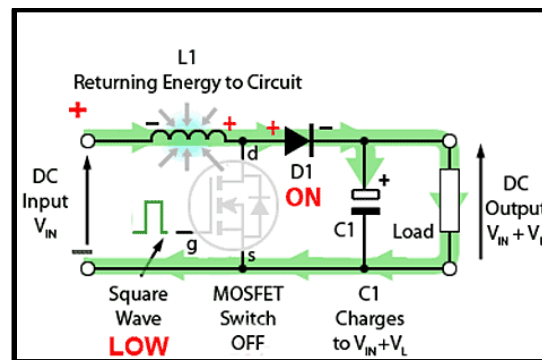

Figure 37. Current Path with MOSFET Off.²⁴

²³ Source. <http://www.digikey.es/suppliers/es/texas-instruments.page?lang=en>

²⁴ Source. <http://www.learnabout-electronics.org/PSU/psu32.php>

The switch is closed so the electricity passes through and returns to the circuit. Then, the capacitor discharges and gives the output voltage. Then the pulse is equal to 1.

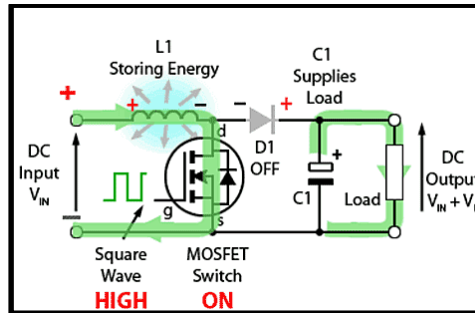

Figure 38. Current Path with MOSFET On.²⁵

The boost converter will take the small input voltage and step it up to the expected output voltage. It is expected to have a small AC output voltage ripple.

Table 18. Boost Converter

Module	Boost Converter
Inputs	DC Voltage inside a range with an AC ripple output
Outputs	A specific voltage output to charge a battery (12V-14V)
Functionality	The boost converter will step it up the small DC voltage to a DC specific voltage wanted.

6.6.4. Buck Converter module

The Buck Convert module is an electrical analogical circuit made with a switch or a mosfet, a capacitor a diode and a bovine. It has the following levels: The switch is closed so the electricity passes through and returns to the circuit. Then, the capacitor charges and the output voltage is the electricity that passes through the switch. Then the pulse is equal to 1. In the following picture, the scheme of the circuit is shown:

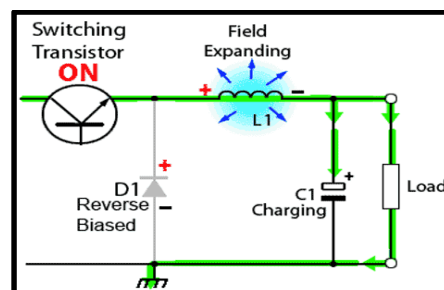

Figure 39. Switching Transistor 'on' Period.²⁶

²⁵ Source. <http://www.learnabout-electronics.org/PSU/psu32.php>

²⁶ Source. <http://www.learnabout-electronics.org/PSU/psu31.php>

The switch is open so the electricity does not pass by. The capacitor discharges and gives the output voltage. Now, the pulse goes out and is equal to 0. In the following picture, the scheme of the circuit is shown:

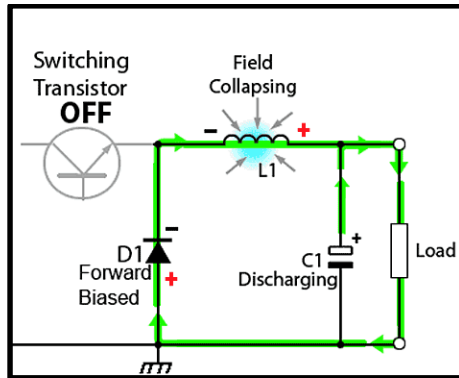

Figure 40. Switching Transistor 'off' Period.²⁷

The buck converter module will be used to take the input voltage and decrease it to the output wanted voltage.

Table 19. Buck Converter

Module	Buck Converter
Inputs	DC Voltage
Outputs	A specific voltage output to a USB port (5V)
Functionality	The boost converter will step down the voltage output

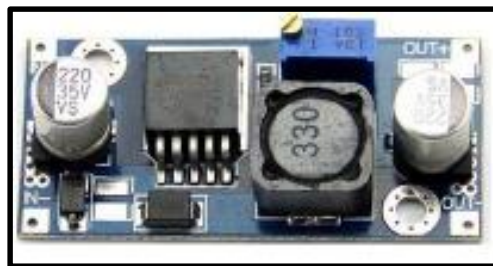

Figure 41. Buck Converter.²⁸

²⁷ Source. <http://www.learnabout-electronics.org/PSU/psu31.php>

²⁸ Source. <http://www.aliexpress.com/item/LM2596-DC-Step-Down-Voltage-Converter-Circuit-Board-3-2-40V-to-1-25-37V-Regulator/609516218.html>

6.7. Conclusions and recommendations

After the efficiency study it is possible to convert the mechanical energy from a child into electricity, with the merry-go-round principle. After implementation of the designed circuit, it is needed to evaluate all circuits in the simulation program to confirm that all designs are correct, no errors occur and it is efficient. If proven correct, it should be considered to generate sufficient electricity to satisfy the people either with illumination of public places or to charge mobile devices.

From the opposite view, it could be said that all this energy generated is only in a small-scale, also this amount of energy is calculated with 6 km/h, which for the children is a considerate velocity, but it has to be taken in consideration that the output electricity generated calculated before is in one hour in constant motion.

Therefore, two circuits are designed with two dynamos each, which they would be coupled in the four shafts down of the merry-go-round. There the two results suggested it could be obtained. On the one hand, providing electricity for illuminating parts of the playground where the merry-go-round would be situated, and on the other hand, for parents to charge their mobile devices such as tablets, mobile phone, speaker to listen music, etc.

Finally, the two circuits that could provide electricity in a clean way are:

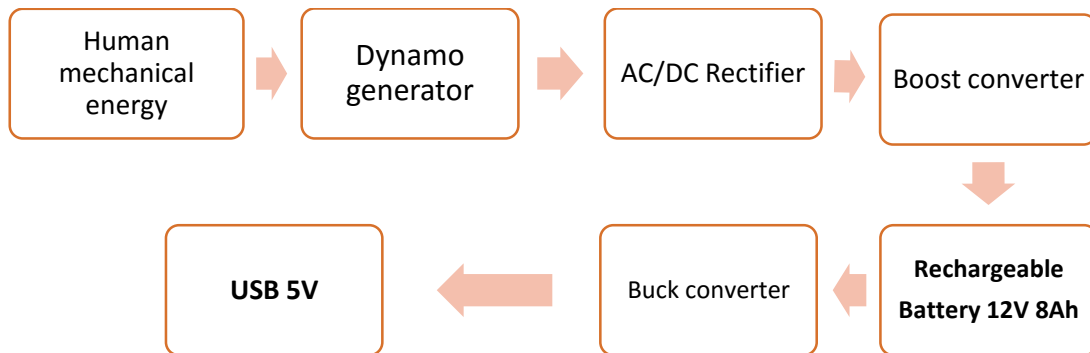

Figure 42. Circuit design for the USB connection.

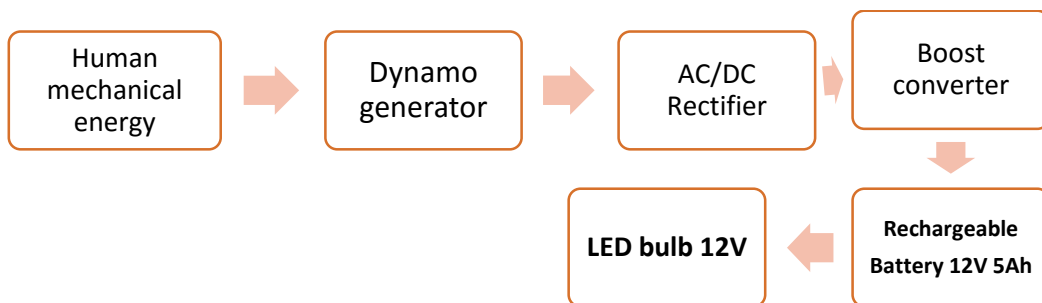

Figure 43. Circuit design for the LED Bulb.

7. Other ways of capturing human kinetic energy

The aim of this chapter is the demonstration of the feasibility to generate energy on the floor through footsteps of people. In the long term it could revolutionize power generation systems in the form of massive installation of piezoelectric devices under the asphalt. This principle can be applied to roads, highways, railways, airports and the generation could be achieved not only by the footsteps of the people but also with vehicles such as trains and even planes as it is already developed elsewhere.

7.1. Introduction

This chapter describes the advantage of capturing human kinetic energy, for example, the endless resource of energy through piezoelectric tiles on the floor at children's playgrounds. One way to save energy and make use of sustainable energy in a clean way is to start using this system of piezoelectric tiles. This technology is relatively new in terms of social knowledge. It is basically the "use of crystals, natural or artificial, that when is submitted with a mechanical stress (treads of the people) release electrical charges".

How many people pass through the center of a city, the subway entrance, hallways schools or playgrounds floors? All this effort is wasted energy, for this reason, this project aims to use this energy trying to create a system, which transforms and takes this "resource" into electrical energy.

Nevertheless, the piezoelectric materials as power generators are under development, although they are a reality, they still need more time to be competitive in the market system. With the evolution and the research of these materials, these will become an option for the world to generate electricity.

7.2. Antecedents

Around the world there are many companies specialized in developing methods to take advantage of the mechanical energy generated by the piezoelectric plates for railways, runways and automobiles or pedestrian traffic. These plates operate by mechanical stresses that are obtained by putting down certain crystals in a certain pressure to acquire an electric polarization in its mass and give rise to a potential difference generated by electrical charges on its surface.

Consequently, the plates take advantage of the pressure exerted naturally by certain human activities to transform it into electrical energy that can be stored and it can be used for different applications. It is based on the large amount of movement that can occur daily in crowded areas like train stations, subway stations, bus stations, airports, schools or shopping centers.

There are many projects related to electricity production using footsteps, for example the summer 2013, this intelligent system was implanted near the access to the Olympic Park in London where twelve million football fans produced around seventy two millions of Jules. This is enough to charge ten thousand mobile phones for one hour of energy.

After the project in London, they got more evidence in mass and promotional events, from the Paris Marathon to Earth Hour held at the Marina Bay in Singapore. In the UK and Europe, they have developed nearly 30 projects from 'Pavegen'²⁹ either permanent or temporary. [ABC.es – SCIENCE/Invents/Intelligent Tile.]

The East Japan Railway Company has installed a piezoelectric pavement in the turnstiles and the entrance gates at the Tokyo subway that serves the purpose of generating electrical energy. The total amount of surface employed for this system is approximately of 25m² and estimated to be generating up to 0,4 kWh a day.



Figure 44. Conceptual drawing of the piezoelectric floor in traffic areas.³⁰

Energy efficiency systems that work with pedestrians, automobiles and railway traffic have been developed by Technion institute of technology and later on by the Israeli company Innovatech. This energy conversion system for the road traffic consists in introducing several piezoelectric elements in a way where its surface is placed 3cm underneath the pavement. These generators are wired to a number of batteries placed outside the system so that the energy can be stored for later use in the electrical grid.

Following the same structure, a piezoelectric generator was placed in the heel of a shoe, dedicating amount of energy generated to charge a battery by J. Paradiso and N.S. Schenk. The device installed in the shoe managed to get 11% of efficiency.

²⁹ <http://www.pavegen.com/>

³⁰ Source. <http://www.ingenieriaverde.org/genera-energia-con-solo-caminar/>

Another application for this kind of technology can be found in what is known as WATT club, based in the model of the Sustainable Dance Club, which franchises ecological clubs. This is a project where piezoelectric materials form the dance floor of nightclubs so that the energy from each step can be stored and later be used for the basic utilities of the local municipality and save up to 10% of the energy consumption.

7.3. Piezoelectricity

What is a piezoelectric material?

A piezoelectric material is a crystalline element which by submitting an effort mechanical acquires an electrical polarization and a difference potential appears which produces electrical energy.

7.4. Introduction to the piezoelectric phenomenon

Piezoelectric materials have an induced polarization by an external electric field, the polarization is also produced under the influence of the mechanical stress. When a piezoelectric material is deformed, it is produced a displacement of the charged particles, resulting in a dipolar moment in the material and influence on opposite charges facing surfaces thereof.

In addition, the crystals are given the reverse piezoelectric effect resulting of a material deformation by applying an electrical voltage. When the material is subjected to an electric field an internal forces on the loads that constitute the crystal appears, and the loads will change their position, producing a mechanical deformation of the crystal.

7.5. Piezoelectric materials properties

The materials that present piezoelectric properties are divided into two groups: those with present properties in the natural way and those that need to be polarized (which are the piezoelectric ceramic). The first have a very small piezoelectric effect. For that reason a second alternative with a greater effect was developed.

In the industry, titanate barium (BaOTiO_2) and the combination of zirconate lead (PbZrO_3) and titanate lead (PbTiO_3) are most used. This combination is called PZT (zirconate titanate of lead) and are manufactured by powder compression at high temperature, molded and baked in an oven.

The PZT

The PZT has an advantage over the other ceramics as it can be manufactured at a very low price, is physically strong and chemically inert. Further, it has shown to be more sensitive than other piezoelectric ceramics.

7.6. Piezo generators

The piezo generators are static machines, which convert mechanical force and movement into voltage. The piezo generators can be configured in layers or in multi layers, connected in series or parallel.

7.6.1. One layer piezo generators

When in the longitudinal directional (parallel polarization), a mechanical stress is applied to one layer piezo ceramic; it generates a voltage that tries to return to its original thickness. It is obtained a longitudinal piezo generator.

Table 20. Forces of the longitudinal Piezo generator

V_{out}	Output Voltage
F_{in}	Applied Force
P	Pressure
ΔT_{in}	Layer Thickness

7.6.2. Multi layers Piezo Generators

When mechanical stress in two-layer laminate is applied it results in an electrical generation depending on the direction of the force, of the polarization direction and the wiring of the individual layers. The wiring for two layers in a series that uses only two wires, each one is attached to each outer electrode. The wiring for two layers in parallel, requires three wires, one attached to each outer electrode and the other connected to the support plate center.

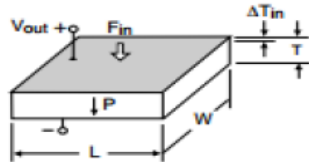

Figure 45. Function of the longitudinal Piezo generator.³¹

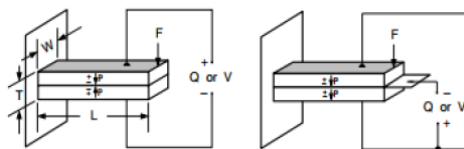

Figure 46. Two layer generators. 1) Series connection, 2) Parallel connection.³²

³¹ Source. <http://www.piezo.com/catalog7C.pdf>

³² Source. <http://www.piezo.com/catalog7C.pdf>

7.7. Use the piezoelectric tiles to harvest energy

7.7.1. Introduction

For energy harvesting piezoelectric effect is widely used. Companies like PowerLeap, Pavegen, Innowattech and others have developed trading systems pavement which generate electricity under this effect.

The generation of the electric energy with the help of piezoelectric tiles depends on at least two groups of variables: constructive aspects of the tile and the particularities of human walking.

7.7.2. Principle of the operation of the piezoelectric tiles

The tile consists of two aluminum plates separated between 4 to 10 mm and with the ability to move relative to each other when it is footfalls. In the middle of the plates the piezoelectric material is located.

When pressure is applied on the tile, the plates move and trigger the piezoelectric material where the mechanical energy is converted to electrical energy.

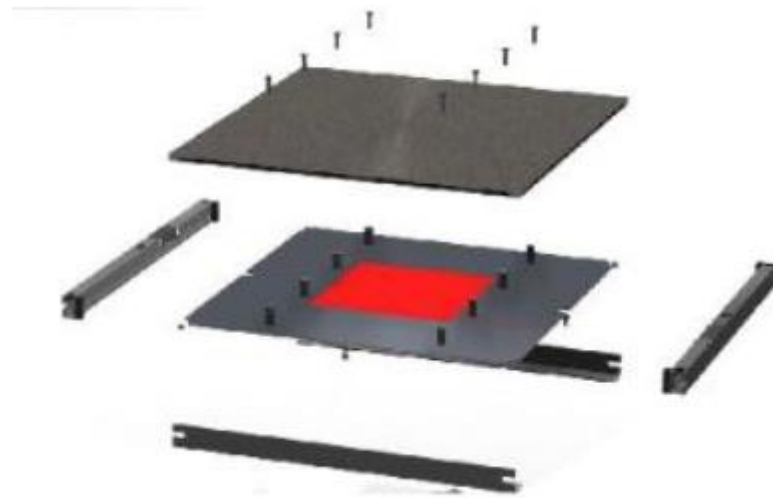

Figure 47. Mechanical scheme and piezoelectric tile. The piezo electrical material is placed between two aluminum plates.³³

³³ Source. POWERleap Product. Source. POWERleap SmartFloor Overview 2011

7.8. Description of a piezoelectric tile PowerLeap

The piezoelectric tile PowerLeap (figure 51), is assembled on an aluminum structure of 3 cm high, 50 cm wide and 50 cm long which supports up to 100 KN of weight. This structure consists of two metal plates of aluminum of 3 and 4 mm thickness, which can be moved to 5 mm over the whole surface (when they are footsteps). Between the two plates the piezoelectric material is embedded.



Figure 48. Piezoelectric tile PowerLeap³⁴

The piezoelectric material used, is a compound of piezoelectric microfibers (MFC) developed by the NASA Langley Research Center. The MFC consists of fine fibers PZT embedded in an adhesive polymer film and covered with a pattern of interdigitated electrodes.

The piezoelectric fibers have rectangular transversal sections with regular space and parallel line-up precision. The polymer film combines electrical, thermal, chemical and mechanical properties for environments with extreme temperatures and vibrations.

As a result, the MFC have a higher electromechanical coupling coefficient and produce force at a higher shift than any other compound. A PowerLeap tile, has a MFC with 8.4 cm long and 8.3 cm wide that is parallel polarized. A PowerLeap tile is designed for the use of 20 years or more and the manufacturer estimates a positive payback between 3 to 5 years.

³⁴ Source. POWERleap Product. Source. POWERleap SmartFloor Overview 2011

Results and general Conclusions

8. Results and conclusions

From the mechanical point of view, it is possible to design a playground where the mechanical energy is obtained to illuminate the park or to charge different types of devices. This study has not taken into account the economical aspect, except in the case of the merry-go-round. In this case, the feasibility of the system has shown to be relatively high, since the elements used are inexpensive.

Nevertheless, throughout the study different assumptions have been made in order to simplify the calculations of the systems. In the case that the project would be carried out by a group of experienced engineers in this sector the assumptions might be argued. In addition, the uses of sensors and other measurement devices would make the study more realistic.

Moreover, if the project was going to be carried out, it would be necessary to perform both an economical study and a safety study. Regarding the economical study it is obviously important to know the prior investment amount needed and the exact payback period. Regarding the safety study, it must be ensured that the structure of the swing will not break or fall. Otherwise, the engineer in charge of the project would be held responsible for any accident. Furthermore, before building or commercializing this technology at a large scale, it is necessary to study the behavior of a prototype of each design.

From an environmental point of view, it can be said that the main goals of creating a sustainable playground have been achieved. In addition, it has been only possible to study the swing and the merry-go-round; however, there are still many other designs to develop for other kind of games. Nonetheless, this project could be largely developed in order to find new alternatives to generate electricity.

Moreover, this initiative would hopefully have a positive impact on growing up children. Nowadays, the global awareness on environmental impacts and economic cost of generating electricity increases steadily. This attempt shows a greener vision of energy generation.

Furthermore, the results that have been obtained do seem to be fairly realistic. In the merry-go-round, a system to charge electronic devices has been established. Besides, some of this energy would be stored in small batteries to use to illuminate the playground. The results from the swing have shown to be fairly good; with only 1 hour working at the highest rate it is possible to illuminate the park from 10 hours onwards.

Literature references

Cabrera Pérez, D., Díaz Torres, M., García Déniz, R., Hernández Rodríguez, C., Martel Rodríguez, Gilberto., Pardilla Fariña, J., Pernavieja Izquierdo, G., Schallenberg Rodríguez, J.C., Subiela Ortin, V. (2008). *Énergías renovables y eficiencia energética*. Instituto Tecnológico de Canarias, S.A.

CFF Conserve Energy Future. Non-renewable energy source.
<http://www.conserve-energy-future.com/NonRenewableEnergySources.php>
(Retrieved: 1.4.2016)

Chapman, Stephen J (2000). *Máquinas Eléctricas*. Colombia: Mc Graw Hill.

CO.EXIST. (2012, Jun., 25). 6 future Playgrounds.
<http://www.fastcoexist.com/1680066/6-future-playgrounds-that-harness-kids-energy-while-they-play/1> (Retrieved 5.3.2016)

Conservation of Energy (2003). McGraw-Hill Dictionary of Scientific & Technical Terms, Copyright ©. McGraw-Hill Companies, Inc.

Energy Floors. Sustainable dance club, energy floors.
<http://www.sustainabledanceclub.com/> (Retrieved 18.3.2016)

Empower, Playgrounds, Inc. Merry-Go-Round.
<http://www.empowerplaygrounds.org/mgr/> (Retrieved 5.3.2016)

Fouled García, J. (1994). *Acumuladores electroquímicos*. s.l.: McGraw-Hill.

Interempresas, metalmecanica. Un Sistema de almacenamiento avanzado.
<http://www.interempresas.net/MetalMecanica/Articulos/33346-Un-sistema-de-almacenamiento-avanzado-de-energia-cinetica.html>
(Retrieved 18.3.2014)

Johnson Matthey, Piezo Product. (2008). Energy Harvesting.

Learning about Electronics. Filter Capacitor.
<http://www.learningaboutelectronics.com/Articles/Filter-capacitor.php>
(Retrieved 15.3.2016)

Lloyd J. (2004). Electrical Properties of Macro-Fiber Composite Actuators and Sensors. Masters of Science in Mechanical Engineering. Virginia Polytechnic Institute. Blacksburg, Virginia.

Losty, H.H.W & Lewis, D.L. (1973). Philosophical Transactions for the Royal Society of London. Homopolar Machines. Mathematical and Physical Sciences.

Mellado, A. (2013, May, 27). Baldosas inteligentes generadoras de electricidad, SCIENCE/Invents/Intelligent Tile. ABC

O'callaghan, J. (2014, Sep., 11). MailOnline. Kinetic football field.
<http://www.dailymail.co.uk/sciencetech/article-2752022/Pitch-black-start-playing-Kinetic-football-field-harnesses-players-energy-power-night-time-lights.html>
(Retrieved 5.3.2016)

Pavegen. Company which harvest kinetic energy from the footsteps.
<http://www.pavegen.com/>. (Retrieved 29.3.2016)

Pérez Bello, A., Sainz Ruiz, J.A., Vilá Verdaguer, J., Zumárraga Lizundia, R. (1998). Piezoelectric, Energy-harvesting. Escuela Técnica Superior de Ingeniería (ICAI-Instituto Católico de Artes e Industria). Universidad Pontificia Comillas de Madrid.

Planeta Vital, (2003, Oct, 18). La energía de los niños genera electricidad.
<http://tuplanetavital.org/actualidad-planetaria/la-energia-de-los-ninos-genera-electricidad-luciernagas-de-ghana/> (Retrieved 2.3.2016)

Redmond, E., Powerleap. (2011). Fully integrated Energy Harvesting & Data Tracking Floor systems. Product Design and Development Overview.

Romaní Martínez, L.F., Domarco Álvarez, G. (2008). Acumuladores de energía mediante discos magnéticos superconductores. OTRI, Universidad de Vigo.

Schellen, H., Nathaniel S.K., (1884). Dynamo-Electric Machines and Magneto-Electric, Vol. 1, translated from German by Nathaniel Keith.

Alquimia. (2011, Jun., 01)). Selected Science News. Harvesting energy from passing train.
<http://www.scitech-news.com/2011/01/harvesting-energy-from-passing-train.html>
(Retrieved 5.3.2016)

Shingley, J. E. & Mischke, C. R. (2002). Diseño ingeniería mecánica. Mc Graw hill.

Sodano H., Park G, Inman D. Investigation into the performance of microfiber composites.
<http://www.me.mtu.edu/~hsodano/Publications/MSSP%202003%20MFC%20Applications.pdf>. (Retrieved 1.4.2016)

Swanson, S. (2007, Oct., 15). Harvesting Pedestrian Power. MIT, Technology Review.
<https://www.technologyreview.com/s/408860/harvesting-pedestrian-power/> (Retrieved 13.3.2016)

SWING, moradavaga (SWING). Guimaraes 2012 – European Capital of Culture.
<http://moradavaga.com/SWING> (Retrieved 5.3.2016)

UFF ECOLOGIA. (2016, Jan., 26). Columpio generador de energia, alimenta bomba de agua.
<http://www.uffmag.com/columpio-generador-de-energia-alimenta-bomba-de-agua/>
(Retrieved 1.3.2016)

Tables

Table 1. Advantages and disadvantages of the gears	12
Table 2. Efficiency of the gears.	14
Table 3. Assumptions for the energy balance	20
Table 4. Assumptions for the calculation of the reaction on the cogwheel	22
Table 5. Necessary data before the calculation of the reactions on the roller bearings	24
Table 6. Values of the radial loads	26
Table 7. Data to calculate the bending moments in the both Cartesian coordinate systems	29
Table 8. Results of the bending moment X-Y	30
Table 9. Results using the software "Barras"	31
Table 10. Results of the bending moment X-Z	32
Table 11. Results using the software "Barras"	32
Table 12. Data assumption	37
Table 13. Constant resistance load testing with 18 ohms	42
Table 14. Batteries for the circuit design	43
Table 15. Financial study	43
Table 16. AC Dynamo Generator	45
Table 17. AC-DC Rectifier	47
Table 18. Boost Converter	48
Table 19. Buck Converter	49
Table 20. Forces of the longitudinal Piezo generator	55
Table 21. Resistance fatigue	iv
Table 22. Types of shaft	vi
Table 23. Resistance fatigue	ix
Table 24. Types of shaft	xi

Figures

Figure 1. Speed multiplier.	7
Figure 2. Driveshaft or propeller shaft.	8
Figure 3. a) Fix solid shaft; b)Rotatory solid shaft; c)Solid shaft; d)Gap shaft.	9
Figure 4. Roller bearing.	10
Figure 5. Roller bearing classification	11
Figure 6. Different loads that can support the Roller bearing.	11
Figure 7. Drawn cup roller clutch.	12
Figure 8. Different types of gears.	13
Figure 9. Representation of a cylindrical gear with straight teeth.	14
Figure 10. Rotor and stator.	14
Figure 11. Components of the driveshaft	17
Figure 12. Potential energy due to gravity	19
Figure 13. Diagram of the energy balance from 1 to 2	21
Figure 14. Diagram to calculate the torque.	22
Figure 15. Cogwheel assembly	23
Figure 16. Reactions on the cogwheel of the driveshaft	23
Figure 17. Reaction on the driveshaft	24
Figure 18. Diagram with the distance between the elements of the driveshaft.	24

Figure 19. Diagram of the X-Y Cartesian coordinate system of the driveshaft-	25
Figure 20. Diagram of the X-Z Cartesian coordinate system of the driveshaft	25
Figure 21. Different types of cylindrical roller bearing.	27
Figure 22. Characteristics of roller bearings	27
Figure 23. Characteristics of roller bearings	28
Figure 24. Classification of roller bearings	29
Figure 25. Load diagram on the driveshaft (Cartesian coordinate system Y-Z)	30
Figure 26. Diagram of the bending moment M_z .	31
Figure 27. Load diagram on the driveshaft (Cartesian coordinate system X-Z)	31
Figure 28. Diagram of the bending moment M_y .	32
Figure 29. Diagram of the torque moment M_t .	32
Figure 30. Drawings of the principals views of the driveshaft and roller bearings	36
Figure 31. Level 1 Block Diagram of Merry-Go-Round	40
Figure 32. Level 2 Block diagram. The complete system of the Merry-Go-Round.	41
Figure 33. An AC generator. The slip rings are connected to the coil. The brushes are connected to the external circuit. The brushes touch the spinning slip rings, which maintain electrical contact between the coil and the external circuit.	44
Figure 34. AC dynamo generator.	45
Figure 35. Rectifier AC-DC.	46
Figure 36. Boost Converter.	47
Figure 37. Current Path with MOSFET Off.	47
Figure 38. Current Path with MOSFET On.	48
Figure 39. Switching Transistor 'on' Period.	48
Figure 40. Switching Transistor 'off' Period.	49
Figure 41. Buck Converter.	49
Figure 42. Circuit design for the USB connection.	50
Figure 43. Circuit design for the LED Bulb.	50
Figure 44. Conceptual drawing of the piezoelectric floor in traffic areas.	52
Figure 45. Function of the longitudinal Piezo generator.	55
Figure 46. Two layer generators. 1) Series connection, 2) Parallel connection.	55
Figure 47. Mechanical scheme and piezoelectric tile. The piezo electrical material is placed between two aluminum plates.	56
Figure 48. Piezoelectric tile PowerLeap	57
Figure 49. Low-Tech system	ii
Figure 50. Catalogue Roller bearings	iii
Figure 51. Performance comparision of roller bearings	iv
Figure 52. Boundary dimension of roller bearings (roller clutches)	iv
Figure 53. Influence factor b_0 in the relation with the fatigue resistance	v
Figure 54. Coefficient α_0	v
Figure 55. Influence factor b_0 in the relation with the fatigue resistance	ix
Figure 56. Coefficient α_0	ix

Appendixes

Appendix 1

1.1 Low-Tech system. Project SWING / Moradavaga

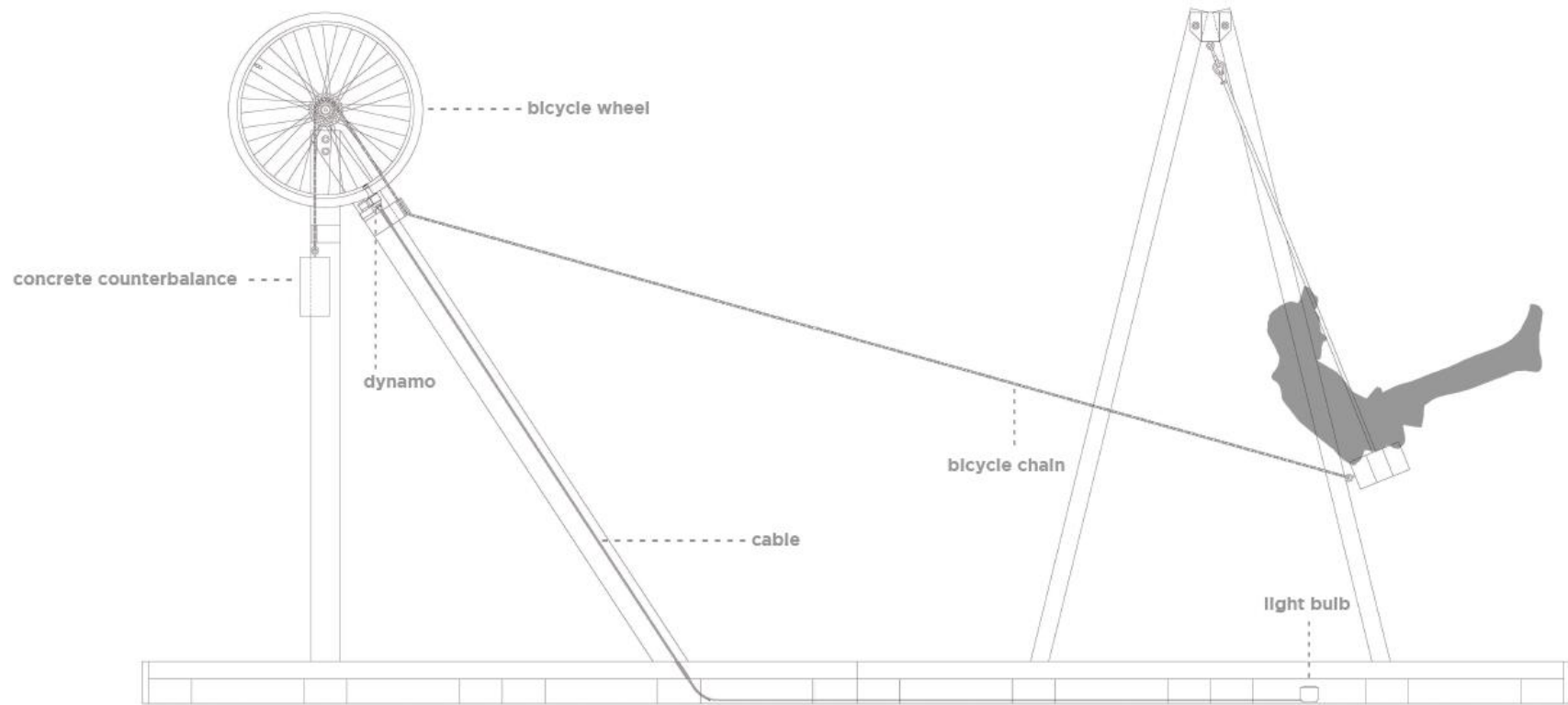

Figure 49. Low-Tech system

1.2 Calculation of the dimensioning on request dynamic of roller bearings.

As the roller bearings “B” and “E” only support radial loads:

$$P = B_r = 911,012 \text{ N}$$

$$P = E_r = 960,679 \text{ N}$$

$$L_{10} = L \approx 21 = \left(\frac{C}{911,012 \text{ N}} \right)^{\frac{10}{3}} \rightarrow C = 2,3 \text{ KN}$$

$$L_{10} = L \approx 21 = \left(\frac{C}{960,679 \text{ N}} \right)^{\frac{10}{3}} \rightarrow C = 2,4 \text{ KN}$$

It is entered the value of C in the tables on page 276 of the catalogue “Rodamientos Frag” and is removed the inner diameter of the roller bearings “B” and “E”.

Rodamientos FAG de rodillos cilíndricos de una hilera

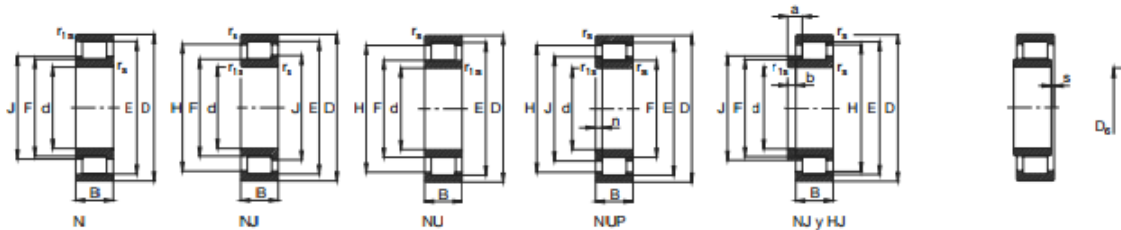

Eje	Dimensiones													Peso		Capacidad de carga	
	d	D	B	r _a min	r _b min	E	F	H	J	n	a	b	s')	Roda- miento	Anillo angular	C	estát. C ₀
	mm													kg	kg	kN	
15	15	36	11	0,6	0,3	30,3	19,3		21,6				0,5	0,047		12,7	10,4
	15	36	11	0,6	0,3	30,3	19,3	28	24,9	3	2,5	1,5	1,5	0,048	0,009	12,7	10,4
	15	36	11	0,6	0,3	30,3	19,3	28	24,9	3	2,5	1,5	1,5	0,048	0,009	12,7	10,4
17	17	40	12	0,6	0,3	35,1	22,1		24,9				1,2	0,068		17,6	14,6
	17	40	12	0,6	0,3	35,1	22,1		24,9				1,2	0,07	0,009	17,6	14,6
	17	40	12	0,6	0,3	35,1	22,1		24,9	5,5	3		1,2	0,069		17,6	14,6
	17	40	12	0,6	0,3	35,1	22,1		24,9	2,5			1,2	0,073		17,6	14,6
	17	40	16	0,6	0,3	35,1	22,1	32,5	24,7		6	3	1,7	0,053	0,01	24	22
	17	40	16	0,6	0,3	35,1	22,1	32,5	24,7				1,7	0,051		24	22
	17	40	16	0,6	0,3	35,1	22,1	32,5	24,9	3				0,055		24	22
	17	47	14	1	0,5	40,2	24,2	37,1	27,8		6,5	4	1,2	0,124	0,012	25,5	21,2
	17	47	14	1	0,5	40,2	24,2	37,1	27,8				1,2	0,122		25,5	21,2
	17	47	14	1	1,1	40,2	24,2	37,1	27,8	2,5				0,127		25,5	21,2

Figure 50. Catalogue Roller bearings

$$\phi_B = \phi_E = 15 \text{ mm}$$

1.3 Calculation of the dimensioning on request dynamic of roller clutches.

As the rolling clutches “C” and “D” only support radial loads:



















Bearing types	Deep groove ball bearings	Angular contact ball bearings	Double row angular contact ball bearings	Duplex angular contact ball bearings	Self-aligning ball bearings	Cylindrical roller bearings
Characteristics						
Load Carrying Capacity						
Axial load						

Figure 51. Performance comparison of roller bearings

$$C_r = D_r = 953,321 \text{ N} = 0,9 \text{ KN}$$

It is entered the value of C_r in the tables on page B-80 of the catalogue “NTN – Ball and Roller Bearings” and is removed the inner diameter of the roller clutches “C” and “D”.

d 20 ~ 40mm

Boundary dimensions	Basic load ratings								Limiting speeds ¹⁾		Bearing numbers ²⁾					
	mm		dynamic		static		dynamic		static		min ⁻¹		type	type	type	type
d	D	B	$f_{10 \text{ min}}^{(3)}$	$f_{10 \text{ min}}^{(3)}$	C_r	C_{0r}	C_r	C_{0r}	C_r	C_{0r}	grease	oil	NU	NJ	NUP	N
20	47	14	1	0,6	25,7	22,6	2 620	2 310	15 000	18 000			NU204E	NJ	NUP	—
	47	18	1	0,6	30,3	28,3	3 100	2 890	14 000	18 000			NU2204E	NJ	NUP	—
	52	15	1,1	0,6	31,5	26,9	3 200	2 740	13 000	15 000			NU304E	NJ	NUP	—
	52	21	1,1	0,6	42,0	39,0	4 300	3 950	12 000	14 000			NU2304E	NJ	NUP	—

Figure 52. Boundary dimension of roller bearings (roller clutches)

$$\phi_C = \phi_D = 20 \text{ mm}$$

1.4 Dimensioning the diameter of the driveshaft at point B.

$$1. \text{ Table 19. } \sigma_B = 450 \frac{\text{N}}{\text{mm}^2} \rightarrow \sigma_W = 210 \frac{\text{N}}{\text{mm}^2} \rightarrow \rho^* = 0,09 \text{ mm}$$

Table 21. Resistance fatigue

TABLA 73. Resistencia a la fatiga por tracción y compresión σ_w y radio e^* , de las entalladuras equivalentes en materiales tenaces (acero)

$\sigma_B \text{ N/mm}^2$	300	350	400	450	500	600	700	800	900	1000	1100	1200	1300
$\sigma_w \text{ N/mm}^2$	140	170	190	210	230	270	320	360	410	450	500	550	600
$e^* \text{ mm}$	0,2	0,15	0,12	0,09	0,08	0,06	0,04	0,03	0,025	0,02	0,02	0,015	0,01

$$2. \text{ Figure 54. } \sigma_B = 450 \text{ N/mm}^2 \rightarrow b_0 = 0,88$$

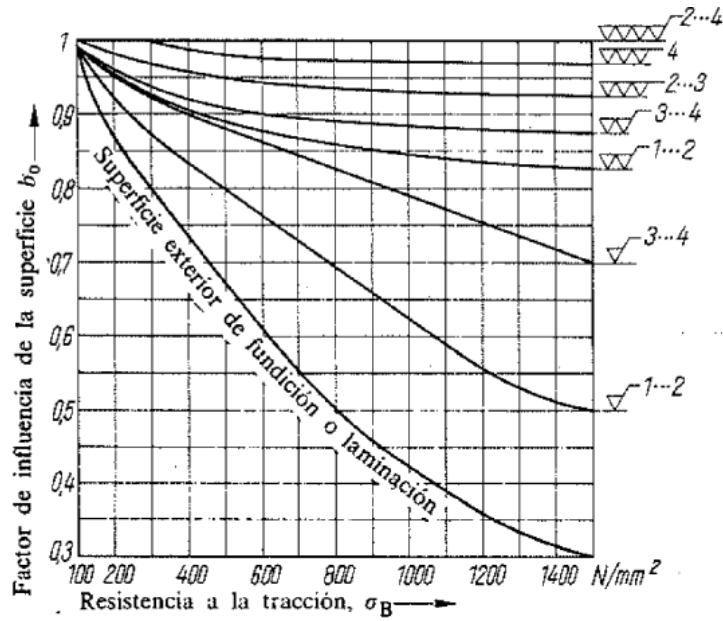

Figure 53. Influence factor b_0 in the relation with the fatigue resistance

3. Considering $d = 20 \text{ mm}$ and with the figure 57.



FIGURA 190
Coeficientes de forma de la entalladura α_{kb} , de ejes con escalones.

Figure 54. Coefficient α_0

α_{kb} :

$$\frac{d}{D} = 0,8 \rightarrow D = 25 \text{ mm}; \rho = 2 \text{ mm}; t = 4 \text{ mm} \rightarrow \frac{\rho}{t} = 0,5 \rightarrow \alpha_{kb} = 2$$

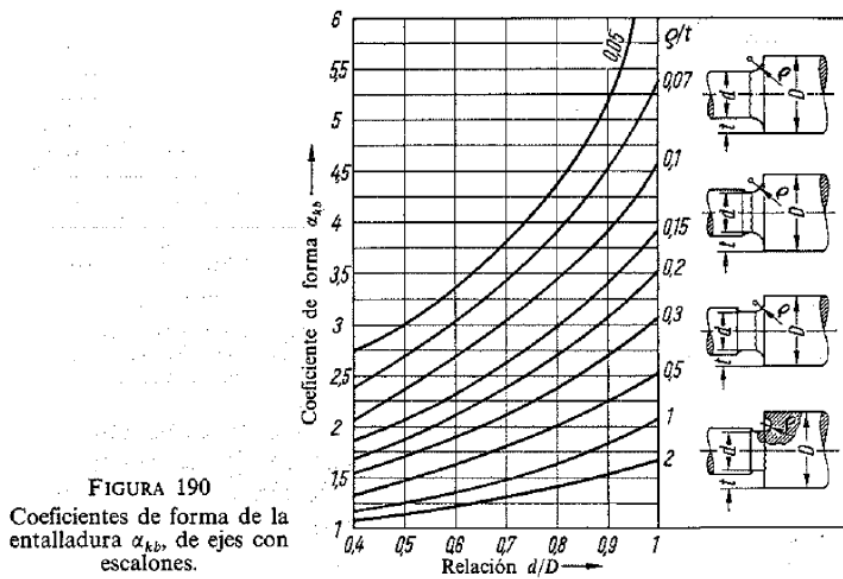
χ :

Considering torque, more unfavorable:

$$\chi = \frac{2}{20} + \frac{1}{2} = 0,6 \text{ (considering the torque equation)}$$

$$4. \beta_{xb}: \quad \beta_{xb} = \frac{\alpha_{kb}}{1 + \sqrt{\rho^* \cdot \chi}} = \frac{2}{1 + \sqrt{0,09 \cdot 0,6}} = 1,62 \text{ mm}$$

$$5. R = \frac{\sigma_m}{\sigma_0}. \text{ Considering } R = 0,5 \text{ (Pulsatory moments)}$$

$$6. \sigma_G:$$

$$\sigma_G = \frac{210 \cdot 0,88}{1,62 \cdot (1 - 0,5)} = 227,74 \frac{N}{\text{mm}^2} \rightarrow \sigma_{adm} = \frac{\sigma_G}{C_S}; C_S = 1,3$$

$$\sigma_{adm} = \frac{227,74}{1,3} = 175,19 \text{ N/mm}^2$$

$$\sigma_v = \sqrt{\sigma_0^2 + (3\alpha_0^2)\tau_t^2}$$

$$7. M_b = \sqrt{(M_B)_y^2 + (M_B)_z^2} = \sqrt{39,33^2 + 14,31^2} = 41,85 \text{ N} \cdot \text{m}$$

$$\sigma_0 = \frac{M_b}{W_b} + \frac{N}{\frac{\pi d^2}{4}} = \frac{41,85 \cdot 10^3}{800} + \frac{0}{\frac{\pi \cdot 50^2}{4}} = 52,31 \text{ N/mm}^2$$

$$3\alpha_0^2: \text{ (Considering pulsatory torque and bending): } \alpha_0 = 1$$



$$\tau_t = \frac{M_t}{W_t} \rightarrow \tau_t = \frac{52,43 \cdot 10^3}{1.600} = 32,77 \text{ N/mm}^2$$

$$W_b = 0,1 \cdot d^3 = 800 \text{ mm}^3$$

$$W_t \rightarrow \text{table 20} \rightarrow W_t = 0,2 \cdot d^3 \rightarrow 0,2 \cdot 20^3 = 1.600 \text{ mm}^3$$

Table 22. Types of shaft

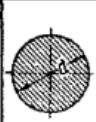
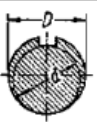
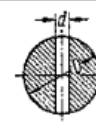
TABLA 71. Momentos de resistencia W_b y W_t contra flexión y torsión, así como momentos de inercia I_b y I_t en distintas secciones de ejes

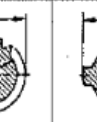
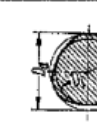
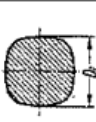
							
	Ejes lisos	Eje ranurado	Eje con orificio transversal	Eje dentado	Eje nervado	Eje poligonal P3	Eje poligonal PC4
W_b	$\approx 0,1d^3$	$\approx 0,1D^3$	$\approx \frac{D^3}{10} - \frac{dD^3}{6}$	$\approx 0,1 \left(\frac{D+d}{2}\right)^3$	$\approx 0,1 \left(\frac{D+d}{2}\right)^3$	$\approx 0,1 \frac{D_m^4}{D_s}$	$\approx 0,15 D_1^3$
W_t	$\approx 0,2d^3$	$\approx 0,2d^3$	$\approx 2W_b$	$\approx 0,2 \left(\frac{D+d}{2}\right)^3$	$\approx 0,2 \left(\frac{D+d}{2}\right)^3$	$\approx 0,2 D_1^3$	$\approx 0,2 D_1^3$
I_b	$\approx 0,05 d^4$	$\approx 0,05 D^4$	$\approx \frac{D^4}{20} - \frac{dD^4}{12}$	$\approx 0,05 \left(\frac{D+d}{2}\right)^4$	$\approx 0,05 \left(\frac{D+d}{2}\right)^4$	$\approx 0,05 D_m^4 - 1,2 D_m^3 e^3$	$\approx 0,075 D_1^4$
I_t	$\approx 0,1 d^4$	$\approx 0,1 d^4$	$\approx 2 I_b$	$\approx 0,1 \left(\frac{D+d}{2}\right)^4$	$\approx 0,1 \left(\frac{D+d}{2}\right)^4$	$\approx 0,1 D_m^4 - 2,4 D_m^3 e^3$	$\approx 0,14 D_1^4$

$$\text{Solution: } \sigma_v = \sqrt{52,31^2 + 3 \cdot 32,77^2} = 77,19 \text{ N/mm}^2$$

$$8. \sigma_{adm} \geq \sigma_v \rightarrow 175,19 \geq 77,19 \rightarrow OK$$

1.5 Calculations in Excel at point B

Rolling bearing B		Calculation driveshaft
		$\sigma_{adm} \geq \sigma_v$
		Fatigue resistance
		$\sigma_{adm} = \frac{\sigma_G}{C_s}$
		$\sigma_G = \frac{\sigma_w * b_o}{\beta k b * (1 - R)} \leq k * \sigma_w$
I		
σ_B (steel stress)	450,00	N/mm ²
σ_w (taula 73)	210,00	N/mm ²
ρ^* (taula 73)	0,09	mm
b_o (figura 189)	0,88	Surface finish.

d	20,00	Assumption (mm)
α_{kb} (figura 190)	2,00	Grafico (ρ/t)
d/D	0,80	mm
D	25,00	mm
ρ (rounding r)	2,00	mm
t (profundity)	4,00	mm
ρ/t (figura 190)	0,50	
X (torque + unfavorable)	0,600	mm ⁻¹

$$X = \frac{2}{d} + \frac{1}{\rho}$$

II	
$\beta k b$	1,62
	mm

$$\beta k b = \frac{\alpha k b}{1 + \sqrt{(\rho^* * X)}} \quad R = \frac{\sigma_m}{\sigma_o} \quad \sigma_G = \frac{\sigma_w * b_o}{\beta k b * (1 - R)} \leq k * \sigma_w$$

III		
R	0,50	pulsatory
σ_G	227,74	N/mm ²

$$i \quad \sigma_v = \sqrt{\sigma_o^2 + (3\alpha\sigma^2) * \tau^2}$$

k= (flexion) 2,10

TABLE 73. Resistencia a la fatiga por tracción y compresión σ_u y radio r^* , de las entalladuras equivalentes en materiales tenaces (acero)

σ_u N/mm ²	300	350	400	450	500	600	700	800	900	1000	1100	1200	1300
σ_w N/mm ²	140	170	190	210	230	270	320	360	410	450	500	550	600
r^* mm	0,2	0,25	0,32	0,39	0,46	0,56	0,64	0,73	0,83	0,92	1,02	1,12	1,21



FIGURA 190 Coeficientes de forma de la entalladura α_{kb} de ejes con escalones.

$$\sigma_{adm} = \frac{\sigma_G}{C_s}$$

σ_{adm}	175,19	N/mm ²
C_s	1,30	

	IV	
σ_v	77,19	N/mm ²
Mb (bending moment)	41848,75	N*mm
wb (smooth shaft) (T.71)	800,00	mm ³
σ_o	52,31	N/mm ²
α_o (bending/torque = type load) (pulsatory)	1,00	
τ	32,77	N/mm ²
Mt (torque moment + unfavorable)	52433,00	N*mm
wt (taula 71)	1600,00	mm ³

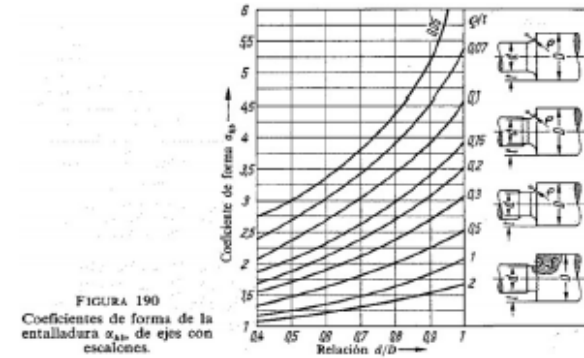
$\sigma_{adm} \geq \sigma_v$

$$\sigma_o = \frac{Mb}{wb} + \frac{N}{\frac{\pi d^2}{4}}$$

$$Mb = \sqrt{My^2 + Mz^2}$$

$$My = 39,33 \quad N*mm$$

$$Mz = 14,31 \quad N*mm$$

$$My = 39325,00 \quad N*mm$$

$$Mz = 14313,00 \quad N*mm$$

$$wb = 0,1 * d^3$$

$$\tau = \frac{Mt}{wt}$$

$$wt = 0,2 * d^3$$

Tabla 71. Momentos de resistencia W_x y W_y contra flexión y torsión, así como momentos de inercia I_x y I_y en distintas secciones de ejes

	Eje liso	Eje ranurado	Eje con orificio transversal	Eje dentado	Eje acorvado	Eje poligonal PS	Eje poligonal PCL
W_x	$\approx 0,1d^3$	$\approx 0,1D^3$	$\approx \frac{D^3}{10} - \frac{dD^2}{8}$	$\approx 0,1 \left(\frac{D+d}{2}\right)^3$	$\approx 0,1 \left(\frac{D+d}{2}\right)^3$	$\approx 0,1 \frac{D_x^3}{D_x}$	$\approx 0,15 D^3$
W_y	$\approx 0,2d^3$	$\approx 0,2D^3$	$\approx 2W_x$	$\approx 0,2 \left(\frac{D+d}{2}\right)^3$	$\approx 0,2 \left(\frac{D+d}{2}\right)^3$	$\approx 0,2 D_y^3$	$\approx 0,2D^3$
I_x	$\approx 0,05d^4$	$\approx 0,05D^4$	$\approx \frac{D^4}{10} - \frac{dD^3}{12}$	$\approx 0,05 \left(\frac{D+d}{2}\right)^4$	$\approx 0,05 \left(\frac{D+d}{2}\right)^4$	$\approx 0,05 D_x^4 - 1,2 D_x^3 e^2$	$\approx 0,075 D^4$
I_y	$\approx 0,1d^4$	$\approx 0,1D^4$	$\approx 2I_x$	$\approx 0,1 \left(\frac{D+d}{2}\right)^4$	$\approx 0,1 \left(\frac{D+d}{2}\right)^4$	$\approx 0,1 D_y^4 - 5,4 D_y^3 e^2$	$\approx 0,14D^4$

1.6 Dimensioning the diameter of the driveshaft at point C.

1. Table 21. $\sigma_B = 450 \frac{N}{mm^2} \rightarrow \sigma_W = 210 \frac{N}{mm^2} \rightarrow \rho^* = 0,09 \text{ mm}$

Table 23. Resistance fatigue

TABLA 73. Resistencia a la fatiga por tracción y compresión σ_w y radio e^* , de las entalladuras equivalentes en materiales tenaces (acero)

$\sigma_B \text{ N/mm}^2$	300	350	400	450	500	600	700	800	900	1000	1100	1200	1300
$\sigma_w \text{ N/mm}^2$	140	170	190	210	230	270	320	360	410	450	500	550	600
$e^* \text{ mm}$	0,2	0,15	0,12	0,09	0,08	0,06	0,04	0,03	0,025	0,02	0,02	0,015	0,01

2. Figure 60. $\sigma_B = 450 \text{ N/mm}^2 \rightarrow b_0 = 0,88$

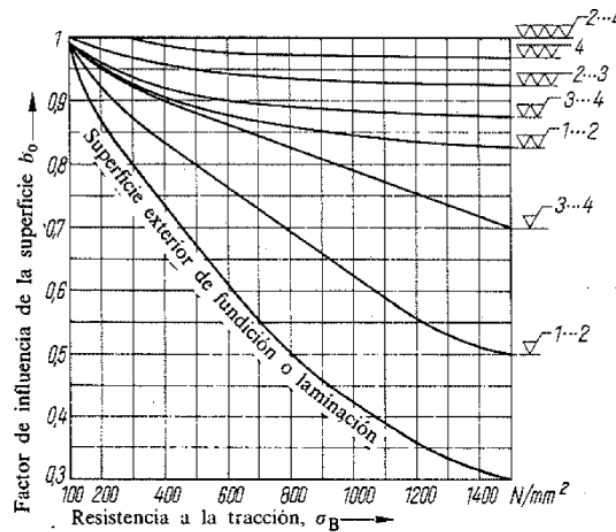

Figure 55. Influence factor b_0 in the relation with the fatigue resistance

3. Considering $d = 40 \text{ mm}$ and with the figure 59.



FIGURA 190
Coeficientes de forma de la entalladura α_{fb} , de ejes con escalones.

Figure 56. Coefficient α_0

α_{kb} :

$$\frac{d}{D} = 0,8 \rightarrow D = 50 \text{ mm}; \rho = 2 \text{ mm}; t = 4 \text{ mm} \rightarrow \frac{\rho}{t} = 0,5 \rightarrow \alpha_{kb} = 2$$

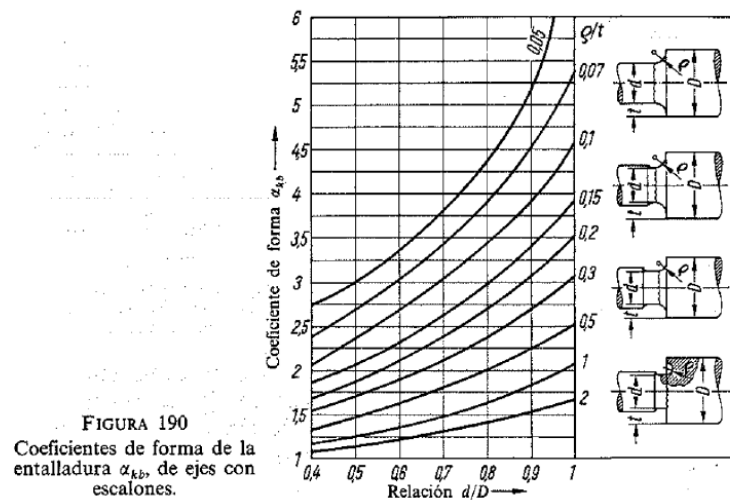
χ :

Considering torque, more unfavorable:

$$\chi = \frac{2}{40} + \frac{1}{2} = 0,55 \text{ (considering the torque equation)}$$

$$4. \beta_{xb}: \quad \beta_{xb} = \frac{\alpha_{kb}}{1 + \sqrt{\rho \cdot \chi}} = \frac{2}{1 + \sqrt{0,09 \cdot 0,55}} = 1,64 \text{ mm}$$

$$5. R = \frac{\sigma_m}{\sigma_0}. \text{ Considering } R = 0,5 \text{ (Pulsatory moments)}$$

6. σ_G :

$$\sigma_G = \frac{210 \cdot 0,88}{1,64 \cdot (1 - 0,5)} = 225,92 \frac{\text{N}}{\text{mm}^2} \rightarrow \sigma_{adm} = \frac{\sigma_G}{C_S}; C_S = 1,3$$

$$\sigma_{adm} = \frac{225,92}{1,3} = 173,78 \text{ N/mm}^2$$

$$\sigma_v = \sqrt{\sigma_0^2 + (3\alpha_0^2)\tau_t^2}$$

$$7. M_c = \sqrt{(M_c)_y^2 + (M_c)_z^2} = \sqrt{24,58^2 + 723,94^2} = 724,36 \text{ N} \cdot \text{m}$$

$$\sigma_0 = \frac{M_c}{W_c} + \frac{N}{\frac{\pi d^2}{4}} = \frac{724,36 \cdot 10^3}{6400} + \frac{0}{\frac{\pi \cdot 47^2}{4}} = 113,18 \text{ N/mm}^2$$

$3\alpha_0^2$: (Considering pulsatory torque and bending): $\alpha_0 = 1$







$$\tau_t = \frac{M_t}{W_t} \rightarrow \tau_t = \frac{52,43 \cdot 10^3}{12800} = 4,1 \text{ N/mm}^2$$

$$W_c = 0,1 \cdot d^3 = 6400 \text{ mm}^3$$

$$W_t \rightarrow \text{table 22} \rightarrow W_t = 0,2 \cdot d^3 \rightarrow 0,2 \cdot 40^3 = 12800 \text{ mm}^3$$

Table 24. Types of shaft

TABLA 71. Momentos de resistencia W_b y W_t contra flexión y torsión, así como momentos de inercia I_b y I_t en distintas secciones de ejes

							
	Ejes lisos	Eje ranurado	Eje con orificio transversal	Eje dentado	Eje nervado	Eje poligonal P3	Ejepoligonal PC4
W_b	$\approx 0,1d^3$	$\approx 0,1D^3$	$\approx \frac{D^3}{10} - \frac{dD^2}{6}$	$\approx 0,1 \left(\frac{D+d}{2}\right)^3$	$\approx 0,1 \left(\frac{D+d}{2}\right)^3$	$\approx 0,1 \frac{D_m^3}{D_s}$	$\approx 0,15 D^3$
W_t	$\approx 0,2d^3$	$\approx 0,2d^3$	$\approx 2W_b$	$\approx 0,2 \left(\frac{D+d}{2}\right)^3$	$\approx 0,2 \left(\frac{D+d}{2}\right)^3$	$\approx 0,2 D^3$	$\approx 0,2 D^3$
I_b	$\approx 0,05d^4$	$\approx 0,05D^4$	$\approx \frac{D^4}{20} - \frac{dD^3}{12}$	$\approx 0,05 \left(\frac{D+d}{2}\right)^4$	$\approx 0,05 \left(\frac{D+d}{2}\right)^4$	$\approx 0,05 D_m^4 - 1,2 D_m^3 e^2$	$\approx 0,075 D^4$
I_t	$\approx 0,1d^4$	$\approx 0,1d^4$	$\approx 2I_b$	$\approx 0,1 \left(\frac{D+d}{2}\right)^4$	$\approx 0,1 \left(\frac{D+d}{2}\right)^4$	$\approx 0,1 D_m^4 - 2,4 D_m^3 e^2$	$\approx 0,14 D^4$

$$\text{Solution: } \sigma_v = \sqrt{113,18^2 + 3 \cdot 4,1^2} = 113,4 \text{ N/mm}^2$$

$$8. \sigma_{adm} \geq \sigma_G \rightarrow 173,78 \geq 113,4 \rightarrow OK$$

1.7 Calculations in Excel at point C

Roller clutch C		
Calculation driveshaft		
$\sigma_{adm} \geq \sigma_v$		
Fatigue resistance		
I		
σ_B (steel stress)	450,00	N/mm ²
σ_w (taula 73)	210,00	N/mm ²
ρ^* (taula 73)	0,09	mm
b_o (figura 189)	0,88	Acatat superf.

$$\sigma_{adm} = \frac{\sigma_G}{C_s}$$

$$i \quad \sigma_v = \sqrt{\sigma_o^2 + (3\alpha\sigma^2) * \tau^2}$$

$$\sigma_G = \frac{\sigma_w * b_o}{\beta k b * (1 - R)} \leq k * \sigma_w$$

$$k = (\text{flexion}) \quad 2,10$$

d	40,00	suposem (mm)
$\alpha k b$ (figura 190)	2,00	Grafico (ρ/t)
d/D	0,80	mm
D	50,00	mm
ρ (rounding r)	2,00	mm
t (profundity)	4,00	mm
ρ/t (figura 190)	0,50	
X (torque + unfavorable)	0,550	mm ⁻¹

$$X = \frac{2}{d} + \frac{1}{\rho}$$

II		
$\beta k b$	1,64	mm

$$\beta k b = \frac{\alpha k b}{1 + \sqrt{(\rho^* * X)}}$$

$$R = \frac{\sigma_m}{\sigma_o}$$

$$\sigma_G = \frac{\sigma_w * b_o}{\beta k b * (1 - R)} \leq k * \sigma_w$$

$$\sigma_{adm} = \frac{\sigma_G}{C_s}$$

III		
R	0,50	pulsatory
σ_G	225,92	N/mm ²

σ_{adm}	173,78	N/mm ²
C_s	1,30	

Tabla 75. Resistencia a la fatiga por tracción y compresión σ_a y radio ρ^* , de las entalladuras equivalentes en materiales tenaces (acero)

σ_a N/mm ²	300	350	400	450	500	600	700	800	900	1000	1100	1200	1300
σ_w N/mm ²	140	170	190	210	230	270	320	360	410	450	500	550	600
ρ^* mm	0,2	0,15	0,12	0,09	0,08	0,06	0,04	0,03	0,025	0,02	0,02	0,015	0,01

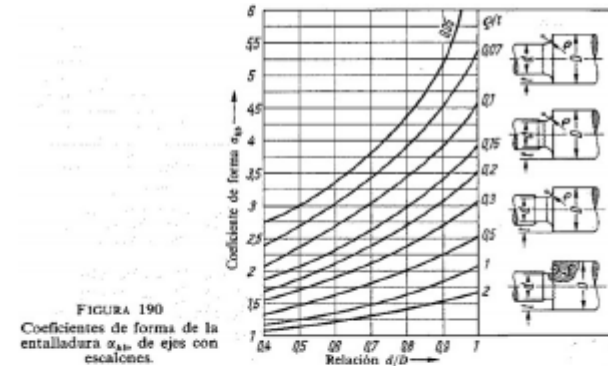

	IV	
σ_v	113,40	N/mm ²
Mc (bending moment)	724353,17	N*mm
wc (smooth shaft) (T.71)	6400,00	mm ³
σ_o	113,18	N/mm ²
α (bending/torque = type load) (pulsatory)	1,00	
τ	4,10	N/mm ²
Mt (torque moment + unfavorable)	52433,00	N*mm
wt (taula 71)	12800,00	mm ³

$\sigma_{adm} \geq \sigma_v$

$$\sigma_o = \frac{Mb}{wb} + \frac{N}{\frac{\pi d^2}{4}}$$

$$Mc = \sqrt{My^2 + Mz^2}$$

My 24,58 N*m
 Mz 723,94 N*m

My 24580,00 N*mm
 Mz 723936,00 N*mm

$$wc = 0,1 * d^3$$

$$\tau = \frac{Mt}{wt}$$

$$wt = 0,2 * d^3$$

Tabla 71. Momentos de resistencia W_b y W_t , contra flexión y torsión, así como momentos de inercia I_b y I_t , en distintas secciones de ejes

	Eje liso	Eje ranurado	Eje con rancho transversal	Eje ranurado	Eje ranurado	Eje ranurado	Eje ranurado
W_b	$\approx 0,1D^3$	$\approx 0,1D^3$	$\approx \frac{D^3 - dD^3}{8}$	$\approx 0,1 \left(\frac{D+d}{2}\right)^3$	$\approx 0,1 \left(\frac{D+d}{2}\right)^3$	$\approx 0,1 \frac{D^3}{D_c}$	$\approx 0,15 D^3$
W_t	$\approx 0,2D^3$	$\approx 0,2D^3$	$\approx 2 W_b$	$\approx 0,2 \left(\frac{D+d}{2}\right)^3$	$\approx 0,2 \left(\frac{D+d}{2}\right)^3$	$\approx 0,2 D_c^3$	$\approx 0,3D^3$
I_b	$\approx 0,06D^4$	$\approx 0,06D^4$	$\approx \frac{D^4 - dD^4}{32}$	$\approx 0,06 \left(\frac{D+d}{2}\right)^4$	$\approx 0,06 \left(\frac{D+d}{2}\right)^4$	$\approx 0,06 D_c^4 = 1,8D_c^4$	$\approx 0,05 D^4$
I_t	$\approx 0,14D^4$	$\approx 0,14D^4$	$\approx 2 I_b$	$\approx 0,1 \left(\frac{D+d}{2}\right)^4$	$\approx 0,1 \left(\frac{D+d}{2}\right)^4$	$\approx 0,1 D_c^4 = 3,4D_c^4$	$\approx 0,14D^4$

1.8 Materials selected

- **Roller bearings**

Cylindrical roller bearing

With the next catalogue, it is chosen the following roller bearings.

<http://www.baleromex.com/catalogos/C-FAG.pdf>

Rodamientos FAG – Catalog WL 41 520/3 SB

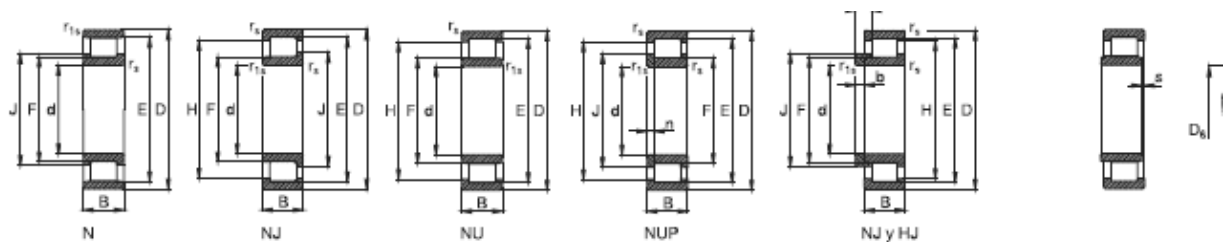

Eje	Dimensiones													Peso		Capacidad de carga	
	d	D	B	r _s min	r _{s1} min	E	F	H	J	n	a	b	s ¹⁾	Roda- miento	Anillo angular	C	estát. C ₂
	mm													kg		kN	
	40	68	15	1	0,6	61	47	58,2					2,7	0,23		29	32
	40	80	18	1,1	1,1	71,5	49,5		54				1	0,358		53	53
	40	80	18	1,1	1,1	71,5	49,5	68,3	54	8,5	5		1	0,389	0,05	53	53
	40	80	18	1,1	1,1	71,5	49,5	68,3					1	0,379		53	53
	40	80	18	1,1	1,1	71,5	49,5	68,3	54,1	3,5				0,399		53	53

¹⁾ Desplazabilidad axial desde la posición central.

Bajo demanda tambi

○ **Roller clutch**

Cylindrical roller bearing

With the next catalogue, it is chosen the following roller clutches.

NTN Ball and Roller bearing. CAT.NO. 2202-IX/E

http://www.ntnamericas.com/en/website/documents/brochures-and-literature/catalogs/ntn_2202-ixe.pdf

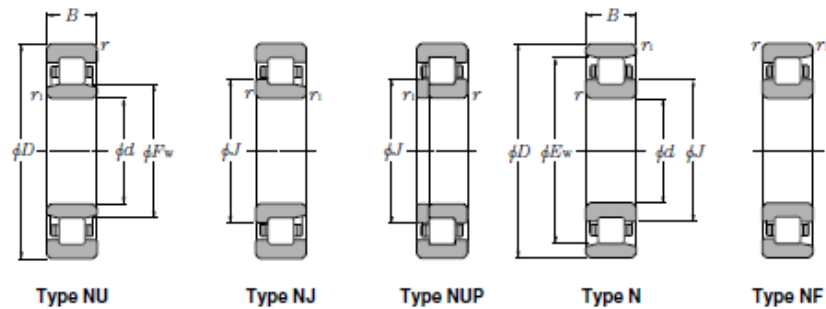

d 45 ~ 60mm

d	Boundary dimensions				Basic load ratings				Limiting speeds ¹⁾		Bearing numbers ²⁾			
	D	B	r ₁ mm ²⁾	r ₂ mm ²⁾	dynamic	static	dynamic	static	grease	oil	type	type	type	type
					C _r	C _{0r}	C _r	C _{0r}						
45	75	16	1	0.6	31.0	34.0	3 200	3 450	9 900	12 000	NU1009	NJ	NUP	N
	85	19	1.1	1.1	48.0	47.0	4 700	4 800	8 400	9 900	NU209	NJ	NUP	N
	85	19	1.1	1.1	63.0	66.5	6 450	6 800	7 600	9 000	NU209E	NJ	NUP	—
	85	23	1.1	1.1	61.5	68.0	6 250	6 900	7 600	9 000	NU2209	NJ	NUP	N
	85	23	1.1	1.1	76.0	84.5	7 750	8 600	6 800	8 000	NU2209E	NJ	NUP	—
	100	25	1.5	1.5	74.0	71.0	7 550	7 250	7 200	8 400	NU309	NJ	NUP	N
	100	25	1.5	1.5	97.5	98.5	9 950	10 000	6 500	7 600	NU309E	NJ	NUP	—
	100	36	1.5	1.5	99.0	104	10 100	10 600	6 300	7 400	NU2309	NJ	NUP	N
	100	36	1.5	1.5	137	153	14 000	15 600	5 700	6 800	NU2309E	NJ	NUP	—
120	29	2	2	107	102	10 900	10 400	5 100	6 000	NU409	NJ	NUP	N	
50	80	16	1	0.6	32.0	36.0	3 300	3 700	8 900	11 000	NU1010	NJ	NUP	N
	90	20	1.1	1.1	48.0	51.0	4 900	5 200	7 600	9 000	NU210	NJ	NUP	N
	90	20	1.1	1.1	66.0	72.0	6 750	7 350	6 900	8 100	NU210E	NJ	NUP	—
	90	23	1.1	1.1	64.0	73.5	6 550	7 500	6 900	8 100	NU2210	NJ	NUP	N
	90	23	1.1	1.1	79.5	91.5	8 100	9 350	6 200	7 300	NU2210E	NJ	NUP	—
	110	27	2	2	87.0	86.0	8 850	8 800	6 500	7 700	NU310	NJ	NUP	N

○ Cogwheel

Spur Gear with hub – Straight tooth

With the next catalogue, it is chosen the following cogwheel.

Metric Spur Gears and Racks. PTI. Module sizes 1-8

https://mdmetric.com/prod/ptic/375_PTI_CATALOG.pdf

Metric Spur Gear with Hub



Module 2.5
20° Pressure Angle
Straight Tooth



Hub Type

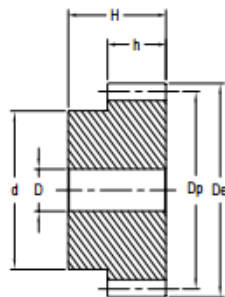
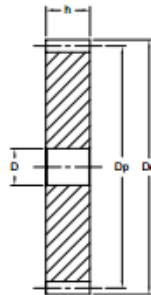

Plate Type



Part No: M2.5B27

M2.5 = Module Size

B = Hub Type or A = Plate Type

27 = Number of Teeth

Material: C45 E Steel

Module	h (mm)	H (mm)
1	15	25
1.5	17	30
2	20	35
2.5	25	40
3	30	50
4	40	60
5	50	75
6	60	80
8	65	95

Teeth	Part No.		Module 2.5						
	Hub Type	Plate Type	De mm	Dp mm	d mm	D mm	Max Torque Nm	Wt. kg	
12	M2.5B12	—	35.0	30.0	22	10	5.9	0.17	
13	M2.5B13	—	37.5	32.5	25	10	6.7	0.21	
14	M2.5B14	—	40.0	35.0	28	10	7.6	0.25	
15	M2.5B15	—	42.5	37.5	30	10	8.3	0.30	
16	M2.5B16	—	45.0	40.0	32	12	8.9	0.33	
17	M2.5B17	—	47.5	42.5	35	12	9.2	0.38	
18	M2.5B18	—	50.0	45.0	35	12	10.4	0.42	
19	M2.5B19	—	52.5	47.5	35	12	11.9	0.45	
20	M2.5B20	—	55.0	50.0	40	14	13.4	0.54	
21	M2.5B21	—	57.5	52.5	40	14	15.1	0.56	
22	M2.5B22	—	60.0	55.0	45	14	16.9	0.66	
23	M2.5B23	—	62.5	57.5	45	14	18.7	0.70	
24	M2.5B24	—	65.0	60.0	45	14	20.8	0.74	
25	M2.5B25	—	67.5	62.5	50	14	22.8	0.85	
26	M2.5B26	—	70.0	65.0	50	14	25.0	0.90	
27	M2.5B27	—	72.5	67.5	50	14	27.3	0.95	
28	M2.5B28	—	75.0	70.0	50	14	29.6	1.00	
29	M2.5B29	—	77.5	72.5	50	14	32.7	1.06	
30	M2.5B30	—	80.0	75.0	55	16	34.9	1.18	
31	M2.5B31	—	82.5	77.5	55	16	37.5	1.22	
32	M2.5B32	—	85.0	80.0	55	16	40.6	1.28	
33	M2.5B33	—	87.5	82.5	55	16	43.8	1.34	
34	M2.5B34	—	90.0	85.0	55	16	46.7	1.41	
35	M2.5B35	—	92.5	87.5	60	16	50.2	1.54	
36	M2.5B36	—	95.0	90.0	60	16	53.3	1.61	
37	M2.5B37	—	97.5	92.5	60	16	54.9	1.68	
38	M2.5B38	—	100.0	95.0	60	16	60.8	1.75	
39	M2.5B39	—	102.5	97.5	60	16	65.3	1.83	
40	M2.5B40	—	105.0	100.0	70	20	71.2	2.06	
41	M2.5B41	—	107.5	102.5	70	20	77.4	2.14	
42	M2.5B42	—	110.0	105.0	70	20	82.2	2.22	
43	M2.5B43	—	112.5	107.5	70	20	92.4	2.30	
44	M2.5B44	—	115.0	110.0	70	20	96.6	2.38	
45	M2.5B45	—	117.5	112.5	70	20	100.0	2.47	
46	M2.5B46	—	120.0	115.0	70	20	107.0	2.52	
47	M2.5B47	—	122.5	117.5	80	20	114.0	2.80	
48	M2.5B48	—	125.0	120.0	80	20	120.0	2.88	
49	M2.5B49	—	127.5	122.5	80	20	128.0	2.98	
50	M2.5B50	—	130.0	125.0	80	20	135.0	3.07	
51	M2.5B51	—	132.5	127.5	80	20	143.0	3.17	
52	M2.5B52	—	135.0	130.0	90	20	149.0	3.48	

53	M2.5B53	—	137.5	132.5	90	20	156.0	3.58
54	M2.5B54	—	140.0	135.0	90	20	165.0	3.68
55	M2.5B55	—	142.5	137.5	90	20	173.0	3.78
56	M2.5B56	—	145.0	140.0	100	20	181.0	4.13
57	M2.5B57	—	147.5	142.5	100	20	190.0	4.23
58	M2.5B58	—	150.0	145.0	100	20	199.0	4.34
59	M2.5B59	—	152.5	147.5	100	20	208.0	4.46
60	M2.5B60	—	155.0	150.0	100	20	217.0	4.57
62	M2.5B62	—	160.0	155.0	100	20	240.0	4.59
63	M2.5B63	—	162.5	157.5	100	20	260.0	4.60
65	M2.5B65	M2.5A65	167.5	162.5	100	20	286.0	3.99
67	M2.5B67	—	172.5	167.5	100	20	295.0	4.61
70	M2.5B70	M2.5A70	180.0	175.0	100	20	324.0	4.64
72	—	M2.5A72	185.0	180.0	—	20	332.0	4.91
75	—	M2.5A75	192.5	187.5	—	20	338.0	5.33
76	—	M2.5A76	195.0	190.0	—	20	340.0	5.48
80	—	M2.5A80	205.0	200.0	—	25	342.0	6.04
85	—	M2.5A85	217.5	212.5	—	25	346.0	6.84
90	—	M2.5A90	230.0	225.0	—	25	348.0	7.68

- **Alternator**

Harmonic alternator / Monophasic / Industrial / Lighting application.

With the next catalogue, it is chosen the following alternator.

Fujian Mindong Electric Co., Ltd.

<http://www.directindustry.es/prod/fujian-mindong-electric-co-ltd/product-126201-1571100.html>



Alternador de armónico / monofásico
/ industrial / para aplicaciones de
iluminación
ST series
Potencia [kW] ◀▶ 2 kW - 50 kW



Appendix 2

2.1 Materials selected

- *AC Dynamo generator 6V-3W*

With the next catalogue, it is chosen the following dynamo for the circuit designed.

http://www.bumm.de/fileadmin/user_upload/Katalog/B_M__Catalogue_2014_15__English.pdf



Then, the estimated prize is chosen through the amazon company:

<http://www.amazon.co.uk/BUSCH-MÜLLER-Dymotec-6-Dynamo/dp/B00F8HWZEE>

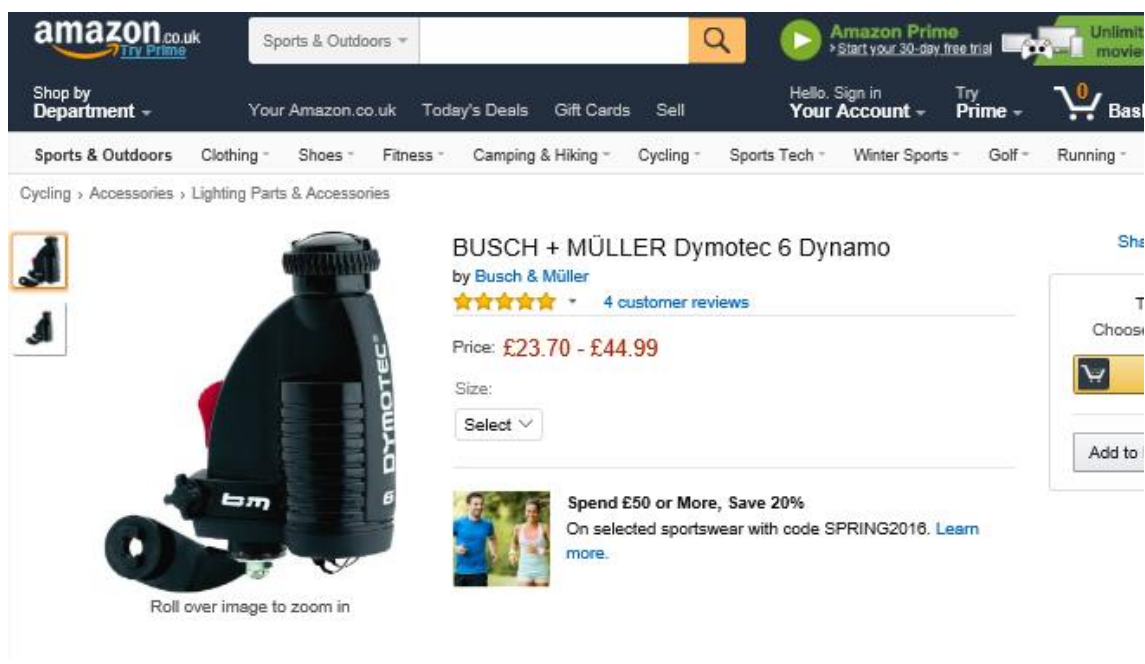

Date. 16/04/2016

○ LED bulb

With the next catalogue, it is chosen the following LED bulb for the 2nd circuit designed.

http://www.gelighting.com/LightingWeb/apac/images/LED-LED-ctlg-EN-052012-PG47-APAC_tcm281-33329.pdf

Low Voltage MR16

The new LED MR16 from GE consumes just 6.5W/7W, produces virtually the same light output of a 35W/50W halogen bulb. With high quality of LED technology, it provides with environmental friendly solutions. And its standard IEC size makes it easy to install.



Application

To create an elegant atmosphere at very low energy costs (compared to halogen or incandescent lamps):

- Hotels
- Restaurants
- Cafes
- Household



Product Features

- Efficient lighting, 6.5W LED MR16 fully replace 35W HAL, 7W LED MR16 fully replace 50W HAL
- 80% energy saving compared with HAL MR16
- Less replacement to save maintenance cost
- Standard IEC size, standard lamp holder, compatible with electronic transformer
- Dimmable

Technical Specifications

- Average life: 25,000hrs
- Multiple color temperature: 2700K/3000K/4000K
- Color rendering index: 80

Dimensions

Unit: mm

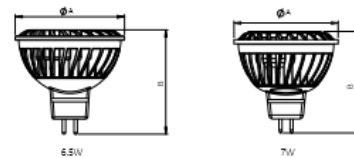

Ordering Description

6.5W

SKU	SKU Description	Input Voltage (V)	Wattage (W)	Initial Lumens (Lm)	Color	CBCP (cd)	Beam Angle (°)	CCT	CRI	L70 Life (hrs)
66820	LED6.5/MR16/827/24D CN	12 VAC/VDC	6.5	320	Silver	1600	24	2700K	80	25000
66821	LED6.5/MR16/830/24D CN	12 VAC/VDC	6.5	320	Silver	1600	24	3000K	80	25000
66822	LED6.5/MR16/840/24D CN	12 VAC/VDC	6.5	320	Silver	1600	24	4000K	80	25000
66823	LED6.5/MR16/827/12D CN	12 VAC/VDC	6.5	320	Silver	3200	12	2700K	80	25000
66824	LED6.5/MR16/830/12D CN	12 VAC/VDC	6.5	320	Silver	3200	12	3000K	80	25000
66825	LED6.5/MR16/840/12D CN	12 VAC/VDC	6.5	320	Silver	3200	12	4000K	80	25000

7W

SKU	SKU Description	Input Voltage (V)	Wattage (W)	Initial Lumens (Lm)	Color	CBCP (cd)	Beam Angle (°)	CCT	CRI	Power Factor	L70 Life (hrs)	
		12VAC	12VDC									
35W Equiv												
66842	LED7DMR16/827/15	12 VAC/VDC	7	370	Silver	3500	15	2700K	80	0.7	1	25000
66843	LED7DMR16/827/25	12 VAC/VDC	7	370	Silver	1800	25	2700K	80	0.7	1	25000
66844	LED7DMR16/827/35	12 VAC/VDC	7	370	Silver	1000	35	2700K	80	0.7	1	25000
66845	LED7DMR16/830/15	12 VAC/VDC	7	390	Silver	3700	15	3000K	80	0.7	1	25000
66846	LED7DMR16/830/25	12 VAC/VDC	7	390	Silver	1900	25	3000K	80	0.7	1	25000
66847	LED7DMR16/830/35	12 VAC/VDC	7	390	Silver	1100	35	3000K	80	0.7	1	25000
66848	LED7DMR16/840/15	12 VAC/VDC	7	430	Silver	4000	15	4000K	80	0.7	1	25000
66849	LED7DMR16/840/25	12 VAC/VDC	7	430	Silver	2100	25	4000K	80	0.7	1	25000
66850	LED7DMR16/840/35	12 VAC/VDC	7	430	Silver	1200	35	4000K	80	0.7	1	25000
50W Equiv												
67503	LED7XDMR16827/25	12 VAC/VDC	7	440	Silver	2400	25	2700K	80	0.7	1	25000
67504	LED7XDMR16827/35	12 VAC/VDC	7	440	Silver	1400	35	2700K	80	0.7	1	25000
67505	LED7XDMR16830/25	12 VAC/VDC	7	460	Silver	2500	25	3000K	80	0.7	1	25000
67506	LED7XDMR16830/35	12 VAC/VDC	7	460	Silver	1500	35	3000K	80	0.7	1	25000
67507	LED7XDMR16840/25	12 VAC/VDC	7	500	Silver	4100	25	4000K	80	0.7	1	25000
67508	LED7XDMR16840/35	12 VAC/VDC	7	510	Silver	1600	35	4000K	80	0.7	1	25000

7W

SKU	SKU Description	Input Voltage (V)	Wattage (W)	Initial Lumens (Lm)	Color	CBCP (cd)	Beam Angle (°)	CCT	CRI	Power Factor 12VAC	12VDC	L70 Life (hrs)
35W Equv												
66842	LED7DMR16/827/15	12 VAC/VDC	7	370	Silver	3500	15	2700K	80	0.7	1	25000
66843	LED7DMR16/827/25	12 VAC/VDC	7	370	Silver	1800	25	2700K	80	0.7	1	25000
66844	LED7DMR16/827/35	12 VAC/VDC	7	370	Silver	1000	35	2700K	80	0.7	1	25000
66845	LED7DMR16/830/15	12 VAC/VDC	7	390	Silver	3700	15	3000K	80	0.7	1	25000
66846	LED7DMR16/830/25	12 VAC/VDC	7	390	Silver	1900	25	3000K	80	0.7	1	25000
66847	LED7DMR16/830/35	12 VAC/VDC	7	390	Silver	1100	35	3000K	80	0.7	1	25000
66848	LED7DMR16/840/15	12 VAC/VDC	7	430	Silver	4000	15	4000K	80	0.7	1	25000
66849	LED7DMR16/840/25	12 VAC/VDC	7	430	Silver	2100	25	4000K	80	0.7	1	25000
66850	LED7DMR16/840/35	12 VAC/VDC	7	430	Silver	1200	35	4000K	80	0.7	1	25000
50W Equv												
67503	LED7XDMR16827/25	12 VAC/VDC	7	440	Silver	2400	25	2700K	80	0.7	1	25000
67504	LED7XDMR16827/35	12 VAC/VDC	7	440	Silver	1400	35	2700K	80	0.7	1	25000
67505	LED7XDMR16830/25	12 VAC/VDC	7	460	Silver	2500	25	3000K	80	0.7	1	25000
67506	LED7XDMR16830/35	12 VAC/VDC	7	460	Silver	1500	35	3000K	80	0.7	1	25000
67507	LED7XDMR16840/25	12 VAC/VDC	7	510	Silver	2700	25	4000K	80	0.7	1	25000
67508	LED7XDMR16840/35	12 VAC/VDC	7	510	Silver	1600	35	4000K	80	0.7	1	25000

Then, the estimated prize is chosen through the ADL (All Day Light) company:

skus://www.alldaylighting.com/shop/led-light-bulbs/ge-67844-led7dmr1684025/



HOME / SHOP / LED LIGHTING / LED REFLECTOR /
LED MR16

GE 67844
LED7DMR16/840/25

\$32.87

ADD TO CART 1

Categories: LED Lighting, LED MR16, LED Reflector

f t e s

DESCRIPTION

GE 67844 Energy Smart 7W AC/DC 4000K GU5.3 Flood 25D Dimmable 12V AC/DC LED-MR16 Light Bulb

- CRI 84
- Wattage 7W
- Lumens 430
- UL Damp Rated
- Cap-Base GU5.3
- Bulb LED-MR16
- Bulb Finish Silver
- Voltage 12V AC/DC
- Equivalent 35 Watts
- Center Beam 2100-CBCP
- Flood 25D Beam Spread
- MOL 1.88in x DIA 2in
- Rated Avg. Life 25000hrs
- Color Temp 4000K Cool White
- UPC Order Code 043168678445

Date 16/04/2016

○ **Rechargeable battery 8Ah**

With the next catalogue, it is chosen the following battery bulb for the 1st circuit designed.

<http://www.elkproducts.com/product-catalog/elk-1280>

Sealed Lead Acid Battery

ELK-1280

ELK Sealed Lead Acid Batteries are excellent for the following applications with regard to size, Amp hour rating, and proper terminal connections: battery backup (for Access Control Systems, Fire Alarm Systems, and Security Alarm Systems), emergency lights, lighted exit signs, and uninterruptible power supplies.

Information:

[ELK-1280 Data Sheet](#)

[Batteries - MSDS](#)



Specifications:

- Nominal Voltage: 12 Volts
- Rated Capacity: 8 AH (20 hour rate)
- Length: 5.94" (151mm)
- Width: 2.56" (65mm)
- Height: 3.74 (95mm)
- Total Height: 3.98" (101mm)
- Terminals: F1-Faston Tab No. 187

Then, the estimated prize is chosen through the Amazon Company:

<https://www.alldaylighting.com/shop/led-light-bulbs/ge-67844-led7dmr1684025/>

12VOLT 8AMP HOUR RECHARGEABLE SEALED BACKUP ALARM TOYS LIGHTS 12V
8AH BATTERY

by Universal Power Group

★★★★☆ 28 customer reviews | 5 answered questions

List Price: ~~\$39.99~~

Price: **\$18.99 & FREE Shipping**

You Save: **\$21.00 (53%)**

In Stock.

Estimated Delivery Date: April 22 - 27 when you choose Expedited at checkout.

Ships from and sold by [Ace Comp Solutions](#).

- High Capacity SLA Batteries
- Voltage: 12V (12 Volts)
- Capacity: 8Ah
- Battery Life 3-5 Years Under Normal Conditions
- 1 Year Warranty

5 new from **\$18.99**

Date (16/04/2016)

○ **Rechargeable battery 5Ah**

With the next catalogue, it is chosen the following battery bulb for the 2nd circuit designed.

<http://www.communica.co.za/catalog/Details/P2647837992>

Catalog > Consumer Electronics > Batteries and Battery Accessories > Lead Acid Rechargeable



BATT 12V5
Battery

12V 5AH Lead-Acid Rechargeable Battery • L=86 W=70 H=98mm

Part No: **BATT 12V5**

162.45 ZAR
inc
for 1 Each

Note : Specifications, Prices & Availability may change without notice. Images are for illustration purposes only. E&OE

Additional Information

Electrochemical System	Lead-Acid
Nominal Voltage	12V
Nominal Capacity	5AH
Size	L=86 W=70 H=98mm
Rechargeable	True

Then, the estimated prize is chosen through the Amazon Company:

<http://www.amazon.com/12V-5AH-SLA-187-FASTON/dp/B000BPCUXO>



12V 5AH SLA 187 FASTON
by Interstate Batteries

★★★★☆ 299 customer reviews | 26 answered questions

Price: **\$19.79** & FREE Shipping

In Stock.

Estimated Delivery Date: April 26 - 29 when you choose Standard at checkout.
Ships from and sold by Batterysharks.

- Not Used



4 new from \$19.79 1 refurbished from \$20.00

Date (16/04/2016)

- **Book converter, input voltage 12-14V, output voltage 5V**

With the next catalogue, it is chosen the following book converter for the 1st or 2nd circuit designed.

<http://www.powerstream.com/dcdc-12V.htm>

3.3 to 38V output		12V input (2.9V to 36V) boost converter	Boost DC converter increases the input voltage including such ratios as 12V to 24V or 12/19V	This convenient module increases the input voltage over the range 2.9V to 38V with up to 95% efficiency. Output power is 12W to 25W depending on input/output voltage ratio.
Adjustable 1.5V to 11.4V out with 12V in		12V (6V-32V) in	Adjustable step-down or buck converter 3A continuous	Weather resistant DC converter potted module with flying leads in/out
Adjustable from 0.025V to near input voltage	 PST-DCCP	12V (3V-32V)	Constant current buck converter 3.5A continuous, 5A peak	Suitable for constant voltage or constant current applications, including battery charging, supercapacitor charging, electromagnet control and filament power.

PST-DCCP	Specifications
Input voltage:	3V to 36V input
Output user adjustable:	0.025V to 36V output (input voltage must be at least 0.5V higher than output)
Peak output current:	Up to 5 Amps, current limit is user-adjustable
Continuous output current	3.5 Amps
Isolation	Non-isolated, common ground. To operate in constant current mode both the positive and the negative output wires must be used
Adjustment method	Pots accessible on the top of the unit. The pot labeled W103 adjusts the output voltage limit. The pot labeled W102 adjusts the output current limit.
Efficiency	Up to 96% efficient with 5V or higher output, up to 87% with 3.3V output
Form	Potted module with flying leads

Then, the estimated prize is chosen through the PowerStream products:

<http://www.powerstream.com/Product3.htm>

PST-DCCP constant current DC/DC step-down converter	
Quantity	1 - 9 10 - 99 100 - 999 1000+
Price	\$24.95 \$22.70 \$19.90 \$16.25
Add to Cart	
PST-DCCP-XX-YY factory adjusted constant current DC/DC step-down converter specify output voltage and output current settings	
Quantity	1 - 9 10 - 99 100 - 999 1000+
Price	\$29.95 \$26.70 \$22.90 \$19.75
Add to Cart	
Optional barrel socket to screw terminal adapter	\$2.50 Add to Cart
	

Date (16/04/2016)

- **Boost converter, input voltage 1V-10V, output voltage 12V-14V**

With the next catalogue, it is chosen the following boost converter for the 1st or 2nd circuit designed.

<http://www.ti.com/tool/tps6734evm#descriptionArea>

TPS6734I
FIXED 12-V 120-mA BOOST-CONVERTER SUPPLY

SLVS127A – AUGUST 1995 – REVISED JANUARY 1999

- Pin-for-Pin Compatible With MAX734
- Programming Voltage for Flash Memory
- 2.7-V to 11-V Input Operating Range
- Output Current of 120 mA or Greater From 3.75-V or Higher Input
- 3- μ A Maximum Supply Current in Shutdown
- Only 5 External Components Required
- High Efficiency . . . 85% Typical (5-V Input, 120-mA Output)
- 8-Pin SOIC and DIP Packages
- -40°C to 85°C Free-Air Operating Temperature Range

D OR P PACKAGE
(TOP VIEW)

Then, the estimated prize is chosen through the Amazon products:

http://www.amazon.com/gp/product/B00DWX8PM2/ref=pd_lpo_sbs_dp_ss_2?pf_rd_p=1944687502&pf_rd_s=lpo-top-stripe-1&pf_rd_t=201&pf_rd_i=B00J03PBW0&pf_rd_m=ATVPDKIKX0DER&pf_rd_r=11CNKP9SAPBD436VR1JA

amazon
Try Prime

Electronics

Departments - Your Amazon.com Today's Deals Gift Cards Sell Help

All Electronics Deals Best Sellers TV & Video Audio & Home Theater Computers Camera & Photo Wearable Technology Car Electronics & GPS Portable

Shop by vehicle: Year Make Model Go

Electronics > Accessories & Supplies > Batteries, Chargers & Accessories > Power Converters

DROK® LTC1871 3.5V-30V DC Boost Converter Power Transformer Voltage Regulator 5V/12V Step Up Volt Mod Power Supply Board for Car Auto Motor Motorcycle Automotive etc

by DROK
★★★★☆ 32 customer reviews | 6 answered questions

Price: \$15.95 & FREE Shipping on orders over \$49. Details

In Stock.
Want it tomorrow, April 22? Order within 1 hr 3 mins and choose One-Day Shipping at checkout. Details

Sold by DROK and Fulfilled by Amazon. Gift-wrap available.

Color: Blue

\$15.95 \$15.95

Date (16/04/2016)

- **Rectifier AC-DC, input voltage 1V min, output voltage 12V max**

With the next catalogue, it is chosen the following Rectifier AC-DC for the 1st or 2nd circuit designed. Then, the estimated prize is chosen through the Alibaba products:

http://www.alibaba.com/product-detail/the-best-selling-international-market-AC_60304474644.html?spm=a2700.7724857.29.117.cDEc12



Product Details	Company Profile	Transaction History	Report Suspicious Activity		
Quick Details					
Place of Origin:	Zhejiang, China (Mainla...	Brand Name:	Shangjing	Model Number:	KBPC5010
Type:	Silicon Controlled Rectif...	Application:	Inverter / Converter	Package Type:	Surface Mount
Peak Repetitive Reverse Voltage:	100V-1200V	Peak Non-Repetitive Reverse Voltage:	100V-1200V	Mean On-State Current:	25A
Dimensions:	international standard	item:	rectifier KBPC2510	material of chip:	molybdenum
warranty:	180 days	advantage:	competitive price, reliab...	certificate:	CE RoHS ISO
insulation performance:	good	heat dissipation performance:	good	Vfm:	1.2V
Vrrm:	100V-1200V	Irrm:	<5A		

the best selling international market AC to DC bridge diode rectifier KBPC2510

FOB Price:	US \$0.5 - 3 / Piece Get Latest Price
Min.Order Quantity:	12 Piece/Pieces KBPC2510
Supply Ability:	2000 Piece/Pieces per Week KBPC2510
Port:	Shanghai, Ningbo
Payment Terms:	L/C,T/T,Western Union,MoneyGram

 [Contact Supplier](#)

 [Leave Messages](#)

Date (16/04/2016)