

Jonathan Pearce

# **Research and Development of a 6 Degrees of Freedom Electric Motion Platform**

Fundamentals of a Motion Platform

Bachelor's Thesis  
Autumn 2016  
School of Technology  
Automation Engineering

SEINÄJOKI UNIVERSITY OF APPLIED SCIENCES

## **Thesis abstract**

Faculty: School of Technology

Degree Programme: Automation Technology

Specialisation: Machine Automation

Author: Jonathan Pearce

Title of thesis: Research and Development of a 6 Degrees of Freedom Electric Motion Platform

Supervisor(s): Markku Kärkkäinen

Year: 2016

Number of pages: 34

Number of appendices: 1

---

This thesis was created on account of the Seinäjoki University of Applied Sciences VR Laboratories desire to have a motion platform for their 3D system. We will briefly touch on different types of motion platform, their uses, and a little about the conception of motion platforms. This will be followed by the research and development of some of the core components of the intended motion platform. After which we will delve into how humans sense motion and how this is used to the advantage of motion platforms. Next we will do some rough inverse kinematic calculations for the intended motion platforms. Towards the end of the thesis I will tell of the various different programs I tried to use to model the intended motion platform and some information about the one I used. Finally, I will tell of my attempts at simulating the intended motion platform, its end results and of possible future developments.

Keywords: motion, sense, actuator, kinematics, Nx 10, MCD

SEINÄJOEN AMMATTIKORKEAKOULU

## Opinnäytetyön tiivistelmä

Koulutusyksikkö: Tekniikanyksikkö

Tutkinto-ohjelma: Automaatiotekniikka

Suuntautumisvaihtoehto: Koneautomaatio

Tekijä: Jonathan Pearce

Työn nimi: Kuuden vapausasteen sähköisen liikealustan tutkimus ja tuotekehittely

Ohjaaja: Markku Kärkkäinen

Vuosi: 2016

Sivumäärä: 34

Liitteiden lukumäärä: 1

---

Tämä opinnäytetyö sai alkunsa Seinäjoen ammattikorkeakoulun virtuaalitekniikan laboratorion toiveesta saada liikealusta heidän 3D järjestelmään. Aluksi selvitetään erilaisten liikealustojen rakenteita, niiden käyttöä ja kuinka liikealustat saivat alkunsa. Tämän jälkeen perehdytään osaan luotavan liikealustan komponenttien tutkimiseen ja valitsemiseen. Seuraavana katsotaan kuinka ihminen aistii liikkeen ja kuinka epätäydellisyyksiä aisteissa voidaan käytetään hyväksi liikealustoissa. Sitten on laskettu luotavalle liikealustalle suunnan antavia käänteiskinemaattisia laskutoimituksia. Vielä ennen loppua kerron etsinnöistä löytää ohjelmaa, jolla mallintaa luotava liikealusta ja tietoa ohjelmistosta jota lopulta käytin. Viimeiseksi kerron yrityksistäni simuloida luotavan liikealustan mallia, mahdollisen lisätutkimuksen tarvetta ja loppuyhteenveto.

Asiasanat: liike, aisti, toimielin, kinematiikka, Nx 10, MCD

## TABLE OF CONTENTS

Thesis abstract.....	2
Opinnäytetyön tiivistelmä.....	3
TABLE OF CONTENTS .....	4
Terms and Abbreviations.....	6
Tables, Figures and Pictures .....	8
<b>1 INTRODUCTION .....</b>	<b>9</b>
1.1 Thesis background.....	9
1.2 Objective of the thesis.....	10
1.3 Progression of the Thesis .....	10
<b>2 MOTION PLATFORMS IN GENERAL .....</b>	<b>12</b>
2.1 Types of motion platforms.....	12
2.2 Applications for motion platforms .....	13
2.3 Beginning of motion platforms.....	14
<b>3 LINEAR ACTUATORS .....</b>	<b>16</b>
3.1 Lead screw.....	16
3.2 Ball screw.....	17
3.3 Roller screw .....	18
<b>4 MOTION AND THE SENSES.....</b>	<b>19</b>
4.1 Proprioceptors.....	19
4.2 Vestibular system.....	20
4.3 Visual inputs.....	20
<b>5 REPLICATING MOTION .....</b>	<b>22</b>
5.1 Washout filters .....	22
5.2 Other tactics used .....	23
<b>6 DESIGNING A MODEL MOTION PLATFORM .....</b>	<b>24</b>
6.1 Inverse kinematics .....	24
6.1.1 Platform calculations.....	24
6.1.2 Base calculations.....	25

6.1.3	Rotation Matrix.....	25
6.1.4	Actuator length.....	26
6.2	Modelling.....	26
6.2.1	Searching for a program .....	27
6.2.2	Nx 10 .....	27
6.2.3	Mechatronics Concept Designer (MCD) .....	28
7	SIMULATION .....	30
7.1	Limitations and failure .....	30
7.2	Possible future development.....	30
8	CONCLUSIONS.....	32
	BIBLIOGRAPHY.....	33
	APPENDICES .....	35

## Terms and Abbreviations

<b>3dof</b>	Three degrees of freedom
<b>4D theater</b>	A theater that has a 3D screen and motion simulation on the seats, to try and impart movement to the audience.
<b>6dof</b>	six degrees of freedom
<b>Actuator</b>	A mechanism by which a control system acts upon the environment, typically by introducing motion.
<b>Ball joint</b>	A type of spherical bearing that allows for angular rotation and motion in two directions, limited by geometry.
<b>Delta robot</b>	A type of parallel robot that consists of a manipulator moved by three or more arms connected by universal joints to a base.
<b>Excel</b>	A spread sheet developed by Microsoft, it is used to organize, analyze and store data.
<b>Gimbal</b>	A pivoted support that allows rotation around a certain axis.
<b>Hydraulics</b>	The use of pressurized liquids to transfer power and generate motion.
<b>MCD</b>	Mechatronics Concept Designer, a component of the NX 10 program.
<b>Nx designer</b>	A program that has a lot of different built-in functions, from computer assisted drawing to computational fluid dynamics.
<b>PLC</b>	Programmable Logic Controller is a type of computer used in automation.

<b>Pneumatics</b>	The use of pressurized gases to transfer power and generate motion.
<b>SeAMK</b>	Seinäjoki University of Applied Sciences
<b>Virtual reality</b>	A computer technology that is used to create a realistic environment, often allows the user to interact with it directly.
<b>Washout filter</b>	A filter that is used to manipulate changes in a signal.

## Tables, Figures and Pictures

Table 1, Attachment point on the platform .....	24
Table 2, Attachment point on the base .....	25
Table 3, Rotational matrix equation .....	26
Table 4, Rotational matrix indepth makeup.....	26
Figure 1, Example of a screw type linear actuator assembly (Accuweb online publication 2016).....	16
Figure 2, Deconstruction of a roller screw (Rollvis Swiss web catalog 2016) .....	18
Figure 3, A muscle spindle type proprioceptor (Audible Odessey online publication 2016).....	19
Figure 4, Model of a vestibular system and the rest of the inner ear (PTWebucation online publication 2016) .....	20
Figure 5, The rough model of the motion platform in Nx 10 .....	29
Picture 1, VR lab and the Cave (SeAMK home page 2016) .....	9
Picture 2, Moog 6dof motion platform (Moog internet catalog 2016).....	13
Picture 3, The French Antoinette Simulator 1910 (The National Center for Simulation online article by Kevin Moore) .....	15
Picture 4, Frontier Airlines Airbus A320 simulator (Article by Brian Summers 2015)	14
Picture 5, Example of a lead screw (Roton web catalog 2016).....	17
Picture 6, Cross-section of a ball screw (Rockford Ball Screw web catalog 2016)	17



# 1 INTRODUCTION

## 1.1 Thesis background

Seinäjoki University of Applied Sciences has a very advanced virtual reality laboratory (VR lab), in which there is a 3D experience called the Cave. The VR lab has the capability to study the uses of three-dimensional space, virtual reality and new types of user interfaces. The Cave uses 5 projectors to create a fully immersive experience. The Cave and the VR lab are being constantly improved upon, for example, in recent years a more advanced position tracking system was integrated into the 3D system. A lot of these improvements were made as final theses or special in-house projects. The person in charge of the VR lab, Tapio Hellman, had been interested in adding a motion platform to the Cave and was offering it as a possible final thesis project to anybody interested.

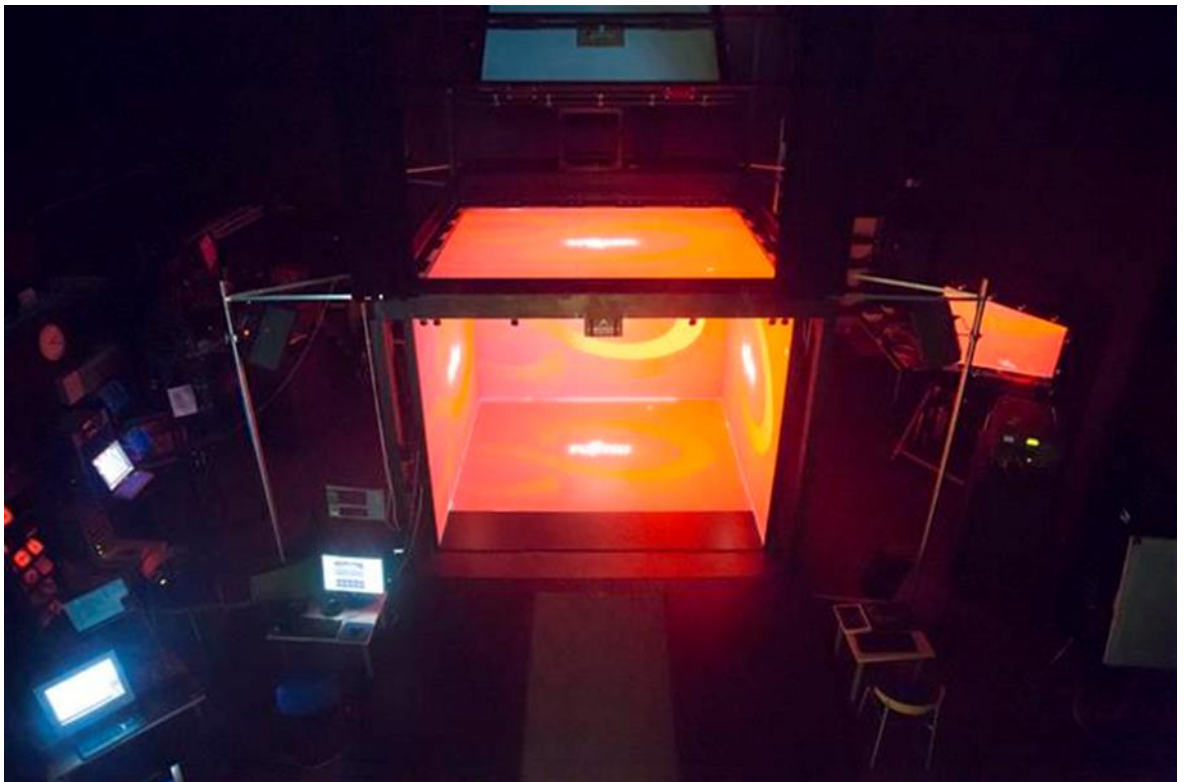

Picture 1, VR lab and the Cave (Seamk home page 2016)

## 1.2 Objective of the thesis

The original goal of the thesis was to create a working prototype motion platform for the VR lab at Seinäjoki University of Applied Sciences. This was however changed during the course of the research to making a working simulation of the motion platform and then simulating it; to learn it's capabilities. Hopefully then someone else might continue and build a prototype and integrate it into the 3D system.

## 1.3 Progression of the Thesis

First I searched for manufacturers of motion platforms and the different ways they can be built. The school had some spare servomotors that could be used in the motion platform, I researched how servomotors are connected to motion platforms and if a gear system was needed. Then I calculated roughly how powerful the servomotors were and whether or not a gear system would be necessary; it was decided not to use one as it negatively affected the motion platform's performance. Due to speed and acceleration being such important factors for a motion platform I began searching for a way to make more accurate calculations. Next we chose what linear actuators to use, I then began searching for places to purchase the actuators and their rough price. Next I investigated the movement restrictions of different motion platforms and how motion platforms affect humans. Following that I contacted a motion platform manufacturer to ask for a quote and some assistance, they were unfortunately unable to help and the price for the system was way over the VR lab's budget. I then began to research how to calculate the kinematics of a motion platform, only to discover that it is very difficult and it is far easier to calculate the inverse kinematics. I made an Excel spread sheet that calculated the lengths of its different legs based on the position of its platform; I hoped to use this to model the system and accurately calculate the capabilities of the motion platform. Due to Excels limitations I was unable to use this to accurately model the system. I then began to search for a program I could use to model the system, eventually, after many failures, the NX designer seemed to be able to do the necessary modelling and simulation. At this time, it was also decided to narrow

down the scope of the thesis from a working prototype to one of a simulated model.

## 2 MOTION PLATFORMS IN GENERAL

A motion platform is used to emulate motion in different simulators and to improve how realistic the simulation is. With proper implementation the added movement can make a huge difference on a person's perception of how real something is. Motion platforms are typically for either recreational or academic use, their use is somewhat limited due to their high price. There are however a fair number of enthusiasts that have made their own motion platforms for home use, this has become more popular as of late and you can find several sites on the internet where people show their creations. Unfortunately, the vast majority of them use different construction methods than what was desired by the school, so they were not of particular help for this thesis.

### 2.1 Types of motion platforms

Motion platforms are divided into several categories based on their degrees of freedom, the actuator used and construction type. The most common systems have two, three or six degrees of freedom, the six degrees of freedom are called heaving (moving up and down), swaying (moving left and right), surging (moving forward and backward), pitching (tilting forward and backward), yawing (turning left and right) and rolling (tilting side to side). Motion platforms use hydraulic, pneumatic or electric actuators, older systems used predominantly hydraulic or pneumatic actuators. Nowadays electric actuators are used more often than hydraulic or pneumatic ones, due to the fact they are less noisy and require little maintenance. Hydraulic actuators are still used in large and heavy systems, pneumatic actuators, on the other hand, are rarely used. Motion platforms that have six degrees of freedom are constructed as Stewart platforms aka hexapods. Stewart platforms consist of a moving platform, a secured base, six ball joints on both the platform and the base and six actuators that connect the platform to the base via the ball joints. For motion platforms with two or three degrees of freedom, a gimbal or simple tilting platform design is commonly used. The School had requested that the motion platform use electric actuators and have six degrees of freedom; so that is what I focused my research on. As a side note it is worth mentioning that

delta robots work on the same principal as a lot of motion platforms, so the Stewart platform design can be used in some interesting applications.



Picture 2, Moog 6dof motion platform (Moog internet catalog 2016)

## 2.2 Applications for motion platforms

When in recreational use motion platforms most often emulate the motion of video games; usually racing games or other vehicle based games. Other notable recreational uses include 4D theatres and rides at amusement parks. In academics' motion platforms are often used to emulate motion in training simulations, these include, but are not limited to, teaching how to drive, fly, operate heavy machinery and training for various situations on cars, boats or planes. Another common use for motion platforms is as a part of tests carried out on vehicle simulations; helping to verify and analyse their performance before construction. A particularly noteworthy application I found while doing research was a motion platform used to simulate the motion of an ambulance, so that medical students can train how to treat patients in a moving ambulance.



Picture 3, Frontier Airlines Airbus A320 simulator (Article by Brian Sumers 2015)

### 2.3 Beginning of motion platforms

Motion platforms or motion simulation in general started out as flight simulators. Originally pilots were trained by progressing through a graded sequence of exercises on real aircrafts. As the need for pilots increased, additional training methods that could be done without an aircraft were developed. One early ground-based trainer was the Sanders Teacher, that was featured in Flight Magazines December issue of 1910. The Sanders Teacher was in essence an aircraft mounted on a universal joint in an exposed position and faced into the prevailing wind. This led to problems as the wind is very unreliable and often irregular, which resulted in this type of flight simulator being unsuccessful. During this time period there was also developed a flight training device that can be considered as one of the first true motion simulators, it was called the Antoinette Simulator. It was constructed from two half-sections of a barrel, mounted and moved manually so as to represent the pitch and roll of an aircraft.



Picture 4, The French Antoinette Simulator 1910 (The National Center for Simulation online article by Kevin Moore)

World War 1 further spurred on the development of new training methods and devices. As technology developed human operators were replaced with actuators, now flight simulators were able to move the fuselage of the simulator such that it corresponds to that of a real aircraft in response to the trainee pilot's control inputs. From this point on flight simulators began to develop into what can be recognized as a modern flight simulator. By the 1960s flight simulators had become an important part of commercial airline pilot training, due to training in a physical aircraft no longer being practical. As a side note without the training provided by simulators it would not have been possible for man to have reached the moon.



### 3 LINEAR ACTUATORS

Linear actuators make linear motion, in the case of most electric linear actuators they take rotational motion and transform it into linear motion. There were several different types of linear actuators to consider for use in the project. The first one I considered was a crank system, however it was not used due to its: high variance, low efficiency and the high strain it placed on the motors. It was decided that we would use a screw type actuator as they are overall far better suited for the intended motion and easy to work with. In screw type actuators the actuator's nut is rotated making the screw shaft move linearly. The main difference between the following screw types is how the nut and the threads of the screw interact and how this effects the properties of the screw. Next there are some advantages and disadvantages of the different screw types, and some reasoning why we chose to use the type of screw that we did.

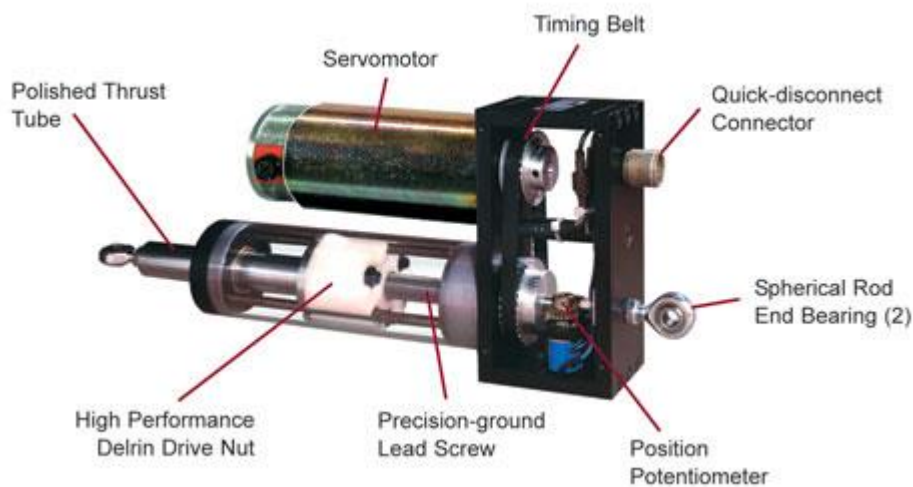

Figure 1, Example of a screw type linear actuator assembly (Accuweb online publication 2016)

#### 3.1 Lead screw

The lead screw also commonly known as the Acme screw in certain parts of the world, is capable of carrying high loads, which is useful when moving people. It is also very compact, reducing the size of the motion platform. They are also easy to design and manufacture, we were even considering the possibility of making one



at the school, but that was ultimately determined to be unfeasible. It has accurate, controllable, even and quiet linear movement that requires little maintenance. Unfortunately, they have poor efficiency and do not lend themselves to continuous use. The grooves in the screw are subjected to a large friction force, which can wear them out very quickly. Their slow speed also does not lend itself to use in a motion platform where high speeds may be necessary.



Picture 5, Example of a lead screw (Roton web catalog 2016)

### 3.2 Ball screw

The ball screw has low friction, good efficiency and a long life span with low maintenance, making it a very versatile screw. The main disadvantages are that the low friction causes the screw to back-peddle when holding up a significant weight and its price is higher than the lead screw. They also tend to be bulkier than lead screws due to the ball return mechanism. However, the ball screw was chosen to be used in the construction of the motion platform, due to it having very good rounded attributes, high efficiency and was in an acceptable price range.



Picture 6, Cross-section of a ball screw (Rockford Ball Screw web catalog 2016)

### 3.3 Roller screw

The roller screw is rather similar to the ball screw, so I will only talk about the major differences between the two. At low and medium speeds, the roller screw has better efficiency, but at higher speeds this is reduced. They are more compact, they are more accurate and can carry higher loads than ball screws. They also have very good acceleration, they are very fast and have a long life span, their main negative point is that they are very expensive.

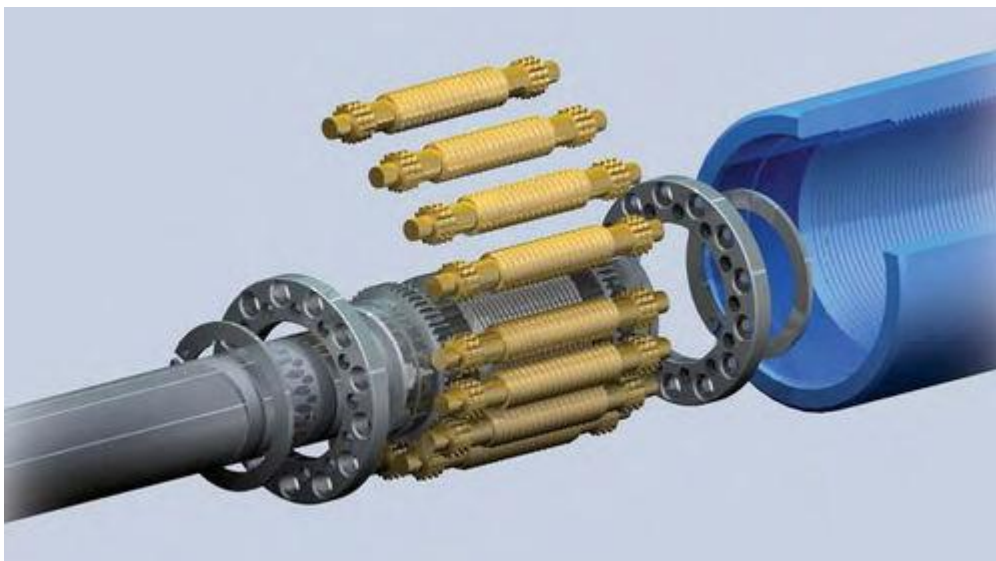

Figure 2, Deconstruction of a roller screw (Rollvis Swiss web catalog 2016)

## 4 MOTION AND THE SENSES

The way humans sense motion is a complex interworking of several systems, these systems are also a major part of what give us our sense of balance. They help us walk and move around and are used to identify our position and orientation in the world. In order to get the best performance out of a motion platform it is important to understand how humans sense motion, and how to trick those senses. The following senses are the core parts of sensing motion and movement and are affected by motion platforms the most.

### 4.1 Proprioceptors

Let us start with proprioceptors that are in muscles, tendons and joints, they help the brain determine the bodies position. For example, if you close your eyes and move your hand the proprioceptors will send signals to your brain, allowing it to figure out how your hand has moved. There are several different types of proprioceptors that detect the movement of different parts of the body. As an example of a proprioceptor, I will mention the muscle spindle that detects the stretching of muscles. For motion platforms proprioceptors tell the brain how your body is being rocked around by the platform, helping to create a sense of greater motion.

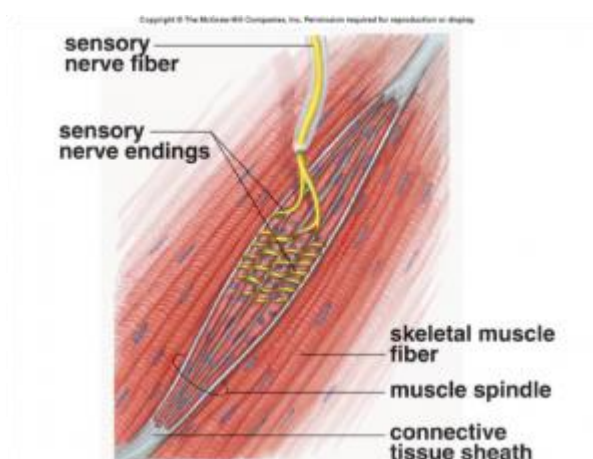

Figure 3, A muscle spindle type proprioceptor (Audible Odessey online publication 2016)

## 4.2 Vestibular system

Next is the vestibular system, which is a primary part of the body's sense of balance and spatial orientation and this in-turn allows a body to move without falling over. The vestibular system consists of three semi-circular canals located in the inner ear, and the otolithic organs. The canals are at approximate right angles to each other, thus allowing the vestibular system to detect motion in those directions. The otolithic organs sense linear acceleration, and consists of two organs called the utricle and the saccule. In order to determine head orientation, the brain compares the signals coming from these organs and other signals, such as: visual inputs and the proprioceptors in the neck. Using this information, the brain can tell whether the head is tilting or the entire body is falling over.

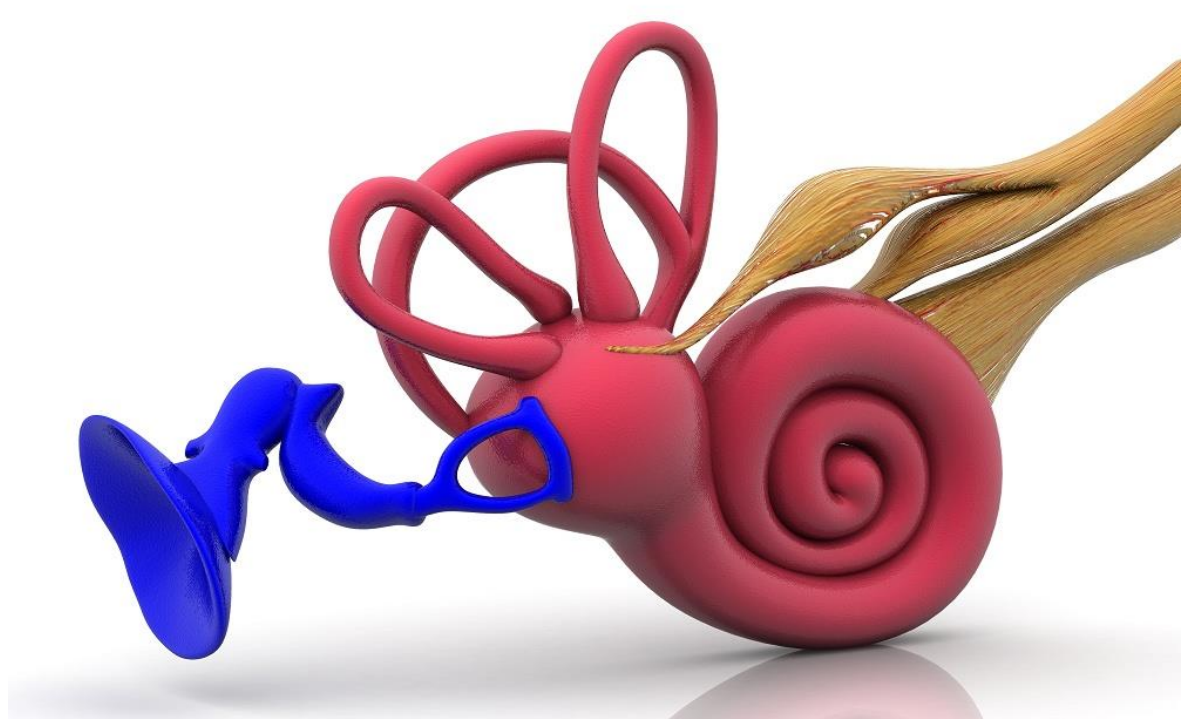

Figure 4, Model of a vestibular system and the rest of the inner ear (PTWebucation online publication 2016)

## 4.3 Visual inputs

Last there are the visual inputs, sight plays a crucial role in discerning movement, position, velocity, your sense of balance and maintaining an upright posture. Sight plays a bigger role in how humans sense motion than the vestibular system or the

proprioceptors. Due to the central nature of visual inputs it is important that motion platforms are in perfect sync with the visual cues shown. If the visual cues shown do not match the motion created by the motion platform it can cause dizziness and nausea.

## 5 REPLICATING MOTION

It is impossible to perfectly replicate motion, thus motion platforms are used to replicate only the most relevant movements for the simulation. This is possible because of two things, first the proprioceptors and the vestibular system send the brain only relative information. Secondly they cannot sense acceleration and velocity perfectly and may experience error. Visual inputs are the main part in how the body figures out its location on an absolute scale. In other words: you show the movement happening and you create relative motion, and this is the beginning of the complex task known as motion simulation.

### 5.1 Washout filters

One important part of simulating motion is washout filters, for example, the motion platform returns to its start position during a continuous motion. It does this with a low speed, so that the proprioceptors and the vestibular system cannot sense the movement. This makes the brain think the movement is continuing, despite the platform returning to the start position, allowing the motion platform to prepare for the next movement. There are several different types of washout filters, the three most common are the classic, adaptive and optimal washout filter. The classic washout filter is in essence a high-pass and low-pass filter working together, the high-pass filter for rotational and transitional movement and the low-pass filter for sustained acceleration. The adaptive washout simulator is the same as the classic one but with a self-tuning feedback mechanism and the optimal washout filter takes into account the vestibular system. Some notable problems with washout filters are that they might not have enough time to move back to the start position before the next movement. This can occur if the motion simulated changes very quickly, for example, in a race car or fighter jet. Another problem is that the washout filter might cause the motion platform to make false motions, for example, motion that is opposite to the expected one or at an unexpected time.

## 5.2 Other tactics used

It is possible to help hide movement by adding jitter and vibration to it, making it harder to notice that the platform is moving and not just shaking. Furthermore, some imperfections in the motion platform can be masked simply by guiding the occupant's attention away from it or distracting them in some other way. On the other hand, rotational movement has no easy work around, so many motion platforms do not use fast and/or large rotational movements. A notable trick I found is when trying to simulate a constant acceleration, it can be substituted with gravity by tilting the occupant backwards.

## 6 DESIGNING A MODEL MOTION PLATFORM

In the case of motion platforms that use a Stewart platform design, their forward kinematics are far more complicated than their inverse kinematics. This is due to the interlocking nature of the actuators; thus causing the system to be very complex and hard to simulate. While I based this motion platform on designs of some I had seen, it is designed from scratch and the dimensions of the parts and the system might not be optimal and may require additional refinement. The simulation of the motion platform should grant a greater understanding of any short comings or problems that might occur.

### 6.1 Inverse kinematics

Next we will go through, in practical terms, the inverse kinematics I used in the excel document to calculate the actuator lengths for a desired position of the platform. These calculations were unfortunately inaccurate and never worked perfectly, but were important in understanding how a motion platform works.

#### 6.1.1 Platform calculations

First I attach a coordinate system to the centre of the base and platform, called  $B_{xyz}$  and  $T_{xyz}$ . Then I calculated the coordinates for the first actuators attachment point on the platform called  $GT_1$ , the separation angle between attachment points is  $\theta_p$ . It is made up of a x and y component, the following equation was used for the calculations

Table 1, Attachment point on the platform

	$Gt_{xi} =$	$r_p \cos(\lambda_i)$
$Gt_i =$	$Gt_{yi} =$	$r_p \sin(\lambda_i)$
	$Gt_{zi} =$	0

Where  $r_p$  is the radius of the platform,  $i$  is the number of the attachment point,  $\lambda_i = (i\pi/3) - (\theta_p/2)$  when  $i = 1, 3$  or  $5$  and  $\lambda_i = \lambda_{i-1} + \theta_p$  when  $i = 2, 4$  or  $6$ .



### 6.1.2 Base calculations

The calculations on the base follow a similar pattern to the ones on the platform. The separation angle between attachment points on the base is called  $\theta_b$  and the coordinates for the first attachment point is  $B_1$ , which is calculated using the following formula.

Table 2, Attachment point on the base

$B_i =$	$B_{xi} =$	$r_b \cos(v_i)$
	$B_{yi} =$	$r_b \sin(v_i)$
	$B_{zi} =$	0

Where  $r_b$  is the radius of the base,  $v_i = (i\pi/3) - (\theta_b/2)$  when  $i = 1, 3$  or  $5$  and  $v_i = v_{i-1} + \theta_b$  when  $i = 2, 4$  or  $6$ . Using the angle between the attachment points and the symmetric nature of a Stewart platform design it is fairly easy to calculate the attachment point for all the actuators.

### 6.1.3 Rotation Matrix

Next we create a rotational matrix  ${}^B R_T$  based on what angle the platform is at, this is represented in the equation as on  $\alpha$ ,  $\beta$  and  $\gamma$ .

Table 3, Rotational matrix equation

$${}^B R_T = R_z(\gamma)R_y(\beta)R_x(\alpha) = \begin{array}{|c|c|c|} \hline r_{11} & r_{12} & r_{13} \\ \hline r_{21} & r_{22} & r_{23} \\ \hline r_{31} & r_{32} & r_{33} \\ \hline \end{array}$$

Table 4, Rotational matrix indepth makeup

$\cos\beta * \cos\gamma$	$\cos\gamma * \sin\alpha * \sin\beta - \cos\alpha * \sin\gamma$	$\sin\alpha * \sin\gamma + \cos\alpha * \cos\gamma * \sin\beta$
$\cos\beta * \sin\gamma$	$\cos\alpha * \cos\gamma + \sin\alpha * \sin\beta * \sin\gamma$	$\cos\alpha * \sin\beta * \sin\gamma - \cos\gamma * \sin\alpha$
$-\sin\beta$	$\cos\beta * \sin\alpha$	$\cos\alpha * \cos\beta$

### 6.1.4 Actuator length

The vector P describes the position of the platform in x, y and z coordinates. Using  ${}^B R_T$ ,  $G T_1$ ,  $B_1$  and P we can calculate the vector  $L_i$ , as shown in the following formula.

$$L_i = R_{xyz} G T_i + P - B_i \quad (i = 1, 2, 3, \dots, 6)$$

The actuator length of each leg can be calculated using the following formula, because the actuator length is  $l_i = \|L_i\|$

$$l_i = \sqrt{((P_x - B_{xi} + G T_{xi} * r_{11} + G T_{yi} * r_{21})^2 + (P_y - B_{yi} + G T_{xi} * r_{12} + G T_{yi} * r_{22})^2 + (P_z + G T_{xi} * r_{13} + G T_{yi} * r_{23})^2)}$$

## 6.2 Modelling

Due to being designed from scratch the motion platform's capabilities were largely unknown. it was decided to create a 3D model of the motion platform and then simulate it to see if the servomotors the school had would be sufficient to move the motion platform at the desired speeds. Another important part of testing the model was that if any major faults are found, they could be fixed and I can make any necessary adjustments to the components size. Due to some problems getting the

simulation to work, I made a few extra models with different parameters and configurations to test as well.

### **6.2.1 Searching for a program**

I started by trying to use the 3D modelling software I am most familiar with, Solid Edge. While I was successful in creating mock versions of all the necessary parts, I was unable to properly assemble them. I then began to search for an alternative software to use, the Mevea modeller was one that was recommended, due to the fact that the company that makes it is also making motion platforms. Unfortunately, I ran into similar problems with it, and was unable to assemble the motion platform. It would seem that Stewart platforms are too complicated for some programs, due to the way all the actuators connect to the platform and affect its position. The next program I tried was Catia and while it was able to create a mock model of the system, I was unable to simulate it the way I wanted. Finally, after asking around, I heard of a student that had modelled and simulated a delta robot using the NX designer and Nx solver. Knowing that a motion platform and a delta robot are very similar, I asked the teacher who was working with that project for help. I then began learning how to use Nx and after I got the hang of the Nx designer, I recreated the motion platform in it.

### **6.2.2 Nx 10**

Nx 10 is a versatile piece of software designed by Siemens. It offers a variety of uses: modelling, designing, engineering and simulating. Fairly often these uses are separated into different programs, but in Nx they are all combined. Nx 10 is a robust program, that can model and simulate rather complex models and systems. This is very useful since some software cannot simulate motion platforms, due to how the position and angle of the platform depends on the length of the actuators.

### **6.2.3 Mechatronics Concept Designer (MCD)**

The mechatronics concept designer or MCD is a built-in part of Nx 10 that can be used to make kinematic simulations of various models. MCD uses both mechanical design and automation design, this makes it possible to find the best configuration quicker. The simulations in MCD are powered by NVIDIA PhysX and have to do with how the parts react to motion caused by gravity or an actuator. In MCD you can define the moving parts of a system, where the joints are and what surfaces collide with each other. It is also possible to connect a physical PLC to the MCD program, allowing you to simulate a virtual system with the intended controls. A prominent use for MCD is to test machinery before any prototypes are made.

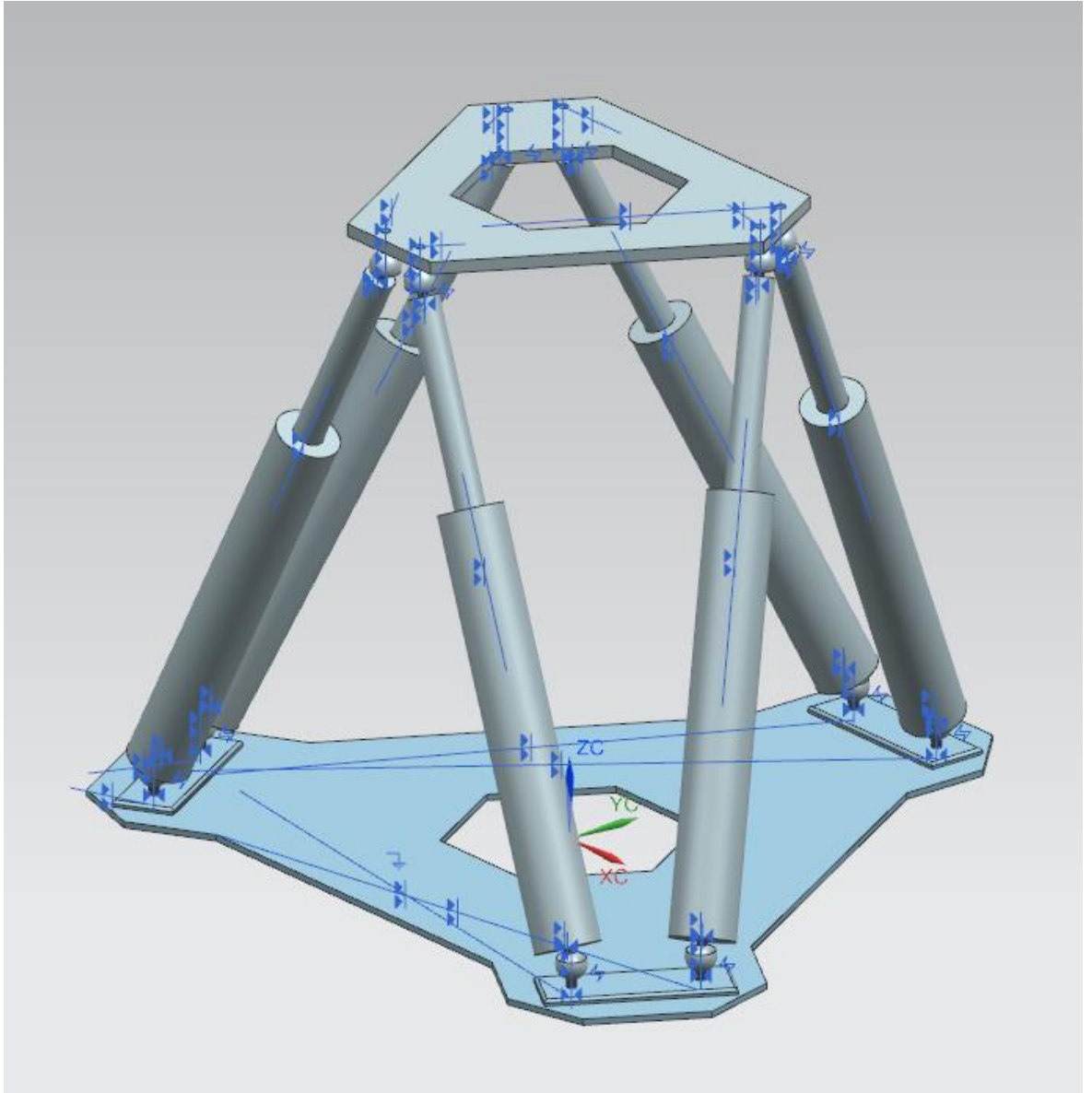

Figure 5, The rough model of motion platform in Nx 10

## **7 SIMULATION**

While I was able to get the MCD simulation part to work fairly easily, I was having a lot of trouble starting the Nx solver's simulation. In the MCD simulation I was able to move the motion platform with its actuators, but was unable to gain any information about its capabilities. When I got the Nx solver to work and moved the model from the MCD to it one of the functions I had built the model around, called collision body was not present; this made the motion platform no longer work and I had to find a work around.

### **7.1 Limitations and failure**

After consulting a nearby company called Ideal PLM, that sells software and trains users to use it, including Nx 10, I was able to find a work around of sorts. Unfortunately, this work around made it impossible to get the desired information out of the simulation, as I am unable to directly control the actuators and they only repeated a fixed motion. Without the ability to set the force with which the actuators move the motion platform, I had no way of measuring if the intended motors will be able to move the motion platform at the desired speed and acceleration while carrying an occupant. Motion platforms need to be able to move with a fairly high speed and acceleration in order to fool human senses, so knowing if the motors are capable of achieving this is very important.

### **7.2 Possible future development**

It might be possible to use a different program to analyze the model's capabilities, but I unfortunately do not have the time to try to find one, let alone to adapt the model to it. This is very frustrating since I have spent a considerable amount of time trying to get it to work, only to have it fail while coming so close to a solution. While talking to Ideal PLM I heard that the next version of Nx called Nx 11 will have more features and capabilities and might be able to be of use in solving this

problem, unfortunately SeAMK will not update to Nx 11 any time soon, so I do not have access to it.

## 8 CONCLUSIONS

Due to the complexity of motion platforms, it is worth considering changing the motion platform from 6dof to 3dof. This would simplify the construction and how it is controlled, while keeping most of the core movements needed to simulate motion. I believe that SeAMK would benefit from having a motion platform, as it can be used as a showpiece and programming it could be an interesting addition to the training facilities. Motion platforms already have some fascinating applications and it is possible that more can be discovered in the near future. I sincerely hope that SeAMK continues to develop this project in the future and in general continues to develop new and interesting technologies.



## BIBLIOGRAPHY

- Page R. Brief History of Flight Simulation. [Online publication]. [Ref 08.2015]. Available at:  
<http://citeseerx.ist.psu.edu/viewdoc/download?doi=10.1.1.132.5428&rep=rep1&type=pdf>
- Bowen S., Oakley B. & Barnett J. May 2006. Effects of Motion on Skill Acquisition in Future Simulators. [Online publication]. United States Army Research Institute for the Behavior and Social Sciences. [Ref 08.2015]. Available at:  
<http://www.dtic.mil/cgi-bin/GetTRDoc?Location=U2&doc=GetTRDoc.pdf&AD=ADA452066>
- Augusto B. & Loureiro R. 2009. Motion Cueing in the Chalmers Driving Simulator: A Model Predictive Control Approach. [Thesis]. Chalmers University of Technology. [Ref 02.2015]. Available at:  
<http://publications.lib.chalmers.se/records/fulltext/98871.pdf>
- Johnson D. April 2005. Introduction to and Review of Simulator Sickness Research. [Online publication] U.S. Army Research Institute. [Ref 03.2016]. Available at: <http://permanent.access.gpo.gov/lps94125/RR%25201832.pdf>
- Wang Y. September 2008. Symbolic Kinematics and Dynamics Analysis and Control of a General Stewart Parallel Manipulator. [Thesis]. State University of New York at Buffalo. [Ref 01.2015]. Available at:  
[http://mechatronics.eng.buffalo.edu/publications/thesis/YaoWang\\_MSThesis.pdf](http://mechatronics.eng.buffalo.edu/publications/thesis/YaoWang_MSThesis.pdf)
- Anaheim automation, Inc. Linear actuator guide. [Online publication]. [Ref 11.2014]. Available at:  
<http://www.anaheimautomation.com/manuals/forms/linear-actuator-guide.php#sthash.dLxoWbWk.NPdJRIK4.dpbs>
- DeClerck J. 17 November, 2014. Linear actuators basics and how to. [Online publication]. Fircelli Automations. [Ref 01.2015]. Available at:  
<https://www.fircelliauto.com/blogs/news/18090539-linear-actuator-how-to>
- Hellman T. [Seamk virtual reality laboratories home page]. Seinäjoki university of applied sciences, Finland. [Ref 17.08.2016]. Available at:  
<http://www.seamk.fi/fi/Koulutus/Opiskelijana-SeAMKissa/Oppimisymparistoja/Tekniikan-laboratorio/Virtuaalitekniikan-laboratorio>
- Springer K., Gattringer H. & Bremer H. 2011. Towards Washout Filter Concepts for Motion Simulators on the Base of a Stewart Platform. [Online Publication]. Insti-

tute for Robotics, Johannes Kepler University Linz, Austria. [Ref 06.09.2016]. Available at: <http://onlinelibrary.wiley.com/doi/10.1002/pamm.201110448/epdf>

Siemens Product Lifecycle Management Software Inc. Nx 10 Product description. [Online publication]. [Ref 08.08.2016]. Available at: [https://www.plm.automation.siemens.com/en\\_us/products/nx/10/index.shtml](https://www.plm.automation.siemens.com/en_us/products/nx/10/index.shtml)

Visual System. [Online publication]. [Red 08.09.2016]. Available at: [https://en.wikibooks.org/wiki/Sensory\\_Systems/Visual\\_System](https://en.wikibooks.org/wiki/Sensory_Systems/Visual_System)

Vestibular System. [Online publication]. [Red 09.09.2016]. Available at: [https://en.wikibooks.org/wiki/Sensory\\_Systems/Vestibular\\_System](https://en.wikibooks.org/wiki/Sensory_Systems/Vestibular_System)

Somatosensory System. [Online publication]. [Red 12.09.2016]. Available at: [https://en.wikibooks.org/wiki/Sensory\\_Systems/Somatosensory\\_System](https://en.wikibooks.org/wiki/Sensory_Systems/Somatosensory_System)

## **APPENDICES**

APPENDIXES 1. Drawings of the motion platforms parts

APPENDIXES 1. Drawings of the motion platforms parts

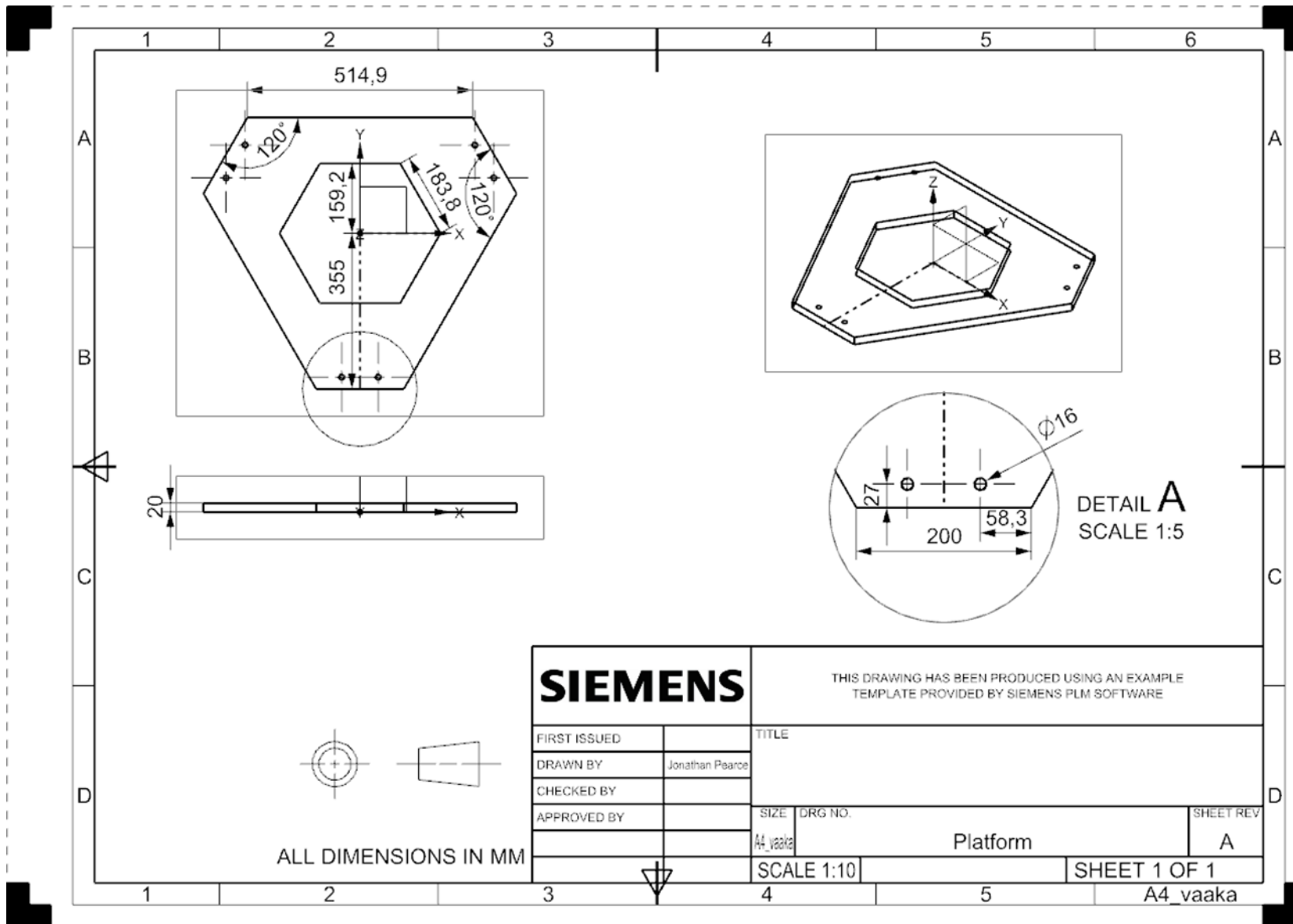

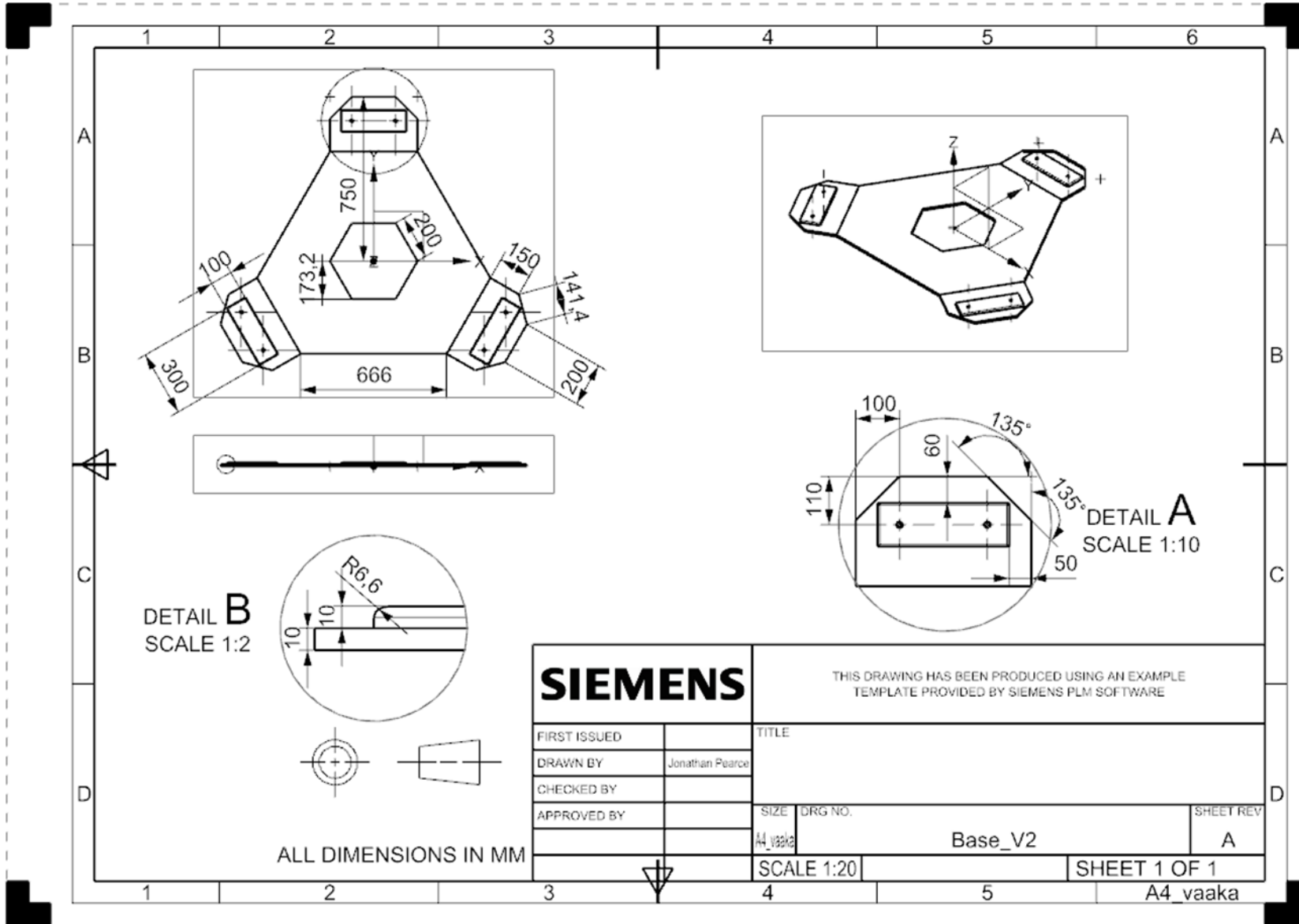

DETAIL B  
SCALE 1:2

DETAIL A  
SCALE 1:10

ALL DIMENSIONS IN MM

<b>SIEMENS</b>		THIS DRAWING HAS BEEN PRODUCED USING AN EXAMPLE TEMPLATE PROVIDED BY SIEMENS PLM SOFTWARE	
FIRST ISSUED		TITLE	
DRAWN BY	Jonathan Pearce		
CHECKED BY			
APPROVED BY		SIZE	DRG NO.
		A4_vaaka	Base_V2
			SHEET REV
			A
		SCALE 1:20	SHEET 1 OF 1
			A4_vaaka

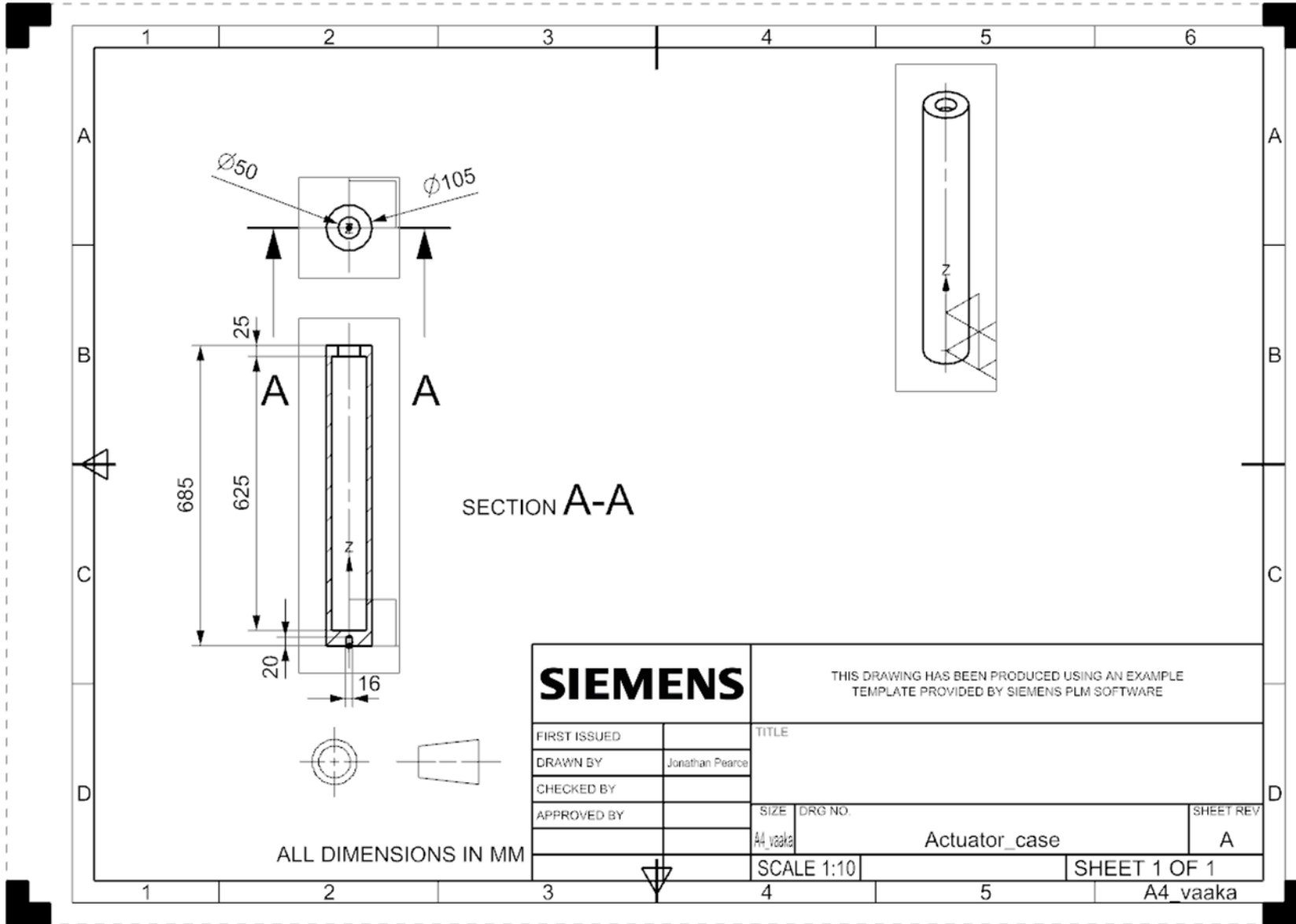

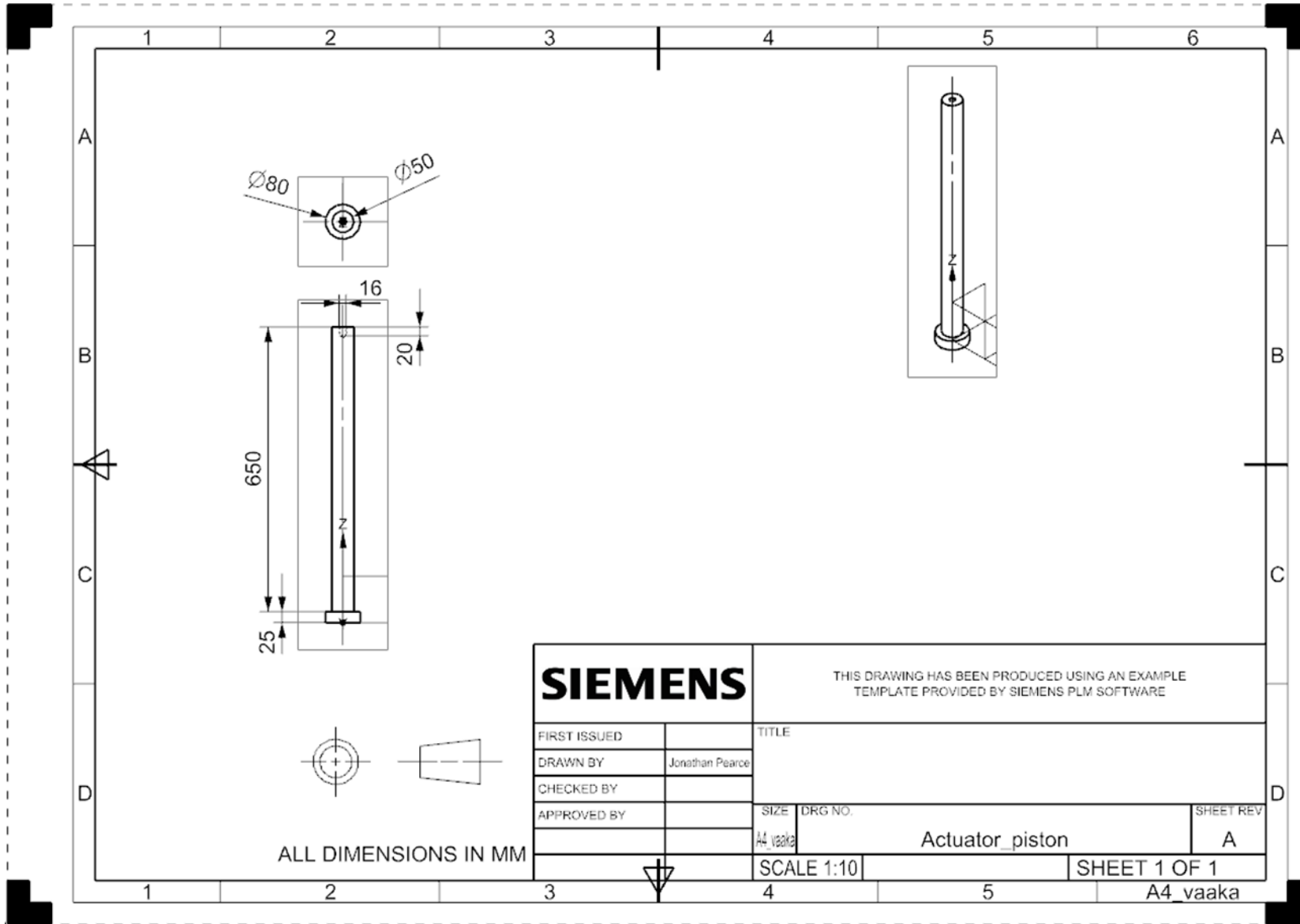

<b>SIEMENS</b>		THIS DRAWING HAS BEEN PRODUCED USING AN EXAMPLE TEMPLATE PROVIDED BY SIEMENS PLM SOFTWARE		
FIRST ISSUED		TITLE		
DRAWN BY	Jonathan Pearce	TITLE		
CHECKED BY		TITLE		
APPROVED BY		SIZE	DRG NO.	SHEET REV
		A4_vaaka	Actuator_piston	A
ALL DIMENSIONS IN MM		SCALE 1:10	SHEET 1 OF 1	
		A4_vaaka		

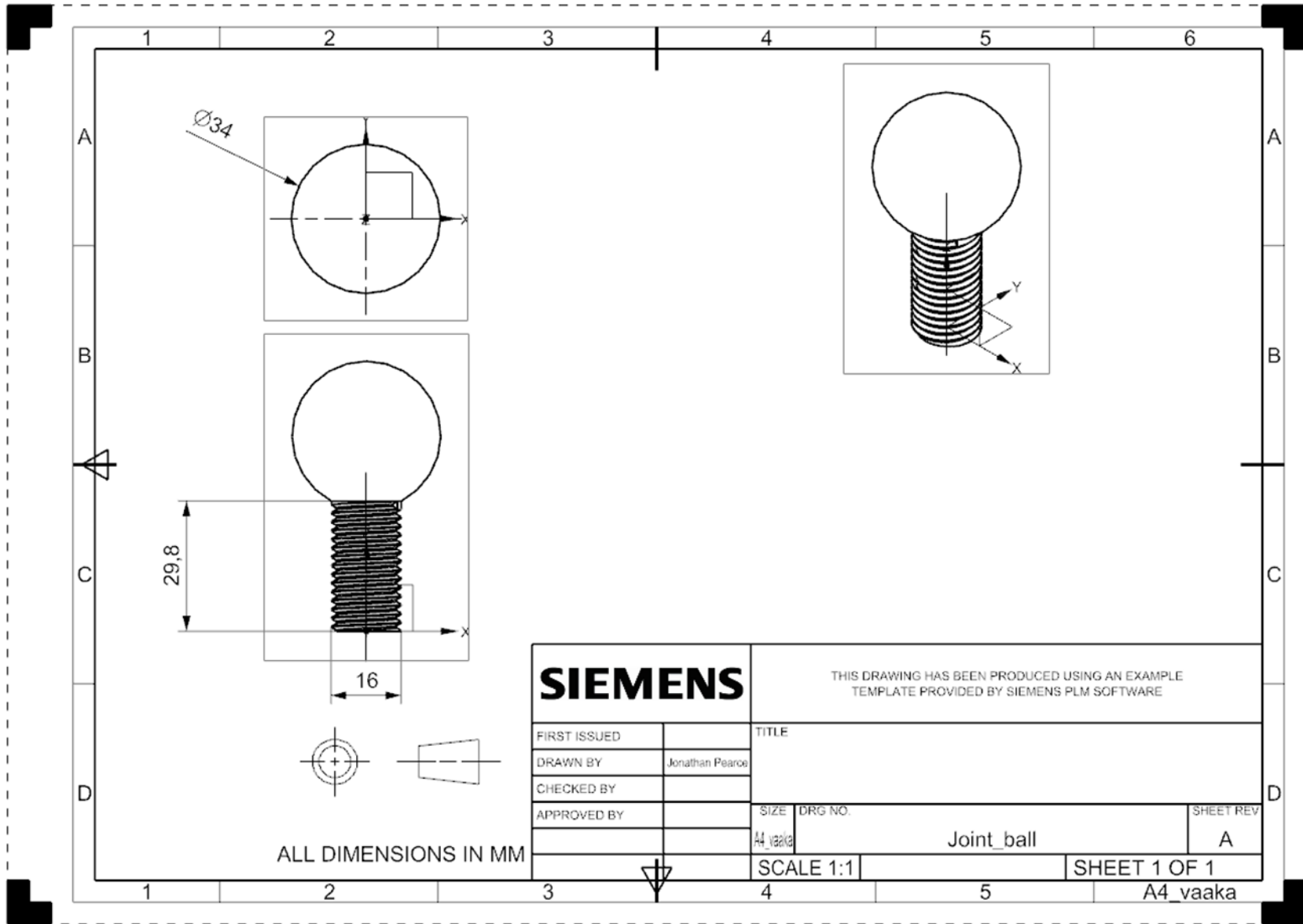

<b>SIEMENS</b>		THIS DRAWING HAS BEEN PRODUCED USING AN EXAMPLE TEMPLATE PROVIDED BY SIEMENS PLM SOFTWARE		
FIRST ISSUED		TITLE		
DRAWN BY	Jonathan Pearce	Joint_ball		
CHECKED BY		SIZE	DRG NO.	SHEET REV
APPROVED BY		A4_13212		A
		SCALE 1:1	SHEET 1 OF 1	
		A4_vaaka		



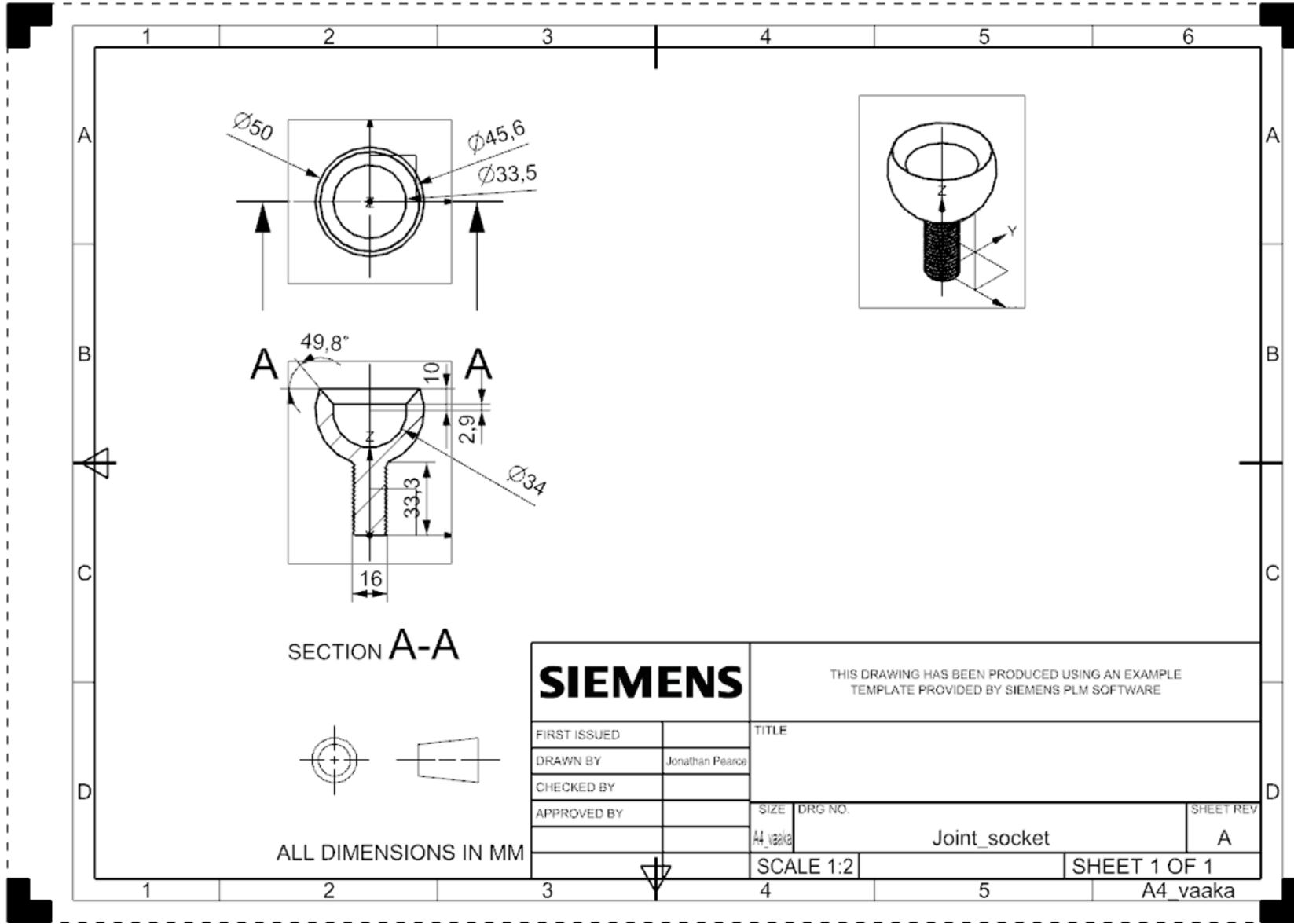

SECTION A-A

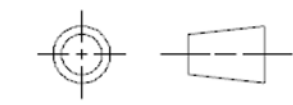

ALL DIMENSIONS IN MM

<b>SIEMENS</b>		THIS DRAWING HAS BEEN PRODUCED USING AN EXAMPLE TEMPLATE PROVIDED BY SIEMENS PLM SOFTWARE		
FIRST ISSUED		TITLE		
DRAWN BY	Jonathan Pearce			
CHECKED BY				
APPROVED BY		SIZE	DRG NO.	SHEET REV
		A4_vaaka	Joint_socket	A
		SCALE 1:2	SHEET 1 OF 1	
			A4_vaaka	