

RAPID PROTOTYPING IN MECHANICAL ENGINEERING

Ferran Sánchez Monferrer

Bachelor's thesis
May 2018
Mechanical Engineering

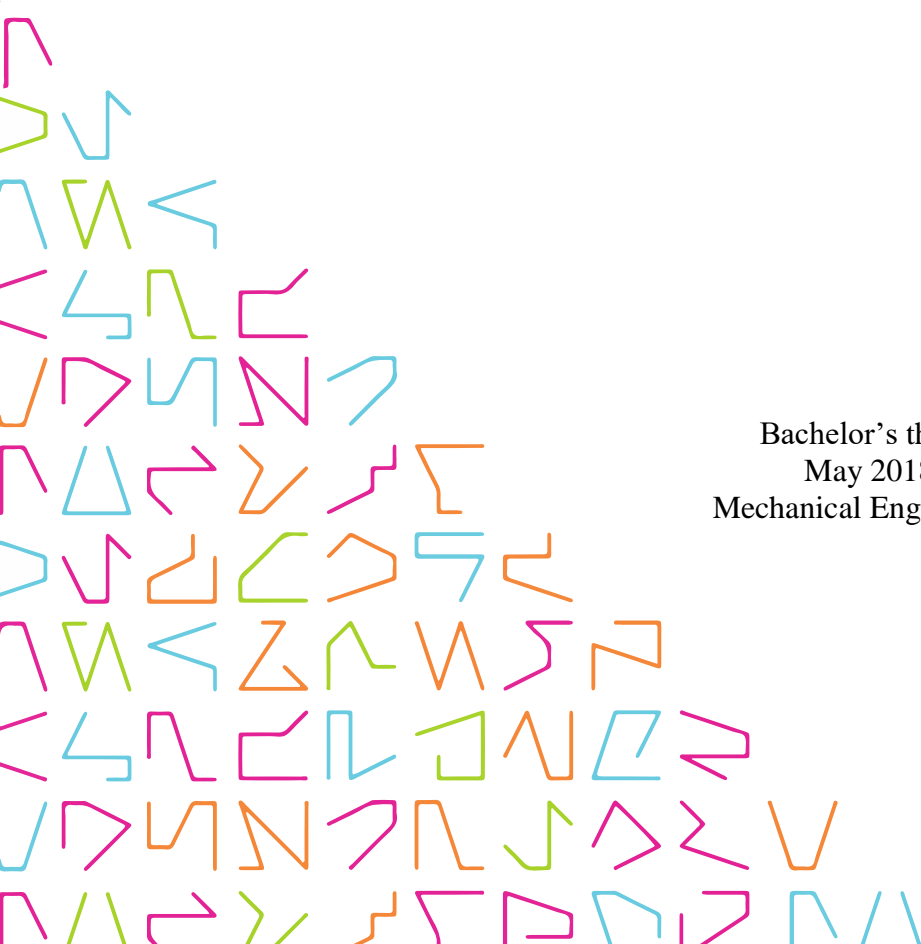

ABSTRACT

Tampereen ammattikorkeakoulu
Tampere University of Applied Sciences
Mechanical Engineering

FERRAN SÁNCHEZ MONFERRER
Rapid Prototyping in Mechanical Engineering

Bachelor's thesis 50 pages, appendices 12 pages
May 2018

Until the invention of rapid prototyping, physical mechanical prototypes were machined, making the process expensive and slow. Rapid prototyping allows us to build functional prototypes directly from CAD program. Due to the short-term life of commercial products, rapid prototyping technologies are becoming a more influential manner on the industry.

The purpose of this study was to gather information on rapid prototyping technologies and 3D scanners in order to be used in the future as educational material in TAMK for incoming students. Another objective was to test the TAMK guides of the 3D scanner that TAMK possesses and apply the guides to a larger object.

The theoretical content was collected from the sources which can be found in the references below. The test of the TAMK guides of the 3D scanner consisted on scanning the boat provided by the ACOLOR project. The scan used was the "HandySCAN 700" made by Creafom. The scanned data was post-processed in the laboratory of TAMK with VXelements.

All the information of the theoretical content in rapid prototyping consisted on the basic process on printing, the materials used for printing and its advantages and disadvantages of printed prototypes. In the theory of 3D scanners the different technologies currently used were explained. The result obtained with the scan of the ship and its post-processing was the internal surface of the ship. The members of ACOLOR project assembled the structures modelled with the scanned surface.

The theoretical content resulted in a basic guide of rapid prototyping and 3D scanners that future students could create complete course if they are still working on it. The results of the scan and the post-processing of the boat indicate that the optimal workflow was found to post-process large and symmetrical objects in VXelements. In addition, the limitations and the optimization of the computer of the laboratory of TAMK were found.

Key words: rapid prototyping, 3D scanner, VXelements

CONTENTS

1	INTRODUCTION	5
1.1	What is a Prototype?	5
1.2	What is Rapid Prototyping?	6
1.2.1	Basic Process.....	7
2	RAPID PROTOTYPING	9
2.1	Process of RP	9
2.1.1	Modelling	10
2.1.2	Tessellation of the Model.....	11
2.1.3	Slicing the Model and Add supports.....	12
2.1.4	Print of the Model	15
2.1.5	Post-processing	16
2.1.1	Observations.....	18
3	ADDITIVE LAYER MANUFACTURING TECHNIQUES	19
3.1	Stereolithography.....	19
3.2	Multi Jet Modelling	22
3.3	Fused Deposition Modelling.....	25
3.3.1	Metal 3D Printing.....	32
3.4	Selective Laser Sintering	33
3.4.1	Metal 3D Printing.....	36
3.5	Laminated-Object Modelling.....	37
4	3D SCANNER	41
5	Practical Case: Scan of the Boat for ACOLOR project	44
6	CONCLUSSIONS & DISCUSSIONS	46
	REFERENCES.....	47
	APPENDICES	51
	Appendix 1. Scanning Process of the boat of ACOLOR project.....	51
	Appendix 2. Hardware needed for the scan	60

GLOSSARY

ABS	Acrylonitrile Butadiene Styrene
ADAM	Atomic Diffusion Additive Manufacturing
CAD	Computer-Aided Design
DMLS	Direct Metal Laser Sintering
FDM	Fused Deposition Modelling
FEM	Finite Element Method
HIPS	High Impact Polystyrene
LOM	Laminated-Object Modelling
MJM	Multi Jet Modelling
PA	Nylon
PETG	Polyethylene Terephthalate Glycol-modified
PC	Polycarbonates
PLA	Polylactic Acid
PP	Polypropylene
PVA	Polyvinyl Alcohol
RP	Rapid Prototyping
SL	Stereolithography
SLM	Selective Laser Melting
SLS	Selective Laser Sintering
SW	SolidWorks
TPU	Thermoplastic Polyurethane
UV	Ultraviolet

1 INTRODUCTION

1.1 What is a Prototype?

A prototype is a model as similar as possible, or if necessary equal, to the final product. It is produced to have the same specifications and functionalities. There are two main objectives when a prototype is manufactured. The first objective is to improve communication between the designer and the engineer. Improving communication reduces the design time and that is reflected in the cost reduction. The second one is to test and verify if all the needs and applications of the product have been met. This kind of processes is iterative, for that reason, you need machines that can manufacture prototypes at a great speed with the lowest possible cost. (Smith, 2015) Hence, the need for Rapid Prototyping (RP).

As will be shown, there are different techniques of RP and each one build different kinds of prototypes, thanks at the characteristics of the material and the process of building the prototype. Therefore, all prototypes will be explained. (Gebhardt, 2003) (Komin, 2017) (CIM UPC)

1. Virtual Prototype.

Models developed in 3D Computer-Aided Design (CAD) program. With these prototypes is ease to verify the aesthetic, proportions and textures and also test the strength with Finite Element Method (FEM). The advantage of virtual prototypes with others kind of prototypes is the reduced price of the verifications and the tests.

2. Aesthetic Prototype.

Physical prototypes used to verify three-dimensionally the aesthetic, the proportions and the ergonomic. These prototypes are commonly built with a cheaper material than the final product material. Due the objectives of the aesthetic prototype, the aesthetic prototype needs to be accurate with the dimensions, the details and the final finish.

3. Functional Prototype.

Physical prototypes used to test the functionality and the strength. These prototypes could be built of plastics if you just want to test the functionality or with the final material if you just want to test functionality and strength. Functional prototypes do not have to be built by the machines that will build the final product.

4. Pre-Production Prototype.

Prototypes build before the production of the final product. Pre-production prototype is built with the same machines that will build the final product. This prototype is used to verify the machines and the work flow.

1.2 What is Rapid Prototyping?

Nowadays, RP refers to the layer-by-layer fabrication of the physical prototypes from a CAD program. Layer-by-layer fabrication build the model by slicing the model in thin cross sections of the model, that will be deposited one on top of the other, until the model is completed. Layer-by-layer fabrication is also known as additive manufacturing.

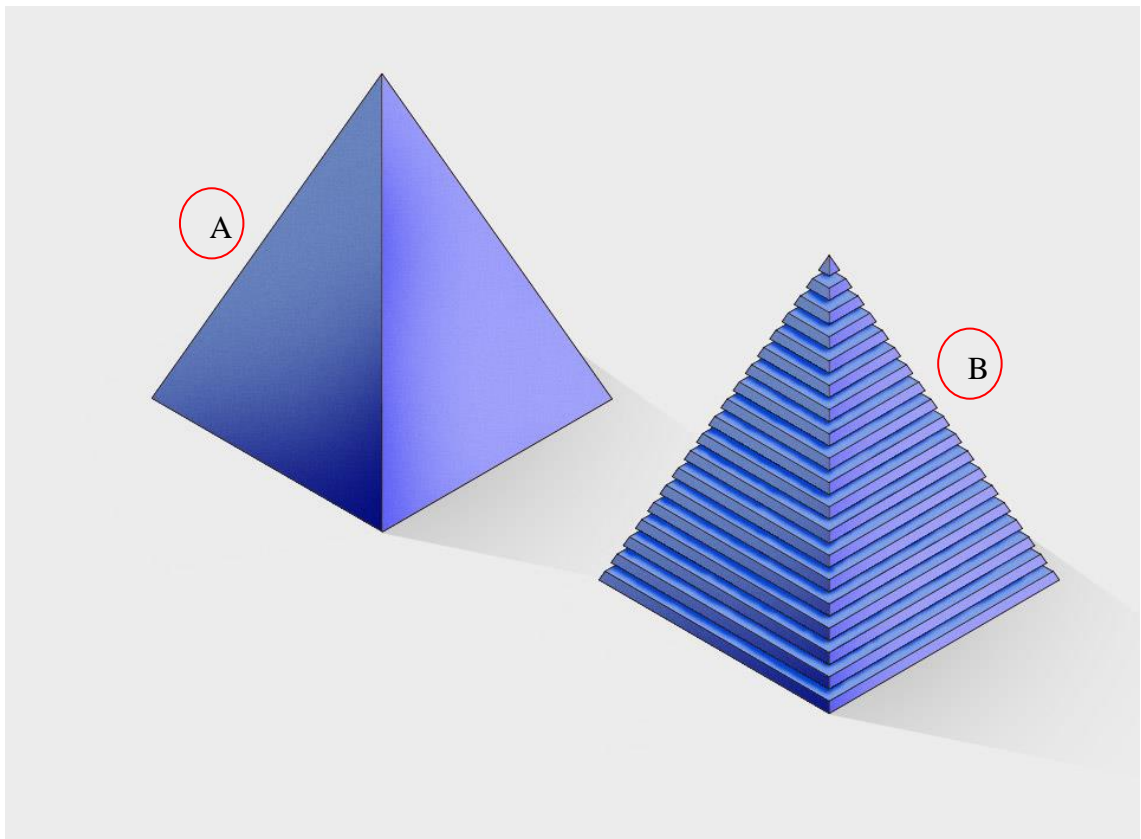

FIGURE 1.2.1 CAD/Sliced model (BCN3D)

Figure 1.2.1 shows the differences between the CAD model (A) and the model generated by the slicer (B). The slicer model is simply the representation of the CAD model divided into thin layers.

The advantage of additive manufacturing is the ability of building complex shapes, in contrast to the traditional methods that have difficulties, e.g. machining. As an example of complex shapes, RP can build intricate internal structures and objects inside objects if the configuration of the machine and the slicer is correct.

RP machines decrease the time of the operator. The operator only has to set up the control program and the machine will start manufacturing the model without stops until the prototype is completed. Post-processing is usually necessary. The operator will do the post-processing with the required machines or tools. Nonetheless, the time and the number of operations decrease compared to the traditional machining processes.

Although RP is only a method of manufacturing, 3D scanners make a great combination with RP. 3D scanners allow us to obtain a 3D model in CAD program of a physical object without complication in CAD modelling and without wasting time. Due of the capability of 3D scanners to generate virtual prototypes rapidly, this thesis explains how the most commons 3D scanners work, how to use the 3D scanner “HandySCAN 700” made by Creaform and the program necessary for scanning and the post-processing.

1.2.1 Basic Process

In order to understand the RP, firstly we have to know what a typical manufacturing flow is. It is crucial to consider that RP provides the capacity of repeating and making some process of the typical manufacturing stream in a lower cost. (Cooper, 2001)

Next, all the phases of development of a product are explained. These phases are ordered but it taking into account that this order can be iterative each time.

1. The concept.

A new product or a modification of a previous one must start with an idea, a concept. This concept comes from a need.

2. Preliminary design.

The design will be done in a CAD program. This design will be generated from iterations; these iterations will end when the product satisfies all the requirements. In this phase we can also make other preliminary checks, such as a stress analysis or a rendering to visualize the final product.

The two previous phases can also be supported by reverse engineering thanks to a 3D scanner.

3. Prototype.

When the preliminary design is finished, the prototype is manufactured. This prototype will be able to observe all the functional characteristics (not those of elasticity), in order to verify the product. If the final product does not meet the demand, it will return to the design phase to modify the problems. As you can see, these phases are iterative and cyclical, for this reason the RP has become popular in these last decades. The RP manufactures prototypes at a speed and repeatability greater than that of hand-working and machining.

4. Short-run production.

Sometimes, it is necessary to make a short production of the product for testing, verification, customer satisfaction, etc. For these cases we can use the RP to make it more inexpensively. It is crucial that all errors or flaws have been detected before beginning this phase.

5. Final production.

In this phase the parts of the product will normally be manufactured with other methods. Day after day, the RP is becoming more popular in this phase. There is still time for it to replace completely some process.

Then, the main advantages that RP brings to the typical manufacturing flow are explained.

(Elanchezhian, Sunder Selwyn, & Shanmuga Sundar, 2007)

1. Reduction of operating cost.
2. Improve process development.
3. Fast elimination of design errors.
4. Facilitate concurrent engineering.
5. Reduction of time in development.
6. Facilitate the identification of product manufacturing problems.
7. For complex models, RP is preferred.
8. Repeatable.

RP brings advantages in time and costs of production that make RP become increasingly important in the industry. However some disadvantages appear in the generated prototype. The disadvantages are explained below.

1. The materials of the prototypes are different from those specified in the product.
2. Poor mechanical properties.
3. It is not cost effective when it is produced in huge numbers.

2 RAPID PROTOTYPING

All the manufacturing processes explained in this thesis are additive manufacturing processes. Therefore we must keep in mind that the models manufactured are from layers that will be deposited on top of the previous one.

TABLE 2.1 Summary of RP technologies (Elanchezhian, Sunder Selwyn, & Shanmuga Sundar, 2007)

Supply phase	Technology	Layer creation technique	Phase change type	Material
Liquid	Stereolithography (SL)	Liquid layer curing	Photopolymerization	Photopolymers
	Multi jet modelling (MJM)	Injection and curing	Photopolymerization	Photopolymers
	Fused deposition (FDM)	Extrusion of melted polymer	Solidification	Polymers, wax and metals
Powder	Selective laser sintering (SLS)	Layer of powder	Sintering and solidification	Polymers, metals, ceramics and sand
Solid	Laminated-object modelling (LOM)	Cutting and gluing of sheet	No phase change	Paper and polymers

Table 2.1 is the summary of all the RP technologies explained in this thesis. RP technologies are organized into 3 groups according to the supply phase of the materials. The table specifies how the material is applied in the layer, which phase change has in the creation of the layer and which materials can be used in each RP technology.

2.1 Process of RP

This section explains the importance of knowing limitations of the tools and machines that are used. This section explains each phase in order which is illustrated with a basic but representative example. All the processes of RP (using an FDM desktop printer) will

be done processing 1 sphere of 50mm of diameter. (Gebhardt, 2003) (K. Kamrani & Abouel Nasr, 2010)

2.1.1 Modelling

The model will be done in a CAD program. A CAD program is used because it generates a model represented mathematically and it defines easily the enclosed volume; it is important for the slicer to differentiate the outside from the inside in the contour surfaces.

Modelling is one of the most important phases of RP considering that the way the model ends for the following phases affects the time and the final finish of the prototype. When the model is designed, it is important to consider the position of the model when it is manufactured because, depending on the direction of the load and the orientation of the layers, the strength of the object will be affected.

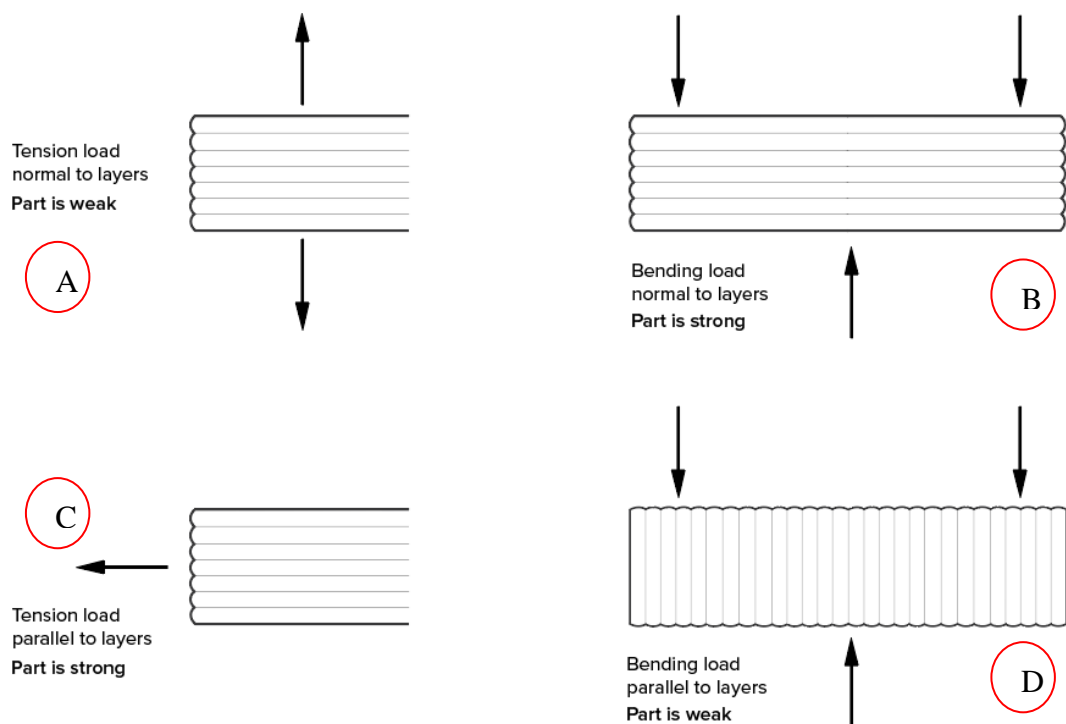
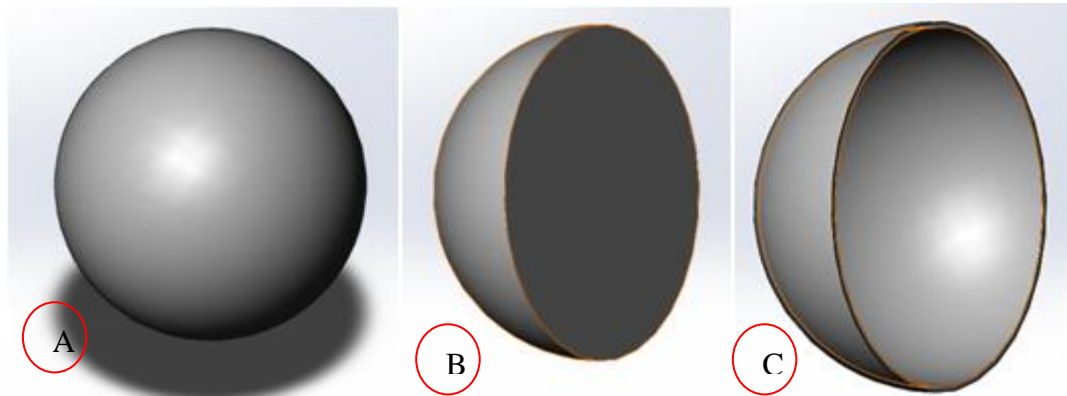

FIGURE 2.1.1.1 Tension load in function of direction of layers (Hudson, 2018)

In figure 2.1.1.1 it is represented when the object is strong in function of what was explained above. It can be seen that in cases A and D of the Figure 2.1.1.1, the load affects the layers one by one. While in cases B and C, the load affects the layers as a group. For that reason, when the load affects the layers as a group, the object is stronger.

SolidWorks (SW) program was used to model the sphere. 3 different ways to model the sphere were thought for printing in FDM and for applying a different post-processing. In Figure 2.1.1.2, the 3 models are observed.



2.1.1.2 Models of the sphere

In Figure 2.1.1.2, there are 3 models of the sphere. A is a sphere, the problem will arise when A is printing. The bottom of A is an overhang that will have to use supports, these supports will make the bottom of the sphere have a bad final finish. B is a hemisphere, this eliminates the overhang of the sphere because 2 tops will be printed and then stuck. C is an empty hemisphere in order to have control in the thickness of the wall. The slicers have an automatic function to empty the inside of the object. But this automatic method does not allow to have the maximum control of the thickness of the wall.

2.1.2 Tessellation of the Model

In order to represent the model for the slicer, the file must be converted to STL format. The STL format represents the model as a mosaic of triangles. The STL format only has flat surfaces, for this reason, more triangles will be required to represent a curve. When more precision is required, more triangles will be necessary and this has an effect on an increase in the size of the file. If the tolerance of deviation is not well chosen, the resulting geometry flat faces can be observed instead of being curved faces. On the other hand, if the tolerance is exceeded in a very small size, the file could become too large to be generated and too difficult to be manipulated.

After modelling the spheres, they were saved in STL files. The sphere was saved with 2 different accuracies, in order to observe the differences in the file size and in the quality of the representation of the sphere.

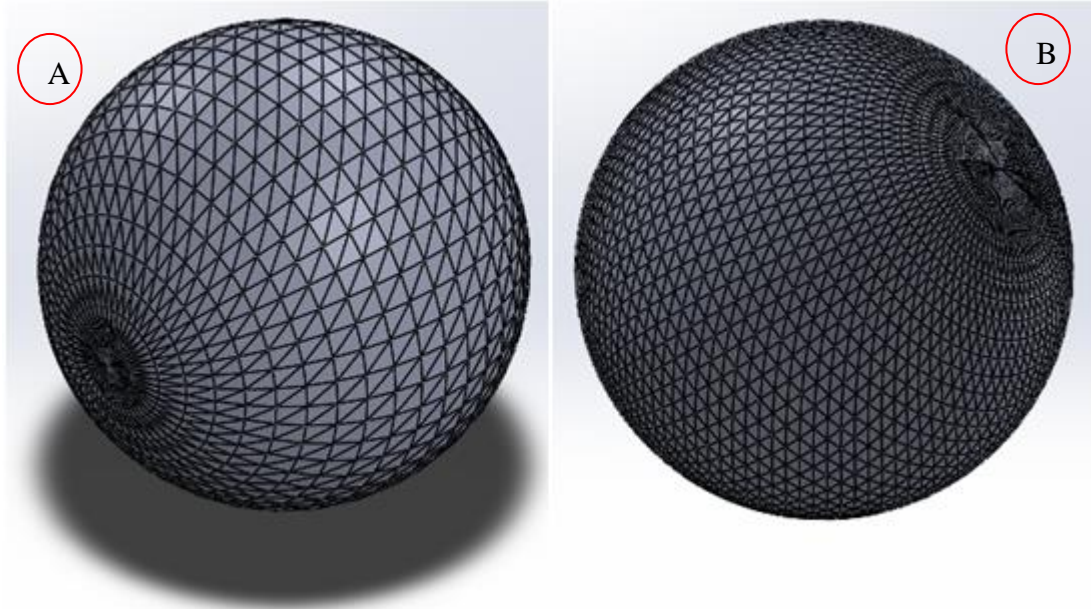

2.1.2.1 STL files of the sphere

In Figure 2.1.2.1, it could be observed that the number of triangles used to generate a sphere depends on the accuracy that is required. A has a deviation tolerance of 0.41239305mm and the generated file is 115kb. B has a deviation tolerance of 0.15890374mm and the generated file is 301kb. Normally, a lower tolerance is used for small and complex objects in order to observe all the details. On the other hand, a larger tolerance is used for larger objects in order to avoid difficulties in the slicer computerization. In the case of the sphere, model B will be used, because the object is a small object and is curved. This shape is complex to be represented with flat faces.

2.1.3 Slicing the Model and Add supports

The model in STL file format is sliced into parallel layers that represent the model. These layers will have the characteristics that are given in the program. The slicer generates appropriate commands for the machine.

The layer height has a great impact on the time and the final finish of the piece. This is a variable of the slicers. Increasing the layer height reduces the manufacturing time but accuracy is lost in the final finish and the resistance is also affected. On the other hand, reducing the distance, we gain quality in the final finish and resistance but more manufacturing time is needed. Currently some slicers are able to vary the layer height at different heights of the piece where it is necessary, making possible a faster printing in areas where high quality is unnecessary.



FIGURE 2.1.3.1 Comparison of different layer heights (Průša, 2017)

Figure 2.1.3.1 is the comparison of time and final finish respect to the layer height. This test is made by “Prusa Research” that updated the slicer “Slic3r” with an add-on. This add-on allows to have a smooth variable layer height depending on the height of the object. The printed object is “Marvin”, a test of “3D Hubs”.

The slicer may also generate auxiliary supports to help the manufacturing of the model. These supports are generated, depending on the machine, to support overhangs, internal cavities and thin-wall sections.

After saving the 3 spheres in STL files, the STL files will be sent to the slicer so that the program is generated according to the RP technology and the characteristics of the machine. The slicer "Slic3r" was used to generate the programs. "Slic3r" is a free program that works with almost all desktop FDM printers on the market.

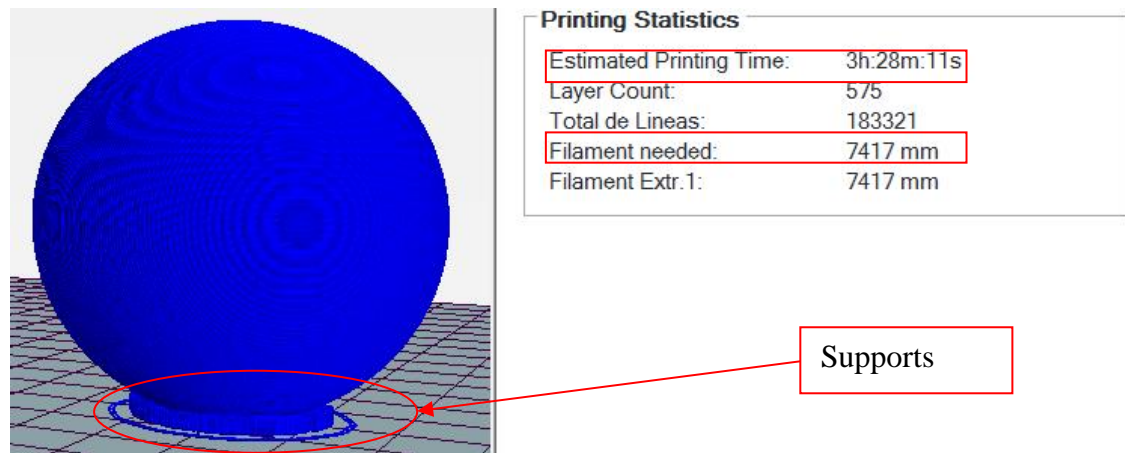

FIGURE 2.1.3.2 Program of sphere

Figure 2.1.3.2 requires supports to be printed making a bad final finish in the bottom. This sphere is the one that requires less time and material to be printed, but it will be the one with the worst final finish

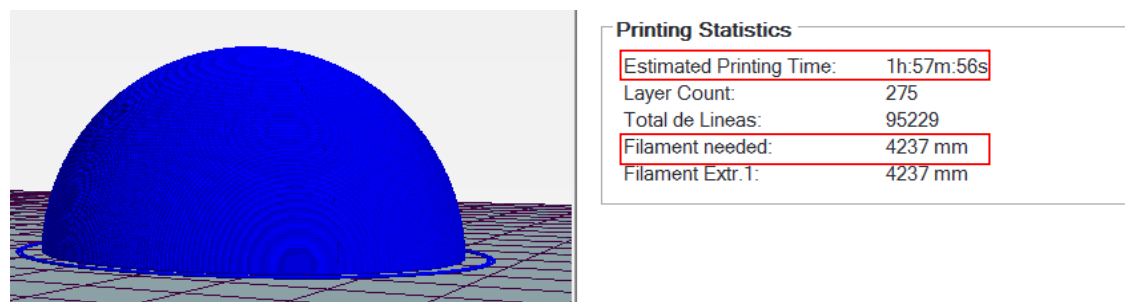

FIGURE 2.1.3.3 Program of hemisphere

Figure 2.1.3.3 is a hemisphere. To generate the physical sphere, this model should be printed twice and the 2 pieces should be joined together. In the program only 1 hemisphere is printed each time to eliminate final finishing errors and to reduce the travel time without printing from one hemisphere to the other. This sphere would be the one which requires more material

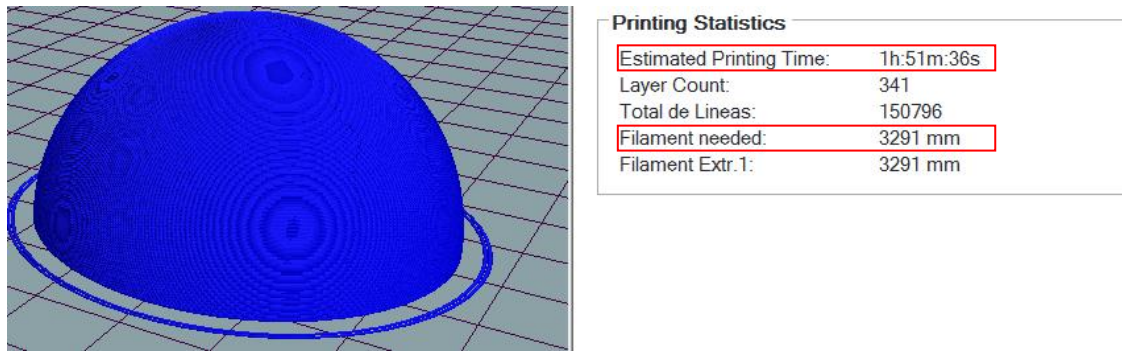

FIGURE 2.1.3.4 Program of empty hemisphere

Figure 2.1.3.4 is an empty hemisphere with supports generated by the slicer. These supports can also be generated manually as mentioned above or with a tool called “Mesh-mixer” of Autodesk. This sphere needs the same post-processing as the previous sphere with the elimination of the internal supports. This sphere consumes more time to be made but it is the lightest one.

Depending on the needs of the prototype, a method will be selected. If fast manufacturing is required, the sphere will be used. If a better finish is required, the hemisphere will be selected. If a finish similar to that of the hemisphere is required but the cost of plastic is reduced and the manufacturing time is increased, the empty hemisphere will be selected.

2.1.4 Print of the Model

The program generated will be sent to the RP machine. These machines are virtually autonomous and do not need human assistance during the print. Only human assistance is needed to turn the machine on, select the file to be printed and to remove the physical prototype from the base.

The programs generated were saved in an SD and printed on an FDM printer model "Ultimaker 2+". Only the results of the sphere file will be shown as they are the most interesting to be analyzed.



PICTURE 2.1.4.1 Sphere printed

Picture 2.1.4.1 shows the result of the impression of the sphere. The support shown in the picture will be removed in the post-processing. The time of printing is the same as the estimate time of the slicer. The picture shows that there were no errors in the printing. Moreover, the bottom of the sphere should be studied because it will need post-processing.

2.1.5 Post-processing

In post-processing, the physical model is removed from the base and supports are removed too. Depending on the RP technology used for printing the prototype, more post-processing will be necessary such as sanding, applying a sealer sanding layer, painting, machining or even applying a heat treatment.

The post-processing of the sphere will consist in separating the sphere from the base and from the supports that have been used. It can be observed that the areas in contact with the supports have a poor superficial finish. The affected areas should be sanded to be improved. The post-processing of the hemisphere will consist in separating the hemisphere from the base and gluing the other hemisphere in order to generate the sphere.



PICTURE 2.1.5.1 Bottom of the sphere

Picture 2.1.5.1 shows the bottom of the sphere, it can be seen that marks remain due to the contact of the supports with the sphere. In addition, the roughness of the area in contact with the supports and subsequent layers is not correct.

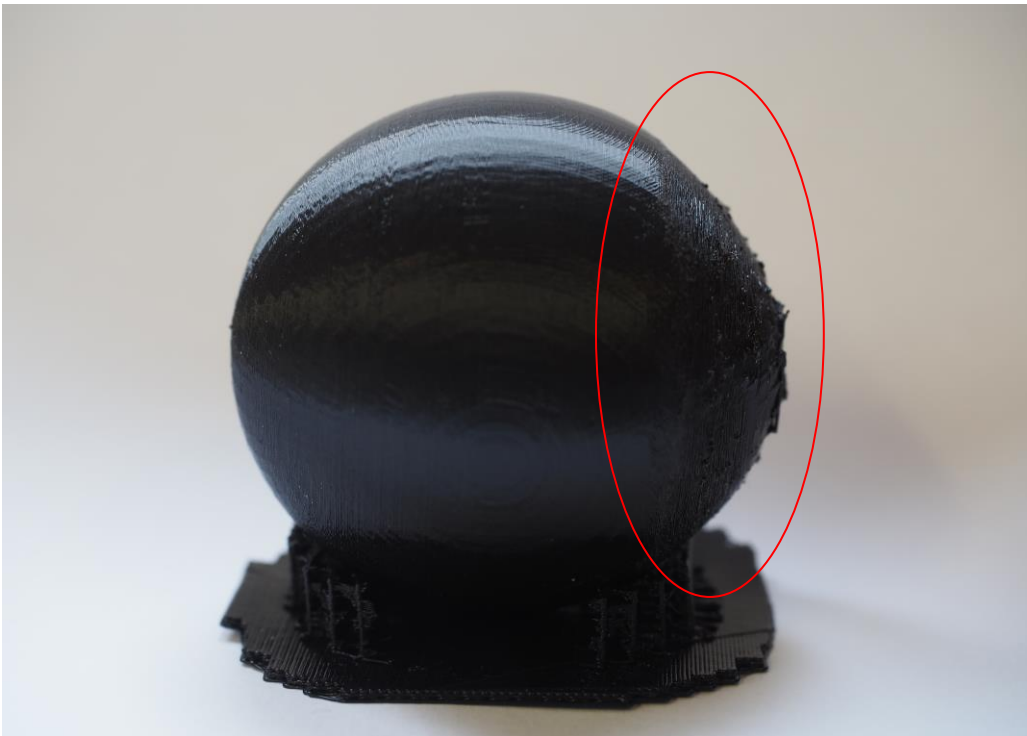

PICTURE 2.1.5.2 Difference of bottom and top of the sphere

Picture 2.1.5.2 marks the area where the supports were necessary. In this case, supports were necessary when there was an overhang threshold of less than 40%. These values are provided by the manufacturer of the machine.

2.1.1 Observations

The example of the sphere shows that the same object can be manufactured from different methods using the same RP technology but no method is more correct than the other. The chosen option of the available tools must be always the one that requires the needs of the prototype. In this example, only FDM technology has been used. But if more techniques were applied, more options would appear, taking into account their advantages and disadvantages.

The engineer who is programming and deciding how to produce the object must have a high level of knowledge of the programs and techniques used. If the engineer does not know it, the final result of the object will be surely the unwanted one.

3 ADDITIVE LAYER MANUFACTURING TECHNIQUES

3.1 Stereolithography

SL machines use an ultraviolet (UV) laser or a projector to cure liquid photopolymer (resin) into hardened plastic. SL machines have a tank containing the resin. The UV laser cures the first layer into the platform; the first layer is support and makes a surface that sticks into the platform. When the layer is finished, the platform descends a distance equal to the thickness of a layer and the sweeper sweeps across the surface of the liquid in the tank to recoat with fresh material. This process will be repeated consecutively, adding a layer on top of the last layer built until the model is finished. (Bournias Varotsis, 3DHubs) (Bártolo Jorge, 2011)

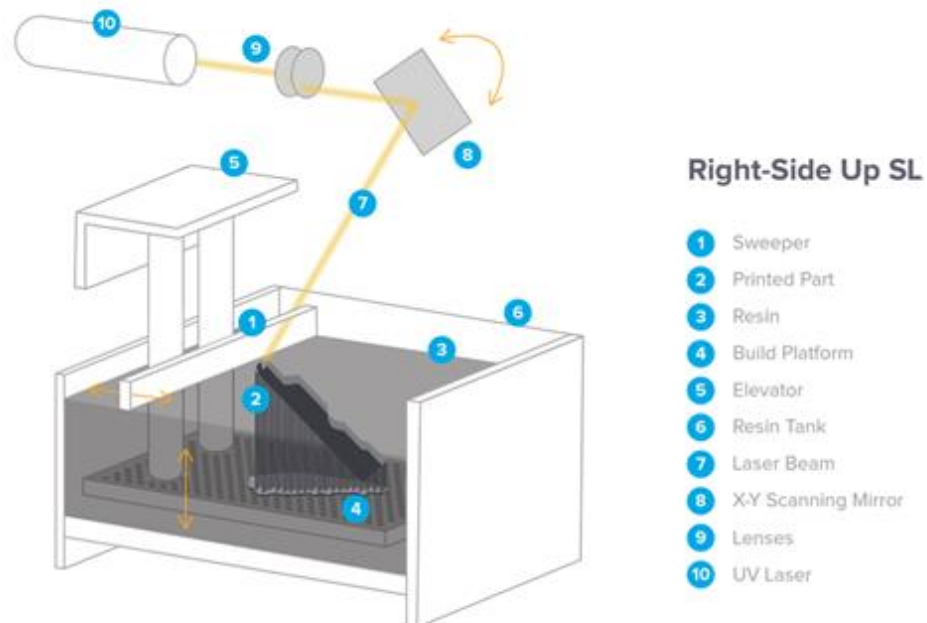

FIGURE 3.1.1 Right-Side Up SL machine (Formlabs)

Figure 3.1.1 is the basic representation of the most common SL machine. Titled Right-Side Up SL machine because this machine has a very large volume and the initial investment to fill the entire tank with resin is high. For these reasons, a variant of these machines appears.



FIGURE 3.1.2 Inverted SL machine (Formlabs)

Figure 3.1.2 is the basic representation of the most common inverted SL machine. The main operation of this kind of machines is the same as those mentioned above. The only difference is the platform which is inverted and the tank, on the bottom, is transparent to allow the UV light of the laser to cure the layer. (Formlabs)

An advantage of this upside-down approach is that the built volume can exceed the volume of the tank substantially, since the machine only requires enough material to keep the bottom of the built vat continuously covered with liquid. This makes the machine generally easier to be maintained, to be cleaned and to swap materials. It also allows a machine with a much smaller size and a lower cost. The SL machine is so small that may be taken to an office room.

The inverted SL has its own set of limitations. When the print is separate from the surface of the tank is affected to the peel forces. The built volume is limited, and larger support structures are required to keep the build platform attached to the print. Peel forces also limit the use of more flexible materials.

Both SL systems require support structures depending on the design and the orientation of the model on the base. In Right-Side Up systems, the supports are generated to secure

that all the parts have an amount of points to be supported. Inverted SL systems use supports to prevent the deflection that could cause the gravity and retain newly created process. The necessary supports in this system are larger.



FIGURE 3.1.3 Comparison of Right-Side Up SL with Inverted SL (Formlabs)

Figure 3.1.3 compares the different supports generated by the two machines. Object A is printed with the inverted SL machine. The generated supports of object A are much more robust and numerous than those of object B. Object B is printed on a Right-Side Up SL machine.

The materials used in the SL technology is liquid photopolymer (resin). There is a list of the most commonly used resins below. It must be taken into account that there are more resins for prototypes with special needs, but these resins will have a high price. (3DSsystems, 2018) (Bártolo Jorge, 2011)

1. ABS (Acrylonitrile butadiene styrene).
Rigid and strong plastic to simulate and replace the machined CNC. Functional assemblies. Short run production parts.
2. PP (Polypropylene).
Flexible plastic. Snap fit assemblies. Master patterns for vacuum casting. Durable functional prototypes.

3. PC (Polycarbonates).
Clear and transparent. Rigid and strong. Great for investment casting patterns.

The SL technology is used to print aesthetic prototypes, therefore all advantages of this technology are very focused on the printing time and the final finish. Here is a detailed list of the advantages of this technology. (Cooper, 2001) (Elanchezhian, Sunder Selwyn, & Shanmuga Sundar, 2007)

1. High speed to produce models, the time of the production depends on the size and complexity of the model.
2. High quality of the surface finish, better than the SLS method.
3. The pieces produced by SL are enough resistant to be machining, and can be used to produce master moulds.

The disadvantages of printing aesthetic prototypes are the poor mechanical properties and the need of post-processing. Here is a detailed list of the disadvantages of this technology.

1. Depending on the complexity of the model, supports will be necessary.
2. If the post-processed is not done correctly, there may be remains of resin in the prototype giving a poor surface finish.
3. The material used tends to be more fragile and less flexible than the material used in the SLS process. In addition, as time goes by, the prototype becomes more fragile because of the environmental UV radiation.
4. The materials used are sensitive to the humidity and the temperature. The sensitivity can be improved with some post-processes.
5. The cost of the SL method is elevated, the minimum price of the machine is around €100,000 and can amount to €400,000, the material varies from €6 to €100. The interest in these technologies is increasing. As a consequence, new more affordable machines are appearing.

3.2 Multi Jet Modelling

MJM is an additive manufacturing process that operates in a similar fashion to 2D printers. In MJM machine, a printhead dispenses droplets of a photosensitive material that is solidifies under UV light, building each part layer-by-layer.

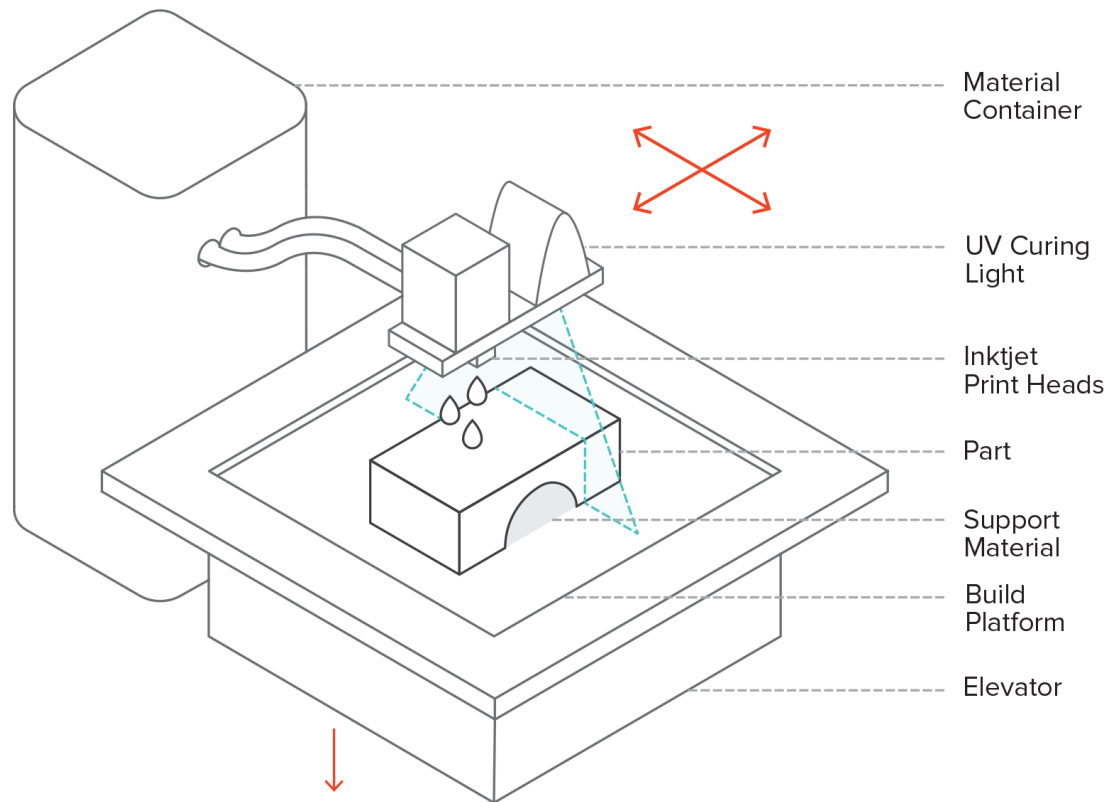

FIGURE 3.2.1 MJM machine (Bournias Varotsis, 3DHubs)

Figure 3.2.1 is the basic representation of the most common MJM machine. The process for printing a prototype consists on heating the material to achieve the optimal viscosity for printing. Small drops of wax like thermoplast are applied in layers by means of multiple print heads arranged in a line. In the direction Y there are all the print heads, for that reason the machine only needs the movement in X. When the layer is finished, UV lamps solidify the model and the supports. Then the platform descends the layer thickness and the process repeats, adding a layer on top of the last built layer until the model is finished. (Bournias Varotsis, 3DHubs) (A. Boboulos, 2010)

Unlike most other 3D printing technologies, MJM deposits material in a line-wise fashion. Multiple inkjet printheads are attached to same the carrier side-by-side and deposit material on the whole print surface in a single pass. This allows different heads to dispense different material. Due to this capacity, multi-material printing, full-color printing and dispensing of dissolvable support structures are commonly used.

Supports are always required in MJM technique. The supports are built in disolable material that can be removed after printing using pressurized water or by immersion in an ultrasonic bath.

MJM technology allows to print with different materials or colours at the same time generating aesthetic prototypes much closer to the final product without post-processing. In order to design particular areas of the part with different material or color, the model must be exported as separate SL files. The multi-material can be employed in 3 different ways: (Bournias Varotsis, 3DHubs)

1. Built area level.
Different heights of the print can be printed using different materials or colours.
2. Section of a part.
Different sections of the heights of the print can be printed using different materials or colours
3. Digital material.
Different materials can be mixed before the print, creating an object with specific physical properties, such as hardness, stiffness or hue.

The materials used in the MJM technology are liquid photopolymer (resin), very similar in mechanical properties with the resins of the SL technology. There is a list of the most commonly used resins below. (3DLabs, 2015)

1. Rigid ABS-like.
This resin simulates the properties of ABS, recommended to manufacture objects with rigidity. The main problem is that ABS-like is brittle.
2. Polypropylene-like.
This resin simulates the properties of polypropylene, it has a good flexure strength. The main problem is that polypropylene-like is brittle.
3. Flexible.
This resin is a rubber-like and can also has a customizable hardness, but it has a poor elongation at break.

The advantages of the MJM technology are very similar to the SL technology because both print the same kind of prototypes. In addition, the printheads of the MJM machine allows faster printing. Here is a detailed list of the advantages of this technology. (Elanchezhian, Sunder Selwyn, & Shanmuga Sundar, 2007)

1. Speed. Building a complex model takes the same time than building a simple model. The main reason is because it only has to move in 2 directions unlike the common RP machines that have 3 axes.
2. MJM can produce smooth parts with surfaces comparable to injection moulding.
3. The objects created have homogeneous mechanical and thermal properties.
4. Due the capacity of multi-material, is it possible to create accurate aesthetical prototypes.
5. No need of post-process

MJM technology and SL technology have similar disadvantages with the added difficulty of multi-material printing. Here is a detailed list of the disadvantages of this technology. (Elanchezhian, Sunder Selwyn, & Shanmuga Sundar, 2007)

1. Poor mechanical properties of the materials, it is only suitable for non-functional prototypes.
2. Rough surfaces on the support material side.
3. In order to design particular areas of the part with different material or color, the model must be exported as separate STL files.
4. The high cost of the technology is not suitable for some applications.

3.3 Fused Deposition Modelling

FDM is based on the extrusion of material and can use a wide variety of materials for the construction of the model and the supports. There is an equivalent term called Fused Filament Fabrication (FFF) coined by the RepRap project to be able to use terminology without legal restrictions. The RepRap Project is an initiative with the intention of creating a self-replicating machine that can be used for RP. This self-replicating machines can produce components of itself. Due to this capacity, the cost of machines is lower and any individual can own it with a small investment. (RepRap, 2018)

The design of these machines can be made in different ways. The most common industrial machine has an extrusion head which moves in the direction X and Y and the built platform descends. This construction is the most stable.

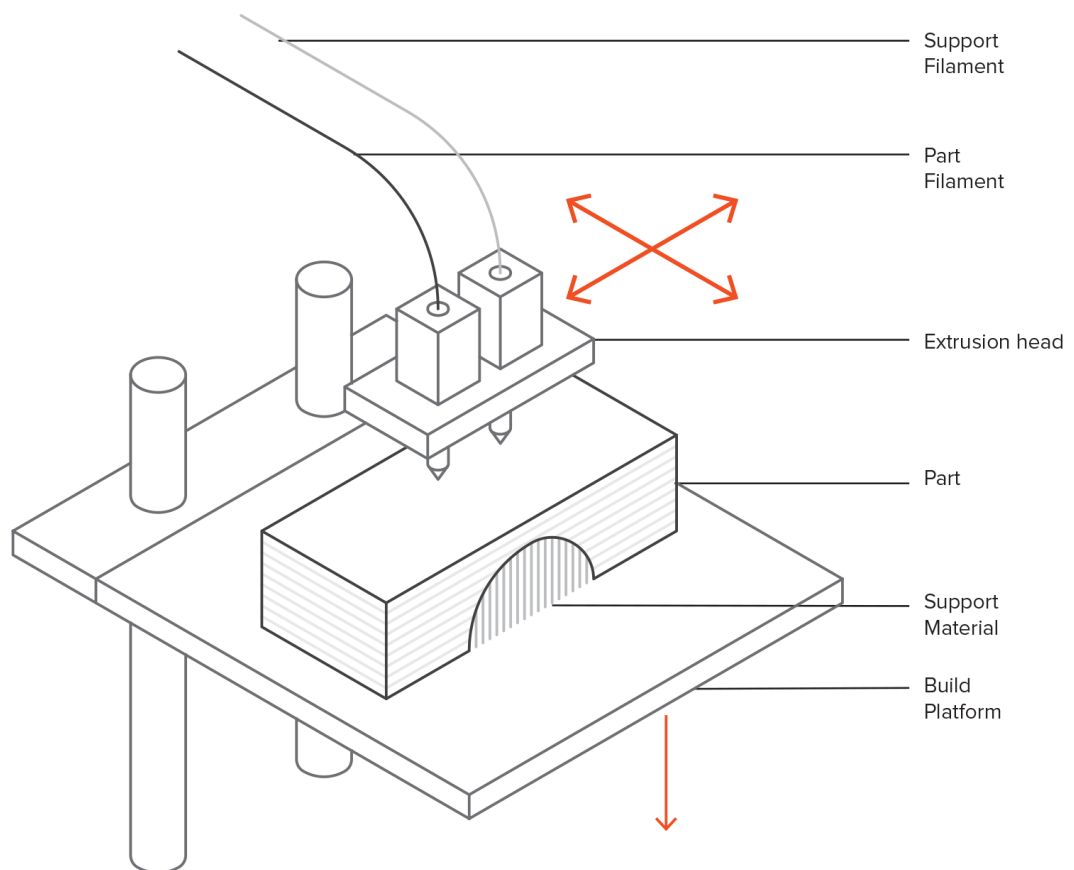

FIGURE 3.3.1 FDM machine (Bournias Varotsis, 3DHUBS)

Figure 3.3.1 is the basic representation of the most common FDM machine. The FDM machines use a filament material and are stored in roll shape. This material is heated to the fusion temperature passing through a nozzle and this material is applied to the last layer built. Then the platform descends the layer thickness and the process repeats, adding a layer on top of the last built layer until the model is finished. The base, depending on the material used, is necessary to be heated to adhere better the material. (CIM UPC) (Bournias Varotsis, 3DHUBS)

The supports in the FDM technology are necessary in the case of overhangs with a larger angle than the manufacturer of the machine ensures that it can work. Small models, or those with small footprints, can sometimes break or detach from the bed. In those cases the supports will also be necessary too. If the object is produced in series with this manufacturing method, the limitations of the machine must be taken into account when it is being modeled in the CAD program. It is important to avoid designs which need to use

an excessive amount of supports. The piece is not designed, the construction of the piece is designed. For this reason, a study must be made to the piece and must remodel the affected parts in order to reduce the angle of the overhangs. When the piece is complex and the supports are necessary, the best option is to invest more time in the CAD model, adding the necessary supports to optimize the process. The supports generated in the slicer to help impressions may have different patterns. These supports will not be optimized for the piece but they are an easy and quick alternative to generate supports. Depending on the geometry and the position of the piece at the time of printing, you must select the most compatible support geometry. In conclusion, the supports in some cases are necessary, but in many cases, they can be reduced or eliminated with intelligent modelling. These intelligent models reduce the need of supports, save material, manufacturing time and post-processing time and improve the final quality of the object. (Upadhyay, Dwivedi, & Kumar Singh, 2017)

The first layer of this technique is the most important. If the first layer is not the best, the manufacturing of the object it could be a failure. The first layer could not stick on the base causing detaching parts and warping. To achieve a good first layer, the base must be well calibrated and the distance must be specified in the slicer with respect to the extruder. If it is necessary, depending on the material, the temperature must be correct. In the first layer, techniques are used to reference and facilitate the printing of the object. Each technique has its advantages and its disadvantages. (Simplify 3D, 2018) (Hodgson, 2018) (Simplify 3D, 2018)

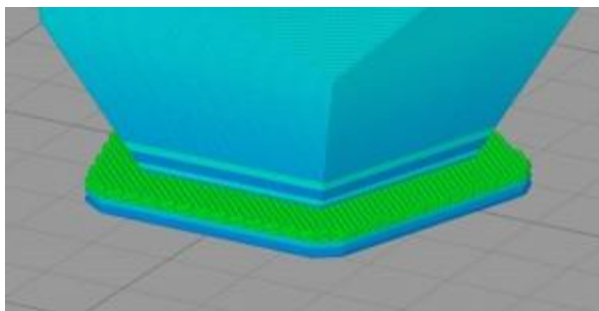

FIGURE 3.3.2 Raft (Simplify 3D, 2018)

A raft is a horizontal latticework of filament that is located underneath the object as shown in Figure 3.3.2. The object will be printed on the top of the raft instead of on the base directly. Rafts are commonly used to the ABS prints to reduce warping and improve the adhesion. In addition, rafts can be used for prints with a small footprint.

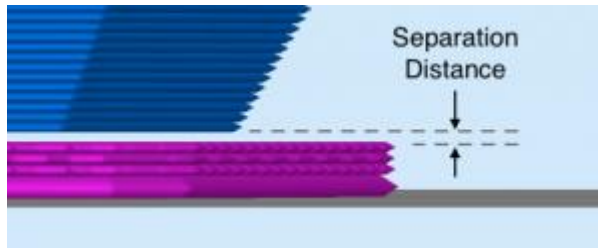

FIGURE 3.3.3 Separation distance of the raft (Simplify 3D, 2018)

As shown in Figure 3.3.3, in order to separate easily the raft from the object, the direction of the filament will not have the same direction of the base of the object. Moreover, the raft will have a separation of the object. In the slicer the value of the distance is necessary to be introduced. This distance cannot be too big since the finish of the base would not be optimal. But the distance cannot be too small since it makes the separation of the raft with the object more difficult.

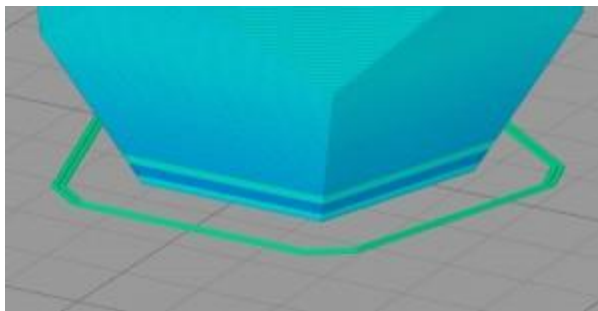

FIGURE 3.3.4 Skirt (Simplify 3D, 2018)

As shown in Figure 3.3.4, a skirt is a line that surrounds the object to be printed, this line has the function of ensuring a uniform and continuous flow of the filament before starting with the object printing. Observing the print of the skirt can also detect if the base is not correctly levelled.

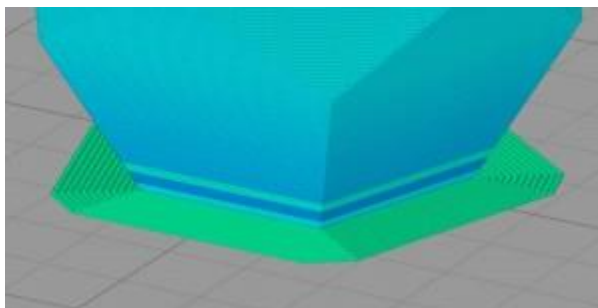

FIGURE 3.3.5 Brim (Simplify 3D, 2018)

As shown in Figure 3.3.5, a brim is considered a skirt which is attached to the object. A brim has the same benefits as the skirt but the surface area of the base increases. This gives a better adhesion of the object to the base and a decrease in warping. This option is used with objects with a small footprint.

All FDM slicers are predefined to have a pattern in the interior of the object. This pattern allows to reduce printing time and save material. The Figure 3.3.4.1 shows the patterns. Each pattern has its advantages and disadvantages. The honeycomb pattern is the most resistant in most of cases, but it is the one which takes the most time to print.

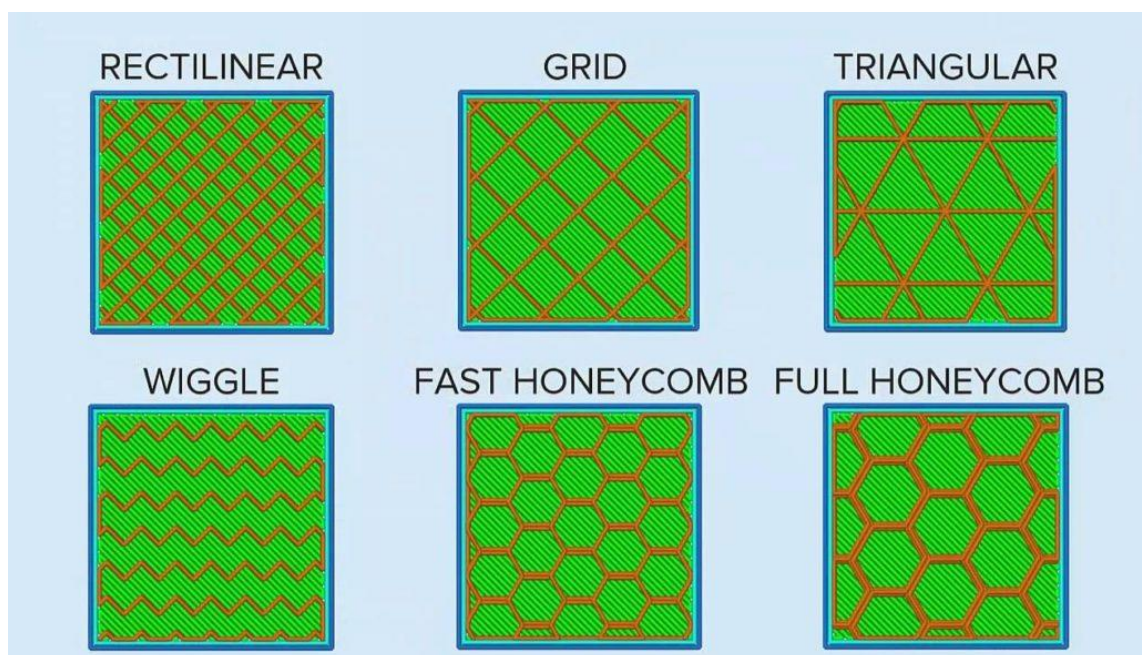

FIGURE 3.3.6 Infill (Simplify 3D, 2018)

Figure 3.3.6 shows the most common patterns of FDM machine impressions. Currently the 3D honeycomb has been developed that makes the pieces more resistant in all directions.

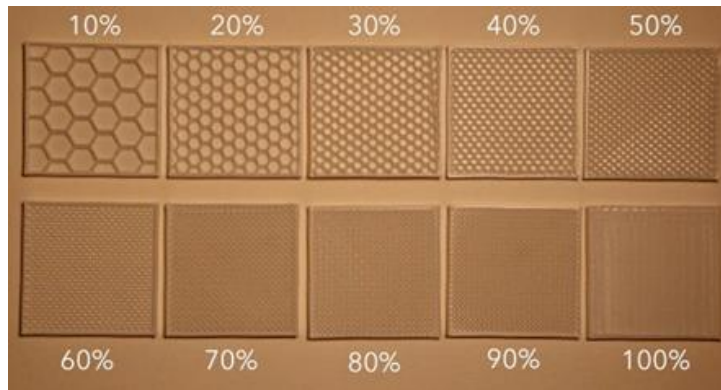

FIGURE 3.3.7 Infill density (Enabling the Future, 2014)

The density of the infill is also a variable to be taken into account. A higher percentage of density increases the strength of the object but it also increases the printing time. Figure 3.3.7 shows the infill difference as a function of the chosen percentage in the slicer.

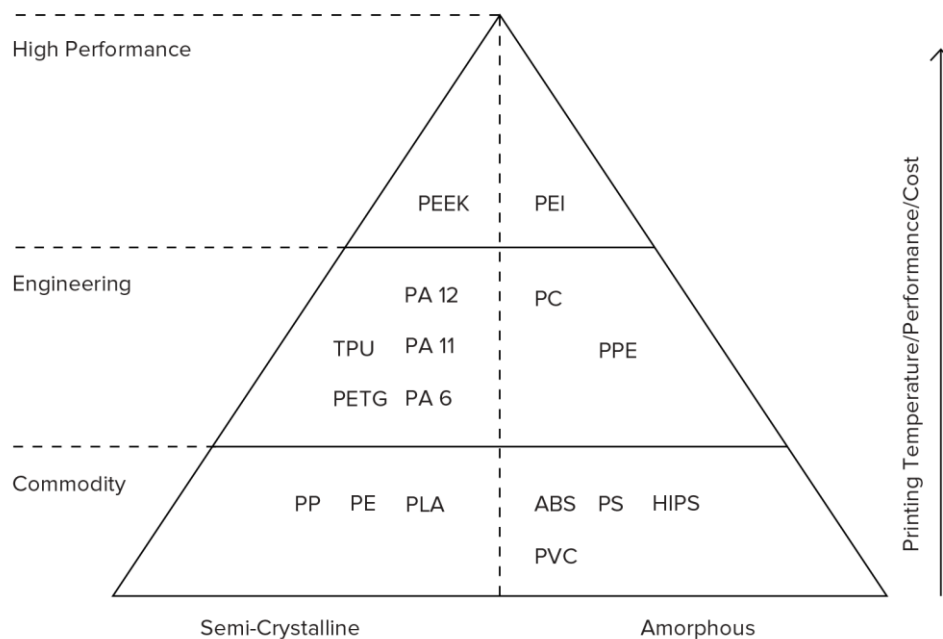

FIGURE 3.3.8 FDM materials (Bournias Varotsis, 3DHUBS)

FDM technology uses plastic. The plastic is a filament that is stored in roll shape. Figure 3.3.8 shows all the plastics used with this technique. Plastics are separated into 3 classes. The plastics of the inferior zone have a low cost and the worst mechanical and thermal properties. The properties improve and the price increases when the plastics are in a higher position in the pyramid. (Bournias Varotsis, 3DHUBS) (BCN 3D) (Simplify, 2018)

The plastics called “commodity” in Figure 3.3.8 are the most common used in desktop printers or to print low cost industrial prototypes without top mechanical and thermal properties. Here is a detailed list of this class of plastics.

1. Acrylonitrile Butadiene Styrene (ABS)
Low cost plastic with good mechanical and thermal properties. Its main disadvantage is the need of a hot base, produces pungent odour and warping in the printing time. It is used for end-use parts or resistant prototypes.
2. High Impact Polystyrene (HIPS)
Plastic with mechanical and thermal properties very similar to ABS, but with a lower weight and soluble in d-Limonene. This is a good support material for ABS or a variant of ABS because it does not produce warping and reduces weight.
3. Polypropylene (PP)
Semi-rigid and lightweight material with a high strength at heat and fatigue. Its price is high and it may generate warping and may not adhere correctly to the base.
4. Polylactic Acid (PLA)
It is a biodegradable polymer, produced from organic sources. It is a material of easy use that is useful in conceptual or aesthetic prototypes, architectural models, moulds to lost PLA or prototypes that do not require high mechanical properties.
5. Composites
Materials based on the above mentioned with carbon fibers, metal powder or wood dust that give a finish similar to the materials added and sometimes the properties of based materials are improved.
6. Polyvinyl Alcohol (PVA)
Material that dissolves in water, making it suitable for supports. Its price is high and airtight storage containers are required.

The materials called “engineering” in Figure 3.3.8 have useful properties but they have more difficulties in storage and printing. They have also a higher price. Here is a detailed list of this class of plastics.

7. Polyethylene Terephthalate Glycol-modified (PETG)
PETG is a Glycol Modified version of Polyethylene Terephthalate (PET), which is used to manufacture water bottles. It is a semi-rigid material with good impact strength, but it has a slightly softer surface which makes easy to be worn away from use. It is ease of printability.
8. Nylon (PA)
Material used commonly in the industry thanks to characteristics like durability, flexibility and strength to corrosion. Nylon filament is hygroscopic, which

means that absorb moisture of the surrounding. Printing Nylon after the absorption of moisture generates several issues. Another disadvantage is that Nylon generates warping.

9. Thermoplastic Polyurethane (TPU)

Flexible and soft plastic. The flexibility depends on the chemical formulation used by the manufacturer. It is difficult to print, generates blobs and stringing.

10. Polycarbonate (PC)

Material that has extremely high heat deflection, impact strength and maintains its structural integrity at 150°C. PC filament is hygroscopic, which means that absorb moisture of the surrounding. Printing PC after the absorption of moisture generates several issues.

The materials called “high performance” in Figure 3.3.8 have the best mechanical, thermal and chemical properties. The main disadvantages of these materials are the high price and the high temperature needed to be printed.

FDM technology is used to print both functional and aesthetic prototypes. The FDM technology can print these two classes due to the facility of the use of the machine and its large catalogue of materials. Here is a detailed list of the advantages of this technology. (Bournias Varotsis, 3DHUBS) (Elanchezhian, Sunder Selwyn, & Shanmuga Sundar, 2007)

1. FDM is the most cost-effective way of producing objects in thermoplastic.
2. Ease of use since the temperature needed in the printing time is not elevated and there is no post-processing.

This machine makes stand out for its versatility because it gives the possibility of printing two kinds of prototypes. But this machine does not make the best prototypes of each class. Here is a detailed list of the disadvantages of this technology.

1. FDM is slower compared to techniques that use lasers, like SL.
2. FDM has the lowest dimensional accuracy, it is not suitable for intricate geometries.
3. Visible lines in FDM prints, for a smooth finish post-processing is required..
4. Poor mechanical properties of materials.

3.3.1 Metal 3D Printing

Atomic Diffusion Additive Manufacturing (ADAM) technique is based in FDM. The ADAM technique use a filament of metal powder bound in plastic to print the object layer by layer. The printed objects scaled up to compensate the process of sintering. The printed parts go through a washing stage to remove some of the binder. Then the print is sintered in a furnace and the metal powder fuses into solid metal and the plastic. The object is only of pure metal, it can be processed and treated like any other metal object manufactured with traditional techniques. ADAM technique is quite new and is not the most common RP technique in metal 3D printing but it is less expensive. (Amed, 2017) (Markforged, 2018)

3.4 Selective Laser Sintering

In SLS, a laser selective sinters the particles of a polymer powder, fusing them together and building a part layer-by-layer. The printing of the prototype consists of heating the powder bin and the built area are just below the melting temperature of the polymer. Then the recoater spreads a thin layer of powder over the built platform. Later, the CO₂ laser scans the contour of the next layer and sinters the powder polymer. Then the laser scans the entire cross section in order to have a solid object. When the layer is finished, the built platform descends the layer height and the recoater spreads a new layer of the powder polymer. When the object is finished, it is encapsulated in the unsintered powder and it has to wait until all the powder is cooled, this can take a considerable amount of time. The parts are cleaned with compressed air. The unsintered powder is collected and can be reused. (Cooper, 2001) (Bournias Varotsis, 3D HUBS) (Nehuen, 2015)

The main disadvantages of the SLS method are the shrinkage, the warping and the over-sintering. The shrinkage is 3-3.5% of the dimensions but the machine operator usually takes this percentage into account. Warping happens when the newly sintered layer cools, its dimensions decrease and internal stresses appear pulling the underlying layer upwards. Oversintering occurs when radiant heat fuses unsintered powder around a feature. This can result in a loss of details in small features, like slots and holes. (Bournias Varotsis, 3D HUBS) (Ghosh, Subrata, & Saha, 2014)

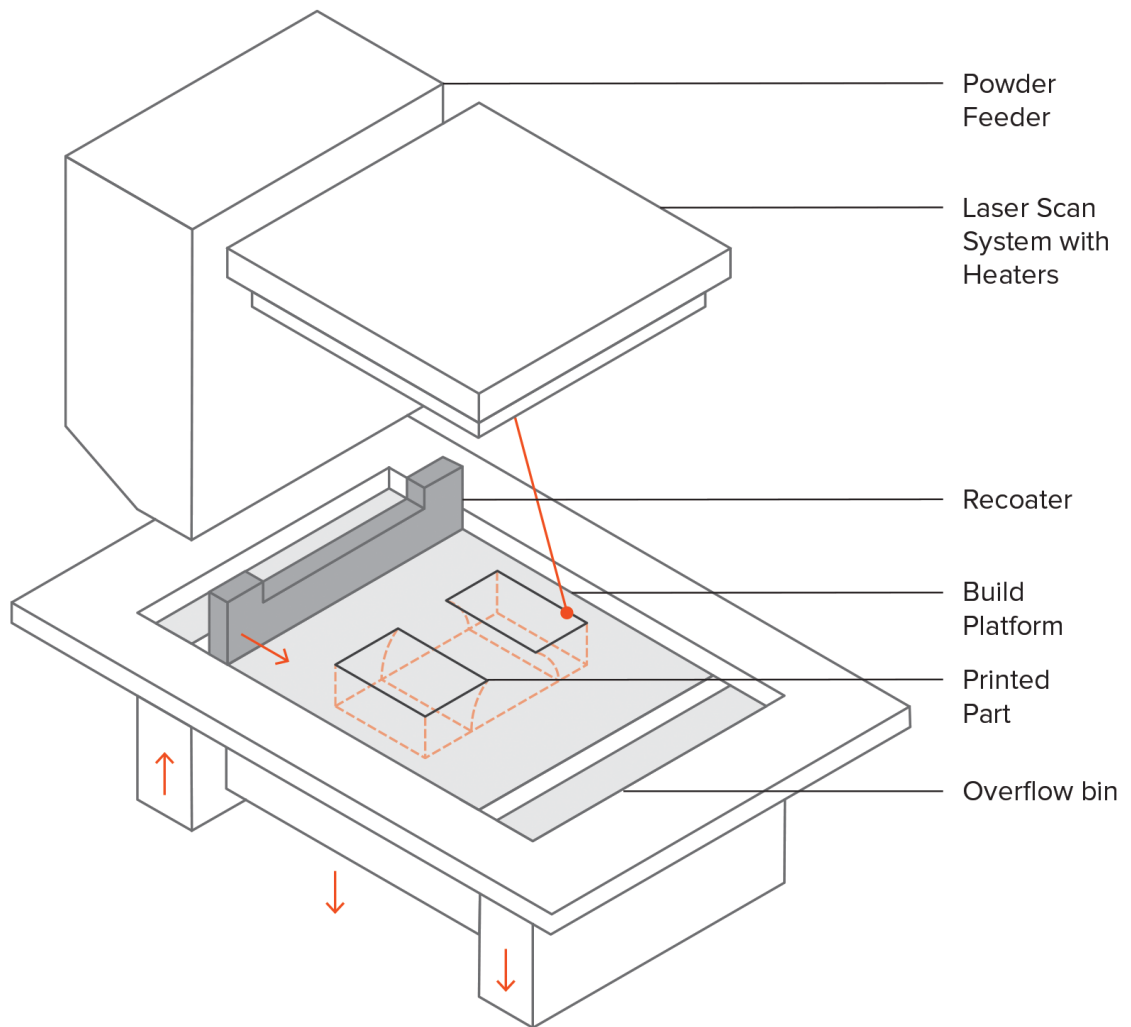

FIGURE 3.4.1 SLS machine (Bournias Varotsis, 3D HUBS)

Figure 3.4.1 is the representation of the most common SLS machine. It can be seen that the powder feeder is over the base. Each time a new layer is applied, the powder feeder feeds the base and the recoater spreads the powder to generate a uniform layer. The remaining powder feeds the overflow bin. The collected powder will be used in the next printing.

The materials used are thermoplastic polymers. The most common material used is PA, also known as Nylon. This Nylon is used alone or with additives that improves some characteristics. The TPU material is also used and it is an appropriate elastomeric with a high tear resistance and shore hardness. It is suitable for durable parts with rubber-like properties. There is a list of the most commonly used Nylon compounds below. (Strasys, 2018)

1. Nylon.
Great mechanical properties and chemical resistance.
2. Carbon filled Nylon.
Contains carbon fibre or graphite that gives parts high stiffness and improves thermal properties over standard Nylon.
3. Glass filled Nylon.
Contains glass particles that give parts high stiffness and improve thermal and abrasion resistance over standard Nylon.
4. Aluminium filled Nylon.
Contains aluminium particles that give parts a metallic appearance, improved stiffness over standard Nylon and have a great machinability.
5. Mineral filled Nylon.
Contains mineral particles that give parts higher stiffness, thermal stability and density over standard Nylon.

The SLS technology is mainly used to print functional prototypes due the joints generated when the powder is sintered. Here is a detailed list of the advantages of this technology. (Elanchezhian, Sunder Selwyn, & Shanmuga Sundar, 2007)

1. Complex geometries can be produced because SLS requires no supports.
2. The objects printed have good mechanical properties, ideal for functional parts or prototypes.
3. No loss of materials for generating supports. The excess powder is reused in another prototype.

The cost and time of printing a prototype is height because SLS works with a large quantity of material and high temperatures. Here is a detailed list of the disadvantages of this technology. (Elanchezhian, Sunder Selwyn, & Shanmuga Sundar, 2007)

1. Long building time, due to the slow speed of the scan and the need of the powder cooling.
2. SLS prototypes have a grainy surface and internal porosity. These could be fixed with post-processing.
3. Large flat surfaces and small holes cannot be manufactured with accuracy because they are susceptible to warping and oversintering.
4. The objects printed needs internal hollow cavities to be perforated in order to drain the unsintered powder material.

3.4.1 Metal 3D Printing

The most commonly used technologies in metal RP are based on the same principles as the SLS. The most useful technologies are Selective Laser Melting (SLM) and Direct Metal Laser Sintering (DMLS), both of them use metal powder that with a laser sinter the powder to print the object. The difference between SLM and DMLS is that SLM produces objects with a single metal powder and it uses this metal powder with a single melting temperature while the DMLS produces objects with mixed alloy metal and it uses powders with different melting temperatures.

The main difference of the SLS process is at the start of printing. The SLS process uses a chamber which is filled with an inert gas, commonly argon, to minimize oxidation of the metal. The supports in the printing are also necessary to assure the accuracy in the curing process and to maintain the tolerance and shape of delicate parts. Moreover, some parts can also experience melt deformation when delicate parts are left unsupported because metals are being melted at extremely high temperatures.

Metal 3D printers can manufacture complex geometries that are complicated to be produced with traditional technologies. Metal 3D printers can also optimize the weight and the alloy of the objects. Otherwise, metal 3D printers are complex, expensive and have a limited built size. For these reasons, the designs optimized by traditional techniques are not suitable in metal 3D printing.

3.5 Laminated-Object Modelling

In LOM, the most common material is laminated paper sheet. The sheet is cut by a laser, heated and compressed to generate the object. LOM is commonly used to manufacture scaled models or conceptual prototypes.

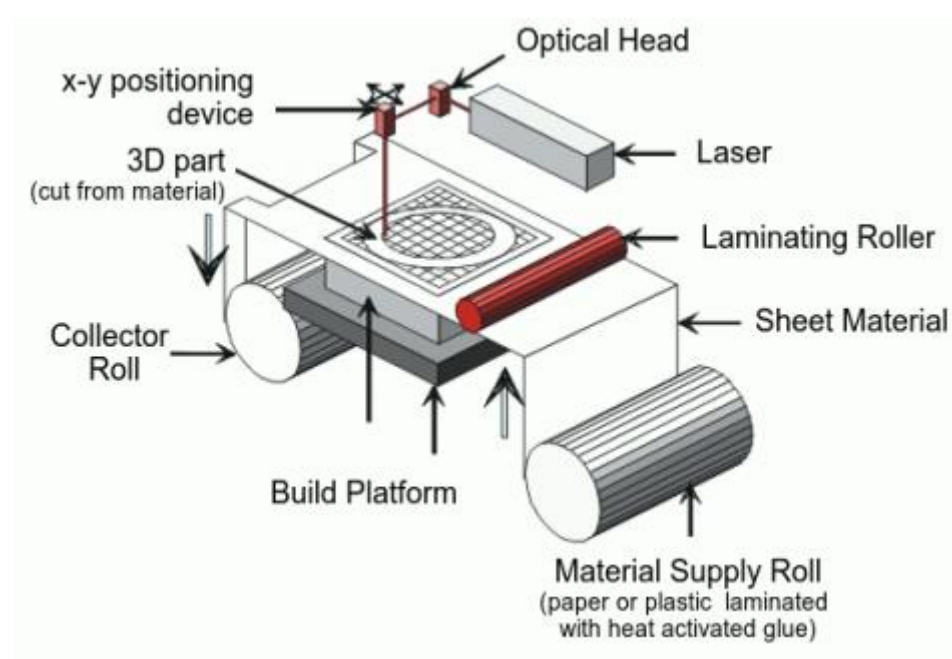

FIGURE 3.5.1 LOM machine (Scan and Make)

Figure 3.5.1 is the common design of LOM machine. The material used is supplied with a roll. The width of the sheet is bigger than the maximum dimension of the object, the enclosure area needs margins. This is necessary in order to have a useful collector roll and a continuous and fast LOM process. When the first layer of the sheet material is deposited on the built platform, the laminating heated roll compresses and heats the layer to be stuck with the last layer. Then the laser cuts the 2D form of the object, the cross-hatched cubes and the supports walls. After the cut of the laser, the built platform descends the height of the sheet and the roller supplies the size of the paper needed. When the print is finished, the object is encapsulated and it needs the post processing of removing the excess of material. (Chua, Leong, & Lim, 2010)

Commonly, the first 5 to 10 layers are added before the printing in order to protect the object when is removed from the built platform and to check if the parameters used in the slicer are correct.

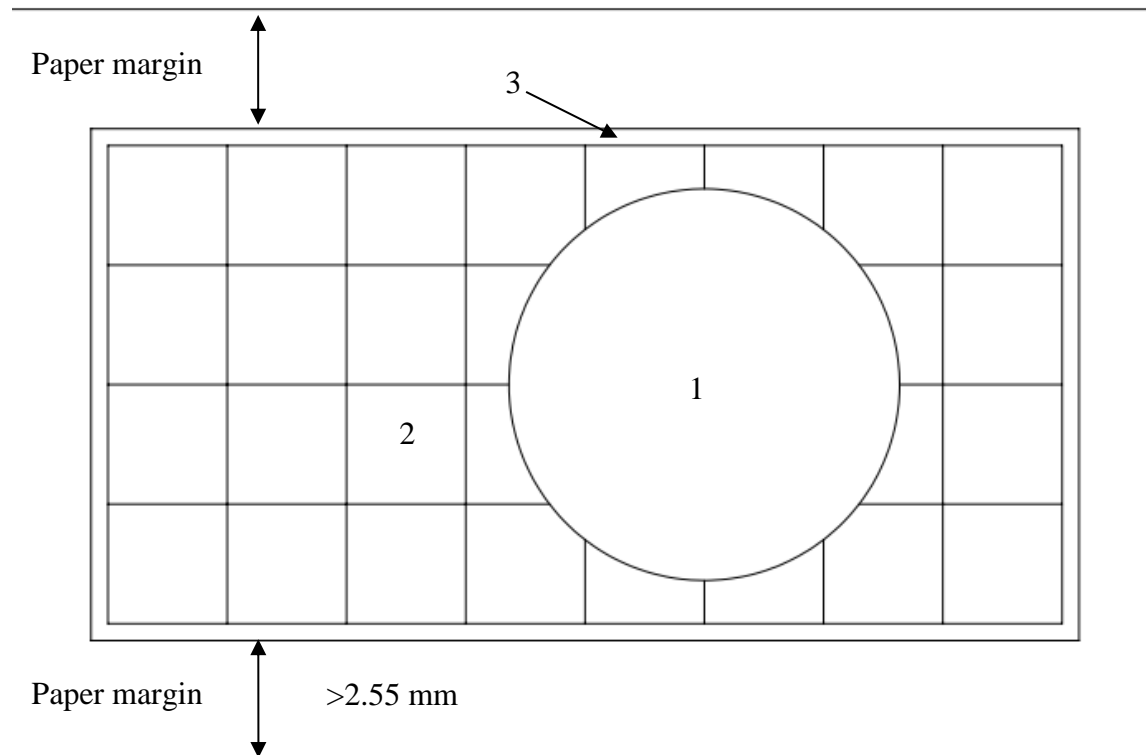

FIGURE 3.5.2 Cut sheet of LOM

Figure 3.5.2 is the representation of a layer using the LOM technique. In this layer, the laser cuts the 3 parts needed. Here is a list of the 3 parts mentioned above and based on the previous figure. (Elanchezhian, Sunder Selwyn, & Shanmuga Sundar, 2007)

1. Object.
2D section of the object printed.
2. Crosshatches cubes.
Sections of paper that is no needed and they make cutting easier to remove the unused material in post process. It is important to consider that the small size of the crosshatches makes easier to remove it from small walls of the object but increase the time of cutting.
3. Support wall.
Wall that encloses the object and the crosshatched cubes so that they remain together and maintain stability in the impression.

The figure is no optimized because there are too many numbers of crosshatches cubes. Always try to reduce the number of cubes in order to minimize the amount of unused material. The most common option is adding more objects, but you can also do a study of the position of the object to be printed.

When the printing is finished, the cube containing the prototype is extracted. The post-processing consists of first, the base of 5 to 10 layers printed is placed up and removed with a wood chisel or a similar tool. When the bottom of the object is revealed, first the support wall can be removed and later the crosshatches cubes fall. The crosshatches cubes must be removed from the delicate areas with the fingers. It must be done carefully in order to avoid damaging the object. (Elanchezhian, Sunder Selwyn, & Shanmuga Sundar, 2007)

When the object is manufactured of paper sheet is necessary to apply wood sanding sealer to prevent the object from absorbing moisture. The absorption of moisture can generate distortion or delamination. The sanding sealer generates a layer that can be sanded or polished for a nice finish. Finally the object can be painted. (Palermo, 2013)

The materials must be always rolls of laminated material. The most common material in LOM is paper. All the papers have the same hardness (55-70 ShoreD), the main difference between the papers are the tensile strength, the elastic modulus and the elongation when a force is applied.

Sheets of plastic are also used, but are not commonly. The main differences between the papers and sheet of plastic is that plastic is not affected by the moisture and the tensile strength is improved.

LOM technology is used to print aesthetic prototypes because this technology has a great accuracy with the final product. However, the materials used do not have appropriate mechanical properties. Here is a detailed list of the advantages of this technology. (Cooper, 2001)

1. Support structures are no needed in LOM.
2. Materials and equipments are inexpensive.
3. Easy process and maintenance.
4. Good accuracy in large objects.
5. Fast time in process.

LOM technology normally uses paper for printing. Paper is a very cheap material with some production risk that other technologies do not have. Also, time is wasted because

the post-processing is not automated. Here is a detailed list of the disadvantages of this technology.

1. Long time of post-processing removing the crosshatches cubes, taking into account that LOM is an automated process.
2. Waste of material in the crosshatches cubes.
3. Produce smokes and fumes in the printing.
4. The cutting machine works burning the paper. The operator has to keep in mind that there is a fire hazard.
5. Not ideal to make complex geometries.
6. Functional prototypes cannot be manufactured.

4 3D SCANNER

3D scanners are not RP machines, but they combine perfectly with the RP machines. 3D scanner scans the surface of the objects to collect data points in the space and sometimes the colour of the surface. With those data points, the program of the 3D scanner generates all the surfaces scanned. 3D scanners have different ways to collect the data points. There are 2 big categories, contact and non-contact. (Boehler, Heinz, & Marbs, 2001)

Contact scanners collect the data points touching the surface of the object. With internal sensors of the scanner, the controller program touches the surface and knows the position of the point. These contact scanners are slower than non-contact scanners and can damage the object scanned. (Carbone, Carocci, Savio, Sansoni, & De Chiffre, 2001)

The non-contact scanners capture the geometry of the object thanks to some kind of signal emitted by the scanner or by the environment. Non-contact scanners do not damage the scanned object because the signals that are commonly used are lights. Non-contact techniques can be subdivided in active and passive.

Active scanners emit some kind of signals. The 3D scanner can collect the geometry of the object with a variety of signals. There is a list of the most commonly used active 3D scanners below. (Boehler, Heinz, & Marbs, 2001)

1. Triangulation.

Using the same principle of the triangulation in trigonometry, the scanner uses a laser to emit a beam that falls upon the surface of the object. When the beam is received by the camera, the triangle is closed, and the position in the space of the scanned point is known. The precision of this scanner could be high but this depends on the angle of the laser and the camera. For that reason, the scanned area is usually 30cm. Due to the disadvantage of the scanned area, the hand-held triangulation scanners appear. With hand-held scanners, the use of references (commonly adhesive reflective tabs) is necessary to position the scanner since it is always in movement.

2. Structured light.

This method projects a light pattern on the object and analyses the deformation of the pattern produced by the geometry of the object. This deformation analysis works with the same principle as triangulation, but structured light analyses the whole light pattern. This pattern of lights can be from a simple line to a grid or a

trim of geometry. This method is faster than the triangulation because it can analyze multiple points at the same time. But structured light does not have the same great precision as the triangulation.

The passive scanners do not emit some any kind of signal otherwise detect the signals that provide the ambient, commonly the ambient radiation reflected in the object. These methods are inexpensively compared with the active scanners because commonly there is no need of special machines, only digital cameras. These methods are not as precise as active methods but they give more aesthetic model using colours. There is a list of the most commonly used passive 3D scanners below. (Singh Verma & Wu, 2015)

1. Stereoscopic.
System of 2 separated cameras looking at the same object. Making a comparison between the differences of the 2 images taken and the distance of each point is determined. This method is based in the vision of the humans.
2. Photometric.
This system only uses 1 camera but it has to take several images. With all the images, the shapes are mixed to recreate an approximation of the object. With this method, changing the initial conditions of the scan, for example the light and the position of the object, is forbidden.

There are 2 main applications of the 3D scanners in the industry, reverse engineering and dimensional control. 3D scanners allow to perform these processes much faster than traditional processes because 3D scanners are easy to use and have high precision.

Reverse engineering has the objective of obtaining information of the studied object with the 3D scanner. The information that is possible to obtain is the design. With the 3D scanner, the scanned object is represented with a polygonal mesh. With specialized programs, the mesh is converted into a solid CAD model. Compared to the traditional method of measuring and drawing in the CAD program, the scanners have a great advantage due to the precision and the speed of obtaining the 3D CAD model. (Boehler, Heinz, & Marbs, 2001)

Reverse engineering is not only for new products, it can also be used for old products that are no longer manufactured and their plans are outdated or lost. With the use of the 3D scanners and the 3D metal printers, old parts can be replaced reducing their manufacturing cost, because they do not need to be machined.

In the case of dimensional control, with the development of the industries, the margins of the tolerances are reduced and are needed a rapid control of tolerance. With the precision of 3D scanners, the scanned object generates the points in the space. These points are compared with the 3D CAD model, allowing meticulous control.

5 Practical Case: Scan of the Boat for ACOLOR project

ACOLOR is a project which will develop autonomous and collaborative capabilities between an aerial, underwater vehicle and surface vessel. This project uses communications and connectivity to of all the vehicles in order to have obstacle detection and path planning.



Picture 5.1 ACOLOR boat (Escusol Villa, 2018)

The project uses the boat of the Picture 5.1 as central to all autonomous vehicles. This boat will also be autonomous. In order for the ship to be autonomous, all the structures will have to be remodelled.

The problem comes up because there is not a 3D model in CAD format of the boat. The team cannot assemble the pieces designed and they cannot verify that all pieces fit. Since remodelling the whole measuring boat is a difficult task, the team decides to scan the ship in 3D.



PICTURE 5.2 “HandySCAN 700” made by Creaform (Creaform)

The scanner of this project is a hand-held scanner called “HandySCAN 700” made by Creaform shown in Picture 5.2, using the technology of triangulation. Table 5.1 shows the technical specifications of the scanner. These specifications are important to be taken into account when the boat is scanned.

TABLE 5.1 Technical specifications of HandySCAN 700 (Creaform)

Scanning area	275 x 250 mm
Accuracy	Up to 0.030 mm
Volumetric accuracy	0.020 mm + 0.060 mm/m
Part size range (recommended)	0.1 – 4 m
Stand-off distance	300 mm
Depth of field	250 mm
Software	VXelements

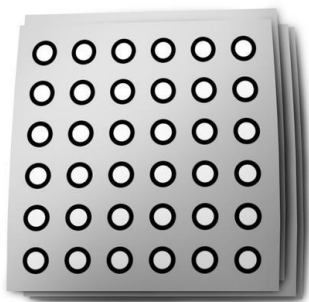

PICTURE 5.3 Positioning targets (Proto 3000)

As it is mentioned before, the references used in this project are positioning targets shown in Picture 5.2. These positioning targets are reflective and are positioned randomly.

6 CONCLUSIONS & DISCUSSIONS

In the theoretical content of RP, the process from modelling to post-processing of additive manufacturing techniques is explained. The importance of each of the phases was transmitted. Personally, I would have liked to include an optimization guide of modelling prototypes and supports for printing in additive manufacturing techniques.

The theoretical content of the additive manufacturing explains the process of printing and materials of the most commonly used techniques in the industry. It is also explained the advantages and disadvantages of each process, what kind of prototypes is printed, what kind of supports is needed and the necessary post-processing. I consider this guide as a base to start into this field. I would have liked to include an explanation of the slicers and how to use them. Moreover, I would have liked to give more importance to the RepRap community and its achievements.

The theoretical content of the 3D scanners explains the most important scanners of today and their applications. These tools are more difficult to find the information because they are much more innovative than rapid prototyping. Even with the added difficulty a basic guide was created.

After the scanning of the boat, the main objectives were partially achieved. Due to the size of the boat, the interior of one half of the boat was only possible to scan. All the inside was modelled with the post-processing. Even with only the partial scan of the ship, a post-processing guide for large objects was possible to be made. In the future TAMK students could use other scanners to be able to compare the results and decide which scanner is the best for each project.

In conclusion, the main objectives of the thesis were achieved. In the future, this thesis could be expanded by other TAMK students with the aforementioned sections in order to obtain a complete guide in RP and 3D scanners.

REFERENCES

- 3DLabs*. (2015). Retrieved March 04, 2018, from Web of 3DLabs: <http://3dlabs.de/mjm/?lang=en>
- 3DSystems*. (2018). Retrieved February 20, 2018, from Web of 3DSystems: <https://es.3dsystems.com/on-demand-manufacturing/stereolithography-sla/materials>
- A. Boboulos, M. (2010). *CAD-CAM & Rapid prototyping Application Evaluation*. Ventus .
- Amed, R. (2017, February 17). *3D Printing*. Retrieved April 20, 2018, from Web of 3D Printing: <https://3dprinting.com/metal/atomic-diffusion-additive-manufacturing-game-changer/>
- Bártolo Jorge, P. (2011). *Stereolithography*. Boston: Springer.
- BCN 3D*. (n.d.). Retrieved March 10, 2018, from Catalog of Material: <https://www.bcn3dtechnologies.com/en/3d-printer/filaments/>
- BCN3D* . (n.d.). Retrieved March 10, 2018, from Web of BCN3D Technologies: <https://www.bcn3dtechnologies.com/en/tecnologias/>
- Boehler, W., Heinz, G., & Marbs, A. (2001). *THE POTENTIAL OF NON-CONTACT CLOSE RANGE LASER SCANNERS FOR CULTURAL HERITAGE RECORDING*. Mainz.
- Bournias Varotsis, A. (n.d.). *3D HUBS*. Retrieved March 25, 2018, from Web of 3D Hubs of SLS: <https://www.3dhubs.com/knowledge-base/introduction-sls-3d-printing>
- Bournias Varotsis, A. (n.d.). *3DHubs*. Retrieved March 14, 2018, from Web of 3DHUBS of Material Jetting: <https://www.3dhubs.com/knowledge-base/introduction-material-jetting-3d-printing>
- Bournias Varotsis, A. (n.d.). *3DHubs*. Retrieved February 21, 2018, from Web of 3DHUBS of SLA: <https://www.3dhubs.com/knowledge-base/introduction-sla-3d-printing>
- Bournias Varotsis, A. (n.d.). *3DHUBS*. Retrieved March 01, 2018, from Web of 3DHubs of FDM: <https://www.3dhubs.com/knowledge-base/introduction-fdm-3d-printing>
- Carbone, V., Carocci, M., Savio, E., Sansoni, G., & De Chiffre, L. (2001). Combination of a Vision System and a Coordinate Measuring Machine for the Reverse Engineering of Freeform Surfaces. *The International Journal of Advanced Manufacturing Technology*, 263–271.

- Chua, C. K., Leong, K. F., & Lim, C. S. (2010). *Rapid Prototyping : Principles and Applications* (3 ed.). New Jersey: World Scientific Publishing.
- CIM UPC. (n.d.). Retrieved March 08, 2018, from Web of Fundació CIM: <https://fundaciocim.org/ca/fabricacio/fabricacio-additiva>
- Cooper, K. G. (2001). *Rapid Prototyping Technology*. New York: Marcel Dekker.
- Creaform. (n.d.). Retrieved April 15, 2018, from Portable 3D scanners: HandySCAN 3D: <https://www.creaform3d.com/en/metrology-solutions/portable-3d-scanner-handyscan-3d>
- Elanchezhian, C., Sunder Selwyn, T., & Shanmuga Sundar, G. (2007). *Computer Aided Manufacturing* (Second ed.). New Delhi; Boston: Laxmi.
- Enabling the Future*. (2014, November 13). Retrieved March 11, 2018, from Web of Enabling the Future: <http://enablingthefuture.org/2014/11/13/tech-talk-thursday-intro-to-3d-printing/>
- Escusol Villa, J. (2018, January 31). *Tech Finland*. Retrieved March 30, 2018, from Kategoria: Autonomous and Collaborative Offshore Robotics (aCOLOR): <http://techfinland100.fi/category/autonomous-and-collaborative-offshore-robotics-acolor/>
- Formlabs. (n.d.). *Formlabs*. Retrieved February 25, 2018, from Web of Formlabs: <https://www.3dhubs.com/knowledge-base/introduction-sla-3d-printing>
- Gabriel Sebastian, L. (n.d.). *Linus Tech Tips*. Retrieved April 29, 2018, from Web of Linustechtips: <https://linustechtips.com/main/>
- Gebhardt, A. (2003). *Rapid Prototyping*. Munich: Hanser.
- Ghosh, K., Subrata, K. D., & Saha, P. (2014). Selective Laser Sintering: A Case Study of Tungsten Carbide and Cobalt Powder Sintering by Pulsed Nd:YAG Laser. In S. N. Joshi, & U. Shanker Dixit, *Lasers Based Manufacturing : 5th International and 26th All India Manufacturing Technology, Design and Research Conference* (p. 426). New Delhi: Springer India.
- Hodgson, G. (2018). *Slic3r*. Retrieved March 15, 2018, from Manual Slic3r: <http://manual.slic3r.org/expert-mode/skirt>
- Hudson, B. (2018). *3D Hubs*. Retrieved February 20, 2018, from Web of 3D Hubs: <https://www.3dhubs.com/knowledge-base/how-design-parts-fdm-3d-printing>
- K. Kamrani, A., & Abouel Nasr, E. (2010). *Engineering Design and Rapid Prototyping*. Boston: Springer.

- Komin*. (2017, October 24). Retrieved May 2, 2018, from Web of Komin: <https://www.komin.com.co/single-post/2017/10/24/%C2%BFCu%C3%A1les-son-las-clases-de-modelos-y-prototipos>
- Markforged*. (2018). Retrieved April 20, 2018, from Web of Markforged: <https://markforged.com/metal-x/>
- Nehuen, A. (2015, December 9). *Sculpteo*. Retrieved March 23, 2018, from Web of Sculpteo: <https://www.sculpteo.com/blog/2015/12/09/3d-printing-technologies-sls-sla/>
- Palermo, E. (2013, October 09). *Live Science*. Retrieved March 29, 2018, from What is Laminated Object Manufacturing?: <https://www.livescience.com/40310-laminated-object-manufacturing.html>
- Proto 3000*. (n.d.). Retrieved April 15, 2018, from Coded Targets, adhesive, 8 mm, #241-447 for HandyPROBE 780: <https://store.proto3000.com/collections/3d-scanning/products/coded-targets-adhesive-8-mm-241-447-for-handyprobe-780>
- Průša, J. (2017, March 11). *Prusa Printers*. Retrieved March 20, 2018, from Web of Prusa Printers: <https://www.prusaprinters.org/smooth-variable-layer-height-awesome-supports-slic3r-prusa-edition/>
- RepRap*. (2018, January 10). Retrieved March 01, 2018, from Web of RepRap: <http://reprap.org/>
- Scan and Make*. (n.d.). Retrieved March 30, 2018, from Additive Manufacturing: <https://scanandmake.com/additive-manufacturing>
- Simplify*. (2018). Retrieved March 15, 2018, from Materials of Simplify: <https://www.simplify3d.com/support/materials-guide/>
- Simplify 3D*. (2018). Retrieved March 15, 2018, from Web of Simplify3D: <https://www.simplify3d.com/support/articles/rafts-skirts-and-brims/>
- Singh Verma, C., & Wu, M.-J. (2015). *Photometric Stereo*. Illinois: Northwestern University.
- Smith, R. (2015, June 29). *Forbes*. Retrieved February 23, 2018, from Web of Forbes: <https://www.forbes.com/sites/ricksmith/2015/06/29/7-ways-3d-printing-is-already-disrupting-global-manufacturing/#7258fc361c0f>
- Strasys*. (2018). Retrieved March 23, 2018, from Web of Strasys: <https://www.strasysdirect.com/materials/selective-laser-sintering>
- Upadhyay, K., Dwivedi, R., & Kumar Singh, A. (2017). Determination and Comparison of the Anisotropic Strengths of Fused Deposition Modeling P400 ABS. In L. Jyothish Kumar, D. Ian Wimpenny, & P. M. Pandey, *Advances in 3D Printing*

& Additive Manufacturing Technologies (ISBN 978-981-10-0812-2 ed., p. 186).
Singapore: Springer Singapore.

APPENDICES

Appendix 1. Scanning Process of the boat of ACOLOR project

1 (9)

Before starting the scan, a strategy was thought because the boat is a large object that will cost to be computerize due to the large amount of data to be scanned. As the boat is symmetric, only one half of the boat was scanned and the symmetry was applied in the post-processing.

When the strategy was decided, all unnecessary objects were first removed from the surface to be scanned. After removing all the unnecessary objects, sweeping and cleaning of the dust and dirt of the surface is obligatory in order to stick the positioning targets easily.

When the boat was clean, the positioning targets were stuck following 2 rules explained below in order to make the scan work correctly.

1. In a surface of 30cm^2 there must be at least 3 positioning targets.
2. The positioning targets stuck must not generate a pattern. It is better to stick the positioning targets randomly without generating any pattern.

When VXelements program is started and the scanner is connected to the computer, the scanner must be calibrated and configured for scanning. For more information on how to carry out this process, consult the course "Pikamallinnuksen perusteet" in the "Scanner" section.

Once the calibration and the configuration are done, the resolution of the scan could be configured. Increasing the value of the resolution reduces the accuracy of the scan, but the generated file will be faster and lighter. However, if the precision is reduced, the file will be too heavy to have an easy post-processing.

2 (9)

In the case of the boat, a resolution of 2mm is used, providing lightness to the file without losing small geometries. Once the resolution is applied, the surfaces are scanned slowly, trying to avoid any area of the surface without scanning. When the scan is considered to be completed, the file is saved and backed up.

In the following figure, the result of the scan (the white dots are the positions where the markers were) can be seen. Only the interior of the boat was scanned but the floor was scanned partially. The exterior was not scanned because it is unnecessary for the assembly. Furthermore, if the exterior was scanned, a large file would be generated that could not be managed. In addition, the floor will be generated in CAD program making a lighter file. This is possible because the floor is plain and it has a single reference of the start, the end and the height.

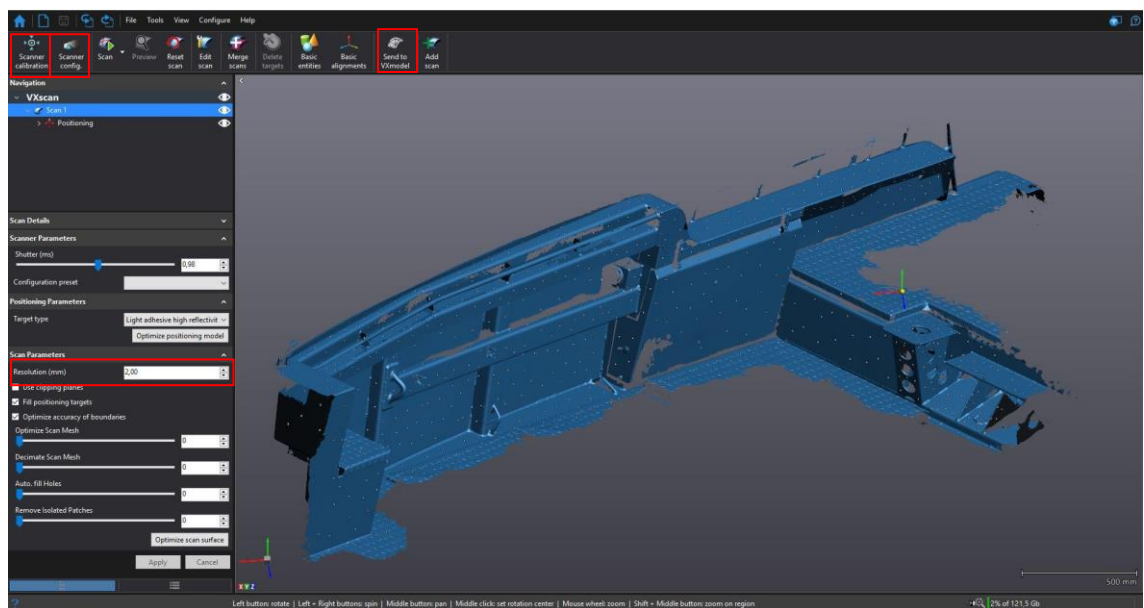

To perform the post-processing, the VXmodel file must be sent pressing the "Sent to VXmodel" button (the previous figure). Once the button is pressed, new options appear to be applied to the scanned model.

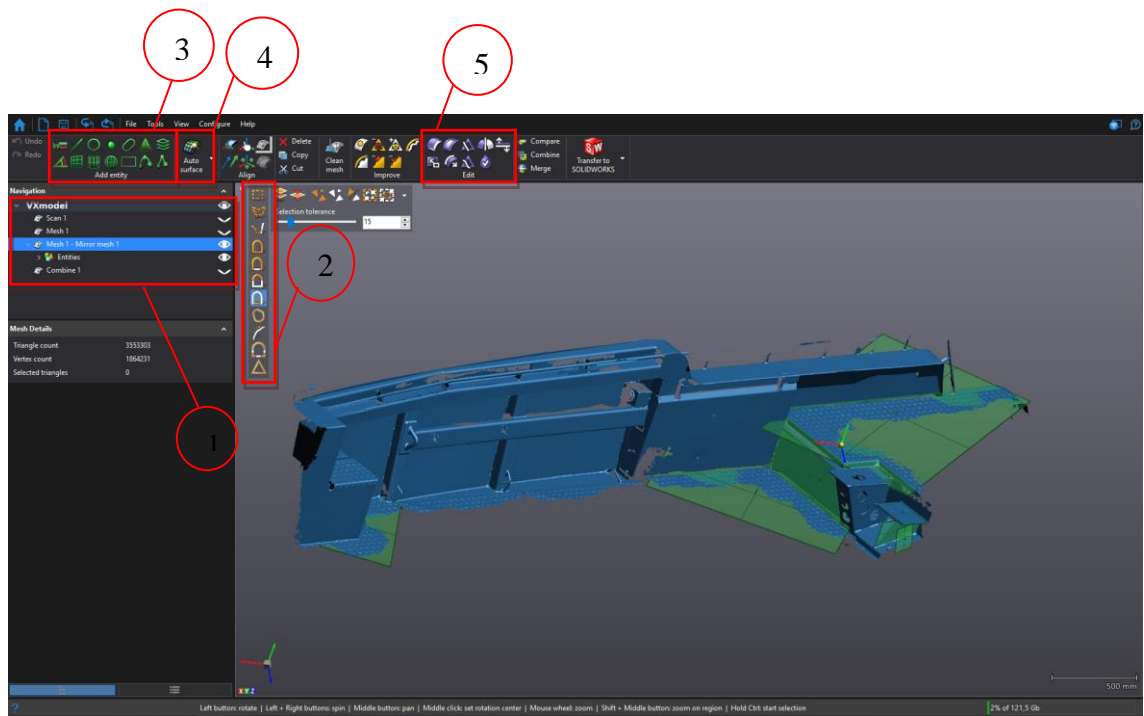

The tools indicated in the previous figure are those that will be used in the post-processing of VXmodel.

1. Navigation.
2. Selection of the mesh that you want to visualize and work, within each mesh there are entities which can be planes, surfaces or objects.
3. Selection.
4. Choose the selection method of the mesh. The most suitable options are the selection of the all the triangles in the same plane or the selection of the triangles in contact.
5. Add entity.
Tool that allows to add planes, surfaces and 3D geometries.
6. Automatic Surface.
Tool that generates a surface area of the selected mesh.
7. Edit.
Tool that allows to edit the mesh.

Due to the complexity and dimensions of the ship, the surfaces of the boat were generated in VXelements. The surfaces were not generated in SolidWorks because it takes a long times to be computerize. Moreover, SolidWorks does not have an optimal tool yet,

such as VXelements and its Automatic Surface tool. Although VXelements has the specialized tool to generate surfaces, program is collapsed when all the surfaces of the boat are trying to be generated. For this reason it was decided to separate the surfaces into 2 models.

First, the planes were created to generate a SW axis of coordinates, to facilitate the assembly in SW, to have a plane of symmetry and to be able to eliminate half of the excess scan.

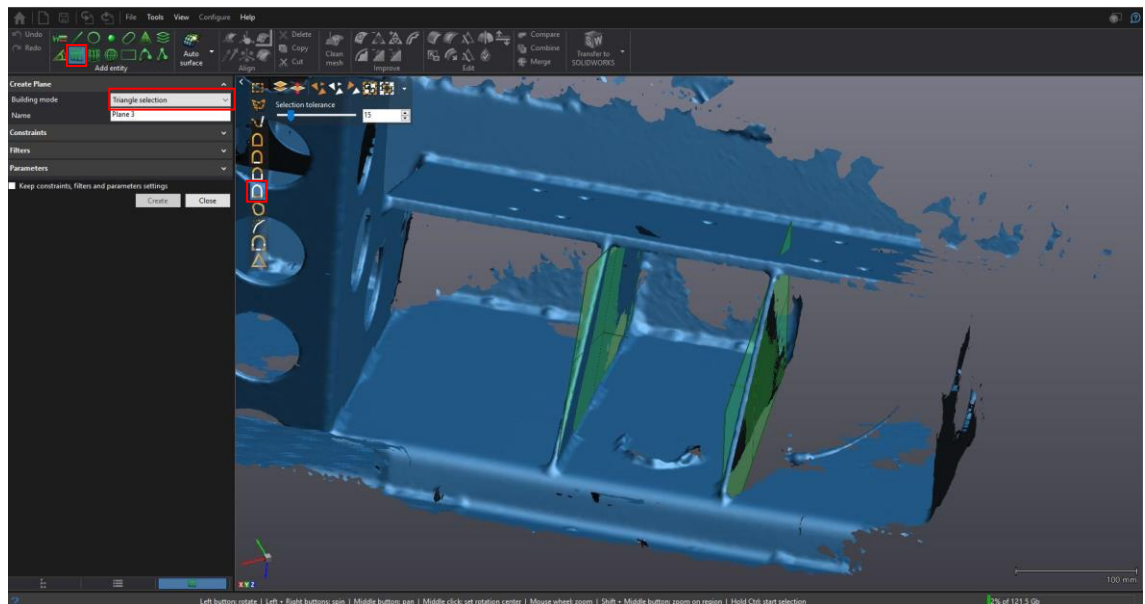

Two planes were generated using the building mode of the triangle selection, as shown in the previous figure, and using the two symmetrical surfaces which are closer to the plane of symmetry. The triangle selection generates a plane of the selected triangle (remember that a scanned model is generated from thousands of triangles).

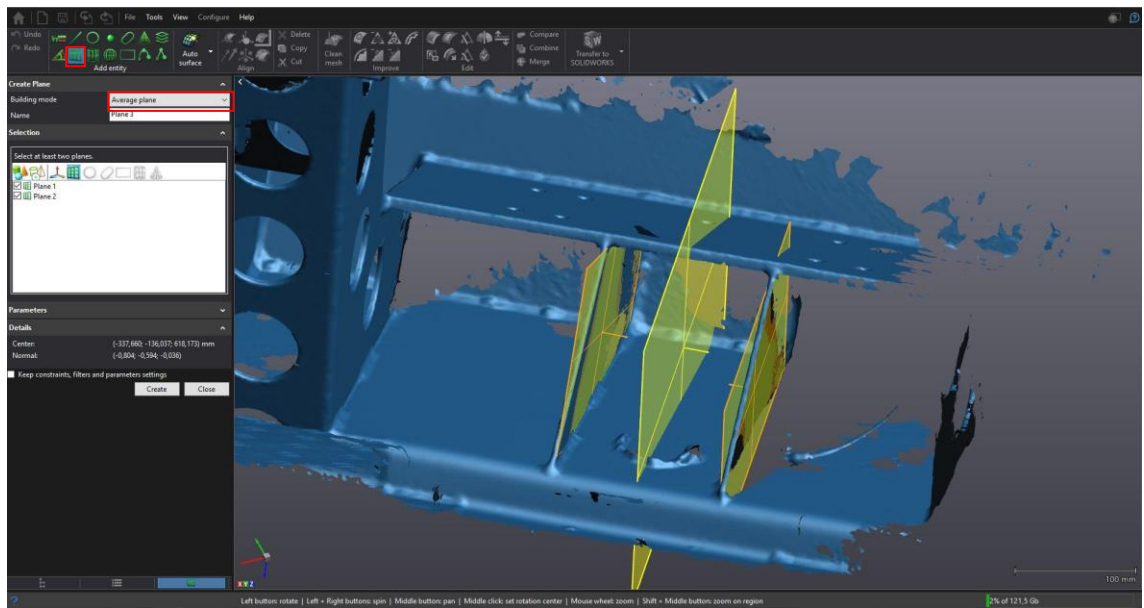

A plane was generated at the same distance between the two planes created before because they were parallel. In order to generate this plane, the building mode of the average plane is used. As shown in the previous figure.

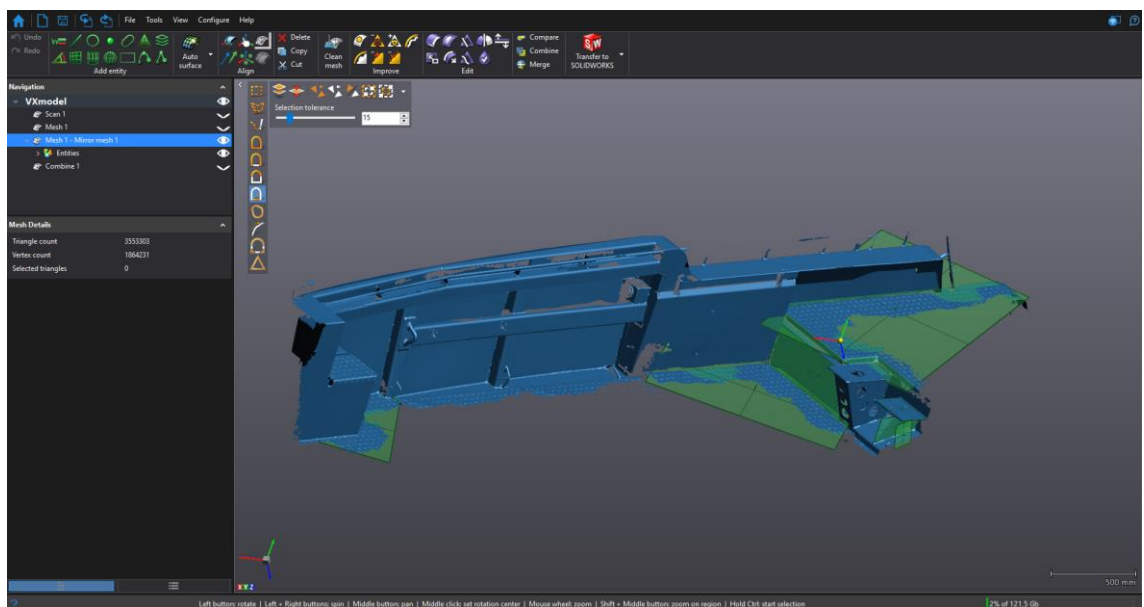

In the previous figure, all the planes created with the tools previously explained can be observed. These planes will be used for the generation of the floors in SW.

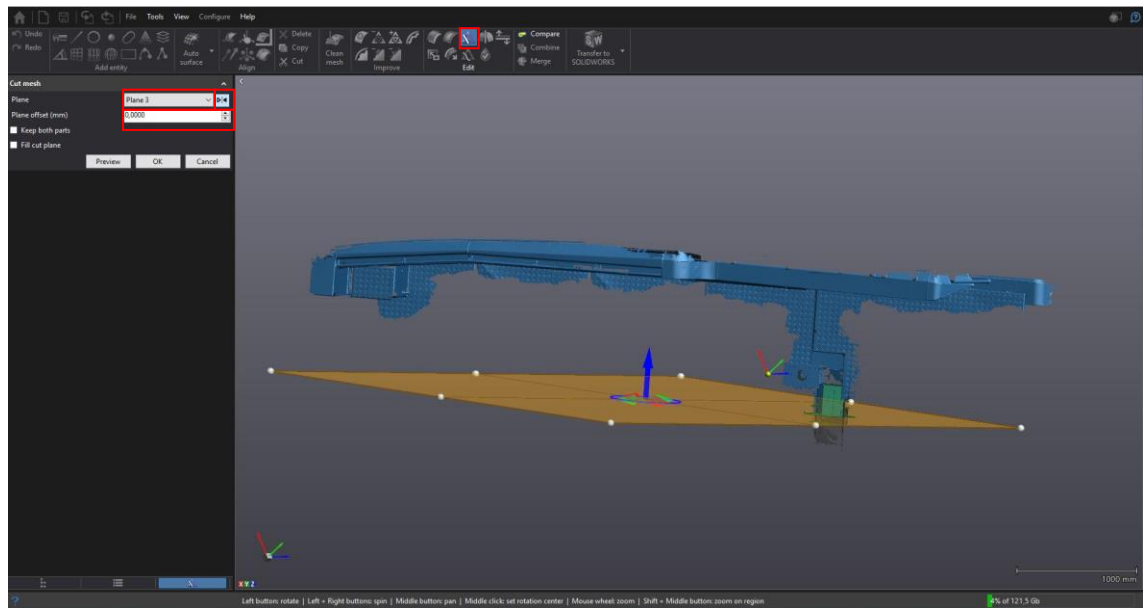

With the tool to edit the selected mesh, the unnecessary half was eliminated. With the option of “Plane”, the plane that divides the mesh in two sides was selected. With the button that follows the “Plane”, which divided mesh to be eliminated was selected. With the option of “Plane offset”, the distance to the plane of cut was selected. In this case, the plane of cut was the already chosen. For that reason, 0mm were left.

Before generating all the surfaces, 2 files were saved at this point. These 2 files will have different surfaces, but all the planes will be the same and will not give errors when they are assembled.

In one of the files, the surface shown in the following figure was generated. Since this large area is separated, the selection tool was used to select everything that is in relation to the selected triangle.

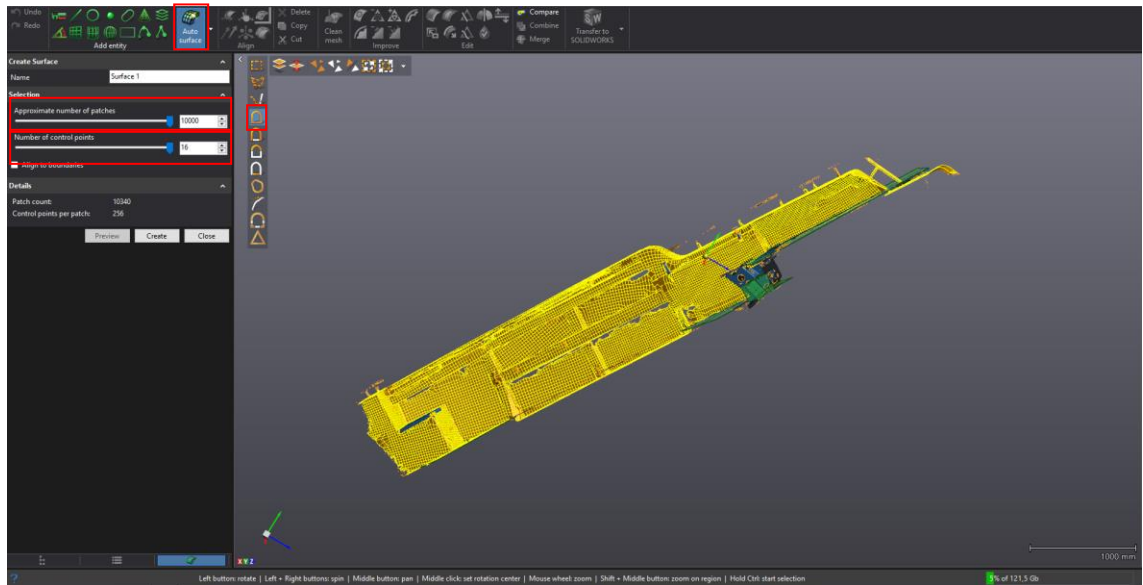

With the approximate number of patches, the selected the number of triangles will be generated in order to model the surface. With the number of control points, the selected the number of points will be in contact with the mesh. As the surface is very large to be generated, the maximum value in each option was selected.

When the creation of this surface is finished, the file is saved and all entities are transferred to SW. To transfer them correctly, select all the entities, click the right button on entities and click on transfer to SW. In SW, the other half was generated using the symmetry tool. The following figure is the final result of the first file.



Using the second file of VXelements, the other surfaces were generated. As the surface of the following figure is complex, the same parameters were used as in the previous one. Also, the same method of selection was used.

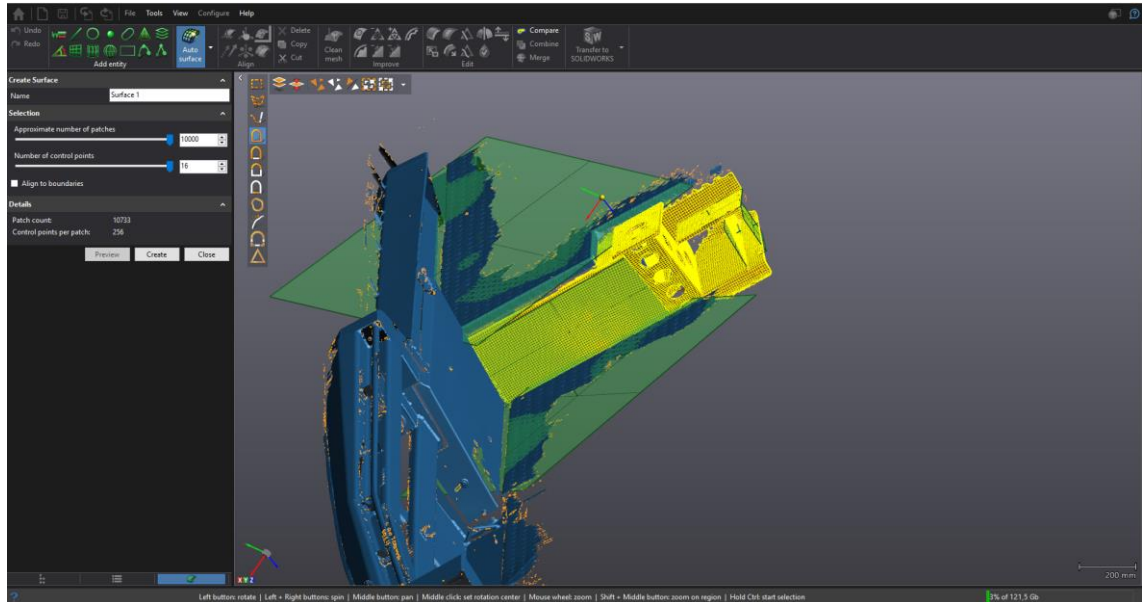

The following figure shows the surfaces generated marked. Also, the parameters were used in the generation of the surfaces. The preselected parameters in the program were not modified because the geometry was not complicated and the file became lighter.

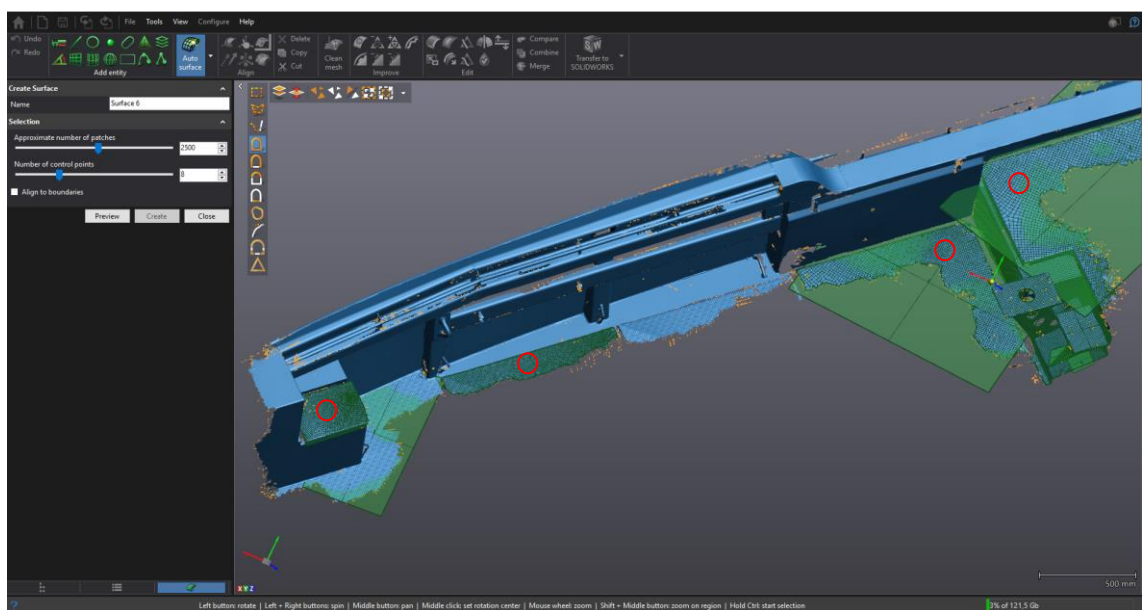

When the creation of this surface was finished, the file was saved and all entities were transferred to SW. In SW, using the symmetry tool we generated the other half and saved the file. In the following Figure it could be observed the result of this file.

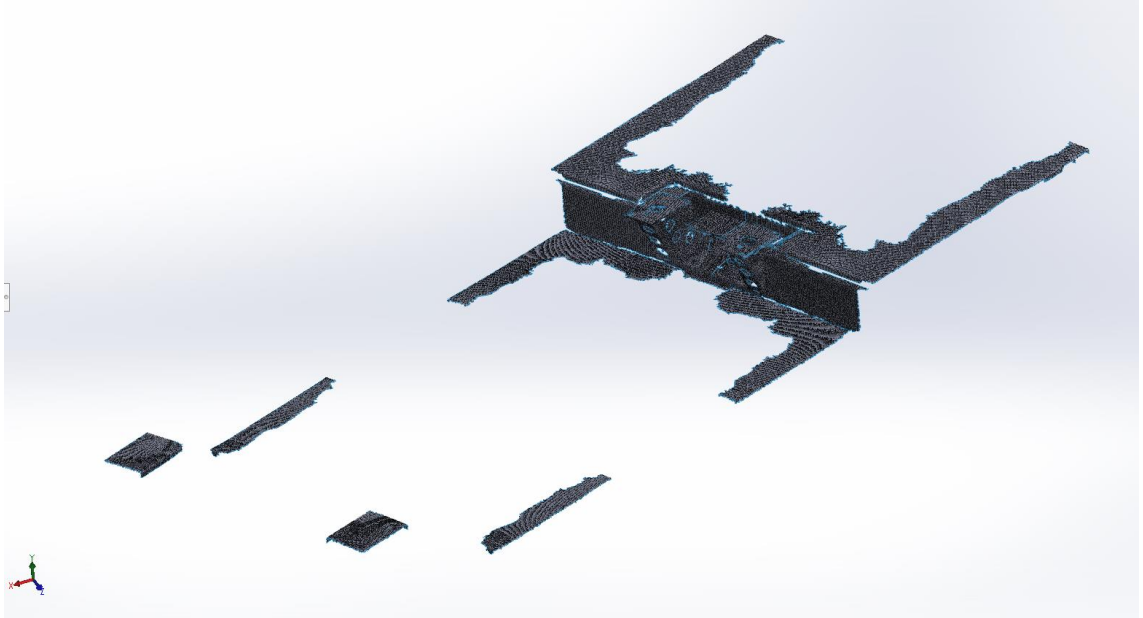

When the two files were obtained in SW format, an assembly was made. This assembly consisted of giving mates to the origins of coordinates of each file. These is because both files come from the same base file, all the entities that were generated before saving the two files coincide. The final result of the assembly can be observed in the following figure.

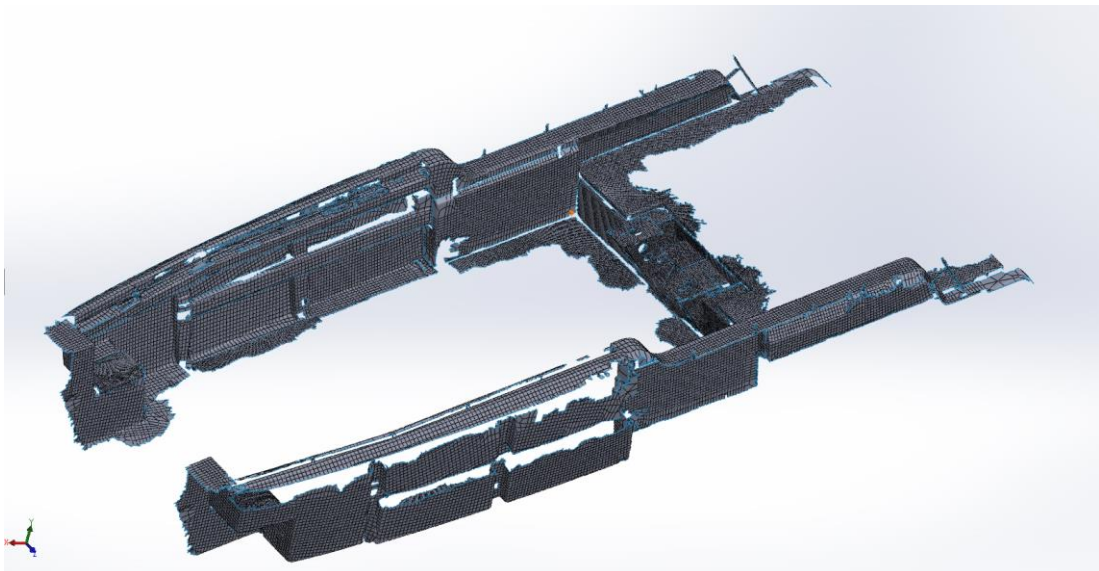

Appendix 2. Hardware needed for the scan

1 (3)

With the experience obtained from the post-processing scan of the boat of ACOLOR project, the computerization times were too long when trying to generate the surfaces in SW. More than 2 hours were expended to detect all the wanted surfaces to be generated. It was decided to search for information of the computer components that are currently available and to compare them with others in order to improve the performance of the computer. The graphics of this appendix are obtained from the “Linus Tech Tips” team (Gabriel Sebastian), this team makes comparisons and reviews of computer hardware. This comparison is made on February 2018 with the program “SPECView”, which shows the performance of the computer and SW.

The graphics card currently installed on the computer is a GTX 1080ti. This graphics card is from the range of video games. These cards are not designed for modelling jobs and their drivers are not optimized.

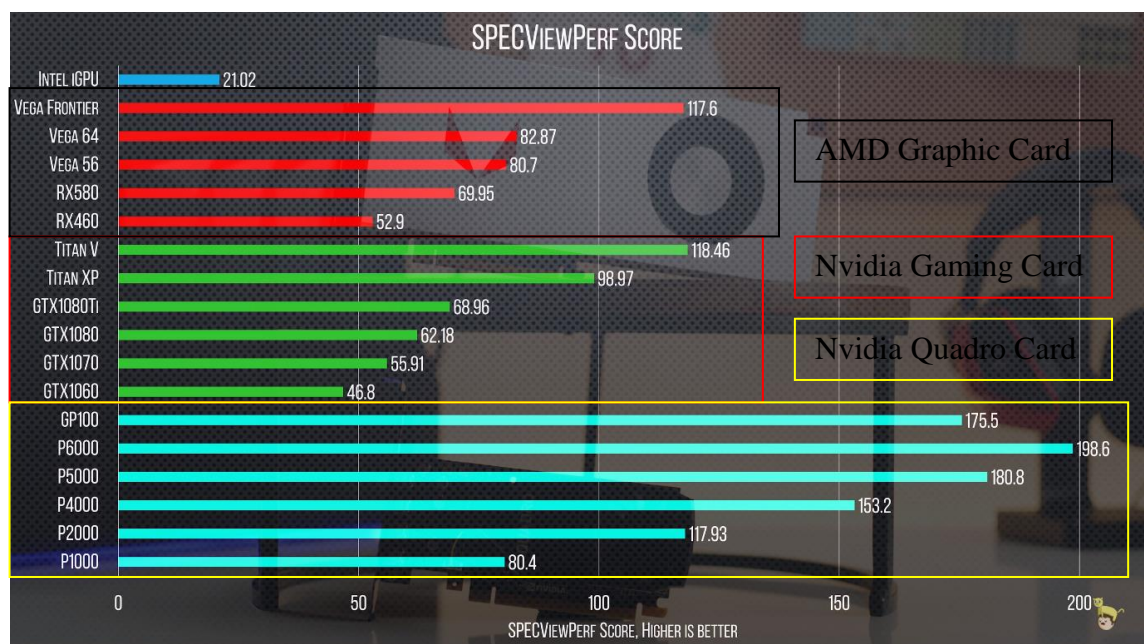

The previous graph is the values obtained due to the program. Higher value indicates a higher performance in SW. The Quadro range is designed for modelling and is the one that CAD program developers recommend because their programs are optimized for Quadro cards. With Quadro graphics cards, more polygons and pieces at the same time are possible to model.

The P4000 card and the GTX 1080ti have a similar price. The P4000 is much more suitable for the modelling and simulating (e.g. FEM) as seen in the graph. The GTX 1080ti has a faster clock speed that allows faster rendering. In addition, the GTX 1080ti has a higher consumption of electricity and is not designed for long jobs.

The processor which is currently installed is an Intel Xeon. This has more cores than the commonly used Intel I7. However, the cores of the Xeon are slower than those of the I7.

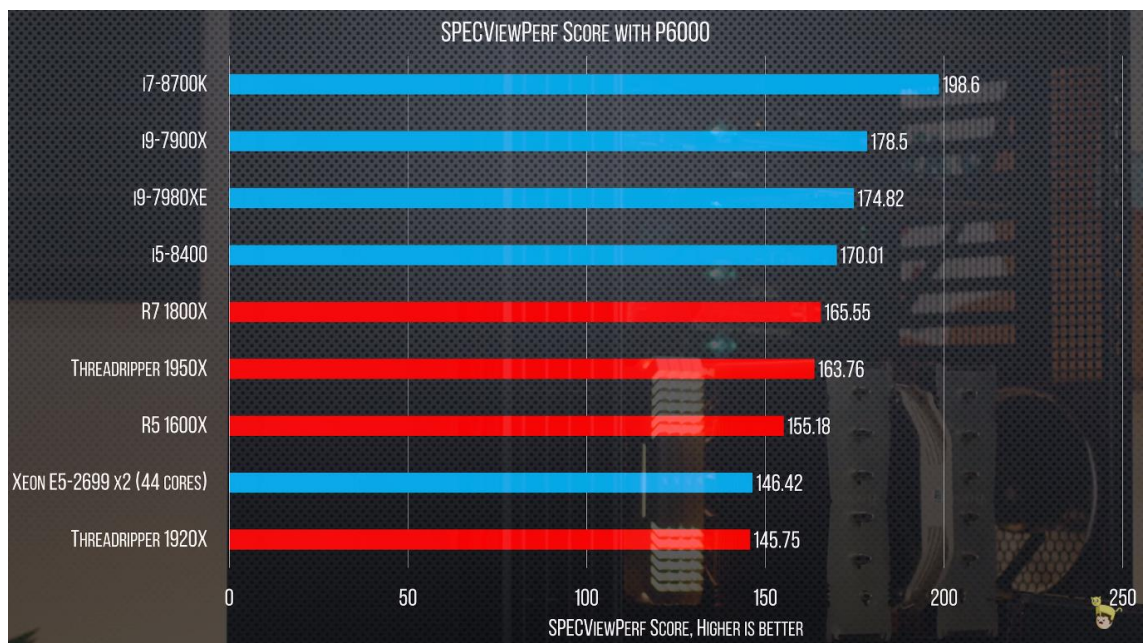

The previous graph is the comparison of the different processors working (the red bars are AMD brand processors while the blue ones are from Intel) with a P6000 (Nvidia Quadro) modelling in SW. For the modelling work, the single core performance is the most important. The Intel I7 is the most suitable for modelling because it is the one with the best single core performance.

The following graph is the comparison of the different processors working (the red bars are AMD brand processors while the blue ones are from Intel) with a P6000 (Nvidia Quadro) simulating and rendering. For simulation and rendering, the number of cores to solve the problem is the most important. The Intel Xeon is the best to render and simulate because it has more number of cores.

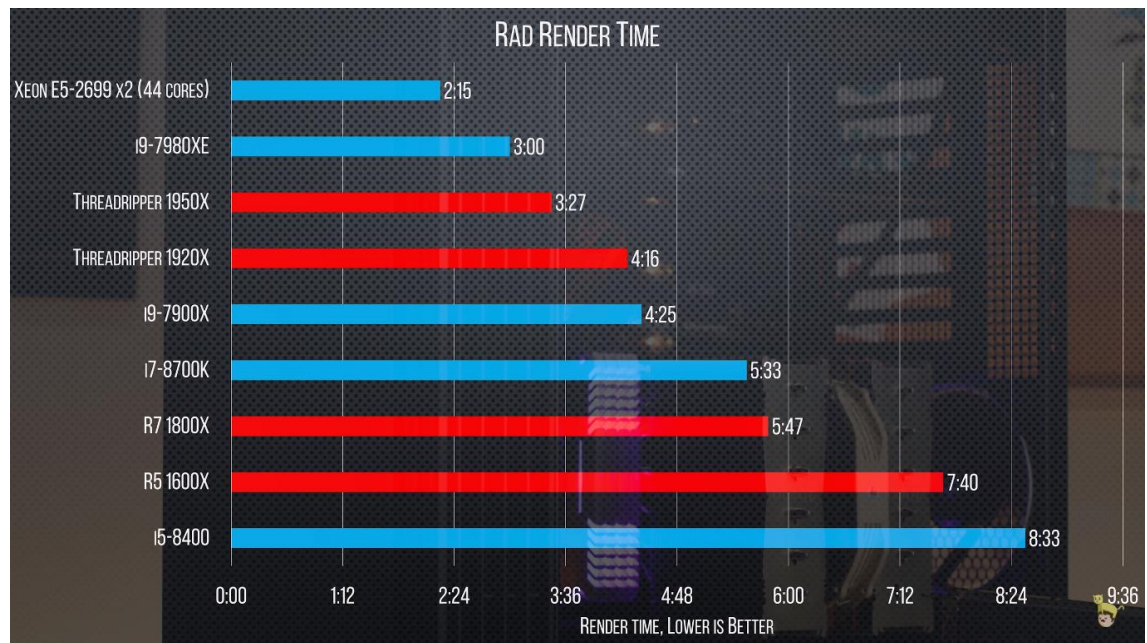

Taking all the previous results, it can be concluded that the pot-processing could have been done more quickly with a Quadro graphic card. This card would add SW complements that a GTX 1080ti cannot use. The boat with a surface generated by triangles would be easier to work with because the Quadro makes possible model more polygons.

If great rendering, simulate and model capabilities are wanted with the current computer, reducing the RAM from 128GB to 64GB would be more optimal in order to save money and invest it in a Quadro graphic card. With this optimization, the Quadro card would be used for all processes except rendering, which the GTX 1080ti would be used. Having 2 Quadro cards in the same computer is not optimal because SW can only use 1card.