



VAASAN AMMATTIKORKEAKOULU
UNIVERSITY OF APPLIED SCIENCES

Joonas Mäkinen

DIGITALIZATION OF THE PUMP TEST RIG

Technology and Communication
2019

VAASAN AMMATTIKORKEAKOULU
Energia- ja ympäristötekniikka

TIIVISTELMÄ

Tekijä	Joonas Mäkinen
Opinnäytetyön nimi	Pumpputestipenkin digitalisointi
Vuosi	2019
Kieli	englanti
Sivumäärä	29
Ohjaaja	Jukka Hautala

Tässä työssä tutustutaan Technobothnian energialaboratorion pumpputestipenkin toimintaan sekä annetaan tarvittavia tietoja testipenkin digitalisointia varten. Pumpputestipenkki on opetuskäytössä oleva järjestelmä, joka koostuu neljästä pumpusta. Testipenkin avulla voidaan tutustuttaa opiskelijat eri pumppujen toimintaan ja tehdä asiaan kuuluvia mittauksia. Pumpputestipenkin mittauslaitteisto on mekaaninen ja mittaukset täytyy tehdä laskemalla saaduista mittaustuloksista. Työn tarkoituksena on kerätä mittauksilla ja dokumentoinnilla tietoa, jota voidaan hyödyntää testipenkkiin hankittavien digitaalisten mittauslaitteiden hankinnassa.

Työssä tehtiin mittauksia pumppujen virtausalueen, nostokorkeuden ja vääntömomentin selvittämiseksi. Työssä selvitettiin, millä nopeusalueella moottori toimii. Mittauksilla annetaan tietoa ja valmiuksia mahdollisille tulevaisuuden laitehankinnoille. Työssä myös esitetään mahdollisia kehityskohteita ja ehdotuksia minkälaisia päivityksiä laitteeseen voidaan tehdä yleisellä tasolla.

Työ kokonaisuudessaan antaa kattavan tietopohjan digitaalisten mittalaitteiden hankinnoille. Opinnäytetyötä voidaan jatkaa siten, että kerätyillä tiedoilla voidaan kilpailuttaa yrityksiä, jotka tarjoavat digitaalisia mittalaitteita. Opetuskäyttöä tulevilla laitehankinnoilla voidaan monipuolistaa ja simuloida paremmin eri alojen prosesseja.

VAASAN AMMATTIKORKEAKOULU
UNIVERSITY OF APPLIED SCIENCES
Energia- ja Ympäristötekniikka

ABSTRACT

Author	Joonas Mäkinen
Title	Digitalization of the Pump Test Rig
Year	2019
Language	English
Pages	29
Name of Supervisor	Jukka Hautala

This thesis introduces the pump test rig operation used at the Technobothnia energy laboratory and provides the necessary information for the digitalization of the pump test rig. The pump test rig is in educational use, and which consists of four different pump types. The Pump test rig is used to familiarize students with the operation of various pumps and make measurement exercises. The pump test rig measuring equipment is mechanical, and the measurements must be made by calculating the obtained measurement results. The aim of the thesis is to gather information by measuring and documenting to be used to help acquiring digital measurement devices.

The measurements were made to determine the flow range, head and torque of the pumps. The speed range in which the motor is operating was also studied. The measurements provide information and capabilities for potential future equipment purchases. The thesis also presents possible development targets and suggestions for what kind of upgrades can be made to the device on a general level.

The thesis provides a comprehensive knowledge base for the acquisition of digital measuring devices. The thesis can be continued so that the data collected can be used to make tenders to companies that offer digital measurement devices. Educational use with future device purchases can be diversified and various industrial processes can be simulated.

Keywords Pump test bench, digitalization and measurement device

TABLE OF CONTENTS

TIIVISTELMÄ

ABSTRACT

1	INTRODUCTION AND THE OBJECTIVES OF THE THESIS.....	6
1.1	Educational Use	6
2	GENERAL INFORMATION FROM THE PUMPS	7
3	INTRODUCTION OF THE PUMP TEST RIG.....	9
3.1	Overview of the Test Rig.....	9
3.2	Motor.....	11
3.3	Introduction of the Pumps.....	12
3.3.1	Centrifugal Pump	12
3.3.2	Gear Pump.....	13
3.3.3	Axial Flow Pump	15
3.3.4	Turbine Pump.....	16
3.4	Measurement Capabilities.....	17
3.4.1	Measurement of the Flow.....	17
3.4.2	Measurement of the torque.....	19
3.5	P&ID Process.....	19
4	DEVELOPMENT AND MEASUREMENTS FOR DIGITALIZATION	21
4.1	Flow Meter Requirements Generally	21
4.2	Flow Rate and Head Range.....	21
4.3	Torque Range.....	22
4.4	Development proposals.....	24
4.4.1	P&ID sketch.....	24
4.4.2	Digital Meters.....	25
5	CONCLUSION	27
	REFERENCES.....	28

LIST OF FIGURES AND TABLES

Figure 1. Displacement pump QH-diagram. /6/	8
Figure 2. Dynamic pump QH-diagram. /6/	8
Figure 3. Pump test rig	9
Figure 4. Control Panel	10
Figure 5. Gauge panel	11
Figure 6. The motor	12
Figure 7. Centrifugal pump /1/	13
Figure 8. Gear pump diagram /1/	14
Figure 9. Axial flow pump diagram /1/	15
Figure 10. Turbine pump diagram /1/	16
Figure 11. Volumetric tank scale	17
Figure 12. Hook and point gauge	18
Figure 13. Torque measuring beam	19
Figure 14. P&ID process at current state	20
Figure 15. P&ID process of suggested updates	24
Figure 16. Top panel	26
Table 1 P&ID process item list	20
Table 2. Range of flow and pressure for each pump	22
Table 3. Pump/motor teeth ratios	23
Table 4. Torque range for each pump	23
Table 5. Updated item list	25

1 INTRODUCTION AND THE OBJECTIVES OF THE THESIS

The subject of this thesis work is the digitalization of pump test rig. The test rig is in the Technobothnia energy laboratory, and it demonstrates the principles of four different pump types. The aim is to modernize the pump test rig by giving information and requirements for the acquisition of digital measurement systems for the old flow measurement systems. At the beginning of the project the intention was to update laboratory exercise instructions, but due to time constraints this was not possible.

Modernizing measuring equipment in the laboratory environment shows the difference in measuring accuracy and convenience of the digital measurement devices. New digital measurement devices will develop studying and enhance the understanding of how each measurement method works in practice.

1.1 Educational Use

The task of the laboratory exercise is to familiarize the student with the operating principles of the pumps. The laboratory exercise will introduce the working principles of centrifugal pump, gear pump, axial flow pump and turbine pump. The results of the exercise are important in many fields of technology, because almost all industrial processes contain different pumps.

The pump test rig introduces students to concepts such as flow, lifting height, hydraulic power, mechanical power and efficiency. The students job is to resolve previously mentioned concepts and use answers to create pump curves and efficiency curves for each pump. One part of the exercise is to compare each pump, which pump suitable for producing high pressure and low flow and which pump is suitable for producing high flow and low pressure. Finally, the students must answer questions, such as which pump has the best efficiency, how pump curves behave as a function of rotational speed in each pump and should the control valve be open or closed when starting the pumps? Comprehensive exercises help students to understand different concepts and principles of machines efficiently. Introducing concepts like this is very useful for engineer students to learn, because it is likely they face them in working life

2 GENERAL INFORMATION FROM THE PUMPS

The conversion of mechanical energy into fluid energy by machines is one of the major concerns to most engineers and for the people who work in technical field. The types of hydraulic machines available for this conversion vary considerably in principle and design. The selection of the correct pump for application is essential for efficient, satisfactory operation /1/.

In industries pumps are used for a wide range of applications across many industries. Typically, industrial pumps can move large amounts of different types of products including water, chemical, petroleum, oil, sludge or slurries. Usually industries use centrifugal pumps and positive displacement pumps.

A pump is simply a machine used to move liquid through a piping system, and to raise the pressure of the liquid. A pump can be further defined as a machine which uses several energy transformations in order to increase the pressure of a liquid. The energy input into the pump is typically the fuel source energy used to power the driver. Most commonly electricity is used to power an electric motor. /4/.

Pumps can be divided to two groups displacement pumps and to dynamic pumps. The running method of displacement pumps is simple, the displacement part of the pump displaces the amount of liquid corresponding to the displacement volume from the housing to the pressure outlet pipe. Displacement pumps operate intermittently when the suction and displacement phase alternate or evenly, when the pump absorbs and displaces fluid simultaneously /4/.

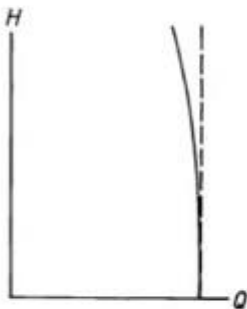

Figure 1. Displacement pump QH-diagram. /6/

In dynamic pumps, the mechanical energy or kinetic energy of the pump is converted into motion and pressure energy. For dynamic pumps, it is characteristic that while the flow increases the lift height decreases significantly as can be seen in **Figure 6**. With displacement pumps, the rate of flow remains almost the same regardless of the lift height /4/.

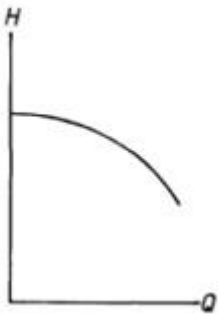

Figure 2. Dynamic pump QH-diagram. /6/

3 INTRODUCTION OF THE PUMP TEST RIG

The pump test rig is in educational use for engineering students in the Technobothnia laboratory facility. Using the test rig is a great way to understand the techniques the different types of pumps use to transfer liquid. The test rig includes four different pump types, which use very different technology compared to each other. Using this kind of rig in educational use displays different liquid transferring principles in one system. Measuring flow, pressure and torque shows the different advantages and disadvantages each pump type has.

3.1 Overview of the Test Rig



Figure 3. Pump test rig

The pump test rig equipment is mounted on a metal framework provided with a plastic laminate covered working surface. A door is connected to the electric safety interlock to provide a safe access to the dynamometer motor and to the pump for belt changing

when the operating pump need to be changed. Hand operated valves are easy to access, one on the top surface of the framework, and another on the left-hand side of the frame and four valves are on the front panel.



Figure 4. Control Panel

Release from the centrifugal, gear or turbine pumps is fed to a common manifold which includes a flow control valve. The pump to be calculated is chosen by opening the right selector-valve on the panel. The axial flow pump has an independent, combined selection and regulator valve mounted over the channel. Each pump circuit is provided with its own discharge pressure gauge and the four gauges are mounted on the instrument panel /1/.

The suction from each pump is measured by a common vacuum meter centrally mounted in the instrument panel. A manifold with four raises provides the relevant connection between pump and vacuum gauge /1/.



Figure 5. Gauge panel

3.2 Motor

The motor that runs the pumps is a 500W DC motor, it has two shafts fitted with taper lock scrubs and timing belt cranks. An electronic tachometer is mounted in the instrument panel, which indicates the motor, speed detected by a non-contacting sensor on one shaft of the motor. When running the motor there is a possibility to measure the torque of the motor at different speeds /1/. **Figure 4** shows the two-sided shaft, which allows the belt change for both sides of the motor and the linking rod to torque measuring beam.



Figure 6. The motor

3.3 Introduction of the Pumps

3.3.1 Centrifugal Pump

A centrifugal pump consists of an impeller attached to and rotating with the shaft, and a casing which encloses the impeller. In a centrifugal pump, liquid is forced into the inlet side of the pump casing by atmospheric pressure or some upstream pressure. As the impeller rotates, liquid moves toward the discharge side of the pump. The pressure at the pump casing inlet, which is higher and this reduces pressure at the impeller inlet, forces additional liquid into the impeller to fill the empty space /4/. The pump has a suction connected to the sump tank via a suction regulator valve. Its delivery is connected to the selection manifold and measuring system via globe valve /1/.

Centrifugal pumps can transfer large volumes without any dependence on valves or fine clearance and can be run against closed valve without developing a high pressure. They can handle wide range of slurries, or solids in suspension, in addition to liquids with high viscosities /4/.

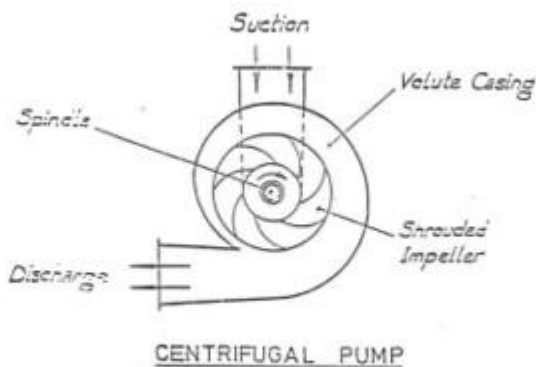

Figure 7. Centrifugal pump /1/

The main disadvantage of centrifugal pump are that there is a limitation of delivery pressure and their inability to prime themselves. This can be overcome by using twin, or multi-stages usually on the same spindle axis. The fitting of a self-primer will eliminate the latter disadvantage /1/. Centrifugal pumps are a widely used pump type and can be used in various areas such as: industrial, power generation, agricultural, chemical and pharmaceutical use.

3.3.2 Gear Pump

The positive displacement gear pump has a casing and two gear-shaped impellers, rotating with close clearance, catching such that water entering the suction port is trapped in the spaces between adjacent teeth and carried round to be squeezed out and discharged through the outlet port /1/.

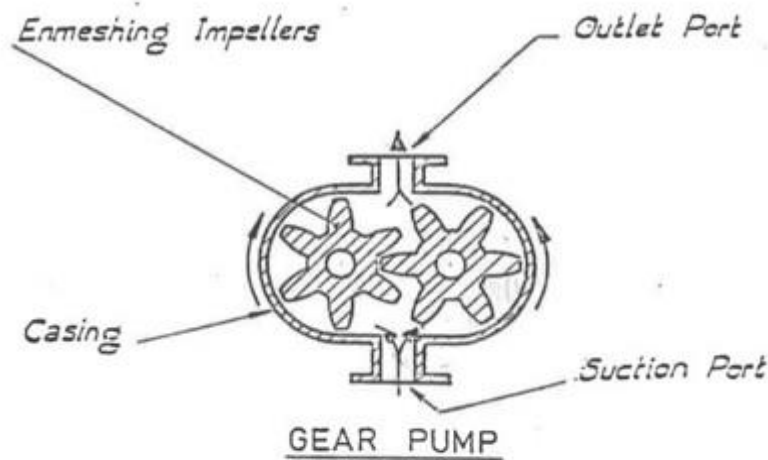

Figure 8. Gear pump diagram /1/

High pressures can be achieved with gear pumps and a pressure release valve is incorporated to the 75mm head, to protect the pump and system. The suction port is connected directly to the pump tank and its delivery port is connected to the selection manifold and measuring system via globe valve /1/.

Advantages of external gear pumps include the fact that they operate at relatively high speeds, producing relatively high pressures. The gears are usually supported by bearings on both sides, so there are no overhung loads /4/. A significant advantage of this type of pump is that no valves are required in the suction or distribution. It is capable of pumping air, gas or liquid without any detrimental effect and does not require priming /1/.

The major disadvantage of the gear pump is that very close clearances are required between the ends of the rotors and the casing. Corrosion and wear in this section of the pump will be detrimental for the pump overall efficiency /1/.

Gear pumps are often used as lubrication pumps in machine tools, in fluid power transfer units and as soil pumps in engines. A tighter internal clearance provides more reliable measure of liquid passing through a pump and for greater flow control. Gear pumps can be used in various applications such as, fuel oils and lube oils, chemical additives, chemical mixing and blending, industrial and mobile hydraulic applications and acids

/3/.

3.3.3 Axial Flow Pump

The axial flow pump has a 50mm pitch propeller running in a casing with fine clearances between propeller and casing. Water enters the propeller axially through a ring of fixed inlet guide vanes. In passing through the propeller, the blades impart a whirl component into the fluid which the outlet guide vanes remove before to the fluid entering the discharge pipe. The propeller is mounted on an extended shaft running on a plain bearing /1/.

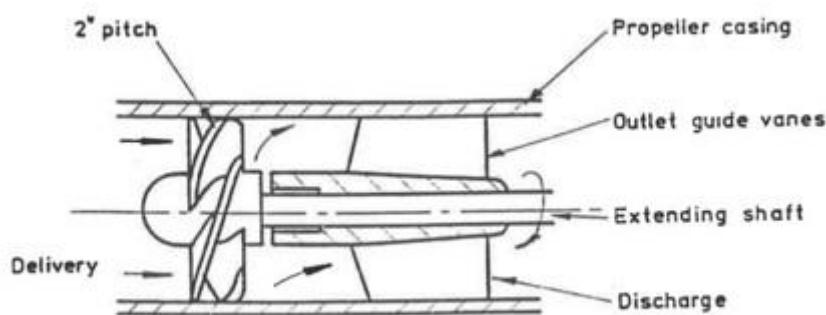

Figure 9. Axial flow pump diagram /1/

The volumetric tank is utilized to provide an increased suction head to the axial flow pump and a plug is provided to seal in the base of the tank when the axial flow pump is not in use. Delivery is controlled via a gate valve mounted on the working surface top and feeding the channel directly /1/.

The axial flow pump is most appropriate in conditions where a large discharge flow is to be delivered against a low head. Land drainage, irrigation and sewage pumping are some typical applications. The pump efficiency is comparable with the centrifugal type. However, its higher relative speed permits smaller and cheaper pumping and driving units to be provided.

Axial flow type pumps are often used in applications which require low pressures and high flow output. For example, axial flow pumps are used to transfer liquids in evaporators, sewage digesters and in power plants /5/.

3.3.4 Turbine Pump

The turbine pump also known as a regenerative or peripheral pump, has a straight bladed impeller in an annular casing, and a drive shaft supported on two grease-packed ball races. The front cover and seal housing are cast, and the impeller is machined from a blank /1/.

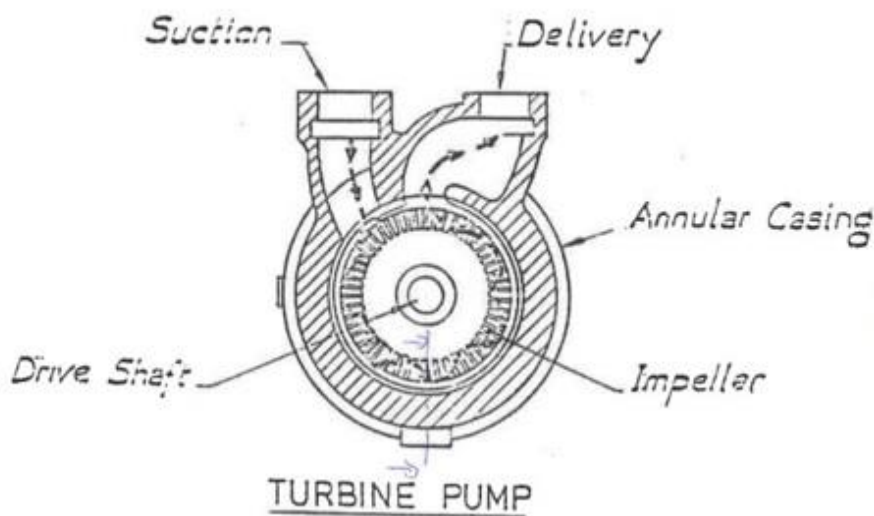

Figure 10. Turbine pump diagram /1/

The seal, which is of the rotary mechanical type, is self-lubricating. This pump is not self-priming and operated from flooded suction. The suction is connected directly to the sump tank and its delivery is connected to the selection manifold and measuring system via a globe valve /1/.

While on centrifugal pump the liquid travels through impeller once, on turbine pump the liquid takes many trips through the vanes. Once the liquid enters the pump, it is directed into the vanes, which push the liquid forward and impart a centrifugal force outward to the impeller sideline. An orderly circulatory flow is therefore imposed by the impeller vane, which creates fluid velocity. Kinetic energy is then ready for conversion to flow and pressure /7/

Turbine pumps are used in applications where high pressure and low flow rate are

needed. Turbine pump applications are usually where clean liquid is transferred. They are used applications such as, cooling water circulators, small boilers and other commercial plants /8/.

3.4 Measurement Capabilities

3.4.1 Measurement of the Flow

Flow can be measured with two methods volumetric tank method, shown in **Figure 11** and hook and point gauge method shown in **Figure 12**. The volumetric tank method is usually used when testing the gear pump, centrifugal pump and turbine pump. It is necessary to use the hook and point gauge method when testing the axial flow pump, as the volumetric tank is then in use to provide a head of water for the pump /1/.



Figure 11. Volumetric tank scale



Figure 12. Hook and point gauge

The measuring tank is stepped to accommodate high or low flow rates and includes a remote sight tube and progressed scale. It is calibrated in liters of water stored. A safety overflow is incorporated spilling water directly back into the sump tank in the event of incorrect use. The sump tank is fitted with a drain valve which is used as the suction connection for the ram pump accessory if it is installed /1/.

On the volumetric tank method, the motor speed is set at a certain point and a stopwatch is set at zero and the plug is placed and the stopwatch started when the water level reaches the zero mark, once water level reaches desired volume, the stopwatch is stopped. The lower scale from 0 to 6 litres can be used or the larger scale 0 to 40 litres for higher flow rates as shown in **Figure 11**.

On the hook and point gauge method the Vernier measuring instrument is used which is mounted over the water channel. It is used to measure the change of level of the water as it flows through the channel and over the weir leading to the volumetric tank. The difference in water levels is related to the rate of flow of the water. This method of flow measurement must be implemented when testing an axial flow pump /1/.

3.4.2 Measurement of the torque

The torque balance is connected to the motor by a firm link and includes a measuring beam, graduated with dual scale calibrated directly in Newton meters. The rotating beam is balanced to zero by an adjustable screwed counterweight. Two sets of weights are provided to measure low and high range against their appropriate scales /1/.



Figure 13. Torque measuring beam

3.5 P&ID Process

Figure 14 displays the P&ID process layout of the pump test rig at the current state, which shows how the liquids are flowing through the pipelines from the sump tank to the measuring tank. Pressure indicators measure the lifting height of the different pumps and the lifting height is readable from the gauge panel on top of the rig. The bottom tank is the sump tank and two tanks that is located above the sump tank are measuring tanks.

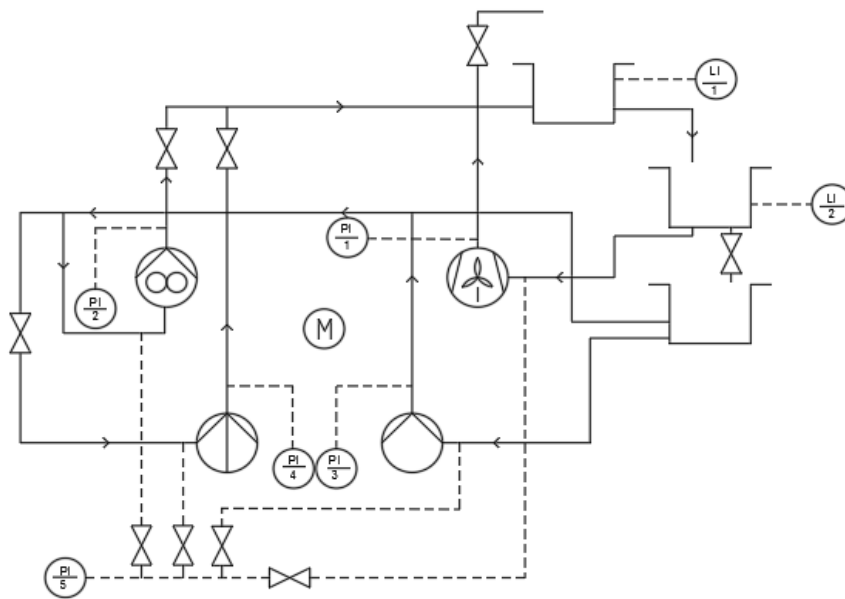

Figure 14. P&ID process at current state







Item list	Description
	Centrifugal pump
	General Pump (Turbine pump in this case)
	Axial flow pump
	Gear pump
	Valve, general
	Water level indicator
	Pressure indicator

Table 1 P&ID process item list

4 DEVELOPMENT AND MEASUREMENTS FOR DIGITALIZATION

Adding digital measurement devices to the pump test rig alongside to the already existing mechanical measuring methods brings convenience and accuracy to measurements. Having digital measurement capabilities as an alternate method enables the simulation of an industrial environment with both mechanical and digital measurements implemented to the system.

4.1 Flow Meter Requirements Generally

When selecting a flow meter, it is significant to find out which types are most suited to application. For example, electromagnetic meters provide for the widest flow range, turbine meters are usually a safe choice for the highest short-term repeatability and orifice plate meters are the most commonly used metering device /12/. For pumping liquid there is very little restrictions when choosing the flow meter because practically every flow meter type can measure liquids /9/.

Knowing the flow and head range are both important factors to consider when choosing the flow meter /9/. The expected minimum and maximum pressure and temperature values are also important to know when selecting flowmeters. The accuracy of a measurement depends on more than one factor. A low cost, low quality flow meter is likely to provide lower accuracy measurements and the same is true in reverse.

4.2 Flow Rate and Head Range

The measuring range of flow rate and head is necessary when choosing flow meter to the system, for example. There are different types of flowmeters for every occasion, so this knowledge is necessary when deciding the type of flow meter.

The measurements were done so that the motor speed was kept the same in each measurement and the head and flow rate values was taken so that the control valve was completely open and when the control valve was closed. The results indicate that the pumps have characteristics as **Figure 6** and **Figure 7** show.

Table 2. Range of flow and pressure for each pump

Gear pump	Open control valve	Closed control valve
Pump speed	970	970
H (m)	0,75	44,5
Q (l/s)	0,29	0,015

Centrifugal pump	Open control valve	Closed control valve
Pump speed (rpm)	1830	1830
H (m)	2,2	5
Q (l/s)	0,74	0,15

Turbine pump	Open control valve	Closed control valve
Pump speed (rpm)	2800	2800
H (m)	-	9,4
Q (l/s)	0,34	0,11

Axial flow pump	Open control valve	Closed control valve
Pump speed (rpm)	2800	2800
H (m)	0,65	1,5
Q (l/s)	1,4	0,1

4.3 Torque Range

The torque is what helps to spin the shaft to provide power to the motor. Without properly measuring the torque, machines may hesitate when loads constantly change and they cannot handle the differences in weight. The measuring range of torque on all four pumps sets the requirements when acquiring new torque measurement devices.

The measurements were done with a torque measuring beam on the pump test rig. The first measurements were done with the control valve open and the other measurement with a tightened down control valve. The motor speed was kept at the maximum 1450 rpm for each pump measurement. The results in **Table 4** shows that torque does not vary much between the pumps except that the turbine pump torque increases slightly.

The speed range of the motor is up to 1450 revolutions per minute, you can control the

speed of the electric motor with the adjustment knob. Below the knob is the motor speed gauge which shows the speed up to 2000 rpm. In order to calculate the actual pump speed, you must refer pump/motor speed ratios shown in the **Table 3**.

Table 3. Pump/motor teeth ratios

Pump type	Pump/Motor teeth ratio
Centrifugal pump	23:17
Axial flow pump	27:14
Gear pump	23:32
Turbine pump	27:14

Table 4. Torque range for each pump

Centrifugal pump	Open control valve	Tightened control valve
Motor speed (rpm)	1450	1450
Pump speed (rpm)	1960	1960
Torque (Nm)	0,87	0,59

Gear pump	Open control valve	Tightened control valve
Motor speed (rpm)	1450	1450
Pump speed (rpm)	1040	1040
Torque (Nm)	0,38	0,74

Turbine pump	Open control valve	Tightened control valve
Motor speed (rpm)	1450	1450
Pump speed (rpm)	2800	2800
Torque (Nm)	1,7	2,1

Axial flow pump	Open control valve	Tightened control valve
Motor speed (rpm)	1450	1450
Pump speed (rpm)	2500	2500
Torque (Nm)	0,32	0,4

4.4 Development proposals

This subchapter introduces possible specific locations for digital measurement indicators and gauges. Locating digital measuring indicators to efficient locations in order to minimize expenses is important to notice while designing the digital equipment. A digital indicator is good to have a distance to other instruments in the pipeline to avoid possible disturbances. This subchapter proposes locations for digital meters to be installed in an efficient way.

4.4.1 P&ID sketch

The sketch in **Figure 15** presents possible updates to the pump test rig. The test rig previously had mechanical flow measuring methods, so the P&ID process layout sketch shows a possible location for two flow indicators. One flow indicator is located on the pipeline of the axial flow pump and the other indicator is measuring on the pipeline common to the turbine, centrifugal and gear pumps.

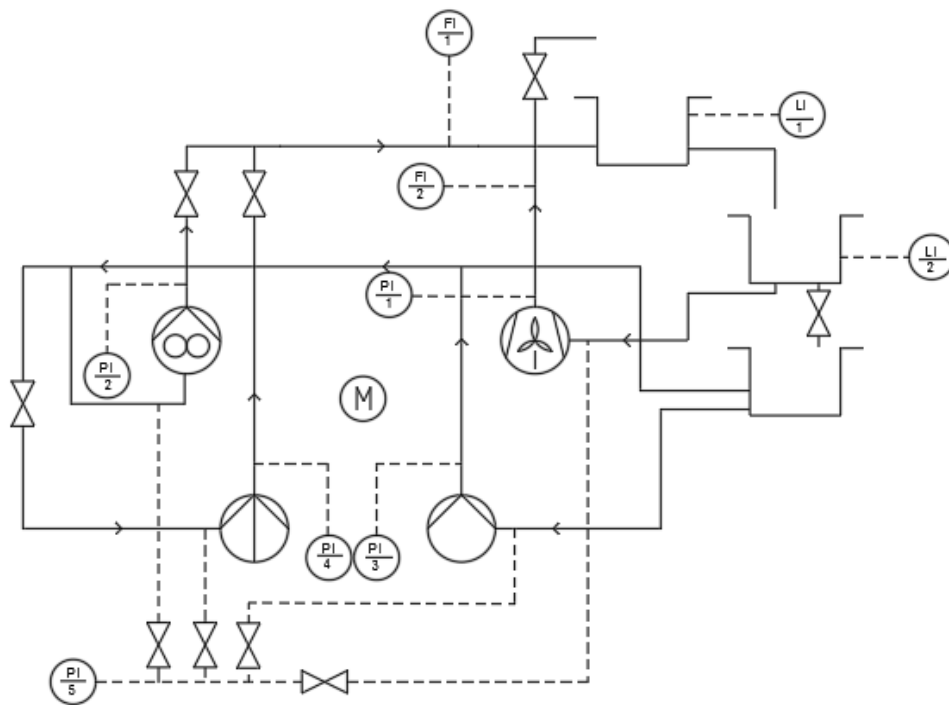









Figure 15. P&ID process of suggested updates

Table 5. Updated item list

Item list	Description
	Centrifugal pump
	General Pump (Turbine pump in this case)
	Axial flow pump
	Gear pump
	Valve, general
	Water level indicator
	Pressure indicator
	Flow indicator

4.4.2 Digital Meters

Mechanical meters are good to have even if digital meters are installed, that way reliable results can be obtained and compared easily. Physically meters need space so that they are not in the way of any processes and they are easy to access. Digital meters could be installed on the right side of the mechanical meter panel (see **Figure 16**), so that they are mounted to the old mechanical meter panel. There would be practically most useful place for the meters, and they would not disturb any processes.



Figure 16. Top panel

5 CONCLUSION

In this thesis, the measurement equipment and the operation of the various devices of the test rig have been reviewed and information gathered by measuring and studying the various subjects this thesis includes. With this information and research, it is easier to start acquiring and decide which kind of digital measurement device is best suited for this pump test rig. The thesis can be further continued by researching specific measurement device manufacturers and start to make tenders for companies.

From the educational point of view digitizing the pump test rig is an efficient way of introducing students to digital measurement devices that are used in various industries. Modernizing the measurement systems gives a comparison of the mechanical measurements, which is useful for learning purposes. While it is important for learning to use practical methods to prepare the measurements, the digital measurements present newer technology what is used in industrial areas where engineers work.

REFERENCES

- /1/ Instruction Manual, multipurpose test rig with ram pump accessory unit. 1995. Accessed 6.3.2018.
- /2/ Motiva. Energiatehokkaat pumput. Accessed 13.05.2019
http://www.motiva.fi/files/5343/Energiatehokkaat_pumput.pdf
- /3/ Jenner, C. Gear Pumps. Accessed 16.05.2019
<http://processprinciples.com/2012/07/gear-pumps/>
- /4/ Volk, M.W. 1996. Pump Characteristics and Applications. Accessed 12.04.2019
- /5/ Axial flow pumps information. Accessed.13.05.2019
https://www.globalspec.com/learnmore/flow_transfer_control/pumps/axial_flow_pumps
- /6/ Kurunlahti, P. Vedenpumppauksen energiatehokkuus. Accessed 3.05.2019
https://www.theseus.fi/bitstream/handle/10024/59514/kurunlahti_pekka.pdf?sequence=1&isAllowed=y
- /7/ MTHPumps. Regenerative pump principles. Accessed 14.05.2019
<http://www.mthpumps.com/turbine.html>
- /8/ Turbine Pumps Information. Accessed 14.05.2019
https://www.globalspec.com/learnmore/flow_transfer_control/pumps/turbine_pumps
- /9/ Davis, M. Considerations for choosing a flow meter. Accessed 17.05.2019
<https://www.pumpsandsystems.com/topics/instrumentationcontrols/considerations-choosing-flow-meter>
- /10/ Säättö. Virtausmittarit nesteille. Accessed 15.05.2019
<https://saato.fi/tuote-kategoria/virtausanturit-nesteille/>
- /11/ Keuda. Prosessin ohjaus. Accessed 15.05.2019
<https://keuda.moodle.fi/mod/page/view.php?id=351408&inpopup=1>
- /12/ ABB. Tips for flow meter selection. Accessed 15.05.2019
<http://www.abb.com/cawp/seitp202/12439c2f1ac1a1a180256c800037b15d.aspx>
- /13/ River glennapts. Virtausmittarit. Accessed 18.05.2019
<https://riverglennapts.com/fi/meters/584-flow-meters-types-of-flow-meters.html>

