

Auxiliary engine DO leak tank installation onboard M/V Figaro

Jonas Olin

Degree Thesis for Maritime engineering (YH)- exam

Degree Program in Maritime engineering

Turku 2019

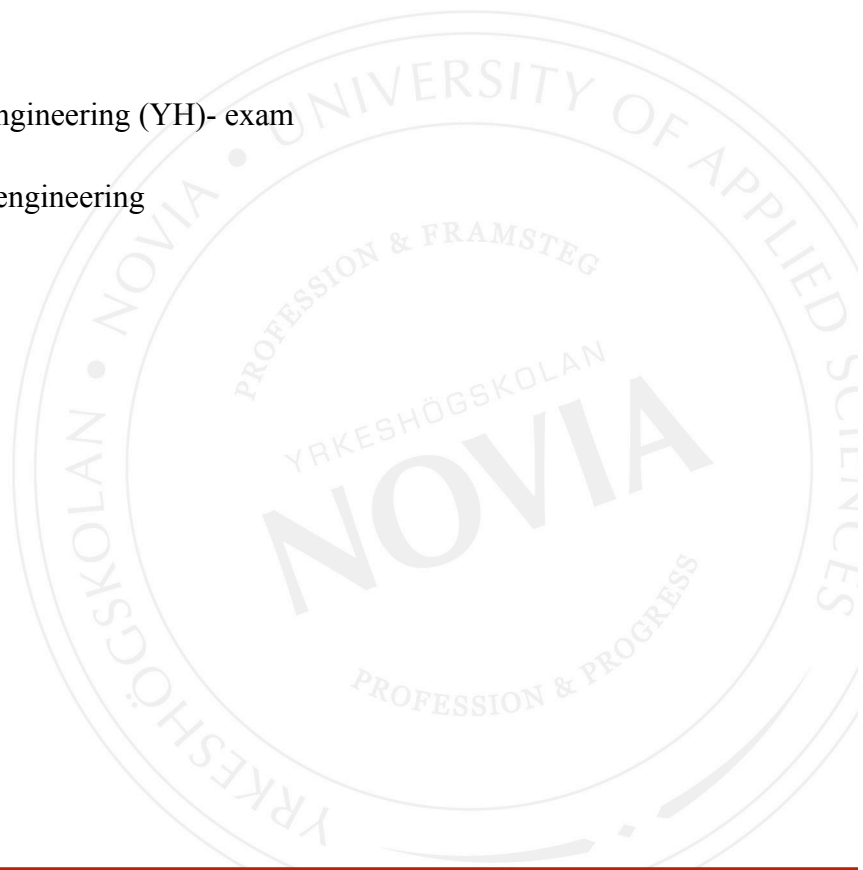

BACHELOR'S THESIS

Author: Jonas Olin

Degree Program: Maritime engineering

Supervisor(s): Peter Björkroth, Esa Lapela

Title: Auxiliary engine DO Leak tank installation onboard M/V Figaro

Date 27.01.2019

Number of pages 24 Appendices 5

Abstract

My bachelor's thesis has been a project together with the crew onboard the current vessel I work on.

I have stated a leak from the auxiliary engines, made a plan on how to minimize the loss from the leak and how to reuse the oil again without any risk of contaminating the fuel.

Within this project I have prepared the drawings for the complete system that are sent to the office for approval.

The purpose with this project have been to show how much the engine is leaking and to calculate the economic loss over the ships lifetime this far.

Language: English

Key words: Leak, diesel, tank

OPINNÄYTETYÖ

Tekijä: Jonas Olin

Koulutus ja paikkakunta: Merenkuluninsinööri, Turku

Ohjaaja(t): Peter Björkroth, Esa Lapela

Nimike: Auxiliary engine DO Leak tank installation onboard M/V Figaro

Päivämäärä 27.01.2019

Sivumäärä 24

Liitteet 5

Tiivistelmä

Opinnäytetyöni on tehty projektina laivalla missä minä olen töissä.

Minä olen varmistanut vuodon apukoneissa ja tehnyt suunnitelman, miten minimoidaan vuoto. Lisäksi olen suunnitellut, miten voidaan ottaa öljy talteen ilman että vaarannetaan polttoaineen saastuttamisen.

Tässä projektissa olen tehnyt kaikki piirustukset järjestelmästä ja lähettänyt ne konttoriin hyväksyttämistä varten.

Tämän työn tarkoitus on ollut näyttää miten paljon apukoneet ovat vuotaneet ja laskee taloudellisia menetyksiä laivan elämän aikana, tähän mennessä.

Kieli: Englanti

Avainsanat: Vuoto, diesel, tankki

EXAMENSARBETE

Författare: Jonas Olin

Utbildning och ort: Sjöingenjör, Åbo

Handledare: Peter Björkroth, Esa Lapela

Titel: Auxiliary engine DO Leak tank installation onboard M/V Figaro

Datum 27.01.2019

Sidantal 24

Bilagor 5

Abstrakt

Examensarbetet har varit ett projektarbete ombord på fartyget jag är anställd på.

Jag har säkerställt läckaget på våra hjälpmaskiner och gjort en plan på hur man kan minimera förlusten från läckaget. Därtill har jag planerat hur man kan ta oljan tillvara utan risk för att kontaminera oljan.

I det här projektet har jag gjort upp ritningar för hela systemet och skickat in dem till kontoret för godkännande.

Syftet med detta arbete har varit att påvisa hur stort läckaget i våra hjälpmaskiner har varit och att göra en beräkning på den ekonomiska förlusten för fartyget så här långt.

Språk: Engelska

Nyckelord: Läckage, diesel, tank

Table of content

- 1 Introduction..... 1
 - 1.2 Background 1
- 2 Project vessel 2
 - 2.1 Vessel Particulars 2
 - 2.2 Auxiliary engines 4
 - 2.2.1 Technical specifications auxiliary engines 5
 - 2.2.2 Alternator 5
 - 2.2.3 Turbocharger 5
 - 2.2.4 Fuel oil 6
 - 2.2.5 Lub. Oil for engine & turbochargers 6
 - 2.2.6 Lub. Oil for governor..... 6
 - 2.3 Fuel system..... 7
- 3 Identifying the problem..... 8
 - 3.1 Problem 8
 - 3.2 Solution to the problem 8
 - 3.3 Determination if there is a leak 9
 - 3.3 Leakage 10
 - 3.3 Determination of the volume leaked 10
 - 3.4 Cost calculation 11
 - 3.5 Diesel leak oil tank 14
 - 3.5.1 Description of the leak oil system down to the tank..... 14
 - 3.5.2 Leak oil tank 15
 - 3.5.3 The leak oil system after the tank 15

3.5.4 Three sensor float switch.....	16
3.5.5 Air operated transfer pump.....	16
3.5.6 Electrical diagram.....	17
4 Conclusion	18
References.....	19
Appendix 1.....	20
Appendix 2.....	21
Appendix 3.....	22
Appendix 4.....	23
Appendix 5.....	24

1 Introduction

I started working for Wallenius in the end of 2007 as a repairman. Year 2010 I went back to school and studied to become a watch keeping engineer. I finished school and have been working in Wallenius since 2014 as third engineer. I have been working onboard around 10 different Wallenius ships. Some of the ships were equipped with Wärtsilä 32 as auxiliary engines. The newer ships have been equipped with auxiliary engines from MAN STX. I enjoy my work as an engineer very much since it gives me freedom to plan my work and improve the ship I'm working on as well as finding ways to save some money.

Shortly explained, this thesis is about the fuel leaks of the engines. In the manual of Wärtsilä's engines you could read that all engines of different sizes have a certain amount of fuel leaks from the fuel pumps on the engines. However, in the manual for Man STX engines I couldn't find anything stated about any leaks. So since the engine sizes aren't far from each other I thought that it could be interesting to check if there are any leaks and how big that leak is. The ship were I perform these calculations is named M/V Figaro and is on the present day a little older than seven years. Bear in mind when you look at my calculations for the cost loss, that the sum is theoretical since there is no way to prove that the leak has been constant since the beginning.

1.2 Background

I have seen these tanks on several of the ships equipped with Wärtsilä engines, but also on a few of the newer ships equipped with MAN STX engines, but when you ask around how much the leak is and how big the loss have been, nobody onboard can give any answer. So me and the chief engineer, on the current ship were I am employed, decided that this would be a good project to measure and do a theoretical calculation on how big the economic loss have been. We already know that the Wärtsilä engines has a certain amount of leak from the fuel pumps, since that is stated in the manual. If the Wärtsilä engines has a given leak what says that the MAN engines doesn't have? This thesis is about finding out about the leaks in the MAN engines and to present some figures that would motivate the ship owners to install these

tanks from newbuilding and to make sure that all older ships have one installed. I will present a written work including the class standards for such a system retrofitted on the ships and updated drawings as well to bring some clarity on how the system is built.

2 Project vessel

The vessel M/V Figaro is owned by the stock listed company WWL ASA and is managed by Wallenius Marine. Figaro was built in Korean Okpo and delivered 26 of September 2011. Her ship type is large car and truck carrier (Lctc) and is capable of loading 7789 cars of size rt32 (standard measurement of a small car). Figaro normally sails worldwide with different kind of cargo, carrying everything from cars to mining equipment.

Figaro is equipped with one main engine of crosshead type Doosan/MAN B&W 8S60ME-C8. That is a type of slow steaming engine with a max rpm of 110rpm. She is also equipped with a shaft generator that produces electricity while the main engine is running over 75rpm. Always when running slower than 75rpm the auxiliary engines will start and produce the electricity. The auxiliary engines are also in use while navigating narrow seas and where there is a lot of traffic and you have to slow down quite quickly.

2.1 Vessel Particulars

TECHNICAL SPECIFICATIONS

Length over all	227,8 m
Length between perpendiculars	219,3
Beam, moulded	32,26 m
Air draught, ab. ballast water line	44,1 m
Height to upper deck	34,7 m
Draught, design/max	10,3/11,3 m
Deadweight at maximum draft	30 900 ton

Gross Tonnage	74 258 ton
Net Tonnage	26 158 ton
Stern ramp width	9,5 m
Stern opening height	6,5 m
Stern ramp capacity	320 ton
Built	Daewoo Shipbuilding & Marine Engineering, DSME #4457, 2011, Okpo, Rep. of Korea SMGW
Flag	Swedish
Number of car decks	13 (of which 5 are movable)
Capacity deck area	~66,600 m ²
Capacity of car units*	7,879
Capacity of cars/buses	3,508/432
Engine	Doosan/MAN B&W 8S60ME-C8
Call sign	SMGW
IMO Number	9505027



Picture 1. A picture of M/V Figaro

2.2 Auxiliary engines

The auxiliary engines on the vessel have a purpose to produce electricity when the ships shaft generator is disconnected or if the vessel doesn't have one. On Figaro we have a shaft generator and the auxiliary engines are normally running during pilotage, anchorage, port stay or if the ship is navigating in narrow seas. The auxiliary engines are two diesel engines equipped with a generator aft of the motor and is connected with coupling directly to the engine. Figaro's auxiliary engines are of manufacturer MAN STX and are a four stroke in line engine with nine cylinders with a size of 21 mm. The engines are intermediate speed engines.



Picture 2. This pictures shows the auxiliary engines. (photo Jonas olin)

2.2.1 Technical specifications auxiliary engines

Engine model	9L21/31
No. of cylinders	9
Cycle	4-stroke
Diameter of cylinder	210 mm
Stroke of piston	310 mm
Rated output	1800 kw
Rated speed	900 rpm
Max firing pressure	200 bar
B.M.E.P	24,8 bar
Compression ratio	16.5 : 1
Rotation direction	C.W view from flywheel

2.2.2 Alternator

Maker	Hyundai heavy ind.
Type	HFJ7 638-84K
Capacity	2125.0 KVA
Efficiency, $\cos \phi=1.0$	93,5% / 95,8% / 96,2% / 96% / 95,8%
	25% / 50% / 75% / 100% / 110%
Voltage	450 V
Current	2726,4 A
Frequency	60 hz
Power factor	0,8

2.2.3 Turbocharger

Maker	MAN
Type	TCR18

2.2.4 Fuel oil

Name	Marine diesel oil
Specific gravity	0,8648 (@15/4°C)
Viscosity	10.5 (CST @40.0°C)
L.C.V	10161 Kcal/kg

2.2.5 Lub. Oil for engine & turbochargers

Name	Daphne marine oil sx-40
Specific gravity	0.8928 (@15/4°C)
Viscosity	130.1 (CST@40.0°C)

2.2.6 Lub. Oil for governor

Name	Dn super hydraulic fluid 68
Specific gravity	0.8730 (@15/40°C)
Viscosity	66.890 (CST @ 40.0°C)

2.3 Fuel system

The vessel's auxiliary engines are built to be able to run on both HFO (heavy fuel oil) and diesel oil. This means that the vessel has two different systems for the different fuel types. We are though able to run diesel in the HFO system so we can use the advantage with that system, such as heat exchangers that we use to cool the diesel oil down and get the temperature as close to 30°C as possible.

The fuel system is built as follows: you have one service tank that stores the cleaned fuel that is ready for use. From the service tank the fuel will go the supply pumps that increases the pressure and pumps it forward through a flowmeter to a mixing tank. The mixing tank is used to get the air out from the system, or if shifting fuel between HFO and diesel oil. After the mixing tank the fuel will continue to circulating pumps that raises the pressure a bit more to make sure that the engines have enough fuel for their different loads. After the circulating pumps the fuels go through the heat exchangers. Since we are running on diesel oil we use them as coolers to keep the diesel temperature between 30- 40°C. From the heat exchangers the fuel passes through the automatic filter that will clean out the smallest particles from the fuel oil. After that the fuel passes through a viscosity meter that we don't have in use and from there it goes to the engine. Since we have an oversupply with fuel to the engines, the extra fuel that doesn't go in to the combustion chamber, will go in a return line back to the mixing tank.

When the auxiliary engines get a start signal from the ships engine control system, one of the supply pump and one of the circulating pump will start and the fuel will start to circulate in the fuel system for both engines. Both those pumps will run as long as the auxiliary engines are running. As long as we are running on diesel, the pumps will stop a little while after the auxiliary engines have come to a stop and then they will stop automatically. If we were running on HFO they would run continuously. The reason for that is that the HFO won't cool down in the fuel system so that the viscosity would rise and the oil would get very thick and clog the system.

3 Identifying the problem

3.1 Problem

Before the auxiliary engines starts, the supply and circulating pumps starts to pressurize the fuel system on both auxiliary engines. When this happens, some fuel will also start to leak from the fuel pumps. This fuel will go down to a leak cup that is located on the side of the engine. From this leak cup the fuel will drain automatically down to the FO drain tank where it will be mixed up with all the other fuels that might come from the main engine, the scuppers around the main engine and from the hotbox (compartment around the fuel pumps that is covered with hatches) on the auxiliary engines. Today, both the drain from the hotbox and the leak pipe from the fuel pump is put together into one pipe that continues down to the leak tank on the side of the auxiliary engines. With this solution you'll get all other leaks that might occur, down to the leak tank from where it goes straight down to FO drain tank and you can get all kinds of mixtures in the drain tank. Also when we get the drains from the main engine and it's scuppers you will get down HFO to the drain tank. Since the ship sails in SECA (Sulphur emission controlled areas) it is not possible to pump it back up to the diesel settling tank (a diesel tank where the fuel is stored after it comes from the big storage tanks and before the purifiers will clean it) and also because we cannot guarantee the viscosity of the content in the drain tank and since we don't have any heater in use for the auxiliary engines. This will make the content of the drain tank unusable as diesel oil is quite often pumped ashore as sludge (waste oil, residues from HFO, diesel oil and lube oil).

3.2 Solution to the problem

Now we have identified the problem and that there actually is a leak of certain amount in the fuel pumps of the engines. The next step in the process is to figure out how we can collect up the clean fuel oil that leaks from the fuel pumps on the auxiliary engines in the best possible

way. We already know that the leak pipe from the fuel pumps comes out aft on the auxiliary engines and is connected with the pipe that comes from the hotbox. The easiest way is to disconnect the pipes from each other and keep the pipe that goes to the leak cup on the engine as it has been earlier. Then we connect the leak pipe from the fuel pumps to a new pipe that we will trace one deck down under the floor to a newly built DO leak tank. The newly built leak tank would collect the fuel that leaks during the time the supply and circulating pumps are running. From the tank there should be a pump that pumps the leaked diesel oil back up to the settling tank through a flow meter so we can monitor the leak and see if it increases. The tank itself should be of easiest construction and suitable size so it can be manufactured in the ships workshop and later on mounted into its place. The tank should though fill all requirements from the classification group that applies for the vessel.

3.3 Determination if there is a leak

To determine the leak, we have used a used manual method. We have traced the pipe that comes out from the hotbox and the fuel pump leak pipe and figured out where they come together and disconnected the pipes from each other. When they were disconnected we started the supply and circulating pump. When the pumps were running we put a sampling bottle under the pipe and started the stop-watch. To determine that the leak was constant, no regards if the auxiliary engine was running or not, we proceeded with two tests. The first test was performed as the engine was at standstill and the other test was performed as the engine was running. The leak time was one minute with only the pumps running and another minute with the engine running. The leak test was performed on both auxiliary engines.



Picture 3. Here it's shown how we measured the size of the leak. (Photo. Jonas Olin)

3.3 Leakage

The leak test gave the result as we suspected. There was a leak no regards if the engine was running or at standstill. The leak was measured to be 50ml per minute per engine.

3.3 Determination of the volume leaked

Now we have determined the size of the leak. With the right information we calculate the theoretical leak over the ship's life until 26.11.2018. The information we need for this is the running hours for the supply and circulating pumps. We also use the supply pumps running hours and add together both pumps running hours. We need to convert the running hours into minutes and that number we multiply with the total leakage from both engines.

Total running hours of supply and circulating pumps:

Inboard supply pump	16 405,9 hours.	26-11-2018
Outboard supply pump	11 973,2 hours.	26-11-2018

We change these hours into minutes.

$$16\,405 \times 60 + 56 = 984\,356 \text{ minutes}$$

$$11\,973 \times 60 + 12 = 718\,392 \text{ minutes}$$

Then we add them together.

$$984\,356 + 718\,392 = 1\,702\,748 \text{ minutes, total running minutes for both supply pumps.}$$

Now we take the total leak per minute and multiplies it with 100 so we can get the total volume in ml.

$$1\,702\,748 \times 100 = 170\,274\,800 \text{ ml of leaked fuel over 7,08 years.}$$

To create a better overview, we divide the total volume with 1000 so we get the volume in liters.

$$170\,274\,800 / 1000 = 170\,274,8 \text{ liters.}$$

The running hours are gathered from the ships control system Kongsberg on 26 of November 2018.

3.4 Cost calculation

To find out the loss for the fuel leaked we have converted the volume into metrical tons, since the market prices for bunkers are normally given in price per metrical ton. I also have calculated two alternatives to give a picture of the economic loss for the ship.

First alternative is that the leaked fuel that is collected in the FO drain tank, is discarded and pumped ashore as sludge. This is the least economic way to proceed but it is a safe way if you cannot guarantee what is collected in the drain tank.

The second alternative is to pump the oil from the drain tank out to a bunker tank and use it as HFO. This can be done but there is always a risk that you contaminate the oil in the tank and if you are not sure about the content in the tank it is not recommended to do so.

To calculate the mass of the volume we use a density of 0,85 kg/liter for the diesel oil.

Calculations:

$170\,274,8 \times 0,85 = 144\,733,58$ kg, the total volume in kg.

We still need to convert it into tons to calculate the value of the leaked fuel.

$144\,733,58 \times 1000 = 144,73$ tons leaked diesel oil.

I have gathered fuel prices from 12 months and calculated an average price for both MGO and IFO 380.

Average price IFO 380	678,2 \$
Average price MGO	920,8 \$
Price difference between IFO 380 and MGO	242,6 \$

Alternative 1.

We pump all the oil from FO drain tank ashore as sludge

$144,73 \text{ MT} \times 920,8\$ = 133\,267,4 \$$

Alternative 2. We pump the oil from FO drain tank out to a bunker tank and reuse it as HFO.

$144,73 \text{ MT} \times 242,6\$ = 35\,111,5 \$$

These calculations show the loss for 7,08 years. To argue for the leak tank and to calculate the payback time for the tank it is easy calculate an average over the ship's life time.

Alternative 1.

$133\,267.4\$ / 7.08 \text{ years} = 18823.1\$ \text{ per year until } 26.11.2018$

Alternative 2.

$35\,111.5\$ / 7.08 \text{ years} = 4959.25\$ \text{ per year until } 26.11.2018$

3.5 Diesel leak oil tank

The best way to save is not to waste. Instead of wasting the diesel oil leaked from the auxiliary engines you should make a tank that could gathered all the clean diesel oil and you would save.

All tanks onboard a ship needs to be classified or have an approval from the classification company. In this case with the diesel leak oil tank, the guidelines are that we update all existing drawings in question for the auxiliary engines and make a drawing of the new system of diesel leak oil tank. I will present the drawings to our office and they will send it to Lloyds for approval.

3.5.1 Description of the leak oil system down to the tank

The system is built to only collect diesel oil which is leaking from the fuel pumps on each auxiliary engine. To be certain that you only will get clean diesel oil to the leak tank, it is necessary to separate the drain pipe from the hotbox and the fuel pump leak pipe.

The separation of the two lines from each other is done by a three-way valve, so it possible to reconnect to the original system.

From the three-way valve the pipe goes to a flexible hose which purpose is to absorb the vibrations and movement from the engine. This hose prevents the pipes from cracking and allows the engine to have its movements.

When the pipe goes through the deck it will be necessary weld a support, a doubling with steel to make sure that strength in the deck will remain the same.

Below the deck the pipes from both auxiliary engines will join together before connecting to the tank.

3.5.2 Leak oil tank

The leak oil tank will be fabricated onboard by the ships repairman. The tank is constructed of 8 mm steel. With base size 400mm x 500mm and the height 500mm, it will add up to 100 liters counted on the outside measurements. The reason we keep the tank below 100L is that the information I have received from our office, about the regulations on the safety equipment, on the tank is lower and makes the work in constructing the system much easier and cheaper.

The tank is built with a removable cover so it is easy to open up and clean. The cover will be of same thickness as rest of the tank and connected to tank with M12 bolts and they will be divided with a cc of approx. 150mm.

The overflow pipe will have a double function as overflow and as ventilation pipe. The pipe will be of size 1 ½” and is to be connected to the pipe that goes down to the FO drain tank. It is of outmost importance that the pipe will be connected on the top of the pipe, to prevent fluids from the drain pipe to pour down to the leak tank.

On top of the tank there will be mounted a three sensor float switch that has three tasks - it is high level alarm, pump start and pump stop. Since the pump will start and stop automatically it is very important that there is a high level alarm so the crew onboard can monitor if the starting of the pump for some reason fails. A long run alarm to the pump will also be connected, so if you get a bigger leak inside any of the fuel pumps the engineers will be notified.

3.5.3 The leak oil system after the tank

The outlet pipe from the tank will be of size 1” and is connected to a ball valve and from there it will connect to the transfer pump. From the pump the pipe is connected to a flexible hose which purpose is to absorb the vibrations and movements from the pump. From this, the pipe

will proceed up through the deck into the auxiliary engine room and is to be connected to the pipe before the auxiliary engines return fuel flow meter.

3.5.4 Three sensor float switch

The float switch is of type three level float switch. The switch has three floats, and three sensors inside a tube. The floats have magnets inside of them and when the magnets get in contact with the sensor the sensor will send a signal. The switch has three sensors which everyone has a task of its own. The top sensor is the high level alarm and will send a signal to alarm relay, the second from the top is the pump start and it will send a signal to the relay for the pump start and the last sensor is for pump stop and when the float floats down and gets contact with the sensor it will send a signal to the pump stop.

3.5.5 Air operated transfer pump

The transfer pump from the tank will be an air drive double diaphragm pump. This type of pump is known to be very reliable and is not sensitive for dry running.

The pumps working principle is that you have two diaphragms and a shaft connected between them. The shaft is made with tracks for O-rings so when the air flows the shaft moves from side to side, which moves the diaphragms and creates a suction on one side and discharge on the opposite side of the pump. There are two balls on each side of the pump. The purpose for these balls are to work as non-return valves. As the pump creates suction the upper ball will close and prevent air to leak down from the discharge side of the pump. When the pump discharges the ball the suction side closes to prevent the liquid from being pushed to the wrong direction.

3.5.6 Electrical diagram

The power supply to this unit is connected via a transformer to the same power supply as the ships sludge pump, the transformer lowers the voltage from 440 volts to 220 volts.

The circuit is built with one local emergency stop as well as one emergency stop outside the engine room. The emergency stop outside the engine room is connected to the 440 power supply.

The system is built with a push button that closes the circuit and activates the switch for automation.

When it runs automatically there is a pump start float that closes the circuit and the current goes to the relay and through to the solenoid that opens the air valve for the pump.

When the level goes down in the tank and the pump stop float goes down the relay will lose its contact, the solenoid will be powerless and the air valve will close.

If the high level float goes up a signal to the alarm relay will close, and there will be a signal that goes to the original leak tank on the side of the auxiliary engine. This alarm will send a signal to the ships control system and an alarm will sound in the engine room.

If the long run timer runs out of time the signal will also be sent to the same place as the high level alarm. The difference is that there is a breaker that disconnects the power to the solenoid and the pump will stop. For this alarm there is a reset button to reset the circuit.

4 Conclusion

All engines have some amount of leak and it should be of interest for the company to find out the how big the leak is per engine. There is a lot of money to be saved in these systems and in today's economical world where every dollar saved counts. The conclusion of this thesis is an easy way to make savings with a low amount of work. This is just an extension of an existing system with a drain tank that collects the fuel oil from all of the engines in the engine room.

Before this, all the oil that leaked went down to a drain tank and was used as HFO or pumped ashore as sludge. With the system I described, the benefit will be big and the saving will be even bigger.

These savings can easily pass the company's eyes since it is normal that the management company isn't paying the fuel oil bills, but the charterer. With that considered, every ship that would have this system installed could cut the losses and the management company would be able to show lower numbers in diesel oil consumptions counted over a longer period of time.

This system is built to be fully automatic with only normal maintenance such as cleaning of the tank and readings of the flowmeter to be carried out. So with a small effort the company can save a lot of money.

As the measurements of the leak was done under quite warm conditions it is possible that colder conditions would show a smaller leak. But I am confident in that there always will be a leak as the fuel pumps get worn and the viscosity of the diesel is low.

It has been an interesting project with a lot of things to think of and to take in consideration. The down side in the end is that I haven't received any feedback from Lloyds yet but as they come the drawings might be updated if necessary.

References:

Running hours supply and circulating pumps. Kongsberg system onboard M/V Figaro (26.11.2018).

IFO 380, average bunker price. <https://shipandbunker.com/prices/emea/nwe/nl-rtm-rotterdam>, (09.01.2019).

MGO, average bunker price <https://shipandbunker.com/prices/av/global/av-g20-global-20-ports-average#MGO>, (09.01.2019).

Vessels technical specifications.

https://www.walleniuslines.com/PageFiles/1095/Figaro_NB4459.pdf, (2018-11-22)

Transfer pump. <http://www.allpumps.com.au/assets/pdf/graco/diaphragm-pumps/husky-1050-aodd-pump-operation.pdf>, (15.01.2016)

Picture 1. https://www.walleniuslines.com/PageFiles/1095/Figaro_NB4459.pdf, 2018-11-22

Appendix 1.

AE D.O LEAK TANK M/V FIGARO

Tank outside measurements: bottom 400mm x 500mm x 500mm
 Tank top removable, connected with M12 with cc approx. 150mm
 Tank material 8 mm steel.
 pipe sizes .
 Drain line from AE's 3/8" steel pipe, ISO65
 Pump suction/discharge pipe 1" steel pipe, ISO65
 Overflow/vent pipe 1" steel pipe, ISO65
 connection to waste oil pipe and FO fuel pump. Three way ball valve, BA 7620T.
 flexible hose on AE. 3/8" ptfе, metal plated.
 Flexible hose after pump after tank. 1" ptfе, metal plated.

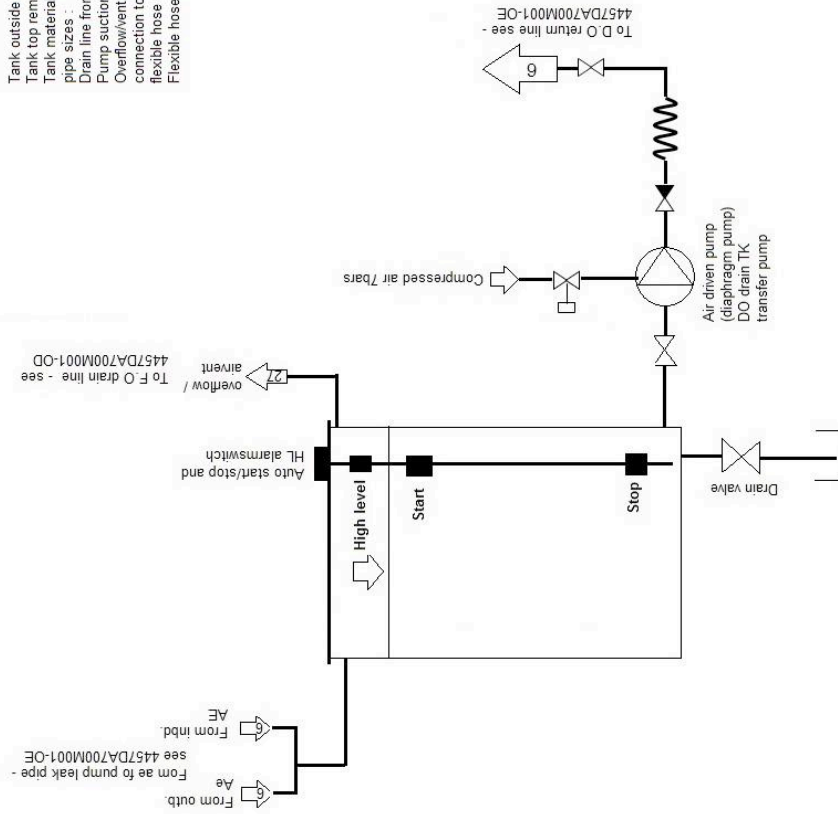

Appendix 2

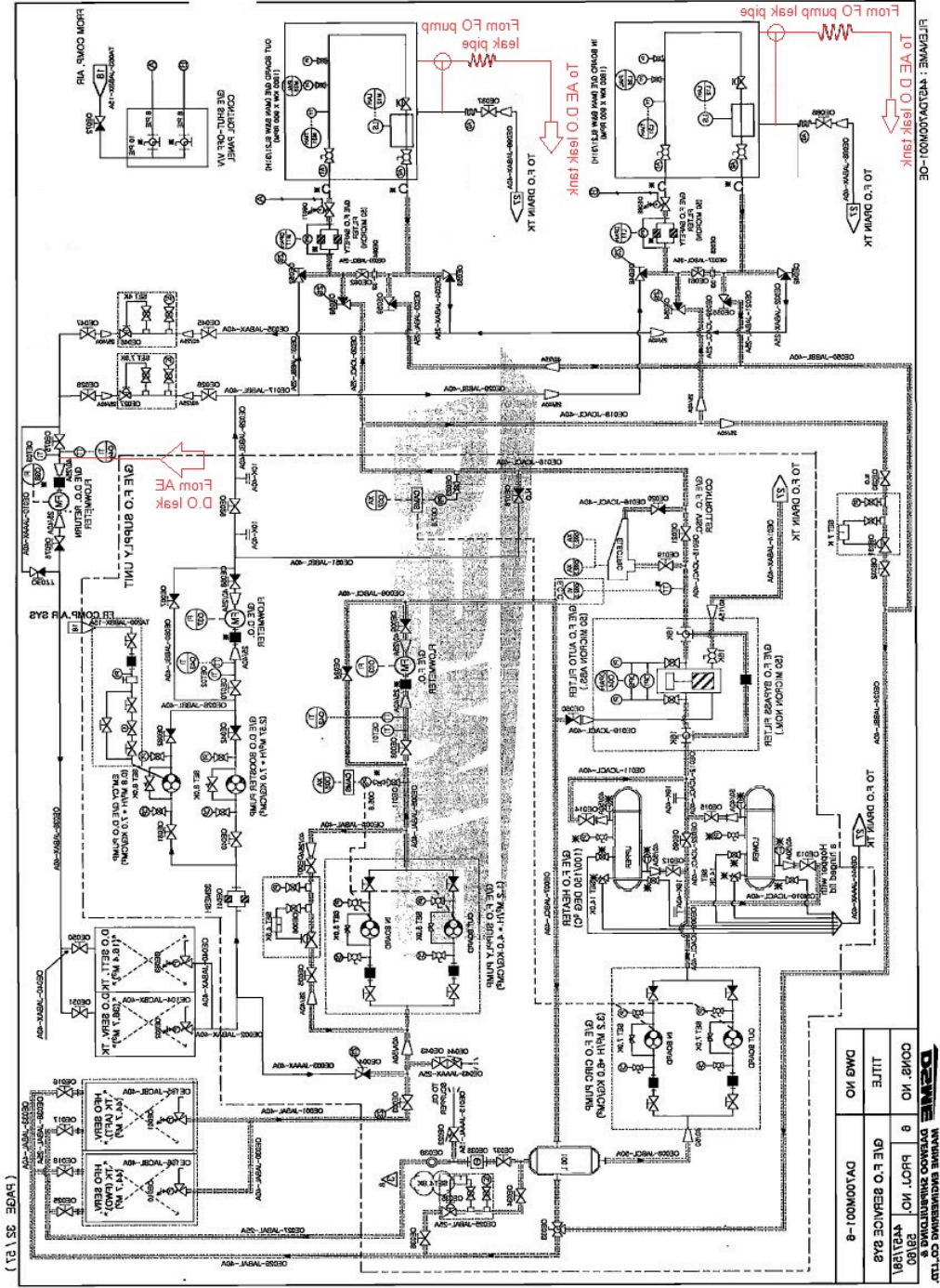

FILENAME : 431DVAL00001-0E
 2011-08-18 08:18

DEWINE		INTEGRAL ENGINEERING CORP.	
COMP. NO	8	PROJ. NO	29180
TITLE	GIE F.O. BEADICE 048	DATE	07/21/98
DMG NO	DVAL00001-8		

(PAGE 35 / 31)

Appendix 3

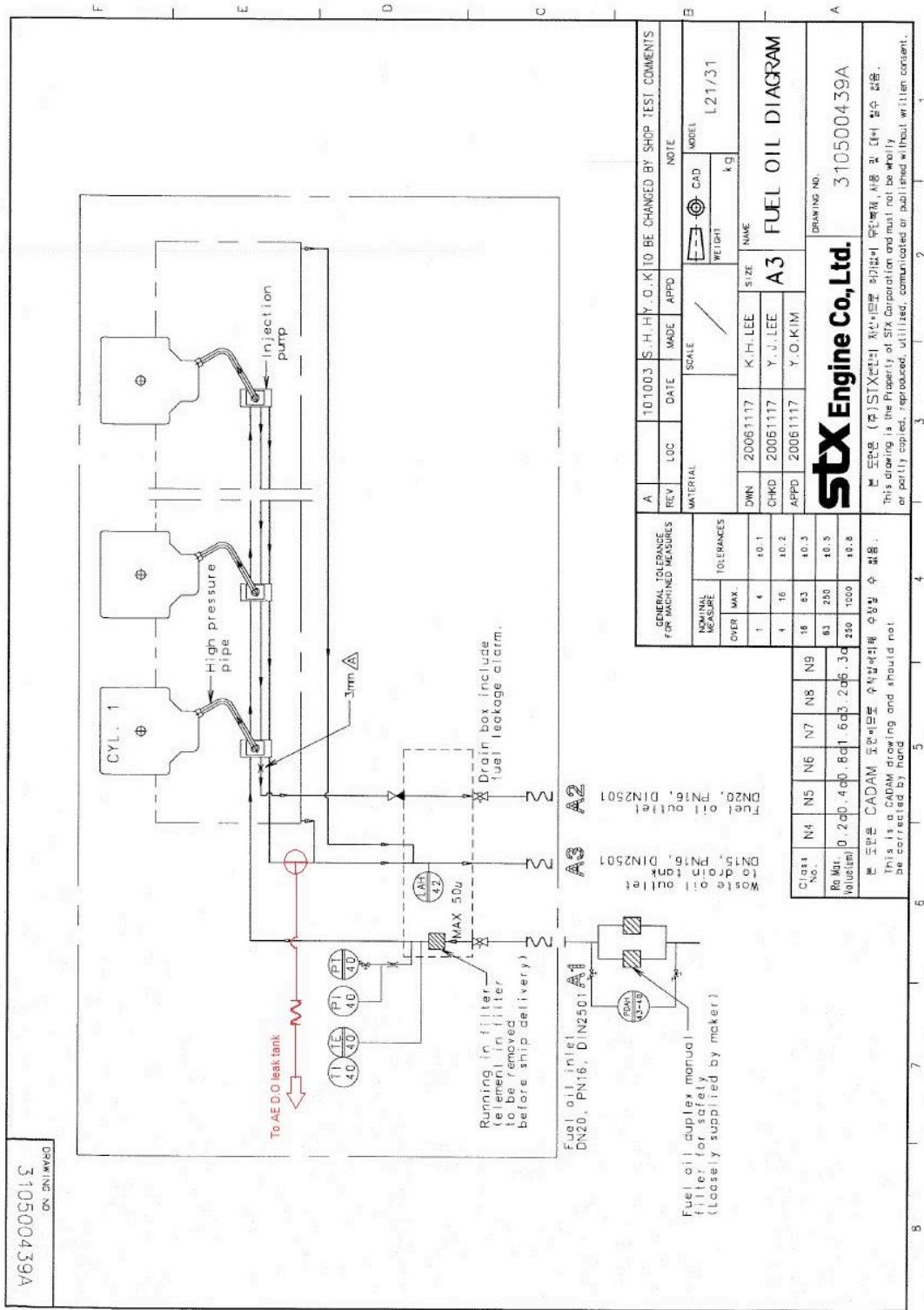

DRAWING NO.
310500439A

GENERAL TOLERANCE FOR MACHINED MEASURES		SCALE		NOTE	
NOMINAL MEASURE	TOLERANCES	DATE	MADE	APPD	MODEL
OVER	MAX.	REV	LOC	DATE	MADE
1	4	101003	S.H.H.Y.O.K	TO BE CHANGED BY SHOP TEST COMMENTS	
4	16				
16	53				
53	200				
200	1000				
1000	10.0				
10.0	10.3				

CLASS NO.	N4	N5	N6	N7	N8	N9
Ro Max. Value (mm)	0.2	0.4	0.8	1.6	3.2	6.3

CLASS NO.	N4	N5	N6	N7	N8	N9
Ro Max. Value (mm)	0.2	0.4	0.8	1.6	3.2	6.3

REV	LOC	DATE	MADE	APPD	NOTE
DWN	20061117	K.H.LEE	SIZE	A3	FUEL OIL DIAGRAM
CHKD	20061117	Y.J.LEE	SCALE		
APPD	20061117	Y.O.KIM	WEIGHT		L21/31

STX Engine Co., Ltd.		DRAWING NO.	310500439A
-----------------------------	--	-------------	------------

본 도면은 (주)STX엔지니어링의 재산으로 허가없이 무단복사, 사용 또는 기타 불수용을 행하는 것은 금지되어 있습니다. 이 도면은 STX Corporation의 재산이며 무단복사, 사용 또는 기타 불수용을 행하는 것은 금지되어 있습니다. This drawing is the Property of STX Corporation and must not be wholly or partly copied, reproduced, utilized, communicated or published without written consent.

Appendix 4

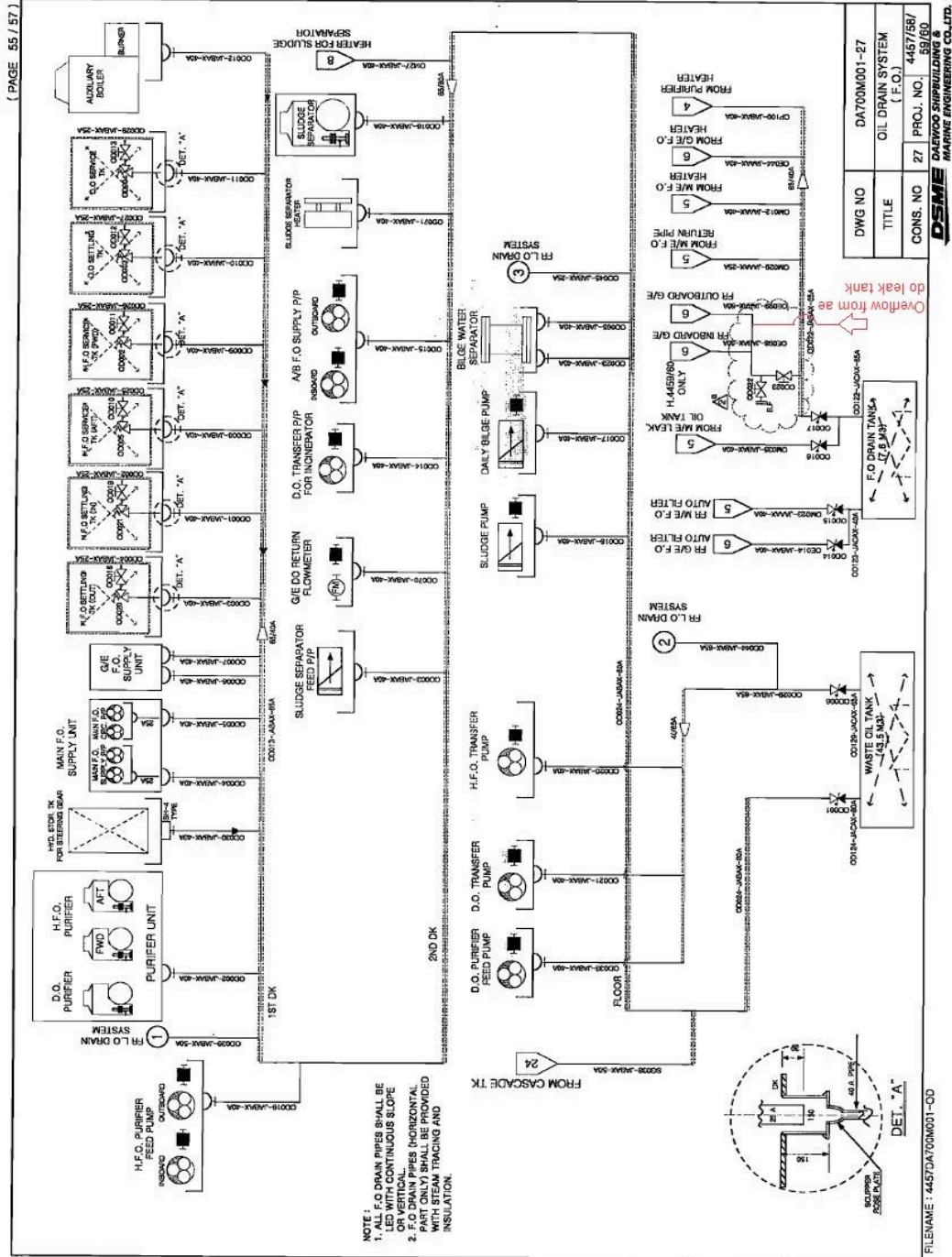

Appendix 5

CIRCUIT DIAGRAM AE D.O LEAK TANK

