

Kalle Orava

**DEVELOPMENT OF A PWC TEST SYSTEM FOR RADIATED
MEASUREMENTS**

**DEVELOPMENT OF A PWC TEST SYSTEM FOR RADIATED
MEASUREMENTS**

Kalle Orava
Bachelor's Thesis
Spring 2020
Information technology
Oulu University of Applied Sciences

ABSTRACT

Oulu University of Applied Sciences
Information Technology, Option of Device and Product Design

Author: Kalle Orava

Title of the bachelor's thesis: Development of a PWC Test System for Radiated Measurements

Supervisor: Timo Vainio

Term and year of completion: Spring 2020

Number of pages: 39

The subject of this thesis was commissioned by Verkotan, where the objective was to learn a theory behind plane wave conversion and develop an in-house software solution for Rohde & Schwarz's PWC200. The work on this subject started by researching an antenna measurement theory and examining different hardware solutions where the measurement could be automated as far as possible.

Python was chosen for a programming language for its flexibility, and suitability for a data analysis. The development of the system can be divided into two categories, calibration and measurement. Calibration is essential for later measurements, which is why it was first developed. A calibration automation program was made, it consists of PWC communications, data parsing and calibrations. The measurement program used a set of different measurement instruments to communicate different phases of the measurement.

The validation measurement between the manufacturer and the developed measurement system showed that antenna patterns are nearly identical, which proved that the system works as intended. The development took a lot of time, but it produced a working measurement system, which can be later further developed.

Keywords: OTA, Antenna, 5G, Antenna pattern

PREFACE

The work on the topic of this thesis started in early November 2019, which was commissioned to me by Verkotan. I have already been working with Verkotan before this project, which has been a huge help on this subject and altogether an interesting experience. Timo Vainio has been working as a tutoring teacher and Sami Laukkanen as the manager of this project.

I would like to thank Timo Vainio for providing guidance and help on this thesis, as well as Kaija Posio for providing help with the grammar of this thesis. I specially want to thank Sami Laukkanen and Jani Kallankari for providing help and valuable information about the subject.

Oulu, 20.02.2020
Kalle Orava

CONTENTS

ABSTRACT	3
PREFACE	4
CONTENTS	5
ABBREVIATIONS	7
1 INTRODUCTION	8
2 ANTENNA MEASUREMENT THEORY	9
2.1 Antenna measurement	10
2.2 Configuration of an antenna pattern	11
2.3 Spherical near-field measurement	13
3 PLANE WAVE SYNTHESIS THEORY	15
3.1 Problems and solutions	17
4 DESCRIPTION OF VERKOTAN'S SOLUTION	19
4.1 Description	19
4.2 Used equipment	20
4.3 PWC cabling	21
4.3.1 PWC	21
4.3.2 Peripherals	21
5 SETTING UP THE EQUIPMENT	23
5.1 Testing peripherals	23
5.2 Programming	24
5.3 Calibration setup	25
6 PWC CALIBRATION	28
6.1 Field Simulation & Calibration	28
6.2 Path loss calibration	28
6.3 Cable calibration	28
6.4 Calibration automation	29
7 PWC MEASUREMENTS	31
7.1 Validation	31
7.2 Overview of the system	32

7.3 Measurement program	33
8 CONCLUSION	35
REFERENCES	36

ABBREVIATIONS

DUT	Device Under Test
EIRP	Effective isotropic radiated power
EIS	Effective isotropic sensitivity
GUI	Graphical User Interface
IP	Internet Protocol
LAN	Local Area Network
LNA	Low-noise amplifier
MIMO	Multiple Input Multiple Output
PWC	Plane wave converter
R&S	Rohde & Schwarz
VISA	Virtual Instrument Software Architecture
VNA	Vector Network Analyzer
VSG	Vector Signal Generator
5G	Fifth generation of cellular technology

1 INTRODUCTION

Technology is evolving fast and the need for testing new wireless devices is increasing rapidly. New test methods are continuously needed while serving current customers. There must be resources to handle both development and antenna testing. This thesis subject was commissioned by Verkotan, which is a rising company in wireless testing and in need of a new method for measuring base stations. The aim of this thesis is to set-up, calibrate, validate and develop new measurement technique for Verkotan using Rohde and Schwarz's plane wave converter, PWC200. The Setting up consists of choosing and verifying the accuracy and functionality of the hardware solutions, while the rest of the tasks are done using programming. Programming tasks for this thesis are handling the data transfer between PWC and measurement instruments, as well as automating the calibration of the PWC, and programming related to the actual measurement software.

This system enables measuring base station antennas with the 5G technology. The objective is to use own software solutions, which can be later developed to support new features, rather than using Rohde & Schwarz's complete GUI software. The developed software must be flexible for a continuous improvement as well as stable and robust for measuring customer antennas. The PWC enables large antenna measurements without massive and long near-to-far-field calculations or unrealistically large anechoic chamber. The dimensions of the PWC are approximately 2 meters wide and 1.7 meters long. The whole antenna array weighs around 67 kg and consists of 216 different antenna elements. Because measurements are to be done in high accuracy, high precision must be maintained when performing instrument or cable calibrations or when analysing data. This thesis focuses on a compact range system where PWC is used.

2 ANTENNA MEASUREMENT THEORY

When analyzing antenna pattern data, there are parameters that define different characteristics of an antenna. These parameters are used daily in antenna testing, and in this section a few of them are introduced. The beam width is one of the important parameters in antenna testing, and it is the first thing you notice when viewing antenna patterns. The Term Half-power beam width is often used and it is defined as an area where main lobes power has decreased 3dB. (1) Actually, an antenna pattern image usually consists of two different patterns, polarizations. When talking about polarization related to antenna measurements, it refers to the plane which is the same as the movement of the electromagnetic wave. Antennas can only receive one type of polarized signal and as a result, antenna measurements in general need a great accuracy when mounting the DUT to mast or when designing antennas. When analyzing antenna patterns, one key parameter is the cross-polarization ratio which is the ratio between the intended transmit polarization, and cross-polarization, the unintended polarization. A larger value means a higher difference, thus a better performance transmit power wise. FIGURE 1 depicts two common types of polarizations. (2, 3)

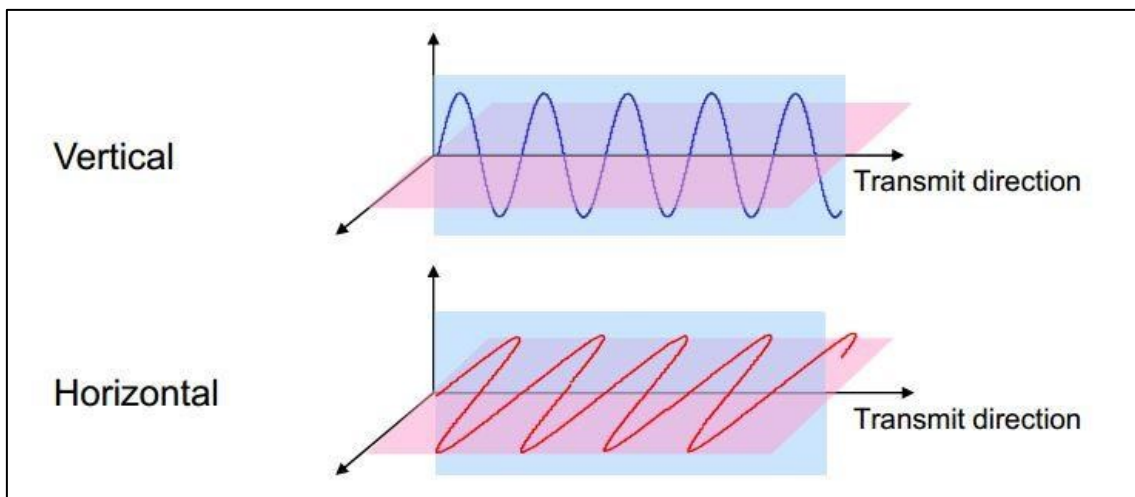

FIGURE 1. Different linear polarizations (4)

Gain is used to determine the directivity of an antenna compared to an isotropic radiator when a perfect isotropic radiator is completely sphere shaped at 0dB. High gain is not always the best solution, and different solutions benefit from different gain values. (5) When talking about 5G cellular networks, EIS and EIRP parameters are used to measure directional sensitivity and power, where EIS defines the sensitivity of an antenna in a specific direction. EIS is measured in a grid pattern. For every measurement point in the grid, data packets are sent using VSG, while decreasing the power until a specific threshold is met. (6, 7) EIRP is a parameter that characterizes directed beams radiated power by using a theoretical model of an isotropic radiator. EIRP is usually measured using a power sensor to read the transmitted power from the DUT. (7, p. 11, 8)

2.1 Antenna measurement

When conducting antenna tests, characteristics of antennas define the measurement setup. The most important parameters used are frequency and physical size of antenna. These determine the size of different radiation zones, most notably near-field and far-field zone.

The distance of a far-field zone is determined by:

$$d_F = \frac{2D^2}{\lambda} \qquad \text{FORMULA 1}$$

D = Antennas longest dimension

λ = Wavelength of the antennas used frequency

Antenna measurement results are wanted from a far-field region where the antenna pattern receives its final form, thus limiting measurement options in terms of available space. For example, if the longest dimension of a $DUT = 1$ and it operates at 3.5GHz, the far-field zone length is:

$$\frac{2*(1\ m)^2}{0.086\ m} = 23.255 \dots m \approx 23.3\ m$$

Antennas can be measured using different methods, using an outdoor system or a compact range system. In the outdoor system the most challenging part is the needed space for measurements and changing weather conditions. When using an anechoic chamber, therefore using a compact range system, there are multiple solutions available and a few of them are introduced in this thesis.

2.2 Configuration of an antenna pattern

Antennas used in telecommunications usually require a large operating distance and, for comparison a very simple dipole-antenna has low gain of 2.15dBi, which falls short of a typical base station antenna which has approximately the gain of 18dBi. The radiation pattern of a dipole-antenna is depicted in FIGURE 2. Antennas need to be configured to higher gains by making multiple element arrays, which consist of smaller patch-antennas, for example. Increasing the number of elements in antennas, arranging them related to other elements, in a specific pattern, and shifting the phase and amplitude of individual elements just in the right way, the array elements interfere with each other to produce directive beams and cancel radiation in undesired directions. The antenna pattern formed from patch-elements can be seen in FIGURE 3. (9, p. 285; 10; 11, p. 15)

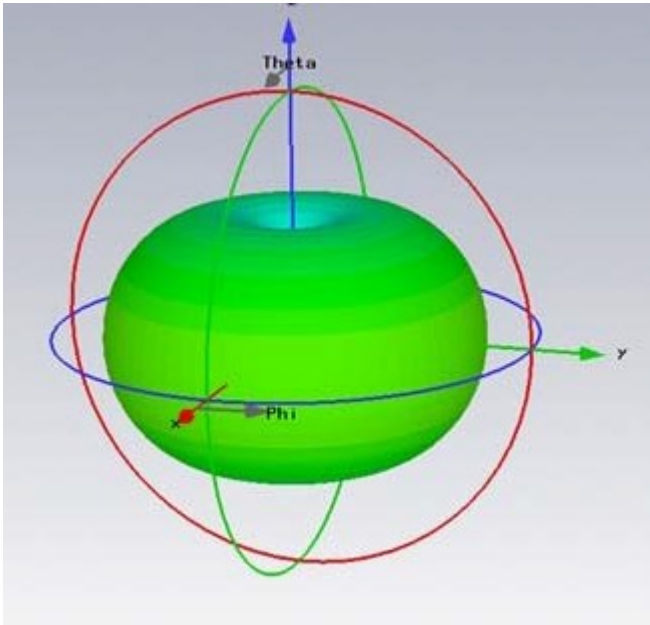

FIGURE 2. 3D-pattern of a dipole-antenna (12)

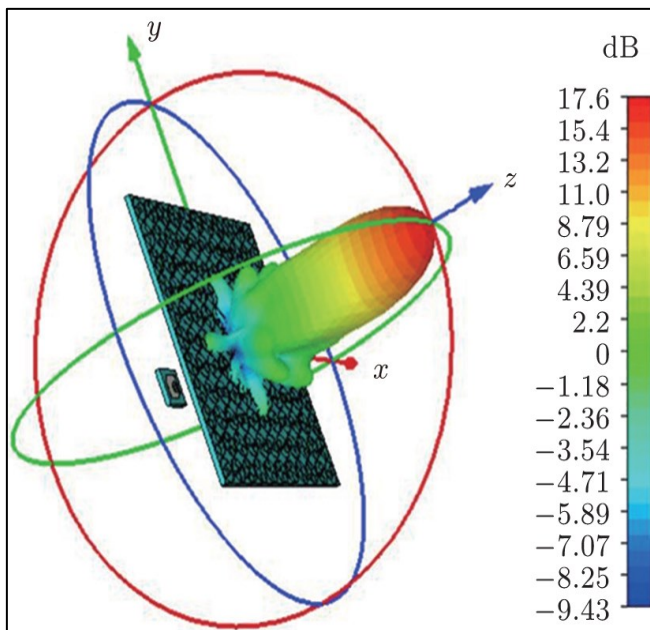

FIGURE 3. 3D-pattern of a multielement array (13)

2.3 Spherical near-field measurement

Since the far-field measurement distance in the previous outdoor example was quite large, one way to achieve same results is using a spherical near-field scanning. The term spherical refers to a probing surface of the test antenna. FIGURE 4 shows OTA chamber which is used in the spherical near-field measurement, which also shows the circular position of the probe antennas which enable a full 3D antenna pattern, with the help of rotating mast. In this type of a measurement, the DUT is measured in its near-field zone and mathematically transformed into the far-field zone, according to Maxwell's equations. Errors occurred in this method are practically only mathematical rounding errors and measurement errors. (14, p. 2.)

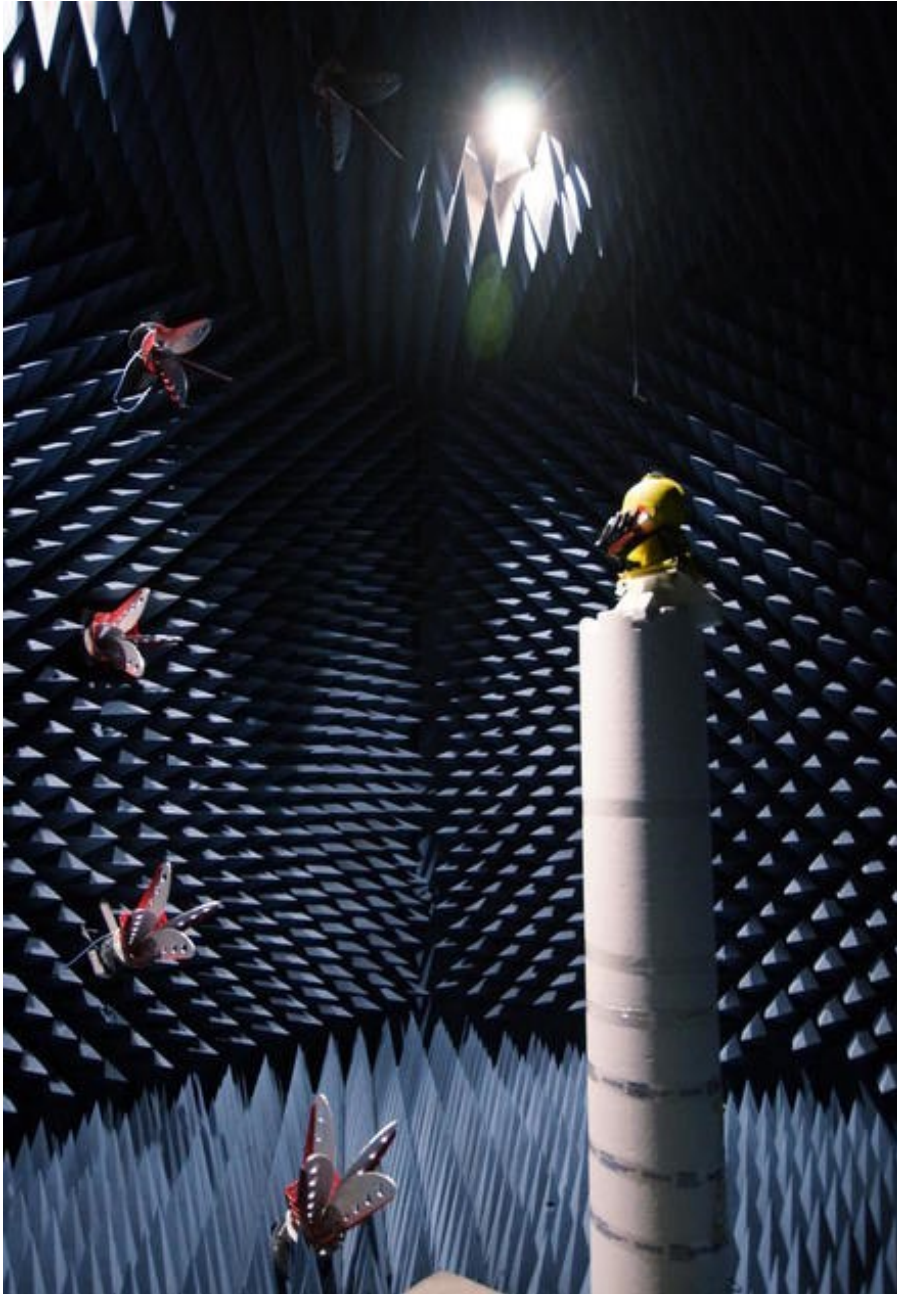

FIGURE 4. Anechoic OTA chamber (15)

3 PLANE WAVE SYNTHESIS THEORY

In the previous section 2.3, it was pointed out that when using the spherical near-field technique, it requires mathematical operations in order to transform the near-field data to far-field. In fact, the mathematical calculations can be so intense that it takes several hours of processing on a well-equipped computer. The plane wave converter solution tries to do the near-field to far-field transformation with as little processing as possible it is called a plane wave synthesis. “The plane-wave synthesis method is based on the fact that an element of the far-field pattern represents the antenna response to a point source located at a far-field distance in the direction concerned” (16, p. 246.)

The plane wave synthesis means creating a planar plane wave wavefront, which naturally only happens at a far-field region. In case where the plane wave can be created at the close proximity of the DUT, it would mean that far-field characteristics of antennas could be measured. Such condition could be made with a reflector or an array of antenna elements, and since the method does not require the actual far-field distance, it would be feasible in laboratory conditions. Verkotan’s solution uses the same type of solution, which is why the theory around the plane wave synthesis revolves around a collimator which uses an array of antenna elements. In FIGURE 5 it is depicted a simple far-field measurement where the final form of the antenna pattern is transformed with a long enough measuring distance. In the Measurement where a mirror-type solution is used, as opposed to the previous example, a compact range solution with a reflector is depicted in FIGURE 6. (17, p. 17.)

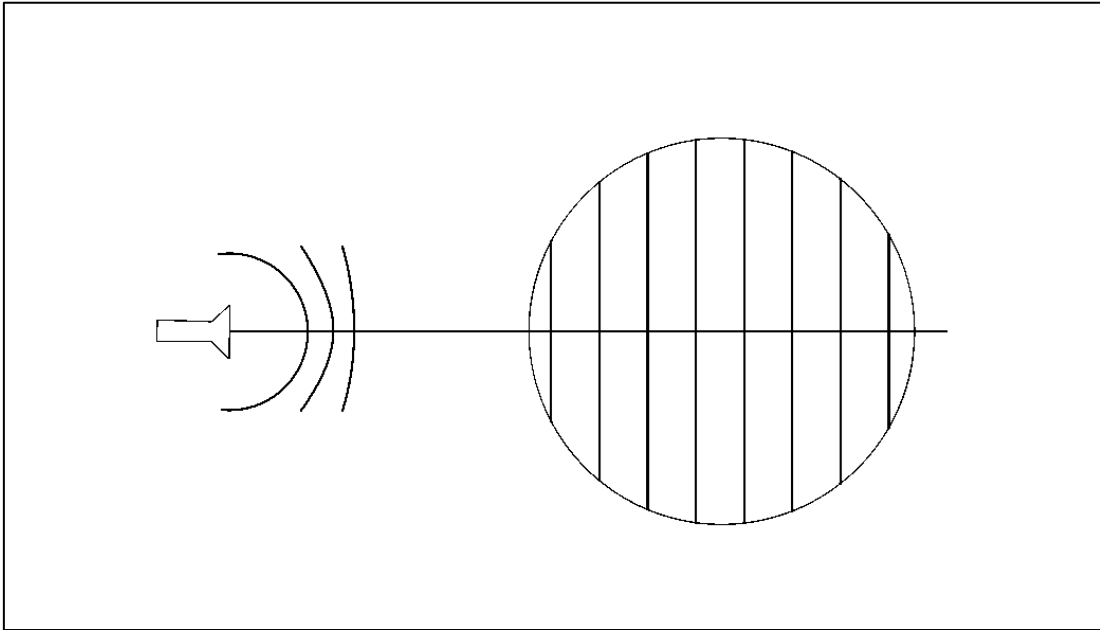

FIGURE 5. Spherical waves transform into planar form, where straight lines inside the circle represent the planar wavefront

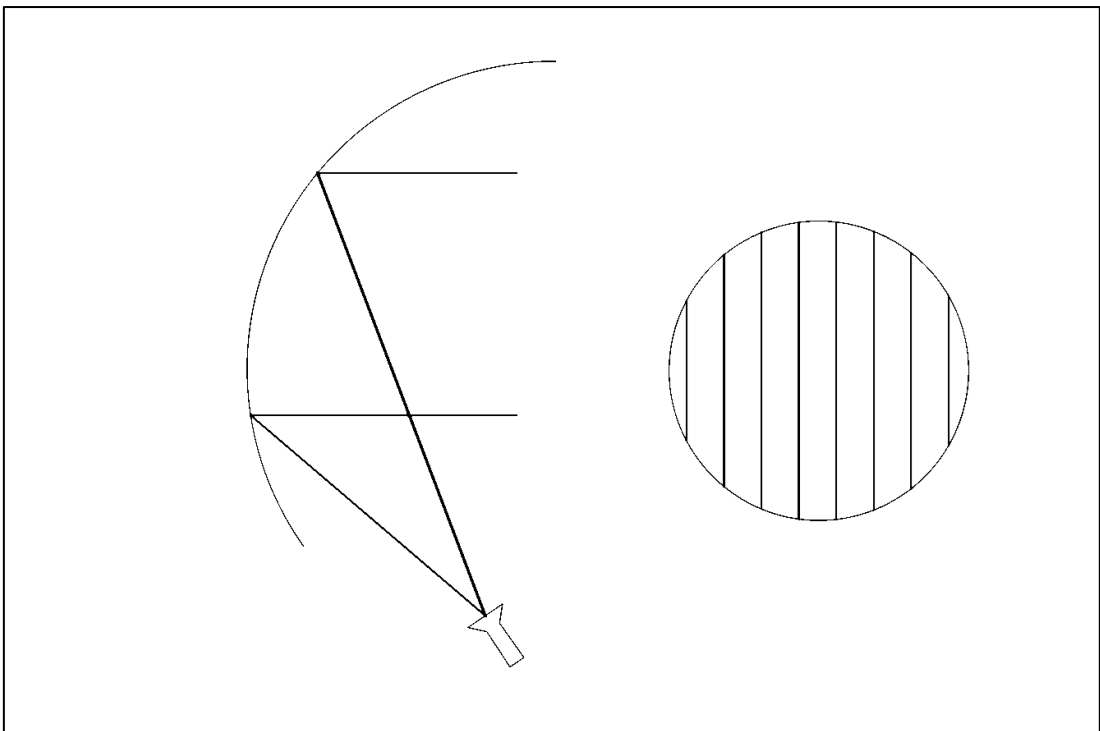

FIGURE 6. Compact range transformation of spherical waves, where straight lines inside the circle represent the planar wavefront

3.1 Problems and solutions

When thinking about the limits of the system, it can be asked that how big the test antennas can be and what limits the size. When the problem is being examined, when a test antenna is in receiving mode, it is the plane wave converter that accomplishes the plane wave that is later measured. (14, p. 294.) For measurements the DUT has to be smaller than the PWC, which limits testing for smaller antennas. A limiting factor for the quiet zone is the amplitude taper of each antenna element and edge diffraction that distorts the antenna pattern at the edge of the mirror or the PWC. Edge diffraction happens when a radiating signal hits an opening or an edge, where it behaves just like a water wave colliding with obstacles. The diffraction effect is relative to the wavelength of the signal, so that the effect is smaller as the frequency increases. (18) When edge diffraction happened because of the edges of the collimator, it caused errors directly at the angle where sidelobe was located in the antenna pattern. (19, p. 200.) A narrow amplitude taper of the antenna elements causes a wider main lobe as well as decreases the amplitude level of the sidelobes. (19, p. 206.)

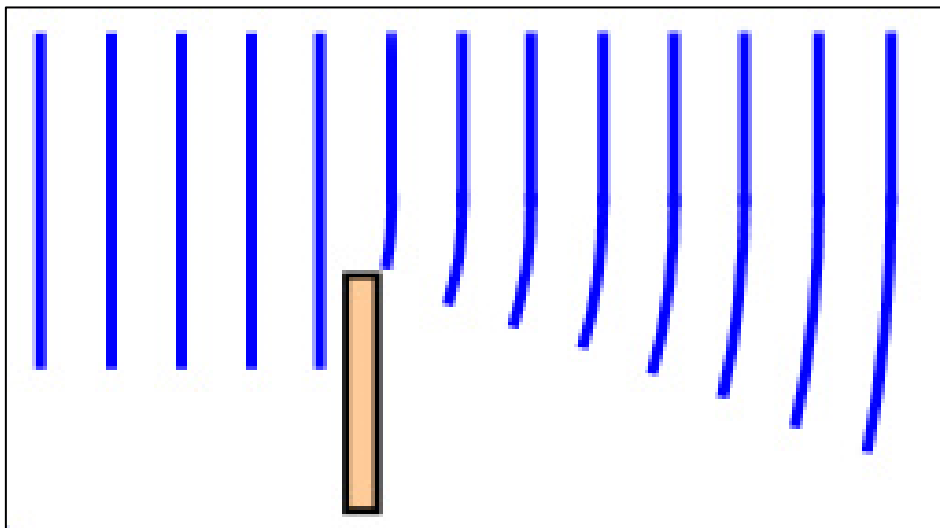

FIGURE 7. Effect of the edge diffraction (20)

Edge distortion is fixed in the PWC by applying passive antennas at the outer ring of the collimator, next to the outmost active antennas. This levels the electromagnetic environment between antenna elements near the center of the collimator and elements at the outer ring. The PWC uses precisely placed Vivaldi antennas in place of a reflector.

Vivaldi antenna are simply constructed from a copper sheet with a tapered slot. Each antenna in the PWC is placed at an exact precision with exact phase and amplitude values, while maintaining a good coupling. This fixes the previously mentioned narrow amplitude taper problem, since Vivaldi antennas have a very broad frequency bandwidth. FIGURE 8 shows the Vivaldi antenna in exploded view. (21)

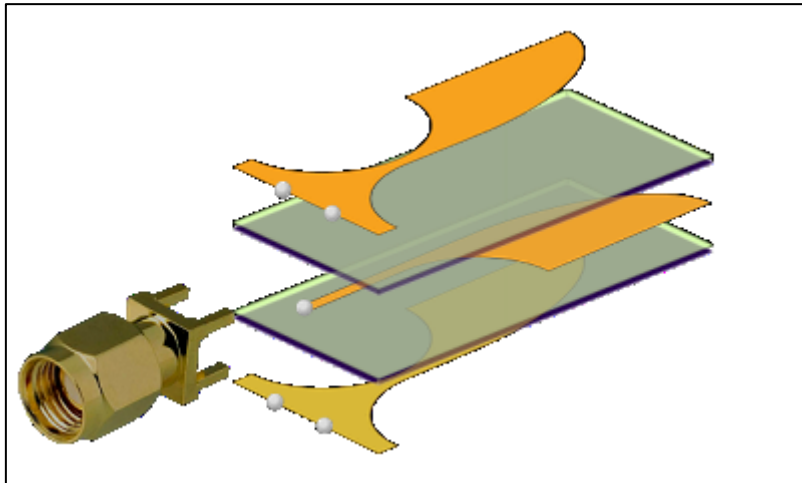

FIGURE 8. Vivaldi antenna in exploded view (22)

A further investigation of the errors caused by edge diffraction and reflections could be studied by simulating the anechoic chambers conditions.

4 DESCRIPTION OF VERKOTAN'S SOLUTION

4.1 Description

From the beginning the objective was to measure base stations with an in-house developed software solution for calibrating, measuring and analyzing data. PWC200 was chosen for its hardware based near-field to far-field transformation, which cuts a large amount of measurement data post-processing, and for its suitability for base station measurements. PWC200 is commercial product manufactured by Rohde & Schwarz and it is shown left in the FIGURE 9.

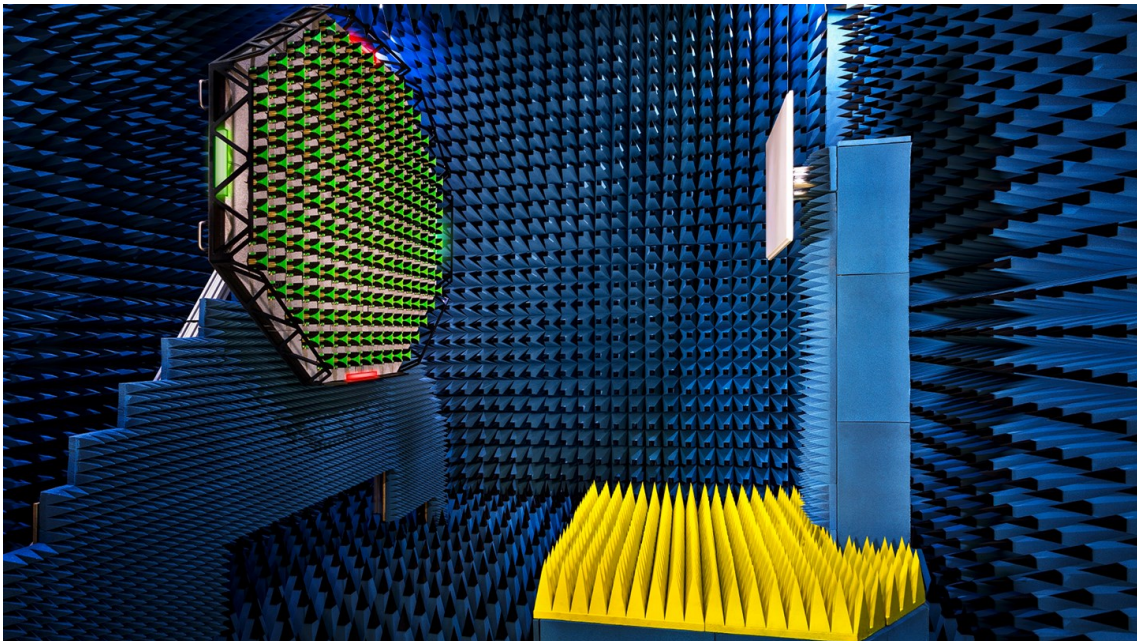

FIGURE 9. PWC200 (23)

The in-house measurement software is needed to communicate with the PWC, R&S's software and hardware, turn center mast's azimuthal and elevational angle, to control the PWC's motor, and to finally analyze and parse the data from the PWC into measurement result file and make images from the analyzed data.

4.2 Used equipment

The PWC needs multiple different equipment in order to accomplish a full calibration and to later measure customer DUTs. The full device list can be seen in TABLE 1.

TABLE 1 Device list

Device	Brand
VSG	Anritsu MG3710e
VNA	Rohde & Schwarz ZVA8
Switchmatrix	Rohde & Schwarz OSP120
Power sensor	Rohde & Schwarz NRPZ
Control PC	Custom built
Router	TP-LINK Archer C7
RF-switch	Racal 1256
PWC-motor	MAC140
Motor controller	Raspberry Pi 4

4.3 PWC cabling

4.3.1 PWC

The PWC operates at the frequency between 2.3GHz – 3.8GHz, and it is powered by 12VDC and 2.5A. Connectors at the back of the PWC are:

- Meas
- Ref
- PWR
- Control

Meas is the main port which is used when conducting antenna measurements and calibrations. An RF-cable is connected from the PWC's Meas port to the RF switch, where it can be switched to VNA or a power sensor using the control PC. The ref port is connected to only one reference antenna, which is used in the PWC's self-test measurements. The PWC uses a fiber-optic cable for communications data transfer which is handled by the OSP-120 control unit, which in turn uses a LAN connection with all the other devices.

4.3.2 Peripherals

Since customer antennas are often needed to be measured in both polarizations, this can be achieved rotating the PWC with a custom-made motor, which is attached to the back of the PWC. For monitoring the testing and ensuring that everything is working as intended, an IP camera is used. A full schematic of the wirings can be seen in FIGURE 10. The motor is controlled with a serial-connection and it is coloured black in the schematic. All Ethernet connections are coloured green, RF cables are coloured red, USB cables are coloured grey and GPIB cables are purple.

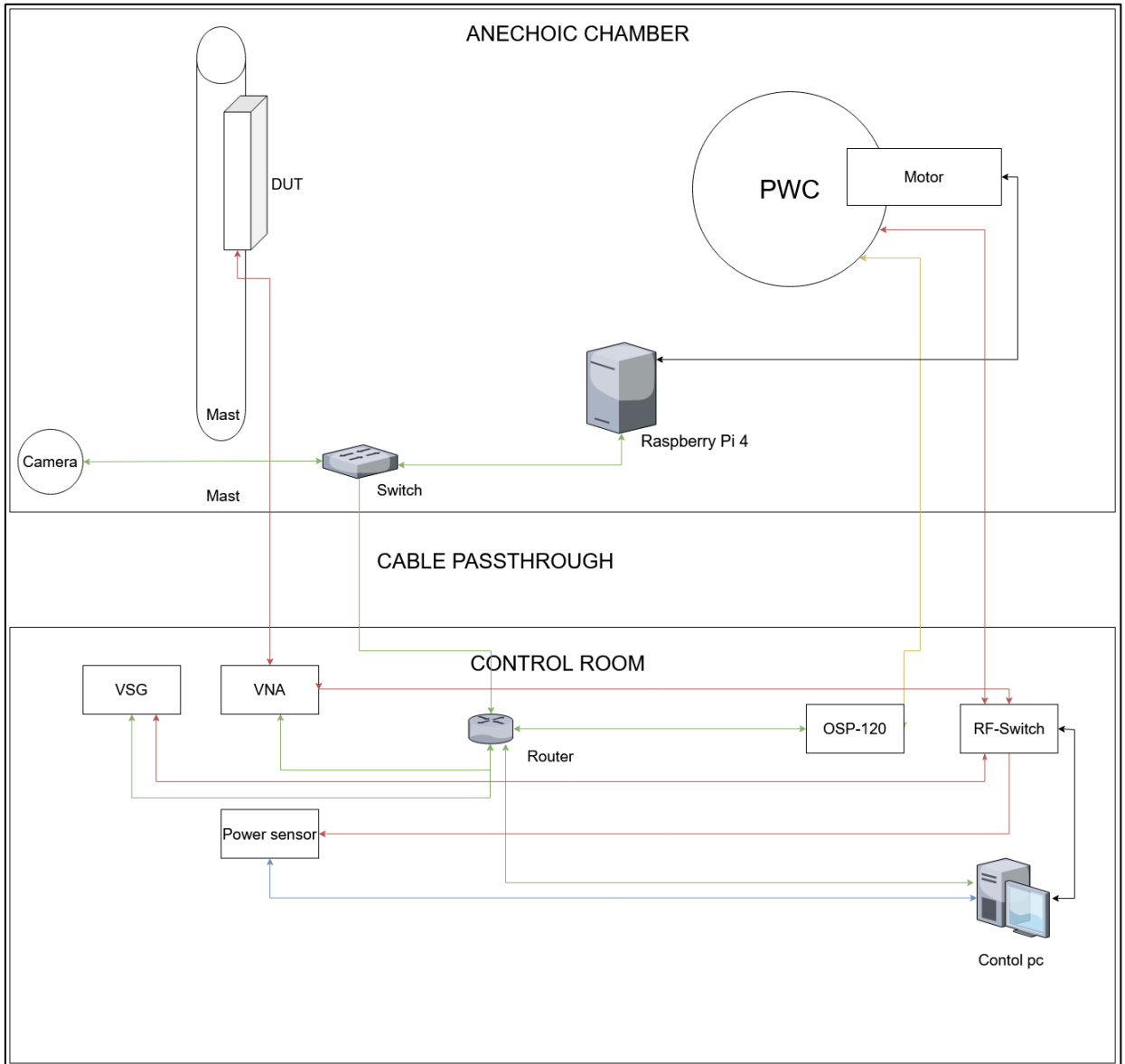

FIGURE 10. Connection diagram

5 SETTING UP THE EQUIPMENT

5.1 Testing peripherals

In order to communicate with the PWC, a connection needs to be established between devices. The Static IP address needs to be assigned to every device that supports the LAN connection, except the control PC. This is done from the router's GUI. The address needs to be static so that later built software solutions can easily find same devices from the same IP address. Raspberry Pi is set up to direct the port specific LAN traffic to the angle sensors or the motor. This is then added as a service to the Raspberry Pi, using Systemd's systemctl utility, in order to route commands to sensors and motor even after rebooting.

Because the amplitude measured from the PWC is a critical parameter in order to get an accurate and repeatable results, the cables used in the measurement instruments needs to be high-quality and stable phase- and amplitude-wise. Simply knowing that the cables are from a reputable manufacturer is not enough. Since cables could have been damaged in shipment, the cables need to be tested using VNA. Cables are connected one by one to the VNA from both ends, and the resulting signal is calculated to zero using VNA's built-in functions. In this way the difference in amplitude and phase can be seen when slightly bending the cable.

Measurement cable from the PWC goes through a RF switch, where it can be programmed to go to a power sensor, or VNA/VSG. Since RF switch also acts as path from the PWC to measurement instruments, it must also be confirmed that the switch works as intended. During testing, it was detected that when the relay in the switch is set to another state and then switched to an original position, the amplitude changed dramatically. This indicated that one of the modules in the switch was broken, since it did not retain its value.

5.2 Programming

Since the main purpose of the test system is to measure and analyze data, a Python programming language is used. If data is needed to be analyzed or reviewed later, Python makes it easy later on. The PWC communication is done over the Ethernet with the OSP-120 control unit. The Control unit passes the data to the PWC via the optical cable using Rohde & Schwarz's encryption. The control unit uses the VISA standard for communicating with the PC, which is highly used within different RF-measurement instruments.

When the field calibration is originally executed, the saved binary formatted calibration data is stored in the same configuration file where calibration parameters are. Since Verkotan uses in-house software solutions and not the complete R&S's PWC measurement software, the program was needed to be made to search specific frequencies that were calibrated using specific options, and then find the binary data, which is then later sent to the PWC. The function for finding the specific calibration data is shown in FIGURE 11.

```
def find_field_cal(self, freq_target, HP):
    with open(self.file_path, 'rb') as f_in:
        data=f_in.read()
        f_in.close()
    header = '[Field Calibration Results]'
    pos_start=data.index(header.encode())
    data = data[pos_start:]
    pos_end = data.index(b'[Path Loss Calibration Config]')
    data = data[:pos_end]
    lines=data.split(b'\n')
    freqs_lines={}
    for ind in range(2,len(lines)-1):
        program_version,high_power,frequency,time_stamp,maximum_temperature,weights,verdict,PWC_setting=lines[ind].split(b',',7)
        if str(high_power.decode()) == str(HP):
            freqs_lines[float(frequency)]=ind

    freqs=numpy.array(list(freqs_lines.keys()))
    freq_ind = (numpy.abs(freqs - freq_target)).argmin()
    ind=freqs_lines[freqs[freq_ind]]
    cmd = lines[ind].split(b'##4400')[-1]
    return cmd[1:],freqs[freq_ind]
```

FIGURE 11. Function for finding calibration data

When the data has been acquired for the desired settings, it can be sent to the PWC. FIGURE 12 shows the function which handles the command sending.

```

def send_pwc(self, freq, HP, LNA):
    data, self.pwc_freq = self.find_field_cal(freq, HP)
    self.find_path_loss(self.pwc_freq, HP, LNA)
    self.inst.query("SYST:PWC:IDN?")
    self.inst.query("SYSTem:PWC:STATus?")
    a = b'#44000'
    data = a + data
    data = data.decode()
    print('Sending config to PWC' , self.pwc_freq)
    self.inst.write('SYST:PWC:SET ' + str(data))
    self.inst.write('SYST:PWC:LNAM ' + str(LNA))
    errors = self.inst.query("SYST:ERR:ALL?")
    print(errors)
    return self.pwc_freq

```

FIGURE 12. Data is sent to the PWC

5.3 Calibration setup

Calibration is done using a specific calibration antenna, which needs to be perfectly aligned to the center of the PWC. This needs a completely straight support-plate, which is aligned using laser and it is targeted at the center of the PWC. The support plate can be seen in FIGURE 13.

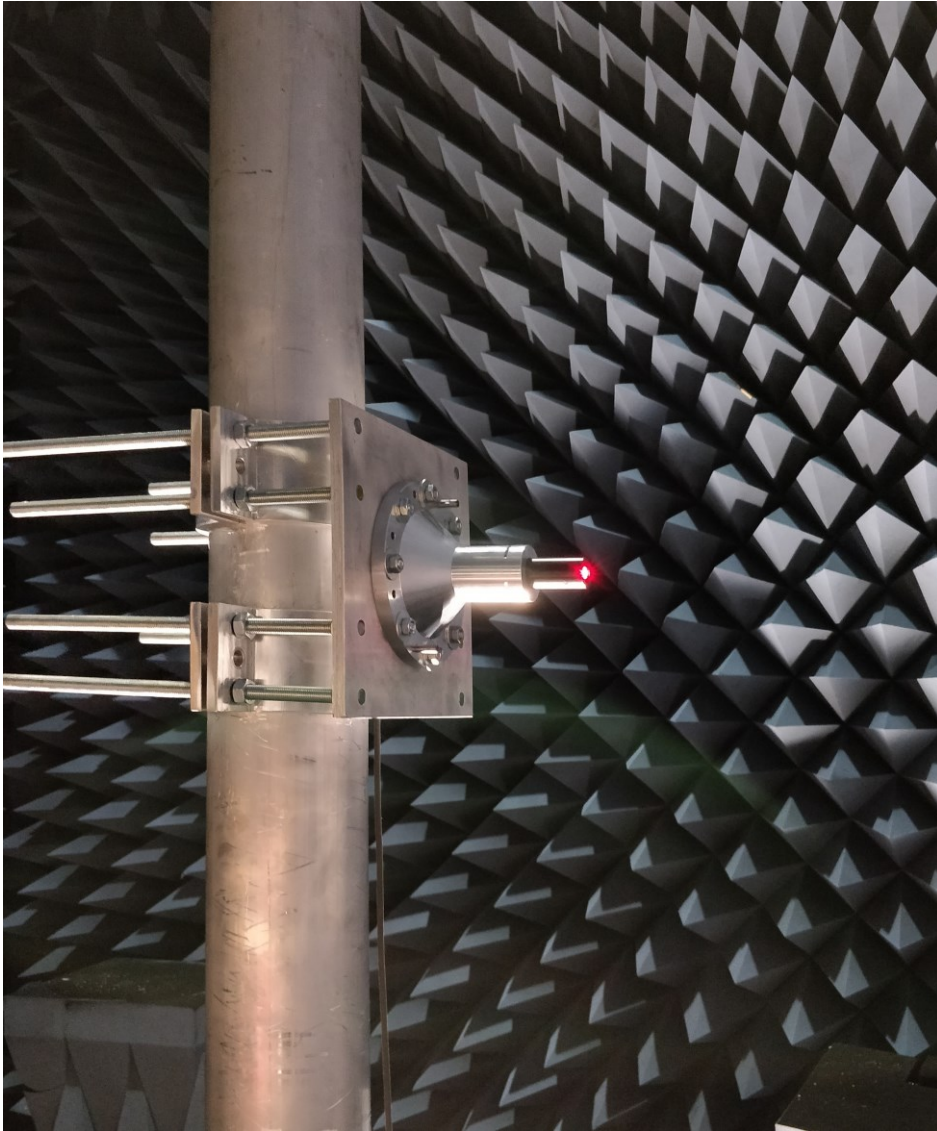

FIGURE 13. Calibration stand

The later performed calibration heavily depends on the fact that the orientation of the calibration antenna is perpendicular to the PWC. Not only the laser needs to be pointing at the center of the PWC, it also needs to maintain the said position when rotating the laser 360 degrees. The target of the laser can be seen in FIGURE 14.

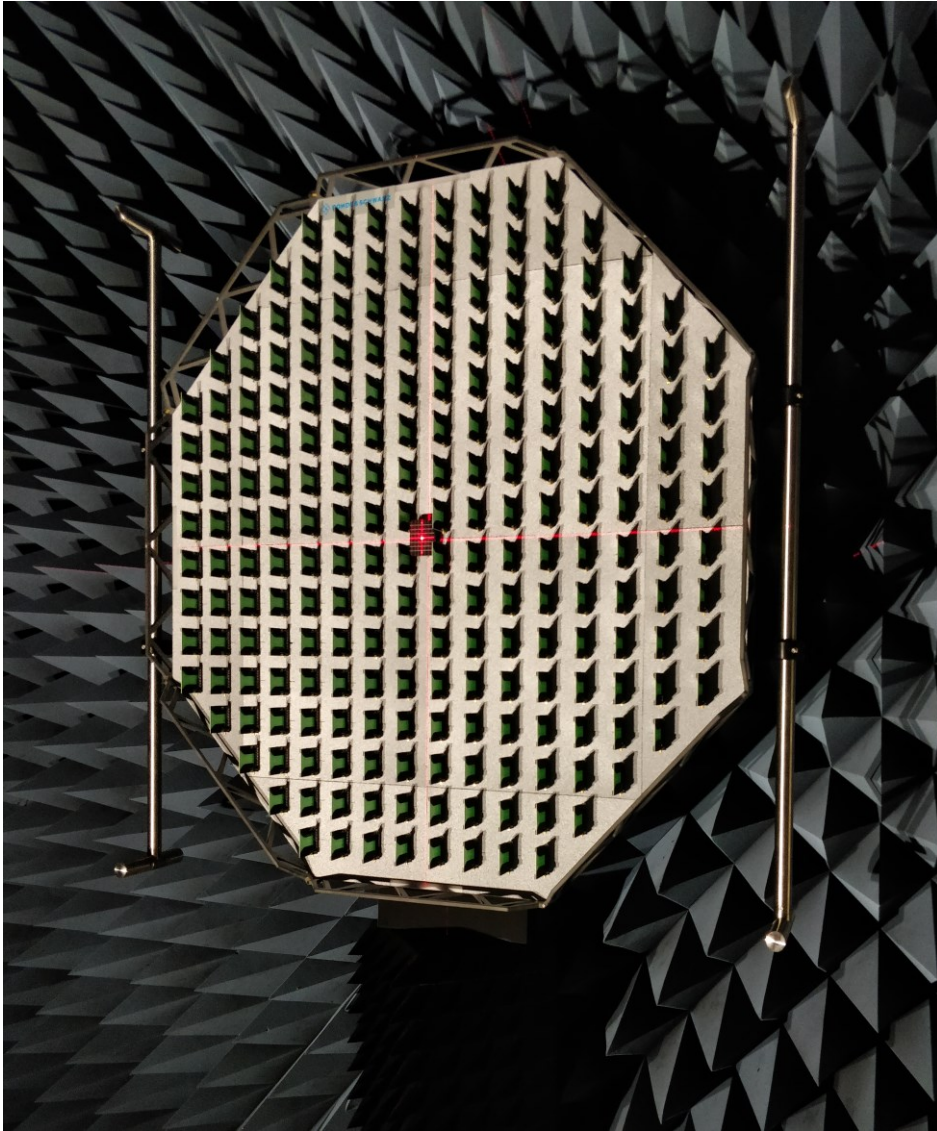

FIGURE 14. PWC with laser target

During the setup, an error margin was found to be within manufacturer's limits, when checking the alignment of the system.

6 PWC CALIBRATION

With the stand now in place, the actual calibration antenna can be mounted.

With this calibration antenna, calibrations can be made to specific frequencies, with the amplifier or attenuators enabled.

6.1 Field Simulation & Calibration

Field simulation is used to calculate the theoretical amplitude weights and phase shifts for each of the antenna elements for a given distance and frequency. These values will later be the target values for the actual field calibration. The Field simulation uses proprietary .mod files, which have this PWC's unique radiation models.

Field calibration tries to adjust antenna weights and phases based on the results of the field simulation, using an iterative optimization method. Since this is measured with the actual calibration antenna, proprietary .cut files are needed to characterize the calibration antennas radiation pattern.

6.2 Path loss calibration

Path loss calibration is done with the calibration antenna, to measure the attenuation over frequency from calibration antenna. The known gain of the calibration antenna is then compensated from the .csv file to the final result.

When conducting the path loss measurement, VNA's port 2 is used as the input source which is connected to the calibration antenna, and VNA's port 1 is used as the output, which connects the RF switch to the PWC.

6.3 Cable calibration

Because of the losses in the cables, calibration is needed. The cables from the calibration antenna are calibrated using VNA and a calibration kit. The Calibration type is one-path two-port calibration, or in some case it is called enhanced response calibration. This calibration is chosen because only two

ports are required when conducting customer measurements and the path between the DUT and the PWC needs to be bidirectional. The calibration setup can be seen in FIGURE 15.

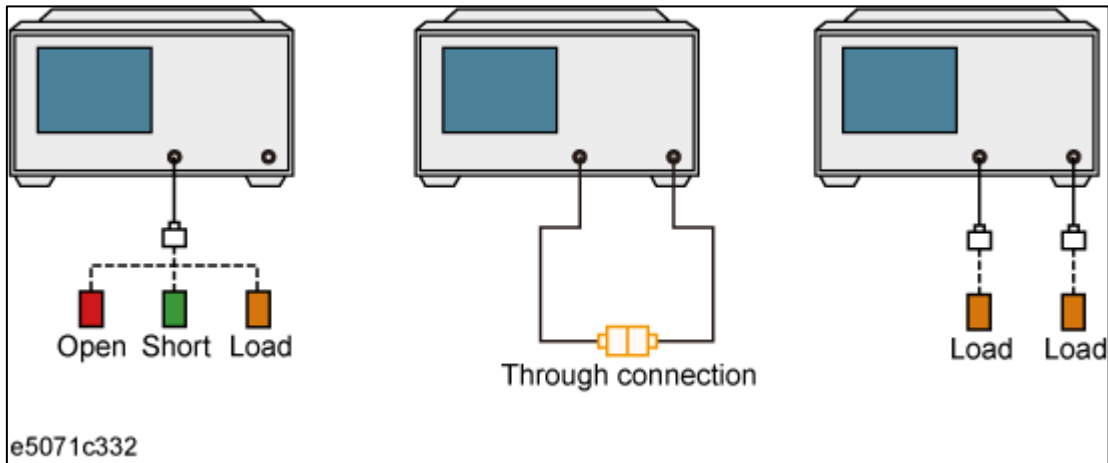

FIGURE 15. One-path two-port calibration. (24)

Calibration is done by inserting the cable to a desired port, and then inserting load, open and short standards to the other end of the cable. And finally connecting the cable straight to the second port.

6.4 Calibration automation

Conducting Field simulations and field calibrations can be time consuming if done by hand. For example, if one were to calibrate the PWC's range 2.3GHz – 3.8GHz with 10MHz steps, it would result 150 different frequencies to be measured. For example, if field simulation takes 1 minute to complete one frequency, it would take 2.5 hours for the simulations alone. After simulation, field calibration is required. For example, if field calibration takes 5 minutes, processing every previously mentioned frequency would take 12.5 hours. Finally, after path loss calibration, the total amount of hours would result in 17.5 hours, if path loss calibration would take one minute. Manually calibrating every single option is a huge waste of resources when it can be automated. When

calibration would come later relevant again, the process would already be automated.

A calibration script was developed, it would take into account span of frequencies, if a high-power mode needs to be activated, and if the user wants to enable LNA. A script utilizes R&S's calibration program, which is run using a subprocess module and after successful calibration backups are made from the resulting file. FIGURE 16 shows part of the program where the subprocess module is used.

```
def calibration(config, mode, HP):
    print('Freqs to be calibrated: ')
    print(freq)
    print('HP = ', HP)

    print('Using config:', config)
    config = config.split('.')[0]

    if HP == '0' or HP == 'both':
        for f in freq:
            params = [mode, config, str(0) , str(f)]
            print('Executing ', params)
            b = s.Popen(params, shell=True, stdout=s.PIPE, stderr=s.STDOUT)
            (out, err) = b.communicate()
            out = out.decode('utf-8')

            if err is None:
                print(out)
            else:
                err = err.decode('utf-8')
                print(out, err)
```

FIGURE 16. Calibration automation function

7 PWC MEASUREMENTS

7.1 Validation

Validation means proving that a laboratory is able to measure antennas inside the specified error limit. Because every antenna has different parameters, some antenna measurements can pick up interference that others do not. This is because some antennas may have a wider main beam, for example. Wider antenna beams are more prone to interference from the walls of the anechoic chamber. Since there are no absolutely perfect anechoic chambers with infinitely long dimensions with materials that do not reflect any radiation in any frequency, there can only be really close approximations of the antenna's characteristics. A reference antenna is used to validate a laboratory, which has properties that are known really accurately. (p.1863 – 1864, 25)

In Verkotan's solution, a reference antenna for the PWC system was provided by a manufacturer, R&S. As seen in FIGURE 17, measured antenna patterns are nearly identical, where orange result is measured in Verkotan's laboratory, and blue one is the typical antenna pattern for this type of a reference antenna.

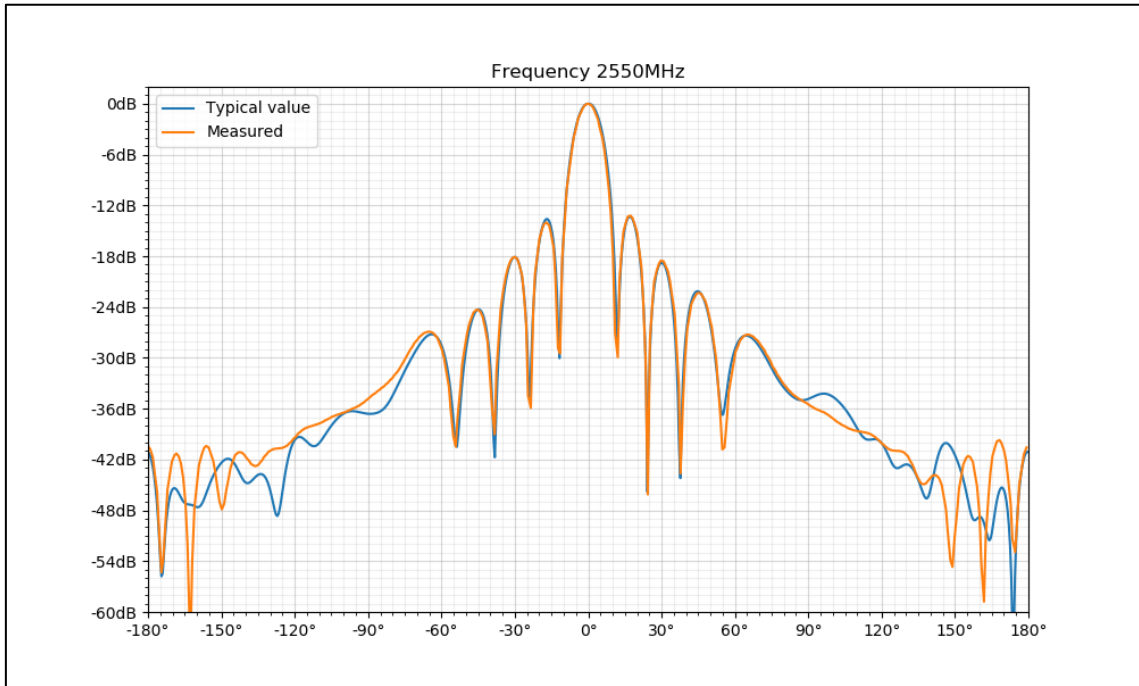

FIGURE 17. Comparison between reference antennas at 2550MHz

7.2 Overview of the system

The PWC test method is going to be accredited according to the 3GPP 38.141-2 standard. For example, it specifies that the minimum requirement for a radiated power measurement is ± 2.2 dB variation from manufacturer's reported main beam's EIRP level. (p. 130, 26) The test system is also capable of making 2D cuts from desired elevation within maximum elevation angle of the system, since the measurement system uses mast in the center of the anechoic chamber, which can be rotated in an azimuthal and an elevational angle, φ (phi) and θ (theta) respectively. The elevation angle of the system is adjustable, and the maximum azimuthal angle is 360 degrees. The coordinate system is depicted in FIGURE 18. Together with the rotating capability of the PWC, 2D cuts can be made with both polarizations with a high accuracy.

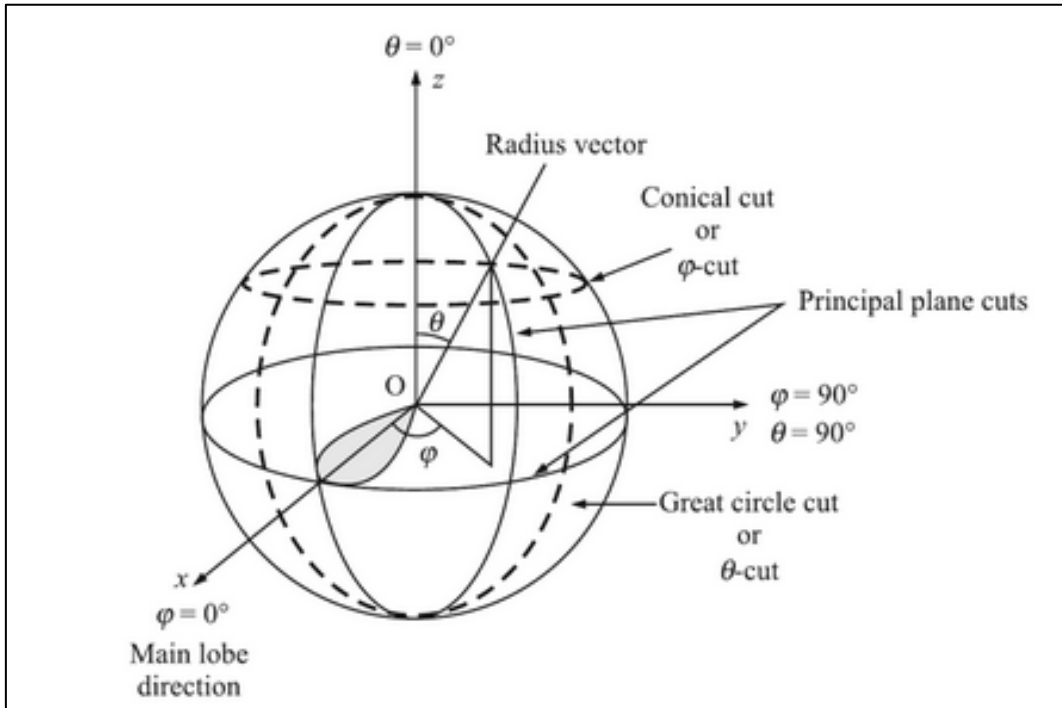

FIGURE 18. Spherical coordinates (p. 479, 27)

7.3 Measurement program

The control PC is used to start measurements and set the desired parameters. For the starting parameters the program needs to know the measured frequency and co-polarization. The PWC angle is then adjusted before the actual measurement, while applying calibration data to the PWC. When a measurement is finished, data is saved with all of the info to recreate the measurement. Resulting data can be seen plotted in the FIGURE 19. From the plotted antenna pattern, an angle can be seen in the X-axis, and a radiated

power in the Y-axis. 2D cuts have a main beam level of -12.7dBm, which can be transformed to watts using:

$$P(W) = 10^{\frac{P(\text{dBm})}{10}} / 1000$$

FORMULA 2

$P(W)$ = Power in watts

$P(\text{dBm})$ = Power in decibel-milliwatts

Which is:

$$10^{\frac{-12.7 * (1 \text{ dBm})}{10}} / 1000 = 0.0000537031796 \dots \approx 0.0537 \text{ mW}$$

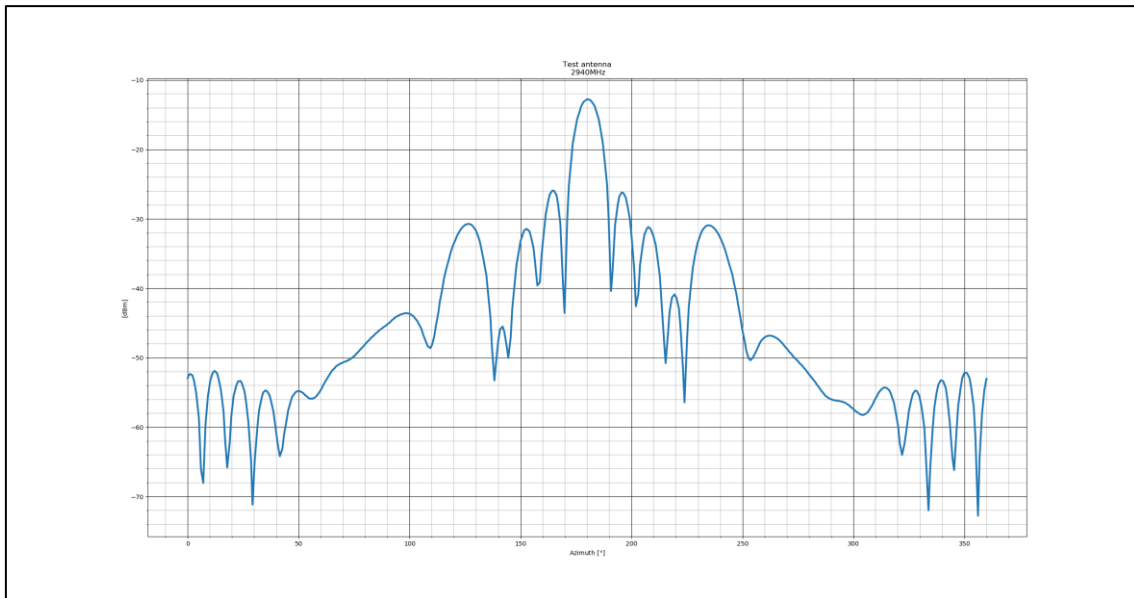

FIGURE 19. Measured reference antenna

8 CONCLUSION

The purpose of this thesis was to learn about the plane wave converter solution provided by Rohde & Schwarz, which is used in base station measurements, and then develop an in-house software for calibrating, operating and measuring with the PWC. The test system used other measurement instruments in addition to Rohde & Schwarz's PWC test system to further increase the measurement capability and reliability of the test system.

A lot has been learned about the properties of the new test system, along with the knowledge regarding the common problems when implementing a system like this, and how to avoid them. Program developing skills have improved along with the knowledge of measuring high frequency base stations and developing antenna test system.

The largest challenge was developing a system that seamlessly uses all of the peripherals and devices, while maintaining accuracy in the measurements and keeping the measurement time as low as possible. As seen from the previous section 7, the reference antenna produces almost an identical and smooth antenna pattern when comparing to manufacturer's values, which speaks for the accuracy of the system. The program can be later developed further to support new types of requirements. The system has been put into operation at Verkotan, to satisfy a new customer's needs.

REFERENCES

1. Tutorialspoint. 2020. Antenna Theory - Beam Width
Date of retrieval 23.01.2020.
https://www.tutorialspoint.com/antenna_theory/antenna_theory_beam_width.htm
2. Electronics Notes, 2020. Antenna Polarization.
Date of retrieval 10.01.2020.
<https://www.electronics-notes.com/articles/antennas-propagation/antenna-theory/polarisation-polarization.php>
3. Arazi, S. 2020. Antenna Fundamentals.
Date of retrieval 10.01.2020.
<https://www.mtiwe.com/?CategoryID=353&ArticleID=163>
4. Hardesty, G. 2019. Antenna Polarization: Vertical, Linear: Key Factor in Selection of an Antenna.
Date of retrieval 10.01.2020.
<https://www.data-alliance.net/blog/antenna-polarization-vertical-linear/>
5. Norman, T. 2014. Radio Frequency Systems.
Date of retrieval 07.01.2020.
<https://www.sciencedirect.com/topics/engineering/antenna-gain>
6. Taoglas. 2020. Total Isotropic Sensitivity: A Primer
Date of retrieval 07.01.2020.
<https://www.taoglas.com/wp-content/uploads/pdf/Total-Isotropic-Sensitivity-ED-16-003.A.pdf>
7. Bevelacqua, P. 2020. Effective Isotropic Sensitivity (EIS).
Date of retrieval 07.01.2020.
<http://www.antenna-theory.com/definitions/eis.php>
8. Foegelle, M. 2002. Antenna Pattern Measurement: Concepts and Techniques. ETS-LINDGREN.
Date of retrieval 07.01.2020.
<http://www.ets-lindgren.com/sites/etsauthor/WhitePapers/APM.pdf>

9. Balanis, C 2015. Antenna Theory. Wiley.
10. M2 Inc. 2017. Antenna Gain: dBi vs. dBd.
Date of retrieval 23.01.2020.
<https://www.m2inc.com/blog/dbi-vs-dbd/>
11. Aalto University. 2020. LTE Radio Link Budget.
Date of retrieval 14.11.2019.
https://mycourses.aalto.fi/pluginfile.php/554543/mod_folder/content/0/LTE%20Radio%20Link%20Budget.pdf?forcedownload=1
12. Petted, B. 2019. Antenna Design Gain and Range.
Date of retrieval 14.11.2019.
<https://www.lairdconnect.com/resources/white-papers/antenna-design-gain-and-range>
13. Porokhnyuk, A. 2018. How to interpolate E & H field principal cuts to make 3D antenna radiation pattern in MATLAB.
Date of retrieval 14.11.2019.
https://www.researchgate.net/post/How_to_interpolate_E_H_field_principal_cuts_to_make_3D_antenna_radiation_pattern_in_MATLAB
14. Hansen, J.E. 1988. Spherical Near-Field Antenna Measurements. The Institution of Engineering and Technology, London, United Kingdom.
15. Verkotan. 2020. Antenna and OTA Test Laboratory.
Date of retrieval 23.01.2020.
<https://verkotan.com/antenna-and-ota-test-laboratory/>
16. Wang, Hui – Miao, Jungang – Jiang, Jingshan – Wang, Ruzheng 2012, Plane-wave synthesis for compact antenna test range by feed scanning.
Date of retrieval 14.01.2020.
<https://pdfs.semanticscholar.org/51f5/3a965d9a7850b6dddb9254c9bd9c6adb0f1b.pdf>
17. E. P. Schoessow. 1980. Plane wave synthesis: a new approach to the problem of antenna near-field/far-field transformation
Date of retrieval 13.01.2020.
<http://theses.whiterose.ac.uk/14617/1/281082.pdf>

18. Burchell, B. 2020. Diffraction of Light.
Date of retrieval 15.01.2020.
<http://www.alternativephysics.org/book/Diffraction.htm>
19. Philippakis, M. 1996. Compact antenna range performance evaluation using simulated pattern measurements. IET.
Date of retrieval 14.01.2020.
<https://ieeexplore.ieee.org/document/503110>
20. Burchell, B. 2018. Diffraction of Light.
Date of retrieval 15.01.2020.
<http://www.alternativephysics.org/book/Diffraction.htm>
21. Wolff, C. 2020. Tapered Slot Antenna (Vivaldi- Antenna).
Date of retrieval 15.01.2020.
<https://www.radartutorial.eu/06.antennas/Tapered%20Slot%20Antenna.e.n.html>
22. Wolff, C. 2020. Tapered Slot Antenna (Vivaldi- Antenna).
Date of retrieval 15.01.2020.
<https://www.radartutorial.eu/06.antennas/Tapered%20Slot%20Antenna.e.n.html>
23. Rohde & Schwarz. 2020. R&S@PWC200 Plane Wave Converter.
Date of retrieval 18.01.2020.
https://www.rohde-schwarz.com/pt/product/pwc200-productstartpage_63493-533696.html
24. Keysight. 2020. E5071C ENA Series Network Analyzer.
Date of retrieval 18.01.2020.
<http://ena.support.keysight.com/e5071c/manuals/webhelp/eng/>
25. Pivnenko, S – Pallesen, J – Breinbjerg, O – Castañer, M – Almena, P – Portas, C – Sanmartín, J – Romeu, J – Blanch, S – González-Arbesú, J – Sabatier, C – Calderone, A – Portier, G – Eriksson, H – Zackrisson, J – . 2009. Comparison of Antenna Measurement Facilities With the DTU-ESA 12 GHz Validation Standard Antenna Within the EU Antenna Centre of Excellence. IEEE.

Date of retrieval 18.01.2020.

<https://ieeexplore.ieee.org/document/4907125>

26. 3GPP. 2020. NR; Base Station (BS) radio transmission and reception

Date of retrieval 18.01.2020.

https://www.3gpp.org/ftp/Specs/archive/38_series/38.141-2/38141-2-g20.zip

27. Kumar, S – Shukla, S. 2016. Wave propagation and antenna engineering. Delhi: PHI Learning Private Limited.