

LITES

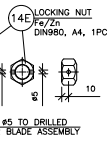

NOTE!  
WELDING CLASS: C EN 5817.  
T=GAS TIGHT WELD.  
ALL CORNERS RADIUS Rmin=2mm.

Customer		AKC	Basic Material Name		Basic Material Standard	Net weight (kg)
Pos. no.	Customer Drawing No	Description Line 1		Designed	Date	
Product Type	Product Code	Description Line 2		Drawn	Date	
Size A2	Scale 1:5	Description Line 1 (EN) RODDER ADAPTER, MANUFACTURING DRAWING		Checked	Date	
Division	ProdHome ACAD	Description Line 2 (EN)		Approved	Date	
Replacement for drawing		Rev. Replaced by drawing	Rev. Copy from drawing	Rev. Sort		
SAP Mat. no./Variant		Ref. dwg	Old Drawing No	Rev. M-File		
SAP Main WBS Element			Drawing no.	Rev. Sheet		

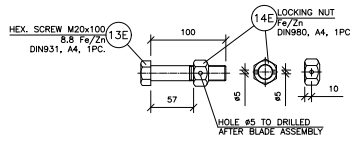
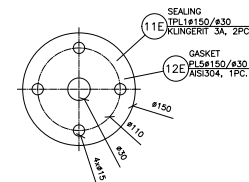
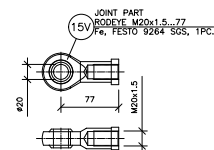
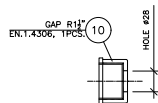
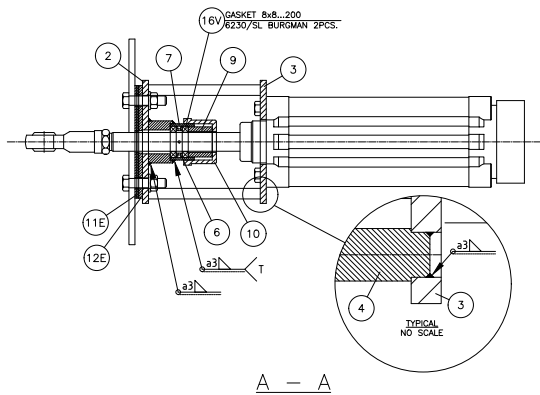
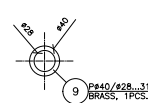
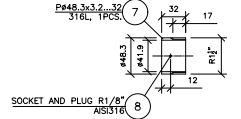
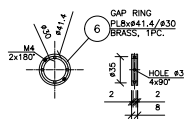
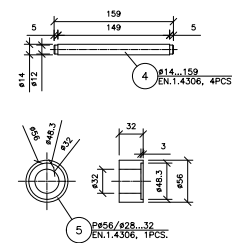
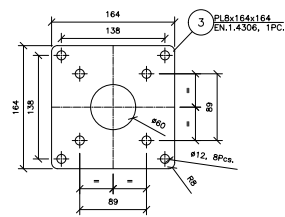
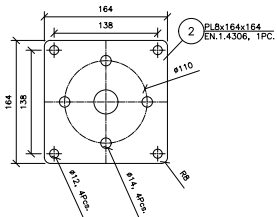
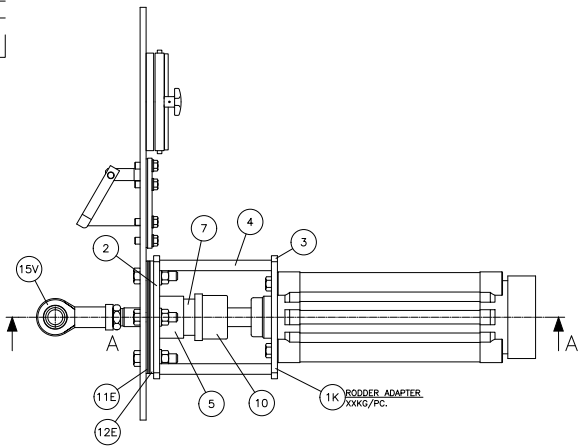

This document constitutes confidential and proprietary information of ANDRITZ. It is intended for the use of the recipient only. It is not to be distributed, copied, or otherwise used without the express understanding and agreement that it will be held confidential and that its use is limited to the purpose for which it was provided. Any use for other than the intended purpose without the express agreement of ANDRITZ is prohibited.

Printed: 27 Feb 2018