



Mechanical design of

# **Advanced self-aligning mounting system**

Filip Långbacka

Bachelor's thesis

Mechanical and Production Engineering

Vaasa 2012



# BACHELOR'S THESIS

Author: Filip Långbacka  
Degree programme: Mechanical and Production Engineering, Vaasa  
Specialization: Mechanical Construction Systems  
Supervisors: Kaj Rintanen & Tomas Södö

Title: *Mechanical design of advanced self-aligning mounting system*

---

Date: 20 April 2012

Number of pages: 25

Appendices: 1

---

## **Abstract**

This thesis work has been conducted in cooperation with Wärtsilä Ship Power. The purpose with this study was to design a mounting system that uses air springs as engine mounts for the Wärtsilä engine 12V46f. This project was started in order to improve the degree of insulation and to eliminate the frequent engine re-alignment that is needed when soft mounts are used. The main focus of this study has been placed on the mechanical construction of the mounting system.

This study is based on a former thesis that is mostly focused on the forces that the air springs are exposed to. The theoretical part in my thesis describes the demands made by the classification society and the basics of an air spring. The results are presented and motivated at the end of the thesis.

---

Language: English

Key words: air spring, mounting system

---

Filed at Theseus.fi

# EXAMENSARBETE

Författare: Filip Långbacka  
Utbildningsprogram och ort: Maskin- och produktionsteknik, Vasa  
Inriktningsalternativ: Maskinkonstruktion  
Handledare: Kaj Rintanen & Tomas Södö

Titel: *Konstruktion av avancerad självlinjerande uppställning*

---

Datum: 20.4.2012

Sidantal: 25

Bilagor: 1

---

## Abstrakt

Detta examensarbete har utförts i samarbete med Wärtsilä Ship Power. Målet med denna studie var att konstruera en motoruppställning med luftbälgar som flexibla element för Wärtsilä motorn 12V46f. Detta görs för att förbättra isoleringen av vibrationer och eliminera den återkommande linjeringen av motorn som krävs när mjuka element används. Tyngpunkten i denna studie ligger på konstruktionen av motoruppställningen.

Denna avhandling baserar sig på en tidigare studie som fokuserar på de krafter som verkar på luftbälgarna. Teoridelen i denna avhandling presenterar kraven som ställs av klassificeringssällskapet samt luftbälgars funktion och uppbyggnad. Resultaten presenteras och motiveras i slutet av avhandlingen.

---

Språk: engelska

Nyckelord: luftbälg, motoruppställning

---

Examensarbetet förvaras i webbiblioteket Theseus.fi

# OPINNÄYTETYÖ

Tekijä: Filip Långbacka  
Koulutusohjelma ja paikkakunta: Kone- ja tuotantotekniikka, Vaasa  
Suuntautumisvaihtoehto: Koneensuunnittelu  
Ohjaajat: Kaj Rintanen & Tomas Södö

Nimike: *Kehittynyt koneen linjaus ja kiinnitys suunnittelu*

---

Päivämäärä: 20.4.2012

Sivumäärä: 25

Litteet: 1

---

## Tiivistelmä

Olen tehnyt opinnäytetyöni yhteistyössä Wärtsilä Ship Powerin kanssa. Tämän työn tarkoitus on ollut suunnitella moottorin kiinnitysjärjestelmä käyttäen ilmatyynyjä kiinnityselementteinä Wärtsilän 12V46f moottorille. Tarkoituksena on parantaa moottorin eristystä ja välttää moottorin toistuvia linjauksia, jota pehmeät elementit vaativat.

Eniten painoa tässä tutkimuksessa on laitettu kiinnitysjärjestelmän suunnitteluun. Tämä tutkimus perustuu aikaisempaan opinnäytetyöhön, jossa enimmäkseen on keskitytty niihin voimiin joille ilmatyynyt altistuvat. Teoreettinen osa tässä työssä esittelee vaatimukset luokituslaitoksen ja ilmatyynyjen perustiedot. Tulokset esitellään ja motivoidaan tutkimuksen lopussa.

---

Kieli: englanti

Avainsanat: ilmatyyny, moottorin kiinnitys

---

Opinnäytetyö arkistoidaan nettikirjastossa Theseus.fi

## Table of contents

Abstract

Abstrakt

Tiivistelmä

1	Introduction.....	1
1.1	Background .....	2
1.2	Goal.....	2
1.3	Problems.....	4
1.4	Limitations .....	4
1.5	Outline.....	4
2	Earlier research .....	5
2.1	Results of earlier research .....	5
3	Theoretical background .....	8
3.1	Air spring.....	8
3.2	Demands made by classification society.....	9
4	Results .....	10
4.1	Methods.....	10
4.2	Mechanical construction of flexible mounting system .....	10
4.2.1	Upper fixing rail .....	11
4.2.2	Air Springs .....	12
4.2.3	Lower fixing rail .....	13
4.2.4	Buffers.....	14
4.2.5	Transport brackets .....	18
4.2.6	Valves .....	22
4.2.7	Resin chocks.....	22
4.2.8	Installation procedure.....	23
5	Discussion and conclusion.....	24
6	List of sources .....	25

## Preface

I want to thank Wärtsilä Ship Power for giving me the opportunity to make this thesis and also for the friendly welcoming to the company. Especially I want to thank Mr. Tomas Södö who has been my supervisor at Wärtsilä and the person who assigned me this project.

I also want to thank both the Mechanical and Vibration team at Wärtsilä for all the guidance that they have given me throughout this project. At Novia University of Applied Sciences I want to thank my supervisor Mr. Kaj Rintanen.

*Vaasa, 20 April 2012*

*Filip Långbacka*

# 1 Introduction

Vibration is in its simplest form an oscillation around an equilibrium point. The oscillations can be periodic such as the motion of a pendulum, or random such as the movement of a tire on a stony road. Vibrations are in most cases undesirable but in some cases they are necessary in order to fulfill the function of a device. An example where vibrations are necessary is in a loudspeaker, where the vibration is the motion of the cone, which creates sound or pressure waves. As said before vibrations are in most cases undesirable and in mechanical structures they cause noise and material fatigue which can result in breakdown. (Introduction to mechanical vibrations)

Almost every engine type causes vibrations when it is running. Vibrations are always caused by an excitation force, and in an internal combustion engine the excitation forces occur from e.g. imbalance, oscillating mass, gas forces and different mechanisms. This means that it is impossible to avoid vibrations in an internal combustion engine. Thus, in order to reduce vibrations and noise transfer to the rest of the construction, engines can be resiliently mounted on rubber elements.

The degree of insulation depends on what kinds of rubber elements are used, but generally speaking, the softer the rubber elements are, the better the insulation is. The disadvantage of using soft rubber elements is that they will result in greater movement and when it concerns engines with small movement allowances this is not acceptable. Another disadvantage with soft rubber elements is that they have a higher creep rate, which will result in frequent re-alignment of the engine if the engine has a strict alignment tolerance to other machine parts such as a generator or a gearbox.

One type of vibration insulators are air springs. Air springs are good insulators thanks to their low natural frequencies and thanks to the fact that the rubber creep rate doesn't need attention, because an automatic self-leveling system can be combined with air bellows. Inside an air bellow there is an air volume that can be altered by increasing or decreasing the air pressure, and by doing this the desired height can be achieved at all times.

## **1.1 Background**

Wärtsilä Ship Power, which I have done my thesis work for, is a Finnish corporation that provides customers with lifecycle solutions within the marine sector. They are best known for their engines but they also provide customers with propulsion systems, seals and bearings, gears, and automation.

This thesis work is part of a new flexible mounting system for ship engines. The main focus of this study has been placed on the mechanical construction of the mounting system and based on an earlier study by Mr. Anders Wasberg made in 2011. The work by Wasberg is mainly devoted to solving the forces that the air springs are exposed to. I was assigned this project in 2011 after having worked a summer at the Department of Mechanical Engineering at Wärtsilä. They started this project in order to improve the degree of insulation and to eliminate the frequent engine re-alignment that the conventional system requires. To improve the insulation degree of vibration and noise transfer, softer mounting elements are often used. At the same time natural frequencies shift further away from excitation frequencies. Soft mounting systems are therefore needed for vessels with strict vibration and noise requirements.

The disadvantages of using softer mounting elements are that the rubber creep rate is much higher and repeatedly re-alignment of the engine is needed. In order to avoid the frequent re-alignments this mounting system is designed with air springs with an automatic height adjustment instead of regular rubber elements. Wärtsilä will continue developing this project after my thesis work is finalized.

## **1.2 Goal**

The purpose of this study is to design a 3D model of an engine mounting system using air springs for the Wärtsilä engine 12V46F. Figure 1 and table 1 below describe the main dimensions and data of the engine. The 3D model will include a total solution which will be mounted between the engine and the ship foundation. A cost calculation will also be made in order to compare the total cost of a mounting system that uses air springs instead of a regular flexible mounting system.



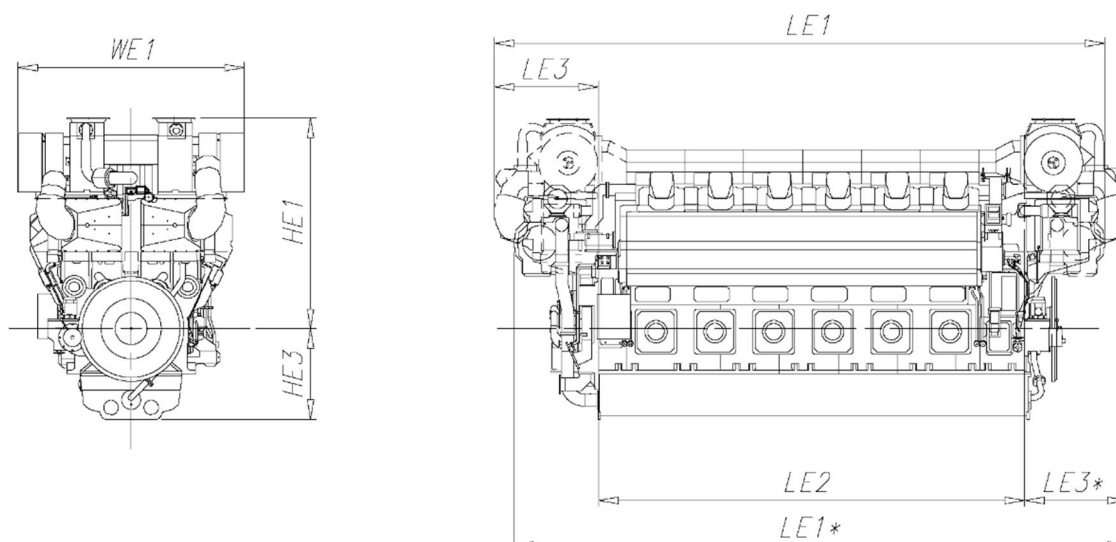

Figure 1. V-engine

Table 1. Dimensions and weight

Engine	LE1*	LE1	LE2	LE3*	LE3	HE1	HE3	WE1	WE3	Weight (ton)
12V46F	10945	10284	7600	1830	1952	3765*/ 3770	1620	4040*/ 4026	1820	177

\*Turbo charger at flywheel end

All dimensions are in mm. The weight is dry weight of a rigidly mounted engine without flywheel.

### Main data and output

- 4-stroke turbocharged and intercooled diesel engine with direct fuel injection.
- Cylinder bore 460 mm
- Stroke 580 mm
- Speed 600 rpm
- Max. Continuous output 14400 kW (IMO Tier 2)

(Wärtsilä 46F product guide 2011)

### **1.3 Problems**

Today Wärtsilä uses different rubber elements in their flexible mounting systems for ship engine arrangements. The characteristics for these rubber elements differ from each other, but they all have one common problem, which is the creep rate of rubber. This means that the engine will move from its position where it has been initially aligned. Due to this a repetitive re-alignment will be needed in the future. Today when they re-align the engine they use shims to get the correct alignment, which is a time-consuming and costly operation. By using air springs instead of regular rubber mounts the engine height can be adjusted automatically with the help of height sensors to the right position at all times as it will be active during engine operation.

### **1.4 Limitations**

The main focus of this study is on the mechanical construction of the flexible mounting system. The control system for the air springs is not included in this study. This study has been limited to one engine type, i.e. the 12V46F. The upper fixing rails have been designed so that they can be fitted to this engine type irrespective of the amount of cylinders used.

### **1.5 Outline**

In the first chapter of this thesis an introduction to the subject is given, followed by the background and the definition of the goal. A problem discussion and some limitations are presented at the end of the first chapter. In the second chapter earlier research and its results are presented. The third chapter consists of a theoretical background divided into two different parts: air springs and demands made by classification society. In the fourth chapter the results are presented. The results are divided into subchapters, in which they are presented and motivated part by part. The fifth chapter consists of a concluding discussion.

## 2 Earlier research

An earlier study for this project has been made by Mr. Anders Wasberg in cooperation with Wärtsilä Ship Power. His study was a Bachelor's thesis done during winter/spring 2011 at Novia University of Applied Sciences in Vaasa. It is a pre-study for a mounting system using air springs in a V configuration. His study was made for a different engine, but it has given me a good holistic view of what Wärtsilä use today in their flexible mounting systems.

He started by presenting different mounts and mounting arrangements that Wärtsilä use today. In his research he found that sandwich, conical and steel spring mounts are mostly used today. The different mounting arrangements that he wrote about were v-mounting, vertical mounting and double elastic mounting. He also wrote a section about creep rate. In the section about creep rate he wrote that the deflection of the mounts gets smaller by time when they are applied to loads. This means that it is hard to prevent how much the rubber mounts will deflect, because it varies by time and the applied load. He also described vibrations and how they occur in an internal combustion engine. The major result of his thesis work was a force calculation program made in Excel. The force calculations will be explained more in chapter 2.1, I have used the same formulas in Excel for my calculations of the forces that are applied to the air springs.

### 2.1 Results of earlier research

The following calculations are based on Mr. Wasberg's thesis. The result of this earlier research is an Excel calculation program, which gives you the forces that the air springs are exposed to. This Excel calculation allows you to adjust the distance between the point where the air springs' hypothetical centerlines cross each other and the center of gravity, as well as variable roll and trim angles. The facts that are needed for the calculation are as follows:

- Engine weight
- Torque caused by the engine
- Angle of roll and trim
- All distances on the engine and mounting arrangement

The first calculation that Mr. Wasberg made was with  $0^\circ$  roll and  $0^\circ$  trim. This case occurs when the engine is in a horizontal position. To determine the forces, the following schematic picture (figure 2) was made.

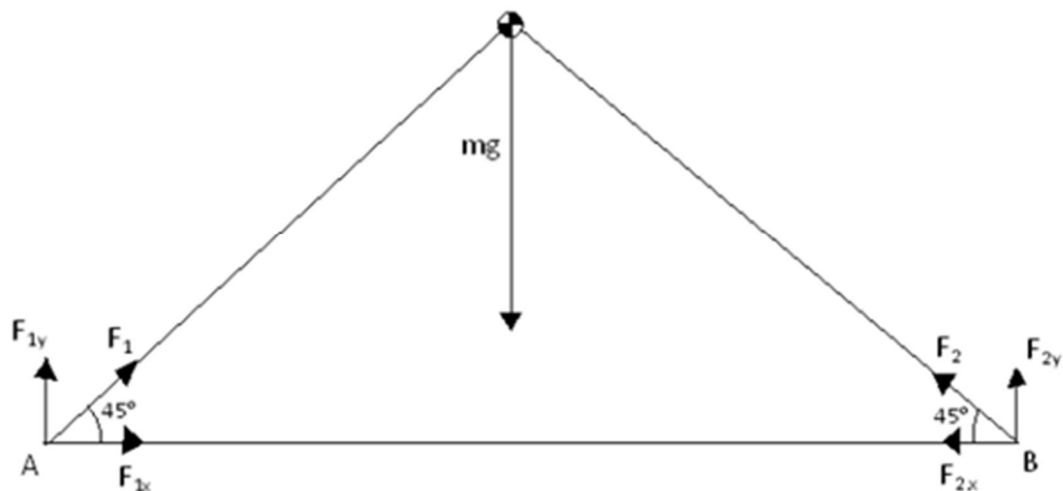

Figure 2. The forces with engine in horizontal plane.

Vertical:

$$mg - F_{1y} - F_{2y} = 0$$

Horizontal:

No horizontal forces will occur

The next calculation he did was to determine the force vectors for the torque caused by the engine. These force vectors are added to and subtracted from the y-component force vectors caused by the engine weight. Figure 3 shows a schematic picture of the torque.

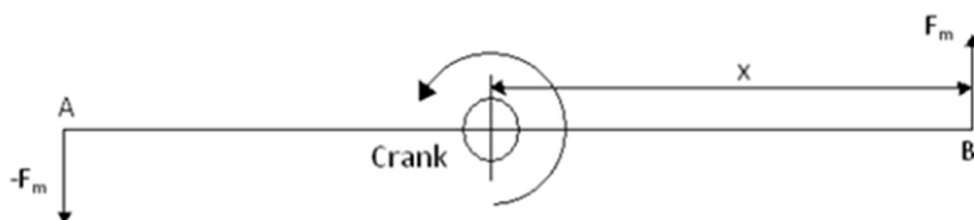

Figure 3. The torque caused by the engine.

$$M_v = 2 * F_m * x$$

$$F_m = \frac{M_v * 0,5}{x}$$

After this he calculated the force that occurs with both roll and trim together. In order to do this he projected a new force from the center of gravity ( $mg$ ) due to trim. After this the calculation of roll can be made with the projected  $m'g$ . Figure 4 shows a schematic picture of the new  $m'g$  with trim.

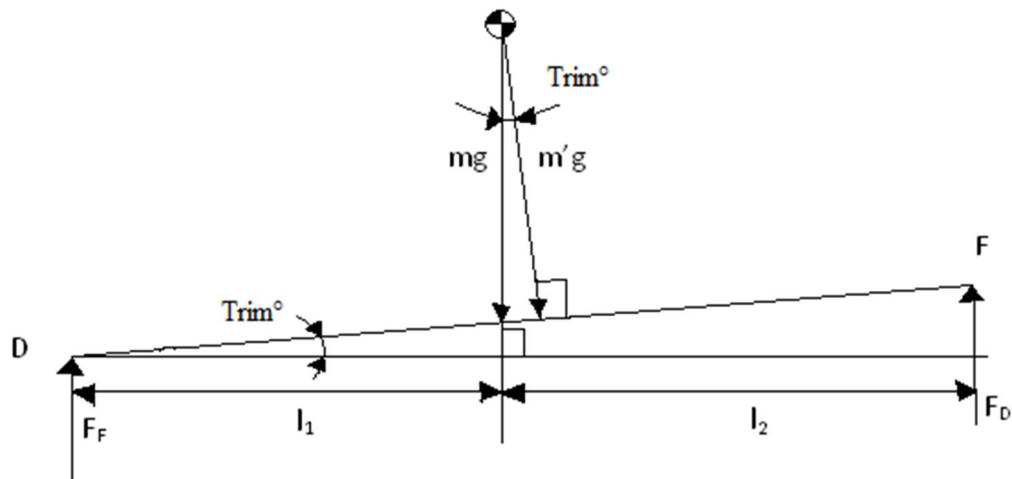

Figure 4. The projected  $m'g$  due to the trim of the ship.

$$F_F * l_1 = F_D * l_2$$

$$F_F = F_D * \frac{l_2}{l_1}$$

With all these formulas in the Excel calculation it is very easy to get the worst case calculated. I have used this Excel calculation for my study in order to determine the forces that are exposed to the air springs. The size of the forces is mentioned in chapter 4.2.2, Air springs.

### 3 Theoretical background

In this chapter I will explain the function of air bellows and how they are made. I will also clarify the demands for the flexible mounting system, made by the classification society.

#### 3.1 Air spring

An air spring or an air bellow is a single acting pneumatic actuator made of reinforced elastomer material. Each end of the bellow is attached to a cover containing mounting holes and air inlet ports. In most cases the covers, called bead rings, are made of steel and they are either crimped onto the bellow or made as removable bead rings. With the removable bead rings you get wider options for air inlet ports and etc. The bellows exist in single-, double-, triple convolutions and rolling sleeve type. The major differences between these are the output of stroke; single convolution bellow has the lowest stroke when the triple convolution and the rolling sleeve type have the highest stroke. In general it can also be said that the higher the bellow stroke is, the less force can be applied to the bellow. (Firestone 2007)

The fundamental concept of the air spring is a mass of air under pressure in a vessel, arranged so that the pressure exerts a force. The amount of force developed by the air spring is dependent on the internal pressure and the effective area of the air bellow. The effective area changes when the operating height changes. Therefore the developed force by the air spring will decrease when the height increases. The rubber bellows itself does not provide force or support load.

The standard two-ply bellow from Firestone consists of four layers. In figure 5 the different layers are presented. The inner layer and the outer cover are of calendered rubber. The first and second plies are of fabric reinforced rubber and the second ply has the cords at a specific bias angle to the first ply. Most of the Firestones air bellows are also available in high strength construction for higher pressures. In this case there are four plies of fabric-reinforced rubber, with an inner liner and outer cover. (Firestone 2005)

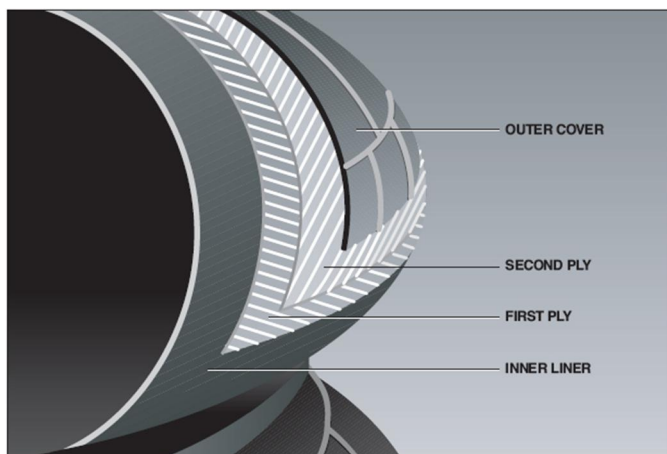

Figure 5. Layers in an air spring

Air springs can provide the highest degree of insulation of any type vibration isolators and they can isolate loads from 0,45 kN to 575 kN per mounting point. The system's natural frequencies can be as low as 1 Hertz. In addition to the auxiliary reservoir the system's natural frequencies can even be lowered. With an auxiliary reservoir connected externally to the air bellow it will get a bigger internal volume, which means that a lower natural frequency is achieved for the system. In order for the reservoir to work properly, there must be a free flow of air between the air bellow and the reservoir. The air bellow's natural frequencies do not change significantly when the load changes. When using air bellows as vibration isolators the suppliers suggest a specific design height for the air bellow. At this height the bellow will have its maximum lateral rate or stability. (Firestone 2007)

### 3.2 Demands made by classification society

According to the DNV's rules for the classification of ships regarding engines with resilient mounting, the elastic mounts shall be able to support the mass of the engine, the reaction forces due to engine torque, the maximum environmental conditions as list and trim, and the dynamic loads without exceeding the approved specifications. This means that the elastic mounts shall handle at least the mass of an engine with 18 degrees roll and 6 degrees trim at the same time, plus the forces due to engine torque. Besides this the rules declare that there are to be stoppers preventing the excessive movements. This means that the engine must remain in its bed even if the ship should be upside down. (DNV 2011, p. 38)

## **4 Results**

In the following chapter the results will be presented in two sections; methods and mechanical construction. The methods used are mostly discussions and studies of previous mounting arrangements. The different parts of the mechanical construction are presented and motivated in subheadings. A picture of the complete mounting system will be presented in subchapter 4.2, figure 6.

### **4.1 Methods**

My results are outcomes from discussions with engineers at Wärtsilä and studies of mounting systems that Wärtsilä uses today. Engineers at Wärtsilä have a good knowledge of the different flexible mounting arrangements that are used today and they have provided ideas for this project. I have looked at Wärtsilä's current designs of mounting systems and compared these and then I have developed new parts and discussed them with engineers at Wärtsilä in order to make the new design with air springs.

The 3D models of the different parts have been made in NX Unigrafix, except for the engine block and the standard parts such as bolts, nuts and washers which have been designed earlier in I-deas. The design started with simplifying the engine block of a W12V46f engine in I-deas and after that it was exported to NX. I have used a top-down modeling method, which means that I started with the part closest to the engine and worked myself down to the ship's tank top. When the concept design of the mounting system had been done, I made strength calculations on the different parts in order to ensure a durable construction. After these calculations I modified the parts that were over or under dimensioned and then I finished the construction by making all the details.

### **4.2 Mechanical construction of flexible mounting system**

This section contains the different parts of the flexible mounting system that I have designed. Moreover, the reasons for why the mounting system is chosen to be in a V configuration are presented.

The V mounting configuration has been selected because of the great advantages it has against roll and trim that occurs in ships. It will also obstruct the force that is produced by the engine torque and because of these characteristics the v-mounts will prevent the engine



from rolling. Another aspect is that if the stiffness centre is near the center of the flexible coupling, the coupling will only be exposed to very small movements. (Wasberg 2011)

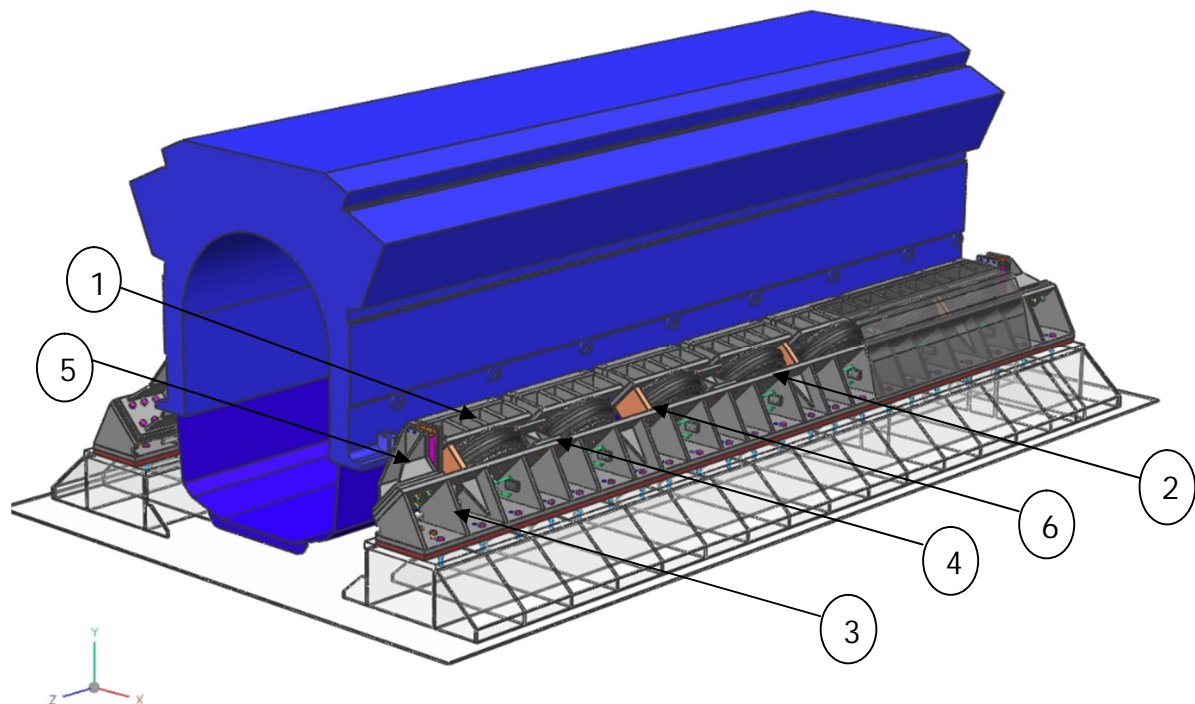

Figure 6. Complete assembly of the mounting system with air springs.

Location of different parts

1. Upper fixing rail
2. Air spring
3. Lower fixing rail
4. Height/lateral buffer
5. Longitudinal buffer
6. Transport brackets

#### 4.2.1 Upper fixing rail

The upper fixing rails (No 1 in figure 6), which are bolted together with the engine, have been designed as separate brackets. The advantages with separate brackets are that they can be mounted on all W46f engines regardless of the cylinder configuration. The engine length differs according to the amount of cylinders. Another advantage with separate brackets is that they are less expensive to manufacture.

In order to ensure that no additional tension occurs in the bracket when fastening it to the engine, the upper flat bar (No 1 in figure 7) is bolted together with the bracket instead of being welded. This will also facilitate the assembly of the brackets to the engine block. The

holes for the bolts are to be with clearance, so that the flat bar can be adjusted to the engine feet.

No strength calculations have been done on the fixing rail, because similar designs have been made earlier by Wärtsilä.

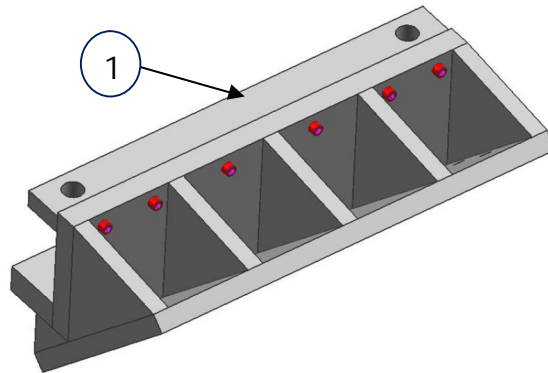

*Figure 7. Picture of upper fixing rail*

#### **4.2.2 Air Springs**

The air springs that I have used in this design are from Contitech and the model is FS 2870-16 RS, which is a single convolution type with removable bead rings. The bead rings for this bellow are not standard parts from Contitech, but they are custom made. In appendix 1 you will find an information leaflet of the air bellow FS 2870-16 RS. A picture of the air spring with bead rings is shown in figure 8.

In this design I have placed seven air springs of this model on each side of the engine in a 45 degree angle. This standard air spring allows a maximal internal pressure of 8 bar and at this pressure it can handle a load of 224,9 kN when the spring has its recommended design height of 150 mm. The force that is applied to one air spring when the engine is in a horizontal position is 196 kN. This force is only calculated with engine weight and engine torque. Thus that the air springs will manage to handle the load at nearly 6,8 bar.

With the maximal trim and roll plus the engine torque added to the engine weight, all according to DNV's rules, the force is then calculated to 368 kN per air bellow. This is much higher than the standard air bellow can handle at 8 bar pressure. According to Contitech the air bellows are also available with reinforcement and then the maximal internal pressure of 16 bar is possible. If we assume that the effective area of the bellow is

the same as it is under 8 bar pressure, the air spring could handle a load of 449.8 kN at 16 bar pressure, which is roughly 80 kN's more than needed. When the maximal load is exerted to the bellow it would work at approximately 13 bar pressure, which is acceptable if the bellows are manufactured with the reinforcement.

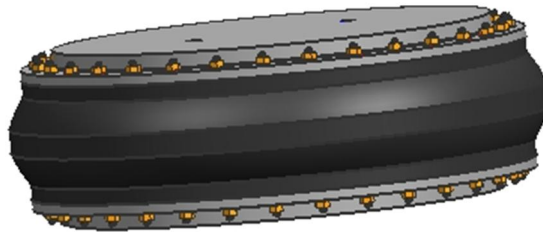
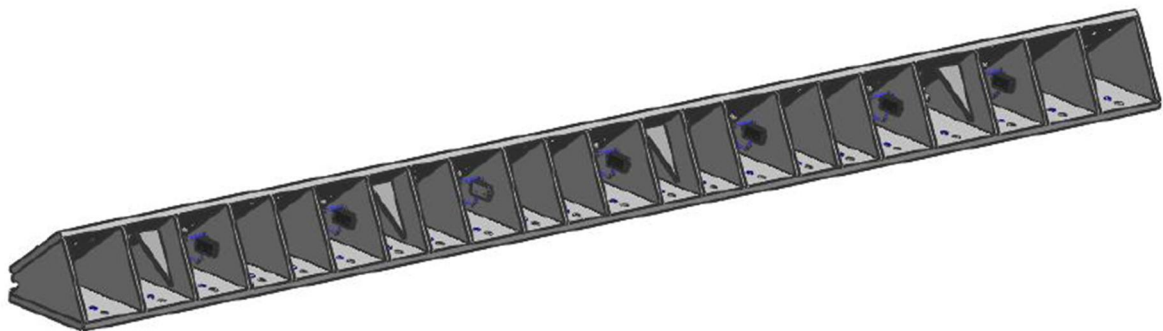

*Figure 8. Picture of air bellow with bead rings*

#### **4.2.3 Lower fixing rail**

The lower fixing rail, which will be mounted to the ship foundation, is designed as a single bracket. The advantage with having only one bracket is that all the pipes and valves can be assembled inside the bracket before mounting it to the rest of the flexible mounting system. By having all the pipes, valves and pressure sensors inside the bracket it will protect them from outer damage. The fixing rail will be mounted together with the ship foundation with 44 x M30 bolts. Figure 9 shows a picture of the lower fixing rail.

No strength calculations have been done on the fixing rail, because similar designs have been made earlier by Wärtsilä.



*Figure 9. Picture of lower fixing rail*

#### **4.2.4 Buffers**

Buffers are mechanical limiters that prevent excessive movement of the engine in case of system failure. Excessive movement could also appear during heavy sea conditions. In other words, heavy sea conditions could result in higher degrees of roll and trim than the air springs are designed for. These movements could also occur at rather fast speeds and the air springs would not maybe have time to respond as quickly as required. In this kind of case the buffers will prevent the engine from moving too much, but during normal operation the buffers will not be activated. There are also demands by the classification society that the engine must remain in its bed all the time, even if the ship turns upside down. This means that the buffers must limit the movement in all directions, which is height, lateral and longitudinal movement (viewed from the engine end). In order to limit the movement in all directions I have chosen to design two different buffers, one that limits both height and lateral movement, and another that only limits longitudinal movement. The height/lateral buffers will have an internal clearance between the both brackets. Clearance denotes how much movement is allowed of the engine before the buffers get activated and limit the movement. The clearance value depends on the type of flexible coupling that is used and on the type of pipe connections that are connected to the engine.

##### **Height/lateral buffer**

Height/lateral buffers are designed to work as pairs and will limit all movements except the longitudinal movement. This is obtained when mounting the buffers on both sides of the engine. If buffers of this type were mounted only to one side of the engine, it would be possibly for the engine to leave its bed. This buffer type consists of two separate brackets, an upper and a lower bracket. The upper bracket is mounted to the upper fixing rails and the lower bracket is mounted to the lower fixing rail, both with six M24 bolts. The clearance in this design has been set to 6 mm, which can easily be changed by inserting or removing steel shims to the buffers. The lower bracket will have a coating of a softer material to reduce the noise transfer in case the buffers become activated. The softer material is a metal mesh giving a low natural frequency together with the rest of the construction. This means that the engine could lie on the buffers and operate as normal. Figure 10 shows a picture of the height/lateral buffer.

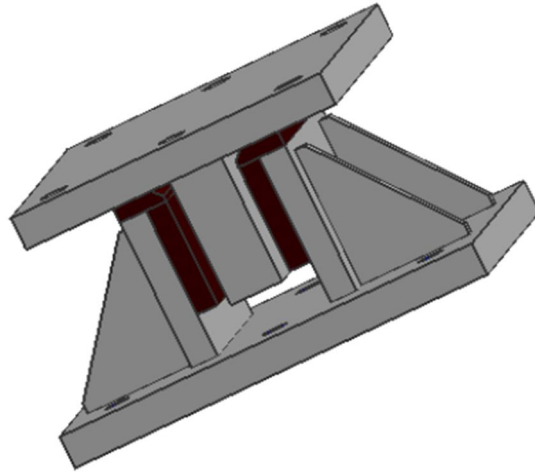

Figure 10. Picture of height/lateral buffer.

Strength calculations have been made on the weakest part which is No.1 in figure 11. Figure 11 shows how the forces will act on the upper bracket (No.1) if the ship should be upside down. The force vector  $F_{tot}$  is divided into two different vectors,  $F_a$  and  $F_r$ . Force vector  $F_a$  will exert tensile stress and  $F_r$  will exert bending stress on the upper bracket. Strength calculations for the welds on upper bracket have also been done to ensure that the stresses in the welds don't exceed the material's maximum stress. Figure 12 shows the load case for the upper bracket. The forces are assumed to be equal on all height/lateral buffers.

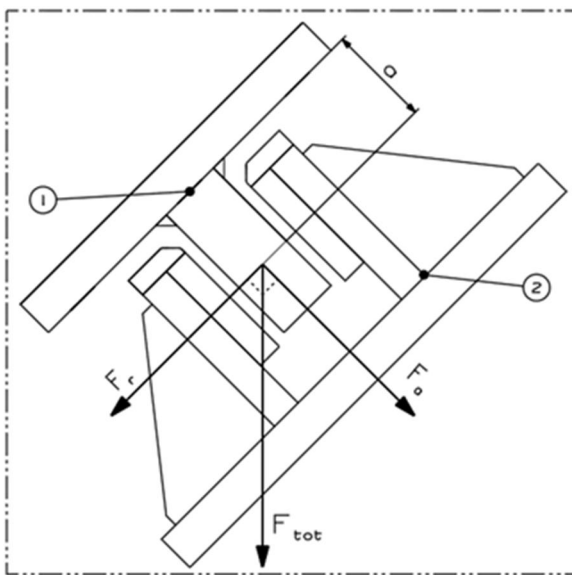

Figure 11. Forces on height/lateral buffer

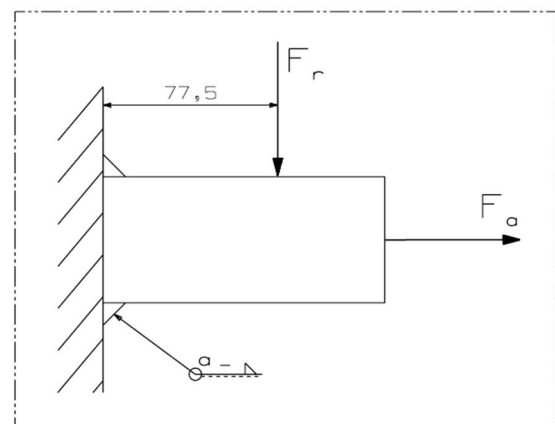

Figure 12. Load case for the upper bracket

Bracket stresses are calculated as follows:

$$F_{tot} = \frac{mg}{n} \quad n = \text{buffer amount (6)}$$

$$F_a = \cos 45^\circ * F_{tot} \quad F_r = F_a \text{ (due to } 45^\circ \text{ degree angle)}$$

$$F_a = \cos 45^\circ * \frac{180000\text{kg} * 9,81\text{m/s}^2}{6} = 208101,5 \text{ N}$$

*Tensile stress on bracket*

$$\sigma = \frac{F_a}{A} = \frac{208101,5 \text{ N}}{200\text{mm} * 56\text{mm}} = 18,6 \text{ N/mm}^2$$

*Bending stress on bracket*

$$\sigma_{bend.} = \frac{M}{W} = \frac{F_r * a}{\frac{h * b^2}{6}}$$

$$\sigma_{bend.} = \frac{208101,5\text{N} * 77,5\text{mm}}{\frac{200\text{mm} * (56\text{mm})^2}{6}} = 154,3 \text{ N/mm}^2$$

*Total stress on bracket*

$$\sigma_{tot} = \sigma_{tens.} + \sigma_{bend.} = 18,6 \text{ N/mm}^2 + 154,3 \text{ N/mm}^2 = 172,9 \text{ N/mm}^2$$

Allowed stress according to SFS 3200 for steel S355 is  $213 \text{ N/mm}^2$  which is  $> \underline{172,9 \text{ N/mm}^2}$

Weld stresses are calculated as follows:

*Tensile stress in weld*

$$\sigma_{t.comp.} = \frac{F_a * \beta * \sqrt{3}}{a * tot. weld length} \quad a = \text{Fillet weld size } 20\text{mm}$$

$$\sigma_{t.comp.} = \frac{208101,5\text{N} * 0,9 * \sqrt{3}}{2 * (20\text{mm} * 200\text{mm}) + 2 * (20\text{mm} * 56\text{mm})} = 31,7\text{N/mm}^2$$

*Bending stress in weld*

$$\sigma_{b.comp.} = \frac{\beta * \sqrt{2} * M * e}{I}$$

$$\sigma_{b.comp.} = \frac{0,9 * \sqrt{2} * 208101,5\text{N} * 77,5\text{mm} * 48\text{mm}}{2 * \left[ \frac{20\text{mm} * (56\text{mm})^3}{12} \right] + 2 * \left[ \frac{200\text{mm} * (20\text{mm})^3}{12} + 200\text{mm} * 20\text{mm} * (38\text{mm})^2 \right]}$$

$$\sigma_{b.comp.} = 79,4 \text{ N/mm}^2$$

*Total stresses in welds*

$$\sigma_{tot} = \sigma_{t.comp.} + \sigma_{b.comp.} = 31,7\text{N/mm}^2 + 79,4\text{N/mm}^2 = 111,1\text{N/mm}^2$$

Allowed stress in welds according to SFS 2373 for steel S355 is  $135\text{N/mm}^2$  which is  $> \underline{111,1\text{N/mm}^2}$

### **Longitudinal buffer**

The longitudinal buffers will only limit the longitudinal movement of the engine. They are positioned in the four corners of the mounting system. The buffers are fixed to the lower fixing rails with bolts. A rubber element will be placed between the upper fixing rail and the buffer. This rubber element will isolate the vibrations and reduce the noise transfer that occurs from the engine. The rubber elements are to be compressed before fixing the buffers to the lower fixing rails. When they are compressed they will not allow as much movement in longitudinal direction as they would if they were in normal state. When fixing the buffers to the lower fixing rail, the distance between both fixing rails should be at the operation height for the air springs. This is to avoid additional shear in the rubber elements. A picture of the longitudinal buffer is shown in figure 13.

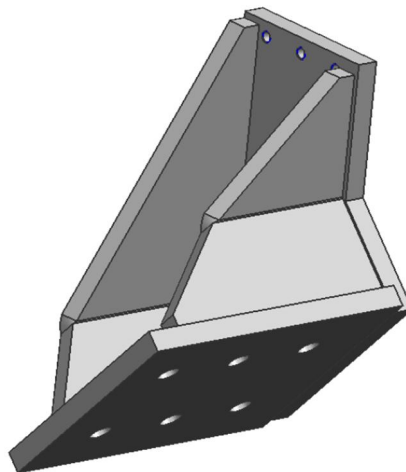

*Figure 13. Picture of longitudinal buffer*

#### **4.2.5 Transport brackets**

A stiff system is required when transporting the engine with the flexible mounting system. This is achieved by mounting transport brackets between the both fixing rails. Such a stiff system is also required when aligning the engine and the flexible mounting system. These transport brackets will also make the assembly of the air bellows to the fixing rails easier. There are four transport brackets on each side of the engine and they will be removed after the air and the control system have been activated and reset. Figure 14 shows a picture of the transport bracket.



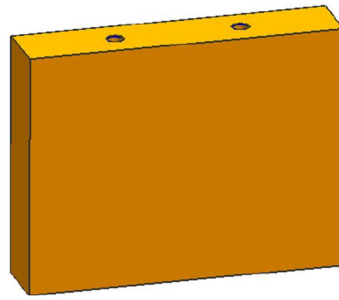

Figure 14. Picture of transport bracket

The transport brackets must be able to withstand the weight from the engine and at this moment the brackets are exposed to normal stress and shear. Figure 15 shows how the forces occur on the transport bracket. The forces are assumed to be equal on every bracket.

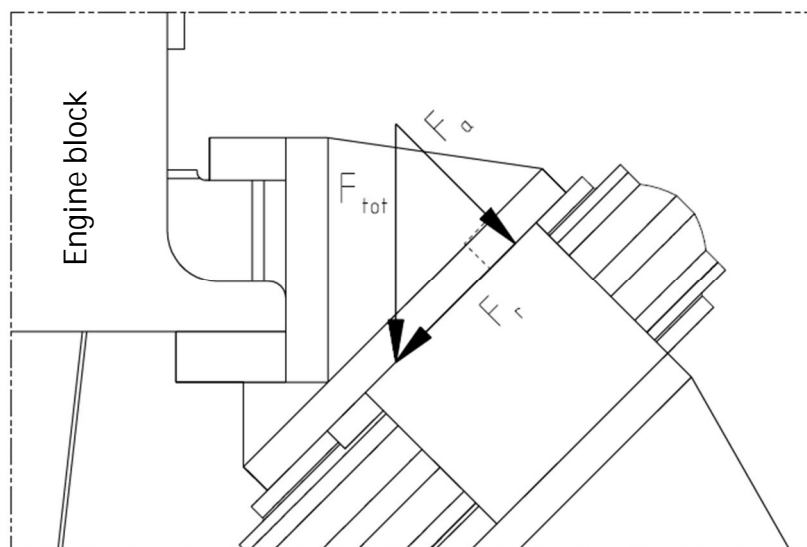

Figure 15. Sketch of transport bracket and forces caused by engine weight

Normal stress (compressive) is calculated for one bracket as follows:

$$F_{tot} = \frac{mg}{n} \quad n = \text{bracket amount (8)}$$

$$F_a = \cos 45^\circ * F_{tot} \quad \sigma = \frac{F_a}{A}$$

$$\sigma = \frac{F_a}{A} = \frac{\cos 45^\circ * \frac{180000\text{kg} * 9,81\text{m/s}^2}{8}}{286\text{mm} * 60\text{mm}} = 9.1\text{N/mm}^2$$

Shear stress is calculated for one bracket as follows:

$$\tau = \frac{F_r}{A}$$

Due to the 45 degree angle the force vectors  $F_a$  and  $F_r$  will be of the same size, therefore normal stress and shear stress will also be of the same magnitude.

The combined stress, normal stress and shear stress, is calculated with Von Mises theorem as shown below:

$$\sqrt{\sigma^2 + 3 * \tau^2}$$

$$\sqrt{(9,1N/mm^2)^2 + 3 * (9,1N/mm^2)^2} = 18,2N/mm^2$$

Yield strength for S235 thickness > 41mm = 200N/mm<sup>2</sup>

This shows that there are very low strains on the brackets.

When lifting the engine with the mounting system, the fastening bolts are exposed to a force according to the weight of the lower fixing rail. This force will exert a torque around point  $T$ , which is shown in figure 16.  $F_1$  and  $F_2$  represent the forces of the fastening bolts.

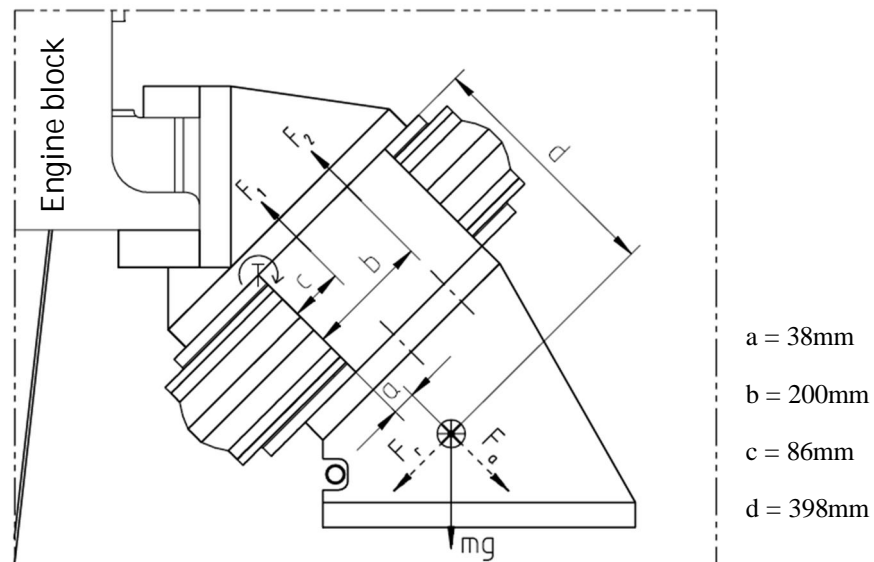

Figure 16. Sketch of transport bracket with dimensions and force vectors

The required bolt force is calculated as follows:

$$F_a = \cos 45^\circ * mg \quad F_a = F_r$$

$$F_a = \cos 45^\circ * 3000\text{kg} \times 9,81\text{m/s}^2 = 20810,2 \text{ N}$$

$$T = F_a * a + F_r * d$$

$$T = 20810,2\text{N} * 38\text{mm} + 20810,2\text{N} * 398\text{mm} = 9,07 * 10^6 \text{ Nmm}$$

$$\left. \begin{aligned} T - 4 * F_1 * c - 4 * F_2 * b &= 0 \\ \frac{4F_1}{c} &= \frac{4F_2}{b} \end{aligned} \right\}$$

$F_1$  and  $F_2$  are solved from the equation above:

$$F_1 = 4115,8 \text{ N} \quad F_2 = 9571,7 \text{ N}$$

All bolts are to be of the same size, that is why  $F_2$  determines the required bolt force.

The Safety factor against clearance is to be 1,8 (Rule of thumb, steel - steel)

$$F_{required} = F_2 * 1,8 = 9571,7\text{N} * 1,8 = 17229,1\text{N}$$

The force  $F_r$  will exert shear stress ( $\tau$ ) on the bolt. This is added to the normal stress of the bolt with Von Mises theorem.

$$\sigma_{comp} = \sqrt{\sigma^2 + 3 * \tau^2} \quad \frac{\sigma_{comp}}{FS} = \sqrt{\left(\frac{F_{req.}}{A_s}\right)^2 + 3 * \left(\frac{F_r}{A_s * n}\right)^2}$$

$$\frac{640\text{N/mm}^2}{3} = \sqrt{\left(\frac{17229,1\text{N}}{A_s}\right)^2 + 3 * \left(\frac{20810,2\text{N}}{A_s * 8}\right)^2}$$

$A_s$  is solved:  $83,5\text{mm}^2$

Effective area of bolt  $\geq 83,5\text{mm}^2 \rightarrow \text{M16} (157\text{mm}^2)$

#### 4.2.6 Valves

Two common types of leveling systems are used for the height adjustment of the air springs. The more common type used for vehicles is a pneumatic valve which senses the distance between two points via a mechanical linkage. This adds or exhausts air pressure to maintain a constant operation height. This type of leveling valve can provide accuracy to  $\pm 1,6$  mm. The other leveling system is an electronic device which senses the position of a mechanical device. The output signal from this is sent to a control circuit which then exhausts or adds air to the air bellow through a solenoid valve. This type of leveling system can control heights within  $\pm 0,03$  mm. (Firestone 2005; Airmount vibration isolation)

#### 4.2.7 Resin chocks

Resin chocks are used for to get an even surface between the lower fixing rail and the ship foundation. The resin is to be cast after the engine has been adjusted to the right position with help of the adjusting screws. After the resin is hardened, the lower fixing rail will be bolted together with the ship foundation. It is recommended to have a surface pressure of approximately  $3.5\text{N/mm}^2$  on the resin. This is achieved with 88 x M30 bolts and the engine weight. (Wärtsilä 46F product guide 2011)

The surface pressure is calculated like this:

$$P = \frac{F}{A}$$

F=Engine weight + Bolt forces      A=Resin area

$$P = \frac{180000\text{kg} \times 9,81\text{m/s}^2 + 88 \times 300000\text{N}}{2 \times 500\text{mm} \times 8260\text{mm}} = 3,4\text{N/mm}^2$$

$3,4 \text{ N/mm}^2 \approx 3,5\text{N/mm}^2 \gg \text{Approved}$

#### **4.2.8 Installation procedure**

The engine with the mounting system should be installed in the ship in this order

- Align the engine with generator or gearbox using jacking screws
- Cast resin shock under lower fixing rail
- After resin is hardened, tighten the M30 bolts with the correct torque
- Apply air pressure to the mounting system
- Activate and reset the control system
- Remove transport brackets

## 5 Discussion and conclusion

During this thesis work I have followed clear guidelines that were given to me by Wärtsilä. By following these guidelines I have reached the goal of my work. As this thesis is partly a continuation of Wasberg's (2011) thesis, I had to thoroughly study his work before I could begin the design of the mounting system. I have worked closely with the Mechanical Engineering team at Wärtsilä. It was a challenging project because of the great size of the engine, which lead to the need of big air springs. These require space and space is only limited in the engine room. By putting a lot of thought into every detail of the mounting system, the space was used in an efficient way in the design. The Mechanical Engineering team at Wärtsilä will continue developing this project.

The Wärtsilä team and I had a meeting with two different air bellow suppliers. One of the air spring suppliers is doing a more detailed calculation for the air springs to this design. The supplier also suggested that active vibration control for this kind of mounting systems could be a possibility in the future.

The goal with this thesis was to include a cost calculation, but it was not made due to various factors such as a time limit and lack of time to send out quotations to manufacturers of the different parts. Also the fact that the staff at Wärtsilä and the air spring suppliers hadn't decided on the final air spring made the cost calculation impossible right now.

Since this assignment was challenging to me, I have had to deeply study various elements of it, but thanks to that I have learned a great deal about mechanical designing.

## 6 List of sources

Airmount vibration isolation

<http://www.airsprings.cc/Firestone/Firestone%20Vibration%20Isolation.PDF>

(read 24.2 2012)

DNV

RULES FOR CLASSIFICATION OF Ships / High Speed, Light Craft and Naval Surface Craft part 4 chapter 3

<http://exchange.dnv.com/publishing/RulesShip/2012-01/ts403.pdf>

(read 17.2 2012)

Firestone 2007 Engineering manual & design guide

<http://www.firestoneindustrial.com/site-resources/fsip/literature/pdf/MEMDG.pdf>

(read 29.3 2012 )

Firestone 2005 Rail application design guide

<http://www.firestoneindustrial.com/site-resources/fsip/literature/pdf/Airail.pdf>

(read 9.3 2012)

Introduction to mechanical vibrations

<http://www.newagepublishers.com/samplechapter/001413.pdf>

(Read 20.4 2012)

Wasberg 2011

Advanced self-aligning mounting system

Wärtsilä 46F product guide 2011

## FS 2870-16 RS

## CONTI® Single Convolution Air Spring

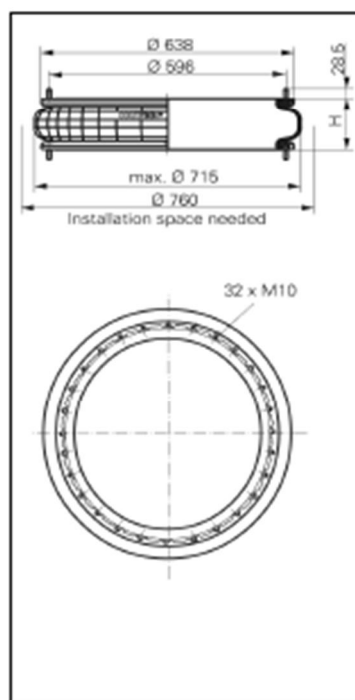

FS 2870-16 RS

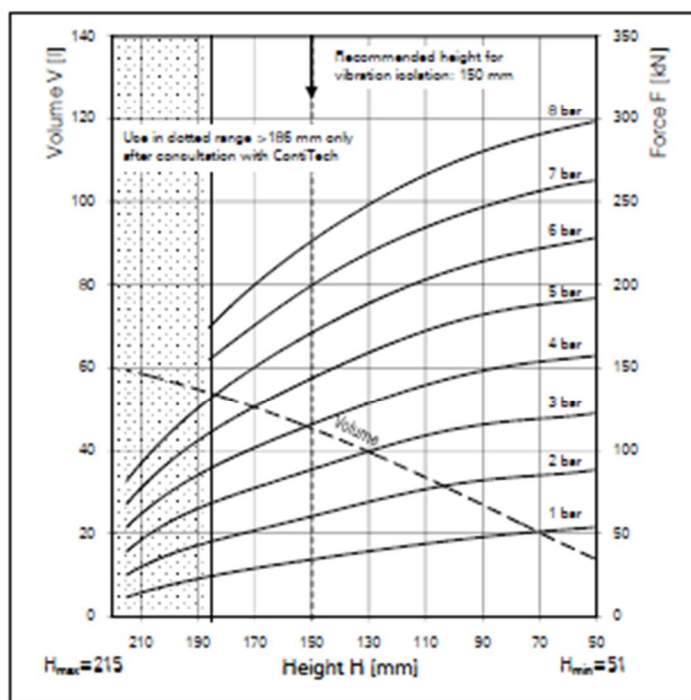

Force-height diagram

## Purchase order data

Type	Order No.
Rubber bellows only	61788
Bellows with bead rings, 45 mm bolts, nuts and washers	61901

Additional types on request

## Technical data

Min. pressure	0 bar
Return force to min. height	≤ 670 N
Overall weight with bead rings, bolts, nuts and washers	11.1 kg

## Vibration isolation - dynamic characteristic values

Design height H: recommended 150mm, minimum 130mm

Pressure p [bar]	3	4	5	6	7	8	Vol. V [l]
Force (Load) [kN]	88.7	116.9	145.2	173.2	202.1	224.9	48.5
Spring rate [N/cm]	14060	17620	21370	24830	28450	31400	
Natural frequency [Hz]	2.0	2.0	1.9	1.9	1.9	1.8	

## Pneumatic application - static characteristic values

Force F [kN]

Pressure p [bar]	3	4	5	6	7	8	Vol. [l]	
Height H [mm]	180	70.7	93.8	116.8	139.6	163.9	186.4	52.5
	160	82.9	107.9	135.6	161.0	188.0	212.7	48.0
	140	94.0	123.0	152.0	181.0	209.4	238.0	42.3
	120	105.2	135.0	166.0	196.3	228.8	258.7	37.0
	100	112.0	144.0	178.0	209.3	240.6	272.8	30.0
	80	117.8	150.9	185.4	218.1	251.4	286.0	23.6
	60	120.7	156.9	190.5	225.6	261.1	295.0	17.0

Measuring procedure: Room temperature / Force-height-data quasi-static / Dynamic data at 1 Hz

 Service instructions  
M 10 = 40 Nm