



**LAHDEN AMMATTIKORKEAKOULU**  
*Lahti University of Applied Sciences*

# BUSINESS OPPORTUNITIES OF SOLAR PHOTOVOLTAIC HOME SYSTEMS IN VIETNAM

CASE STUDY: FOSERA Co., Ltd.

LAHTI UNIVERSITY OF APPLIED  
SCIENCES

Degree program in International  
Business

Thesis

Spring 2013

Thuy Tien Nguyen Phan

Lahti University of Applied Sciences  
Degree Programme in International Business

NGUYEN PHAN, THUY TIEN:

Business opportunities of solar photovoltaic  
home systems in Vietnam  
Case: FOSERA Co., Ltd.

Bachelor's Thesis in International Business, 93 pages, 24 pages of appendices

Spring 2013

ABSTRACT

---

Vietnam has a high potential of solar energy, especially in central and south regions of the country. Together with solar water heating systems, solar photovoltaic models have become increasingly popular in Vietnam recently. Among various solar photovoltaic technologies, solar photovoltaic off-grid home systems have demonstrated to be one of the most feasible and favorable options to electrify rural areas in Vietnam.

The purpose of this study was to examine the market potential, market needs and favorable external environment with focus on rural areas in Vietnam for the case company to enter the market.

Qualitative research method was applied in this study. Data collection methods were earlier studies, books, online sources, questionnaires and semi-structured interviews with governmental authorities and experts in renewable energy to have an insight into the market and the potential of rural electrification through solar photovoltaic stand-alone home systems.

A timeline of three market entry modes was suggested for the case company to enter the Vietnamese market. Suggestions included cooperation with the Vietnamese government through national rural electrification projects in the first period, establishing distribution channels in Vietnam in the second period and a joint-venture with the purpose of establishing a manufacturing facility in Vietnam in the third period. Besides, the presence of a sales representative or intermediary who works as a coordinator and assistant between the headquarters of the company in Germany and the distribution channel in Vietnam would assist operating activities.

Key words: solar photovoltaic household systems, solar photovoltaic off-grid household systems, solar PV stand-alone household systems, rural electrification, solar photovoltaic technologies, market entry modes, rural areas

## LIST OF FIGURES

FIGURE 1. The process of deduction (modified from Business Research Methods, 2007, 11) .....	11
FIGURE 2. Theoretical Framework .....	13
FIGURE 3. Thesis structure.....	14
FIGURE 4. Porter’s Five Forces (modified from Porter, 2008) .....	19
FIGURE 5. SWOT analysis (modified from iGrad 2012).....	22
FIGURE 6. Market entry modes ( modified from Stuart Wall & Bronwen Rees, 2001) .....	24
FIGURE 7. Top 10 Emerging Markets after BRICs (2012-2017) (adapted from Global Intelligence Alliance 2012).....	31
FIGURE 8. Location of Vietnam in South East Asia (The World Factbook 2012) .....	33
FIGURE 9. Targeted power capacity proportion of different sources of energy in Vietnam by 2020 (Brown 2011).....	36
FIGURE 10. Renewable energy share of global final energy consumption in 2010 (REN21 2012, 21).....	41
FIGURE 11. Solar PV Total World Capacity 1995-2011 (REN21 2012).....	42
FIGURE 12. Solar PV Operating capacity in a number of countries all over the world (REN 21 2012) .....	43
FIGURE 13. Different types of renewable energy in Vietnam during 2011-2030 (Nguyen D. C. 2012).....	44
FIGURE 14. Sub-zones of solar energy in Vietnam (Dang 2012).....	45
FIGURE 15. Diagram of solar PV stand-alone system (adapted from Dang 2012) .....	51
FIGURE 16. Model of FOSERA PSHS (FOSERA 2012) .....	53
FIGURE 17. FOSERA Lamp (FOSERA 2012).....	54
FIGURE 18. FOSERA Phone Charger (FOSERA 2012).....	55
FIGURE 19. FOSERA SCANDLE (FOSERA 2012) .....	56
FIGURE 20. FOSERA BOP (FOSERA 2012) .....	56
FIGURE 21. SWOT’s analysis of FOSERA.....	59
FIGURE 22. Porter's Five Forces for FOSERA.....	66
FIGURE 24. Timeline of FOSERA’s market entry modes to Vietnam .....	73

## LIST OF TABLES

TABLE 1. Data collection methods.....	12
TABLE 2. Annual average solar energy density and number of sun-shining hours in various sub-zones (modified from Institute of Energy).....	46
TABLE 3. Performance capacity of SHS system with small TV, 3 lamps and radio (modified from Adelman P. 2012).....	52
TABLE 4. Performance capacity of a PSHS System with lamp, cell phone and radio (modified from Adelman P. 2012).....	53
TABLE 5. End-user Price list of FOSERA products in USD, EUR and VND (modified from FOSERA Price List 2012).....	57
TABLE 6. Main findings .....	77

## LIST OF ABBREVIATIONS & ACRONYM

ADB	Asian Development Bank
ASEAN	Association of South East Asian Nations
BOP	Bottom of Pyramid
BOO	Build-Own-Operate
BOT	Build-Operate-Transfer
BRIC	Acronym for Brazil, Russia, India and China
ECC	Energy Conservation Center
EPIA	European Photovoltaic Industry Association
EU	European Union
EVN	Electricity Vietnam
FDI	Foreign Direct Investment
GDP	Gross Domestic Product
GIA	Global Intelligence Alliance
GIZ	Deutsch Gesellschaft für Internationale Zusammenarbeit GmbH
GNP	Gross National Product
IE	Institute of Energy (Vietnam)
MARD	Ministry of Agriculture and Rural Development (Vietnam)
MoIT	Ministry of Industry and Trade (Vietnam)
NAFTA	North American Free Trade Agreement
NGO	Non-governmental organization
ODA	Official development assistance
OECD	Organization for Economic Cooperation and Development
PPP	Public-Private-Partnership
PSHS	Pico Solar Home System
PV	Photovoltaic
RE	Rural electrification
REN21	Renewable Energy for the 21 <sup>st</sup> Century
SBV	State Bank of Vietnam
SHP	Solar Hydro Power
SHS	Solar Home System
SME	Small and medium enterprise
SNV	Netherlands Development Organization
Solar lab	Solar Laboratory of Vietnam Science Institute
UNIDO	United Nations Industrial Development Organization

VBARD	Vietnam Bank of Agriculture and Rural Development
VEPF	Vietnam Environmental Protection Fund
VND	Vietnam Dong, the Vietnamese currency
VWU	Vietnam's Women Union
WB	World Bank
WTO	World Trade Organization

## CONTENTS

1	INTRODUCTION	8
1.1	Background for thesis	8
1.2	Thesis objectives, research questions and limitations	9
1.3	Research methodology & Data collection	11
1.4	Theoretical framework	13
1.5	Thesis structure	14
2	ANALYSING DIFFERENT RESEARCH METHODS AND TOOLS	16
2.1	PESTEL method for market analysis	16
2.2	Porter's Five Forces	18
2.3	SWOT method	22
2.4	Modes of market entry	24
2.4.1	Direct export	25
2.4.2	Indirect export	25
2.4.3	Licensing	25
2.4.4	Franchising	26
2.4.5	Other contractual modes	26
2.4.6	Green field investment	27
2.4.7	Acquisition	27
2.4.8	Joint-Venture	27
2.4.9	Strategic alliances	28
2.4.10	Foreign Direct Investment	28
3	VIETNAM AS A TARGET MARKET	30
3.1	Vietnam in a nutshell	30
3.2	PESTEL analysis	32
3.2.1	Political factors	32
3.2.2	Economic factors	33
3.2.3	Social factors	34
3.2.4	Technological factors	35
3.2.5	Environmental factors	37
3.2.6	Legal factors	38
4	INDUSTRY ANALYSIS: SOLAR PHOTOVOLTAIC BUSINESS IN VIETNAM	40
4.1	Solar energy industry in the world	40

4.1.1	Outlook of renewable energy in the world	40
4.1.2	Solar energy and solar technologies in the world	41
4.2	Solar energy industry in Vietnam	44
4.2.1	Energy demand and potential of solar energy in Vietnam	44
4.2.2	Rural electrification in Vietnam	47
4.2.3	Disadvantages of electricity shortage	48
4.2.4	Rural electrification potential of solar PV off-grid household systems	49
5	CASE COMPANY: FOSERA CO., LTD.	50
5.1	Overview of the company	50
5.2	Product analysis	51
5.3	SWOT analysis	59
5.4	Porter's Five Forces Analysis for FOSERA	66
6	BUSINESS OPPORTUNITIES FOR THE CASE COMPANY	72
6.1	Period 1: Direct Export Model + Cooperation with the government and NGOs in Vietnam	73
6.2	Period 2: Direct Export Model + Distribution Channels in Vietnam	75
6.3	Period 3: Joint-Venture model	76
7	CONCLUSION AND SUGGESTIONS FOR FURTHER RESEARCH	77
7.1	Main findings	77
7.2	Proposals for further research	80
7.3	Validity and Reliability	80
8	SUMMARY	81
	REFERENCES	82
	APPENDICES	94



## 1 INTRODUCTION

The introduction chapter includes five parts. The first part provides background information for the thesis topic. The second part gives an overview of thesis goal, its objectives as well as research questions which are going to be answered during the research process. Research and data collection methods are described in detail in the following part. Limitation is also shortly mentioned in this section. The next part explains the theoretical framework of the thesis. Thesis structure is drawn and illustrated in the end.

### 1.1 Background for thesis

There has been a global increase in the usage of renewable energy over the past decades. The Global Status Report on Renewable Energy in 2012 has indicated that renewable energy accounted for approximately 16.7% of global energy consumption in 2010 (REN 21). With the potential shortage of conventional energy sources such as coals, oil and other non-renewable sources in the future, many companies have taken into more consideration the capability of renewable energies to replace conventional energy sources in order to provide energy for the nations. As in the case of Vietnam, recognizing the significant losses caused by electricity shortage to the national economy and society development, the Vietnamese authorities have been putting more effort on exploiting the potential benefits of renewable energy sources to generate electricity in Vietnam. Among versatile forms of renewable energy, solar energy has been considered to be one of the main and most suitable due to geographical location of the country (Le 2009). Of various solar technologies, solar photovoltaic has become more popular in Vietnam recently. There have been so far a number of solar photovoltaic projects and new investments done through cooperation between the Vietnamese government and different organizations in this field. In rural areas, solar photovoltaic off-grid system is considered to be one of the most feasible options to bring electricity to citizens there.

Inspired by the “Market Entry to Africa” seminar course organized by Neu-Ulm University of Applied Sciences and the case company with focus on analyzing the

potential of solar energy to electrify rural areas in Mozambique using the company's products, the author has desired to write a thesis focusing on the Vietnamese market with the same case company but with different objectives. The study's objectives aim at exploring the potential of solar energy in Vietnam, figuring out the competition level of solar energy market and finding more information on rural electrification by solar photovoltaic stand-alone household systems in Vietnam. By understanding the situation of the Vietnamese market, the author would like to draw suitable market entry modes and proposals for the case company FOSERA to enter the market. Recognizing the significant effect of lacking electricity on the living standards and well-being of the people living in remote areas, the author hopes to find a feasible solution to the problem through solar photovoltaic off-grid systems in her research. Moreover, the study is also a small contribution to previous studies on solar energy market in Vietnam.

## 1.2 Thesis objectives, research questions and limitations

The **thesis objectives** are:

- Analyzing external environment factors of the Vietnamese market and internal competitive factors of the case company
- Providing the case company with updated relevant information of solar energy industry in order to understand the current developing situation of the industry in Vietnam
- Proposing different market entry options for the case company to enter the market

The **main research question** is:

What kinds of market entry modes are suitable for the case company to enter the Vietnamese rural market?

Other **sub-questions** are:

- How do legislation and law on power and energy affect the solar energy industry in Vietnam?
- What are the challenges facing foreign companies in doing business in Vietnam/In rural areas in Vietnam?
- Are there any foreign companies which are currently working in solar energy sector in Vietnam?
- What should be improved to enhance growth of the renewable energy sector in Vietnam?
- What is the best option among renewable energy technologies for rural electrification in Vietnam?
- Besides solar energy, which types of renewable energy are also suitable for rural electrification?

### **Limitations**

The research focuses only on solar photovoltaic sector and its activities in Vietnam. The development of solar energy in other countries is studied in order to provide foundation for understanding better the Vietnamese market. Other forms of renewable energy are discussed only to clarify the common development trend of renewable energy or relate to the development of solar energy in Vietnam. As the case company FOSERA manufactures stand-alone (off-grid) solar home systems as main products, the study consequently focused less on the activities of solar energy technologies at on-grid level. Focus of market segment is people who live in remote areas of Vietnam. Still, the market segment of people living in urban regions is discussed in order to provide the case company with potential market expansion in the future. Only market entry modes were proposed; financial, sales and marketing strategies were not explored.

### 1.3 Research methodology & Data collection

#### **Research methodology**

Qualitative research was applied because it allowed the author to study the solar energy market in Vietnam and the relevant issues in depth and data collection is not limited to predetermined categories as in quantitative research. Furthermore, as the research was conducted under a case study, qualitative research was essentially to enhance the ease of the study. Deductive approach was used. The deductive process was conducted as followed:

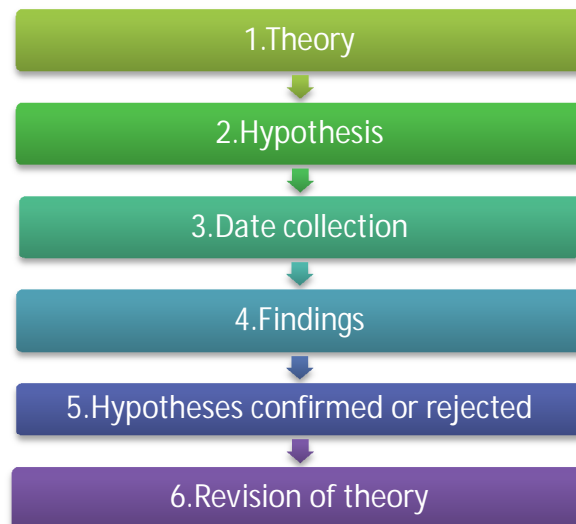

FIGURE 1. The process of deduction (modified from Business Research Methods, 2007, 11)

#### **Data collection**

Data collection methods were extracted from primary and secondary sources. Primary sources for this research included questionnaires and semi-structured interviews with governmental authorities, experts and companies in solar energy sector in Vietnam as well as the case company. Secondary sources for the research

utilized books, journals, articles, reports and early studies. This table below gives an overview of data collection methods:

TABLE 1. Data collection methods

Sources	Types of data collection methods	Unit of analysis
Primary	Case study	FOSERA Co., Ltd.
	Questionnaires, semi-structured interviews	Government authorities, experts and companies in solar energy sector in Vietnam
Secondary	Books, journals, articles, earlier reports & studies	Development of renewable and solar energy sector, solar photovoltaic household systems, rural electrification, Vietnamese market, etc.

Data analysis methods were non-quantifying methods. As a consequence, main qualitative data analysis methods applied into the research were data reduction and data restructuring.

## 1.4 Theoretical framework

Theoretical framework of the study is conducted as illustrated below:

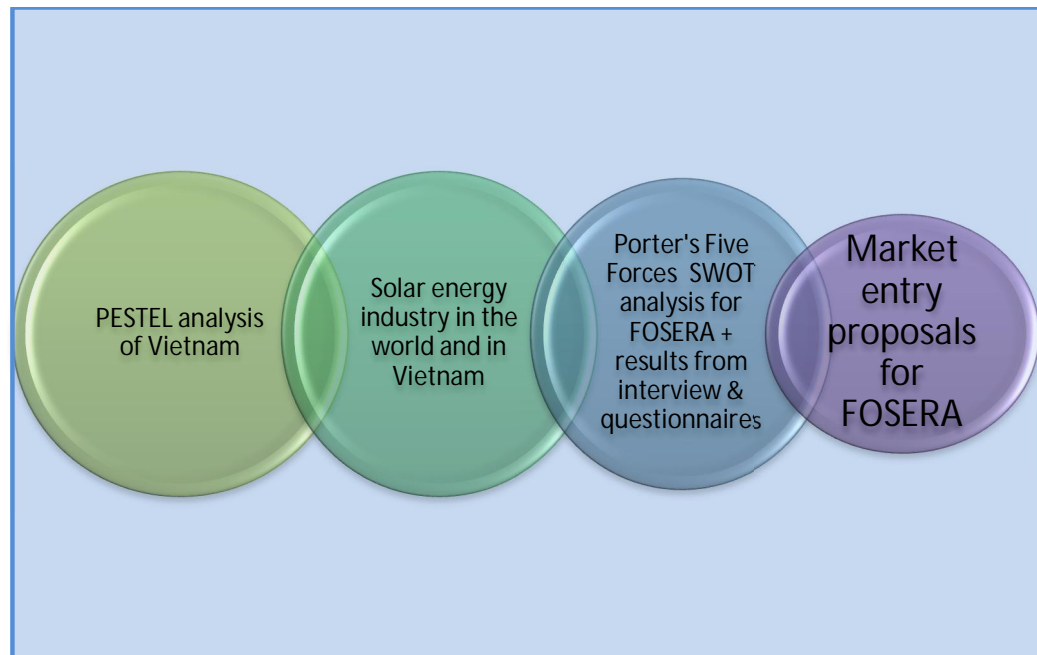

FIGURE 2. Theoretical Framework

The basis of theoretical research tools and methods are PESTEL analysis, Porter's Five Forces, SWOT method and Market Entry Modes. PESTEL analysis tool is used to analyse Vietnam's external environment factors. PESTEL is an acronym for Political, Economic, Social, Technological, Environmental and Legal. Porter's Five Forces is adopted to examine the external factors that affect the company's business activities upon entering the market. Porter Five Forces involves Rivalry among Existing Competitors, Threat of New Entrants, Power of Suppliers, Power of Customers and Threat of Substitutes. SWOT represents for Strengths, Weaknesses, Opportunities and Threats that have an impact on the company's market entry decision. Market Entry Modes classifies different types of entry strategies and the risks facing the company depending on each option. Situations of solar energy in the world and in Vietnam are examined to evaluate the potential and feasibility of solar photovoltaic stand-alone household systems to electrify

rural areas. Based on the questionnaire and semi-structured interviews, the author can exploit more thoroughly the reality of current law and legislation concerning renewable energy projects and investments in Vietnam. Furthermore, the author can observe and withdraw suggested options of market entry from interviewing different stakeholders in order to draw a set of suitable market entry modes for the case company.

### 1.5 Thesis structure

The thesis structure is conducted as below:



FIGURE 3. Thesis structure

The thesis is divided into eight chapters. Chapter 1 gives introduction to the thesis including background for the thesis, research methodology, data analysis methods, theoretical framework and structure of the thesis. Chapter 2 provides research tools and methods for analyzing the target market Vietnam and the case company. Research tools used in the study are PESTEL method, Porter's Five Forces, SWOT and Modes of Market Entry. Chapter 3 provides specific information of the Vietnamese market using PESTEL analysis. Chapter 4 observes solar photovoltaic industry in the world and in Vietnam. The empirical parts of the study are in chapter 5 and 6. In Chapter 5 the author collected information and analyzed the situation of the case company. Several proposals of market entry modes for the case company to enter the Vietnamese market are explained in chapter 6. Chapter 7 brings up main findings from the research, conclusion and suggestions for further research. Chapter 8 summarizes the whole content of the thesis and the author's final words upon the study.



## 2 ANALYSING DIFFERENT RESEARCH METHODS AND TOOLS

The purpose of this chapter is to provide a number of research methods and tools which will be applied in the empirical part of the thesis. Research methods that are going to be examined are PESTEL method, Porter's Five Forces, SWOT method and Modes of Market Entry Modes. The explanation for each method and tools is examined thoroughly in the following parts.

### 2.1 PESTEL method for market analysis

PESTEL is an acronym that represents for Political, Economic, Social, Technological, Environmental and Legal. It is widely used to analyze and to determine the risks and opportunities of a new market. Other names for PESTEL are PEST or PESTLE analysis. PESTEL analysis provides a framework for companies to understand a new unfamiliar environment and set specific tactics to mitigate the risks and exploit opportunities before establishing its business (Pestel Analysis 2012).

#### **Political factors**

Political factor refers to both politics in the traditional understanding, with rules and laws imposed by the government, and the political influences of various trade associations, trade unions, etc. on the companies (Capon 2009, 6). There are a variety of political factors to consider such as bureaucracy, environmental law, government type, freedom of the press, labor law, political change and stability, social/employment legislation, tariffs, tax policy, trade restriction, etc. (Pestel Analysis 2012). Political external environment can comprise of local, national as well as global external environment (Capon 2009, 18). At local level, influencing factors are local government, local offices of national government, local associations such as chamber of commerce, business community, etc. At national level, political factors are national government, national bodies for employers and employees. Global political factors are alliances, mutual agreements, international bodies, etc. (Capon 2009, 18-27).

### **Economic factors**

Economic refers to the influences of economic organizations and situations on companies such as banks, stock markets, currency markets, trading blocs and so on (Capon 2009, 6). There are various economic indicators such as GDP, GNP, interest rate, currency exchange rate, economic growth, inflation rate, labor costs and labor supply, unemployment rate, consumer's disposable income, etc. (Pestel Analysis 2012). Similarly with political factors, economic factors can be also divided into local, national and global level. Local factor can be local bank branches, local economy of a region or state. Economic factor also has banks, its branches and stock market at national level. Globally, economic factors are trading blocs and bodies such as EU, ASEAN, OECD, NAFTA, WTO, etc. (Capon 2009, 38-47).

### **Social factors**

Social or sociocultural factors include the demographic and cultural aspects of an external macro environment which enable firms to understand and communicate more efficiently with the natives that enable successful management across different cultures. Social factors can be health issues, population growth rate, age distribution, changes in the age and structure of the population, manners in which population react, way in which the culture of a country changes or develops, etc. (Quick MBA 2012; Capon 2009, 6). Local social factors are influences of local community and social capital such as social groups or clubs. At national level, they are demographic change and social change such as level of income, family and household structure. Global sociocultural factors are demographic of countries and cross-cultural issues such as language, behavior, culture shock, etc. (Capon 2009, 48-56).

### **Technological factors**

Companies do research on the technological aspect of a new region or country in order to catch the opportunities available for the business. The level of technological advancement can influence a firm's business in a positive or negative way as it affects the level of change that a company should make and the

capacity it should increase in order to meet its customers' demand (Pestel Analysis 2012; Capon 2009, 6). Technological factors can be R &D activity, technology incentives, technological changes, access to electricity, transportation network, etc. (Quick MBA 2012). Besides, technological factors can be the use of the Internet and world wide web, communication technology such as mobile phones, video conferencing, manufacturing technology, etc. (Capon 2009, 58-59).

### **Environmental factors**

Environmental factors consider "green issues" such as climate change, pollution, waste, etc. As climate change has become a rising issue in recent years, environmental aspects are taken more into consideration in business strategies and operations, especially for companies doing business in the renewable energy field. Environmental factors can refer to environmental protection laws and regulations, laws concerning waste disposal, legislation on energy consumption, citizens' attitude and act towards the environment (Business Mate 2010).

### **Legal factors**

Regulation and legislation of a country or region have a strong effect on the ease of doing business of a company. Legal factors can be antitrust law, consumer law, discrimination law, employment law, health and safety laws, etc. (Pestel Analysis 2012). Besides, they can be also product regulation, competitive regulation and other forms of law that affect directly or indirectly to company business activities ( Business Mate 2010).

## **2.2 Porter's Five Forces**

Porter's Five Forces tool is simple, but powerful in understanding where power lies in a business situation. It helps companies to be able to analyze its current competitive strengths and identify whether new products or business have the potential to enter the new market and make profits (Mind Tools 2012). Five Forces that were analyzed by Michael Porters are illustrated below.



FIGURE 4. Porter's Five Forces (modified from Porter, 2008)

### **Threat of New Entrants and Entry Barriers**

New entrants to an industry are a threat to companies as they have capacity and desire to gain market share that put pressure on product price, costs, investment rate, etc. to compete on the market. If the threat is high, companies must lower their product prices or make more investment in order to compete with new competitors. If the threat of new entrants is low, existing companies have more opportunities to gain profitability from the market (Porter 2008, 8).

Industries that protect high profitability level of existing firms and prevent additional rivals entering the market are called barriers to entry. Barriers can be from government, patents that restrict new entry, cost advantages, technology protection, economies of scale, time and cost of entry, etc. (Quick MBA 2012). If entry barriers are low, the threat of new entrants is high and market profitability is moderated (Porter 2008, 8). Therefore, entry barriers are advantages that existing

companies have over new entrants. On the other hand, high entry barriers are disadvantages for new comers who want to step into the new market.

### **The Power of Suppliers**

Suppliers can capture more power and value for themselves by driving up prices, limiting quality or service, or switching cost to other participants in the industry (Porter 2008, 13). As the companies need raw materials for manufacturing process, the buyer-supplier relationship between the industry and the firms is significant. The power of suppliers can lie in the number and the size of suppliers, suppliers' ability to deliver differentiated products, the cost of changing suppliers, ability of companies to switch to other suppliers, unique of suppliers on the market, little effect of industry on suppliers' revenue, etc. (Mind Tools 2012; Porter 2008, 14).

### **The Power of Buyers**

Powerful customers can put pressure on companies to lower product prices, to demand better product or service quality (Porter 2008, 14). There are different groups of customers who have bargaining power. They can be customer group who has bargaining power in negotiation or in the price of products. Customer group has negotiating advantage can be buyers who purchase products in large volume, who has little difficulties in changing vendors or who is able to produce the products by themselves if industry is too profitable. If the products are standardized or undifferentiated, this customer group also has bargaining power over the companies. The other customer group is group of those who are sensitive over product prices. It can be because of cost structure or procurement budget of the buyers, little effect of product quality on purchasing decision or little effect of products on buyers' other cost, etc. (Porter 2008, 16). Therefore, it is vital for the company to evaluate the position of its products on the market in order to set appropriate strategies towards its purchasers.

### **Threat of Substitutes**

Threat of Substitutes refers to the ability of customers to find an alternative product to a firm's product. When threat of substitute is high, there is little profitability for companies as customers have more options to choose or switch to other alternative available products. High threat of substitutes can be because of substitutes' ability to offer attractive products with lower price, lower cost of switching to other substitutes. Therefore, it is vital for companies to differentiate itself from other substitutes through better product performance, lower price, more effective marketing strategies, etc. Besides, companies should be able to alert to changes in industries, the coming of new substitutes, changes of new technologies, etc. in order to deal with the threat in an effective and profitable way (Porter 2008, 17-18).

### **Rivalry among Existing Competitors**

There are many forms of rivalry among existing competitors such as price discounting, marketing and advertising campaigns, introduction of new products, new innovation, product or service improvement, etc. (Porter 2008, 18). High level of rivalry is a disadvantage for companies in terms of profitability. Porter (2008, 18) has indicated two degrees of rivalry based on intensity or basis of competition. Intensity degree can be seen in the number of competitors, their size and capability on the market, level of industry growth, high level of exit entry that prevents companies from withdrawing from the market even when they are earning low or negative revenue, customer loyalty level, cost of leaving the market, etc. (Mind Tools 2012; Porter 2008, 18-19). The other degree of rivalry refers to the dimension of competition which is usually occurred as price competition. The reasons for price competition can be because of undifferentiated product or service, lower cost of switching to alternative products, characteristics of production such as high fixed costs and low marginal costs, perishable products, etc. Other forms of competition on dimensions are product features, brand reputation and image, delivery time, support services such as after-sales and so on. Competition can be positive in a way that each competitor strives for better service or products in order to meet customer demand and compete with others on

the market. On the other hand, a market with high competitive rivalry brings more disadvantages and challenges for a new entrant (Porter 2008, 20-21). However, with a clear understanding and competitive strategy, a company can turn the challenge of competition into its competitive advantages.

### 2.3 SWOT method

SWOT is an acronym for Strengths, Weaknesses, Opportunities and Threats. SWOT analysis is a useful tool for analyzing companies' environmental situations because it enables companies to focus on strengths, to mitigate threats and to make the most of opportunities available (Mind Tools 2012). While Strengths and Weaknesses refer to the internal environment or the situation inside the companies such as factors relating to products, pricing, costs, profitability, performance, quality, people, etc., Opportunities and Threats refers to the external environment or situation that is outside the companies such as factors relating to markets, customers, seasons, trends, competition, etc. Therefore, SWOT analysis is sometimes called Internal-External Analysis and the SWOT Matrix is called an IE Matrix (Mind Tools 2012). SWOT Matrix can be illustrated as follow:

	Helpful	Harmful
Internal	Strengths S	Weaknesses W
External	Opportunities O	Threats T

FIGURE 5. SWOT analysis (modified from iGrad 2012)

**Strengths**

Companies evaluate their own strengths from an internal point of view, from customers and the existing market to develop its competitive advantage (Mind Tools 2012). Strengths of a company can be strong brand names, reputation, cost advantages, favorable accessibility to distribution locations, etc. (Quick MBA 2012). Besides, company's strengths can be also in having competent employees and board members, modern high-tech equipment or manufacturing facilities, available grants and source of income, international experiences, etc. (Community Tool Box 2013).

**Weaknesses**

Weakness is considered a flipside of strength. Therefore, weakness of a company is the lack of strength in certain areas such as product reputation, high cost, lack of patent protection, etc. (Quick MBA 2012). Besides, weaknesses can lay in lack of international experiences, lack of competent human resources or resources, long physical distance to the market, ineffective operation systems or programs, etc.

**Opportunities**

By analyzing external environment, companies can discover new opportunities for growth and profitability. Opportunities can be new technologies, improvement of regulations and legislation, absence of international trade barriers, demographic changes, economic climate, etc. (Quick MBA 2012). Opportunities are also positive future trends, awareness of potential customers, support of the local governments, availability of funding sources and distribution channel, increase in customer demand and so on.

**Threats**

Together with opportunities, companies can encounter threats from external environment such as new legislation, presence of substitute products, competitive activity, demographic changes, channel pressure, changes in customer



preferences, etc. (Quick MBA 2012). Threats are also unavailability of funding sources or supplying chain or equipments, rising cost, increase in governmental protective mechanism, unacceptance of customers, threat to the environment, new changes in modern technology leading to slowness of adaption, obsolete thinking or outdated manufacturing facilities, etc.

#### 2.4 Modes of market entry

A company is triggered by different motives to go abroad through an internationalization process. There are many ways for a firm to enter or expand its business to a new unfamiliar market. Different market entry strategies are exporting directly or indirectly, licensing, franchising, strategic alliances, foreign direct investment, etc. A short summary of market entry modes is illustrated as followed:

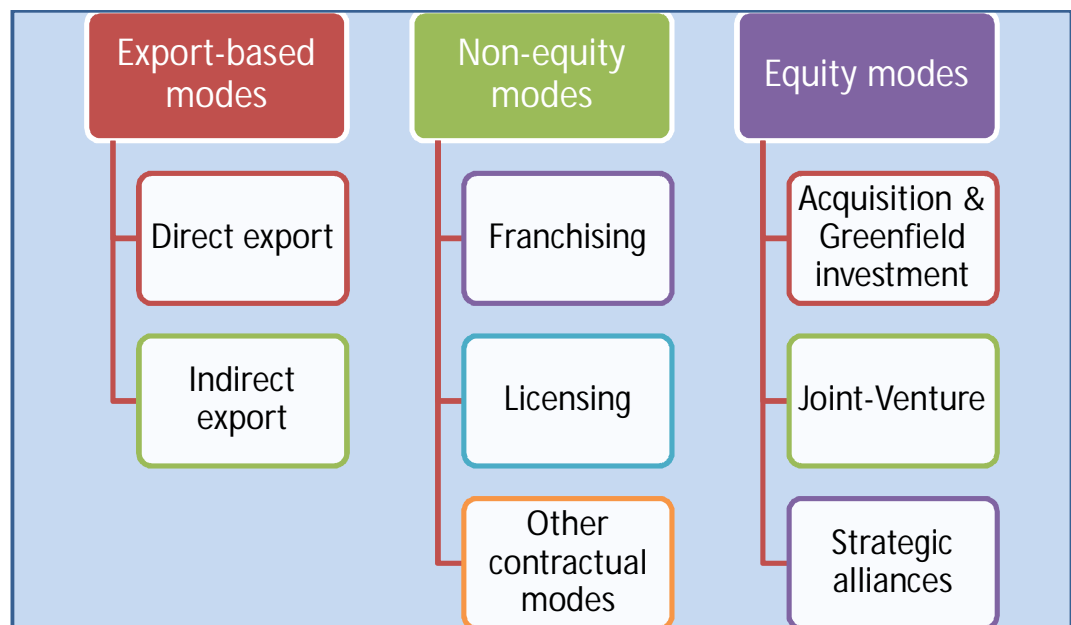

FIGURE 6. Market entry modes ( modified from Stuart Wall & Bronwen Rees, 2001)

#### 2.4.1 Direct export

Direct export are “overseas sales in which a producer or supplier controls all activities and collects all drawbacks” (Business Dictionary 2013). In export activities, products are carried from factories and stored in a center warehouse from which they will be moved to other distribution locations and finally reach the end-customers in different regions (Pelle, 2007, 107). Direct export is often used to test the country’s potential market before investing more in that country as direct export is a less expensive market entry strategy in comparison to others. One of the advantages of direct export is that a firm can directly integrate with foreign markets to develop relationships and once it has already familiarized itself with the foreign markets, it can quickly develop its competitive advantages and expand the business. One of the disadvantages of direct export can be difficulties in identifying right foreign customer segments which may be very time-consuming or costly. (Czinkota et al., 2009, 223.)

#### 2.4.2 Indirect export

In contrast to direct export, indirect export means that a firm enters a foreign market through an intermediary; the company, therefore, does not deal with foreign customers or firms directly. Intermediaries are export agents or freight forwarders who participate in international transaction. Indirect export reduces the risk of entering the new market when companies have no previous experiences or knowledge about the foreign market. However, a firm may finally grow without being engaged to the international markets nor increase their serving capabilities. (Czinkota et al., 2009, 223.)

#### 2.4.3 Licensing

Licensing refers to the entry strategy in which one firm under a licensing agreement gives permission to another company to use its intellectual property for royalty as compensation (Czinkota et al., 2009, 228). The licensed company is the licensee and the company which gives permission to intellectual property is licensor. There are a variety of licensed properties including trademarks,

copyrights, technology, technical know-how, patents, and so on. The advantages of licensing are its non-requirement of capital investment or non- involvement with foreign customers, risk reduction in lacking knowledge of foreign markets and local legislations. On the other hands, the disadvantages of licensing are the possibility of creating company's own competitors in the markets and certain limitations for future market expansion. (Czinkota et al., 2009, 229.)

#### 2.4.4 Franchising

Franchising is defined as “the granting of the right by a parent company (the franchisor) to another, independent company (the franchisee) to do business in a prescribed manner” (Czinkota et al., 2009, 230). Franchising forms can include the sales of the franchisor's products, usage of its brand or production and marketing techniques for approaching the markets. In order to succeed on the franchising business, franchisor must be able to develop and offer unique and highly recognized international products. Benefits of franchising system are attainment of new markets, financial increase and achievement over competitors. However, franchising also has its disadvantages such as difficulties in selecting franchisee and training, damaged brand image due to franchisees' uncontrolled activities and other various factors. (Czinkota et al., 2009, 231.)

#### 2.4.5 Other contractual modes

Other contractual modes can be in the form of a turnkey project-a project in which a foreign company pay local contractors for designing, construction of new facilities and training of personnel in that local country. Turnkey projects are preferred by industrial companies who specialize in complex production technologies and are interested in earning profits in the local country. The risks involved in turnkey projects are the possibility of sharing the company's secret to potential competitors and the lack of long-term profits in the country. (Wikipedia 2012.)

#### 2.4.6 Green field investment

Greenfield investment is the establishment of a new wholly owned subsidiary in a foreign country. Greenfield investment has high risk due to the high cost of new business establishment in a new country and time commitment as it takes time to find distribution networks, to run new operations and to implement suitable marketing strategies to compete with competitors on the market.

#### 2.4.7 Acquisition

Acquisition is the buying of most or all of a target company's ownership stakes in order to gain control of the target firm (Investopedia 2013). Acquisition is effective if the company wants to take control of the existing firm's operations to gain competitive advantages and expand its business to the new market. The drawbacks of acquisition might be the difficulties in integrating two different organizations with different culture, risk of higher debt, too much diversification, etc.

#### 2.4.8 Joint-Venture

Joint-venture is defined as the cooperation of two or more businesses in which there is a share of profits, loss and control in a specific field (Investopedia 2013). Joint-venture is a good way for companies to partner because it allows partnership without having to merge. Reasons for companies to form a joint venture are the potentiality of business expansion, development of new products, gaining new market, potential of sales, availability of suitable business partners, etc. Joint-venture gives companies more opportunities to grow with greater capacity, more resources, more technical expertise, and easier access to market, etc. (Joint Ventures and Partnering 2013) In some countries, high import barriers or government's restriction on foreign ownership may be the reasons for a company to choose joint venture.

There are a number of joint-venture types such as co-operation with another business in a limited or specific area, separate joint-venture business in which

each company owns shares and is involved in management, business partnership, etc. (Joint Ventures and Partnering 2013)

The advantages of a joint venture are the ability of sharing risk and cost to the business partner, obtainment of new local knowledge, technology, finance and experiences from a business partner, access to new markets and distribution networks, opportunities to learn, etc. The involving risks can be difficulties in coordination due to different objectives of business partners, imbalance in level of expertise, investments or assets, potential of conflict due to different culture and management style, insufficiency in leadership and assistance, etc. (Joint Ventures and Partnering 2013)

#### 2.4.9 Strategic alliances

Strategic alliance (or partnership) is defined as “an informal or formal arrangement between two or more companies with a common business objective” (Czinkota et al., 2009, 231). There are a number of alliance forms such as equity participation, joint venture, contractual agreement, consortia, informal co-operation, etc. In informal co-operation, partnering companies cooperate with one another without a binding contract. This can be in the form of company visit to exchange information about new products, production processes and technologies with the aim of building mutual trust and friendship. In contractual agreement, companies collaborate on joint research and development (R&D), joint marketing or production. Contract manufacturing is often applied to gain benefits of cost reduction and of focus on core competencies. On the other hand, the involving risk is that manufacturing partner might gain enough necessary knowledge and capability to become a future competitor of its current cooperator. (Czinkota et al., 2009, 234.)

#### 2.4.10 Foreign Direct Investment

Foreign direct investment (FDI) is defined as “an acquisition or construction of physical capital by a firm from one (source) country in another (host) country (Investorguide 2013). There are different kinds of foreign direct investments such

as Greenfield investments, Brownfield investments, mergers and acquisitions. As described earlier, Greenfield investment refers to the direct investment in a new facilities or expansion of existing facilities. Brownfield investment refers to investments in a used site which was previously used for an “unclean” business for a cleaner and less polluting purpose, for example, construction of new residential areas. Benefits of foreign direct investment entry mode are the opportunities of gaining greater profits, more markets, resources and efficiency, increase in firm’s controlling ability, capability of receiving direct feedback from the foreign market and high flexibility, etc. On the other hand, foreign direct investment is the most expensive and riskiest mode of market entry. (Foreign Direct Investments (FDI) 2012.)

### 3 VIETNAM AS A TARGET MARKET

This chapter begins by briefly describing Vietnam as an emerging market that attracts an increasing number of investors from abroad. The second part strives to analyze Vietnam and the country's related external environmental factors using PESTEL analysis tool in order to provide understanding and knowledge foundation for market entry mode decision and strategies in the following chapters.

#### 3.1 Vietnam in a nutshell

Vietnam is a developing country in Southeast Asia. The political and economic reform called "Doi Moi" or "Renovation" launched in 1986 has a significant meaning in the country's transformation process from one of the poorest countries in the world with per capita income of less than 100\$ to a low middle income country with per capita income of 1,130 \$ by 2020 (World Bank 2013). Since the reformation, there has been a shift from a centrally planned economy to a more market-oriented economy (Global Edge 2013). The country has recently been growing as a leading exporter of agricultural products and an attractive destination for foreign direct investment (Trading Economics 2013). Vietnam recorded the highest rate of export growth among developing countries in East Asia in 2011 (World Bank 2012). The country used to be listed as one of the fastest growing economies in Asia. However, Vietnam's recent economic development in 2012 showed the slowest growth rate since 1999 (World Bank 2012).

Vietnam is a member of Association of South East Asia (ASEAN), a member of the United Nations and several international organizations under and not under United Nations such as World Trade Organization (WTO), International Monetary Fund (IMF), World Health Organization, World Food Programme (WFP), World Meteorological Organization (WMO), World Federation of Trade Unions (WFTU), Asia-Pacific Economic Cooperation (APEC), Food and Agriculture Organization (FAO), International Maritime Organization (IMO), Group of 77 (G-77), etc. (Indexamundi 2012). The country has successfully chaired several international meetings and conferences such as Annual Meetings of the Boards of

Governors of the World Bank Group and the IMF in 2009, conference of the Association of South East Asian Nations (ASEAN) in the year 2010 (World Bank 2013).

According to the report of Global Intelligence Alliance (2012, 3), Vietnam ranked third among non-BRIC Emerging Markets that international companies plan to aim at in 2012-2017, just after Indonesia and South Africa. Below is the graph illustrating the position of Vietnam in the Top 10 Emerging Markets after BRICs during the period from 2012 to 2017.

Rank	Country	%
5	Indonesia	27.4%
6	South Africa	22.2%
7	Vietnam	20.1%
8	Mexico	18.5%
9	Turkey	17.8%
10	Argentina	10.3%
11	Chile	9.6%
12	Thailand	9.6%
13	Malaysia	8.7%
14	South Korea	8.7%

Africa
  Asia
  Europe
  Latin America

FIGURE 7. Top 10 Emerging Markets after BRICs (2012-2017) (adapted from Global Intelligence Alliance 2012)

As we can see from the figure, approximately one fifth (20.1%) of companies have shown interest in targeting Vietnam as one of their market destinations. Several reasons for companies' choice of entering the Vietnamese market are the country's cheap labor cost, potential large market with high population, and



increase in per capita income and affordability of the citizens, improvement in government policies, etc.

Despite certain achievements and international recognition during its economic developing progress, the country still needs more reforms and restructuring of the political system to have more transparent and opener economic policies, to give more opportunities for citizens in governance, to deal with upcoming international issues, to achieve its purpose of constructing a modern industrialized society by 2020 and other strategic goals (World Bank 2013.)

### 3.2 PESTEL analysis

PESTEL method is used in this chapter for analyzing Vietnam as a target market. PESTEL symbolizes for Political, Economic, Technological, Environmental and Legal. The PESTEL analysis of Vietnam strived at giving an overview outlook of the external environment of the country.

#### 3.2.1 Political factors

The official name of Vietnam is the Socialist Republic of Vietnam. The Constitution in 1992 is the highest fundamental legal jurisdiction which institutionalizes the country's political regime, rights and duties of citizens, national assembly, government, people's councils and committees, national flag, etc. The State of the Socialist Republic of Vietnam is the central organization of the political system. The State President is the Head of the State, elected by the National Assembly. The National Assembly is the highest-level representative body of the Vietnamese people. The government is the highest body of State administration which consists of Prime Minister, Deputy Prime Ministers, Ministers and other members. The judicial body of Vietnam is the People's courts including the supreme People's Court, local People's Courts, Military Tribunals and other tribunals set by law. Besides, there are many social-political organizations in Vietnam such as the Vietnamese Fatherland Front, Vietnamese Trade Union, Vietnamese Women's Union and other professional organizations (Vietnam's Embassy in the USA 2013). Map of Vietnam is illustrated below.

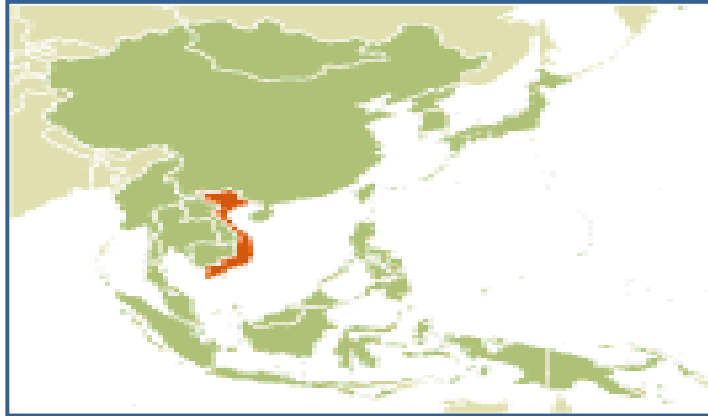

FIGURE 8. Location of Vietnam in South East Asia (The World Factbook 2012)

Geographically, Vietnam is located in Southeastern Asia, bordering the Gulf of Thailand, Gulf of Tonkin, and South China Sea. Its neighbors are China, Laos and Cambodia. The total area of Vietnam is 331,210 sq. km in which land area is 310,070 sq. km and water area is 21, 140 sq. km. The climate in Vietnam is tropical in the south and monsoonal in the north with hot, rainy season from May to September and warm, dry season from October to March. The territory of Vietnam is low, flat in the south and the north with central highlands and hilly, mountainous in far north and northwest. (The World Factbook 2012.)

### 3.2.2 Economic factors

The income level of the Vietnamese is listed as lower middle income by the World Bank (The World Bank 2012). According to the World Fact Book, estimated GDP (purchasing power parity) is \$303.8 billion in 2011 ranking 42 in the world; estimated GDP (official exchange rate) in 2011 was \$122.7 billion. GDP per capital (PPP) in 2011 was estimated at \$3,400. Composition sectors of GDP are agriculture (22%), industry (40.3%) and service (37.7%). The estimated grossed fixed investment in Vietnam in 2011 is 34.6% of GDP ranking 11th in comparison to the world. The Vietnamese budget has revenue of \$34.09 billion and an expenditure of \$37.24 billion. Taxes and other revenues contribute 27.8 % to the overall GDP. Public debt accounts for 48.8% of GDP ranking 60<sup>th</sup> in comparison to the world. Inflation rate (consumer prices) is high with 18.7% estimated in 2011 almost double the inflation rate in 2010 at 10%. The inflation

rate in Vietnam in October 2012 recorded by Trading Economics was 7.0%. (Economics 2012)

Main agriculture products are paddy rice, coffee, rubber, tea, pepper, soybeans, cashews, sugar cane, peanuts, bananas, poultry, fish and seafood. Main industries are food processing, garments, shoes, machine-building, mining, coal, steel, cement, chemical fertilizers, glass, tires, oil, mobile phones. Industrial production growth rate stands at 6% ranking at 54<sup>th</sup> in comparison to the world.

Export in 2011 was \$96.91 billion. Exporting commodities are clothes, shoes, marine products, crude oil, electronics, wooden products, rice and machinery. Exporting partners are the United States (18%), China (11%), Japan (11%) and Germany (3.7%). Import capacity in 2011 was \$97.36 billion. Commodities for imports are machinery and equipment, petroleum products, steel products, raw material for the clothing and shoe industries, electronics, plastics and automobiles. Importing partners of Vietnam are China (22%), South Korea (13.2%), Japan (10.4%), Taiwan (8.6%), Thailand (6.4%) and Singapore (6.4%). (The World Factbook 2012.)

### 3.2.3 Social factors

The estimated population of Vietnam according to the World Fact book in July 2012 is 91,519,289 people, which ranks at 13<sup>th</sup> in the world. The major cities with major population are Ho Chi Minh City, Hanoi, Hai Phong and Da Nang (The World Factbook 2012). The official language is Vietnamese; however, English has been increasingly recognized as a second language. Other languages are French, Chinese, Khmer and other mountain area languages. 85.7% of the Vietnamese people belong to Kinh (Viet) ethnic group. Other ethnic groups are Tay, Thai, Muong, Khmer, Mong, Nung, etc. The age structure is young with approximately 70% of the population from the age of 15 to 64 years old. Urbanization has been growing significantly with 30% of total population being urban population. The labor force is made up of 48.23 million ranking 13th in the world with 48% in agriculture sector, 22.4% in industry sector and 29.6% in

service sector. Population below poverty line in 2010 was 14.5%. (The World Factbook 2012)

Energy plays an important role in the functions of the economy as well as the society. As an emerging economy, Vietnam has a high consumption of energy. Energy production in Vietnam in 2011 was 106 billion kWh ranking at 34<sup>th</sup> in comparison to the world. Electricity consumption was 101 billion kWh. The amount of electricity exported abroad was 373 million kWh in 2009. Imported electricity accounted for 281 million kWh. Electricity used from fossil fuels was high up to 63.7% of total installed capacity. Electricity used from hydroelectric plants was 36.2% while electricity from other renewable sources was only 0.1% of total installed capacity. (The World Factbook 2012.)

#### 3.2.4 Technological factors

The analysis of technological aspect focused mainly on the development of current renewable energy technologies in Vietnam. According to Mr. Cuong, Director of Center for Renewable Energy and Clean Development Mechanism (Institute of Energy, MOIT), the current total electricity production from renewable energies to the national power grid is 2,000 million kWh, which is about 2% of total electricity generation capacity in the power system (Nguyen D. C. 2012). It is estimated that the power capacity of renewable energy in Vietnam will increase from 75.000MW (approximately 5.6%) in 2020 to 146.800 MW (9.4%) in 2030 (Brown 2011). The government's Master Plan VII indicated that by 2020 about 600,000 households will have access to electricity supplied from renewable power resources. Below is the pie chart showing the targeted capacity proportion of different types of power including both conventional and renewable energy sources by 2020.

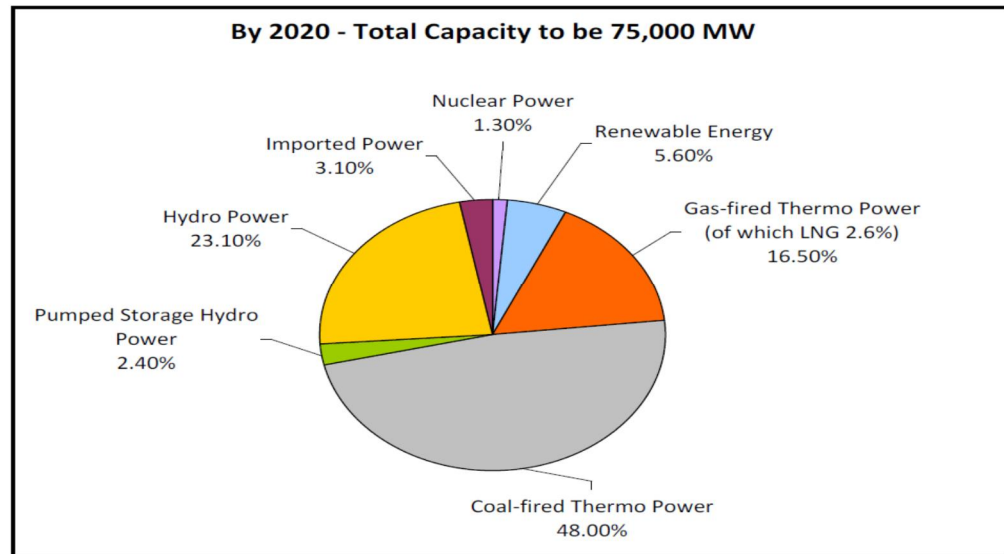

FIGURE 9. Targeted power capacity proportion of different sources of energy in Vietnam by 2020 (Brown 2011)

There are several renewable energy technologies that are in growing demand in Vietnam currently. In urban areas there are a number of the new construction of equipment and installation of solar water heating system and solar photovoltaic. For example, solar street lights for demonstration and awareness purpose. It was estimated that there were 50,000 families in southern and central parts of Vietnam in need solar PV systems (Le 2009). In the rural areas there is a need for construction of biogas digesters and improved biomass cooking stoves. Moreover, there have been many waste water treatment projects implemented in Vietnam.

Despite the increasing demand for renewable energy technologies, there are still limitations in understanding and development of renewable energy. Studies and applications of renewable energy in general and solar PV technology in particular in Vietnam are still at low level, small-scale and dispersed across the country (Dang 2012). There is a lack of service providers as well as maintenance operators (Huong 2012). Necessities and components of renewable energy technologies are mainly imported from abroad. For example, 100% of solar PV modules are imported from abroad; other components such as inverters, controllers, battery, etc. are partly designed and manufactured domestically (Le 2009, 54).

### 3.2.5 Environmental factors

The National Environmental Agency which belongs to the Ministry of Science, Technology and Environment is accountable for environmental issues in Vietnam. There are certain international and national agreements that have been signed and ratified by the Vietnamese government such as agreements on biodiversity, climate change, desertification, endangered species, environmental modification, hazardous wastes, ozone layer protection, etc. (The World Factbook 2012.). Law on Protection of the Environment was implemented in Vietnam according to Decree 80-2006-ND/CP of the government on 9<sup>th</sup> of August 2006 (vietnamlaws 2006). Besides, there are also several ratified laws such as Law of the Sea passed on June 21<sup>st</sup> 2012 (tuoitrenews, 2012), Law on Forest Protection and Development passed by the 11<sup>th</sup> National Assembly of the Socialist Republic of Vietnam on December 3, 2004. Under the Climate Change-Kyoto Protocol, the Hydro-Meteorological Service of Vietnam (HMS) which belongs to the National Office for Climate Change and Ozone Protection was assigned as a national authority for Clean Development Mechanism (CDM) which promotes CDM activities and projects related to renewable energy field in Vietnam. (Dao et al. 2011)

Despite existing legal framework and active organizations working on environmental issues, Vietnam is still facing environmental problems nowadays. Rapid economic growth has influenced many of the environmental issues in Vietnam. Urbanization, industrialization and the exploitation of natural resources through industrial planning and intensive farming are among the main factors that affecting negatively on the environment. While environmental problems in urban areas such as Ho Chi Minh City and Hanoi are air pollution, water pollution, noise pollution and hazardous waste treatment; problems in rural areas are deforestation, soil erosion, flooding in the deltas, pollution of coastal and marine environment. The World Bank has so far engaged in managing the environmental issues in Vietnam with several priorities such as issues on climate change, pollution and hazardous waste management, biodiversity conservation, etc. Still, environmental issues remain challenges for the country to deal with at the moment and in the future.

### 3.2.6 Legal factors

Generally speaking, there are good macroscopic policies and roadmap for the development of renewable energies in Vietnam. They are Law on Environmental Protection, Law on Energy Efficiency and Conservation, National Energy Development Strategy for period up to 2020 with vision to 2050, Power Master Plan VII, financial support of Clean Development Mechanism (CDM) projects through Vietnam Environmental Protection Fund, etc.

The Law on Environmental Protection was passed on November 29, 2005 by the 11th National Assembly of the Socialist Republic of Vietnam. Law on Energy Efficiency and Conservation was approved by 12<sup>th</sup> National Assembly on June 17<sup>th</sup> 2010. The National Energy Development Strategy for period up to 2020 with vision to 2050 was issued under the Decision No. 1855/QĐ-TTg on 27<sup>th</sup> of December 2007. Its content focused on the government's effort of increasing share of renewable energy to 3% by 2010, to 5% in 2020 and to 11% in 2050. Besides, it also took into consideration the establishment of renewable energy development fund for supporting investment in development of renewable energy (Nguyen D. C 2012).

The National Power Development Plan for the 2011-2020 period with a vision to 2030 (the Power Master Plan VII) having emphasis on energy security, energy efficiency, promotion of renewable energy and liberation of the power market was signed by the Prime Minister of Vietnam on 21<sup>st</sup> of July 2011 under Decision No. 1208/QĐ-TTg. It is also currently considered as the legal background for the development of renewable energies in Vietnam (Nguyen D. C 2012). The roadmap for the liberalization of electricity market in Vietnam was progressively improved as competitive generation market during the period 2005-2014, as competitive wholesaling market during 2015 to 2022, as competitive retail market after 2022 and as fully competitive retail market from 2024 onwards (Cooper 2012, 14). The result of the conducted questionnaire with several Vietnamese authorities has shown positive confidence in the application of Master Plan VII. The others also agreed that the Plan has been applied to some extent in reality (Questionnaire for Vietnamese authorities 2013).

Together with approved laws and governmental plans relating to renewable energy, there are also certain concrete governmental incentives and financial support to enhance the development of renewable energy in Vietnam. Several incentive mechanisms have been approved to enhance the development of renewable energy such as such as Feed-In-Tariff (FIT) for wind power projects, reduction and exemption of corporate income tax, value-added tax, exemption of import and export tax duties for imported equipment and machinery necessary for the creation of fixed assets of renewable energy (RE) projects (Nguyen D. C 2012). Besides, companies are also given different priorities such as priority to product consumption of CDM project in comparison to the same products which do not belong to CDM project, access to information relating to decision on product price CERS, issue of Certificate on Greenhouse gas emission reduction certified (CERS), opportunities in receiving financial support in establishing projects according to current law, incentives on tax, land lease fee, depreciation of fixed assets, investment credit of the government, priority to incentives on product prices, etc. (Nguyen T.H, 2013). In terms of corporate income tax incentive rate, newly-establish enterprises in renewable energy projects will have to pay corporate income tax only 10% for a period of 15 years. If the power projects are among large scale projects utilizing new technology and in need of investment, the corporate tax of 10% will be extended up to 30 years.

Speaking of large-scale power investment, Decision No.130/QD-TTG dated on the 2<sup>nd</sup> of August 2007 approved by the Prime Minister has specified some financial mechanisms for investment projects according to clean development mechanism. For example, the duration of power purchase agreement between the government and the investors will last up to 20 years. Besides, there are financing mechanisms for supporting the preparation of CDM project design documents (PDD) provided that the goal of increasing energy efficiency, application of renewable energy resources, reducing greenhouse gas emissions, etc. are fulfilled (VEPF 2012, 16). There is a price subsidy for solar products and Clean Development Mechanism (CDM) projects having production cost greater than the contracting electricity selling price (the case of wind power projects) (Cooper 2012). For example, the maximum support level for PDD is 30% of actual costs for preparation of PDD (VEPF 2012, 21).



## 4 INDUSTRY ANALYSIS: SOLAR PHOTOVOLTAIC BUSINESS IN VIETNAM

This chapter firstly examines the developing phases of renewable energy in the world and solar energy industry in particular. The next part describes solar energy situation in Vietnam with more focus on the development of solar photovoltaic technology in the country. Situation of rural electrification in Vietnam, the disadvantages of lacking electricity and potential of rural electrification through solar PV off-grid systems are also discussed in this part.

### 4.1 Solar energy industry in the world

This parts aims at providing general overview of renewable energy, its recent development with focus on solar energy and its technological development in developed countries as well as developing countries.

#### 4.1.1 Outlook of renewable energy in the world

Renewable energy has been increasingly used as a sustainable source of electricity generation. According to a recent report in 2012, 20.3% of global electricity is generated by renewable sources by the end of 2011. Below is the figure of renewable energy share of global final energy consumption in 2010.

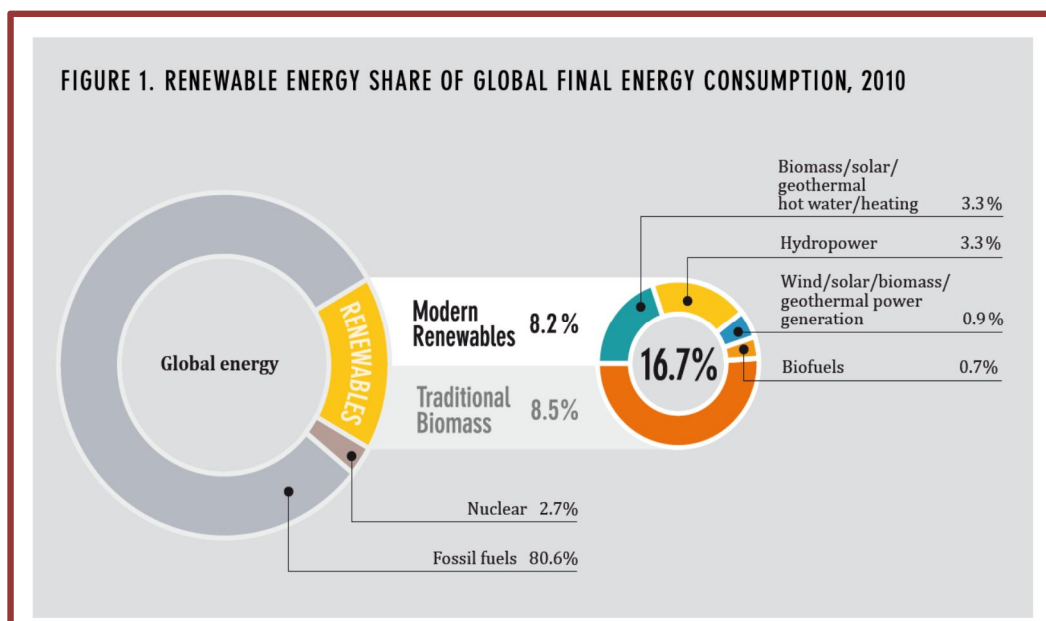

FIGURE 10. Renewable energy share of global final energy consumption in 2010 (REN21 2012, 21)

As indicated in the figure, renewable energy accounted for 16.7% of global final energy consumption in 2010. Modern renewable and traditional biomass shared the similar figure of over 8% of the total renewable energy (REN21 2012).

#### 4.1.2 Solar energy and solar technologies in the world

Solar energy technologies are technologies applied to take advantage of the sun's energy and light to provide heat, light, electricity and hot water for businesses and individuals. There are a number of advanced technologies that have been developed to utilize the potential of sun power including photovoltaic systems (producing electricity directly from sun light), solar process space heating and cooling, passive solar heating and day lighting, solar electricity, solar hot water, etc. (Renewable Energy World 2012). Among various solar technologies, solar photovoltaic (PV) electricity remained its growth trend in 2011 and it has grown faster even in the midst of financial and economic crisis. As reported by the European Photovoltaic Industry Association (EPIA) in 2012, solar PV is nowadays the third most important renewable resource after hydro and wind power in terms of globally installed capacity with an approximate amount of 70 GW installations globally (EPIA 2012). Solar photovoltaic had the fastest growth in comparison to the other renewable technologies with operating capacity increasing an approximate of 58% per year (REN21 2012).

Europe is leading in utilizing solar energy as renewable source. EPIA has reported that in 2011 solar PV was the number one electricity source in Europe in terms of added installed capacity (EPIA 2012). With 75% of all new installation capacity in 2011, Europe is still recognized as the most important market of global PV (EPIA 2012). Many European countries are leaders for solar PV applications such as Germany, Italy, the Czech Republic, Belgium, and Spain (REN21 2012).

The figure below indicates the significant growth of solar PV capacity globally during the period from 1995 to 2011.

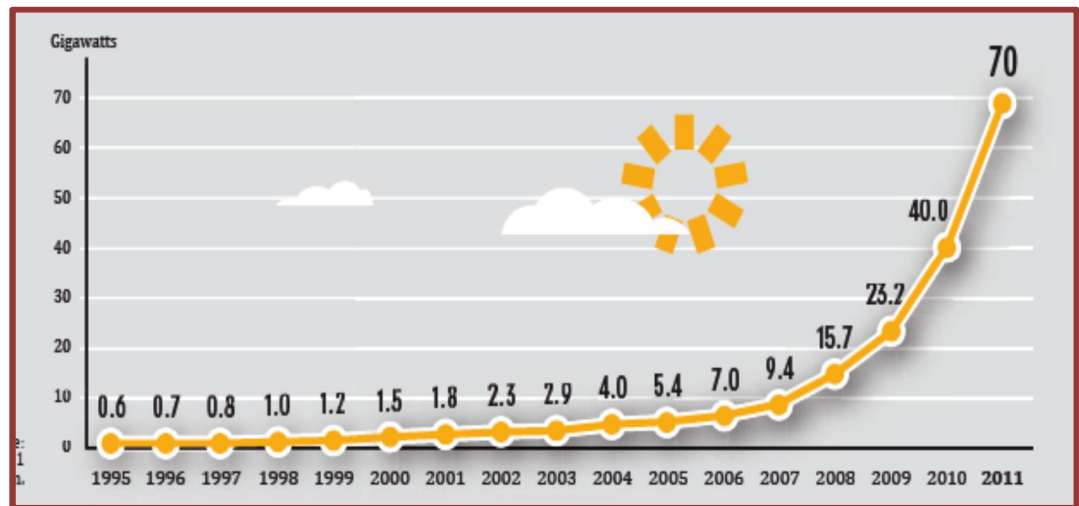

FIGURE 11. Solar PV Total World Capacity 1995-2011 (REN21 2012)

As can be seen from the figure, the installed capacity of solar PV in 2011 is almost double the figure in 2010. China and other developing countries are following Europe in expanding and developing solar PV technology. China was the on the top among European PV market in 2011 with installation capacity of 2.2 GW. The USA was in the second place with 1.9 GW installed capacity. (EPIA 2012). In terms of market, China has the largest PV market with 2.1GW capacity followed by the United States (1.9GW), Japan (1.3GW), and Australia (0.8 GW). With the quadrupled capacity in 2011, China emerged as a dominant player in Asia with 50% of the region 2011 demand. Other countries which had remarkable growth were Canada (364 MW) and India (300 MW) (REN21 2012). The figure below shows the operation capacity of solar PV in a number of countries around the world.

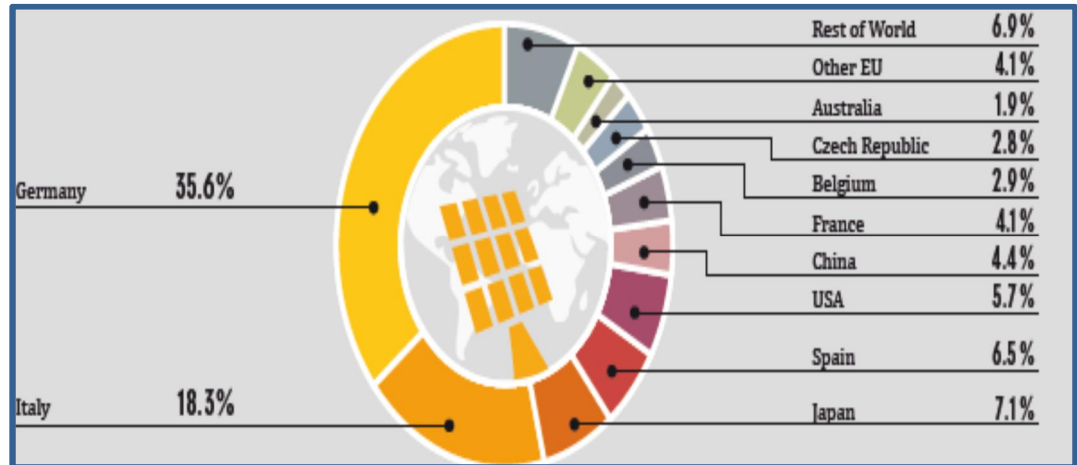

FIGURE 12. Solar PV Operating capacity in a number of countries all over the world (REN 21 2012)

As can be seen from the figure, Germany remains the largest market of solar PV applications with 35.6% of total operating capacity while Italy follows with 18.3%. Germany and Italy have covered over half of the solar PV market, and the rest is divided among other developed and developing countries.

In terms of installation scale, large-scale solar photovoltaic systems continue to be the main trend. The majority of installed PV capacity is grid-connected with the off-grid accounting for only 2% of the total global capacity. However, there is an increasing interest and growth in off-grid, small-scale and rooftop systems especially in developing countries (REN21 2012, 49).

Despite significant growth, solar PV manufacturing have been challenged by various factors such as declining policy support, the global financial crisis, tensions in international trade and so on that leads to negative outlooks or uncertainties in investing in new projects. The role of market leadership and manufacturing has been shifted towards developing countries such as China and India. Furthermore, there are also new emerging players in Asia as well as in Latin America, the Middle East and North Africa region. (REN21 2012, 22)

## 4.2 Solar energy industry in Vietnam

### 4.2.1 Energy demand and potential of solar energy in Vietnam

The energy demand in Vietnam is increasing in the future. It is expected that coal will be imported to generate electricity by 2015 (Nguyen D. C. 2012). As fossil fuels are running out and the possibility of constructing new hydro power plants is limited, it is obvious that renewable energy is one of the most potential alternatives to energy shortage in Vietnam. Below is the graph showing the development of different renewable energy sources in Vietnam in the future.

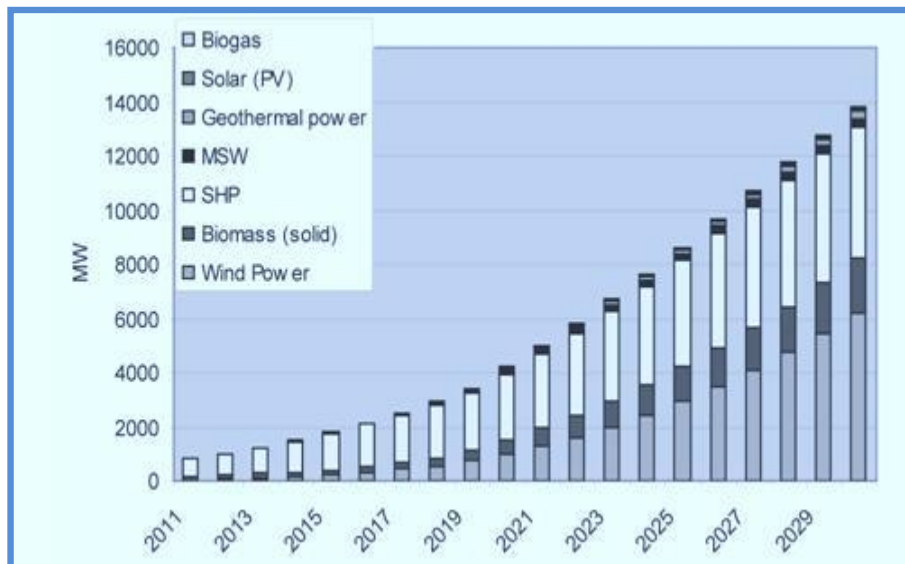

FIGURE 13. Different types of renewable energy in Vietnam during 2011-2030 (Nguyen D. C. 2012)

As can be seen from the graph, solar PV energy is expected to increase relatively just after wind energy and solar hydro power (SHP) in the near future.

Geographically, Vietnam has a huge potential for the development of solar technology and related applications. In Vietnam, the sun is a priceless and available commodity all year round. According to Trinh Quang Dung in his recent research, the annual daily solar radiation in Vietnam is 5.2 kWh per square meter

(Trinh 2009). The total sunny hours is over 2500 hours/year, and the total annual solar radiation is about 230-250 kcal/cm<sup>2</sup>. The amount of solar radiation is increasing in the southern regions, which provides a good basis for the development of solar energy applications (Nguyen D. C. 2012). Pham Dinh Thong, in his current report of solar PV technology in Vietnam, has described the variety of solar energy power in different regions of Vietnam. The whole country can be divided into 5 sub-zones of solar energy as illustrated below:



FIGURE 14. Sub-zones of solar energy in Vietnam (Dang 2012)

Five territory zones which were divided on the map are North-East, North-West, North of Central Part, South of Central Part & West Highland and Southern Part. Each zone receives a different amount of solar energy. The table below illustrates in more detail the annual amount of solar energy in different zones:

TABLE 2. Annual average solar energy density and number of sun-shining hours in various sub-zones (modified from Institute of Energy)

No.	Territory Zone	Annual aver. Solar energy (kcal/cm <sup>2</sup> year)	Annual aver. Number of shining hours (hrs/year)
1	North-East	100–125	1500–1700
2	North-West	125–150	1750–1900
3	North of Central Part	140–160	1700–2000
4	South of Central Part & West Highland	150–175	2000–2600
5	Southern Part	130–150	2200–2500
	Country average	130–152	1830–2450

The potential of solar energy has observed positive feedback from stakeholders who participated in answering to the question “What is your evaluation on the potential of solar energy in Vietnam?” Two out of three have rated solar energy as high potential to develop while one rated as medium potential. (Questionnaire for Vietnamese authorities 2013)

Speaking of solar photovoltaic technology, there are currently three kinds of PV systems that are being used in Vietnam. They are stand-alone solar PV systems, stand-alone hybrid systems of solar PV or other energy resources and solar PV on-grid system. While solar PV on-grid system is only used as demonstration systems at the National Conference Center and at the Ministry of Industry and Trade (MOIT) in Hanoi, the other two types of solar systems are increasingly used in places where there is lack of electricity grid such as mountainous or island

areas (Dang 2012, 6). Stand-alone solar PV system is the main technological application of solar energy to provide electricity in mountainous and island areas for lighting and powering of households, school, clinics, cultural houses and commune centers, for functioning telecommunication activities as well as marine communication in the form of signal electric light (Dang 2012, 5). It was estimated that Vietnam has had more than 800 kW of installed solar PV systems used for households, telecommunications, hospitals, and schools. Most of these installations are found in the southern provinces of Vietnam because of high solar radiation in those regions (Nguyen T.H 2013).

#### 4.2.2 Rural electrification in Vietnam

The difference in level of electrification in urban and rural regions in Vietnam was reported as high. It was agreed by questionnaire participants that the rate of electrification varied from different to very different between remote and urban regions in Vietnam. Solar photovoltaic off-grid system was considered as one of the most feasible options for rural electrification in Vietnam. Besides, there are also several types of renewable energies that are potential to bring electricity to remote regions such as wind energy, energy from biogas and energy from biomass, small-scale hydropower stations, etc. (Questionnaire for Vietnamese authorities 2013)

There have been a number of rural electrification projects in Vietnam such as Rural Electrification I and II sponsored by the World Bank, technical assistance and loans with low interest to expand electricity grid and build new hydro power stations by Asian Development Bank (ADB), project of biogas storage for households by Netherlands Development Organization (SNV), EEP project sponsored by the Finnish government, rural electrification project for households with no access to electricity by solar PV off-grid systems sponsored by the Korean government with special loan interest.(Nguyen N.H, 2013). Moreover, there were also rural electrification (RE) projects in rural communes of Kien Giang province such as Phong Dong, Vinh Phong, Vinh Binh Bac (Vinh Thuan district), Tan Thanh (An Minh district), Hoa Chanh (U Minh Thuong district), Hoa Loi (Giong Rieng district), Hoa Dien (Kien Luong district) and Vinh Dieu(



Giang Thanh district) with total expenses of over 30 billion VND. There were RE projects where the Vietnamese government bought 6 electricity generators for 6 island communes including Tho Chau anh Hon Thom (Phu Quoc province), Lai Son (Kien Hai province), Hon Nghe and Son Hai (Kien Luong province) and Tien Hai (Ha Tien province). The government has also implemented RE projects for Khmer ethnic minority groups in 3 communes of Giong Rieng district, 26 communes of Chau Thanh, An Bien, Giang Thanh and Go Quao district with total capital of over 100 billion VND to electrify 15.000 households, among which about 9.450 households of Khmer ethnic minority group. There was also RE project in rural communes of Bac Giang province in which the local authority has made investment in building new electricity cab systems to electrify 94 rural villages and hamlets of 24 communes of ethnical minority groups in mountainous areas belonging to Son Dong, Luc Ngan, Luc Nam, Lang Giang, Yen The district with total capital of 229 billion VND within period from 2012-2015. Besides, EVN also has implemented RE projects for villages and hamlets in Tay Nguyen highland areas. Last but not least, Distribution Efficiency Project (DEP) with the aim of improving the effectiveness of on-grid electricity distribution system attached to the on-grid systems to rural areas has been conducted with total capital of 724.8 million VND with loans from other international organizations such as World Bank (488.9 million VND) (Nguyen T.H, 2013)

#### 4.2.3 Disadvantages of electricity shortage

There are many disadvantages of lacking electricity. Firstly, it prevents the possibility of improving living standards in many aspects such as education, career, health, etc. In remote areas, kerosene and candles are used for light; dry cell batteries are used for radio. The brightness level of kerosene lamps is low and the usage of kerosene lamps and candles produce smoking air inside the house. Low education can create many social problems such as criminal and trafficking activities, increase in birth rate, low quality of life and life expectancy. Those problems can be alleviated through rural electrification as it improves living standards by creating more jobs and services, reducing the negative impact of the use of kerosene lamp on health and local environment.

#### 4.2.4 Rural electrification potential of solar PV off-grid household systems

As rural areas are often remote mountainous areas or islands where the on-grid electricity system cannot reach, solar PV off-grid system is a feasible solution to electrify those places. It provides power for domestic activities such as lighting, cooling, cooking and information exchanging through means of communication. Working activities such as sewing, social public activities such as education, health centers, post offices are also benefited from solar PV systems. Therefore, solar PV small-scale systems bring significant benefits economically, socially and environmentally. Economically speaking, the application of solar PV in rural areas is likely to bring benefits for end-users, micro, small and medium-sized enterprises. Improved condition by solar PV systems enables people to study and generate income activities after dark. The use of cellphone charged by solar energy engages more social communication and information exchange. For medium-sized enterprises, it is their chances to sell the solar products and improve their businesses. Other benefits are improved health and safety for end-users, improved gender equality, etc. (Reiche et al., 2010)

## 5 CASE COMPANY: FOSERA CO., LTD.

This chapter includes four main parts. The first part provides general information about the case company FOSERA. The second part describes different types of FOSERA products, their features and functions. SWOT analysis is used in the next part to analyze the company's internal and external factors. The last part uses Porter's Five Forces tool to examine the company's position and external environmental players upon its entrance to the Vietnamese market.

### 5.1 Overview of the company

FOSERA GmbH & Co.KG is one of the leading innovators in the renewable energy electronics sector and a global manufacturer of PV system used for the generation of light and electricity (Adelmann C. 2012). Founded in 2009, FOSERA developed its first solar home system named the "FOSERA Pico Solar Home System" (PSHS) and is being used all over the world today. The company's vision is to electrify Africa, Asia and Latin America. Its mission is to become global market leader in the field of factory-made "stand alone" solar systems.

FOSERA's headquarter is in Illerkirchberg (Germany) and its worldwide distributor are in Afghanistan by Sonnen Plus GmbH, Germany by Sol-Expert, India by Auroville Energy Products, Mozambique by Sonnen Plus GmbH, Pakistan by Sonnen Plus GmbH, Peru by Nemetsa and Sri Lanka by Suryavahini (Pvt) Ltd. In November 2012, FOSERA announced the news on its success of establishing the first Pico Solar Home System assembly line in Sub Saharan Africa in commercial production. (FOSERA 2012)

According to the general manager of FOSERA Ms. Catherine Adelmann, the company's general market entry strategy is to find a local dealer who has already had some experiences in the market, for example, mobile phone provider or retailer. The advantages of cooperating with local dealers are benefits of existing networks and current know-how in the field. The company also tries to train local entrepreneurs who go into the field, sell and repair the products to ensure the maintenance of the company's products. (Adelmann C. 2012)

## 5.2 Product analysis

In order to understand the products of FOSERA in detail, it's good to understand different technical terms for solar products. They include stand-alone solar PV system, solar home system and Pico solar system.

A stand-alone solar PV system consists of 5 main components: solar PV array or modules, Charge Controller for controlling the charge and discharge processes to battery bank, Battery Bank for storage of electricity, Inverter to invert the DC current from PV or battery to AC current, and Loads (DC and AC). The photo below illustrates the typical diagram of solar PV stand-alone system. (Dang 2012, 7)

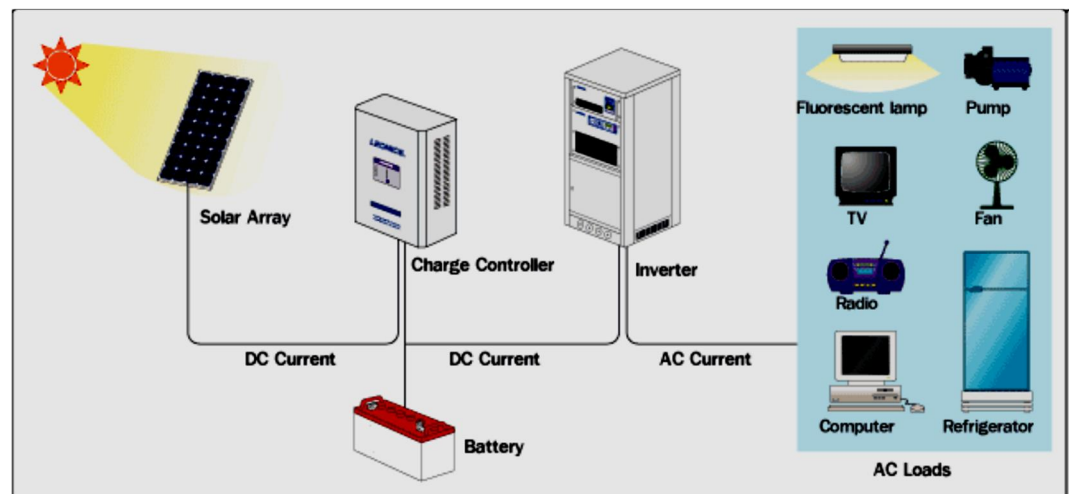

FIGURE 15. Diagram of solar PV stand-alone system (adapted from Dang 2012)

A Solar Home System (SHS) is a combined system of solar PV panel, battery and charge controller that provide a modest amount of electricity to households particularly in rural or remote regions that are inaccessible to the electricity grid (REN21 2012,166). A typical SHS for rural families consists of PV module of 50-70 WP, battery (12 V (50-70) Ah, lead acid), loads such as energy saving lights (12VDC-12W), TV or radio (Dang 2012, 8). A typical DC loads for rural electrification includes light (100-1000lm) 1 W-15W, radio/cassette 0.2W-5W,

cellphone 1Wh/day, TV (15”) 15W, refrigerator 50W (150Wh/day) (Adelmann P. 2012). In a larger scale, a solar home system for rural community facilities such as post office, military offices consists of PV module of 400-5000WP, battery (12V, 24, 48V)/ (200-2000) Ah and loads such as lighting lamps, TV, radio, amplifier and other specific equipment (Dang 2012, 9). A solar home system with small TV, 3 lamps and radio can cost approximately 100 \$ (= 2,075,610 VND). (1 USD=20,756.1 VND (OANDA, 2013). Below is the table showing the performance capacity of the system:

TABLE 3. Performance capacity of SHS system with small TV, 3 lamps and radio (modified from Adelmann P. 2012)

Load	Piece	Power(W)	Service	Usage (h)	Energy (wh/d)
Light	3	1	100lm	3	6
Radio	1	0.2		3	0.6
Cell phone	1	1		1	1
TV 8 “	1	4	8 “	3	12
				Sum	19.6
				Ah/day	1.63

A Solar Pico System (SPS) is a very small solar household system comprised of a solar lamp or a mean of technological communication such as cellphone with a power output of 1-10W and a voltage up to 12 volt (REN21 2012, 166).

Illustration of a FOSERA PSHS (Pico Solar Home System) model is found below.

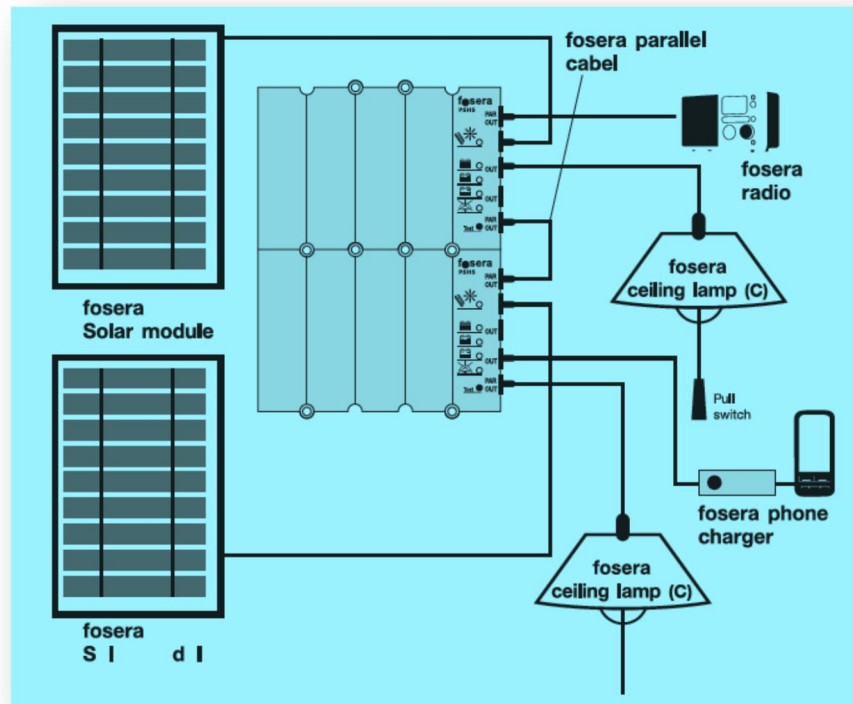

FIGURE 16. Model of FOSERA PSHS (FOSERA 2012)

A Pico Solar Home System with lamp, cell phone and radio can cost 50\$ (without load). The table below indicates in detail the performance capacity of the system.

TABLE 4. Performance capacity of a PSHS System with lamp, cell phone and radio (modified from Adelman P. 2012)

Load	Piece	Power (W)	Service	Usage (h)	Energy (Wh/d)
Light	1	1	100lm	3	3
Cell phone	1	1		1	1
Radio	1	0.2	15 "	3	0.6
				Sum	4.6
				Ah/day	0.38

As we can see from the table, the energy consumption of PSHS is relatively small approximately 4.6 Whs per day. Therefore, the system is highly suitable for people living in remote areas who consume only a small amount of electricity for their necessary daily lives.

### **FOSERA's products**

The following describes different types of FOSERA's products in detail. The company's products are Pico Solar Home Systems FOSERA PSHS 2800/4200/7000. Besides, the company's products also include FOSERA Lamps, FOSERA Phone Chargers, FOSERA Radio, FOSERA SCANDLE and FOSERA BOP. FOSERA PSHS is a Pico solar home system for domestic use such as light, radio and cell phone. The product's solar module capacity is from 1.5 to 5W. The product can be extended by parallel connection. Its user price is between 49 \$ and 99 \$ (between 1,020,572 VND and 2,061,972 VND). A similar product with bigger electricity capacity is LSHS System (12V). It is also solar home system for domestic use. The product is used for several lights, radio, cell phone and TV. Its solar module capacity is from 10 to 20W. The product can be extended by parallel connection. Its user price is 199\$ (approximately 4,144,772 VND).

FOSERA Lamps have three models FOSERA Lamp 50, FOSERA Lamp 100 and FOSERA Lamp 200.



FIGURE 17. FOSERA Lamp (FOSERA 2012)

PSHS Phone Charger is used to charge mobile phones of almost any phone brands that are available on the market.



FIGURE 18. FOSERA Phone Charger (FOSERA 2012)

FOSERA Radio is a low power-consuming device. It has dual power input which enable powering by the PSHS system or normal batteries.

FOSERA SCANDLE is a small light system used for domestic and mobile use such as light, radio and cellphone. Its solar module capacity is from 0.5 to 1.5W. User price for FOSERA SCANDLE is between 15\$ and 49\$ (between 312,420 VND and 1,020,572 VND; 1 USD= 20,828 VND) (The State Bank of Vietnam 2012).





FIGURE 19. FOSERA SCANDLE (FOSERA 2012)

FOSERA BOP is company's new product. It is a small light system for domestic or mobile use with night-light function. Its solar module capacity is from 0.5 to 1.5W. There are active and passive versions of BOP. Its user price is between 10 \$ and 20 \$ (between 208,280 VND and 416,560 VND).



FIGURE 20. FOSERA BOP (FOSERA 2012)

Another new innovative product is Solum Street Light which is ultra-efficient street light for public use. Solum Street Light is less expensive than conventional

street lights and provides intelligent light control. Its solar module is from 10 to 20W. The product's user price is from 499 \$ (approximately 10,393,172 VND).

General features of FOSERA products are the usage of high efficient long lasting LEDs and Li Fe PO Battery which can last up to six times longer than a Pb battery. Besides, intelligent system and battery management is also part of FOSERA's product features. (Adelmann C. 2012). Most of FOSERA products are easy to extend according to customers' demand. All systems for domestic lighting are compatible. As the products were developed with user-friendly and simple features, customers do not need to have specialized knowledge or know-how in order to be able to use the products. Furthermore, as the products are oriented sold to users in remote areas, the company also offers form of financial assistance for customers to buy the products step by step (Adelmann C. 2012).

This table shows the price of FOSERA products calculated in USD, EUR and VND currency using the exchange rate information issued by the State Bank of Vietnam on the 14<sup>th</sup> of November 2012(1\$= 20,828.00 VND); 1\$=0.75031 € (OANDA 2013)

TABLE 5. End-user Price list of FOSERA products in USD, EUR and VND (modified from FOSERA Price List 2012)

Product	Packing unit (pieces)	Weight/packing unit (kg/unit)	Pieces/20' Container	Remark	Price/ piece (\$)	Price/ Piece (€)	Price/piece (VND)
<b>PSHS 2800</b>	100	1.5	2,500	System incl. Lamp 100	52.89	39.68	1,101,592
<b>PSHS 4200</b>	100	1.5	2,500	System incl. Lamp 200	69.31	52.00	1,443,588
<b>PSHS 7000</b>	100	1.9	2,500	System incl. Lamp 200	89.37	67.06	1,861,398

<b>SCANDL E 25</b>	100	0.9	5,000	System with built in table lamp (25lm)	22.80	17.11	474,878
<b>SCANDL E 75</b>	100	0.9	5,000	System with built in table lamp (60lm)	31.01	23.27	645,876
<b>SCANDL E 200</b>	100	0.9	5,000	System with built in table lamp (160lm)	41.04	30.80	854,781
<b>Lamp 50</b>	100	0.4	12,250	Lamp with 40-50lm	10.76	8.07	224,109
<b>Lamp 100</b>	100	0.4	12,250	Lamp with 70-90lm	14.59	10.95	303,880
<b>Lamp 200</b>	100	0.4	12,250	Lamp with 130-160lm	20.06	15.05	417,809
<b>Radio</b>	100	0.1			10.03	7.53	208,904
<b>Phone Charger</b>	100	0.1			5.29	3.97	110,180
<b>Ferry Light</b>	100	0.2		Single color	6.20	4.65	129,133
<b>Ferry Light</b>	100	0.2		Multicolor	7.11	5.34	148,087

### 5.3 SWOT analysis

SWOT represents Strengths, Weaknesses, Opportunities and Threats. SWOT is used to analyze the internal and external factors of FOSERA in order to understand the company situation upon entering the Vietnamese market. Below is the chart summarizing FOSERA's SWOT analysis.



FIGURE 21. SWOT's analysis of FOSERA

#### **Strengths**

FOSERA's strengths lie firstly in its innovative solutions and product quality. Innovative Li-Battery-Technology enhances life span as well cycle life of the batteries. Besides, the lifespan of the solar cell is also increased up to 20 years due to the application of crystalline cell technology. LED technology enhances significantly the efficiency and brightness of the lamps (1W each) up to 20W as bright as an incandescent lamp. The system can be combined easily into larger-

scale PSHS solar home system with just a plug and play connection. Still, the products are designed as portable and versatile for various purposes. For example, SCANDLE 160 can power not only Radio but also cell phone; it can be used as hanging lamp, wall lamp, ceiling lamp, ambience light or portable torch for long outings. In the case of FOSERA PSHS, the system also enables easy extension and installation with many efficient necessary appliances such as lamps, fan, radio, phone charger. Moreover, the company has continually improved its product features through R & D activities, consultancy with experts and engineers as well as listening to customers' demand and expectation (FOSERA 2012).

Another strength is in the company's international market experience. Within two years since its foundation, the company has established its presence and business activities in a number of foreign countries such as Cambodia, Indonesia, the Philippines, Bangladesh, Malaysia, Afghanistan, Pakistan, Iran, Iraq, Tanzania, Ethiopia, Mozambique, Malawi, Nigeria, India, Thailand, etc. (Adelmann C. 2013). The company has established good contacts and business partnerships with distributors and other stakeholders in those countries. Distributors have trust and confidence in the products; thus they are more engaged and motivated to bring FOSERA products to the rural markets. The company is able in advertising itself as a world's leading company in delivering energy solutions to rural areas of the world through cooperation with universities and participation in various exhibitions in solar energy field.

In addition, the company has been managing its supply chain well. It has trustworthy suppliers of different product components. The manufacturing and supplying process are going well currently in Thailand, China and India. (Adelmann C. 2013) Besides, the company has successfully established a new manufacturing assembly line in Sub-Sahara region. The company has ability in management coordination; therefore, the supplying chain in various countries shows positive signs.

## **Weaknesses**

One of the weaknesses of the company is its lack of local knowledge and experiences with the Vietnamese market. As Vietnam is different in political and administration system with other countries, success in Vietnam requires different strategies and business roadmap. FOSERA has so far not yet established any contact with the Vietnamese market. One of the prerequisite in doing business in Vietnam means having good network of relations and business contact. A motivated, engaged and qualified person with good network will enable the company to enter the market more easily. The issue can be solved through establishing contact and network with potential students who are studying and living in Germany by means of exhibitions, seminars, etc. It's also important that those students have intention in coming back to Vietnam after finishing their study.

Lack of local knowledge and understanding of the administrative system also means difficulties in dealing with the problems of corruption, bribery and bureaucracy in Vietnam. As Vietnam is listed as one of the most corrupted countries in the world's rank, it's a big hindrance for the company to enter the market without any notice or expectation. The positive sign is that the rate of corruption or bribery in energy sector, especially in the rural electrification area, is relatively low (Dinh 2013). A person who has previous experiences dealing with the issue of corruption and bribery is needed in this case in order to ease the market entry process.

Despite innovative features and ability of extending the solar household systems quite easily, the company's products have some limitations which might be a disadvantage in comparison to other competitors. For example, FOSERA household systems are able to extend and be connected to other FOSERA loads such as radio, lamps, phone chargers or refrigerators. Still, there have not yet loads such as TV, DVD players, fan, etc. As far as the author has done the research on the Vietnamese market, there are a few companies who offer solar household systems in larger scale and more options which might attract more attention of purchasers in urban areas.

Another disadvantage which should be taken into consideration is long distance barrier. Despite the fact that FOSERA has managed its distribution channels well in many foreign countries, the company might encounter difficulties in communicating, managing and assisting stakeholders and business partners in Vietnam. Long-distance communication depends much on the Internet and online systems such as email, software programs; yet, there is a high possibility of communication barriers via those systems in Vietnam because of the malfunction of the unreliable online means of communication such as email, website, etc.

Another disadvantage of FOSERA products is the price. The product price is still high to reach the end-users who are mainly from the bottom of the pyramid. It is estimated that there is still 18.2 % (approximately 16.1 million people) whose income is listed as low (below 2\$/day) in Vietnam in 2011 (Brookings 2012). Therefore, without government financial support, the products cannot approach customers in rural areas directly and easily.

Last but not least, as solar PV technological solutions are not yet common on the market, the potential customers or end-users in Vietnam are unaware of FOSERA's products. Therefore, it takes time for the company to advertise its image and build mutual trust. Several suggestions are cooperating with Vietnamese universities, non-governmental organizations such as Vietnam's Women Union, national and local authorities of provinces, etc. to run different trade fairs, seminars, exhibitions, demonstration presentation, shows, etc. to advertise the products as well as to establish business networking.

### **Opportunities**

Together with innovative technology and high-quality products, FOSERA has a good reputation and image as a company from Germany. Up till now, there are not yet any European companies with solar home system solutions on the Vietnamese market. There are currently several companies such as SELCO and Solar World with similar range of products on the Vietnamese market. Therefore, the company has one important advantage entering the market as a pioneer from Germany. Being a pioneer might bring challenges to the company; however, the opportunity of becoming a leading reliable foreign company in supplying solar

PV stand-alone and household systems and gaining the potential market are higher. Furthermore, as German products are generally well appreciated in Vietnam as with high-quality, excellent innovative design and high durability, FOSERA can gain more easily the awareness and acceptance of the Vietnamese government as well as the potential end-users.

Another opportunity is the improvement in legal framework and laws that support the development of renewable energy in general and solar energy in particular in Vietnam in the future. Even though there are still lacks of concrete laws empowering the development of renewable energy on the market, it is likely that the laws on renewable energy in Vietnam and other relevant legislations will be approved in the near future. For example, the Master Plan VII has been put into practice recently (Dam 2013). Most of the authorities and experts interviewed by the thesis author also showed positive attitude about the improved practicality and reality of laws in the near future.

The potential large undiscovered rural markets in Vietnam give another opportunity for the company upon entering the market. Mr. Hai, Deputy Director of New and Renewable Energy Department in Vietnam, has stated that there is still approximately 3% of households in Vietnam (about 2,745,578 Vietnamese people) lacking access to electricity (Nguyen N. H. 2013). The Vietnamese population in July 2012 was 91,519,289 (The World Factbook 2012). In addition, solar PV off-grid systems on small and medium scale was listed by the government as one of the most feasible options among other renewable energy solutions such as hydropower in small and medium scale in order to achieve the goal of 100% electrified households in 2020 set by the Vietnamese government (Nguyen N. H 2013). Mr. Dam, Director of Electricity Authority Department in Hanoi, additionally insisted that he has an absolute confidence in the success of solar PV off-grid small -and -medium-scale systems in Vietnam if companies run the business with right motives, enthusiasm and good strategies. Moreover, he also indicated that there have been not yet many results of solar PV on-grid systems, which means solar PV off-grid system is more practical than on-grid solar PV systems in rural electrification in Vietnam (Dam 2013). Thus, accessing



the Vietnamese market gives the company a high potential of more profits, more expanded markets and better international image.

Another important opportunity for the company is support and assistance from the national authorities. As mentioned earlier, the Vietnamese government has been considering seriously the potential of electrifying remote areas by solar PV off-grid systems. There have been so far a number of rural electrification projects in Vietnam as indicated in the previous chapter. According to Mr. Dam Tien Thang, Director of Electricity Authority Department in Hanoi, there are several supporting methods for local and foreign companies in renewable energy field promoted by the Vietnamese government such as education, training, fairs, education class promoting awareness and knowledge, performance model projects, loans (without interest or with low interest rate) to lower the price of products and replacement spare parts, etc. Tax exemption for companies who are doing business in renewable energy field is a popular supporting method that companies receive (Dam 2013).

In addition, there is a high trend of increasing awareness of the Vietnamese people about solar PV technologies and applications not only in rural areas but also in urban areas. Purchasers of urban areas are people who want to buy solar PV off-grid system as an alternative to diesel generator during electricity-cutting-off time or people who have long outings such as camping, travelling, etc. and need portable small solar power systems to power their necessities such as cell phones, radios, etc.

### **Threats**

As a new-comer in solar PV household systems from Europe, FOSERA can encounter a number of challenges. Working culture differences are among of them. Business in Vietnam is conducted mainly through a network of contacts; therefore, it is vital to find the engaged, motivated and experienced person who has good contact network in assisting the company in early entry stages. Not all companies in Vietnam have websites and the existing websites are not very reliable in terms of information, data and communication. It's difficult to get into contact with the right responsible business partners just simply by email

exchanges. Email and phone contact of the company's director or manager might not be available on the website. There are companies who are likely to be potential business partners or competitors; however, no information if they is available yet on the Internet. Face-to-face meeting is a more common way to get into contact with the right person and get the necessary information. Business negotiations occur not only in the offices but also often in restaurants or other unofficial places. Agreements are not always signed in the form of contracts, but they can also simply by saying or words. Word of mouth is a valuable means of marketing strategies. The level of hierarchy in business is quite high, which makes the administration process is time-consuming and sometimes costly. Despite the facts that English has become more common these days in big cities, most of the people are unable or have difficulties in speaking and understanding English, which might prevent communication between the case company representative and other stakeholders.

There are barriers to the implementation of renewable energy related projects or business in Vietnam in terms of laws and finance. They can be insufficient support from the government to attract companies doing business in Vietnam, non-detailed incentive mechanisms, slow and complex administration process (Nguyen T.H 2013). The current policy and legislative framework for the development of renewable energy is inadequate to enhance the development of Vietnam's renewable energy. Mr. Tien Thang has stated that the challenge that companies have to face when entering the Vietnamese rural market is the national law and regulation (Dam 2013). The realization of relating legal documents in reality is still low or unclear. There are also certain unexpected changes in law that have not yet mentioned or updated in the official version. Financially, there is a lack of limited finance assistance for customers and project developers (Thuc, 2012). The Vietnam Electricity Group (EVN) is still the market monopoly of transmitting, purchasing and distributing of electricity. Therefore, if the company is going to cooperate with the government through state-funded rural electrification projects, it is likely for the company to cooperate with EVN branches in provinces. As stated by Mr. Nguyen The Hai (2013), business opportunity of solar PV stand-alone systems in rural areas still depends much on the price level and incentive mechanism of the government towards it.

Threat of not being accepted by the people and not winning in governmental rural electrification projects should be also taken into consideration. Other threats might be losing the key important assistant personnel as benefits from rural electrification projects are little and time-consuming, losing good images on the international market as the company has to deal with bribery and corruption in Vietnam, not gaining profits but lose money and other minimal threats.

#### 5.4 Porter's Five Forces Analysis for FOSERA

Porter's Five Forces tool is used to analyze the external environment factors that have influence on the company business activities. Five Forces are Competitive Rivalry among Existing Competitors, Threats of New Entrants, Threats of Substitute Products, Bargaining Power of Customers and Bargaining Power of Suppliers. Below is the figure illustrating Porter's Five Forces.

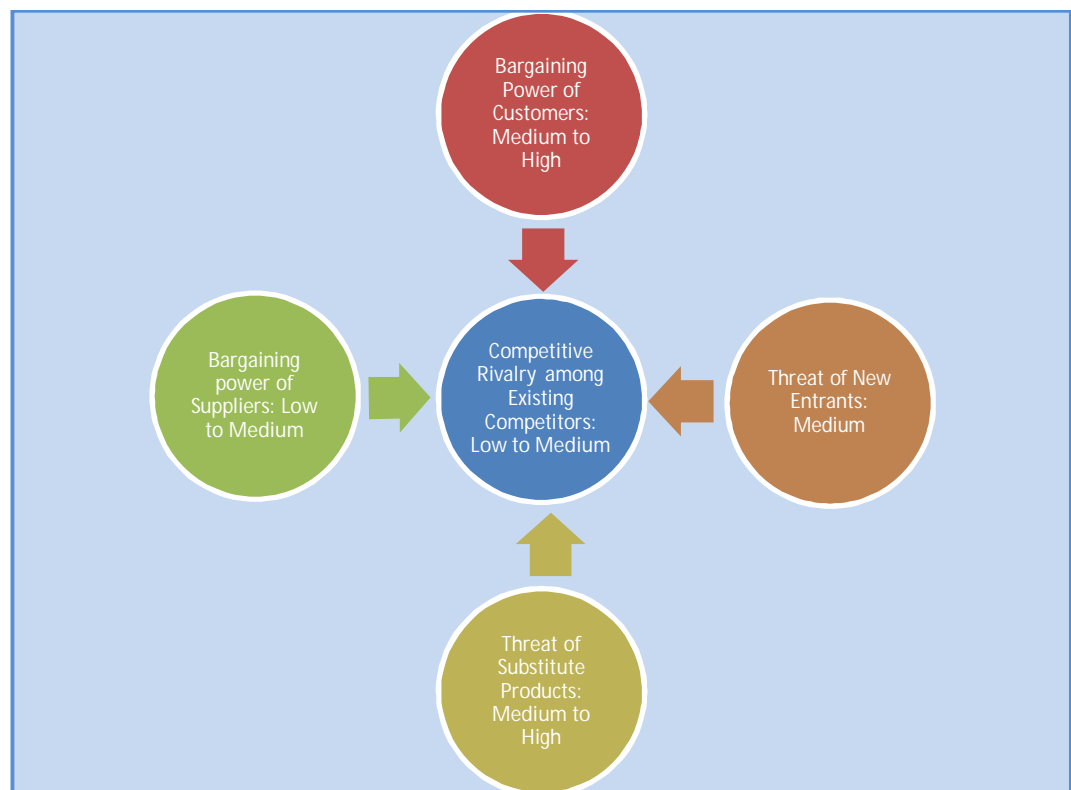

FIGURE 22. Porter's Five Forces for FOSERA

### **Competitive among existing competitors: Low to Medium**

Main competitors of FOSERA on the Vietnamese market are Redsun, Solar Bach Khoa and Selco Vietnam. Short analyses of these three companies are described below.

Redsun Energy Joint Stock Company is the first solar photovoltaic panel manufacturer in Vietnam since 2007. The company produces solar panels for residential, commercial & industrial, and power plant. The company's products are various including Solar Photovoltaic Panels (20W, 50W, 110W, 130W) for residential usage, Solar Photovoltaic Panels (180W and 190W) for commercial and industrial usage, Solar Photovoltaic Panels (220W, 270W, and 200W) for Power Plant (Redsun 2012). One of the most prominent competitive products of Redsun is Solar Lighting Kit (20W). The package includes 20W solar panel, charge controller with battery inside, 2\*2W LED Light Bulb with 5m cable, mounting frame and stand. Its applications are for farmer household lighting, camping uses, etc. Besides, Redsun has gained good reputation in Vietnam among different stakeholders as an active company with many cooperating projects with the Vietnamese government (Dinh 2013).

Solar Bach Khoa (or Bach Khoa Investment and Development of Solar Energy) is a company specializing in R&D, manufacturing and consultancy. The company's products are solar energy products such as solar PV system, solar water heater, wind energy products such as small wind turbines for battery charging, etc. One of the important product ranges is Micro-Grid Power System which is a combination of solar photovoltaic, wind with diesel generators to provide electricity in remote areas. (Bach Khoa 2012)

SELCO Vietnam Ltd. is a subsidiary of SELCO Inc. based in the USA with 100% foreign-owned capital. The company's products are Solar Home System "SHS" from small to large capacity or customized SHS based on customers' request, solar modules, LED Lamp Super Energy Saving (12VDC 7W, 9W, 11W), SELCO Charge Controllers, Genius Inverters, Solar Garden Light (type 1 and 2), Solar Floating Lamp (UFO), Solar Garden Lamps, DC Fan (12C, 15Watt), Solar

LED Lantern, etc. SELCO has had partnership with GE Energy, Kyocera, Morning Star Corporation, SMA, Solar World, Xantrex, U.S Battery, etc.

SELCO-Vietnam Ltd. was awarded the “Award for Corporate Excellence 2001” by the U.S State Department. SELCO focuses its business in rural electrification through Solar Home System for remote areas, solar energy for telecommunication, clinics, military forces who are in duties in border and utmost areas, island, solar energy for post offices, people’s committees, schools of rural villages, etc. (Selco Vietnam 2012) So far SELCO Inc. has installed over 20,000 solar home systems for families with no access to the electricity grid in India, Sri Lanka, Vietnam, etc. SELCO Vietnam promotes “Solar energy in supporting the outmost areas” with the aim of bringing solar energy to areas where there are no access to the national grid or unstable grid. The company cooperates with Vietnam Women Union (VWU) and Vietnam Bank of Agriculture and Rural Development (VBARD) to deploy the project of “Electrification the countryside with solar energy” in 15 southern provinces. SELCO Vietnam has installed over 3,653 solar home systems with total output of 262kW. SELCO Vietnam is also involved in energy programs in Vietnam such as installing solar energy for over 30 National Parks, conservation zones, over 50 army border stations and islands. The company has supplied more than 150kWp solar photovoltaic for telecom companies and rural post offices, over 500 kit of solar signaling for waterway and airway (Selco Vietnam 2012).

Besides, there are a number of potential competitors on the Vietnamese market such as Seilar Energy Vietnam Co. Ltd. (part of Seilar Energy Australia group), Minh Ha co. Ltd. (sole agent of LEONICS), Saigon Solar JSC, Vu Phong Co. Ltd. (Solar V), Chinattech JSC, VN Solar Inc., Center Point Co. Ltd., Gia Nam Corporation (Megasun), Viet Trung Technology & Trading Co. Ltd. (sales representative of Samtrix, sales agent of Schott, Kyocera, Suntech, Xantrex, SMA, etc.), etc. Though the competition level among companies in renewable energy field is still low, FOSERA is likely to deal with several competitors on the markets who offer customers with more affordable price, better customer and after-sales support, etc.

### **Threat of New Entrants: Medium**

There have been so far not so many companies in the solar energy field doing business in rural areas. As mentioned earlier in the previous part, there are a few companies who offer solar products for people living in rural areas such as Solar Bach Khoa, Redsun and SELCO Vietnam. Still, those products are not among their primary offer or focus in reaching the Vietnamese customers. In addition, most of the answers from the Questionnaire for Vietnamese authorities (2013) showed responders' pessimistic opinion about companies' interest towards doing business in remote regions. However, as the Vietnamese government is striving to achieve its goal of electrifying 100% households in Vietnam by 2020 and promoting the rural electrification campaign in various means of communication such as television, internet and website, trade fairs, there will be an increasing number of companies, both local and foreign, who show more interest to this unreached market segment. International competitors of FOSERA are also likely to enter the market if the profitability potential and chance of expanding market and image are attractive enough.

### **Threat of Substitute Products: Medium to High**

There are substitute products of other renewable energy technologies to rural electrification such as small-scale hydropower plants in provinces, power generated from biogas, concentrated solar power, diesel-solar or wind-solar home systems, solar PV charging power stations, on-grid electricity through the national power system or through other renewable energies, etc. (Questionnaire for Vietnamese authorities 2013). There are advantages and disadvantages of applying one of those mentioned renewable technologies. For example, biogas technology is still in early nascent stage. Cost for constructing hydropower plants or stretching electricity cables via national on-grid systems to rural areas is still high. Price of diesel and oil is increasing in the future. In general, solar PV off-grid home system was confirmed by several interviewees to be one of the most feasible options to electrify rural areas (Questionnaire for Vietnamese authorities 2013; Questionnaire for experts 2013).

Besides, there are several companies which have not yet established business in Vietnam but also offer renewable energy products in rural areas such as D.Light, Greenlight Planet, Barefoot, Sundaya, etc. Provided that some of those mentioned companies enter the Vietnamese market in the future, they are likely to be FOSERA's competitors.

### **Bargaining Power of Suppliers: Low to Medium**

As the products of FOSERA are designed in Germany and manufactured in Thailand and India, the power of suppliers of product components will not play an important role in the Vietnamese market. Still, the price of batteries for the solar systems and of LED lamps is expected to go down in the near future (Adelmann C. 2013). In the future, it is highly likely that there will be an increasing number of new companies who run similar business as FOSERA and are in need of solar component supply. Consequently, FOSERA's suppliers of those components may increase the manufacturing price of solar components, which lead to increasing cost for FOSERA.

There are a number of potential business partners for FOSERA such as Devi Renewable Energies, New Energy (distributor of Sunova), Viet Linh Manufacturing and Trading Electric-Electronic Co. Ltd., IC Energy Industry Co. Ltd. (member of IC Holding Vietnam), Tuan An Group (distributor of Hubbell, Nu-Lec, Wenzhou Lucheng, Solar World, Cygnus Power, Rehau, Roto Frank AG, etc.), Son Ha TCC. JSC, Bao An Corporation (distributor of Aseries solar water heaters, Apollo, Bach Khoa, Solarhart), etc. However, as those companies are also sales representatives for several brands, they have power over the company in negotiations. In some cases, those potential business partners can turn out to be potential competitors of the case company.

### **Bargaining Power of Customers: Medium to High**

Customers have power over purchasing decision of the products. There are certain challenges for the case company in selling its products to customers in Vietnam in terms of customers in rural areas as well as potential customers in urban cities.

Affordability is one of the biggest challenges for people living in rural areas that are also the main customer segment of the case company. As customers are usually from the bottom of the pyramid (BOP), they are not able to purchase the products without any financial supports from the community, from the company or from the government. There are several solutions to this financial matter, one of which can be through financial assistance of rural banks and microfinance institutions. Micro Energy Credit (MEC) is an organization that supports loans to rural banks and then microfinance institutions. The success of utilizing carbon funds can be seen in the case of MEC partners in North India selling Solar Home Lighting System to the Indian low-income customers. MEC partners has utilized the Carbon funds provided by MEC to establish customer service centers, training of after-sales service staff, training of bank staff and marketing activities (Thoumoung 2012). Another challenge is the cost of investment in marketing activities and awareness generation, after-sales customer service, maintenance program, etc. People living in remote areas have a low level of education; therefore, the company needs different approaches towards advertising the products to them. For example, cooperation with the Vietnamese government and local authorities will enable the company to advertising its products through education classes, meetings, seminars, conferences, propagandas, campaigns, etc. in local regions.

Another customer segment is people living in urban areas. They might be attracted to purchase the systems as an alternative electricity supply to prevent unexpected power shortage which often happens in Vietnam during the dry season. (Le 2009, 53) In another way, solar PV stand-alone systems are better alternatives for diesel generators during electricity cutting-off time. Purchasers can also be those who need solar stand-alone systems for long-distance travelling such as going hiking or camping. During their vacation days, they need solar stand-alone systems which can recharge their necessity devices such as cell phones, small fridges, etc. The affordability of customers becomes less important; however, customers from this segment have more purchasing power over the company as they have more choice. The quality of the products plays an important role in their decision of what to buy.



## 6 BUSINESS OPPORTUNITIES FOR THE CASE COMPANY

Suggestions of market entry mode to Vietnam are based on comparing and combining answers of Vietnamese authorities and experts in the renewable energy sector in Vietnam. The answer of Vietnamese authorities to the question “Which types of market entry modes is suitable for a company like FOSERA to enter the Vietnamese market?” in the conducted questionnaire were partnership in the form of joint-venture and cooperation with governmental and non-governmental organizations.

A similar question was applied to interview three experts in renewable energy fields and the answers were 2 out of 3 for direct import, 2 out of 3 for joint-venture and 1 for sales representative. Therefore, based on analyzing the solar energy market of Vietnam with focus on rural areas and interviewing different stakeholders, the author came up with suggestions of market entry modes for the case company to enter the Vietnamese market. The suggestions are conducted based on a timeline showing three periods of time and different market entry strategies for each period.

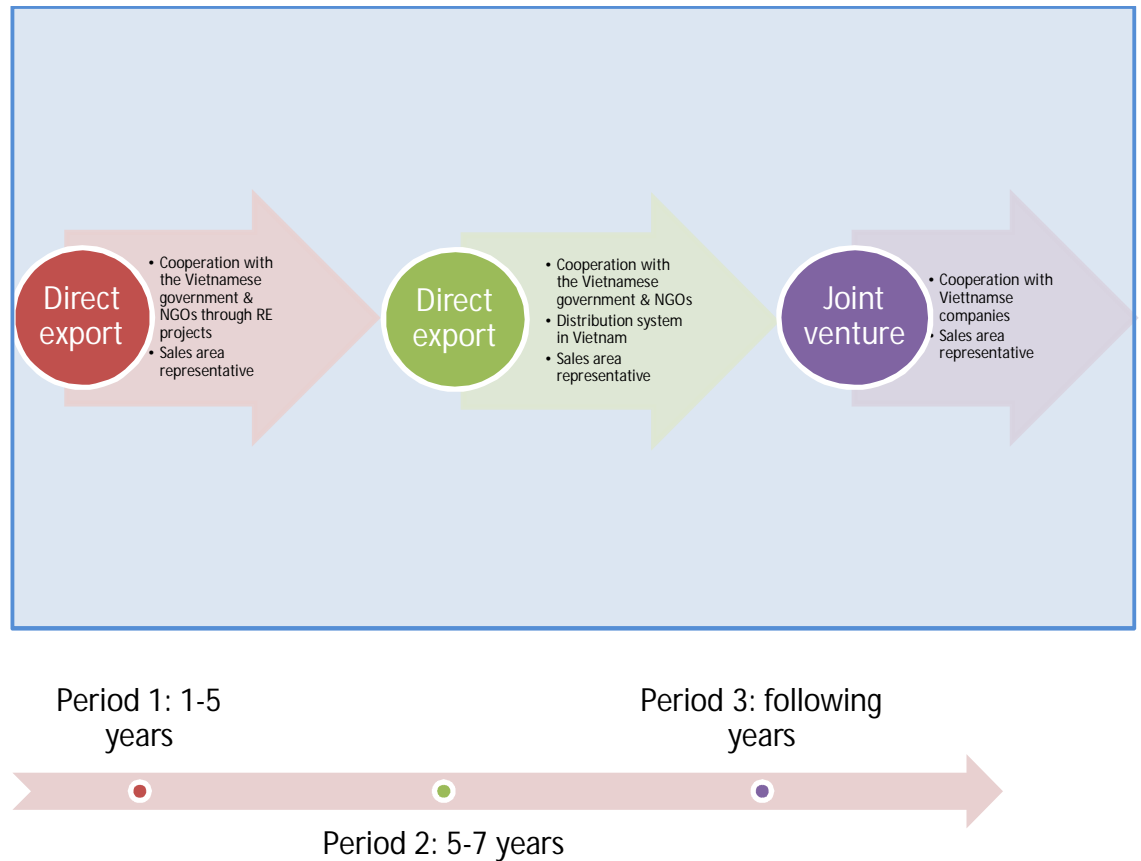

FIGURE 23. Timeline of FOSERA's market entry modes to Vietnam

As illustrated in the graph, two main market entry modes are direct export and joint-venture. Yet, assistances and operating activities are implemented differently for each market entry mode along each period of time.

#### 6.1 Period 1: Direct Export Model + Cooperation with the government and NGOs in Vietnam

During period 1 (from 1 to 5 years), direct export is implemented in cooperation with the Vietnamese government and other NGO organizations.

As the Vietnamese government has a fund for rural electrification in Vietnam to increase social well-being of the people, FOSERA can sell products through direct export to the Vietnamese government via rural electrification projects. Take the case of Solar World as an example. Solar World has established its first step in

Vietnam through rural electrification projects. As studied, the Vietnamese government is willing to help foreign companies in renewable energy field to enter the Vietnamese market. The difficulty is not in the government but in the administration system. It means that the company should be able to expect bribery during the administrative process in order to win the projects. As FOSERA is an international company with high-quality products, it is the strength and advantage of the company to win other competitors in rural electrification projects. The important issue is to find a Vietnamese expert or intermediary who is able to ease the administration process.

Another suggestion is to sell the products through rural electrification projects of NGOs. NGOs play as funding foundations which purchase FOSERA's products. NGOs can be German government. In fact, there is a rural electrification project in Vietnam funded by the German government. NGOs can be any other national governments such as the Japanese, the Swedish, the Danish government, etc. They have already involved in the rural electrification projects in Vietnam. The World Bank also has funds for Vietnam through different projects. By directly sell FOSERA's products to the Vietnamese government or NGOs through rural electrification projects, FOSERA can first establish the good image and reputation of the company in the Vietnamese market. It has a significant meaning for the company in the future because not only the Vietnamese purchasers are accustomed with the qualitative products of the company, but also the potential business partners in Vietnam are informed of FOSERA and its products.

Having a sales representative in Vietnam at the same time would assist activities for direct export. The responsibilities of a sales representative are to advertise products of the company to different stakeholders such as universities, potential business partners, organizations, etc. Besides, a sales representative is also in charge of finding information about rural electrification projects in Vietnam as well as coordinating with FOSERA in those projects.

Generally, there is a real need for renewable energy in Vietnam in the near future. As soon as FOSERA enters the Vietnamese market, the company will have more advantages over other companies who are followers. The Vietnamese renewable

market is still in nascent stage, which means there are opportunities for companies who first quickly catch the trends and invest in the Vietnamese market.

## 6.2 Period 2: Direct Export Model + Distribution Channels in Vietnam

During period 2 (from 3- 5 years), direct export together with establishing distribution channels in Vietnam are implemented. Local distributors in Vietnam can be local enterprises or local companies who are willing to distribute FOSERA's products, to advertise the products to the people in rural areas and provinces and to coordinate with local authorities. Still, it is advisable to maintain the sales representative who works as an intermediary and coordinator between distributors and the company FOSERA.

Mr. Dam believed that finding an enthusiastic Vietnamese business partner in the long term is a better strategy than cooperating with NGOs, universities or sub-contractors in the short-term for maintaining and giving loans for purchasers (Dam 2013). On the other hand, Mr. Hai considered mutual cooperation between companies with governmental organizations, NGOs and technical universities in maintaining products and offering loans solutions to purchasers is feasible because the Vietnamese laws allow and encourage universities and institutes which have facilities, equipment's, ability, knowledge and experiences to do that. (Nguyen N. H. 2013)

During this period, the case company can expand its market from rural areas to urban cities in Vietnam. The Vietnamese government has already stated in its recent publishing documents that it aims at achieving 600.000 households in rural areas electrified in a few years later. According to a recent study by DEVI Renewable, there are still almost 2 million households in Vietnam who are lacking electricity (DEVI Renewable 2011). The sales potential in urban areas can be seen in households whose living areas usually have electricity cut-off problem. They have a tendency to buy diesel generators which generate electricity during electricity-cutting time. FOSERA can create a new habit for them by advertising its products as a better solution to diesel generators. There are also potential for purchasers who want to buy products for the purpose of travelling. When they go

hiking or camping, FOSERA's products are portable and convenient for them to electrify their necessary devices such as cell phones, lamps and other necessities.

### 6.3 Period 3: Joint-Venture model

During period 3 (after 5 years), FOSERA can choose joint-venture as market entry mode to make more investments and earn more profits. Joint-venture can be through transferring of technology, building new manufacturing facilities in Vietnam and having equity as holdings in order to establish long-term presence on the Vietnamese market. The joint-venture model is well evaluated because it combines the technology and financial ability of FOSERA with practical experiences of Vietnamese companies to help the business succeed on the market (Dam 2013). Three forms of foreign investments that are accepted by the Vietnamese government according to article 4 of the Law on Foreign Investment in Vietnam are business co-operation on the basis of a business co-operation contract, joint venture enterprise and enterprise with one hundred per cent of foreign owned capital (Law on Foreign Investment 2006). If FOSERA wants to construct a project such as a new manufacturing facility in Vietnam, the company should be able to prove the source of capital and loan commitment of banks for the to-be-implemented project. Besides, it was stated that the owner of the project should have at least 30% of the total investment capital in the projects. Forms for power projects can be BOT (Build-operate-transfer), BOO (Build-Own-Operate) or other legal forms such as PPP (Public-Private Partnership) (Cooper 2012, 8).

## 7 CONCLUSION AND SUGGESTIONS FOR FURTHER RESEARCH

In this chapter the author describes main findings from the research and gives several suggestions for further research in the end of the chapter.

### 7.1 Main findings

The summary table below indicates the main findings from the study. They answer the main research question and other sub-research questions.

TABLE 6. Main findings

Research question	Research findings
What kinds of market entry modes are suitable for the case company to enter the Vietnamese rural market?	<p>Three types of market entry modes are suitable based on a suggested timeline:</p> <ul style="list-style-type: none"> <li>• Direct export, cooperation with the Vietnamese government and other NGOs</li> <li>• Direct export and distribution channel in Vietnam</li> <li>• Joint-Venture</li> <li>• Assisting activity: sales representative in Vietnam</li> </ul>
How do legislations on power and energy affect the solar energy industry in Vietnam?	<ul style="list-style-type: none"> <li>• Improved legislations on renewable energy have enhanced the development of solar energy industry in Vietnam.</li> <li>• Still, more concrete law and detailed incentives on renewable energy projects and investments are needed.</li> </ul>
What are the challenges facing foreign companies in doing business in Vietnam/ in rural areas in Vietnam?	<p>Main challenges are:</p> <ul style="list-style-type: none"> <li>• Complexity and slowness of administrative procedure</li> <li>• Lack of concrete incentives and support from the government to companies</li> <li>• Cultural differences &amp; working styles</li> </ul>

Are there any foreign companies which are currently working in solar energy sector in Vietnam?	Yes, some of them are:  SELCO Vietnam, Solar World
What should be improved to enhance the growth of renewable energy sector in Vietnam?	<ul style="list-style-type: none"> <li>• More concrete law and incentives for local and foreign companies in renewable energy field, especially for SMEs</li> <li>• Improvement in administrative procedure (more transparency, faster administrative process, more coordination among governmental institutes, etc.)</li> <li>• More provision of information and knowledge on renewable energy for the Vietnamese citizens</li> </ul>
What is the best option among renewable energy technologies for rural electrification in Vietnam?	Solar photovoltaic off-grid/stand-alone systems
Besides solar energy, which types of renewable energy are also suitable for rural electrification?	Small-scale hydropower stations

In conclusion, with the forecast of electricity shortage in the coming years, Vietnam is in need of renewable energy as an alternative reliable source of energy for the country's economic development. As solar water heaters have been becoming more popular on the Vietnamese market in urban areas, solar PV is likely to dominate the rural markets especially in remote regions where there is no access to electricity or difficulties in installing an on-grid electricity system. The Vietnamese government has been paying more attention to the economic potential of renewable energy and has been making effort to improve the law and

regulations on renewable energy, to liberalize the power market and to attract more foreign investors and companies in the field.

Local and foreign SMEs are looking forward to more effective and quick support from the government to do business in the field. New projects should not be any more funded by international or national organizations for demonstration purposes only, but they should be invested in by people who are intending to do business in the field (Le 2009, 57-59). To enhance the efficiency and effectiveness of renewable energy industry in Vietnam, more concrete law and incentives for local and foreign SMEs from the government are needed. The administrative process systems should be less complicated, more transparent and more cooperative. Besides, more campaigns, tradefairs and public events in renewable energy are expected in order to raise the citizens' awareness of the environment as well as sustainable solutions to the green and economic issues through renewable energy.

For the case of FOSERA, it's high time to enter the market. There are only a few foreign companies existing in the Vietnamese market such as SELCO Vietnam, Solar World. The number of Vietnamese companies is larger including some potential competitors such as Solar Bach Khoa, Redsun Vietnam and other SMEs. Despite certain risks, the company still has high opportunity to win the nascent power market in Vietnam.

Solar photovoltaic off-grid home systems were confirmed by several Vietnamese interviewed authorities to be one of the best options to electrifying rural areas in Vietnam provided that the company has a high commitment, passion and right strategies. Still, there are a few options of rural electrification besides solar PV off-grid home systems such as small-scale hydropower station, solar-wind stand-alone systems, etc.

Market entry mode suggestion for FOSERA is direct export and joint-venture with cooperation with the Vietnamese government as well as non-governmental organizations in Vietnam. The presence of a sales representative or intermediary who works as a coordinator and assistant between the headquarters of the company in Germany and the distribution channels in Vietnam would assist operating activities. The timeline of market entry is recommended to follow as the



solar PV energy industry in Vietnam is still in a developing phase. Therefore, it is not profitable to implement all options of market entry modes at the same time.

## 7.2 Proposals for further research

Some suggestions for further research are deeper investigation in structure and mechanism of financial support for BOP customers, thorough marketing strategies and sales for entering the rural markets, more information on coordination methods with local government and on resources for new rural electrification projects in Vietnam. Last but not least, more information and deeper market research about potential distributors and business partners in Vietnam such as their strengths and weaknesses, product features, etc. can also be further explored.

## 7.3 Validity and Reliability

This thesis has been written after careful and diligent research. The used information was collected from updated sources including books, earlier studies, articles, questionnaires, interview, email exchanges and other online sources. With a careful restructuring of the data collected, the author reassures that the thesis is itself a reliable source of information for future writers or authors. However, it should be noted that the business landscape is evolutionary which might render some useful information to become obsolete over time. The empirical study was conducted based only on interview and questionnaires with different stakeholders such as Vietnamese authorities, companies and experts in renewable energy without taking a survey with Vietnamese citizens living in rural areas; therefore, the study result lacks valuable contributions from the consumer point of view.

## 8 SUMMARY

Vietnam is in need of renewable energy in the future. The Vietnamese government has increasingly been supporting the development of renewable energies in Vietnam recently. The upcoming Law of Renewable Energy and changes in legal framework in the near future will provide more opportunities for local and foreign companies including large as well as small and medium-size companies to enter the Vietnamese market. As the Vietnamese government is committed to electrify 100% of Vietnamese households by 2020, the governmental authorities are open to any cost-effective and reliable solutions from renewable energy to reach their target. Among a few options of rural electrification, a PV off-grid system has demonstrated to be a feasible solution in Vietnam.

Now it's the right time for FOSERA to plan suitable market entry and business strategies in order to enter the Vietnamese market. Being a pioneer of solar PV off-grid home systems from Germany gives the company both advantages and disadvantages. As Vietnam's political issues and economic development path are different from those of other developing countries, it is necessary not to stereotype the market entry modes applied to those countries. By thorough analysis of the Vietnamese external environment together with well-planned market entry strategies and flexible business models, FOSERA can reach its goal of entering this potential market by gaining firstly the trust of the government, the awareness and acceptance of potential customers and other stakeholders. Despite estimated challenges upon entering the new unfamiliar market, the author has high confidence in the success of the case company in the Vietnamese market. The urgent question is when to enter and who the company is going to contact in order to invade this potential market.

## REFERENCES

### Published References

- Bryman Alan, Bell Emma (2007). *Business Research Methods* ( 2<sup>nd</sup> ed.). Oxford University Press.
- Capon Claire. (2009). *Understanding the Business Environment* (3rd ed.). Edinburgh, England: Pearson Education Limited.
- Czinkota Michael, I. R. (2009). *International Business*. Barcelona, Spain: Grafos SA.
- Pelle, S. (2007). *Understanding Emerging Markets-Building Business BRIC by BRICK*. New Delhi, New Delhi, India: Tejeshwar Singh for Response Books.
- Porter, M. E. (2008). *On Competition*. Boston, The United States of America: Harvard Business School Publishing.
- Sherlock, J. R. (2011). *International Trade-An Essential Guide to the Principles and Practce of Export*. London Philadelphia New Delhi: Kogan Limited.
- Travis, T. (2007). *Doing Business Anywhere-The Essential Guide to Going Global*. New Jersey, The United States: John Wiley & Sons, Inc.
- Wall Stuart & Rees Bronwen. (2001). *Introduction to International Business* (1st ed.). Edinburg, England: Pearson Education Limited.

### Electronic references

- Adelmann, P. (2012). *Wireless Power*. Retrieved November 21st, 2012, from DEVI Renewable Energies: <http://devi-renewable.com/2011/06/20/pico-solar-pv-introduction/>
- Brookings. (2012). *Vietnam nhieu dan ngheo gan nhat khu vuc*. Retrieved January, 2013, from BBC:

[http://www.bbc.co.uk/vietnamese/business/2012/09/120907\\_vn\\_poverty.shtml](http://www.bbc.co.uk/vietnamese/business/2012/09/120907_vn_poverty.shtml)

Brown, M. (2011, September 1st). *Vietnam Power Development Plan for the 2011-2020 Period. Legal Update Infrastructure* . Retrieved November 21st, 2012, from Mayer Brown JSM:  
<http://www.mayerbrown.com/files/Publication/7eb02f45-1783-4f14-8565-bf5120e1ea08/Presentation/PublicationAttachment/5dcbbea1-2d9f-42ae-8cbd-dab97456c4c5/11556.pdf>

Businessballs. (2012). *SWOT analysis method and examples, with free SWOT template*. Retrieved December 9th, 2012, from  
<http://www.businessballs.com/swotanalysisfreetemplate.htm>

Business Dictionary. (2013). *Direct exporting*. Retrieved Jan 18th, 2013, from Business Dictionary: <http://www.businessdictionary.com/definition/direct-exporting.html>

Business Dictionary. (2013). *Risk*. Retrieved Jan 19, 2013, from Business Dictionary: <http://www.businessdictionary.com/definition/risk.html>

Businessmate. (2010). *What is the PESTEL Framework?*. Retrieved February 2nd, 2013, from BusinessMate.Org:  
<http://www.businessmate.org/Article.php?ArtikelId=16>

Chinatech. (2013). Retrieved Jan 13, 2013, from China Technology JSC.:  
[www.chinatech.com.vn](http://www.chinatech.com.vn)

Cooper, G. (2012). *Vietnam's Renewable Energy Legal Environment-Getting projects done today and tomorrow*. Retrieved November 29th, 2012, from ENEREXPO Vietnam 2012

cp-lights. (2013). Retrieved Jan 13, 2013, from Centre Point Co. Ltd.: [www.cp-lights.com](http://www.cp-lights.com)

Dan Tri (2013). *Khoi cong dai Du an nha may pin mat troi hon 6.000 ty tai Hue*. Retrieved Jan 10th, 2013, from Dan Tri News: <http://dantri.com.vn/kinh->

doanh/khoi-cong-dai-du-an-nha-may-pin-mat-troi-hon-6000-ty-tai-hue-682564.htm

- Dang, D. T. (2012). *Solar PV Technology in Vietnam-Application status, problems and future*. Retrieved November 29th, 2012, from ENEREXPO 2012
- DEVI-Renewable. (2011). *Quang Nam co cong ty san xuat pin mat troi*. Retrieved Jan 10th, 2012, from DEVI Renewable Energies: <http://devi-renewable.com/2011/03/26/cong-ty-solar-thin-film-o-quang-nam/>
- DEVI-Renewable. (2011, March 19th). *Solar energy projects in Vietnam*. Retrieved Jan 10th, 2013, from DEVI Renewable Energies: <http://devi-renewable.com/2011/03/19/solar-pv-vietnam-overview/>
- Embassy of the Socialist Republic of Vietnam in the United States of America. (2013). *Vietnam: Constitution and Political System*. Retrieved Jan 19, 2013, from <http://vietnamembassy-usa.org/vietnam/politics>
- EPIA. (2012). *Global Market Outlook 2012*. Verona, SolarExpo 2012. Retrieved November 10th, 2012, from European Photovoltaic Industry Association: [http://www.epia.org/fileadmin/user\\_upload/Publications/EPIA-SolarExpo-9May-GMO.pdf](http://www.epia.org/fileadmin/user_upload/Publications/EPIA-SolarExpo-9May-GMO.pdf)
- FOSERA. (2012). Retrieved December 2nd, 2012, from [http://www.foseera.com/contactus\\_en.php](http://www.foseera.com/contactus_en.php)
- Global Edge. (2013). *Vietnam: Economy*. Retrieved February 4<sup>th</sup> 2012, from Michigan State University: <http://globaledge.msu.edu/countries/vietnam/economy>
- Global Intelligence Alliance-GIA (2012). *Business Perspectives on Emerging Markets 2012-2017-Findings from global survey*. Retrieved November 15th, 2012, from Global Intelligence Alliance: <http://ww.slideshare.net/GIAGroup/business-perspectives-on-emerging-markets-20122017>

- Huong, P. T. (2012). *Vietnam Policies for renewable energy development*. Retrieved Jan 21st, 2013, from Centre for Science and Environment: [http://cseindia.org/challenge\\_balance/readings/Huong\\_presentation.pdf](http://cseindia.org/challenge_balance/readings/Huong_presentation.pdf)
- Indexmundi. (2012). *Vietnam: International Organization Participation*. Retrieved February 4<sup>th</sup>, 2013, from: [http://www.indexmundi.com/vietnam/international\\_organization\\_participation.html](http://www.indexmundi.com/vietnam/international_organization_participation.html)
- iGrad. (2012). *How to use S.W.O.T Analysis for Investments*. Retrieved December 9th, 2012, from [www.igrad.com](http://www.igrad.com): <http://www.igrad.com/articles/how-to-use-swot-analysis-for-investments>
- Info Entrepreneurs. (2013). *Joint Ventures and Partnering*. Retrieved Jan 22nd, 2013, from Info Entrepreneurs: <http://www.infoentrepreneurs.org/en/guides/joint-ventures-and-partnering/>
- Investment and Income. (2012). *Foreign Direct Investments*. Retrieved Jan 22nd, 2013, from <http://www.investmentsandincome.com/investments/foreign-direct-investments.html>
- Investopedia. (2013). *Acquisition*. Retrieved Jan 21st, 2013, from Investopedia: <http://www.investopedia.com/terms/a/acquisition.asp#axzz2IayBokmN>
- Investopedia. (2013). *Joint Venture*. Retrieved Jan 21st, 2013, from [Investorguide.com: http://www.investopedia.com/terms/j/jointventure.asp#axzz2IayBokmN](http://www.investopedia.com/terms/j/jointventure.asp#axzz2IayBokmN)
- Investorguide. (2013). *Foreign Direct Investment*. Retrieved Jan 18th, 2013, from <http://www.investorguide.com/definition/foreign-direct-investment.html>
- Le, C. H. Prof. (2009). *Solar Energy and Solar Photovoltaics in Vietnam*. Berlin. Retrieved December 3rd, 2012, from Berlin.de: <http://www.berlin.de/apforum/apw/apw2009/presentations.html#>
- Markets, F. (2012). *Capital Assessment for Clean Energy Distribution*. Retrieved Jan 12, 2013, from Frontier Markets:

<http://www.scribd.com/doc/117085623/Capital-assessment-for-clean-energy-distribution>

maynangluong. (2013). Retrieved Jan 13, 2013, from Bao An Corporation:  
maynangluong.net

megasun. (2013). Retrieved Jan 13, 2013, from Gia Nam Corporation:  
www.megasun.com.vn

Ministry of Industry and Trade. (2010). *Laws on energy efficiency and conservation takes effect*. Retrieved Jan 19, 2013, from National Energy Efficiency Programme-Ministry of Industry and Trade:  
<http://tietkiemnangluong.com.vn/en/activity-news/law-on-energy-efficiency-and-conservation-takes-effect-31003-8805.html>

Mondaq 2011. *Vietnam: Vietnam Power Development Plan for the 2011-2020 Period*. (2011). Retrieved Jan 20th, 2013, from  
<http://www.mondaq.com/x/144632/Renewables/Vietnam+Power+Development+Plan+for+the+20112020+Period>

nangluongmatroi. (2013.). Retrieved Jan 13, 2013, from Vinh Phat Technology Development JSC.: [www.nangluongmattroi.com.vn](http://www.nangluongmattroi.com.vn)

Nangluongmoi. (2013.). Retrieved Jan 13, 2013, from SOTA JSC.:  
<http://nangluongmoi.com.vn/>

National Assembly- Socialist Republic of Vietnam (2006). *Law on Foreign Investment in Vietnam*. Retrieved November 15th, 2012, from Government Web Portal:  
<http://www.chinhphu.vn/portal/page/portal/English/legaldocuments/Policies?categoryId=886&articleId=10001394>

Nguyen, D. C. (2012, May 2nd). Retrieved November 27th, 2012, from Institute of Energy: <http://www.ievn.com.vn/en/index.php/hoat-dong-cua->

vien/nang-luong-tai-tao/88-overview-on-current-and-trend-of-renewable-energy-market-in-vietnam-

Nguyen, T. (2011, December 13rd). *Vietnam plans bright future for solar energy.*

Retrieved November 15th, 2012, from Dan Tri News:

<http://www.dtinews.vn/en/news/018/19819/vietnam-plans-bright-future-for-solar-energy.html>

Mind Tools. (2012). *Porter's Five Forces: Assessing the Balance of Power in a Business Situation.* Retrieved December 10th, 2012, from

[http://www.mindtools.com/pages/article/newTMC\\_08.htm](http://www.mindtools.com/pages/article/newTMC_08.htm)

OANDA. (2013, Jan 17). Retrieved Jan 17<sup>th</sup>, from OANDA:

<http://www.oanda.com/currency/converter/>

Pestel Analysis. (2012). *Pestel Analysis.* Retrieved December 9th, 2012, from

<http://pestel-analysis.com/>

Quick MBA. (2012). *Porter's Five Forces: A Model for industry analysis.*

Retrieved December 10th, 2012, from

<http://www.quickmba.com/strategy/porter.shtml>

Redsun. (2012). Retrieved December 1st, 2012, from Redsun Vietnam:

<http://redsun-vn.com/>

Reiche Kilian, A. C. (2000). *Expanding Electricity Access to Remote Areas: Off-Grid Rural Electrification in Developing Countries.* World Power 2000.

Retrieved November 12th, 2012, from World Bank:

[http://w.martinot.info/Reiche\\_et\\_al\\_WP2000.pdf](http://w.martinot.info/Reiche_et_al_WP2000.pdf)

Reiche Kilian, Roman Grüner, Benjamin Attigah, Carsten Hellpap and Anna Brüderle. (May 2010). *What difference can a PicoPV system make? Early findings on small Photovoltaic systems-an engineering low-cost energy technology for developing countries.* Retrieved November 10th, 2012, from Deutsche

Gesellschaft für Technische Zusammenarbeit GmbH (GTZ):

[www.lightingafrica.org/component/.../94-pico-pv-lighting-systems-gtz.html](http://www.lightingafrica.org/component/.../94-pico-pv-lighting-systems-gtz.html)



- REN21. (2012). *Renewables 2012-Global Status Report*. Renewable Energy Network for the 21st Century. Retrieved November 12nd, 2012, from <http://www.map.ren21.net/GSR/GSR2012.pdf>
- Renewable Energy Network for the 21<sup>st</sup> Century-REN21 (2012). *Renewables 2012-Global Status Report*. Retrieved November 12nd, 2012, from REN21 : <http://www.map.ren21.net/GSR/GSR2012.pdf>
- Renewable Energy World. (2012). *Types of Solar Energy*. Retrieved November 15th, 2012, from <http://www.renewableenergyworld.com/rea/tech/solar-energy>
- Schneider Electric. ( 2011). Retrieved November 12nd, 2012, from <http://www.schneider-electric.com/site/home/index.cfm/vn/>
- Selco Vietnam. (2012). Retrieved December 1st, 2012, from Selco Vietnam: <http://selco-vietnam.com.vn/index.php?Module=Content&Action=view&id=21&Itemid=30>
- Solar Electric Light Fund-SELF. (2012). *Vietnam: History*. Retrieved November 15th, 2012, from SELF: <http://self.org/archive-vietnam/>
- Solar Bach Khoa. (2012). *Bach Khoa Investment and Development of Solar Energy Corporation*. Retrieved December 1st, 2012, from Bach Khoa Investment and Development of Solar Energy Corporation: [http://en.bk-idse.com/index.php?option=com\\_contact&view=contact&id=1&Itemid=76](http://en.bk-idse.com/index.php?option=com_contact&view=contact&id=1&Itemid=76)
- Solarpower. (2013.). Retrieved Jan 13, 2013, from [www.solarpower.vn](http://www.solarpower.vn)
- Sonhatcc. (2013). Retrieved Jan 13, 2013, from <http://www.sonhatcc.com/>
- Source Guides. (2012). *Solar Energy Businesses in Vietnam*. Retrieved December 1st, 2012, from Source Guides:

<http://energy.sourceguides.com/businesses/byP/solar/byGeo/byC/Vietnam/Vietnam.shtml>

The Community Tool Box. (2013). *SWOT Analysis: Strengths, Weaknesses, Opportunities, and Threats*. Retrieved February 3<sup>rd</sup>, 2013, from [http://ctb.ku.edu/en/tablecontents/sub\\_section\\_main\\_1049.aspx](http://ctb.ku.edu/en/tablecontents/sub_section_main_1049.aspx)

The President of the Socialist Republic of Vietnam (2004). *Law on forest protection and development in Vietnam (No. 29/2004/QH11) (2004)*. Retrieved December 21st, 2013, from [http://www.theredddesk.org/sites/default/files/law\\_on\\_forest\\_protection\\_and\\_development\\_-\\_vietnam\\_2.pdf](http://www.theredddesk.org/sites/default/files/law_on_forest_protection_and_development_-_vietnam_2.pdf)

The President of the Socialist Republic of Vietnam (2005). *Law on Environmental Protection (No. 52/2005/QH11)*. Retrieved Jan 19, 2013, from [http://www.vertic.org/media/National%20Legislation/Vietnam/VN\\_Law\\_on\\_Environmental\\_Protection.pdf](http://www.vertic.org/media/National%20Legislation/Vietnam/VN_Law_on_Environmental_Protection.pdf)

The Prime Minister. (2007, December 27). *Decision No.1855/QD-TTg approving Vietnam's National Energy Development Strategy up to 2020, with 2050 vision*. Retrieved January 10th, 2013, from <http://www.asiabiomass.jp/biofuelDB/vietnam/pdf/Decision%20No.%201855.pdf>

The State Bank of Vietnam. (2012). *Exchange rate quotation*. Retrieved November 15th, 2012, from the State Bank of Vietnam: [http://www.sbv.gov.vn/wps/portal/!ut/p/c4/04\\_SB8K8xLLM9MSSzPy8xBz9CP0os3gDFxNLCzdTEwN\\_Fy9TA09\\_42AjXwtLY\\_dAU\\_2CbEdFAKJnwns!/](http://www.sbv.gov.vn/wps/portal/!ut/p/c4/04_SB8K8xLLM9MSSzPy8xBz9CP0os3gDFxNLCzdTEwN_Fy9TA09_42AjXwtLY_dAU_2CbEdFAKJnwns!/)

The World Bank. (2012). *Vietnam*. Retrieved November 12th, 2012, from the World Bank Data: <http://data.worldbank.org/country/vietnam>

The World Bank. (2013). *Vietnam Overview*. Retrieved February 4<sup>th</sup>, 2013, from the World Bank Data:

<http://www.worldbank.org/en/country/vietnam/overview>

The World Bank. (2013). *Taking Stock-An Update on Vietnam's Recent Economic Developments*. Retrieved on February 4<sup>th</sup> 2013, from the World Bank: [http://www-](http://www-wds.worldbank.org/external/default/WDSContentServer/WDSP/IB/2012/12/13/000333037_20121213003404/Rendered/PDF/NonAsciiFileName0.pdf)

[wds.worldbank.org/external/default/WDSContentServer/WDSP/IB/2012/12/13/000333037\\_20121213003404/Rendered/PDF/NonAsciiFileName0.pdf](http://www-wds.worldbank.org/external/default/WDSContentServer/WDSP/IB/2012/12/13/000333037_20121213003404/Rendered/PDF/NonAsciiFileName0.pdf)

The World Factbook. (2012, November 6th). *Vietnam*. Retrieved November 11st, 2012, from the World Factbook:

<https://www.cia.gov/library/publications/the-world-factbook/geos/vm.html>

Thoumoung, A. (2012). *How to leverage carbon financing towards scaling up solar off-grid clean energy programs*. Micro Energy Credits. Retrieved Jan 12, 2012, from International Solar Energy Society: [http://www.ises-online.de/fileadmin/user\\_upload/PDF/Thoumoung\\_MEC.pdf](http://www.ises-online.de/fileadmin/user_upload/PDF/Thoumoung_MEC.pdf)

Thuc, T. (n.d.). *Current Status of Energy in Vietnam*. Retrieved November 22nd, 2012, from Japan Science and Technology Agency:

[http://www.jst.go.jp/astf/document2/en\\_23doc.pdf](http://www.jst.go.jp/astf/document2/en_23doc.pdf)

Trading Economics. (2013). *Vietnam GDP Growth Rate*. Retrieved February 4<sup>th</sup>, 2013, from <http://www.tradingeconomics.com/vietnam/gdp-growth>

Trinh, Q. D. (2009). *Photovoltaic technology and solar energy development in Vietnam*. Retrieved November 11st, 2012, from Tech Monitor(Nov-Dec 2009): [http://www.techmonitor.net/tm/images/6/63/09nov\\_dec\\_sf3.pdf](http://www.techmonitor.net/tm/images/6/63/09nov_dec_sf3.pdf)

Tuong, D. D. (2012). *Lastest Technologies for Harnessing Vietnam Solar Power*. Retrieved Dec 7th, 2012, from Vietnam: Power Industry Conference, Ho Chi Minh City

- Tuoitrenews. (2012). *Vietnam officially announces Law of the Sea*. Retrieved Jan 21st, 2013, from Tuoitre News:  
<http://tuoitrenews.vn/cmlink/tuoitrenews/politics/vietnam-officially-announces-law-of-the-sea-1.79934>
- US. Department of Energy, Energy Efficiency and Renewable Energy (2010). *2010 Solar Technologies Market Report*. Retrieved Dec 7th, 2012
- Usolar. (2013.). *Usolar*. Retrieved Jan 13, 2013, from [www.usolar.vn](http://www.usolar.vn)
- Vietnam Environment Protection Fund. (2012). *Vietnam Environment Protection Fund with clean development mechanism (CDM) and CDM projects in Vietnam*. Retrieved November 27th, 2012, from Ministry of Natural Resources and Environment
- Vietnam Laws. (2006). *Vietnam Legal Update*. Retrieved Jan 21st, 2013, from Vietnam Laws: [http://www.vietnamlaws.com/vlu/aug\\_2006.pdf](http://www.vietnamlaws.com/vlu/aug_2006.pdf)
- Vietnam, S. R. (2006). *Customs Law*. Retrieved November 15th, 2012, from Socialist Republic of Vietnam -Government Web Portal:  
<http://www.chinhphu.vn/portal/page/portal/English/legaldocuments/Policies?categoryId=886&articleId=10001407>
- Vuong, Q. A., & Tran, D. N. (2012, May 28th). *Vietnam: Investment Incentives for Solar and Wind Energy projects in Vietnam*. Retrieved December 4th, 2012, from Mondag:  
<http://www.mondaq.com/x/179290/Renewables/Investment+Incentives+for+Solar>
- Wikipedia. (2012). *SWOT analysis*. Retrieved December 9th, 2012, from Wikipedia: [http://en.wikipedia.org/wiki/SWOT\\_analysis](http://en.wikipedia.org/wiki/SWOT_analysis)
- Wikipedia. (2012). *Foreign Market Entry Modes*. Retrieved Jan 21st, 2013, from Wikipedia:  
[http://en.wikipedia.org/wiki/Foreign\\_market\\_entry\\_modes#Wholly\\_owned\\_subsidaries\\_.28WOS.29](http://en.wikipedia.org/wiki/Foreign_market_entry_modes#Wholly_owned_subsidaries_.28WOS.29)

### **Email exchange**

Adelmann, C. (2012). *Fosera Pico-Solar-Home-Systems-High Quality Solution for Rural Electrification*. BSW-Solar-Special Exhibition Rural Electrification. Retrieved November 21st, 2012, from email exchange with Ms. Catherine Adelmann

Adelmann, C. (2012). *FOSERA's product price list*. Retrieved November, 2012, from email exchange with Ms. Catherine Adelmann

### **Interview**

1. Dr. Petri Konttinen, Business Development Manager of Aurubis Finland, interviewed by author, 12.12.2012
2. Mrs. Maarit Virtanen, Connect Project Manager, interviewed by author, 12.12.2012
3. Mr. Bui Thien Toan, Business Development Manager of Aschoff Solar Vietnam, interviewed by author, 17.1.2013
4. Dinh Ngoc Quang Ph.D, Institute of Energy, Power System Development Department, Ministry of Industry and Trade, interviewed by author, 17.1.2013
5. Ms. Catherine Adelmann, General Manager of FOSERA Co. Ltd, interviewed by author, 18.1.2013

### **Participants in the interview questionnaires**

1. Mr. Nguyen Ninh Hai, Deputy Director of New and Renewable Energy Department, General Directorate of Energy, Ministry of Industry and Trade

2. Mr. Nguyen The Huu, Deputy Director, Planning and Demand Supply Balance Department, Electricity regulatory authority of Vietnam, Ministry of Industry and Trade
3. Mr. Do Duc Tuong, Managing Director of DEVI Renewable Energies
4. Mr. Dam Tien Thang, Director of Electricity Management, Hanoi Department of Industry and Trade
5. Mr. Nguyen Lam, expert in carbon and renewable energy, Blue World Carbon
6. Mr. Hung Thanh Ph.D, expert in biomass and biodiesel, Yamanishi University

## APPENDICES

## Appendix I: Online questionnaire for experts in renewable energy sector in Vietnam

## Questionnaire for experts in renewable energy sector in Vietnam

**1. General information**Name  
\_\_\_\_\_Last name  
\_\_\_\_\_Company/ Organization  
\_\_\_\_\_Department  
\_\_\_\_\_Current position  
\_\_\_\_\_Field of expertise  
\_\_\_\_\_Company/Organization location  
\_\_\_\_\_Email address  
\_\_\_\_\_Phone  
\_\_\_\_\_

**2. In your opinion, is the application of solar energy an effective and feasible solution to the shortage of electricity in Vietnam?**

 Yes No

**3. What is your evaluation on the application potentiality of solar photovoltaic (PV) technology in the rural electrification in Vietnam?**

 High potential Medium potential Low potential Not at all potential

**4.** Are there any financial supports for people in rural areas in purchasing products from renewable energy in general and solar energy in particular?

- Yes. Could you please name some of them?  
 No.  
 I don't know.

**5.** Could you please name some solar energy companies in Vietnam?

---

---

---

**6.** Among those mentioned companies, which ones have already had position in rural electrification in Vietnam?

---

---

---

**7.** What is your evaluation of current competition in solar energy field in Vietnam?

- High competition  
 Medium competition  
 Low competition  
 No competition

**8.** What is your evaluation of different market entry modes to rural electrification using solar photovoltaic technology?

- Direct import. Why?  
 Join Venture. Why?  
 Sales representative. Why?  
 Franchising. Why?  
 Others, which ones?

**9.** What is the rate of electricity shortage in rural areas in Vietnam?

- 100%  
 80%-100%  
 60%-80%  
 40%-60%  
 20%-40%  
 0%-20%



**10. What are the other feasible solutions to rural electrification?**

- Wind energy. Why?
- Solar concentrated energy. Why?
- Biomass. Why?
- Biogas. Why?
- Others, which?

**11. Do you think that stand-alone solar photovoltaic (PV) system is an effective and feasible solution to rural electrification?**

- Yes. Could you please explain shortly?
- No. Could you please explain shortly?
- I don't know.

**12. Do you think that off-grid solar systems will be overcome by on-grid electricity system in rural electrification in the future?**

- Yes. Could you please explain shortly?
- No. Could you please explain shortly?
- It depends. Could you please explain shortly?

**13. Do you think that there is also a high potential for stand-alone solar photovoltaic (PV) systems in urban areas?**

- Yes.
- No
- It depends. Why?

**14. What is your evaluation on the sales of solar energy products in Vietnam in the future?**

- Remarkably increase
- Relatively increase
- Slightly increase
- Not at all increase
- Decrease

**15. Could you please give shortly your evaluation on the affordability of Vietnamese customers towards solar products in the future?**

---

---

---

**16.** Which forms of support do companies in renewable energy sector receive from government?

- Tax exemption
- Tax reduction
- Feed-in-tariff
- Others, which?

**17.** Do you know any incentives offered by the Vietnamese government for small and medium-sized companies (both local and foreign) in renewable energy sector in Vietnam? If yes, could you please name some of them?

---



---



---

**18.** What is your evaluation of current practicability of energy legislation in Vietnam?

- High practicable
- Average practicable
- Low practicable
- Not at all practicable

**19.** What is your evaluation of future changes in law and legislation in renewable energy sector in Vietnam?

- Lots of changes. Which changes?
- Certain changes. Which changes
- Changes to some extent. Which changes?
- No changes at all

**20.** Are you satisfied with the questionnaire? Could you please explain the reasons for your answer?

---



---



---

**21.** Could you please give some of your suggestion for further changes or improvement of the questionnaire in the future?

---



---



---

**22.** Could you please summarize in one sentence your view on the business potential of renewable energy in general and solar energy in particular in Vietnam in the future? Thank you very much for your interest and your participation!

<hr/> <hr/> <hr/>
-------------------

**Appendix II: Online questionnaire for Vietnamese authorities in energy and renewable energy sector**

Questionnaire for Vietnamese authorities in renewable energy sector

**1. General information**

Title

---

First name

---

Last name

---

Name of company/organization

---

Department

---

Current working position

---

Field of expertise

---

Location of working place

---

Website of company/organization

---

Email address

---

**2. Do you think that the Vietnamese government will support more local and foreign investors in solar energy field in the future?**

Yes

No

Depends on the type of business or investments. Can you specify?

**3. What is your evaluation of the role of the Vietnamese government and non-governmental organizations (NGOs) in rural electrification in Vietnam?**

- Very important
- Important
- To some extent
- Not at all important

**4.** Could you please name different kinds of supports given by the Vietnamese government and non-governmental organizations (NGOs) to people living in remote areas in recent renewable energy projects?

---

---

---

**5.** What is your evaluation of solar energy potential in Vietnam?

- High potential
- Medium potential
- Low potential
- Not at all potential

**6.** What is your evaluation of the level of rural electrification in Vietnam?

- High level. At which percent?
- Medium level. At which percent?
- Low level. At which percent?
- Very low level. At which percent?
- I don't know.

**7.** What is your evaluation of companies' interest toward business opportunities in rural Vietnamese market?

- High interest
- Medium interest
- Low interest
- Not at all interest

**8.** Are there any solar projects in rural electrification in Vietnam recently?

- Yes. Please name some of them.
- No.
- I don't know.

**9.** What is your evaluation on the relations between unemployment rate and potential of

job creation in rural areas through solar projects?

- Strongly related
- Related to some extent
- Not at all related

**10.** What is your evaluation on the electrification differences between rural areas and urban areas in Vietnam?

- Very different. At which rate?
- Different. At which rate?
- To some extent. At which rate?
- Not at all different

**11.** What is your evaluation on rural electrification through on-grid systems and standalone (off-grid) systems in Vietnam?

---



---



---

**12.** What are the challenges for rural electrification in Vietnam? Could you please name some challenges companies faced when entering the Vietnamese market?

---



---



---

**13.** From your point of view, is a stand-alone solar photovoltaic (PV) system an effective and feasible solution to rural electrification in Vietnam? Could you please explain your answer shortly?

---



---



---

**14.** Which one is more popular in Vietnam?

- Solar photovoltaic
- Solar concentrated
- Other forms of solar technology, please specify
- I don't know

**15.** Which source of renewable energy will suite best for rural electrification?

- Wind energy
- Biomass
- Biogas

Others, which

**16.** What is your evaluation of the reality of Master Plan VII towards the development of renewable energy in Vietnam?

- Applied
- Applied to some extent
- Not yet applied

**17.** Which form of incentives do companies in renewable energy field receive from the government?

- Tax exemption
- Tax reduction
- Feed-in-tariff
- Other, please specify

**18.** Will there be any incentives for small and medium companies in renewable energy field in Vietnam? If yes, could you please name some of them?

---



---



---

FOSERA is an international company originally from Germany that sells stand-alone solar photovoltaic products such as solar Pico systems, solar PV home systems, solar lamps, etc.

**19.** In your opinion, which form of market entry is suitable for a foreign company in solar sector like FOSERA to enter the Vietnamese market?

- Joint-Venture. Why?
- Sales representative. Why?
- Direct import. Why?
- Cooperation with NGOs and organizations. Why?

**20.** Is it possible for companies to cooperate with non-governmental organizations (NGOs) and universities in product maintenance and financial solution to customers? Could you please explain shortly your answer?

---



---



---

**21.** Are you satisfied with the questionnaire?

- Yes
- No, please explain

To some extent, please explain

**22.** Could you please give some of your suggestions for further changes or improvement of the questionnaire? Thank you very much for your interest and your participation!

---



---



---

### Appendix III: Online questionnaire for companies in solar energy field in Vietnam

#### Questionnaire for companies in solar energy sector in Vietnam

##### 1. General information

Name of the company

---

Headquarter address

---

Branch address

---

Website

---

Phone

---

Email address

---

##### 2. What is your company's field of business?

- Solar photovoltaic  
 Solar concentrated

##### 3. What are your company's locations in the Vietnamese market?

- South of Vietnam  
 North of Vietnam  
 Central of Vietnam

- Highland
- Other regions of Vietnam. Where?

**4. What are the international markets of your company?**

- Asia
- Europe
- North America
- Latin America
- Africa
- Other regions. Which?

**5. What are the strengths of your company in the field?**

- Price
- Product Quality
- Market knowledge
- Networking
- Others. Which ones?

**6. What are the weaknesses of your company in the field?**

- Price
- Product Quality
- Market knowledge
- Supply chain management
- Networking
- Others. Which ones?

**7. Do you think that Vietnam has a potential market for the development of renewable energy business in general and solar energy business in particular?**

- Yes, why?
- No, why?
- I don't know.

**8. Which form of market entry mode has your company been using to enter the Vietnamese market?**

- Direct export



- Sales representative
- Joint Venture
- Franchising
- Subsidiary
- Others, which ones?

**9.** Could you please name some of your competitors in the market domestically and internationally?

---



---



---

**10.** What is your evaluation of the importance of mutual cooperation with other companies?

- Very important
- Important
- Important to some extent
- Not at all important

FOSERA is an international company originally from Germany that sells stand-alone solar products such as solar Pico systems, solar home systems, and solar lamps and so on.

**11.** Are you willing to cooperate with a foreign company like FOSERA in the Vietnamese market? Please explain reasons for your answer.

---



---



---

**12.** Which forms of business partnership would you prefer in cooperation with a company like FOSERA? Please explain your answer.

---



---



---

**13.** Are your products

- 100% manufactured in Vietnam?
- Partly manufactured in Vietnam, partly manufactured and imported from abroad?
- 100% imported from abroad and assembled in Vietnam?
- 100% imported to Vietnam
- Other means, please specify

**14.** What is the weakest link in your supply chain? Please specify.

---



---



---

**15.** What is the strongest link in your supply chain? Please specify.

---



---



---

**16.** Which countries or regions are your suppliers from?

- Europe
- Asia
- North America
- Latin America
- Africa
- Other regions, please specify

**17.** How is your customers 'attitude towards your products?

- Positive
- Positive but don't want to try nor to buy
- Positive but cannot afford to buy
- Neutral
- Negative

**18.** Do you consider customers in rural areas in Vietnam in your business and sales strategies?

- Yes. Which activities has your company been doing towards customers in rural areas?
- No

**19.** Does your company provide means of financial means of sales for customers? If yes please specify some of them.

---



---



---

**20.** What is your company's future plan to expand the market?

---



---



---

**21.** Do law and legislation influence much your business in Vietnam?

Yes, in which aspects?

No

**22.** Which kinds of incentives does your company receive from the government?

Feed-in-tariff

Tax reduction

Tax exemption

Others, please specify

**23.** What is your expectation towards changes in legislation in Vietnam concerning renewable energy application and development?

More applicable

More practicable

Others, please specify

**24.** How do you evaluate other sources of renewable energy such as wind energy, tidal energy, biomass energy, etc. as solutions to rural electrification?

High potential

Medium potential

Low potential

Not at all potential

**25.** Are you satisfied with the questionnaire?

Yes, please explain

No, please explain

**26.** Could you please give some of your suggestions for further changes or improvement to the questionnaire? Thank you very much for your interest and your participation!

---

---

---

## Appendix IV: Interview summary

Name of interviewee: Catherine Adelman

Title: General Manager of FOSERA Co. Ltd

Interviewing date: 18<sup>th</sup> Jan 2013

Summary of discussed issues:

1. The company's strengths, weaknesses, product features and company's future plan in terms of market expansion and product development
2. FOSERA's international markets, business partners, competitors, market entry modes in international markets, cooperation activities with different stakeholders
3. Different market entry options to enter the Vietnamese market; challenges and obstacles upon entering the market

Results:

1. FOSERA has expanded its market quickly in two years to many countries in Africa, Asia and in the future to South America. The company continuously develops its product features, strengthens its images and eliminates weaknesses
2. The company is interested in entering the Vietnamese market and cooperating with the Vietnamese government as well as with different NGOs provided that the company has good contact and engaged human resources
3. FOSERA's main market entry mode strategy is establishing distribution channels and cooperation with universities to provide training and maintenance

Name and title of interviewee: PhD. Dinh Ngoc Quang

Office: Institute of Energy-Power System Development Department

Ministry of Industry and Trade

Date of interview: 17<sup>th</sup> Jan 2013

Interviewing questions:

1. What is your evaluation of energy situation in Vietnam currently and in the future? In which fields or industry the shortage of energy can be seen most clearly?
2. Could you please describe a little bit the practical reality of Law on Renewable Energy, Law on Energy Saving and Efficiency and the decree 21/2011/ND-CP?
3. Could you name some laws and decrees that support the development of renewable energy in Vietnam recently?
4. What do you think about the commercial potential of solar PV off-grid in Vietnam?
5. Besides rural areas, do you think that customers who live in urban areas are also an important market segment in the future?
6. What is your evaluation of FOSERA's opportunity if they want to enter the Vietnamese market?
7. What is your evaluation of competition in solar energy sector on the Vietnamese market?
8. Do you think that FOSERA can sell products to rural areas only through cooperation with the government and funds from ODA projects?
9. Do you think that it is the right time for FOSERA to enter the Vietnamese market now?
10. FOSERA is a German company. Are there many solar companies from Europe entering the Vietnamese market? How about competitors from Asia such as China?
11. Do you think that off-grid solar PV project will be overcome or not be able to develop in Vietnam because of on-grid renewable energy projects in rural areas?

12. What is your evaluation of solar PV home systems in rural electrification in comparison to other renewable energy such as wind energy, biomass, biogas, etc.?
13. Have you heard any law or decrees in the future that will support foreign SMEs in renewable energy in general and solar energy in particular to enter the market?

Name of interviewee: Bui Thien Toan

Title: Representative of Business Development Department, Aschoff Solar Vietnam

Date of interview: 17<sup>th</sup> Jan 2013

Interview questions:

1. Could you please describe a little bit your company business activities in Vietnam?
2. Where are your company's international markets?
3. What is your evaluation of energy situation in Vietnam in the near future?
4. What is your evaluation about the economic potential of solar energy in Vietnam?
5. Could you please name a few companies who are competing with your company on the Vietnamese market?
6. What is your evaluation of current competition level among companies in solar energy field in Vietnam?
7. FOSERA is a German company which manufactures and sells solar photovoltaic home systems such as solar lamps, solar PV Pico home system. The company is intending to enter the Vietnamese market. Do you think that there is profit potential for the company to do business in Vietnam?
8. What kinds of incentives or support from the Vietnamese government that your company is receiving?
9. What is your evaluation of legislations on renewable energy promotion and its practice in reality?
10. What is your evaluation of applying solar PV off-grid household systems in rural electrification in Vietnam?

11. Products of FOSERA are of high quality and durability; however, the prices are higher than products of other companies, do you think that FOSERA can still compete on the Vietnamese market?
12. Solar water heating systems have become more popular on the Vietnamese market. Do you think that solar PV off-grid system is a more effective solution than diesel generators during electricity cut-off time?
13. Do you think that this is the right time for FOSERA to enter the Vietnamese market?

Name of interviewee: PhD. Petri Konttinen

Working position: Business Development Manager of Aurubis Finland Oy-  
Former member of International Solar Society in Finland

Name of interview Ms. Maarit Virtanen

Working position: Connect project manager

Date of interview: 12<sup>th</sup> December 2012

Interview questions:

1. From your experiences, what do you think about the business opportunities of renewable energy in general and solar energy in particular in Vietnam?
2. What should be done in order to attract more foreign investors in the field of renewable energy in Vietnam?
3. Do you think that solar PV stand-alone household system is a feasible and effective solution to rural electrification in developing countries and in Vietnam particularly?
4. Do you know any solar/renewable energy projects or investments between Finland and Vietnam recently?
5. What is your evaluation of Finnish companies' eagerness to do business in Vietnam in the field of solar energy?
6. Do you know any Finnish companies that are planning to enter the Vietnamese energy market?
7. Do you know any Finnish companies that are currently doing business in Vietnam in solar energy sector?

8. What are the hindrances or barriers for Finnish companies from approaching the Vietnamese market?

#### Appendix V: Potential business partners in Vietnam

1. DEVI Renewable Energies (Hanoi)
<ul style="list-style-type: none"> <li>• Website: <a href="http://www.devi-renewable.com">www.devi-renewable.com</a></li> <li>• Business type: retail sales and distributor</li> <li>• Service type: consulting, design, installation, construction, education and training services, research services</li> </ul>
2. Viet Trung Technology & Trading Co, Ltd (VTECHCO, Hanoi)
<ul style="list-style-type: none"> <li>• Website: <a href="http://www.samtrix.vn">www.samtrix.vn</a></li> <li>• Business type: retail sales; distributor; sales representative of Samtrix; sales agent of Schott, Kyocera, Suntech, Xantrex, SMA, Samlex, etc.</li> <li>• Service type: contractor service</li> <li>• Product type: solar electric power system; stand-alone solar PV system, on-grid PV systems, etc.</li> </ul>
3. New Energy Co., Ltd. (Ho Chi Minh City)
<ul style="list-style-type: none"> <li>• Website: <a href="http://www.sunnova.vn">www.sunnova.vn</a></li> <li>• Business type: importer, distributor of Sunnova products</li> <li>• Service type: consultancy, installation, engineering</li> <li>• Product type: LED lighting, solar electric power systems, battery charge controllers, photovoltaic systems, DC to AC power inverters, etc.</li> </ul>
4. Viet Linh Manufacturing and Trading Electric- Electronic Co. Ltd. (HCMC)
<ul style="list-style-type: none"> <li>• Website: <a href="http://www.ast-vn.com">www.ast-vn.com</a></li> <li>• Business type: manufacturer, trading company, distributor/wholesaler</li> <li>• Product type: solar equipment, backup generator, DC-AC Inverter, AC-DC converter, DC-DC converter automatic voltage stabilizer, charger, UPS, etc.</li> </ul>
5. Company for Technology Development (CFTD) Corporation Member of CFTD-Group



- Website: [www.cftd.com](http://www.cftd.com)
- Service type: development and consultancy; experiences with many different projects
- Product type: security devices, support devices, criminal science devices, traffic devices, fire prevention devices, etc.

#### 6. IC Energy Industry Co. Ltd. (Quang Nam province)

- Website: [www.icenergy.vn](http://www.icenergy.vn)
- Business type: member of IC Holding (Vietnam).
- Product type: solar street lamps, solar garden lamps, etc.
- The company is accelerating to become to first solar thin film panel manufacturing factory in Vietnam.

#### 7. Tuan An Group

- Website: [www.tuanan.com](http://www.tuanan.com)
- Business type: manufacturer, distributor of Hubbell, Nu- Lec, Wenzhou Lucheng Foreign Trade
- Product type: solar and wind power system using SIPV technology, solar panel, solar for home, solar system, wind system, solar & wind street lighting, etc.
- Completed project: Tuan An building with solar PV system (12.6 kWp); solar stand-alone systems in Binh Phuoc (3kWp); solar stand-alone system in Con Son (Can Tho) with capacity of 525Wp and in Vung Tau with capacity of 175W; on-grid solar PV systems in HCMC, Vung Tau; solar PV street light systems at the industrial zone Dong Nai, at the electricity company Khanh Hoa and at the building of trade and industry in Vung Tau.
- Partnership with Huebell, Schneider Electric, Wenzhou Lucheng, Solar World, Cygnus Power, Rehau, Roto Frank AG, Guoqiang Hardware Group Co., Ltd

#### 8. Son Ha TCC., JSC

- Website: <http://www.sonhatcc.com>
- Product type: solar PV ferry light and other solar products
- Partnership with Carmanah and Sabik (Sonhatcc 2013)

<b>9. Bao An Corporation</b>
<ul style="list-style-type: none"> <li>• Website: <a href="http://maynangluong.net/">http://maynangluong.net/</a></li> <li>• Business type: distributor of Aseries solar water heaters (Aseries, Megasun); distributor of Apollo, Bach Khoa, Solarhart (maynangluong 2013)</li> </ul>
<b>10. Green Field Consulting Co. Ltd. (Hanoi)</b>
<ul style="list-style-type: none"> <li>• Website: <a href="http://www.gfd.com.vn/">http://www.gfd.com.vn/</a></li> <li>• Service type: consulting service and technical assistance for biomass energy, biofuel, biogas, hydropower, etc. (Source Guides 2012)</li> </ul>
<b>11. Vietnam Energy and Environment Joint Stock Co. (VNEEC)</b>
<ul style="list-style-type: none"> <li>• Website: <a href="http://www.eec.vn">www.eec.vn</a></li> <li>• Service type: information provision and consultancy on energy and CDM projects; experiences with over 40 projects</li> <li>• Partnership with South Pole Carbon Asset Management Ltd. Co</li> </ul>

#### Appendix VI: List of potential competitors in Vietnam

<b>1. Seilar Energy Vietnam Co. Ltd. (Hanoi)</b>
<ul style="list-style-type: none"> <li>• Website: <a href="http://www.seilar.vn">www.seilar.vn</a></li> <li>• Business type: part of Seilar Energy Australia (SEA) group; wholesale supplier, importer, distributor, Distribution and guarantee service</li> <li>• Product type: solar water heater pumps, packaged power systems, photovoltaic systems such as solar PV power, solar lighting</li> </ul>
<b>1. Minh Ha Co. Ltd. (HCMC)</b>
<ul style="list-style-type: none"> <li>• Website: <a href="http://www.minhha.vn">www.minhha.vn</a></li> <li>• Business type: import, retail sales, wholesale supplier, sole agent of LEONICS</li> <li>• Product types: stand-alone solar power systems, grid power system, solar inverter, etc.</li> <li>• Service type: consulting, supply, design, installation</li> </ul>
<b>2. Saigon Solar JSC (HCMC)</b>

- Website: [www.maynangluong.com](http://www.maynangluong.com)
- Business type: manufacturer of different solar products, distributor of solar PV home systems of Solar World
- Product type: solar PV household system of 20W, 40W, 100W; solar PV systems of 200W, 500W, 1000W, >1000W. Include 4 LED energy-saving lamps, each with 12 V 4W in 5hrs (Solar PV of 20W); 8 LED energy-saving lamps, each with 12V-4W, in 6 hrs. (Solar PV 40W), 4 LED energy-saving lamps, each with capacity of 4W; 1 TV 21inch 220V (80W), 1 table fan 220V (45W) (Solar PV 100W). (maynangluong 2013)

### 3. Vu Phong Co. Ltd. (Solar V) (HCMC)

- Website: [www.solarpower.vn](http://www.solarpower.vn)
- Business type: manufacturer
- Products: solar PV stand-alone system (Solar V), LED energy-saving lamps (Solar V), solar panels, wind turbine, etc.
- Remark: Product price list can be checked at the company website. (Solarpower 2013)

### 4. Name: China Technology JSC (Hanoi)

- Website: [www.chinatech.vn](http://www.chinatech.vn)
- Business type: Manufacturer and trader
- Products: solar PV systems (2kW, 1kW, 500W, 300W, 200W, 100W), solar PV household systems (40W, 10W), solar lamps, solar street lights, solar recharger (Chinatech 2013)

### 5. VN Solar Inc.

- Website: [www.solarvn.com](http://www.solarvn.com)
- Products: solar water heat systems SKY; solar PV systems SKY (640W, 160W, 120W, 80W, 60W). For solar PV system of 640W, 140W, 120W and 80W, electric devices include 1 TV (70W), 1 DVD (30W), 1 electric fan (60W), 2 lamps (5W); for solar PV system of 60w, the included devices are 1 fan (40W), 4 lamps (5W). (usolar 2013)

### 6. Center Point Co., Ltd. (HCMC)

- Website: [www.solarpowervietnam.com](http://www.solarpowervietnam.com)
- Business type: Distributor of solar garden lights

- Products: solar household systems (2 LED lamps and components), solar signal lamps, solar street lights, LED lamps, solar heat water systems, etc. (cp-lights 2013)

#### 7. Gia Nam Corporation (Megasun)

- Website: [www.megasun.com.vn/vn/](http://www.megasun.com.vn/vn/)
- Business type: Distributor of Megasun products and solar PV household systems, solar lamps, solar street lights
- Products: Solar water heat system (Megasun), heat pumps, solar PV household systems (megasun 2013)

### Appendix VII: Previous and ongoing solar projects in Vietnam

- First solar PV household project in Mekong Delta (Tien Giang, Tra Vinh, Long Hoa, Hoa Minh) in 1994; cooperation between Solar Electric Light Fund (SELF), Vietnam Women's Union and Solar lab (Solar Electric Light Fund, 2012).
- First solar PV factory in Vietnam in Duc Hoa District (Long An province); 5MW/year during first stage (2009-2011); 10-million-USD investment by Red Sun (Dang, 2012, s. 16)
- First solar on-grid project (12kWp) in Vietnam on the roof of Ministry of Industry and Trade (MoIT); used solar PV modules of Solar World; sponsored by Germany; implemented by Altus (Germany) and Centre of New Energy (Hanoi University of Technology)
- Solar photovoltaic system (200kWp, 2012) at Intel VN factory in Vietnam; used solar PV modules of Sun Power; designed and implemented by GES
- Solar PV-diesel project (11kWp) in Cu Lao Cham (Quang Nam); implemented by Systech; sponsored by Sweden government and Quang Nam province

- Solar PV power plant (11kWp, 2010) in Thuong Trach Commune, Bo Trach(Quang Binh); sponsored by Suez Foundation; installed by Schneider Electric
- Solar PV system (1.3kWp) at primary school Minh Chau, Quan Lan and Health Centre Minh Chau; installed by RCEE and Abakus Solar AG within Vietnam Solar Campus project
- Solar PV systems (>1000kWp) in Truong Sa Island
- Solar PV station (1500Wp) in Ngoc Vung (Quang Ninh); implemented by Global Advanced Investment JSC.
- Solar PV system (5kWp) in Hon Chuoi (Ca Mau); installed by RCEE and Abakus Solar AG within Solar Campus project
- My Dinh National Conference Hall (154kWp, 2009)
- Solar PV system at Tam Ky Health Centre( Quang Nam); sponsored by Spain government and installed by Solar Lab (May 2010)
- XP Power Building (40kWp, 2012)
- Tuan An Corporation Building (12.6kWp) at Binh Tan district (HCMC); installed by Solar Lab (Devi-Renewable 2011.)
- Construction project of solar PV module manufacturing factory at industrial zone Chu Lai (Quang Nam) by Indochina Energy Industry Co., Ltd. (DEVI-Renewable 2011.)
- Construction project of solar PV module manufacturing factory (60MW/year) at Phong Dien industrial zone, Phong Dien district (Hue); investors from United Arab Emirates. (Do D.T 2013)
- Under-construction project of Big C in Binh Duong province (212kWp) (Do D. T 2012)

## Appendix VIII: Short Solar Energy Glossary

Alternating current (A/C): An electric current that reverses direction at regular intervals. Power producers distribute alternating current.

Direct current (D/C): An electric current flowing in one direction only.

Photovoltaic solar panels generate direct current.

Efficiency: The percentage of energy input an energy system puts out as useful energy. All energy systems suffer losses during operation.

Electrical voltage (V): The difference in potential between two points of an electrical device or circuit. Voltage is measured in volts.

Photovoltaic (PV) solar panels: An assembly of interconnected photovoltaic cells producing enough power to supply a device.

Power (W): The amount of electricity used instantaneously by a device or delivered instantaneously by a source of energy; measured in watts.

Volt (V): An international unit for measuring voltage, for which the symbol is V. One kV is equal to 1,000 volts.

Watt (W): The international unit for measuring power, for which the symbol is W. One watt is equivalent to a current of one ampere across a potential difference of one volt. One kW is equal to 1,000 watts.

Light-emitting diode (LED): is a semiconductor light source.

Watt-peak (Wp): is a measure of the nominal power of a photovoltaic solar energy device under laboratory illumination conditions. Kilowatt-peak or kilowatts-peak (kWp) is also used in the context of domestic installations (Wikipedia 2013)

(Schneider Electric 2011)