



Development of method and tools to replace motor in roof ventilation unit

Ivar Gullström

Bachelor's thesis
Construction Engineering
Vaasa 2013



BACHELOR'S THESIS

Author: Ivar Gullström
Degree Programme: Building Technology
Specialization: Structural Design
Supervisors: Anders Borg, Simon Nyman

Title: *Development of method and tools to replace fan motor in roof ventilation unit*

Date: 30 January 2013

Number of pages: 30

Appendices: 23

Summary

This thesis is done for Wärtsilä Power Plants. Before this thesis there was no developed method on how to change the fan motor in the roof ventilation unit in Wärtsilä's power plants. The purpose of the thesis was to develop a method for this. The thesis work has been done by coming up with different ideas of how the replacement could be done. Then the ideas have, through discussions, been developed to a solution that meets the demands set by the employer. Development of a detailed instruction manual for the replacement work was also part of the thesis.

For the method to work, two special tools had to be developed. The tools were designed both through hand calculations and by the use of digital designing tools. Manufacturing and assembly drawings of the special tools were produced and became a part of the end product.

The result was a method of how to change the fan motor, as well as necessary tools and instructions for doing the replacement. The result of the thesis is a special solution explicitly for the use of the employer.

Language: English

Key words: Wärtsilä, roof ventilation unit, fan motor replacement, instruction manual

Filed: theseus.fi

NOTE! In the official version of this thesis the appendices are excluded due to confidentiality.

EXAMENSARBETE

Författare: Ivar Gullström
Utbildningsprogram och ort: Byggnadsteknik Vasa
Inriktningalternativ/Fördjupning: Konstruktion
Handledare: Anders Borg, Simon Nyman

Titel: *Utveckling av metod och verktyg för byte av fläktmotor i takventilator*

Datum: 30 Januari 2013

Sidantal: 30

Bilagor: 23

Sammanfattning

Examensarbetet är gjort på uppdrag av Wärtsilä Power Plants. Innan detta examensarbete fanns ingen utvecklad metod för att byta fläktmotorn i takventilatorn på Wärtsiläs kraftverk. Målet med arbetet var att ta fram en metod för detta. Arbetet har skett genom att ta fram olika idéer hur bytet kunde gå till. Framtagna idéer har sedan, genom diskussioner, utvecklats till en lösning som passar de krav som ställts av uppdragsgivaren. Till arbetet hörde också att utarbeta en detaljerad instruktionsmanual som kan användas på plats under bytet av motorn.

För att den framtagna metoden skulle fungera krävdes att två specialverktyg utvecklades. Verktygen dimensionerades både med handkalkyler och digitala dimensioneringsverktyg. Tillverknings- och monteringsritningar av specialverktygen togs fram och blev en del av slutprodukten.

Slutresultatet blev en metod för att byta fläktmotorn, samt nödvändiga verktyg och instruktioner för att utföra detta. Resultatet av arbetet är en speciallösning explicit för uppdragsgivarens användning.

Språk: Engelska

Nyckelord: Wärtsilä, takventilation, fläktmotorbyte, servicemanual

Förvaring: theseus.fi

OBS! I den officiella versionen av detta examensarbete är bilagorna exkluderade på grund av konfidentiellitet.

Table of contents

Preface	1
1 Introduction	2
1.1 Background.....	2
1.2 Purpose	2
1.3 Approach	2
1.4 Requirements and Limitations.....	3
1.5 Structure	3
2 Background Information	4
2.1 Wärtsilä Power Plants.....	4
2.2 Ventilation Process	4
2.3 Roof Ventilation Unit.....	5
2.4 Personal Practical Experience.....	6
2.5 Practical Challenges.....	6
2.5.1 Roof Types.....	7
2.5.2 Radiators.....	8
3 Description of Working Method and Ideas	10
3.1 Removal of Motor from the Inside.....	10
3.2 Removal of Motor from the Outside.....	11
3.2.1 Openable Fan.....	12
3.2.2 Removable Fan	12
3.2.3 Hanging Fan	13
3.2.4 Rearrangement of Fan Parts	14
4 Chosen Solution: Removable Fan	15
4.1 Lifting Device	15
4.2 Sliding Device.....	17
4.3 Lifting Lugs	19
4.4 Material	20
4.5 Calculations	20
4.5.1 Safety Factor	21
4.5.2 Loads	22
4.6 Documents and Drawings.....	22
4.6.1 Instruction Manual.....	22
4.6.2 Drawings	23
4.6.3 Changes in Standard Drawings	23

4.7	How to Replace the Motor	24
5	Conclusion.....	25
5.1	Result	25
5.2	Reflections.....	25
5.3	Discussion	25
5.4	Further Development	26
	Bibliography.....	27
	Appendices	

Preface

This thesis is the concluding part of the degree programme in building engineering (Bachelor of engineering) at Novia University of Applied Sciences in Vaasa, Finland. The thesis work was carried out during the fall of 2012 in co-operation with the employer, Wärtsilä Power Plants.

I first came into contact with Wärtsilä when I applied for a summer job in 2011. I was given a position as a Civil Supervisor Trainee at a power plant project in Kingston, Jamaica. In the summer of 2012 I applied again and was sent to Kribi, Cameroun, also as a Civil Supervisor Trainee. In connection with the job interview in 2012 I was recommended to contact the Civil Pool if I needed a topic for my Bachelor's thesis. There were two topics available on such a short notice, of which this one was chosen and the work was to start when I arrived back in Finland.

I would like to take the opportunity to thank all who have helped and supported me in the making of this thesis. A special thanks to Eija Ollus, my boss; Simon Nyman, my instructor at Wärtsilä; and also to Dan Jakobsson, Markus Sandås and Lars-Johan Andersson at Wärtsilä who have guided me to the right solution.

I would also like to thank Claudia Martinez at Wärtsilä who made a field trip to Jamaica possible.

Outside Wärtsilä I would like to thank my instructor at Novia, Anders Borg, as well as Allan Andersson, Kaj Rintanen and Mikael Ventin for the help and support they have given. I would also like to thank Ella Enbacka for helping me with the language and the spelling.

Last but not least I would like to thank the whole Civil Pool at Wärtsilä for brightening my days in the office.

Ivar Gullström

Vaasa, January 2013

Introduction

This chapter introduces the reader to the background and the purpose of the thesis. It also describes the approach and what is included in the thesis.

This thesis is done for Wärtsilä Power Plants. It consists of a special solution for how to replace a fan motor in roof ventilation units in Wärtsilä Power Plants' projects. This solution is developed explicitly for Wärtsilä Power Plants' use. Henceforward Wärtsilä Power Plants will be referred to as Wärtsilä.

Due to confidentiality the appendices are excluded in the official version of the thesis.

1.1 Background

The roof ventilation units were introduced as a standard solution in Wärtsilä's power plants in 2009, which means that they are a relatively new solution. Up to the present there have not been any problems with the fan motor in the units, so no fan motor has had to be replaced yet. As time passes and the number of projects with roof ventilation units increases, the risk of a motor burning or getting damaged rises. This thesis revolves around the roof ventilation units and the replacement of the fan motor.^[1]

1.2 Purpose

The main purpose of this thesis is to develop a method and produce an instruction manual on how to replace the fan motor in the roof ventilation units in Wärtsilä's power plants.^[2]

Since no fan motor has been replaced yet there is not really any method for how to do this. As of now the only available solution would be to bring a mobile crane to lift the whole roof ventilation unit down to the ground and then replace the motor. Depending on where in the world the project is situated the cost of the crane can be very high, if a crane is available at all. This means that a totally new method has to be developed. This method should be economical, safe and as simple as possible.^[1]

1.3 Approach

When carrying out a literary work like this, one of the most crucial methods is to collect information from suppliers, experts and people working with the roof fans. Several experts

from Wärtsilä with experience and knowledge of project management, site work, development and the ventilation process have been consulted. Experts from a supplier of the roof ventilation units have also been consulted.

The decisions taken in this thesis are often based on discussions with these experts, but my own practical experience has also been of significance. Where applicable, Eurocodes and standards as well as literature and Wärtsilä's internal documents have been used as sources.

1.4 Requirements and Limitations

Since all Wärtsilä projects are different it can be difficult to find a solution that fits all projects. Therefore the thesis has been limited to certain types of projects. This means that the method must work on at least these types of projects. The best solution would, however, be to come up with a system that would work with all types of projects.^[2]

Wärtsilä's requirements were that the solution should be applicable in future projects where the radiators are situated on the roof.^[2]

Risk assessment and health, safety and environmental documentation are not included in this thesis.^[2]

1.5 Structure

The structure of the thesis is as follows:

Chapter 2 introduces the reader to the company and describes some basic facts and information about the ventilation process and roof ventilation unit. It also describes the practical problems of the replacement as well as my own experience of the units.

In Chapter 3 the thesis work process is described and different ideas about possible ways of replacing the fan motor are discussed and evaluated.

Chapter 4 describes the method chosen for replacing the motor and how it was devised. It also describes the tools and documents developed for the replacement.

In Chapter 5 the result is described and discussed. This chapter also describes the further development of the method and the tools.

Background Information

In this chapter the reader is introduced to Wärtsilä. The chapter also includes basic information about the ventilation process and the roof ventilation units and describes the practical problems of how to replace the motor. My own practical experience of the roof ventilation units is also included in this chapter.

1.6 Wärtsilä Power Plants

Wärtsilä Power Plants is one of three businesses in the Wärtsilä Corporation^[3]. Power Plants concentrates on supplying flexible power plant solutions all around the world^[4]. Wärtsilä has a large reference base with over 4600 power plants delivered to almost 170 countries^[4]. These have a total capacity of over 49GW^[4]. Wärtsilä delivers over 100 power plant projects per year^[4].

1.7 Ventilation Process

The combustion in the engines in the Wärtsilä power plants produces a lot of heat. In order to maintain a good temperature in the engine hall, ventilation is crucial. For this several ventilation units are installed on both the walls and on the roof^[5]. Inlet ventilation units are placed on both long sides for each engine^[5]. There are roof ventilation units or roof monitors placed on the roof as outlets^[5,6]. A 3d model of an engine hall with roof ventilation units is illustrated in Figure 1.^[1]

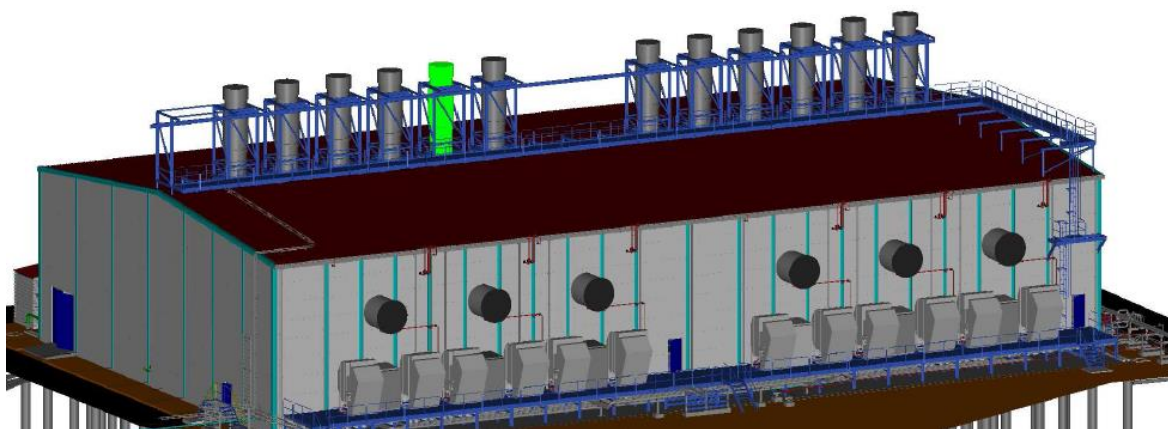

Figure 1. 3d model of engine hall. Roof ventilation unit highlighted.

1.8 Roof Ventilation Unit

A roof ventilation unit normally consist of a damper, a duct, a silencer, a joint, a fan, a base plate and an inlet cone (Figure 2)^[7]. In between the fan and the parts adjacent to the fan there are rubber gaskets to prevent leakage^[8]. All other joints are sealed with sealant^[8]. The roof ventilation units and the fan motor in these are the subject the whole thesis revolves around.

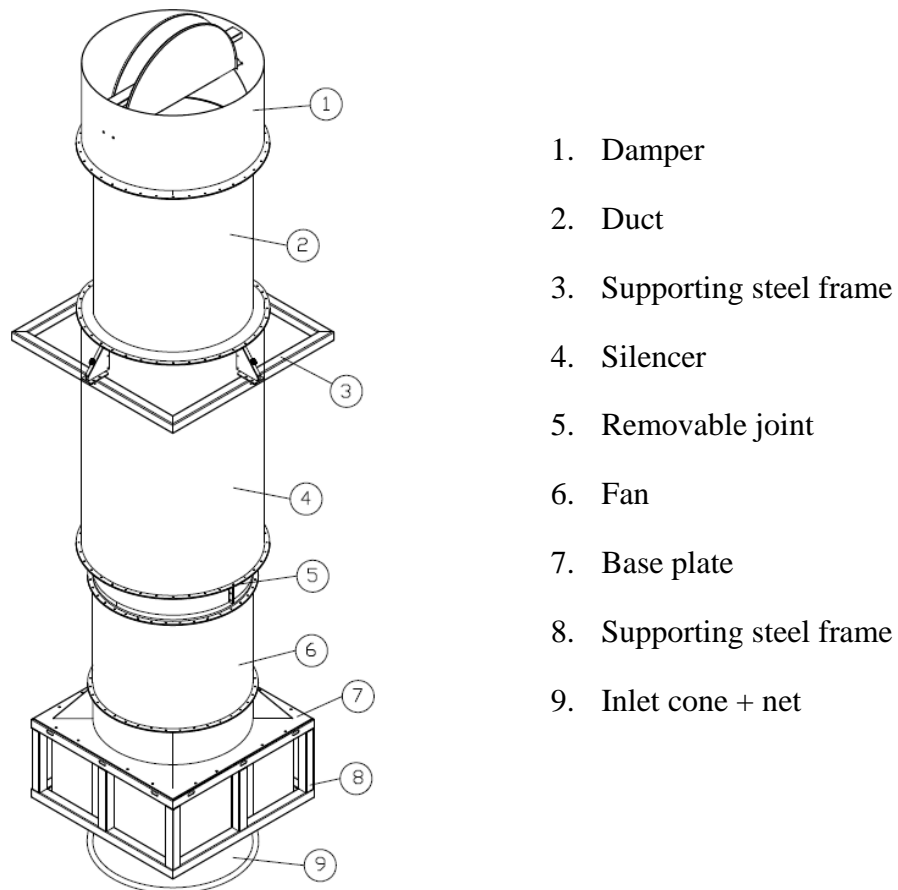

Figure 2. 3d picture of roof ventilation unit and list of parts.

There are two different types of roof ventilation units: low noise and ultra-low noise. The practical difference between these is the length of the silencer. As a result of this the total height of the unit and the space between the silencer and the fan can vary. In the end this does not affect the result but it has been taken into consideration. Both types of roof ventilation units are specified in standard drawings in Appendix A1 and A2. ^[1,7,9].

In addition to this the composition of the roof ventilation units can vary from project to project depending on a variety of factors, for instance in projects where no sound proofing is needed there might not be any silencers at all. ^[10]

Another example is projects with radiators on the roof^[11]. In these projects the height of the roof ventilation units changes depending on which height the radiators are at^[11]. This is to prevent the radiators from using the hot ventilation air as cooling air^[11].

The main purpose of the roof ventilation unit is to remove the heat from the engine hall, but it can also be used as a smoke extractor in case of a fire. However, if the roof ventilation unit is to be used as a smoke extractor, it needs to be equipped with a special fan that allows high temperatures. This will lower the efficiency during normal use of the fan.^[1,12]

1.9 Personal Practical Experience

During the summer of 2012 I was working for three months in a Wärtsilä power plant project in Cameroun as a Civil Supervisor Trainee. During this time one of my tasks was to install the roof ventilation units. In this way I got a basic understanding of how it is to work with the units.

At the end of September 2012 I was sent to Jamaica with two representatives from a supplier for a week. The main reason for the trip was to repair some leaks in the roof ventilation units. My task was mostly to take pictures and make a documentation of the work done, but also to help with the practical work on site. During this trip a lot of knowledge and information was gathered by taking pictures and by working with the roof ventilation units.

1.10 Practical Challenges

There have been a whole lot of practical challenges that have had to be considered to enable the development of a working solution.

The biggest challenge has been the weight of the fan and its motor. The whole roof ventilation unit, including all parts shown in Figure 2 except for the steel frames, weighs about 1700 kg^[7]. The actual fan weighs about 600 kg of which the motor weighs about 300

kg^[13,14]. This has had to be considered when using any surrounding constructions as support and in lifting or moving the fan.

Another challenge has been the space. In projects where the radiators are placed on the roof the space is limited because of the roof trusses being on the outside^[15]. In projects where the radiators are placed on the ground there is plenty of space on the roof^[16,17]. However, inside the engine hall the space is limited because of the roof trusses being on the inside^[16]. In both cases the space inside the engine hall is also limited by an overhead crane^[15,16].

The roof ventilation unit as a whole is a standard solution and, if possible, changes are not to be made to any part of the unit. Any changes would make it a special order, which means a longer delivery time.^[1]

The gaskets in between the base plate and the fan have also been a problem because they have to be removed prior to sliding the fan to avoid damaging them. They also have to be put back after the motor has been replaced to avoid leakage. To be able to move the gaskets the fan has to be lifted and with the limited space and the weight of the fan lifting is a challenge.^[1]

The risk of damaging the roof, the surrounding constructions or injuring workers is also a factor to take into consideration when moving big/heavy equipment. These are risks that need to be minimized.^[2]

An overall problem is that there are almost no projects that are exactly identical.^[18]

In addition to all this, the solution should be so simple that anyone would be able to replace the motor if he/she were given the instruction manual and the right tools.^[2]

The combination of all these problems makes it hard to find a solution that is both economical, safe and works in as many projects as possible.

Roof Types

The fact that there are different roof types has also been taken into consideration. There are differences in both the construction of the roofs and the top material. From a structural point of view there are three main types of roofs: built in situ, elements and welded steel sheets.^[2]

The load bearing capacity of the different roof solutions varies so therefore calculations have to be made according to the solution that has the lowest capacity: roofs built in situ. These roofs are designed to bear a maximum load of 0.75kN/m^2 .^[2]

There are also special cases with other roof types, for instance concrete, but these are not taken into consideration in this thesis.^[2]

Radiators

In Wärtsilä power plant projects the radiators might also be placed on the roof (Figure 3)^[19]. This limits the working space around the roof ventilation units but also adds the possibility to utilize the steel structure for the radiators for instance for lifting.

In some projects with radiators on the roof a monorail is located on the radiator platform (Figures 3 & 4)^[19]. This monorail can be used for lifting the motor from roof level to radiator platform, but also for lowering it from roof to ground level^[20]. In projects without monorail a special wagon for lifting the radiator fan motors is available instead^[21]. This wagon can also be used to lift the motor of the roof ventilation unit fan, provided it has the lifting capacity^[21].

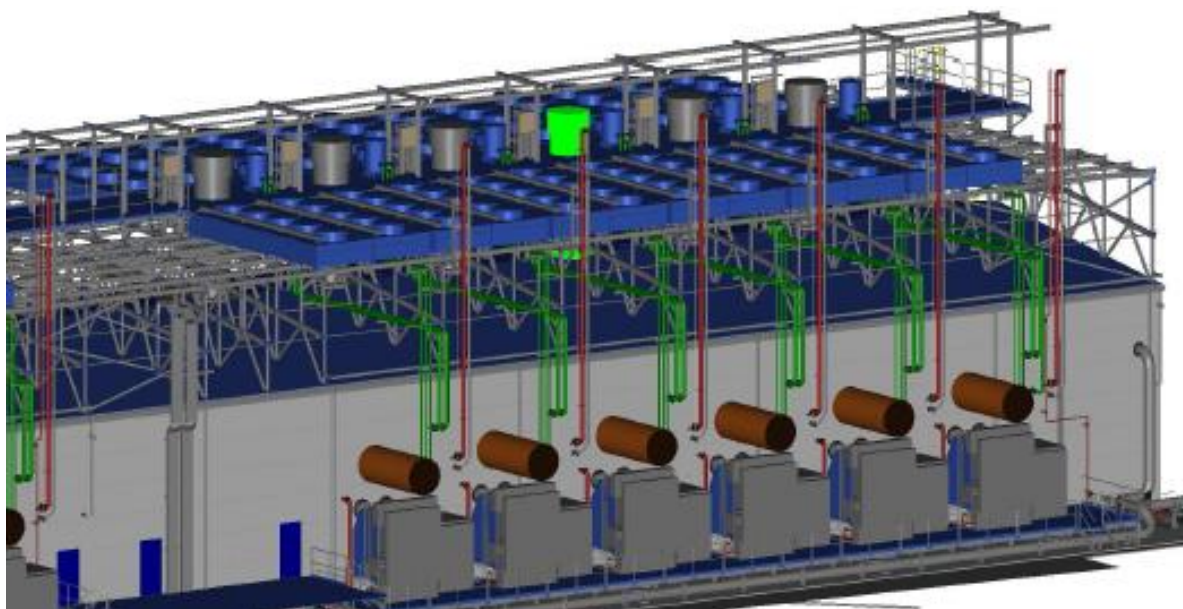

Figure 3. 3d model of engine hall with radiators on the roof. The highlighted part is one of the roof ventilation units.



Figure 4. Radiator field and roof ventilation unit duct and damper.

A certain amount of pipes and cables are needed for the radiators to work. As can be seen from Figure 5 these pipes and cables need a lot of space and this complicates the lifting of the motor.



Figure 5. Roof ventilation units under the radiator field.

This thesis will primarily focus on projects where the radiators are on the roof, though the optimal solution would be to find a way that works with every type of project.^[2]

Description of Working Method and Ideas

There are many possible solutions to this problem. In this chapter the thesis work process and ideas of how it could be possible to replace the motor are explained. Each idea is presented with pros and cons in a subchapter. One of these ideas has been chosen for further development.

The subject and the problem were discussed in the spring of 2012, but the main work with the thesis was started in September 2012 with a kick-off meeting. At the meeting the problem was discussed and some basic ideas of how the replacement could be done came up. After that a lot of information was collected by studying drawings and consulting experts. Some basic ideas were developed to see what problems would occur and when the ideas were at a certain stage all but one were discarded through discussions with experts from Wärtsilä. The one that was left was further developed and started to form a sustainable solution. When the idea seemed feasible, calculations, drawings and an instruction manual were produced. The production of these is further explained in chapter 4.

1.11 Removal of Motor from the Inside

One of the first things to decide was whether the motor should be replaced from the inside or the outside of the engine hall.

A positive thing about removing the motor from the inside was that the removal would not be affected by the climate or weather, but, on the other hand, there would be a lot of noise and heat from the engines.

If the motor were to be removed from the inside, some kind of working platform would be needed. One solution to this would be to install movable suspended scaffolding^[22]. A positive thing with this is that there are two H-beams located in the ceiling. These H-beams run parallel to the ridge of the engine hall. The beams are to support the steel structure for the roof ventilation units and they could also be used to support the scaffolding. This scaffolding could also be useful for other repairs, for instance when the electricians need to change the lights. In Figure 6 on the next page there is an example of what the roof ventilation unit can look like seen from the inside of the engine hall.



Figure 6. Roof ventilation unit's inlet cone and H-beams inside the engine hall.

Possible problems would be: the weight of the scaffolding and loads placed on it, limited space for scaffolding because of the overhead crane, reaching the motor from the scaffolding and also getting the motor down onto the scaffolding and the new motor up into the fan again. The scaffolding would also have to be certified for personal transport.

This solution was discarded because there are too many aspects to consider and in the end it would probably be an expensive solution. Also, if the radiators are not situated on the roof, the roof trusses will be on the inside, which makes it impossible to use a moveable platform. In some projects there are also plates to prevent buckling in the H-beams. These would also prevent the use of a movable platform.

1.12 Removal of Motor from the Outside

If the motor were to be removed from the outside there would not be the same level of noise, but instead the climate could be a problem when working on the outside (for example lots of rain/snow, extreme cold/heat, wind). In most of the countries where Wärtsilä operates the weather is relatively good^[1].

However, the main reason for removing it from the outside is economical. If it were removed from the outside, the only thing needed would be some kind of lifting device and some supporting structure. These should be designed so that they can be manufactured by the client, which means Wärtsilä would have the possibility to only supply the drawings

for how to manufacture them. This would be practical for old projects when only the drawings can be sent to the client instead of having to send the devices, which could have a long delivery time.

Openable Fan

One idea is an openable fan where half of the fan could be turned out to one side. The problems with this would be that turning out half of the fan would create a large torque on the hinges. Also, there would be problems with the gaskets and it would be difficult to get the fan air tight in the joints.

Another openable fan solution would be to make a big service hatch. This hatch would be relatively easy to make air tight. On the other hand it would be difficult to reach the bolt keeping the rotor in place. The shell of the fan would also be weakened by such a hatch.

Both these solutions meant that the design of the fan would have to be changed and this is not acceptable. Therefore this solution was discarded.

Removable Fan

Instead of opening the fan the whole fan could be pulled out to the side as shown in Figure 7. The problem with this method would again be the gasket. The fan cannot slide out on the gasket because this could damage it. This means that it would have to be removed first. It would also have been difficult to get the gasket back in its place after the motor had been replaced. To be able to easily remove and reinstall the gasket, the fan would have to be lifted. For this some kind of lifting device would be needed.

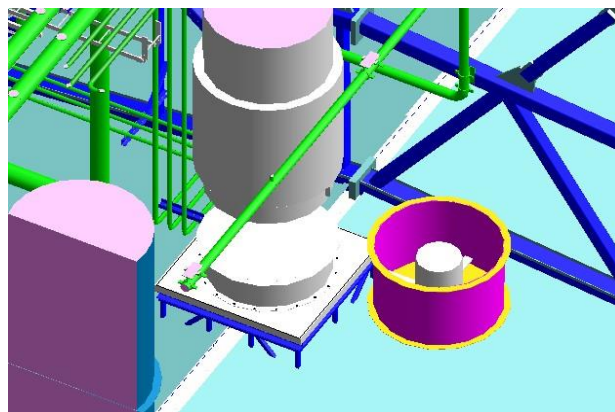

Figure 7. Fan slid out from the base plate.

To be able to slide the whole fan out some kind of supporting structure to slide it on would be needed. Space would also be needed for this structure so therefore the fan would have to be lifted even higher.

When the fan is slid out there will have to be some kind of lifting device that can lift the 300 kg motor out of the fan and then the motor would have to be removed from the roof.

This idea was chosen to be further developed and used to replace the motor.

Hanging Fan

This idea is basically the same as the removable fan. The difference is that if the fan were to be fastened to the silencer (Figure 8) instead of lying on the base plate, there would not be any problem with the gaskets when the fan was removed. Then the lower part could be removed first to make room for some supports. After that the fan could be let down so the other gasket could be removed and then the fan could be slid out. The rotor could then be detached and finally the motor could be removed. This solution would demand that the radiator structure could take the extra weight of about 600 kg/fan and also that the supports that keep the silencer in place can take the extra weight, which probably means changes in the design of the silencer.



Figure 8. Example of a hanging fan. The galvanized steel part is the fan and under it is the removable joint.

This solution was discarded because if the fan were to hang in the silencer it would get a pendulum effect in case of an earthquake, which means that there would need to be more steel constructions and the existing steel constructions would have to be stronger^[18]. Also the changes of the silencer supports would extend the delivery time of the roof ventilation units and that is not acceptable.

Rearrangement of Fan Parts

The duct between the damper and the silencer weighs much less than the fan. This means that if the roof ventilation unit parts were rearranged so the duct would be positioned under the silencer and on top of the fan, it should be relatively easy to remove the duct. This again would give sufficient work space on top of the fan to either lift the whole fan or to disassemble the rack, motor and rotor and just lift them out.

The downsides of this are that you would still have to loosen the rotor from under and if the parts are rearranged there might be some change in the noise level.^[1]

This idea could also be combined with some of the other ideas if the work space above the fan is insufficient.

Chosen Solution: Removable Fan

This chapter explains in detail the development of the chosen method.

Shortly described the chosen solution is to remove the fan from its position and then remove the motor and lift it up through the platform using the monorail or the lifting wagon for the radiator fans^[20,21].

1.13 Lifting Device

As mentioned in chapter 3.2.2 the fan has to be lifted to be able to remove the gaskets and install a sliding device under it. For this a lifting device has been developed.

Since the parts of the fan cannot be altered, the device had to be external and easy to attach to the fan^[1]. The result was a structure built by RHS-profiles. The structure has been designed with fixed connections and pinned footings. This so no diagonal bracings would be needed, which results in less material and less self-weight. There is also more work space when the bracings are left out. For the fixed connections to be fixed in practice, the tolerances for the bolt holes had to be minimized and were decided to be 1mm^[23]. Since the column is standing on the base plate the footing has been made thick, wide and long so the pressure is distributed on a bigger area^[23].

The device has been designed as two frames kept together with two bracings (Figures 9 & 10). In this way there will be no load on the bracings when lifting the fan, since all forces from the lifting goes from the beam down the columns. The bracings are just there as structural parts to keep the frames standing.

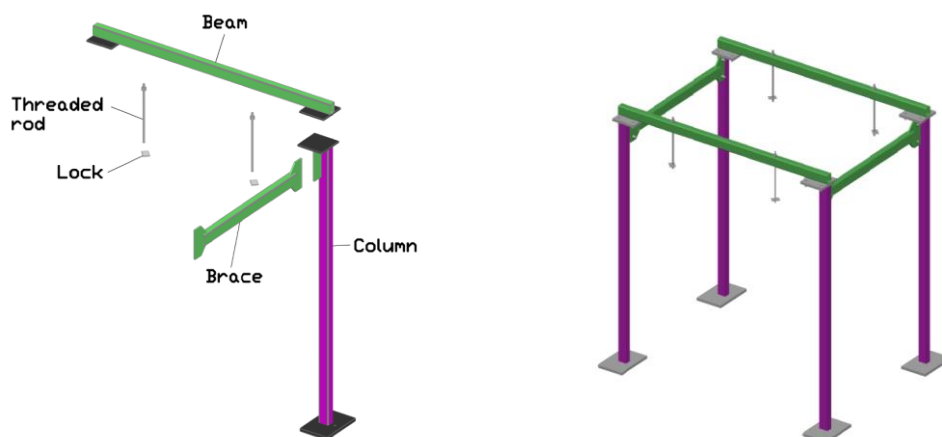

Figure 9 (left). Parts of the lifting device.

Figure 10 (right). Complete 3d model of lifting device.

The device frame has been designed in eight main parts for easy transportation and storage. These are to be mounted on the base plate of the roof ventilation unit and fastened to it with existing bolts. In addition to these parts there is a lifting mechanism that uses four lifting points. The decision to have four lifting points was made because when the fans are lifted for installation they are lifted in four points. In this way the fan is also stabilized and prevented from swinging when lifted.

The actual lifting mechanism has been kept as simple as possible for the parts to be easy to manufacture. It is designed as four threaded rods with a nut welded in the upper end. This part goes through the beam of the lifting device so the nut is located on the top of the beam and the rod goes down through the bolt hole of the fan's flange. A thrust ball bearing is to be placed between the top nut and the beam to make it turn easily. A lock made of a flat iron with a nut welded to it is to be placed under the fan's flange to prevent the nut from turning as the rod turns. The whole fan will be lifted by turning the rods with a wrench. For the rods to be equally loaded they should be turned in pairs, one side at a time. A sketch of the lifting mechanism can be seen in Figure 11.

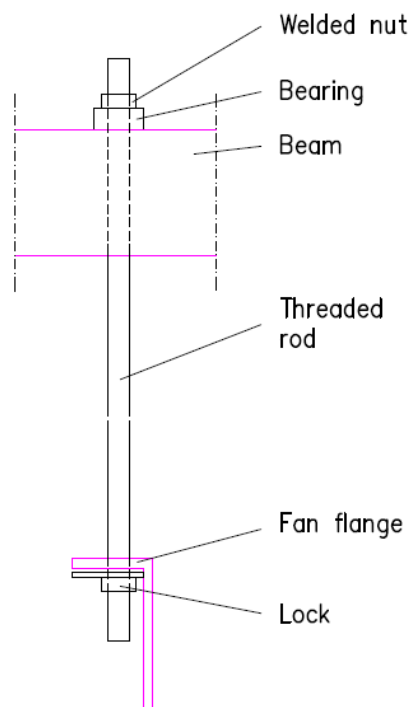

Figure 11. Section of lifting mechanism.

Even though there are four lifting points the device has been designed so it could use only two lifting points. This is a safety precaution because if the fan were to be lifted unevenly the load would be distributed on a minimum of two points. The device is made to lift the fan from above to get tension in the threaded rods.

For the lifting device to fit, some changes had to be made to Wärtsilä's standard drawings. These changes are described in chapter 4.6.3.

A 3d model of the lifting device mounted on a base plate can be seen in Figure 12.

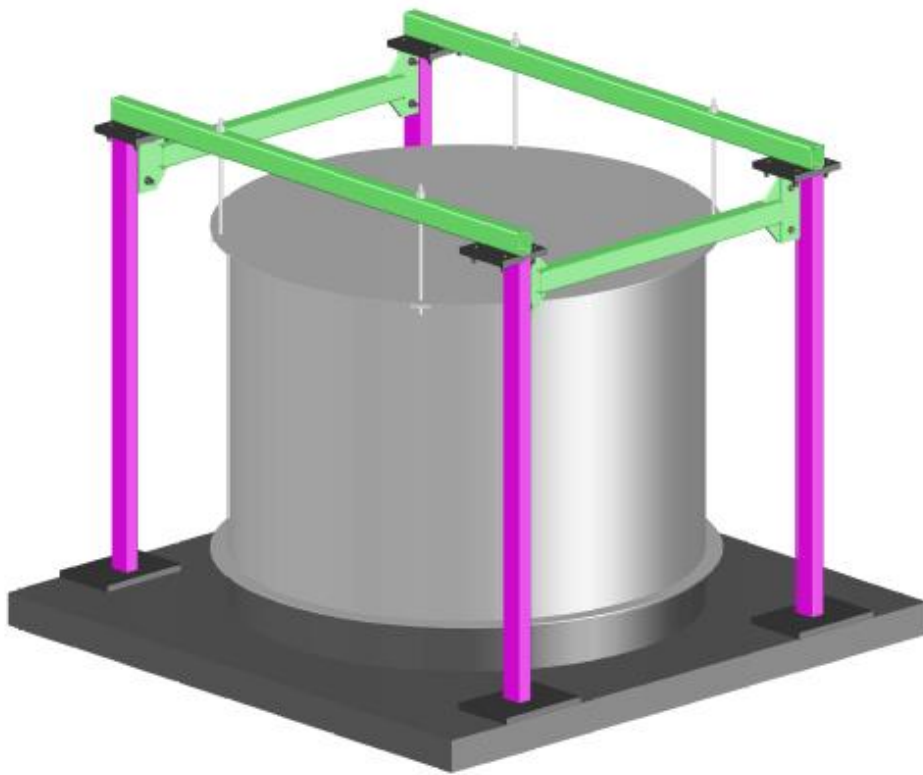

Figure 12. 3d model of lifting device mounted on a base plate.

1.14 Sliding Device

To slide out the fan to the side a support or sliding device is needed. The idea of the sliding device is to lower the fan down onto it and then slide it out to the side so it will be possible to remove the motor.

The sliding device has been designed as two beams made of IPE-profiles, which each have a cut SHS-profile on top. The SHS-profiles will slide on ball bearings on top of the IPE-beams. The beams are to be fastened with two bolts to the flange of the base plate. (Figures 13, 14 & 15)



Figure 13 (left). 3d model of sliding device.

Figure 14 (right). Section of sliding device.

Each beam is only supported in two points, in the middle and in one end. This makes the fan create a seesaw effect while slid out, which will create tensions in the rear support and pressure on the middle support. These supports are the flanges of the base plate and this is considered in the calculations. (Figure 15)

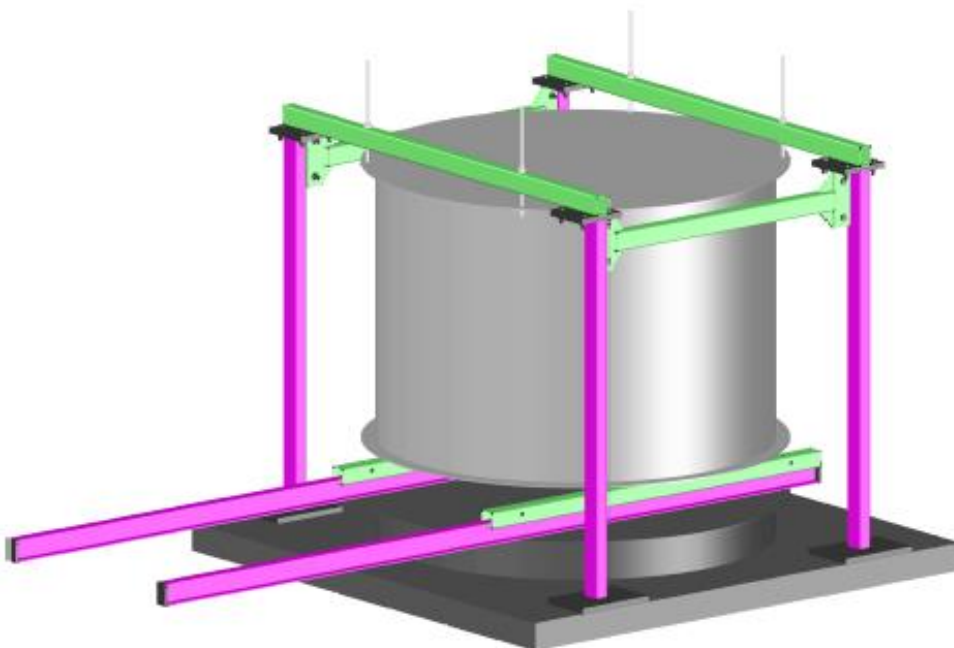

Figure 15. 3d model of mounted sliding device and lifted fan.

A hole with threads is made in each SHS-profile so the fan can be bolted to it. This is to prevent the fan from sliding or tilting off the device. There is only one hole in each profile so there will not be any problem of mismatching the hole of the flange and the hole of the device.

The space between the beams has been made so the fan's rotor will not come down further than onto the sliding device when it is released from the axle.

1.15 Lifting Lugs

Normally there is only one lifting lug on the motor and it is located on the side of the motor as seen in Figure 16. This will complicate the lifting of the motor because of horizontal rotation when the motor is loosened from the rack. Because of this two more lifting lugs have to be added on the bolts keeping the motor fastened to the rack. These have been designed as two flat steels with two holes in each so they will be easy to manufacture on site. With these lugs it will be possible to lift the motor straight up without horizontal rotation. Because of the lugs being fastened to the rack, a part of the rack also has to be loosened and lifted with the motor. This will add some additional weight but that will not be a problem for the monorail that will be lifting the motor^[20].



Figure 16. Fan motor with lifting lug.

1.16 Material

Wärtsilä delivers projects all over the world^[4]. Because of this the material of the devices has to be decided according to the climate at the project's location. The devices are meant to be outside only for short periods (a couple of days) at a time. It is stated in the instruction manual that all material is to be stored protected from weather and moisture.

The chosen standard material for the devices is S235J2. This decision is based on the weather conditions in the locations where Wärtsilä operates as well as on the availability of the material at these locations.

Depending on the location of the project there might be extreme temperatures. However, it is not critical to the process of the power plant if one fan is not operating, so it is assumed that no one will replace a motor in less than -20°C. High quality material might not be available in some countries where Wärtsilä operates. Therefore the grade of the material has been decided to be the lowest grade available according to EN 10027-1^[24].

The materials of the bolts and nuts have been chosen according to DIN 931^[25] and the materials of the threaded rods have been chosen according to DIN 975^[26].

All parts should also be galvanized or painted to protect them from corrosion. This is not only for the protection of the parts, but also to prevent corrosion stains on the roof ventilation units, surrounding steel structures, roof and so on.

1.17 Calculations

All calculations have been made according to Eurocode or other applicable standards. Standards and literature used in the calculations are listed below:

- *EN 1990*^[27]
- *EN 1991-1-1*^[28]
- *EN 1993-1-1*^[29]
- *EN 1993-1-8*^[30]
- *ENV 1993-1-1*^[31]
- *Hitsatut profilit*^[32]
- *Byggkalendern*^[33]

Both the sliding device's and the lifting device's main parts, such as beams and columns, have been dimensioned in Autodesk Robot Structural Analysis Professional 2012. The connections and the footing of the column were calculated manually in PTC Mathcad 14.

The flanges of the base plate and the fan have also been calculated manually in Mathcad.

For the lifting device the calculations of the beams, braces and columns made in Robot can be found in Appendix B1. The calculations of the connections done manually in Mathcad can be found in Appendices B3-B4. The calculation of the lifting mechanism can be found in Appendix B5.

For the sliding device the calculations made in Robot can be found in Appendix B2. The calculations done manually in Mathcad can be found in Appendices B7 and B8.

The calculations of the fan's flange can be found in Appendix B6 and the base plate's flange in Appendix B9.

The calculation of the lifting lugs can be found in Appendix B10.

The dimensioning of the bearings used for the devices was done by calculating the maximum static load per bearing. According to the calculated load suitable bearings were chosen from a table in SKF's online product catalogue^[34,35]. The calculation of the bearings for the sliding table is presented in Appendix B8 and the calculations made for the bearings for the lifting mechanism is presented in Appendix B5.

Safety Factor

If something were to go wrong when the motor is replaced it could have devastating consequences. If any of the devices were to break, the whole fan could start rolling and in a worst-case scenario roll off the roof and fall on something or someone. Because of this the safety factor has been set higher than recommended in Eurocode for structural steel^[27].

In a meeting with the instructors and other experts from Wärtsilä it was decided to set the safety factor of the load at 3. This to make sure that the tools cannot be overloaded by mistake.^[36]

The fact that someone has to lie under the fan while it is out on the sliding device was one factor taken into consideration.

According to EN 1990 the highest safety factor for permanent load, in this case the self-weight, is 1.35 so 1.35 has been used^[27].

Loads

The loads were based on the weight of the fan multiplied with the safety factor. Also the self-weight of the lifting device and sliding device were considered and multiplied with safety factors. The lifting device is also designed to withstand a horizontal load of 1.5kN. This load is distributed as a horizontal load at the top of each column. This represents the wind multiplied with the safety factor and was decided in consensus with the instructor at Novia^[23].

The sliding device is designed to bear the load of two persons at the same time as the fan is slid out. This in case the persons doing the replacement climb on the sliding device. It has been assumed that one person weighs 100 kg.^[18,23]

1.18 Documents and Drawings

In this subchapter all documents that will be used for the replacement of the fan motor are described. Also changes that have had to be made to Wärtsilä's own standard drawings are described here.

For all documents made Wärtsilä's templates have been used as base.

Instruction Manual

A step by step instruction was made as a support document for the site personnel when the motor is to be replaced. The instruction manual and the drawings of the devices are made to be sufficient for anyone replacing the motor.

A supplier's representative for service and spare parts has read and given comments and opinions on the manual. The manual has been updated according to the feedback.^[37]

The instruction manual has been read by Wärtsilä and approved as Version 1.0. Version 1.0 can be found in Appendix D.

Drawings

Both the lifting device and the sliding device have been modelled in detail in Tekla Structures 18. As Wärtsilä has ready templates for drawings in DWG-format the drawings made in Tekla were exported to DWG-format and completed in Autodesk AutoCAD 2012.

The result was a total of seven manufacturing drawings and two assembly drawings.

The drawings of the lifting device can be found in Appendices C1-C6, the drawings of the sliding device can be found in Appendices C7-C9 and the drawing of the lifting lug can be found in Appendix C10.

Changes in Standard Drawings

For this solution to work in all future projects changes had to be made to Wärtsilä's standard drawing.

The minimum space needed for the lifting device is 1650 mm from the top of the base plate and to the top of the threaded rod. From that level downwards a minimum of 400 mm is needed for the beams and the lifting of the fan. This has been ensured by specifying the lowest level of the silencer to be 1700 mm and the height of the base plate's ring to be 120-150 mm. This eliminates the variation in space that comes from the different types of silencers mentioned in chapter 2.3. This solution forces the roof ventilation units to grow upwards instead of shrinking the joint. By specifying these dimensions and considering the maximum height of the fan, which is 1000 mm^[12,13], a working space of 380 mm is achieved.

Also the position of the bolt holes in the flange of the base plate had to be fixed in the drawing. This to make sure that both the sliding device is mountable and the lifting device's threaded rods coincide with the bolt holes in the fan's flange.

Support plates are welded on the base plate^[7,9]. The position of these plates had to be fixed in the drawing to prevent them from coinciding with the footing of the sliding device.

At the time of writing the new revision of the standard drawings has not yet been published, but the initial standard drawings can be found in Appendices A1 and A2.

1.19 How to Replace the Motor

This subchapter describes how the replacement of the fan motor is to be done.

The first thing needed for working is space. Between the fan and the silencer there is normally a joint. This is made by two steel ducts and a steel strap. First the steel strap is removed and then the two steel ducts. This should create sufficient space for lifting the fan. [7,9]

The fan has to be lifted to make it possible to remove the gaskets to prevent them from getting damaged. Because of the weight of the fan a lifting device is needed and has been developed, as explained in chapter 4.1.

For the motor to be reachable the whole fan has to be slid out to the side. For this a sliding device has been developed. This will be put under the fan after it has been lifted, as explained in chapter 4.2.

When the fan has been slid out the rotor has to be loosened from under the fan. There is sufficient space under the sliding device to get to the rotor and it can be let down onto the sliding device. After the rotor has been loosened there is nothing that prevents the motor from being lifted straight up.

The motor will be lifted out of the fan with the monorail that is located on top of the radiator field^[20]. For this to be possible a part of the radiator field platform has to be removed to make a sufficient opening. The motor can then be lifted to the level of the radiator field and with the monorail transported to the edge of the building and down to ground level for repairs or replacement. If there is no monorail available on the radiator field there is a lifting wagon for the radiator fans instead^[21]. In that case the lifting wagon will be used to lift the motor from the roof level to the radiator field level. ^[38]

The method is described more in detail in the step by step instructions in Appendix D.

Conclusion

This chapter describes the conclusion of the thesis from both Wärtsilä's and my point of view. This chapter also includes suggestions on what could be further developed.

1.20 Result

Prior to this thesis Wärtsilä did not have any solution for how to replace the fan motor in the roof ventilation units. Now they do not only have a solution, but also the designs for the necessary tools as well as an instruction manual on how to do the replacement.

Both the instruction manual and the designs have been approved as Version 1.0 and they are a good base for further developments and improvements.

1.21 Reflections

This thesis is part of my education and has to be completed for me to graduate. I have learnt the process of developing a product and the importance of consulting experts and getting opinions from different parties. I have also gained a certain self-awareness and learnt my lesson that when making a time schedule there has to be a certain amount of extra time included for mistakes and unforeseen problems.

1.22 Discussion

This method might not be the most efficient way of replacing the motor and it is possible that an easier method could be developed. However, now there is a way to replace the motor compared to before when it was not possible without spending a fortune on a crane.

As time passes the amount of Wärtsilä power plants around the world rises and with it the number of roof ventilation units. Eventually a fan motor will burn and therefore it was important to get a solution for this. As long as Wärtsilä does not make any significant changes in the design of the roof ventilation units, this solution will work. Also, as the design is developed this solution can develop with it.

Neither of the devices designed nor the method of replacing the motor have been tested during the work on this thesis. Because of this there is for sure much that can be improved

and further developed. In chapter 5.4 some ideas that have been thought of are described, but due to lack of time they have not been further analysed.

1.23 Further Development

First of all the whole method should be tested and evaluated. If there are problems they are to be eliminated subsequently. In this process feedback from work sites is an important tool and is to be carefully gathered.

Also the instruction manual should be updated according to feedback. Some pictures of the devices in use would make it easier to understand the instructions. The manual could also be sent to a manual expert for pedagogical improvements.

When this method and these tools have been evaluated and perfected they could be adapted to fit old projects and other suppliers.

A risk assessment could be done to determine if there are any unforeseen risks. For instance when loosening the rotor from the motor one person has to lie under the fan. A Health, Safety and Environment document could be made based on the risk assessment and then be included in the instruction manual.

When designing new power plant projects the replacement of the motor should be taken into consideration so that hatches are added in the radiator platform specifically for the lifting of the motor. The position of the monorail on the radiator platform could also be taken into consideration in the design phase and also the radiator fan lifting wagon could be designed so it would be capable of lifting the fan motor.

The design of the base plate could be changed so the columns of the lifting device could be fastened with more than one bolt.

Bibliography

- [1] Jakobsson, Dan (Senior Development Engineer, Civil, Wärtsilä).
Personal Communication.
(Meeting 15 January 2013)
- [2] Ollus, Eija (Manager of Civil Engineers, Wärtsilä), Sandås, Markus (Development Manager, Civil, Wärtsilä), Nyman, Simon (Chief Project Engineer, Civil, Wärtsilä) and Jakobsson, Dan (Senior Development Engineer, Civil, Wärtsilä).
Personal Communication.
(Kick-off meeting 14 September 2012)
- [3] Wärtsilä.
<http://www.wartsila.com/en/about/company-management/overview>
(Retrieved 8 October 2012)
- [4] Wärtsilä.
<http://www.wartsila.com/en/power-plants/references>
(Retrieved 8 October 2012)
- [5] *DBAB319871_a. Flow Diagram Engine Hall, Kribi Gas Fired Power Plant.*
Wärtsilä Integrated Document Management (IDM). Wärtsilä Internal Document.
(Retrieved 25 January 2013)
- [6] *2V78C0408_e. Roof Monitor 32.*
CIWIS. Wärtsilä Internal Document.
(Retrieved 25 January 2013)
- [7] *DBAB003682_g. Roof fan 1400 low noise Standard drawing.*
CIWIS. Wärtsilä Internal Document.
(Retrieved 24 January 2013)
- [8] *DBAC428491. Pernambuco III Installation and Assembly Instructions Roof Fan 1400 – 30 m³/s.*
Wärtsilä Integrated Document Management (IDM). Wärtsilä Internal Document.
(Retrieved 25 January 2013)
- [9] *DBAB003679_h Roof fan 1400 ultra-low noise.*
CIWIS. Wärtsilä Internal Document.
(Retrieved 24 January 2013)
- [10] *DBAB292691_a. Roof Fan Ventilation, Kribi Gas Fired Power Plant.*
Wärtsilä Integrated Document Management (IDM). Wärtsilä Internal Document.
(Retrieved 25 January 2013)
- [11] *DBAB849822_-. Roof Fan 30m³/s, Sasolburg Gas Engines Power Plant.*
Wärtsilä Integrated Document Management (IDM). Wärtsilä Internal Document.
(Retrieved 25 January 2013)

- [12] Fläktwoods. *JM aksiaalipuhaltimet*. Online product catalogue. p.20.
<http://flaktwoods.fi/de74a2f3-6792-4def-8faa-144125f5c74d>
(Retrieved 25 January 2013)
- [13] Ziehl-Abegg (2011). *MAXvent 2 medium pressure axial fans with energy-saving IE2 motor 04/2011*. Online product catalogue. p.102-103.
<http://www.ziehl-abegg.com/sg/misc-168-Catalogue-Axial-fan-MAXvent-2.html>
(Retrieved 25 January 2013)
- [14] Fläktwoods Fan Selector
<http://fanselector.flaktwoods.com/>
(Retrieved 24 January 2013)
- [15] *DBAB822092_c. Power House Section, Sasolburg Gas Engines Power Plant*.
Wärtsilä Integrated Document Management (IDM). Wärtsilä Internal Document.
(Retrieved 25 January 2013)
- [16] *DBAB264250_g. Power House Section, Kribi Gas Fired Power Plant*.
Wärtsilä Integrated Document Management (IDM). Wärtsilä Internal Document.
(Retrieved 25 January 2013)
- [17] *DBAB261043_d. Master layout, Kribi Gas Fired Power Plant*.
Wärtsilä Integrated Document Management (IDM). Wärtsilä Internal Document.
(Retrieved 25 January 2013)
- [18] Nyman, Simon (Chief Project Engineer, Civil, Wärtsilä)
Personal Communication
(Meeting 23 January 2013)
- [19] *DBAB700021_f. Master layout, Sasolburg Gas Engines Power Plant*.
Wärtsilä Integrated Document Management (IDM). Wärtsilä Internal Document.
(Retrieved 25 January 2013)
- [20] *WDAAA382139. Manual trolley from 250 to 10.000kg*.
Wärtsilä Integrated Document Management (IDM). Wärtsilä Internal Document.
(Retrieved 25 January 2013)
- [21] *DBAA776967. Motor Lift Frame*.
Wärtsilä Integrated Document Management (IDM). Wärtsilä Internal Document.
(Retrieved 25 January 2013)
- [22] Gebr. Käufer GmbH Befahrtechnik.
<http://www.kaeufer.de/en/>
(Retrieved 21 September 2012)
- [23] Borg, Anders (Structural Engineer (MA), Novia University of Applied Sciences)
Personal Communication
(Meeting 17 January 2013)
- [24] SFS. (2005). *SFS-EN 10027-1:2005(E), Designation systems for steels – Part 1: Steel names*. Finnish Standards Association SFS. ICS: 77.080.20

- [25] DIN 931, *M1,6 to M39 Hexagon Cap Screws Partially Threaded - Product grades A and B*.
- [26] DIN 975 *Threaded rods*.
- [27] SFS. (2002). *SFS-EN 1990:2002(E), Eurocode. Basis of structural design*. Finnish Standards Association SFS. ICS: 91.010; 91.080.01; 92.090
- [28] SFS. (2002). *SFS-EN 1991-1-1:2002(E), Eurocode 1: Actions on structures. Part 1-1: General actions. Densities, self-weight, imposed loads for buildings*. Finnish Standards Association SFS. ICS: 91.010; 91.080.01; 92.091
- [29] SFS. (2005). *SFS-EN 1993-1-1:2005(E), Eurocode 3: Design of steel structures - Part 1-1: General rules and rules for buildings*. Finnish Standards Association SFS. ICS: 91.010; 91.080.10; 92.093
- [30] SFS. (2005). *SFS-EN 1993-1-8:2005(E), Eurocode 3: Design of steel structures - Part 1-8: Design of joints*. Finnish Standards Association SFS. ICS: 91.010; 91.080.10; 92.093
- [31] SFS. (2005). *SFS-ENV 1993-1-1:1992, Eurocode 3: Design of steel structures - Part 1-1: General rules and rules for buildings*. Finnish Standards Association
- [32] Ongelin, P & Valkonen, I. (2010) *Hitsatut profiilit EN 1993 –käsikirja*. (3rd edition). Keuruu: Otavan Kirhapaino Oy. ISBN 978-952-5010-02-2.
- [33] Andersson, J., Lind, J-E., Hagnäs, L., Käcklund, J-A., Östman, L. & Eriksson L. (2007). *Byggnadskalendern 2008*. Ekenäs: Ekenäs Tryckeri AB. ISSN 0357-427X
- [34] SKF. Online product table.
<http://www.skf.com/group/products/bearings-units-housings/ball-bearings/deep-groove-ball-bearings/single-row/index.html>
 (Retrieved 14 January 2013)
- [35] SKF. Online product table.
<http://www.skf.com/group/products/bearings-units-housings/ball-bearings/thrust-ball-bearings/single-direction/index.html>
 (Retrieved 14 January 2013)
- [36] Nyman, Simon (Chief Project Engineer, Civil, Wärtsilä), Jakobsson, Dan (Senior Development Engineer, Civil, Wärtsilä) and Borg, Anders (Structural Engineer (MA), Nova University of Applied Sciences)
 Personal Communication
 (Meeting 12 October 2012)
- [37] Rautava Vesa. vesa.rautava@energent.fi, 2013. *VS: Roof fan motor replacement instructions*. [Email] Message to: Ivar Gullström ivar.gullstrom@wartsila.com. Sent on Wednesday 23 January 2013, 13:21. [Accessed 23.01.2013].

[38] *DBAB697292, Sasolburg_17042012. Naviswork 3d model.*
Wärtsilä Integrated Document Management (IDM). Wärtsilä Internal Document.
(Retrieved 25 January 2013)

Appendices

Appendix A: Standard Drawings of Roof Ventilation Unit

- A1 *Low Noise*
- A2 *Ultra-low Noise*

Appendix B: Calculations

Robot Calculations

- B1 *Lifting Device: Beam, Brace and Columns*
- B2 *Sliding Device: Beam*

Manual Calculations

- B3 *Lifting Device: Connection between Beam and Column*
- B4 *Lifting Device: Connection between Brace and Column*
- B5 *Lifting Device: Lifting Mechanism*
- B6 *Flange of the Fan*
- B7 *Sliding Device: Lateral Buckling of Beam*
- B8 *Sliding Device: Sliding Table*
- B9 *Flange of the Base Plate*
- B10 *Lifting Lug*

Appendix C: Drawings

- C1 *Lifting Device: Assembly Drawing*
- C2 *Lifting Device: Manufacturing Drawing Column 1*
- C3 *Lifting Device: Manufacturing Drawing Column 2*
- C4 *Lifting Device: Manufacturing Drawing Brace*
- C5 *Lifting Device: Manufacturing Drawing Beam*
- C6 *Lifting Device: Manufacturing Drawing Lifting Mechanism*
- C7 *Sliding Device: Assembly Drawing*
- C8 *Sliding Device: Manufacturing Drawing Beam*
- C9 *Sliding Device: Manufacturing Drawing Sliding Table*
- C10 *Lifting Lug: Manufacturing Drawing*

Appendix D: Instruction manual

NOTE! *In the official version of this thesis the appendices are excluded due to confidentiality.*