



SAVONIA

Planning Annual Shutdown Inspection for BFB Boiler

Tatu Sorsa

Bachelor's Thesis

Bachelor's degree (UAS)

Field of Study Technology, Communication and Transport			
Degree Programme Degree Programme in Energy Technology			
Author(s) Tatu Sorsa			
Title of Thesis Planning Annual Shutdown Inspection for BFB Boiler			
Date	12.5.2014	Pages/Appendices	39/1
Supervisor(s) Senior Lecturer Seppo Rynänen			
Client Organisation/Partners Andritz Oy, Varkaus, Finland			
<p>Abstract</p> <p>The goal of this thesis was to create an illustrative guidebook of annual inspection planning for BFB boiler to help power plant operator when planning of annual inspection is topical. This thesis was made for Andritz Oy and it is based on inspection reports and experiences of BFB boiler's maintenance and inspection staff. In this thesis it is shown how to plan an annual inspection for BFB boiler and thesis gives good tools and hints for operator to manage inspection from the beginning of planning all the way to the next shutdown.</p> <p>The main operating area of Andritz Oy in Varkaus is planning of Power boiler plants and service in Pulp and Paper industry but also in renewable fuels. In the renewable fuels BFB boiler has become more and more popular type of boiler family within the years and BFB boiler is operating and maintenance may be a little bit unfamiliar for operator of the power plant and therefore this inspection planning guide is very important.</p> <p>In the inspection planning guide there are a lot of qualities and illustrative pictures from real cases from the field like: pictures of corrosion and erosion on the heater pipes, sample pictures of fouled and eroded heater tubes etc. However inspection guide is confidential and only for the use of Andritz. Therefore inspection planning guide is not attached in this thesis.</p>			
<p>Keywords Bubbling fluidized bed, Annual shutdown inspection, Maintenance, Andritz Oy</p>			

ABBREVIATIONS AND USED SYMBOLS

BFB = Bubbling Fluidized Bed

BTU = British Thermal Unit (1 BTU = 1055 joules)

DCS = Distributed Control System

DT = Destructive Testing

ECO = Economizer (Feed water preheater)

ESP = Electrostatic Precipitator

FBC = Fluidized Bed Combustion

IEA = International Energy Association

IPCC = Intergovernmental Panel on Climate Change

LUVVO = Combustion air preheater (Luftvorwärmer)

MFB = Multi Fuel Boiler

NDT = Non Destructive Testing

RDF = Refuse-Derived Fuel (household waste and reject)

SRS = Safety Related System

UNEP = United Nations Environment Programme

WHO = World Health Organization

FOREWORD

I would like to thank all people of UAS Savonia. Special thanks go to supervisors Seppo Rynänen and Jarmo Pyysalo for helping me with this thesis and teacher Satu Huusari for checking the language.

Thanks for Andritz Oy personnel of support and opportunity to participate in field journey in Lieksa and the shutdown inspection journey in Huelva, Spain 22-29.4.2014. Special thanks go to Ari Korpirinne and Antti Pulkka for providing the opportunity to do this thesis. Thanks to Timo Hynynen, Harri Pitkänen, Antti Oksman and Yolanda Gonzales for great co-operation and guiding during the shutdown inspection journey. Special thanks go also Kalle Aro for guiding during Lieksa measuring journey.

I would also thank my parents, brothers, fiancée Katariina and friends for supporting me during my studies and understanding during the thesis process.

TABLE OF CONTENTS

ABBREVIATIONS AND USED SYMBOLS	4
FOREWORD	5
TABLE OF CONTENTS	6
1. INTRODUCTION	8
1.1 IMPLEMENTATION METHOD	8
2. ANDRITZ OY	9
3. THE WORLD'S ENERGY SITUATION	11
3.1 FOSSIL FUEL	12
3.2 RENEWABLE FUEL.....	12
3.3 EMISSIONS.....	13
4. COMBUSTION TECHNOLOGY FOR ENERGY PRODUCTION.....	14
5. FLUIDIZED BED COMBUSTION	15
6. BUBBLING FLUIDIZED BED	16
6.1 BFB BOILER PARTS	17
6.1.1 BOILER ´S INNER PARTS	18
6.1.2 BOILER ´S EXTERNAL PARTS	18
6.1.3 AUXILIARIES.....	19
6.2 COMBUSTION	20
6.3 FUEL.....	20
6.4 EMISSION CONTROL.....	21
7. BOILER ´S ANNUAL SHUTDOWN	22
8. BFB BOILER ´S INSPECTIONS AND MAINTENANCE DURING SHUTDOWN	23
8.1 PLANNING OF INSPECTION	23
8.2 PROBLEM TYPES AND CAUSE OF THE FAILURES	23
8.3 BOILER ´S WEARING MECHANISMS	24
8.3.1 CORROSION & EROSION.....	24
8.3.2 METAL FATIGUE.....	25
8.3.3 OVERHEATING	26
8.3.4 FOULING.....	26
8.3.5 SLAGGING.....	27
8.4 INSPECTION METHODS	27
8.4.1 VISUAL INSPECTION.....	28
8.4.2 NDT-INSPECTION.....	28
8.4.3 DT-INSPECTION	28

8.5 MEASURING DEVICES.....	29
8.5.1 FLOW METERS.....	29
8.5.2 LEVEL METERS	31
8.5.3 TEMPERATURE METERS	32
8.5.4 DENSITY METER	34
8.5.5 PRESSURE-AND PRESSURE-DIFFERENCE METERS	34
8.5.6 WALL THICKNESS METERS	34
8.6 AUTOMATION	35
8.6.1 SRS.....	35
8.6.2 DCS-SYSTEM	35
8.7 LEGISLATION OF INSPECTION	36
9. CONCLUSIONS	37
REFERENCES	38
APPENDICES.....	40

1. INTRODUCTION

Maintenance repairs and inspections of power boiler are in key role to keep power plant running smoothly and energy-efficiently. Without well-organized maintenance repairs and continuous condition monitoring, plant life cycle would be shorter and risk of material and/or personal injury would be more potential.

This thesis introduces an easily legible annual inspection guide for Bubbling fluidized bed boiler. This thesis serves and supports power plant operators to plan and supervise annual inspections of BFB boilers. Inspection guide covers maintenance instructions of Andritz manufactured/delivered parts like: Visual and NDT-Inspection of boiler and its inner parts, ash discharging systems with conveyors, air and fuel feeding systems with conveyors, air ducts and flue gas handling system. Shortly: inspection of all parts from inlet air intake to end of the stack is introduced in this guide.

Because every delivered power plant is tailor-made complex this thesis handles inspections in common way and thus can't be followed directly but the main inspection principle and wearing mechanisms are still the same for all boiler constructions.

1.1 IMPLEMENTATION METHOD

This thesis is based on previous inspection reports of the different type boilers (BFB-, CFB- and Soda boiler) and field experience of boiler flue gas temperature measuring inside the boiler in Lieksa and shutdown inspection in Huelva Spain.

Boilers from old design and long served to the one utilizing the most advanced technology which have been carried out first annual shutdown inspection and maintenance have also been taken into account. This thesis is also based on different kind of reports from boiler failures and incidents.

2. ANDRITZ OY

Andritz was established in 1852 in Austria by Josef Körösi and headquarter are located in Graz. Name Andritz comes of Graz town neighbourhood named Andritz. Andritz-group employed approx. 3700 persons worldwide at end of the year 2013 (Andritz company presentation February 2014).



Picture 1. Company logo

Andritz AG consists of four different sections: Andritz Hydro with 35-40%*, Andritz Pulp & Paper with 25-30%*, Andritz Metals with 25%* and Andritz Separation with 10%*.

* Average share of Andritz group's total order intake in 2014

As seen The biggest part of the Andritz turnover takes Andritz Hydro with 35-40% of total order intake. Andritz has also hydropower know-how in Finland via Andritz Hydro Oy which was formed on basis of Oy Tamturbine Ab in Tampere.

Andritz Oy is formed from two old Finnish engineering works companies Kone Wood Oy and Ahlstrom Machinery Oy that Andritz AG bought in years 1994 and 2000-01. Andritz Oy employs approx. 900 persons in Finland and its turnover was around 600 million € in 2014 (Andritz news report, Helsinki 17.2.2014)

Andritz Oy's main product in Varkaus is pulp and paper mill power plants and power plant auxiliary design, service, modernization and upgrades. ECOFLUID and POWERFLUID fluidized bed boiler and for pulp and paper mill soda liquor boiler SODEX are the main subdivisions of the product range.

Andritz Oy owned half of the engineering workshop of Warkaus Works with competitor Foster Wheeler from the year 2000. Andritz bought FW's share of the Warkaus Works in year 2014 and now owns 100% share of the company.

Warkaus Works produces soda- and power boiler parts in Varkaus and it has a long history in the engineering workshop industry in Finland. Major parts of the products are exported all over the world and used in power plants designed by Andritz.

Presented in this thesis BFB-Boilers produced by Andritz are located all around the world and there are 54 BFB-Boilers operating at the moment with total fuel input power of 3119.4 MW

The most important customers of Andritz come from pulp and power industry and in the same area operate The main competitors of Andritz: Metso, Foster Wheeler, Babcock&Wilcox, and Valmet.

Andritz's field of expertise and production range of power plant are shown inside the red circle in picture 2.

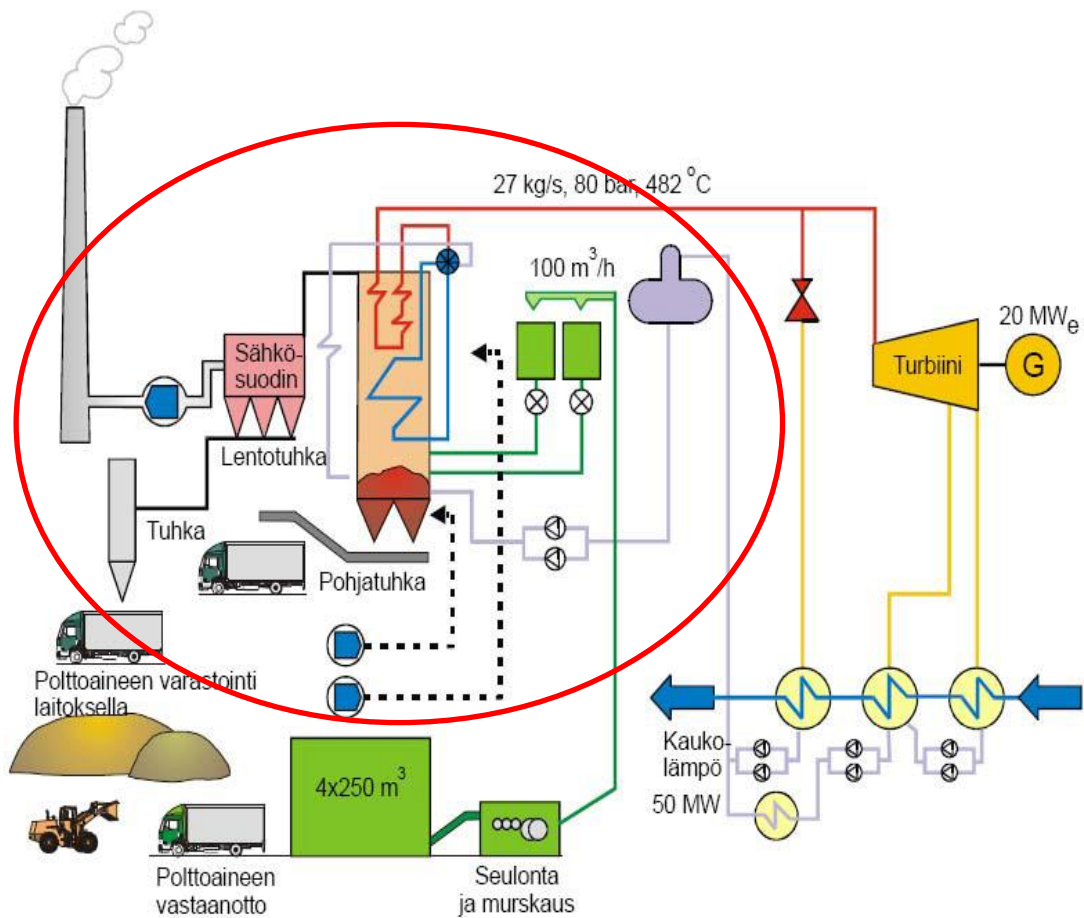

Voimalaitoksen prosessikaavio.

Picture 2. Power plant process.

3. THE WORLD'S ENERGY SITUATION

The World's energy need keeps growing and growing like can be seen in Picture 3. In the meanwhile climate change melts more and more ice layers of the North and South poles and fries deserts of the Earth. Using a fossil fuel to correspond to the world's energy need is no longer as good an option as it was seen for example a half century ago. Renewable energy increases its popularity day after day and it is now seen as a trendy and modern way to produce energy and reduce greenhouse gas emissions.

Nuclear power and fossil fuel driven power plants are no more in favor whereas bio-fuel-, refuel-, sun-, wind and hydro power plants begin to take the lead in the future power plant domination. With these it is hoped that energy production solution CO2 emissions and temperature rising can be kept steady.

CO2 is one of the major greenhouse gases and it is aimed at controlling when meeting the climate change target of +2 degrees of average global temperature rise in 22st. century (based on UNEP and IEA, Report, published 2012).

Figure 16. World energy consumption by fuel type, 1990-2040

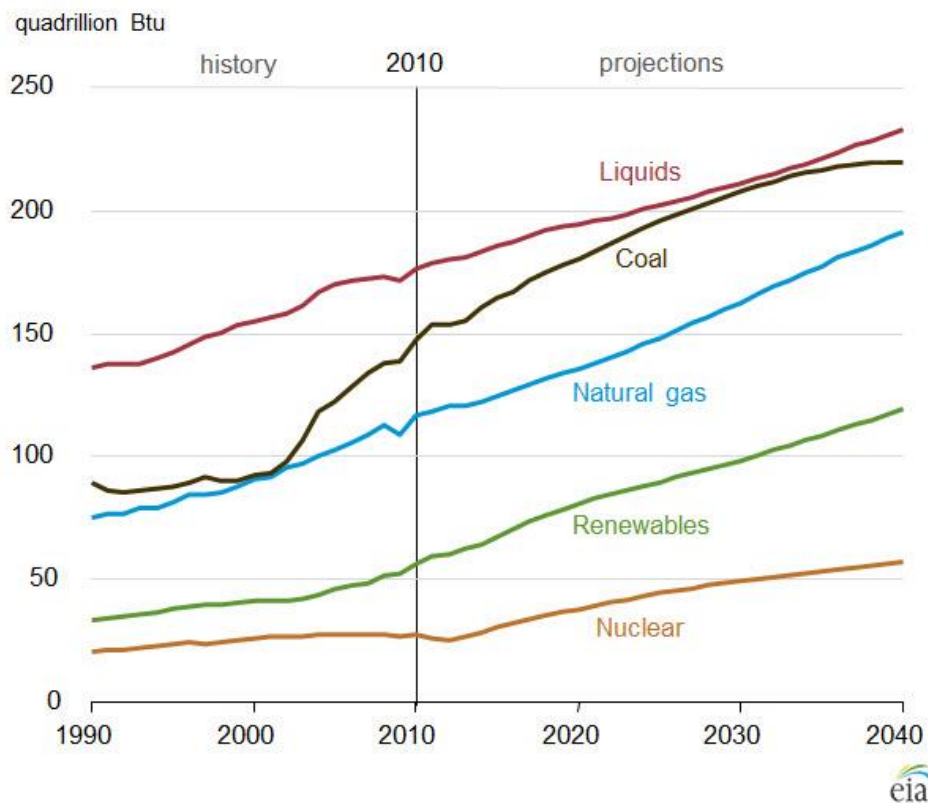

Picture 3. World's energy consumption by fuel type [Attached 10.3.2014]

3.1 FOSSIL FUEL

Fossil fuels: Carbon-based fuels from fossil hydrocarbon deposits, including coal, peat, oil and natural gas (IPCC, 2007: Climate change 2007: Mitigation).

Fossil fuel was formed a very long time ago of dead and buried organs anaerobic decomposition. Organs way from death to fossil fuel takes over several million years. Fossil fuels have only few good features which are energy content, cheap price and availability (it is no longer so clear how many years we have fossil fuel left to burn). The burning of fossil fuels is the major reason for growing temperature and greenhouse effect. Fossil fuels contain a lot of carbon and it is released to the atmosphere as carbon dioxide CO₂ when burned.

Typical fossil fuels are:

- Coal
- Oil
- Natural gas
- Peat (can be considered as a slowly renewable fossil fuel*).

* Peat's category between fossil fuel and renewable fuel is controversial. Peat need about 10 000 years to form and it can be also considered as a slowly renewable fuel.

3.2 RENEWABLE FUEL

Fossil fuel's price is growing, reduction of CO₂ emissions is needed and energy resources are running out so the need of alternative energy production is more than an important role in future energy production.

The main concern however is global warming and how to control the growing average temperature. That goal can be reached by substituting fossil fuels by renewable fuels and energy.

Renewable fuels are a way to cleaner air and slowing down climate change.

Renewable fuel's circulation time is low and it is a healthy way to produce cleaner energy without extra greenhouse gases.

Typical renewable fuels:

- Oils from organic sources like: eucalyptus oil, palm oil, produced of algae oil, rape seed oil etc.
- Energy crops like: red canary grass, energy willow, corn etc.

- Woods like: pine, eucalyptus, palm tree, sawdust, wood waste etc.
- Peat (renewable or not, depends on point of view)
- Sludge from different kind of process in example from paper mills.

Some missteps can easily be taken when renewable fuel is taking place in the energy market like growing of edible food for fuel purpose due to better income while people are starving nearby creates ethical issues. This kind of problems come up when competition with cheaper fossil fuel keeps getting tougher and the source of renewable fossil fuel is not taken account enough.

3.3 EMISSIONS

Emission control is the key word around the world at this time. Big cities like Peking in China have had problems with air pollution for a long time. In Peking there are recommendations for staying inside during the most polluted time.

In 2010 China was the biggest CO₂ producer with 31 350 455 thousands of tons of annual CO₂ emission which responses to 26.43 % of all CO₂ emission in the world.*

* http://en.wikipedia.org/wiki/List_of_countries_by_carbon_dioxide_emissions

Peking's main producers of pollution with traffic are power plants. The main concern is fine particles which are less than 2.5 micrometres in diameter.

These particles cause harm like breathing problems and even cancer when build up in lungs. Level of the particles in the air can be followed in live. For example live monitoring from Peking air quality can be seen at: <http://aqicn.org/city/beijing/>

Even in France the air quality was reported to be very poor in 18th of March. The main reason of low air quality in Paris was traffic (France favour diesel powered cars).

*(BBC news on 18 March 2014)

On 25th March 2014 WHO told in its report that now air pollution is the world's largest single environmental health risk. WHO estimates that in year 2012 around 7 million people have died as a result of air pollution exposure, so for that we must take some real actions. Emissions are the biggest question of the energy production and that can't be denied.

4. COMBUSTION TECHNOLOGY FOR ENERGY PRODUCTION

Over the years combustion has been the main source of energy. The natives found a way to cook food and stay warm with fire. A little bit later someone invented that fire can be used to travel from place to another and today people use fire almost every day even without noticing it.

In the present time the way of exploit combustion for energy production has evolved a lot. We use fuel burning boilers that produce heat water for smaller like household use and bigger boilers which produce saturated steam to generate district heat and electricity of the whole city. A modern BFB type boiler which can be run with almost all burning material from biomass to community waste can be seen in picture 4.



Picture 4. BFB Boiler combustion

5. FLUIDIZED BED COMBUSTION

There are three FBC types: **Fixed bed (FB)** where bed material doesn't flow at all, **Bubbling fluidized bed (BFB)** where bed material floats an approx. 1m thick layer above the grid and **Circulating fluidized bed (CFB)** where primary air velocity is high and this makes bed material circulating in the system. Bed material is separated from flue gas with cyclone and returned back to the bed.

Different kinds of fluidized bed combustion systems are presented in picture 5.

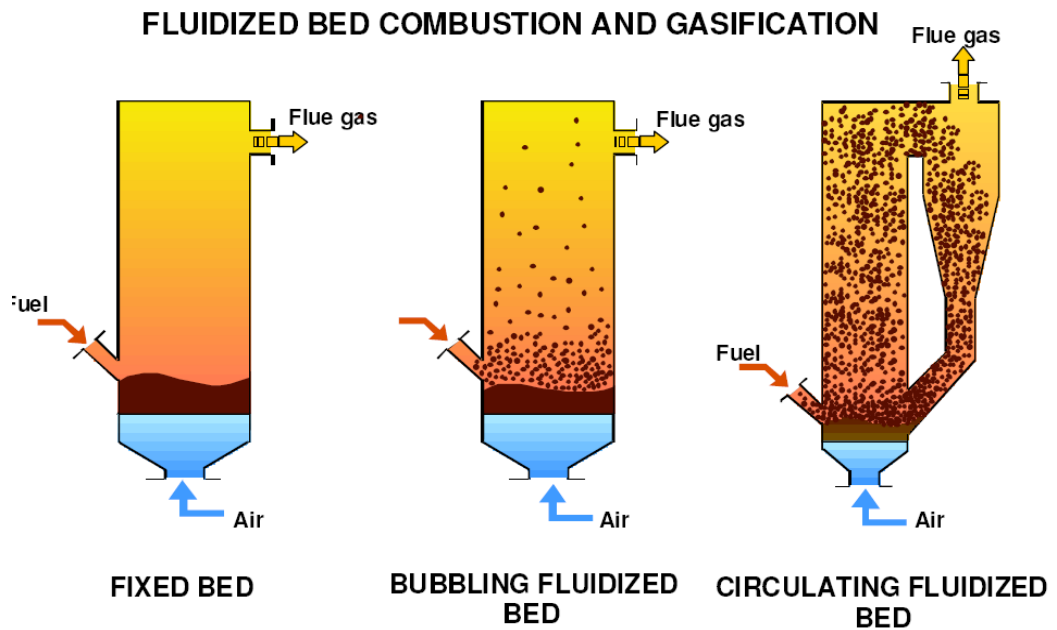

Picture 5. Fluidized bed types

In the picture 5 fluidizing air speed grows from right to the left which makes bed material fluidize higher and eventually circulate like in CFB type boiler.

Manufacturer's differences between boilers are commonly: furnace floor, fuel feeding system and general boiler arrangement. All manufacturers have made their own looking type of the boiler but the main principle of all BFB boilers is still the same.

6. BUBBLING FLUIDIZED BED

Bubbling fluidized burning technology is simple and energy efficient way to produce energy with low investment and maintenance cost. Boiler's simple operating principle causes less problems and unexpected shutdowns as for example CFB or soda boiler technique. BFB boiler is also easier to build and causes minor visual environmental issues than other boiler types thanks to its more delicate outfit.

Bubbling fluidized bed consists of approx. 1m thick layer of fluidized bed material (usually sand and ash) and it is fluidized by primary air which is sprayed to the boiler through the furnace. Fuel is fed straight into the bed via fuel feeding chutes. Fuel volatiles and volatilized gases burn above the bed where secondary air is sprayed.

Bubbling fluidized bed technology was introduced for the first time in 1960 and in that time the used fuel was mainly peat and bark. Nowadays BFB technology can handle more difficult fuels and fuel combinations like community waste and sludge.

Bubbling fluidized bed combustion technology is ideal for high volatile materials like biomass and alternative fuels like wood chips, sawdust, bark, sludge and so on and technology is used usually in average sized CHP-plants for its flexibility of load changes. BFB Boiler can be driven by constant load between 30-100% and it corresponds fast to energy need variation and that is the one big advantage of the BFB boiler.

Andritz provides bubbling fluidized bed boiler in range 50-400 ton/h of steam production. *(XT Training Vierumäki Finland, Pulp Engineered Services Division) and the biggest BFB Boiler at this time is located in Virginia, USA with 210 MW of fuel input power, it is built in 2011 and it use Wood, Sludge and Natural Gas as a fuel. *(Andritz reference list 2013)

6.1 BFB BOILER PARTS

During the annual shutdown inspection the following listed section shown in picture 6 is especially under surveillance.

All alarming observations should be taken into account very strictly and potential failure option should be resolved.

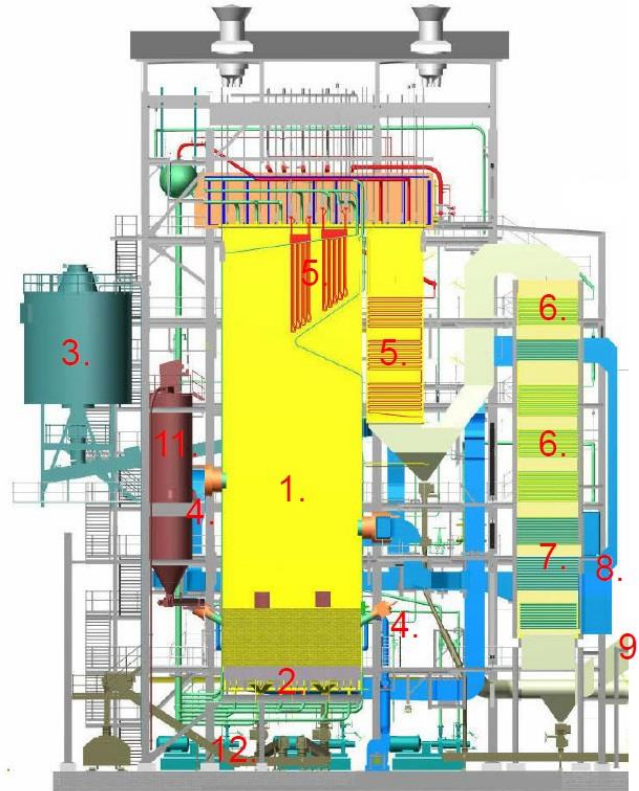

Picture 6. Main parts of the BFB Boiler

1. Bubbling fluidized bed furnace
2. Fluidization grid
3. Solid fuel feeding system (conveyors, feeders etc.)
4. Oil/gas firing system (start-up and load burners)
5. Superheaters
6. Economizers
7. Flue gas air preheaters
8. Air system
9. Flue gas system
10. Flue gas recycling system (invisible in this picture but located in section 9)
11. Sand dosing system
12. Bottom ash system
13. Fly ash system

6.1.1 BOILER 'S INNER PARTS

Parts located inside the boiler are continuously affected by high temperature, corrosive gases, high flue gas velocities and flow of bed material. These cases cause different kind of wearing like erosion and corrosion of the boiler's inner parts and therefore wearing of the parts must be followed constantly as strictly as possible.

Below is the list of inner parts which need most attention:

- Furnace grid inspection for sintered bed material and worn air nozzles.
- Furnace heat transfer tubes (wall tubes, superheaters, second pass walls and evaporator) must be inspected. Especially tube corners and bends must be inspected for erosion and corrosion and thickness measurements must be taken for monitoring wearing.
- Refractories condition (furnace openings like air ports, fuel feeding opening, man doors).
- Boiler suspension rods
- Sootblowers condition.
- Measuring instruments condition.
- Economizer

6.1.2 BOILER 'S EXTERNAL PARTS

The wearing of boiler's external parts is quite the same as with inner parts even though they have been installed in a bit better circumstances than inner parts.

The condition of the boiler's external parts can be inspected also during the operation what makes inspection of these parts very easy.

Below is a list of main objects of the external parts:

- Feed water tank
- Deaerator
- Sight glasses inspections for smoked or cracked sight glass.
- Steam drum
- Main steam line and valves
- Blow-down pipes and silencer condition
- Blow-down and continuous blow-down tank

6.1.3 AUXILIARIES

Auxiliaries are usually installed separately from but anyway they are still important parts of the boiler operation and therefore cannot be forgotten when it comes to inspection and maintenance.

In the picture 7. it can be seen the overall layout of the boiler's outer equipment.

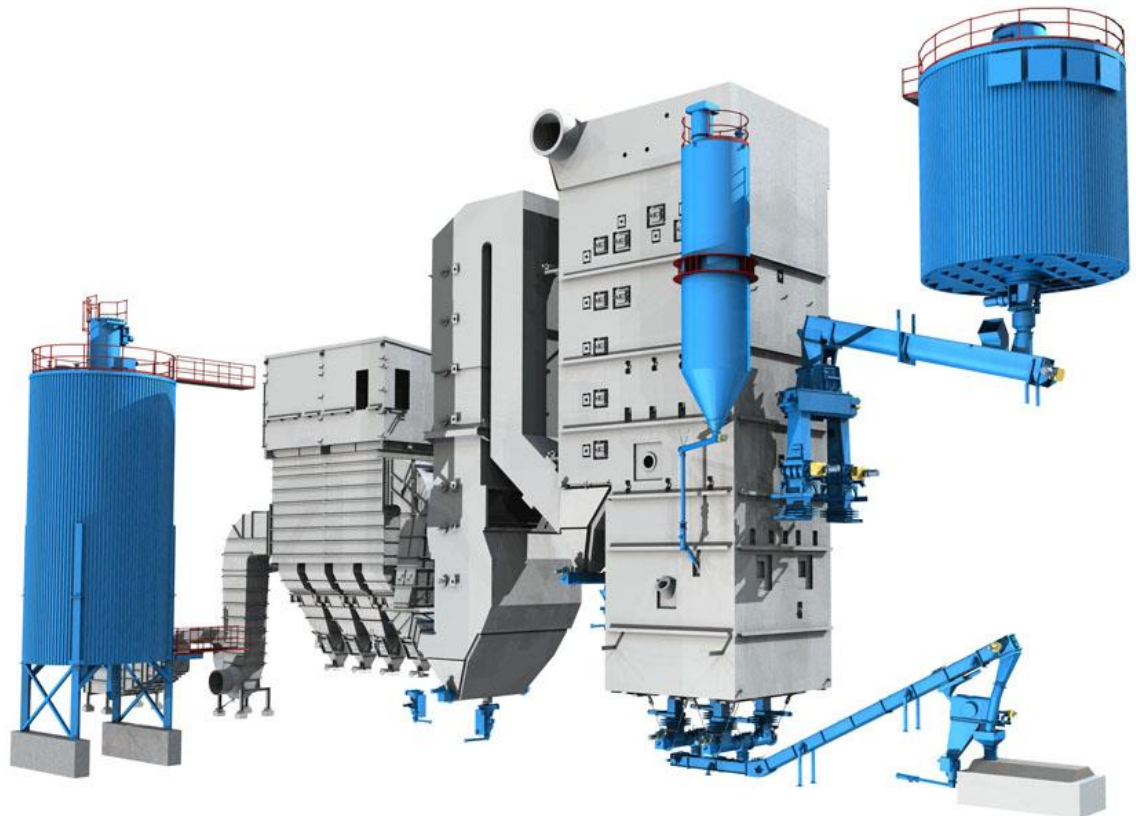

Picture 7. Andritz material handling inside the boiler house.

Boiler's main auxiliaries:

- Feed water pumps
- Start-up and load burners
- Combustion air feeding system (Air fans, -chutes, wind box and LUVU).
- Flue gas system (Fans, chutes, dampers, filters, ECO, LUVU and stack).
- Conveyors (Fuel feeding and ash discharging conveyor systems).
- Fuel and ash silos plus equipment like filters.
- Insulation
- SRS-System

6.2 COMBUSTION

Bubbling fluidized bed operation is based on gasifying the high volatile content fuels and combustion of the volatiles. Fluidized bed material (usually sand and ash which is fluidized by the primary air blasted through the grate) stores a huge amount of heat energy and therefore combustion reaction is very stable despite of moisture concentrate and energy content fluctuations of the fuel. Fuel is inserted straight into the bed material where it dries and gasifies. Gassed gases are burned mainly over the bed and the released heat energy heats water inside wall tubes of the furnace.

Fluidized bed is about 1 m high and bed material's particle size is usually 0.5 – 2 mm. Fluidization velocity in BFB-type boiler is between 0.8 to 1.5 m/s.

It is important to keep the bed temperature inside the directions (less than 750 °C) otherwise too high bed temperature causes sintering of bed material and problems with air nozzles at the bottom of the grate by obstructing them.

6.3 FUEL

BFB technology is ideal for high volatile fuels like wood, sludge, organic waste and so on.

Fuel needs to be in little pieces (particle size around 2 cm to be little enough for fluctuation).

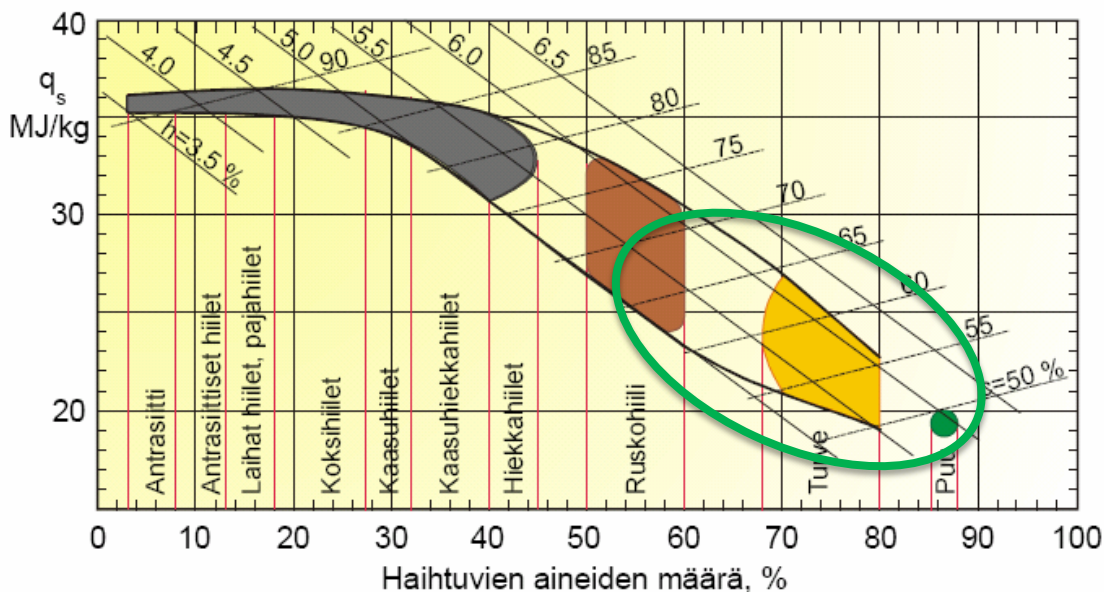

Lähde: Tekniikan käsikirja 2

Picture 8. Fuel energy and volatile material content

Picture 8. Are presents a volatile material percentage of different fuels and Green zone is suitable area for BFB Boiler.

Volatile material content can be seen at horizontal axle and energy content in vertical axle, black area contains different coal types, brown section is brown coal, yellow means peat and green dot is wood.

In some cases coal can be inserted in the furnace as a lean mixture (<20 %) with other fuel for example with peat.

Example of Wood's composition:

Ash: 0.4-0.6%*

Fixed coal: 11.4-15.6%*

Volatile materials: 84-88%*

Water: 8-60% depending on wood type, from compressed wood 8% of moisture to bark or fresh wood 60% of moisture.

* Share of solid material

6.4 EMISSION CONTROL

BFB boiler emissions are pretty low compared to other types of combustion technology, due to efficient mixing of fuel and air. Emissions are still strictly dependent on used fuel and active flue gas filtration system (particle emission control equipment like ESP- or bag filter and optional ammonia feeding system SNCR DeNO_x).

ESP: Electrostatic precipitator separates finest particles from the flue gas with high voltage.

Cleaning process is simple: high voltage ionizes the gas around the electrodes and charges particles of the flue gas. Charged particles are attracted to the negative charged surface and then shaken off.

BAG FILTER: Bag filter filters particles in the same way as an ordinary vacuum cleaner filter. Bag filter is reliable and cheap filtration system of the flue gas but it is not as efficient as ESP.

7. BOILER 'S ANNUAL SHUTDOWN

For efficiency and long serving time boiler needs to be inspected annually and maintenance should be performed in time. Annual shutdown is also a good opportunity to clean boiler parts from inside.

Manufacturer's requirement is that boiler has one shut down per year. During that shutdown inspection and maintenance repairs that can't be done when boiler is running can be executed. These kinds of inspections are for example cleaning of furnace heat transfer pipes surfaces, measuring of furnace pipe material thickness and testing of SRS. During the annual shutdown inspections required legislation for authority determined person(s) need also to be executed.

Average duration of the basic annual shutdown is around one week. Shutdown time depends on boiler condition, planned maintenance and age of the boiler.

Planning of the shutdown should be started as early as 6 months before execution of inspection and all spare parts which are known that are required in future shutdown should be ordered on time before shutdown.

8. BFB BOILER 'S INSPECTIONS AND MAINTENANCE DURING SHUTDOWN

During the annual shutdown every observation of the inspection must be written down on a log book so that wearing of boiler parts can be monitored and preparation for next annual shutdown is easier.

Inspections start by reading previous inspection report where previous observations of inspection can be seen and maintenance of the boiler can be planned.

8.1 PLANNING OF INSPECTION

Planning of the annual shutdown inspection and time schedule are the key role for fluent and efficient shutdown inspection! A lot of money and time can be saved with carefully planned inspection.

Planning of the inspection must be started in good time before inspection and timing with good timetable is the main part of the whole inspection process.

While planning of inspection operator must take into account the operation of the boiler, for example problems during normal running can be sign of need of further or wider inspection and maintenance.

8.2 PROBLEM TYPES AND CAUSE OF THE FAILURES

There can be a countless number of problem types of the boiler and whole plant.

Main problems are usually caused when some part is worn or soiled and are not seen early enough and part fails for that. To prevent this kind of failures and operation problems maintenance and continuous monitoring of the part wearing is good to be arranged. Some examples are blockages of electric-motors cooling grid which cause overheating of the motor or different kind of conveyor problems which cause blockages and for example fuel feeding problems.

Corrosion, erosion, fouling and slagging is major cause for the problems of the boiler inner parts. More of these wearing methods are presented in the following section (section 8.3).

8.3 BOILER 'S WEARING MECHANISMS

Wearing of the boiler parts is normal and it cannot be totally prevented.

In the boiler there is heat variation, corrosive flue gases and abrasive bed material flow which cause corrosion and erosion of the boiler parts.

Different kinds of tube shields are assembled to protect tubes in critical wearing areas like bends and tubes at the high gas velocity areas. Tube shields need to be replaced during the shutdown if they are worn out.

8.3.1 CORROSION & EROSION

Erosion is one of the major wearing mechanisms of the BFB boiler. Erosion is caused by bed material and ash which is fluidized with fuel on the grate. It can be compared to continuous sandblasting of the boiler tubes and other inner parts.

In the lower part of the furnace where fluidization takes place wall tubes are covered with refractories to protect piping from erosion.

Corrosion is another major wearing mechanism of the boiler parts. Corrosion depends on the used fuel's chemistry and temperature of the part; together these things can cause very good conditions for corrosion of the boiler parts.

Corrosion in the furnace:

Oxidizing conditions, melted ash and low temperature molten state remains compounds like: PbCl_2 , ZnCl_2 , and SnCl_2 etc. cause corrosion in the furnace.

Hot corrosion of the superheaters:

High temperature in the superheater part of the furnace causes hot corrosion of the tubes. In addition there is chlorine as well.

Picture9. represent formations of hot corrosion of the heat transfer tubes.

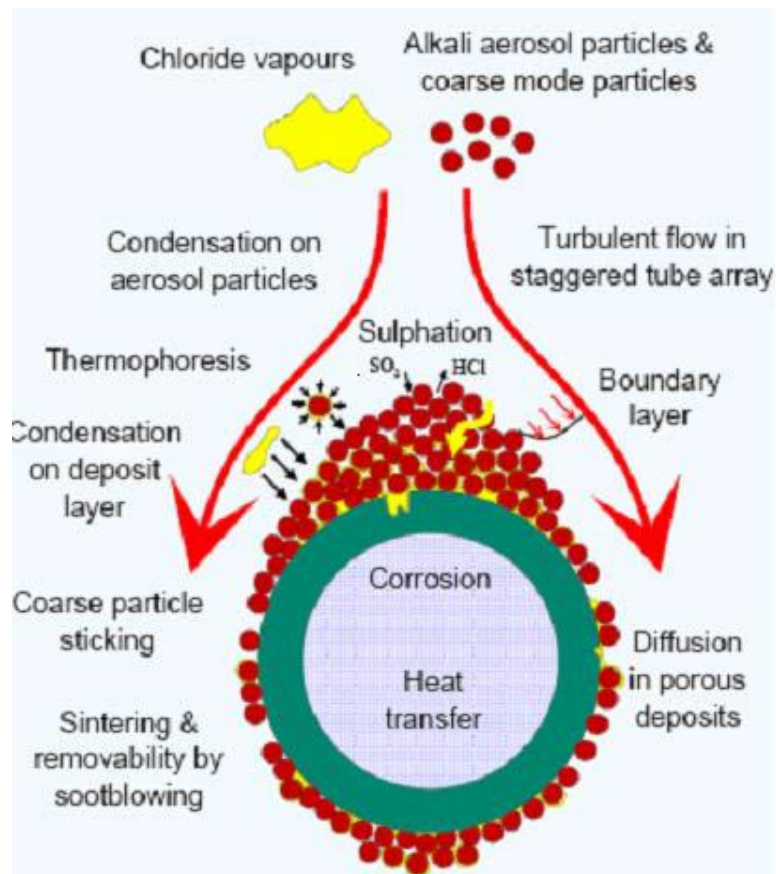

Picture 9. Corrosion of the heat transfer tube

Low heat corrosion:

In case of too low flue gas temperature in the last heat surfaces of the boiler system like economizer area, there is mainly shown the acid dew point and it causes corrosion of the parts. Here corrosion is mainly caused by fuel's sulfur and chlorine content.

8.3.2 METAL FATIGUE

When stress variations fall upon on metal part in long term metal fatigues.

Corrosion caused by stress variation can be divided into two sub-categories: mechanical and thermal corrosion.

Cyclic load variations develop microscopic cracks that grow bigger and when material withstand no more it breaks. This kind of failure can be find out with penetrant liquid or magnetic particle test.

8.3.3 OVERHEATING

Overheating is one of major cause of corrosion. Overheating of the part may occur mainly when starting process of the boiler or boiler shutdown process is incorrect.

Superheaters and heat transfer pipes in the second pass are most sensitive for overheating.

Overheating can be prevented by using homogenous fuel and following manufacturers operating guide for startups and shutdowns.

8.3.4 FOULING

Fouling occurs in the tubes, it decreases heat transfer capacity and therefore reduces efficiency of the boiler.

Fouling is caused by Fuel K, Na and ash contents plus ash Si content. In the picture 10. it can be seen how fouling forms a thick layer in heater tubes and weakens the heat transfer capacity. For preventing fouling sootblowers have been assembled in the boiler and formation of fouling can be sign of broken sootblowing system in that area.



Picture 10. Fouled heat transfer tubes

8.3.5 SLAGGING

Slagging occurs mainly on the walls of the furnace, it causes heat transfer problems in the same way as fouling and therefore it is harmful for the efficiency of the boiler and complicates inspections.

Slagging for example can be seen in Picture22.

Slag formation consists of molten ash and bed sand that is caught on the heat transfer surface in the hot part of the furnace.

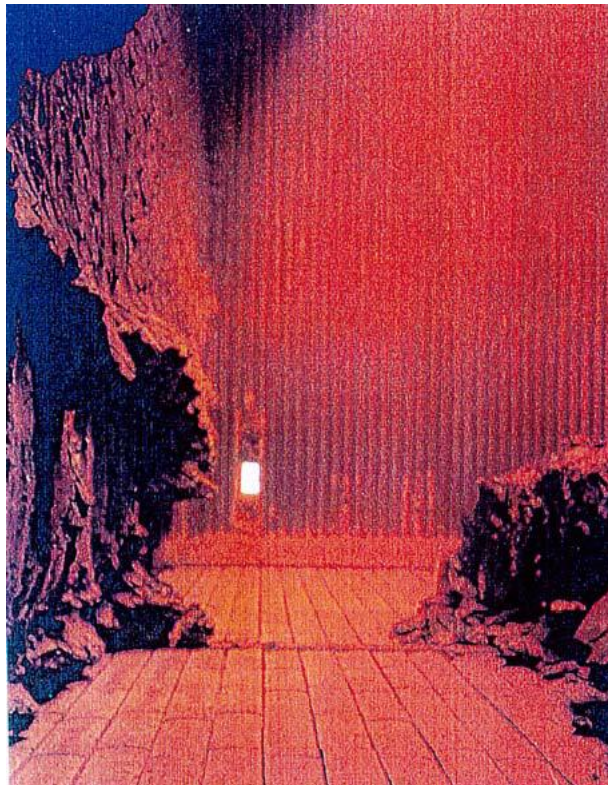

Picture 22. Slag formation on the furnace wall

8.4 INSPECTION METHODS

There are many inspection methods of the boiler parts. Some of them require cleaning of the inspection area to ensure the correct measuring results. Cleaning is important when for example heater tube's wall thickness needs to be measured.

Next sub-sections handle main inspection methods which are usually used in boiler inspections.

8.4.1 VISUAL INSPECTION

Visual inspection of the boiler and its parts should be started earlier before boiler's shutdown so the function of the equipment like fans, pumps, valves, dampers and so on can be seen. For example during the extra sootblowing it is easy to check the condition of the sootblowing lances by standing next to the operating lance and listening to abnormal noises or making other abnormal observations.

In this case it can also be seen the proper function of the boiler by checking that all measures are ok and no abnormal observations are seen.

With visual inspections the main condition of the boiler and its parts can be seen. For some cases visual inspection is enough for executing inspection of some not so critical parts.

8.4.2 NDT-INSPECTION

Boiler wall tubes and superheater's tubes thicknesses are the main objects for the NDT-inspection.

Wall thickness is measured with ultrasonic meter. Before execution of this test operation tubes must be cleaned in the measuring area to ensure right measuring result.

Other method of the NDT-inspection used with the boiler parts is the magnetic particle test and penetrant test. With these tests cracking of the materials can be seen.

8.4.3 DT-INSPECTION

In some inexplicable material failure test part can be taken for further examination of the material. For example piece material failure can be seen in composition level and cause of the material problem can usually be revealed.

8.5 MEASURING DEVICES

Measuring devices must be calibrated before testing to ensure realistic information. There are two types of measuring instruments: permanently installed measuring device which is installed permanently for continuous process measuring and movable operator used devices.

8.5.1 FLOW METERS

- Magnetic flowmeter:

Magnetic flowmeter is accurate, instrument does not cause pressure losses and variation of measured material doesn't affect the result.

These two things are the only disadvantages of the instrument: magnetic flowmeter can measure only conductive liquid, it does not work with gases.

Magnetic flow meter measuring method is based on Faraday's induction law: *in conductor what moves in the magnetic field with right angle, induced voltage compared to conductor velocity.*

Permanently installed instruments measure the process constantly and give information to the operator and automation system. Movable types of measuring instruments are used mainly at shutdowns and for inspection purposes.

Principle of the magnetic flowmeter is presented in the picture 23.

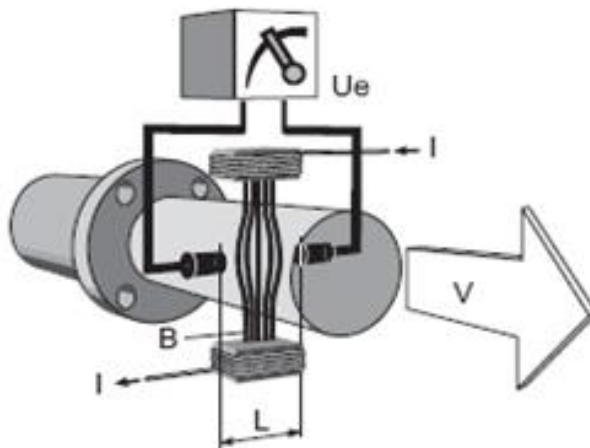

Picture 23. Magnetic flow meter

- Orifice plate

This method is based on pressure difference and it is suitable for measuring of pure liquids, steam and gas.

This flow measuring device is cheap and easy to install, but it is quite inaccurate and causes pressure loss of measured material flow.

Principle of the Orifice plate flowmeter is presented in the picture 24.

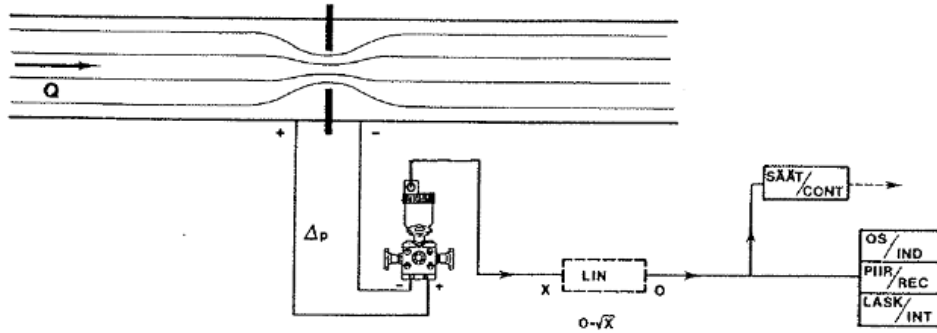

Picture 24. Orifice plate flow meter

- Vortex

Vortex type measuring instruments are used with liquids, steam and gases. It is accurate measuring device and it is suitable for example measuring of natural gas flow.

This measuring principle is based on vortex flow whose frequency is transmitted to the pulse generator.

In the picture 25. operation principle of the vortex flow meter can be seen.

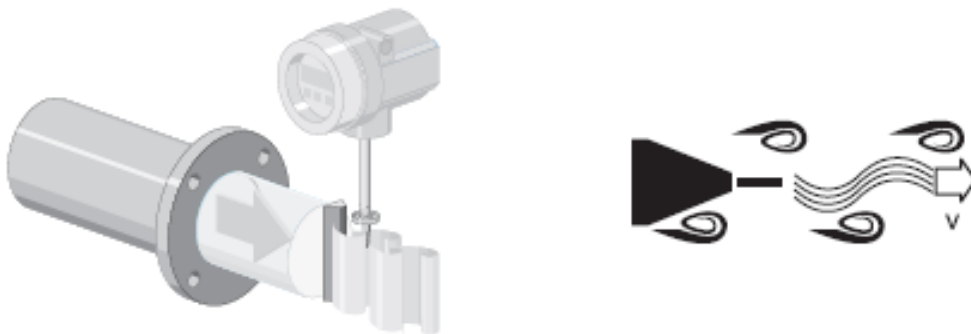

Picture 25. Vortex flow meter

- Coriolis

This type of measuring instrument can measure both density and flow of the liquid. Main principal of the Coriolis instrument is that two omega shaped measuring tubes are installed side by side and they are made to oscillate. In this way the tubes rotation angle is directly comparable to the mass flow through the instrument.

Coriolis flow meter is presented in picture 26.

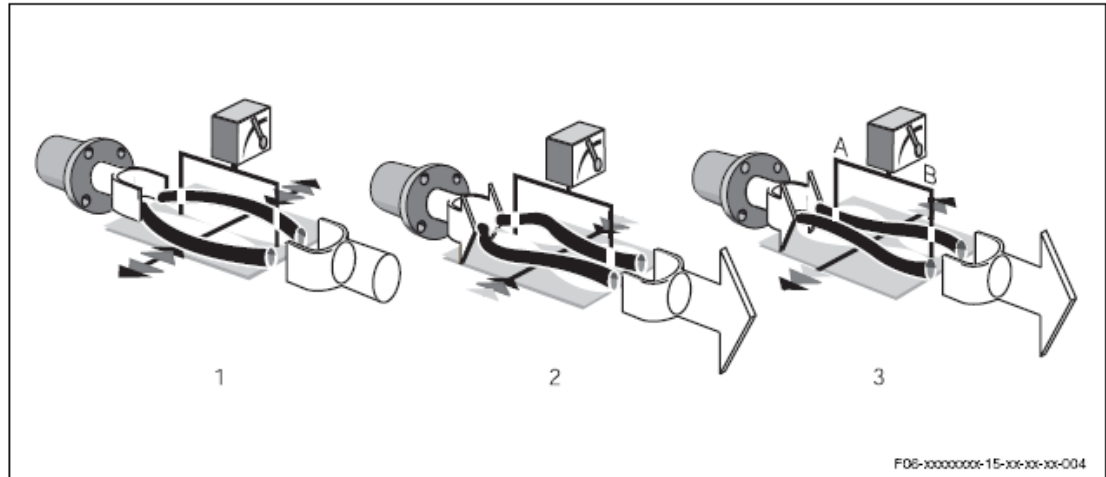

Picture 26. Coriolis flow meter

8.5.2 LEVEL METERS

- Flange transmitter

With flange transmitter level of the liquid material can be measured very easily

Flange transmitter's measuring principle is based on hydrostatic pressure.

Flange level meter is presented in picture 27.



Picture 27. Flange level meter

- Bubble tube

This measuring instrument is good for wells, canals and liquid tank level measuring.

Measuring instrument can be installed on the tank and it needs no measuring tapping. Measuring method is based on hydrostatic pressure.

This type of instrument is suitable also with sedimenting liquids.

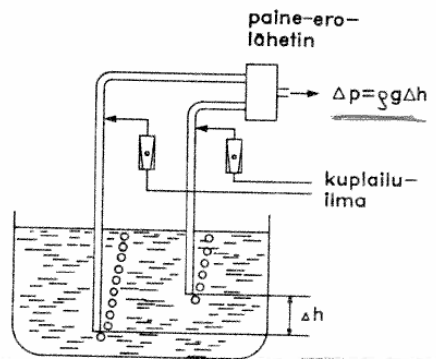

Picture 28. Bubble tube level meter

In the picture 28. it can be seen that two different length tubes are inserted from above to the tank.

Two tubes are connected to the pressure-difference measuring device which measures inserted air pressure difference and in that way level of the liquid material can be measured.

8.5.3 TEMPERATURE METERS

- Thermoelement and PT 100 Sensor

Thermoelement measuring range is up to 400 °C whereas PT 100 sensor's measuring range starts from 400 °C. These sensors have numerous applications but these sensors are not suitable for measuring of furnace temperatures because of furnace's high temperature.

Thermoelement is based on two thermowires which are connected to a closed circuit and direct voltage is generated (mV) when heated. This voltage is straight comparable with temperature.

In the picture 29. the main principle of the Thermo element is seen (T1= measuring point and T2 = point of reference).

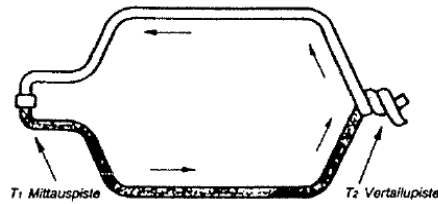

Picture 29. Thermo element temperature meter

The measuring principle of PT100 sensor is based on variation of resistance which changes with temperature, PT100 sensor measuring results are shown as a current change (mA). Outlook of the PT100 sensor is presented in picture 30.



Picture 30. PT100 Thermo meter

- Pyrometer

With pyrometer high temperatures range between 600-1300 °C (depends on the supplier) can be measured and in short time even 2500 °C of temperatures.

Pyrometer is the only temperature measuring device if flue gas temperature straight from the furnace needs to be measured.

In very hot places pyrometer needs water or air cooling.

The measuring principle of pyrometer is based on radiation power that heat from the measured object emits. Pyrometer look is represented in picture 31.



Picture 31. Pyrometer

8.5.4 DENSITY METER

- Radioactive density meter

Radioactive density measuring device does not need to be in touch with measured material and is therefore easy to install. The main principle is that sending and receiving part of the measuring instrument are on opposite sides of the tube and measured material flows through the sensor. When received radiation weakens density of the material is higher. The main measuring principle is presented in picture 32. Disadvantages of the radioactive measures are the used Cs 137- isotope which may not have permission to installation and use in every country.

In the picture 32. Can also be seen that the process pipe goes vertically and radioactive measuring instrument is attached around the tube.

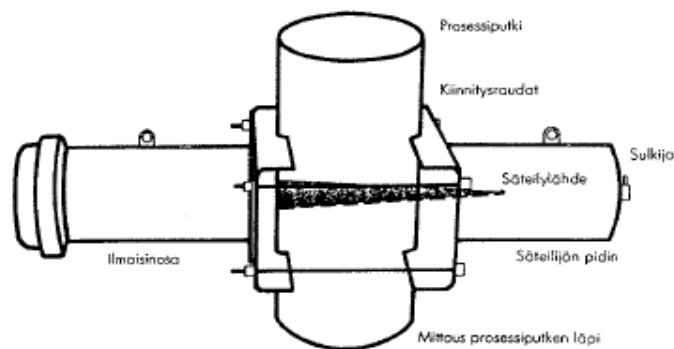

Picture 32. Radioactive density meter

8.5.5 PRESSURE-AND PRESSURE-DIFFERENCE METERS

Pressure and pressure difference measures are used with measuring of steam, water, flue gases, filter's condition and so on. Pressure difference is the most common measuring principle of the boiler section. Pressure and pressure difference measuring instrument functions with pressure transmitter which transforms pressure message to standard current message (mA).

8.5.6 WALL THICKNESS METERS

Wall thickness measuring devices are only used when some part is suspected of wearing like superheater tubes and furnace wall tubes. These measurements can be performed only by hand and it requires entering near the inspected target. Usually wall thicknesses are measured with ultrasonic measuring devices.

8.6 AUTOMATION

Automation is very important part of the boiler's operating system, it controls the combustion and heat/electricity production overall and helps operators keep boiler running.

Automation prevents boiler failures also when operator is not able to do it or something unexpected happens.

Automation should be inspected in all shutdowns. Automation system inspection is testing required by authority and needs authorized person to execute the test.

8.6.1 SRS

SRS is separate from the process automation system. SRS is security system which contains interlocks and other boiler safety related system like emergency stop buttons and safety limits of the equipment. SRS prevents with interlocks users from unsafe actions with boiler. SRS-system need to be tested in every shutdown.

8.6.2 DCS-SYSTEM

DCS-System controls all other actions of the boiler. DCS-Systems handle process measures, -control and -driving.

Main parts of the DCS-Systems:

- IO input/output
- Bus interface
- Process station
- Engineering station
- Control station / operation station

8.7 LEGISLATION OF INSPECTION

Inspection of the pressure parts and safety related system's is action which is required by authorities. Legislation of the pressure parts and safety systems is deeply depended on where the boiler is located and contents of the inspection legislation may vary.

When planning the boiler inspection and maintenance, the operator must always be familiar with the legislation of the country to ensure the right inspection requirements and safe working.

9. CONCLUSIONS

Because of inspection scene is really wide and inspection methods will be more and more sophisticated in the future, this thesis gives a good basic structure and guidelines for a deeper and deeper inspection methods, maintenance and observations. Inspection planning will be easier in the future when monitoring of the boiler condition and operation will be more automated. That will increase safety of the boiler operation which means fewer incidents.

REFERENCES

World energy consumption by fuel type 1990-2040. U.S. Energy Information Administrator. (Read 4.2.2014) Available: <http://www.eia.gov/forecasts/ieo/world.cfm>

Kraft and Paper Mill Services Division, Andritz Oy, 2014, SRS Periodical testing.

Tuomainen R. Andritz Oy, 22.11.2010, CHP Boiler Operation and maintenance manual.

Recovery Division, Andritz Oy, 2008, Power Boiler Training Spring 2008/SHU.

Korpirinne A. and Merriman N., Andritz Oy, 2012, XT- Cross technology training 7.-9.11.2012. Vierumäki Finland Bower Boiler.

Andritz Oy, 22.3.2011, Recovery Boiler – Inspections during annual shutdown.

Forsström S., Andritz Oy, 18.8.2008, Safety automation periodical test plan RBS-Z20.

Andritz Oy, 12.12.2013, IP Workington Biomass boiler – Shutdown inspections report draft.

Karvonen A., 16.9.2011, Lappeenranta University of technology, master's thesis, Huolto ja kunnossapitoliiketoiminnan tuotteistaminen.

Hulkkonen S. and Kauranen T., Technical Association of the Pulp and Paper Industry of Shout Africa, Andritz Oy, Technical paper high performance biomass boilers for green energy production. (Read 24.2.2014), Available: http://www.tappsa.co.za/html_index_links/html_issue_Nov_09/biomass_boilers.html

Nondestructive testing. Wikipedia (Read: 24.2.2014). Available: http://en.wikipedia.org/wiki/Nondestructive_testing

Laine H., 1996, Scandinavian Center for maintenance Management Finland ry., Käynnissäpidon johtaminen ja talous.

Barrer R.D. and Peters B.F., 1970, Gordon and Breach science publishes, Why metals fail.

David N. French, A., 1993, Wiley-Interscience Publication, Metallurgical Failures in Fossil Fired Boilers.

Finanssialan keskusliitto, 7/2007, Kattilalaitoksen turvallisuusohjeet, (Read 25.2.2014), Available:
http://www.fkl.fi/materiaalipankki/ohjeet/Dokumentit/Kattilalaitosten_turvallisuusohjeet.pdf

Franco D., 20.5.2013, Bachelor's Thesis UAS, Design a Bubbling Fluidized Bed (BFB) Boiler for Research Purposes.

UNEP, The Clean Energy Voyage 2013, Read 10.3.2014
<http://www.unep.org/climatechange/ClimateChangeConferences/COP19/Blog/tabid/131171/catid/50030/Publications.aspx>

WHO, 7 million premature deaths annually linked to air pollutions, (Read 25.3.2014)
Available: <http://www.who.int/mediacentre/news/releases/2014/air-pollution/en/>

Paris car ban imposed after pollution hits high, BBC News 18 March 2014, Read 25.4.2014, Available: <http://www.bbc.com/news/world-europe-26599010>

Poltto ja palaminen, International Flame Research Foundation- Suomen kansallinen osasto, Teknilliset akatemit

APPENDICES

Appendix 1: Annual shutdown inspection planning for BFB Boiler (Confidential)