

LAB University of Applied Sciences
Institute of Design
Degree Programme in Design
Interior Architecture and Furniture Design
Bachelor Thesis / 69 pages
Spring 2022 / Carolina Andrea Mac-Iver Gonzalez



ERGONOMIC FURNITURE FOR SEX-LIFE

Indigo Bench

ABSTRACT

“Different solution for different needs”

The focus in the thesis was design a furniture solutions to provide comfort and ergonomic for one natural, health and basic act, which we do with a person we want or love in our home. We talk about sex and sexual positions.

Sex is much more than taboo and underground thinks. It is the principal expression of emotions and communication. Unfortunately, now the market does not have a variety list of nice and functional furniture where we can have comfort and ergonomic to practice sex at home. This is the reason, why I choose this topic.

The innovation of this thesis project is how I designed furniture for the sexual position which is possible include in our home. The bench was build it with noble and warm materials such birch plywood and leather. Just to have this product in a harmony concept with the other standard housing furniture we have at home.

So, this thesis is the result the whole process of a furniture design through research, interviews, analysis, drawings, 3D modelling and building process of more than one prototype tested for standard people.

This project is for everybody who enjoy the act of sex; young, medium age, elder, overweight, a physiognomy limited or for the people who do not have a comfort place in their own home. The basic idea is making the sexual relation ship easier for everybody and at the same time to have beautiful furniture at home.

Key Words

Ergonomics, Furniture Design, Ergonomi, Sex, Sexual Ergonomy, Furnitures, Ergonomics
Design

TABLE OF CONTENTS

1. INTRODUCTION

1.1. Thesis.....	5
1.2. Motivation.....	5
1.3. Objective.....	6

2. DESIGN PROCESS

2.1. Idea.....	8
2.2. Interviews	
2.2.a General Questions.....	10
2.2.b Physognomy Questions.....	11
2.2.c Articles on the Network.....	12
2.2.d Technical Questions.....	13
2.3. Benchmark	
2.3.a History.....	14
2.3.b Benchmarking.....	14
2.4 Ergonomics Studies	
2.4.a Analysis of ergonomics in Standard Housing Furniture.....	16
2.4.b Human Scale.....	19
2.4.c Body Measurements.....	19
2.4.d Building a First Prototype for Ergonomic Research.....	20
2.4.e Analysis of the Testing Process.....	22

2.5 Sketches

2.5.a Abstract Drawing.....	29
2.5.b First Technical Drawing.....	30
2.5.c Final Technical Drawing.....	31
2.5.d 3D Modelling Evolution.....	35
2.5.e 3D Final Modelling.....	37
2.6 Prototype Material.....	40
2.7 Prototype Building Process.....	41
2.7.a Cutting Pieces of Plywood in CNC Machine.....	41
2.7.b Handmade Screws for the bench.....	42
2.7.c Assembly Test.....	43
2.7.d The Sanding Work.....	46
2.7.e Vanish Process.....	47
2.7.f Logistic.....	49
2.8 Mattress.....	50
2.9 Put All the Parts Together.....	52

3 FINAL PRODUCT.....55

3.1 Conclusion.....	60
3.2 List of Reference.....	61

4. APPENDICES.....63

THANKS.....	69
-------------	----

1 INTRODUCTION

1.1 Thesis

Sex-related discussions have been a taboo in our society since ancient times. Having sexual relations with our beloved ones is a natural way to express love, provide pleasure, and enable the reproduction of human beings along the time. Although the study of the ergonomic aspects for sex may not look appropriate as the topics of a Bsc study, this is actually the main scope of the work that is reported here. Apart from the benefits that having good sexual relations provide to the health, communication and pleasure in a relationship, I believe that ergonomics and design should be also be taken into account. My thesis research is about how I can help, through design way, the everyday sex life at home. For this, I used the ergonomic method to understand the physiognomy of the human body in all processes of my project.

1.2 Motivation

The motivation I have, is find the correct ergonomic method to help the everyday sex life. Sex life is a normal activity for humans and is a challenge for me to develop a project in this term.

I want to make research which improve and help the ergonomic of sex life for the users. The motivation is design furniture which helps and makes movements easier and support the weight of the people. I want to design good element for home or other spaces. I hope to have a nice result which is not ordinary. Some elegant and functional furniture element to have at home.

1.3 Objective

The objective of my project is designing a new concept of furniture to be part in a Modern Architectural and Interior design life. Furniture which opens more the classical model concept we have in our traditional functional furniture now. This new concept is necessary at home because integrating the sexual life, us like one more activities at home for example to eat or sleep . My design is hybrid functional furniture with two different functionalities: a bench with normal use at home, and sexual furniture functional for sexual positions at home. This is a new window for Interior Design of how we understand the interior life at home. I have in this process, a real body experience, with people in standard physognomy to understand what kind of ergonomic human body needs.

What is needed?

Furniture improves ergonomic of sex life.

For whom?

For couples with sexual live active.

Why?

Because now in the market, there are not much nice and efficient products for this demand.

2 DESIGN PROCESS

2.1 Idea

The Idea born during 2017 when I talked with my friends about sex life and how difficult is sometimes had a good quality sex life and positions, because there is not a good place at home where we can do it. One of my friends was laughing for while she approved.

From that year, I started to think what can be possible to do and what kind of product is missing in our home for sex-life purpose.

The first person with whom I talked about this possible project, was my young brother Jorge Mac-Iver, who was at that moment student in the Kinesiology and physiotherapist school of the University of Valparaiso in Chile. He said, the idea was very good, but, for think better how the ergonomy body and design works together, must be necessary test the positions with real person in a really human scale maquete of furniture in 1:1 scale.

I remember when I talked first time in school about this idea with my tutors teacher Timo Sulkamo and Harri Kalliomäki at Lab school, they were positive about the project idea.

So, I started working in this idea with functional design, beautiful aesthetic and easy manufacture a piece of furniture which provides sexual comfort for couples.

Potential Users

a. For all couples who have sexually active life: Sex is not related to age or different levels of fitness of the people. Everyone has the right to have sex and enjoy it in comfort.

b. Suitable for couples with overweight: If we have overweight, it is more complicate movements or keep the heavy body for long time in many of the sexual positions.

Sometimes the extra weights produce fatigue and destabilises the balance of the people involved. In this point I speech from my personal experience. A bed or chair does not help.

c. Couples with small children: Being a parent is a great experience of life, but it is also exhausting. Family life, like a work routine, produces mental and physical fatigue. Many times, the act of sex in a parental family life ends up being a second priority. The spaces in a house or apartment, are usually not intimate or private for the couple. The family is everywhere, and many times they spend time in the parent's bedroom. When this happens, the parents try to find other places at home or furniture, like in a living room, on the sofa or on the carpet and also bathroom. The armchair can be an option for parents when kids are not awake looking for them.

d. Suitable for elderly people: The sex is pleasure for all ages people. Unfortunately, for while the years pass by we get older, our body loses flexibility, strength, and resistance. The wish of pleasure is always present with us. That is why I want to make the act easier. So, I think if we can have our legs on the floor, they may be possible support our bodies and get more stability and balance when we are moving. This way, the back and pelvis of the body will not be forced, preventing possible health-related problems. The idea is, not getting any muscles pain make basic movement.

e. Suitable for most muscle, articulation and bone related-problems in all ages: This kind of health-related problems may appear at all ages, not only with senior people. A muscle pain or another ligament problem or body pain will be influence in how we do sex. Sex is an act of movement were every part of our body and mind work on coordination with our partner. The areas of the pelvis, hips and buttocks are in continue contraction and movement. It would be nice to have a proper support for those parts when we have the act of sex. Just to prevent an eventual pain.

It is necessary a product which help to keep the constant movement in sequence of time and avoid a possible pain because of that.

2.2 INTERVIEW

2.2.a General Questions:

To understand more about what is needed, I asked from different adult people. So, I got my pen and paper and then I went to ask the different people of my social environment two questions, the first question was: "WHAT IS SEX FOR YOU". I asked from different genders, ages between 25-60 just to understand what means sex for the people, in purpose to get another vision what really people think about it. When I asked them, some people were happy to answer, and many other people became nervous. Of course, they did not wait for a question like that, but then when I explain to them about my project and idea, the words just came out.

To my surprise, the answers were super positive and this was a nice inspiration for me. Words like these: ART, MOVEMENT, FUN, FREEDOM, DIVERSITY, REPRODUCTION, WITHOUT TABOO, EROTICISM, LOVE, HEALTH, COMMUNICATION, IMAGINATION, CULTURE, FEELING, COMPANY, SHARE, NATURAL, ORGASM, PASSION, LANGUAGE, WISH, PLEASURE, LAUGH, DIVINE, PRAY, MARVELLOUS, EXPRESSION, COORDINATION. ETC.

I was glad to hear that words of that kind. There are only words with nice and positive means. That is the first prove that Sex means something positive for couples. Why Sex then is a taboo in the year 2021, if the perception of the people is more positive and nicer than I thought?

When we talk about the Act of Sex, it means communication between couple, it is how we perpetuate our species, it is how we express our love, feeling and wishes for each other or for our self. Sex is the most fun and beauty act what we can do with our couple. There are Scientifics research which prove when we have sex, we generate endorphins hormones and those hormones influence in our happiness feeling.

Then, the next question I asked for the people was: "WHERE DO YOU HAVE SEX", I got a list of different places like this: on the sofa, or in the bed or where can be possible at home or the place does not matter when the passion calls.

All these answers are valid, there is a variety of furniture, inside places and outdoor areas. Those interior places and furniture of the list have in common one issue. In the case of furniture and car, all were designed for a different purpose, but NOT FOR SUPPORT THE ACT OF SEX.

2.2.b Physiognomy Questions:

To understand more why this idea is needed, I went to talk with Ann-Mari Nordman, Physiotherapist, and exercise instructor from Lahti, who is special expert in pelvic floor and sexual counselling musculoskeletal, and sport medicine, with long experience instructing groups like Pilates, Yoga, body management and maintenance, muscle fitness. She has published an English language book "Ultrasound Image and low back pain" 2011.

She said the problem in ergonomics of sex exists. She has listened throughout her professional career people with physiognomy problems like in the back, knees or ankles and how this affects them to have a normal sexual life. The mattress of beds does not help when the act of sex happens. Because it is necessary for the body joints to maintain the movements. She mentioned, for example, the pelvis of female and pelvis of the male need to be in an easy position for the penetration, and that is complicated. She said that it would be good if there is something to keep the pelvis in the same level (like a pillow). This would be good if we support or keep the balance of our bodies from the floor.

By my personal mention, I want to say, it is important to keep physiotherapy treatment when our bodies need it. Our body is the machine that moves our mind, conscience, spirit, and soul, we need to take care of it. It is good to follow the recommendation of experts to keep our health in everyday life, work, and sex.

2.2.c Articles on the Network

The topic I am following is not new. There are specialist sexologists who write information and research on the network by articles or blogs. Professionals who offer their services to improve and help the sexual life of people. It is possible read this full article on the web address. (Figure 1)

<https://loverollers.com/love-sex-relationship/why-do-sexologists-recommend-sex-furniture-for-a-better-love-life/>

Different information also in :

<https://drshannonchavez.com>

LoveRollers®
LoveRollers® | Tantra Chairs India | Made in India



Why do sexologists recommend sex furniture for a better love-life?

By **LoveRollers®**
LoveRollers® | Tantra Chairs India | Made in India

So, what is it that your partner loves in bed? Is he bold and daring, and does a session between the sheets with him leave you satisfied and exhausted? Well, that says a lot about your man. The reality is that every man has a favourite position, depending on his age, physique and nature. So what does your partner's favourite position say about him? Dr Shannon Chavez Qureshi, Clinical Psychologist and Certified Sex Therapist from Los Angeles,

California, USA (www.drshannonchavez.com) says, "A man usually chooses a position that allows him to feel dominant and exercise his maximum pleasure. Other times, a position preference may be based on mood or energy level. At times, for a more sensual connection with a partner, your man may want to be face-to-face and body-to-body where he can gaze into his partner's eyes and inhale his partner's aroma while engaging in sexual activity."

Figure 1. Excerpt from the article "loverollers" about how furniture can improve the quality of sex-life.

2.2.d Technical Questions:

To understand how I can do it or what is needed. I called to A. M. who is the Managing Director of Tempur Sale Finland Oy. He knows everything about the foam beds and pillows to provide the good resting. So, in our conversation about how the foams are, he says the Tempur foam is a pressure-relieving surface, engineered with viscoelastic open the cell that absorbs and evenly distributes the weight of your body for maximizing comfort.

He said Tempur has 3 best Properties:

-Viscoelastic Material

-High-energy absorption

-Soft pressure-relieving properties.

This discussion gave me more knowledge, how good the foam is for rest and static positions. After this discussion, I understood how complicate is to have sex on the bed. The designers and inventor haven developed material to absorb the energy and keep the bodies in static. So, this proves the beds work perfectly for rest, but not for movement and sex.

What I want design is comfort for the movement and coordination of bodies. For that purpose, I can not use a Tempur foam in my project. I do not want to put the couples at sleep. I want to keep them in movement.

2.3 Benchmark

2.3. a History

The idea of ergonomics for sex is not something new. The idea came from years ago. It is an example, the “Love Chair”, created by a French manufacturer in the early 20th century, designed specifically for the British King Eduard VII. One of the luxurious brothels “Les Chabanais” in Paris provide this ergonomic furniture to the King who was an overweight, and the same time it was complicated for him to correctly enjoy the act of sex.

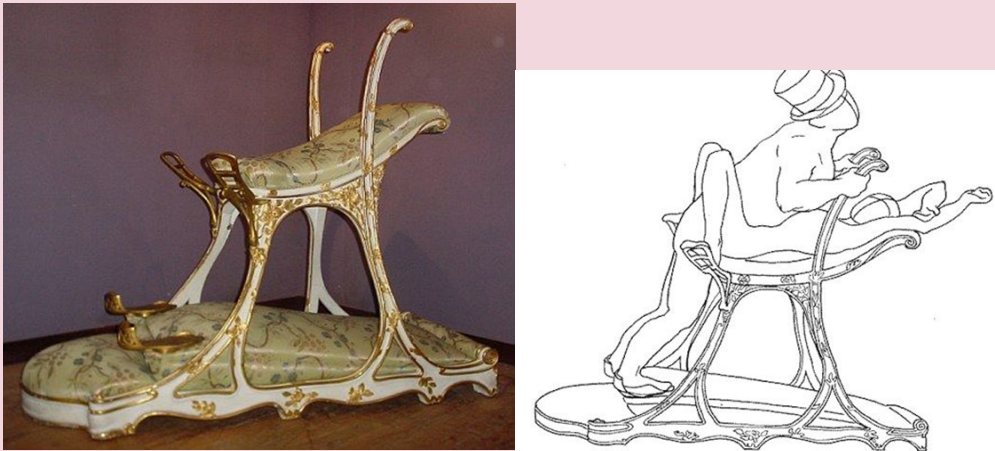

Figure 2, 3. Furniture designed for King Edward VII, the replica of this furniture is in The Sex Museum of Praga. Photo from web article.

The design provides support and positions of the man's feet and for while the lady rests in the ergonomic surface. The measurements and the length of the chair legs etc were for the King. (Figure 2 - 3)

2.3.b Benchmarking

2.3.b1 “Adela chair” Designed by Balastudio from Mexico. This chair provides to the woman and to the man a comfortable position for the act. The man sits with inclination on the back, and he opens the body area of pelvis and extends the legs, and the woman can use the elements like horns for hold on and the elements in the legs of the chair for support the foot and push and hold the movement.

This piece is handmade work and the materials are fiberglass, polyurethane, and leather. (Figure 4-5)

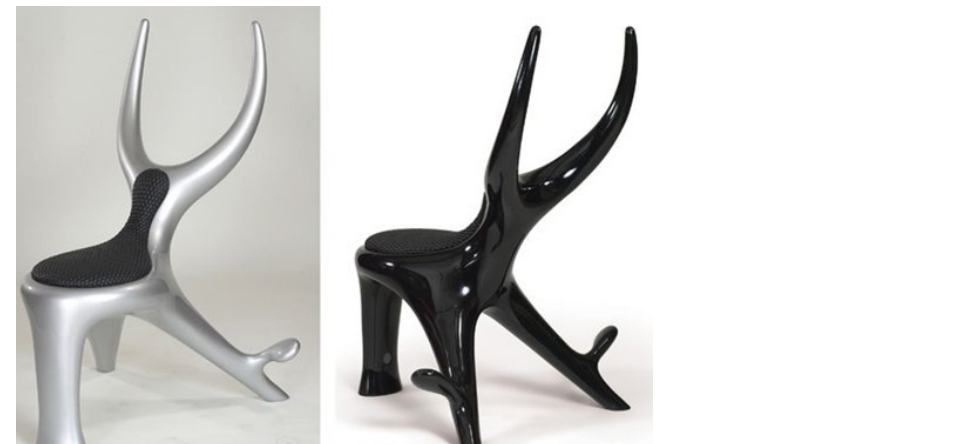

Figure 4-5. Adela Chair designed by BalaStudio. This product is available in different colours. Photo taken from article on the web “Furniture for sex”.



2.3.b2 “The tantra Chair” is a hand crafted in the United States. It is patented design opens the door for partners to be creative. Every angle and dimension are well calculated to provide comfortable for couples of all shapes and sizes, and relieves knees, back and shoulders from any pressure.

The surface is soft synthetic leather. Also, it is stain-resistant, moisture-resistant, and antimicrobial, making cleaning and overall maintenance blissful. (Figure 6)



Figure 6. “Tantra Chair”. The patented of this organic shape design is open, it is possible find the style of the model in different colours and materials. Photo taken from article of web “Furnitures for sex”

2.3.b3 “The Sex Wedge Pillows”

The sex pillows are two pillows that fit together to adjust all body types. Which “offers adjust to all variety of angles and positions”. Technically two sex pillows, this dynamic duo, will undoubtedly help you find angles that work perfectly for couples. Since this combo is a bit of larger set, this cushy sex must have is great for bigger-bodied lovers. The wedge and ramp positioning pillows can be used separately or together. (Figure 7)

Figure 7. “ The Sex Wedge Pillows”, photo taken from article of the web “Furniture for sex”.



2.2.b4 “Liberator Wedge Intimate Sex Positioning Pillow”

This is one of the most popular sex position pillows. This tried-and-true option offers a subtle incline and firmness that is ideal for providing support for the missionary position. Material is high-density foam with a microfibre cover. (Figure 8)



Figure 8. “Sex positioning Pillow” photo taken from an article of the web “Furniture for sex”.

2.4 Ergonomics Studies

2.4.a. Analysis of Ergonomics in Standard Housing Furniture.

Analysis 1: The first furniture on the list is the bed. The bed was designed for sleep. I mean, the purpose of the bed is for resting and provides comfort for the users when they sleep. Support for static position. That is an act without movement.

The mattress of the bed is designed with foam to keep the human body in resting position, not in moving position. Also, the width of the bed is something between 1400 -2000 mm, that makes difficult put our legs on the floor. It is maybe easy use the bed when we are young, and we have an energy and strong physiognomy. However, time past, we get older every day and many of us have an extra weight. Our bodies are different. With different measurements, structure, and energize.

About the positions, we do in our bed, for example, one is when the woman is up. The man is in the rest position in a back side and the woman is seating in his pelvis. The woman needs to push up the body in every movement by using her legs and knees on the foam mattress. There is difficulty in order to have a good balance for female. Because, the support comes from a non-stiff surface. The female needs to use a lot of energy with her legs. (Figure 9)

Another example position is, when the female is resting looking up, and the male is up, this position is named “missionary”. There is necessity to put something under the pelvis of the woman, for example the pillow, just to move up her pelvis into the same height of the male and made the act more comfortable for both.(Figure 9)

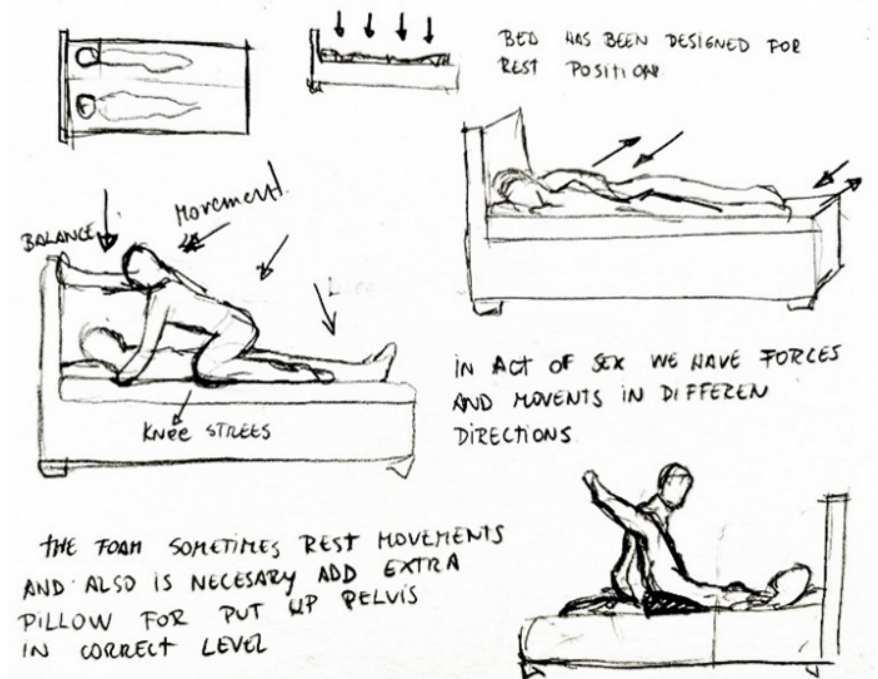

Figure 9. Sketch made by me, to understand how generla position work on the bed.

I would like to have the possibility to measure the among of energy the couples loose during to get the proper balance to do not fall or scratch the knees. The energy they lost in those trying to get the ergonomic position should be used for enjoying and to have longer pleasures moments.

Analysis 2: Sex on the chair is also complicated. The chair was originally designed to provide ergonomic for sitting and resting in a static position. There is an angle for back support, and for seat support are ready measurements. When a couple wants to have sex on the chair, the female needs to sit on the legs of the man. The man does not have proper a angle for his back and the female sometimes does not have long enough legs, and she can not get support from the floor. There is no stable position available. (Figure 10).

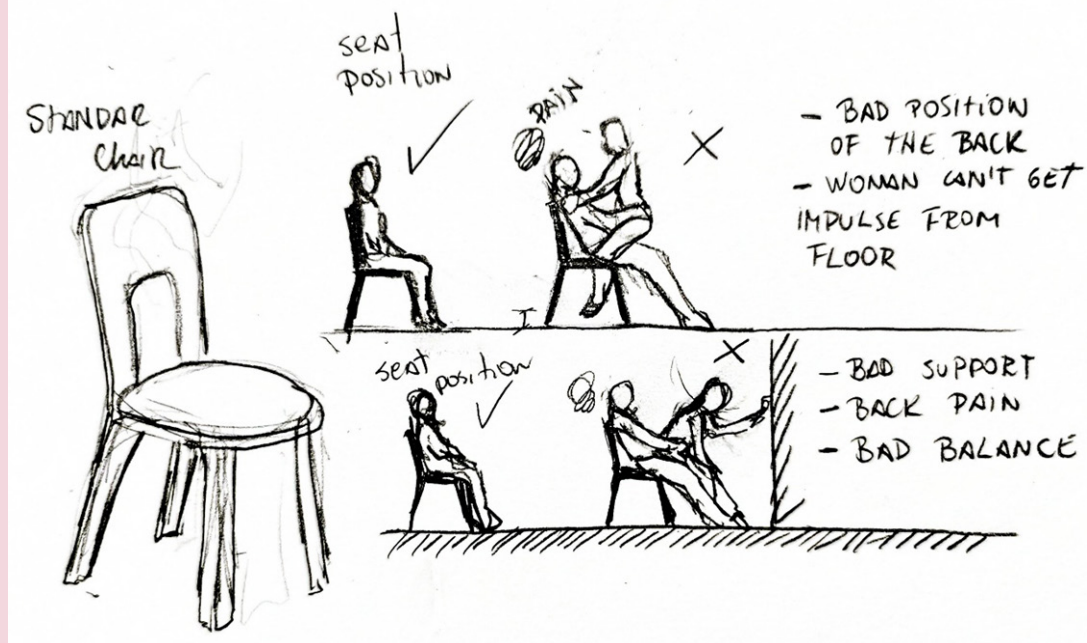

Figure 10. Sketch made by me, to understand ergonomic and some positions in a standard chair.

Analysis 3: Sex on the sofa. This living room furniture has been designed for resting. However, it is more versatile when a couple wants sex. Maybe is because there are pillows which can be move or change the position to get an "Improve ergonomic".(Figure 11).

One persons that I was interviewed explains the preference of using the sofa, because there are pillows to get better comfort. Another person also preferred the sofa instead of the bed to have sex, but the problem is the sofas are not resistant. In some cases, the sofa broke down, because the intensity or weights of the act were strong. This is because the sofa is designed for a resting position. If two persons are in continue movement, the sofa can be broken.

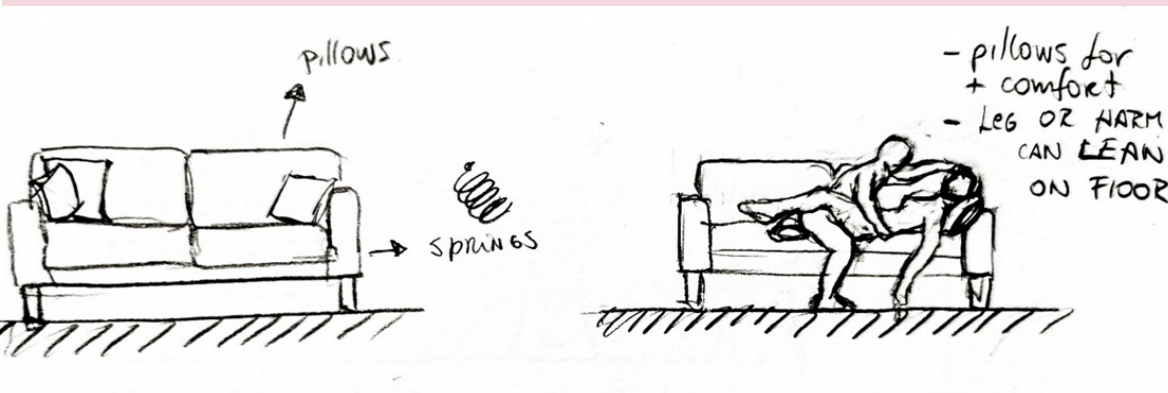

Figure 11. Sketch made by me about the analysis 3.

Analysis 4. Sex on the floor or on the carpet. This place is when nothing else is available. It can cause a scratching of the knees, back pain and many other pain or muscle problem because it is difficult to have sex on hard surfaces. (Figure 12).

Then, in the list are also interior places or outdoor areas. In those places, the needs, the imagination and the flexibility is more important than the ergonomic.



Figure 12. Sketch made by me, according Analysis 4.

Another answer to the question was: "The place does not matter when the passion calls". This sentence is interesting, because the wish for sex or the necessity of pleasure does not need a plan. This one just came and the comfort or ergonomic goes to second plane.

Therefore, do we need furniture where the people can have sex with more ergonomic or comfort? Something easy to have at home.

Well, according to my analyse, I can say YES.

Of course, a group of interviewed people said it could have necessary to have a furniture which improve or help to have a more pleasure in life.

The place does not matter.

The sentence "The place does not matter", came majority from people age between 20-35 years old. Many of them have single home life or who are in couples without kids. They have the freedom to do and go wherever they want.

Yes, it would be nice to have some furniture to make the movements of the sex easier.

This answer came from the group ages 30-60. They are married with or without kids every second week because of the divorce. Many are working or studying. The majority has overweight. Elder people do not be the strong or flexibility, as they would like to have.

2.4.b. Human Scale:

Designers create spaces and object such as steps, doors and chairs that are closely aligned with the human measure.

If I want to design a chair for example, the information about the human scale is in books and media to tell what the measure needs to be. For years, professionals and architects has been drawing and sharing information to develop the different furniture what human needs. How high the table must be, or what is the best ergonomic measurement for an armchair. Still when I went to search information for the measurements of furniture for sex, I didn not find so many data.

Now in the market exist some different objects and furniture for sexual life. Maybe functional, but not beautiful. I check the measurements of the tantra sofa for example, and should work well, but look an ugly and massive element. So, I got some ideas, for example, how much the height of seat part must be, or how width seat part needs to be in purpose to resist persons movement and to create comfort for them.

Figure 13. The human body has different shapes, weights, and lengths. My challenge was designing a standard prototype which work for many bodies.

The drawing is by the Austrian artist and sexuality educator Stefanie Grubl.

2.4.c. Body Measurements.

At the beginning of the project, it was a challenge to think how I can design something, which could be useful for different bodies with different shapes and different weights.(Figure 13). Just to keep in mind, the important thing is to design an element, which can support different human body shapes.

The idea to design a type of armchair or chair was not working, because those are reduced the movements.

Then, to my mind came the idea of the bench or platform with legs where the bodies can move or stay in comfort. It also needs to be strong enough.

To further develop this idea, I decided to build a basic prototype, where I put real people to try it. That was the best, because I see in real life, what is needed height and how the shape will be.

I took the width measure from the tantra sofa: 400 mm

And the rest comes with the test and ergonomics research.

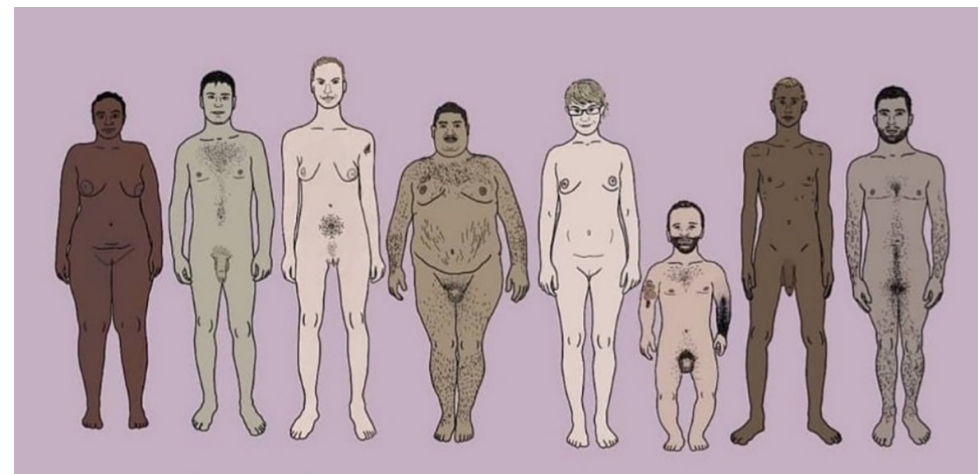

2.4.d Building a First Prototype for Ergonomic Research

The first prototype was made by plywood and polyester material to create shapes for ergonomics and comfort research.

The idea was to build a simple shape, like a bench. With the different dimension of legs.



Figure 14. Photo taken by Carolina Mac-Iver in Lab Wooden workshop.

The material of the bench is play wood and there are 3 different long sizes of legs (20 mm, 25 mm, 30 mm) which were easy to change any moment when was need it. Everything to search the correct high measurement. (Figure 14)



Figure 15. Photo taken by Carolina Mac-Iver in Lab Wooden workshop.

Do the ergonomic research, was necessary cut planks of polyester. That was for simulating the mattress necessary to improve a correct position of the people and the shape necessary for this furniture. (Figure 15).

The idea is try different possibilities of comfort in the Bench. There are many different height and shapes to try.

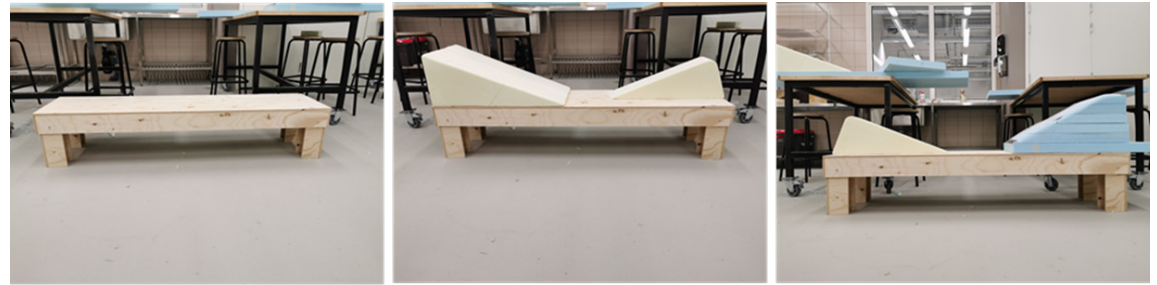

The model with different possibilities to try the comfort in the bench. The polyester was cut and sand to make the shapes and soft corners. Also, in these 9 photos.



The bench has 300 mm long legs. The height of the plywood bench is 310 mm height (legs + plywood platform). (Figure 16).

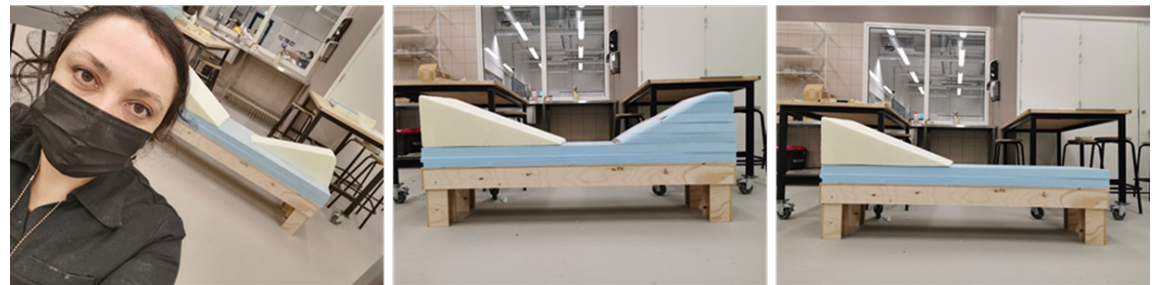

Figure 16. Pictures I took at Lab wooden workshop, for while I build the first prototype.

2.4.e. Analysis of the Testing Process.

Testing Process: “Ergonomic Research”

One of the important things to understand how the ergonomic apply in sex, is visualized a couple. When two people with different structure sit in a bench, they are in an static position. So, the bench resists the forces in one way only.

When this couple start to get the positions for sex, then is important to check if the structure of the bench can resist the impact and the weight of the movements. (Figure 17).



Figure 17. Sketches made by me during the testing process with a married couple.



Figure 18.

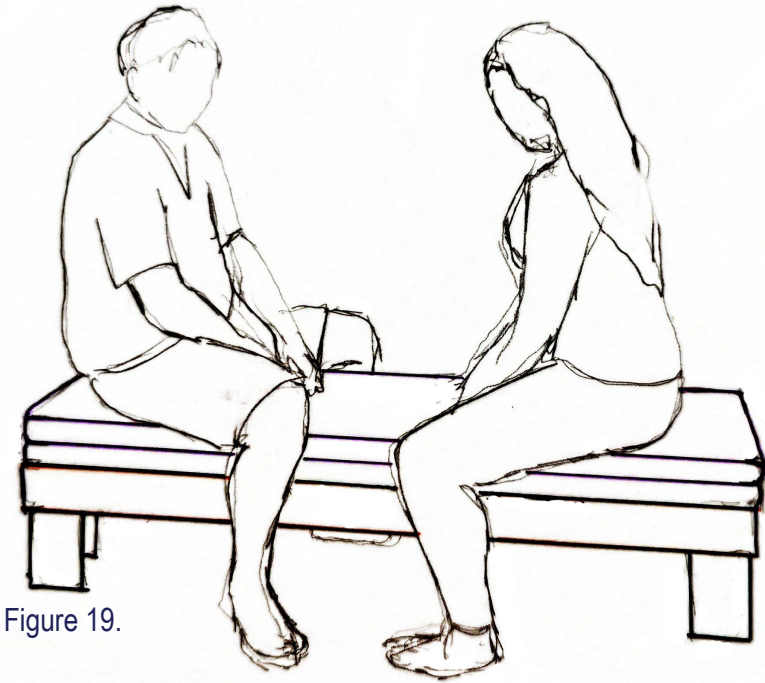

Figure 19.



Figure 20.

I took pictures of the couple on the bench in different seat positions. In these 3 scenes, the bench length of the legs is 300 mm, plus 10 mm plywood surface and plus 100 mm. The total high of the bench is 410 mm, almost standard height for normal seating bench. It is possible to get a comfort seat ergonomic. But...what will happen for sex use? (Figure 18-20).

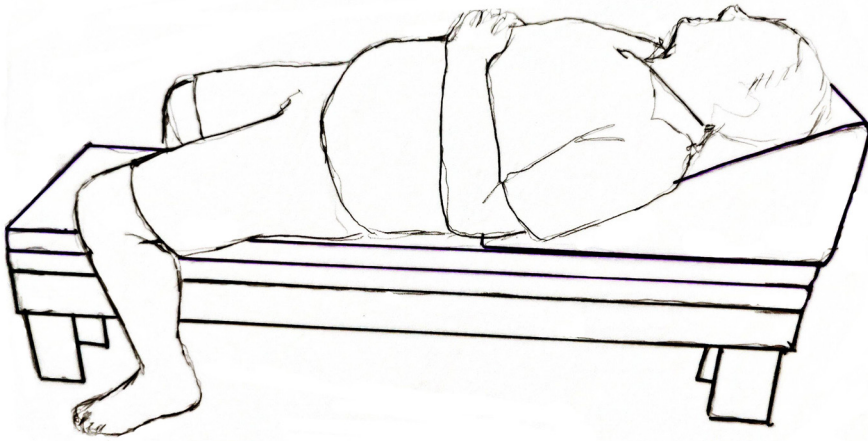

Figure 21.

In these sketches of couple, it is possible to observe at first one (Figure 21), the man has uncomfortable position for the back and the neck. He said that there was not proper support for neck.

In second sketch (Figure 22), the bench high 410 mm did not work, because it was too high for the sexual position. The female was uncomfortable when she set in the man's pelvis. The female did not get good support from floor (see the positions of her feet), she does not have balance, and she also feels discomfort in her knees.

In last sketch (Figure 23), I took off another 50 mm polyester. Just to putting more down his low back and pelvis, and at the same time I added an angular pillow to find correct position for shoulders, neck and head.

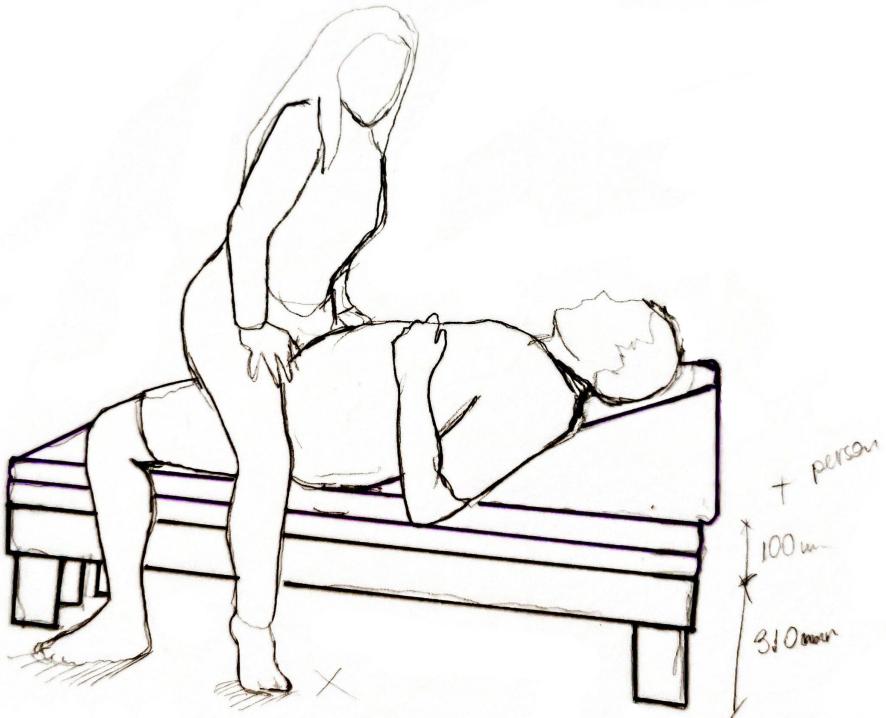

Figure 22.

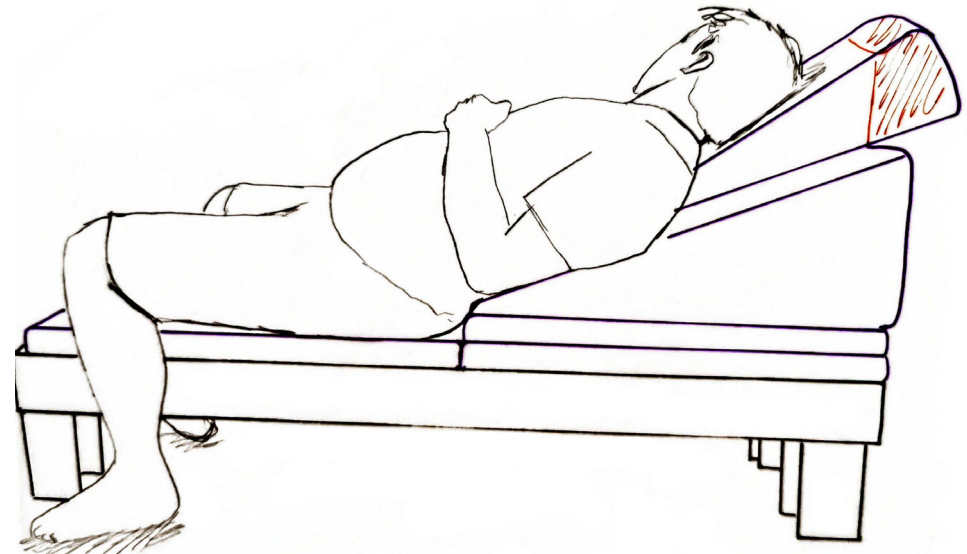

Figure 23.

Figure 24.



Figure 26.

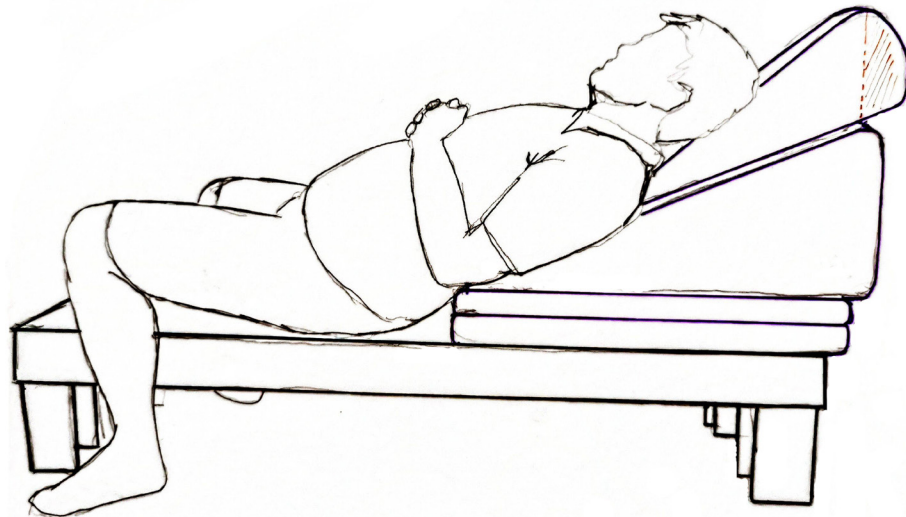
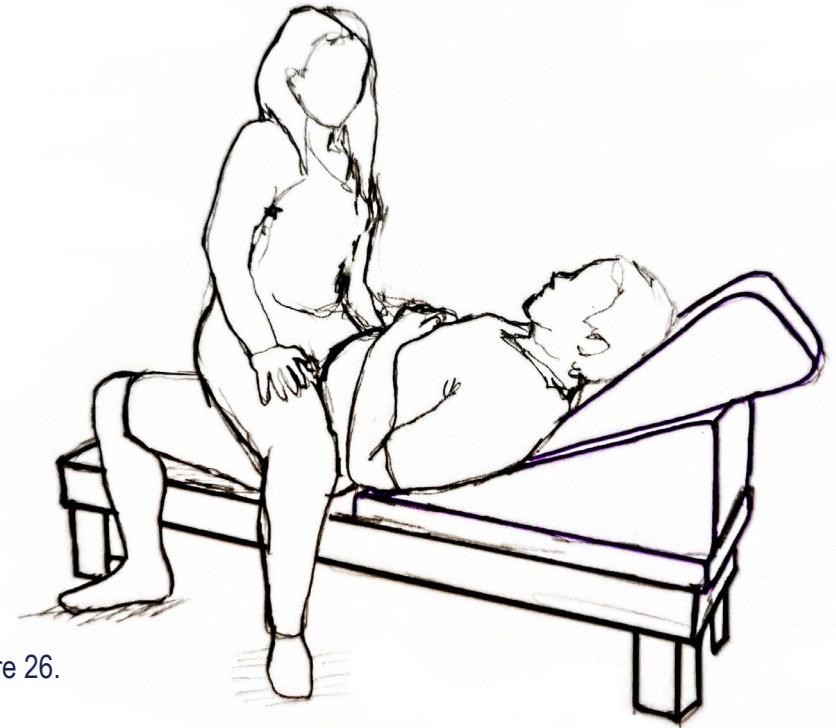

Figure 25.

In the first sketch (Figure 24) the position of the female is more comfortable, but not perfect. She can put part of her feet on the floor and the male has better back and neck support and ergonomics.

In second sketch (Figure 25), the bench height is 310 mm. The idea is to put the pelvis of the man nearer the floor.

In last sketch (Figure 26), the female can sit on the male pelvis more comfortable, the legs of both people are supported from the floor, and they can use the floor as a support for the movements.



Figure 27.

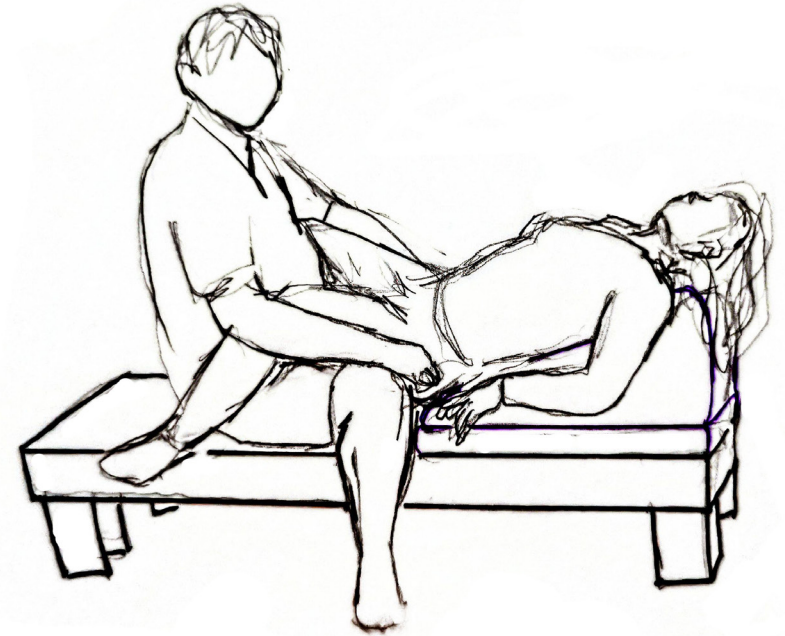

Figure 28.

In these sketches, I show three different positions which are also comfortable for sex. This is because the bench is narrow (400 mm) and is not very high (310 mm). So, the couple can play and change the positions always supporting the feet from the floor. (Figure 27-29).

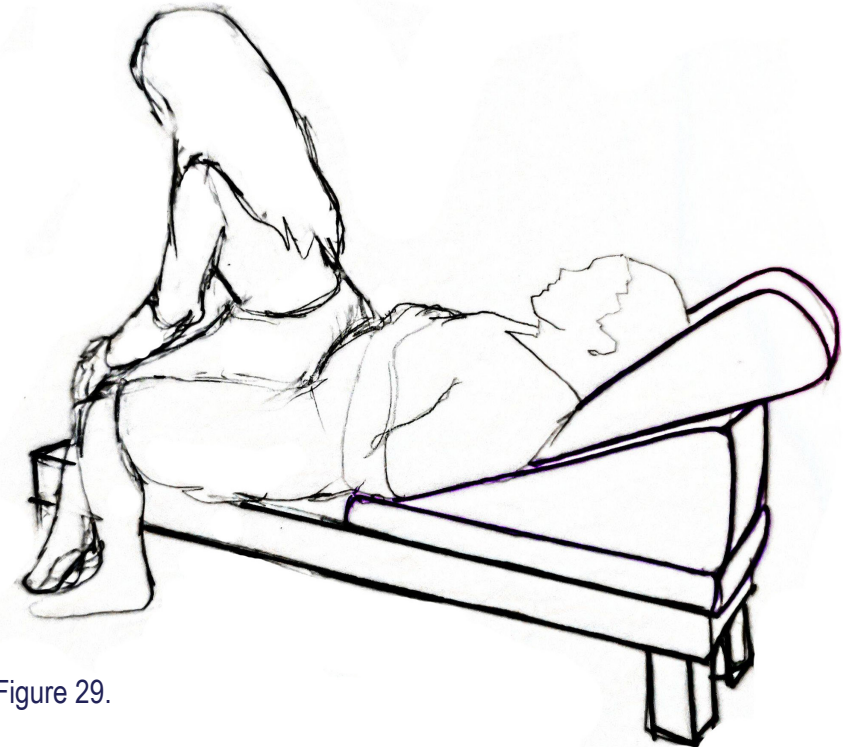

Figure 29.

The bench also has correct dimension for the position of the head and neck when someone wants rest.
For that ergonomic research, I tried many chances to see the measurements of a possible pillow. One example of this It can be seen in Figure 30.



Figure 30. Section of the bench, photo taken by Carolina Mac-Iver

The bench has the accessory pillow which could be used for the bed or the sofa when the couple would like to be on the bed.

The pillow for neck and head also has a second purpose. This one is for the movement up the pelvis of female when they are on the bed. (Figure 31).

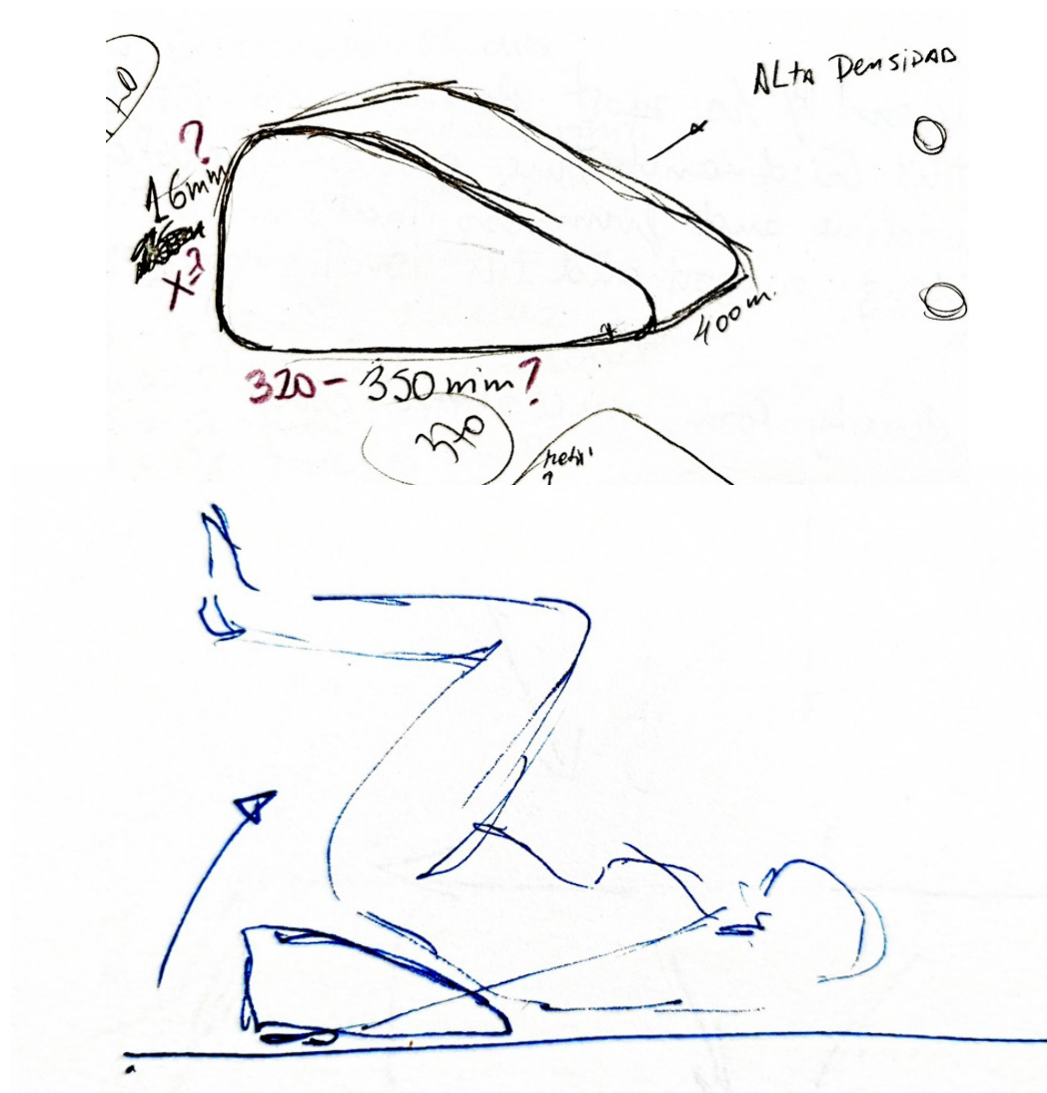

Figure 31. Handmade sketch I made during the design process.

2.5 Sketches

2.5.a Abstracts Drawings

The design of the final shape of the bench is the result of the ergonomic research. The shape has been modified many times. It was important to create a light and balanced shape. The legs structure need to be strong to resist impact weight in different places.(Figure 32-35)

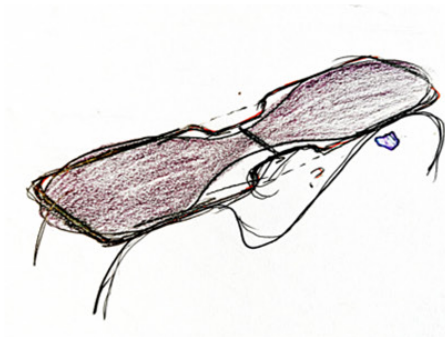

Figure 32. Abstract Sketch looking how the shape of the bench must be to give good positions for knees and legs. By Carolina Mac-Iver

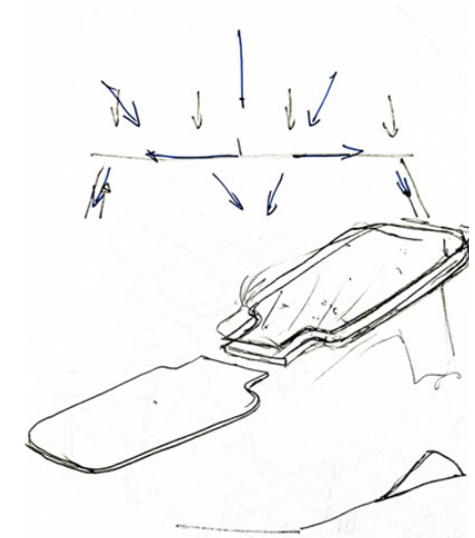

Figure 33. Abstract Sketch to analyse the dynamic weights and the forces to which the bench will be subjected. It is not static weight, it is moving weight. By Carolina Mac-Iver

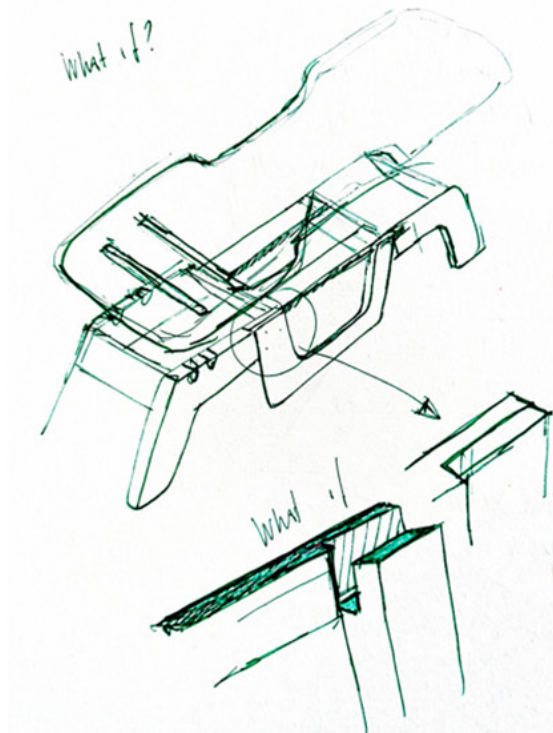

Figure 34. Abstract Sketch to analyse the strong legs this bench need. By Carolina Mac-Iver

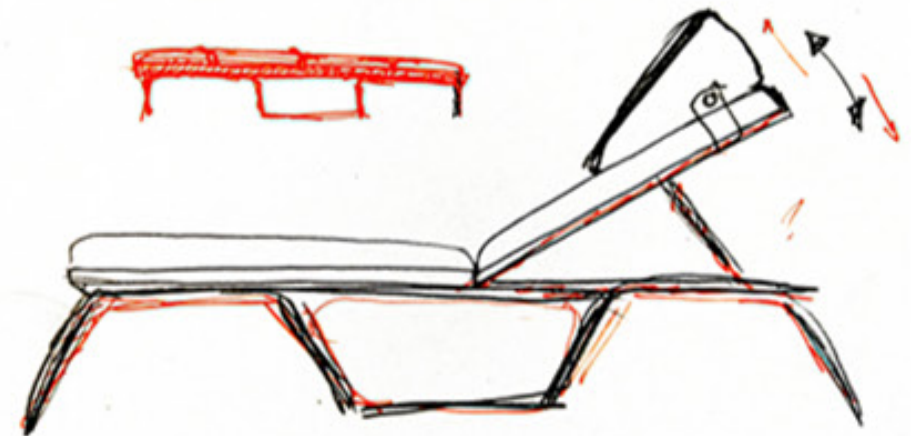
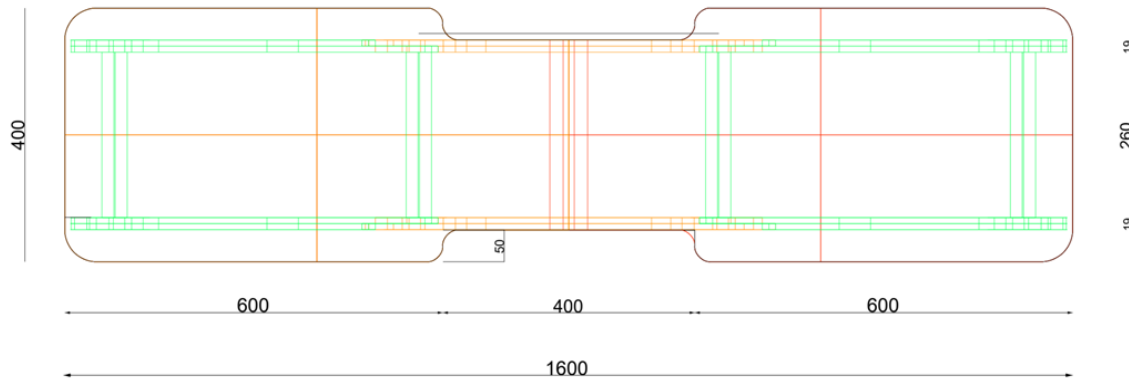

Figure 35. Abstract Sketch how the bench will look. By Carolina Mac-Iver

2.5.b First Technical Drawings

First Top View (Figure 36)



First Side View (Figure 37)

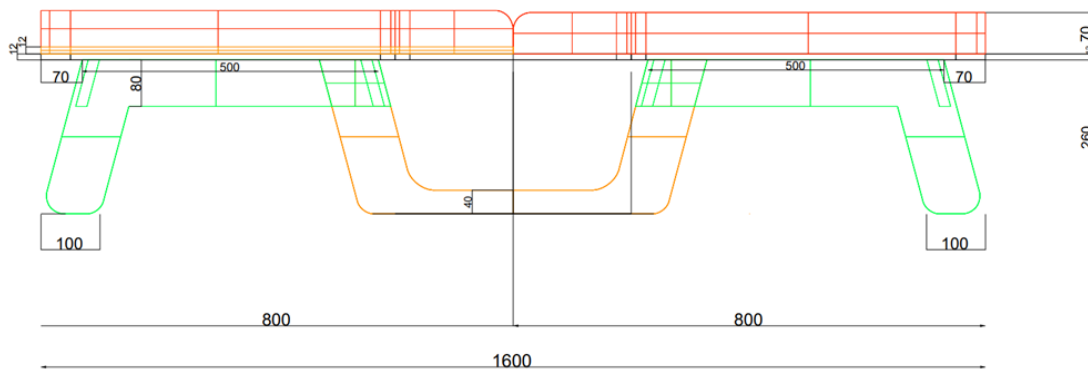

First Join System (Figure 38).

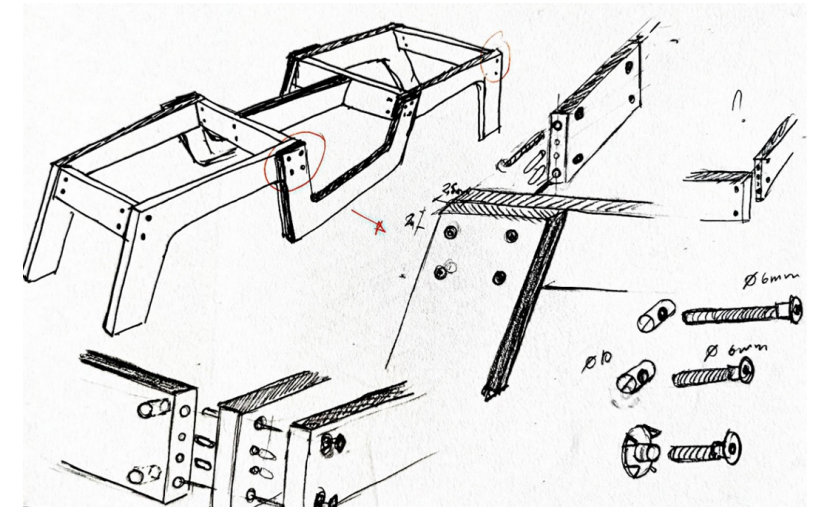

This 3 Technical Drawing. Those are the first drawings I made. As the process of design continued, these designs were modified (Figure 36-37). Only the join system was maintained. (Figure 38).

2.5.c Final Technical Drawings

Surfaces piece of the Bench in Plywood material. Drawing is in 2D ready to send to CNC machine. (Figure 39).

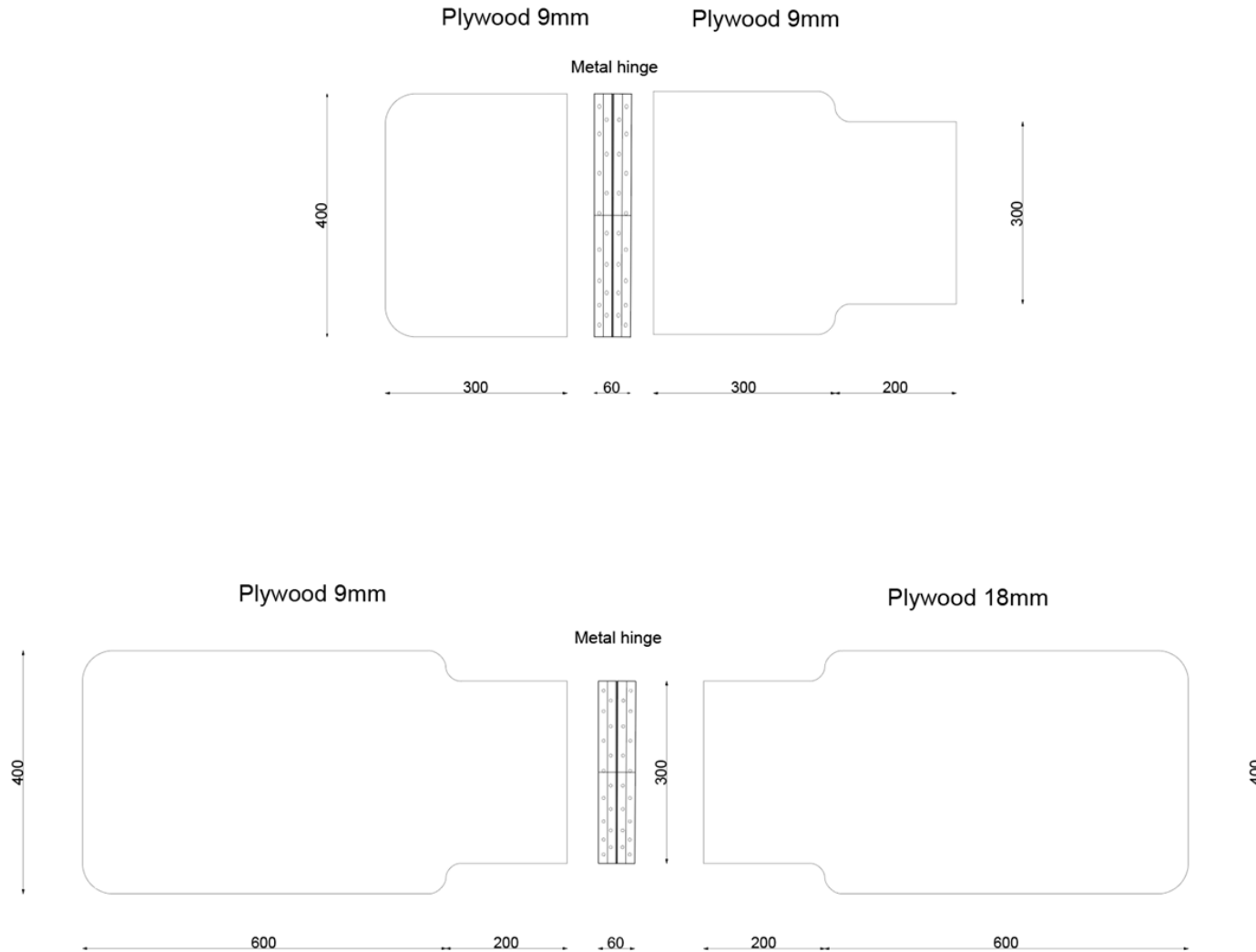

Figure 39

The structure of the legs is also drawing in 2D. Every piece has the holes for the screws and the dimension. The CNC machine will cut piece by piece on plywood 18 mm. (Figure 40).

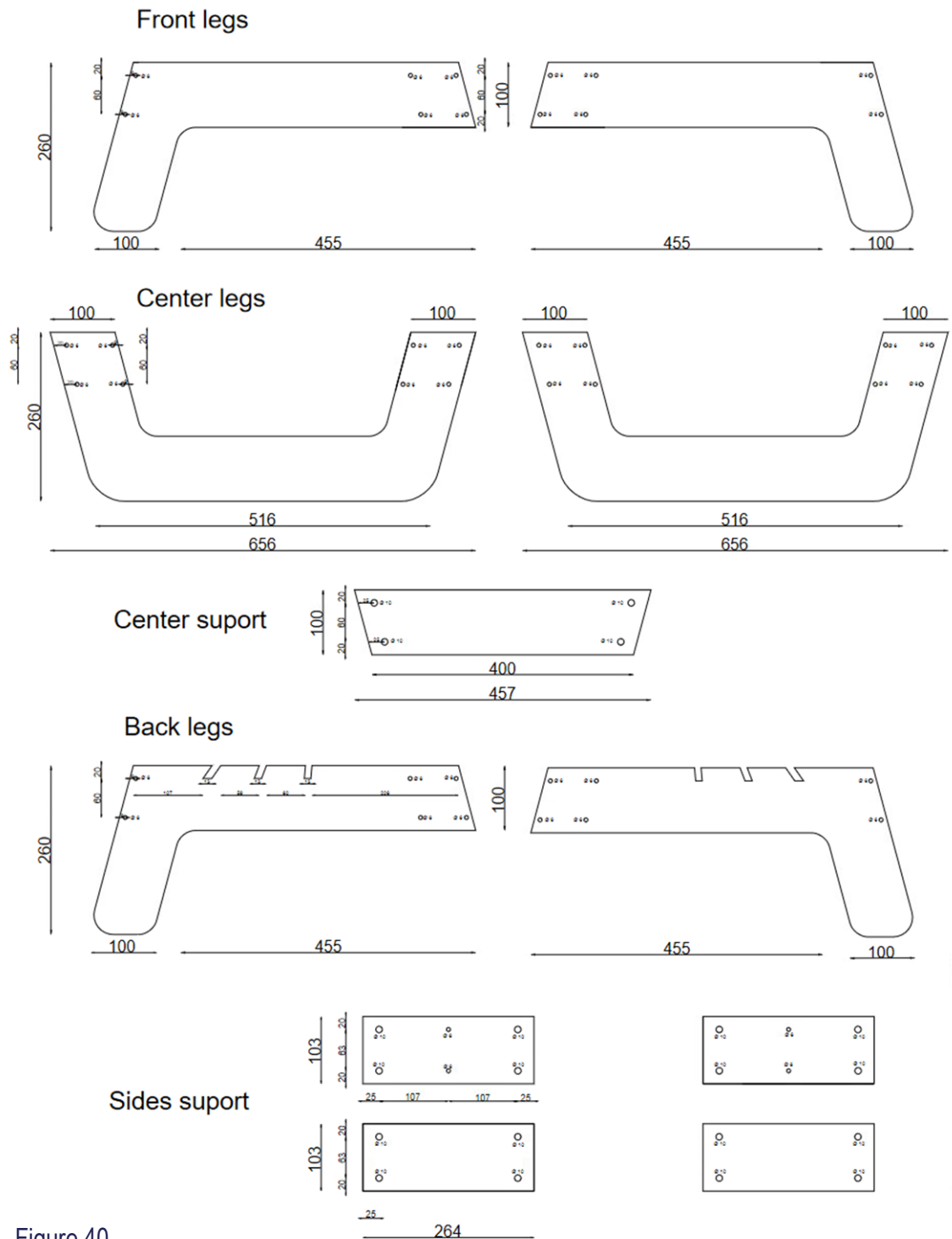

Figure 40

The model of the bench structure in 3d, looks like this one. The legs are also cutting by CNC machine. (Figure 41).

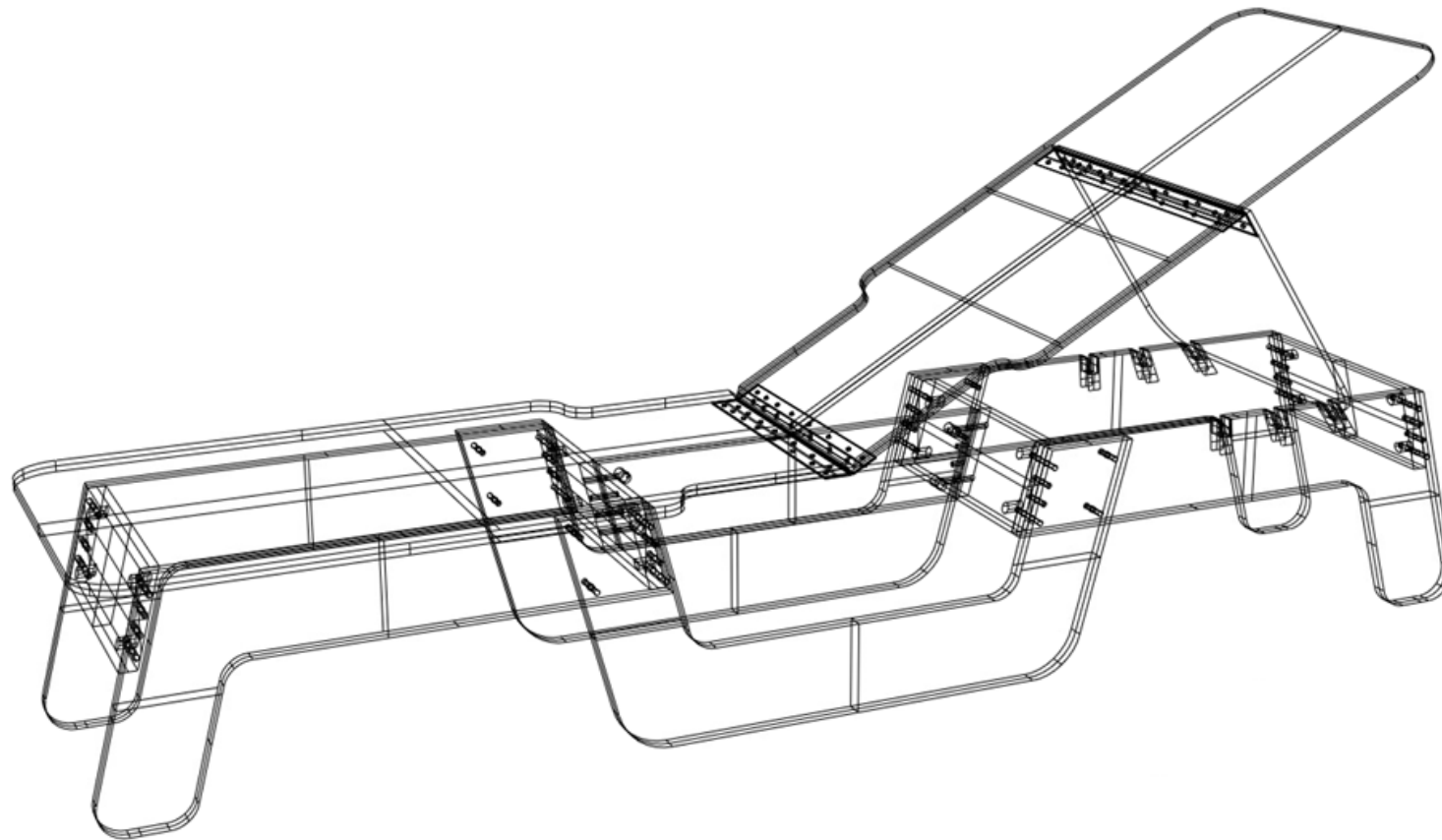
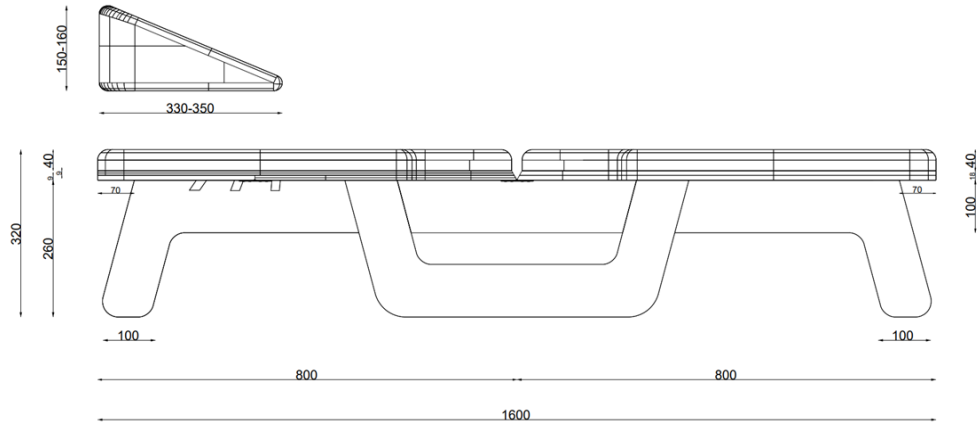

Figure 41

Side View



Top View

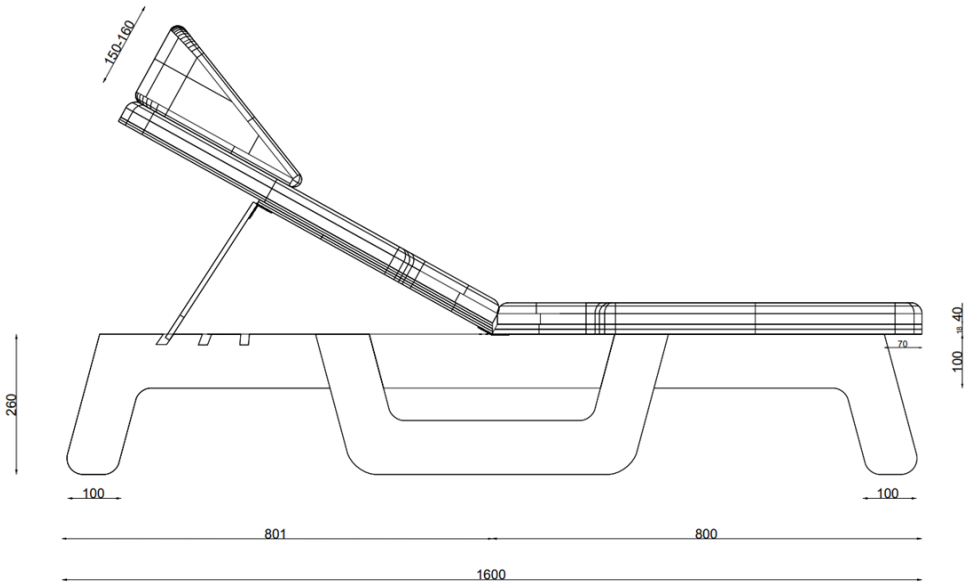
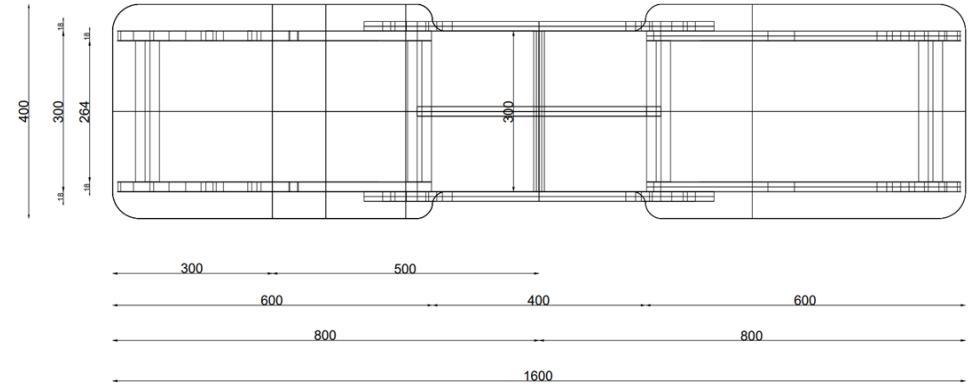

Figure 41. Final Technical views drawings.

2.5.d 3D Modelling Evolution

The designs develop has been in Rhino6 3d. The model has been modifying many times in all process looking the best possibility and shape. (Figure 42-46)



Figure 42. The first 3d modelling has narrow legs and one extra pillow under the surface.



Figure 43. At this point, I worked in more strong legs to support the weight of the person. I decide to delete the pillow under the bench.

Figure 44. In this 3d modelling, is possible see the change I did in the structure of legs. I added a piece of wood in centre to bring more resistance.



Figure 45. I put all legs the same 100 mm thickness and I added the surface which fits well on the frame of the legs. There is one hinge system to move up and down the back part of the bench.

Figure 46. In this last 3d modelling, is almost ready the final design of the bench structure in ply wood.



2.5.e 3D Final Modelling



Figure 46. 3D Final views of the bench



Figure 47. 3D Final view of the bench



Figure 48. 3D bench modelling in different possible colours

2.6 Prototype Materials

2.6 a. Structural Material

- a.1 Birch plywood 18 mm for leg structure, Lab wooden workshop, Koskisen Oy
- a.2 Birch plywood 18 mm and 9 mm for structural surface, Lab wooden workshop, Koskisen Oy
- a.3 Metallic hinge 400 mm x 380 mm, Lab wooden workshop
- a.4 Metallic hinge 300 mm x 380 mm, Lab wooden workshop
- a.5 Steel screws M6 x 80 mm, hand made in Lab metal workshop
- a.6 Steel screws M6 x 40 mm, hand made in Lab metal workshop
- a.7 Steel screws M6 x 60 mm, hand made in Lab metal workshop
- a.8 Wooden screw M8 x 30 mm, Lab wooden workshop
- a.9 Barrel nuts M6 x 20 mm, 20 units.
- a.10 Four serrated pronged T nuts steel M6, 8 units.
- a.11 Steel screws 10 mm large
- a.12 Wooden glue

2.6.b. Surface Material

- b.1 Sandpaper 220
- b.2 Osmo color Puuvaha, varnish and birch colour.

2.6.c. Mattress Materials

- c.3 Birch plywood 6 mm for mattresses part.
- c.4 Foam 40 mm HR35
- c.5 Cotton material
- c.6 Sorensen Leather, colour Spectrum Royal 30166
- c.7 Glue

The Mattress and pillow of the Bench had been made by upholstery company Verhoomo Palttina. I choose a leather material for the surface because I need a material easy to clean. This point is very important, because the bench must be cleaned after use. There are other materials for use more economic than leather, of course. But for this prototype, I select the colour and texture I liked it.

2.7. Prototype Building Process

2.7.a Cutting pieces of Koskisen plywood in CNC machine at Lab wooden workshop (Figure 48-49).



Figure 48. CNC machine cutting the legs piece by piece.
Photo by Carolina Mac-Iver

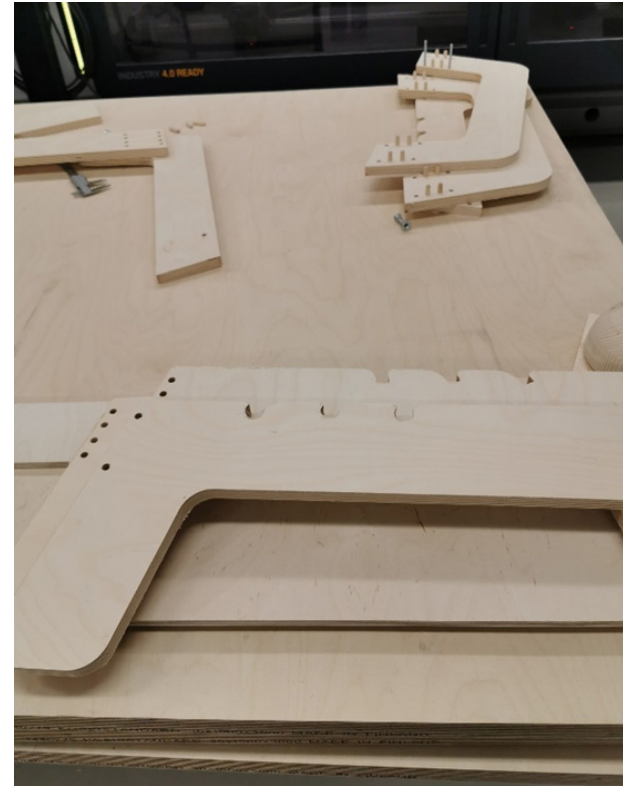

Figure 49. Legs cut by CNC machine with ready screw holes.
Photo by Carolina Mac-Iver

- First think I did, was meeting Hannu -Pekka Määttä who is the professional in responsible for wooden workshop and Vesa Damski to check the material available in school and timeless for work in workshop with professional supervision.
- Second, we choose the Koskinen birch plywood 18 mm and 9 mm.

- Third, I send by e-mail to Hannu-Pekka, the 3D model piece by piece with correct measurements and holes for CNC cut.
- Four, we cut the rectangular pieces where the final part of the bench would fit one by one.

2.7.b Handmade screw for the bench in Lab metal workshop



Figure 50. Photo taken by Carolina Mac-Iver at Lab metal workshop.

I made myself most of the screw in my project. How the type of screw I need it for my project were very difficult find, I did it a big part of them for myself in Lab Metal Workshop (Figure 50-51) The option was order from HAFELE in Germany, but I skip that option because for corona restriction delivery time can be long.



Figure 51. Photo taken by Carolina Mac-Iver at Lab metal workshop.

So, I went to HelaKauppa, screw store in Helsinki, and I bought from there all pieces I need it to make my own screws. I made 8 steel screws M6 x 80 mm, 8 steel screws M6 x 40 mm and 8 screws M6 x 60 mm. All screws had also steel T nuts centric or four serrated pronged.

2.7.c Assembly test

Once all plywood pieces were cut and ready with screws. I assembled part by part to check if the parts were fit correct. (Figure 52-55).

First legs with still screws and wooden screws and then surfaces.



Figure 52 Legs of the Bench. Photo taken by Carolina Mac-Iver.

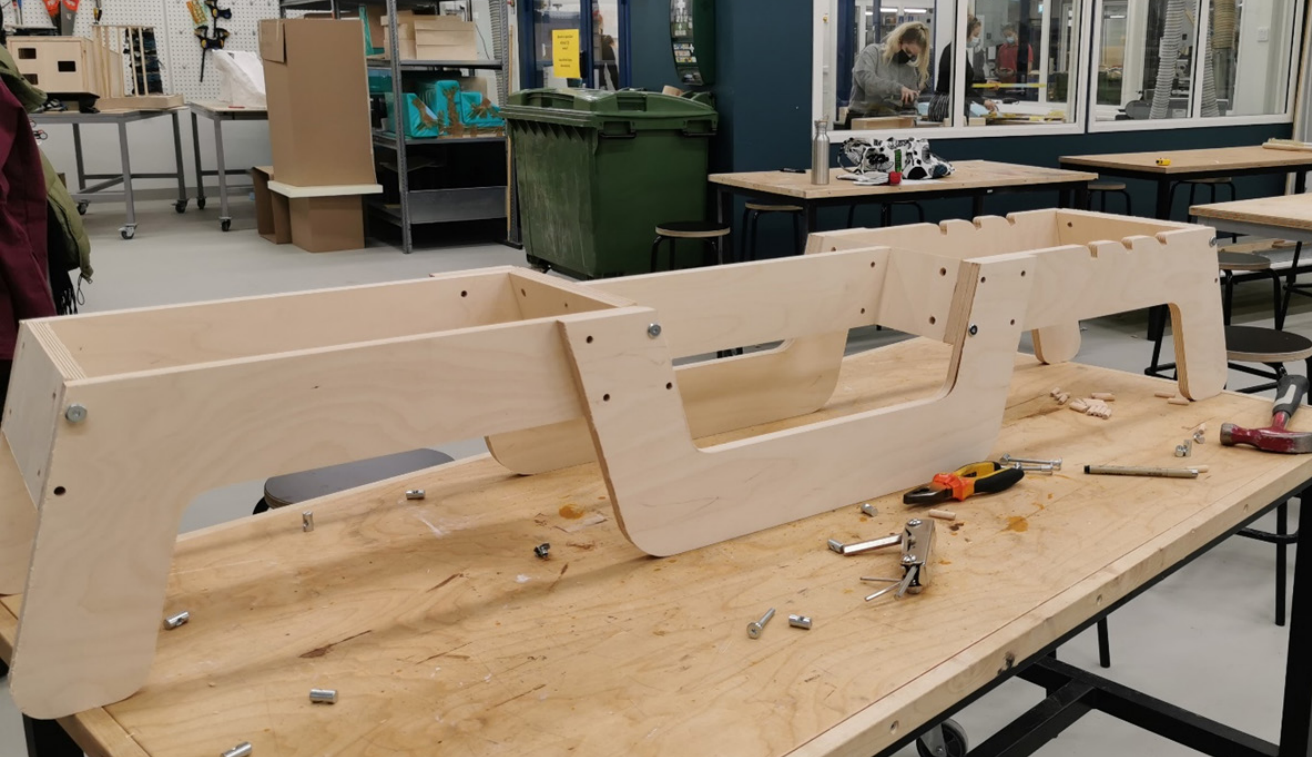

Figure 53. Assembly test of the bench in Lab wooden workshop.
Photo by Carolina Mac-Iver

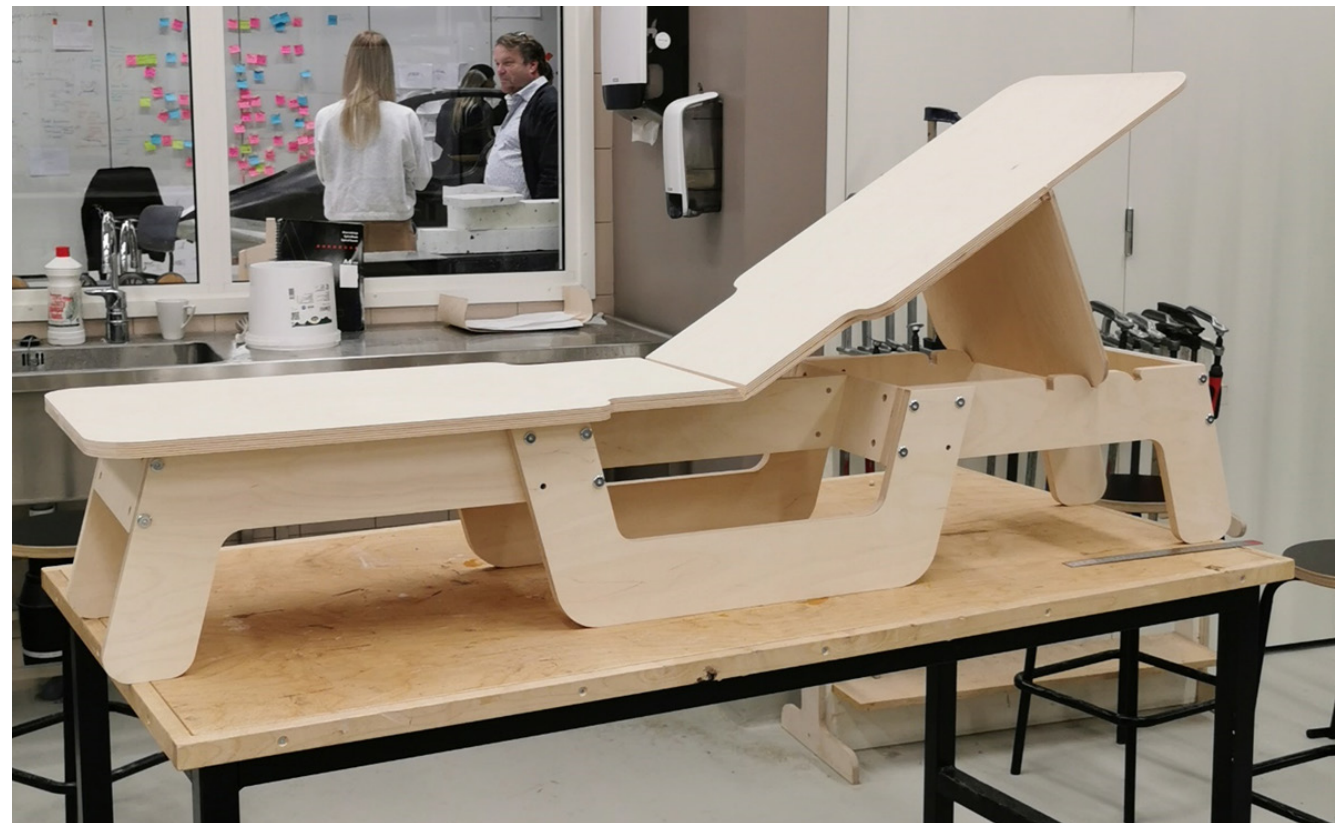

Figure 54. Assembly test of the bench in Lab wooden workshop.
Photo by Carolina Mac-iver.

Figure 55. Assembly test of the bench in Lab wooden workshop.



2.7.d The Sanding Work

For sanding step, I used sandpaper number 220 and manual school machine. The machine was for surfaces and manual sandpaper for the corners of the plywood to get a small curve angle. With machine sanding, I delete every mark and detail from cutting and the result was nice clean and soft plywood pieces. (Figure 56).



Figure 56. Sanding process. Photo by Carolina Mac-Iver at Lab Wooden workshop.

2.7.e Vanish Process

First step of Vanish

I choose Osmo Birch oil and colour for my prototype. I cleaned piece by piece the sanding powder left on the plywood and then with a clean cloth apply the first layer of vanish. (Figure 57).



Figure 57. First step of vanish. Photo taken by Carolina Mac-Iver at Lab Wooden workshop.

Drying of the first layer of varnish

Once I varnished all pieces, I put it pieces by piece on the metal shelf and left there for 24 hours. (Figure 58).

After 24 hours and once the pieces were dry, once again I did the process of sanding, varnishing, and drying.



Figure 58. Dry process. Photo taken by Carolina Mac-Iver at Lab wooden workshop.

2.8.f Logistic

From the logistic point, the idea to have a bench in part, is very easy solution for transport way. When we think in design housing furniture, also is necessary think how we can transport it once is ready. (Figure 59).

I tried to do make a design, very easy for consumers, if this model goes to production in the future. Accessible cost, easy for industrial production, easy to assemble for consumers and easy to transport. (Figure 60).

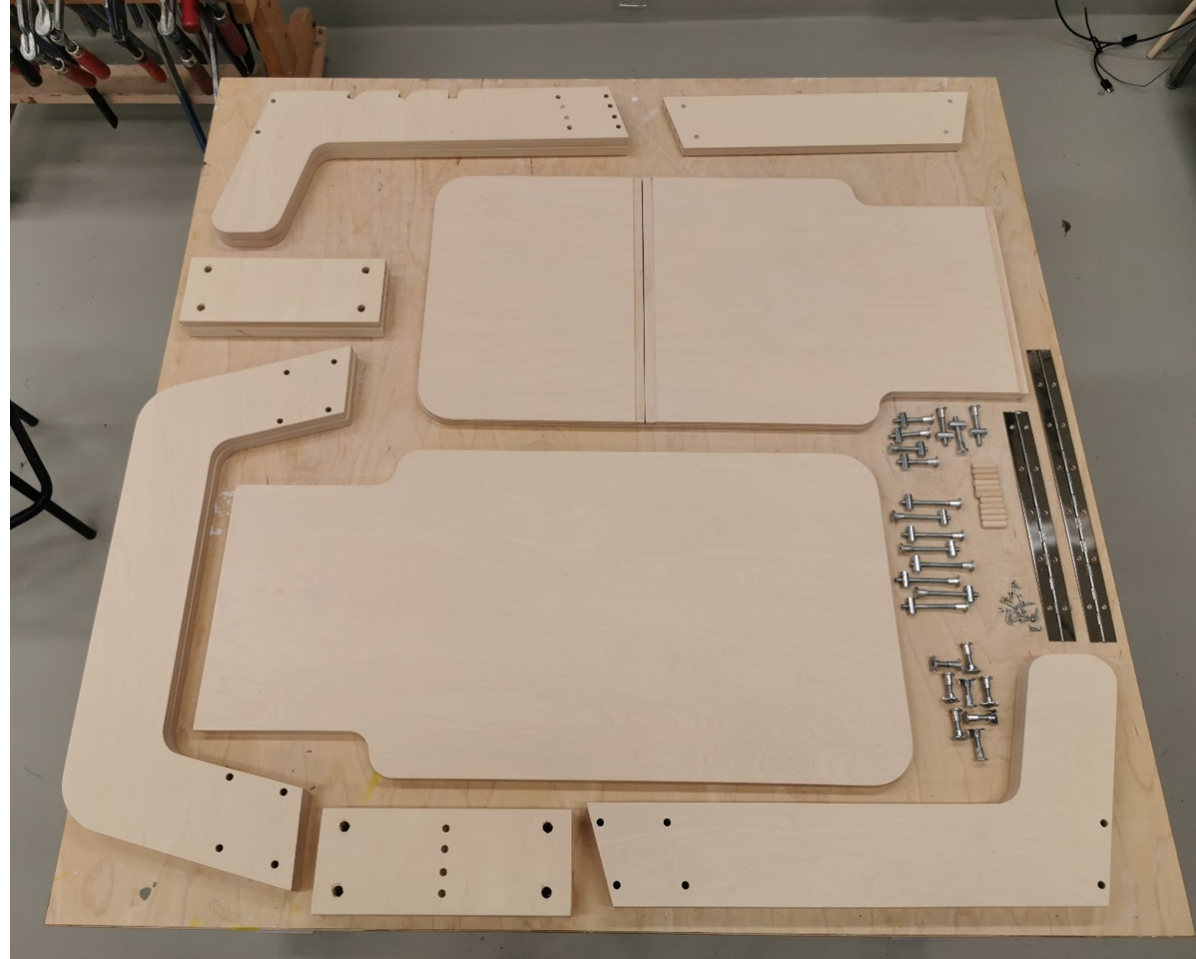

Figure 59. Photo taken by Carolina Mac-Iver at Lab wooden workshop.



Figure 60. Photo taken by Carolina Mac-Iver.

Of course, in this stage of the work, the mattress part is not ready yet, but if I would have to packing the bench in a cardboard box for transport, would be like this Figure 60.

2.9 Mattress

2.9.a Mattress Structure

To make a nice mattress for my bench, I choose the company Verhoomo Paltina and I went to have meeting with them and have a discussion how can be dawn according to what I want.

The first thing was necessary to cut two pieces more this time, of birch plywood 6 mm copying the shape of the bench. The Verho company did not do that work, so I cut it and bring ready for them.

Then choose the material of the surface. I have clear idea than fabric was not an option. In this case, I wanted to have a material easy clean, and I choose leather in blue colour, because leather is soft and worm when it is touch. (Figure 61).The blue colour is elegant, it is a neutral colour, and match very nice with birch plywood.



Figure 61. Sorensen Leather, colour Spectrum Royal 300166. Photo taken by Carolina Mac-Iver at Verhoomo Paltina.

The foam used in my bench is Foam 40 mm HR35. Looking how fit on top of the birch 6 mm and have decision about how we must cut it. One thing is how we designed in 3D program; another is how looks at real.(Figure 62).



Figure 62. Foam 40 mm on top of birch ply wood 6 mm. It was necessary cut an curve in the join where the bench flip.

The build of the mattress is according to the sketch. The foam will be glued to the plywood base 6 mm and the leather is covering the cotton and foam. This leather goes around to the mattress to join the material with screws from the back part of the plywood 18 mm.(Figure 63).

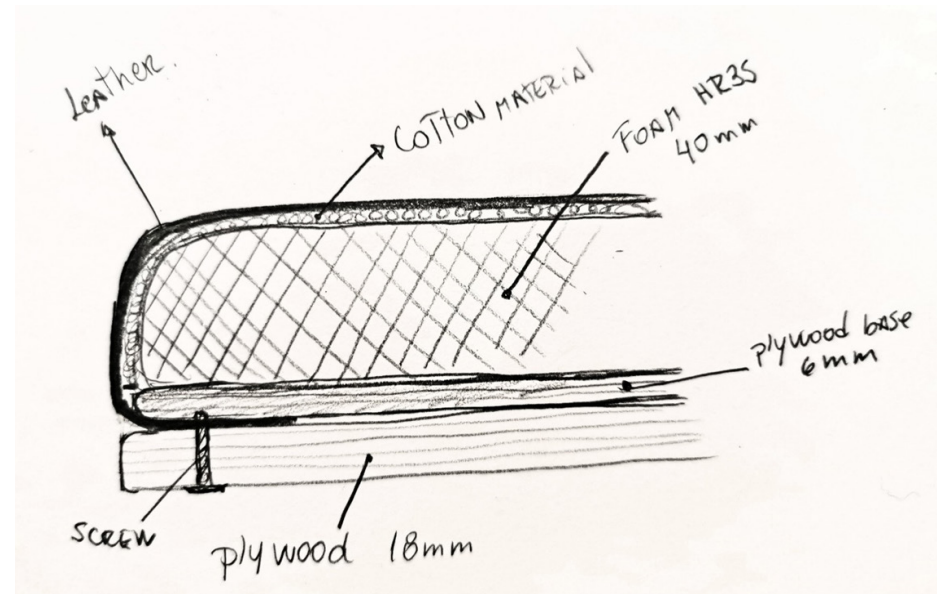

Figure 63. My handmade sketch of the section of the mattress part of the Bench.

There was 2 different possibilities to put the leather on the bench (Figure 64).

1. In one piece leather, with some seams in the angles where the shape of the bench is curve.
2. In two pieces, so there is an surface part of leather and another piece in the side parts of the mattress.

I choose the second option, because if we have 2 pieces the shape kept in nicer than the first option. My bench has curves angles in every border. With his second option, the seams are nicer and keep more the curve shape.

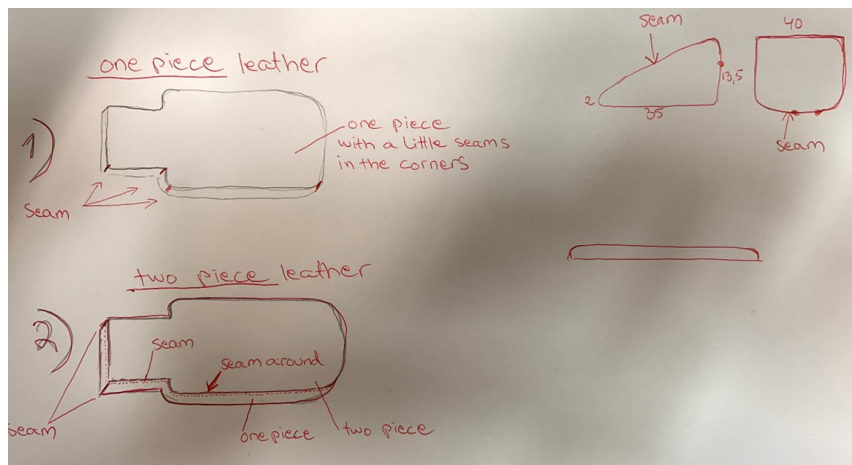

Figure 64, Sketches made by Verhoomo paltina, to choose how the leather can be.

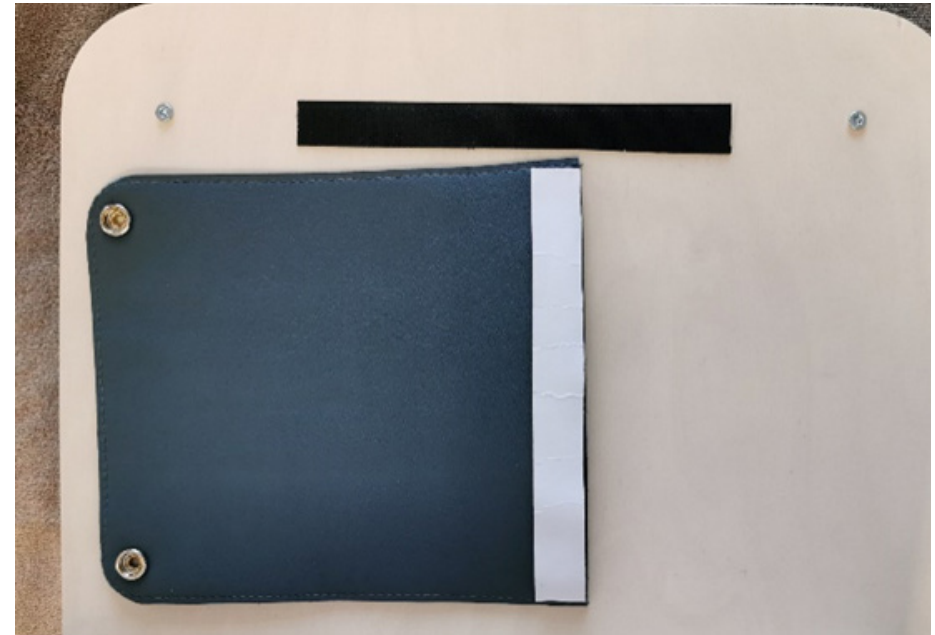

Figure 65. Photo taken by Carolina Mac-iver.

The pillow accessory has the same cover leather, but has double foam inside, just get more density. There is Velcro in plywood. So, it is possibly taken away when is need it.(Figure 65).

2.9 Put all parts together

I started to screw the piano hinge in both parts in the bench flip. (Figure 66).

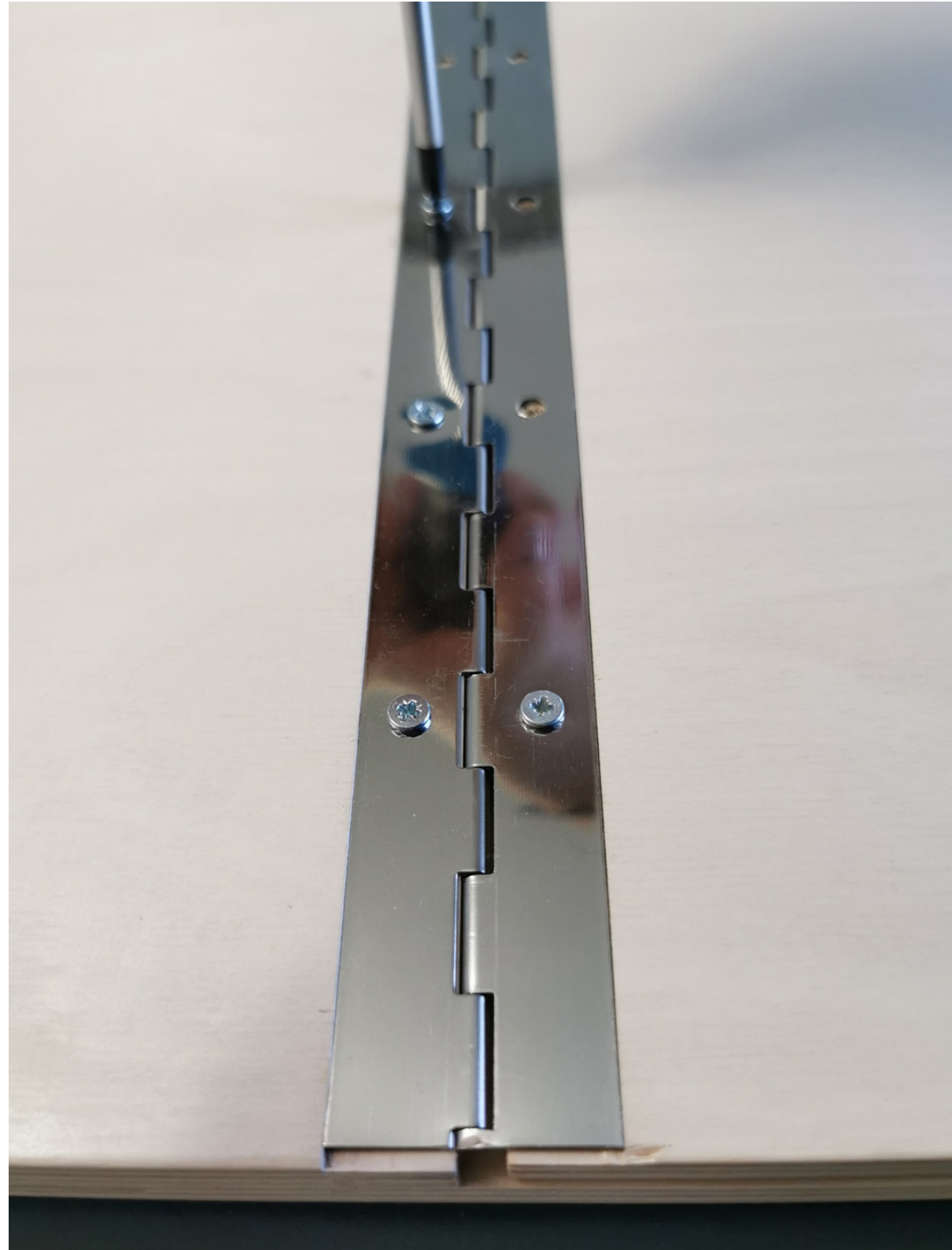

Figure 66 Photo taken by Carolina Mac-Iver



Figure 67. Join the legs with the sitting part of the furniture with screws and brackets. The bench is almost ready. Photo by Carolina Mac-Iver.

3 FINAL PROTOTYPE



Figure 68. Final photo by Jonne Heinonen



Figure 69. Final photo by Jonne Heinonen



Figure 70. Final photo by Jonne Heinonen



Figure 71. Final photo by Jonne Heinonen



Figure 72. Final photo by Jonne Heinonen



Figure 73. Final photo by Jonne Heinonen



Figure 74. Details photos of the bench by Jonne Heinonen

3.1 Conclusion

My thesis work was about design a new concept of housing furniture. During the thesis process, I explained how the sexual relation act also need furniture to bring comfort at home us like bed bring comfort for sleep or dinning table bring comfort for eat.

This new concept I made, mix two possibilities of how we can use this bench at home. So, it is not necessary hide the furniture begins the curtain when the guest are visiting us. This bench can be part of the house. This is possible because the design shape, materials and quality of the furniture is aesthetically beautiful. For this purpose, I used in the building process natural and warm materials like for example Finnish birch plywood and leather.

The bench worked us like normal seating place and also bring comfort for couples for sexual relationship.

There was a challenge for me do the whole operation. I started with the idea and then the rest came step by step for while the process continued.

I am glad about result I got. I am satisfied with all research of ergonomics I made in the process of the thesis. The building work result is very near of a final prototype too. I noticed, can be necessary for the next level of prototype put one more strong hinge in the bent joints.

Could be possible used another materials like solid wood for example oak, pine, cherry or walnut.

3.2 List of References

1. Dra. Shannon Chavez Qureshi, Clinical Psychologist and Certificate Sex Therapist from Los Angeles, web address:
<https://drshannonchavez.com>
2. Sarah Deysach, Sex educator, mentioned in web article "Why the Sexologist Recommend Sex Furniture for a better love-life. Web address : <https://loverollers.com/love-sex-relationship/why-do-sexologists-recommend-sex-furniture-for-a-better-love-life/>
3. Sex Design-Brainstorming Book (Spanish edition); ISBN-10:8493211648. ISBN-13:9788493211646; Author: Ubeda Ramon; Published by Linea Editorial 2004.
4. Erotic Furnitures Wikipedia. Web address: <http://en.wikipedia.org/wiki/erotic-furniture>
5. Jon Knowles, How Sex Got Screwed Up: The Ghost that haunts Our Sexual Pleasure-Book written and illustrated by Jon Knowles. Edited by Christofer Reed (2019).
6. Wilson, J.R., Corlett, E.N., New Methods in Applied Ergonomics (London: Taylor and Francis).
7. International Encyclopedia of ergonomics and human Factors Volume 1-2-3. edited by Waldemar Karwowsky. University of Louisville Kentucky, USA.
8. Sue Brayne; Sex Meaning and the Menopause. A book for Men and Women, first published 2011 by Continuum International Publishing group, London.

4 APPENDICES

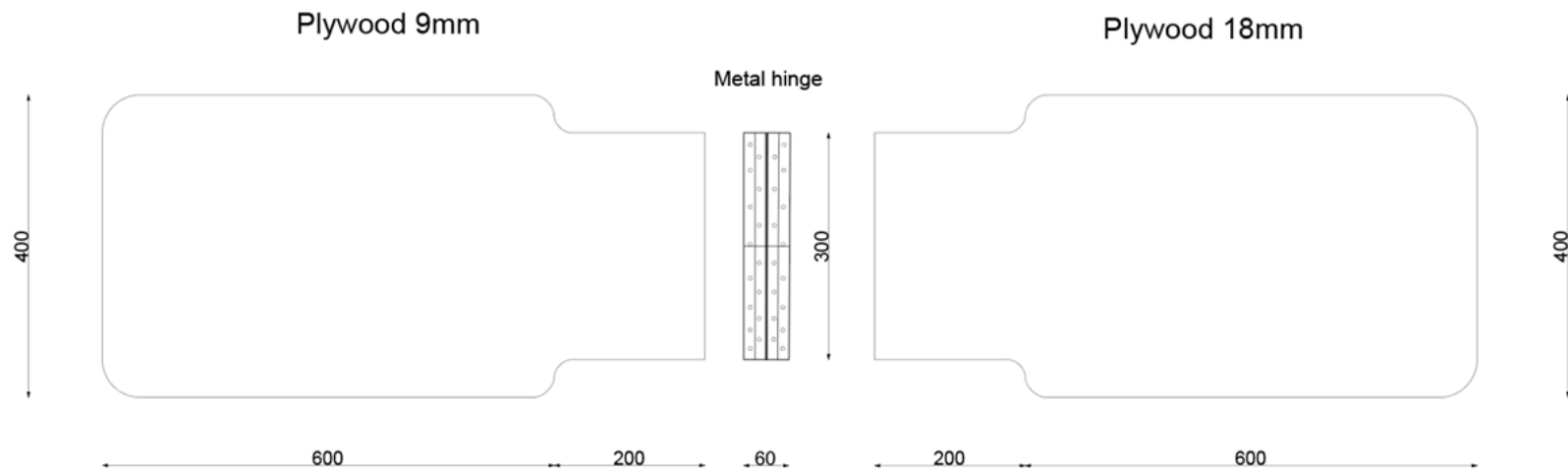
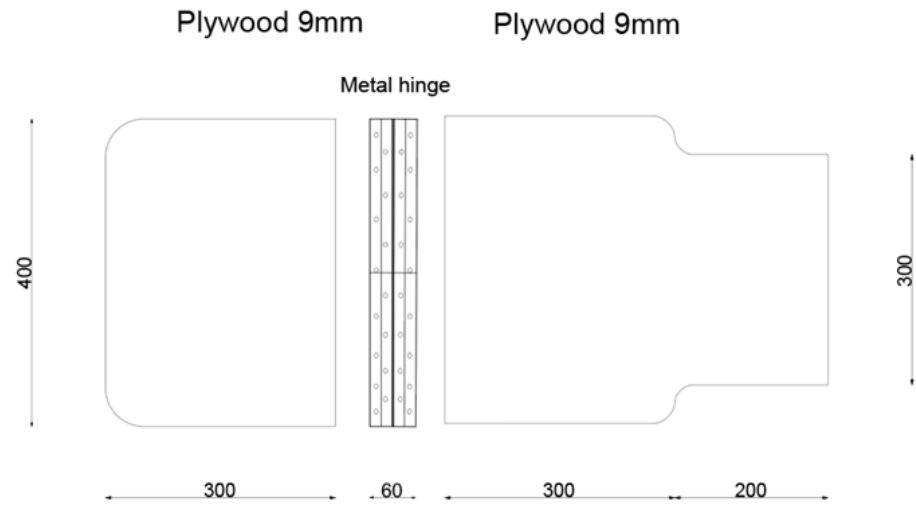

Appendices 1.

Surface of the Indigo bench 1:20

Drawing: November 2021

Author: Carolina Andrea Mac-Iver Gonzalez

Front legs

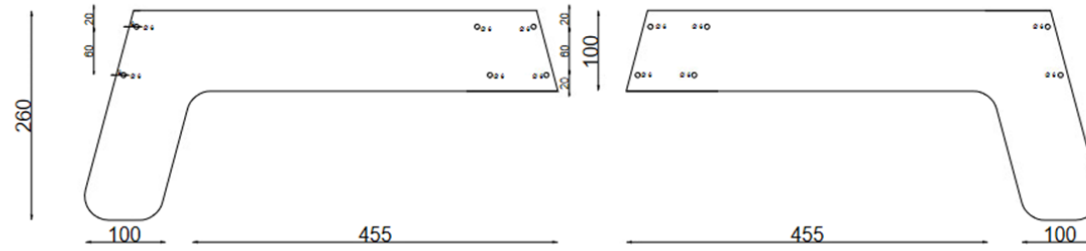

Center legs

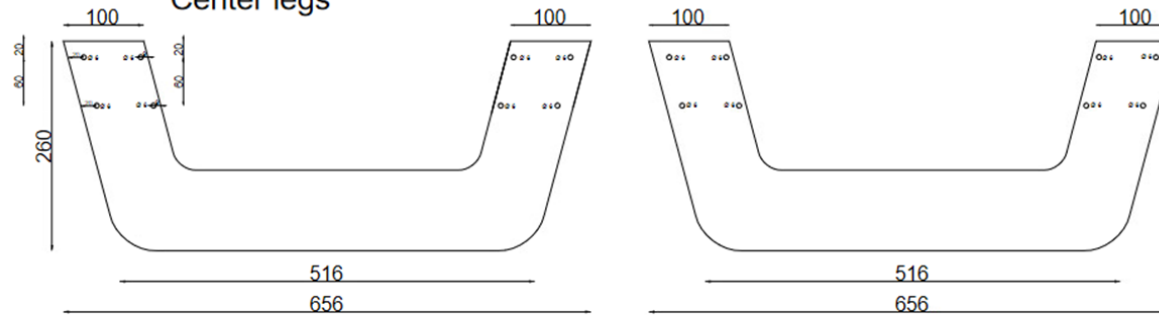

Center suport

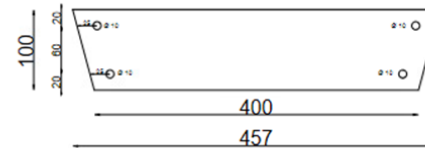

Back legs

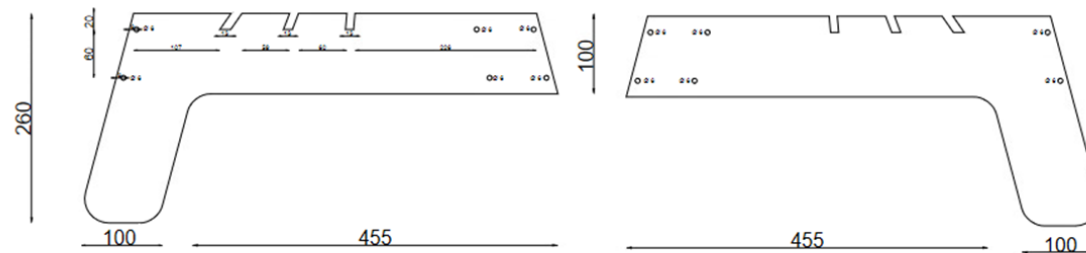

Sides suport

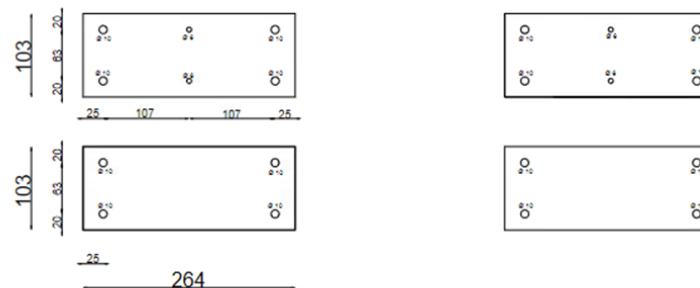

Appendices 2.

Frame legs of Indigo Bench 1:20

Drawing: November 2021

Author: Carolina Andrea Mac-Iver Gonzalez

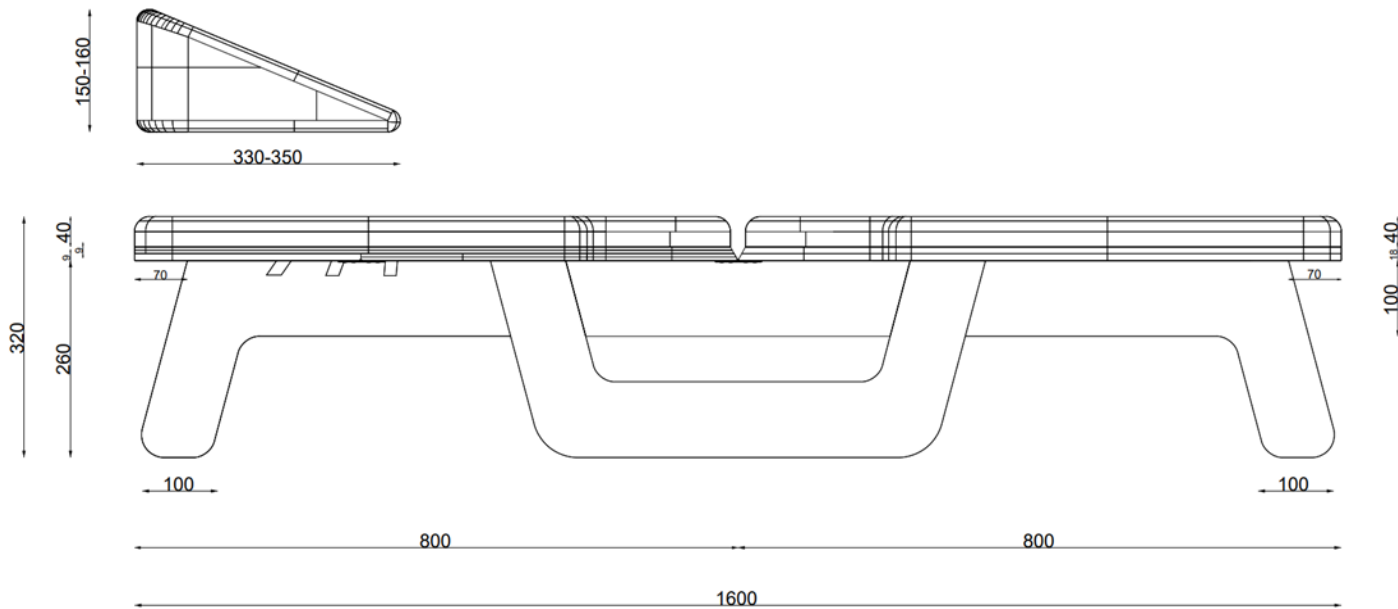

Appendices 3.

Side View, Indigo Bench 1:20

Drawing: November 2021

Author: Carolina Andrea Mac-Iver Gonzalez

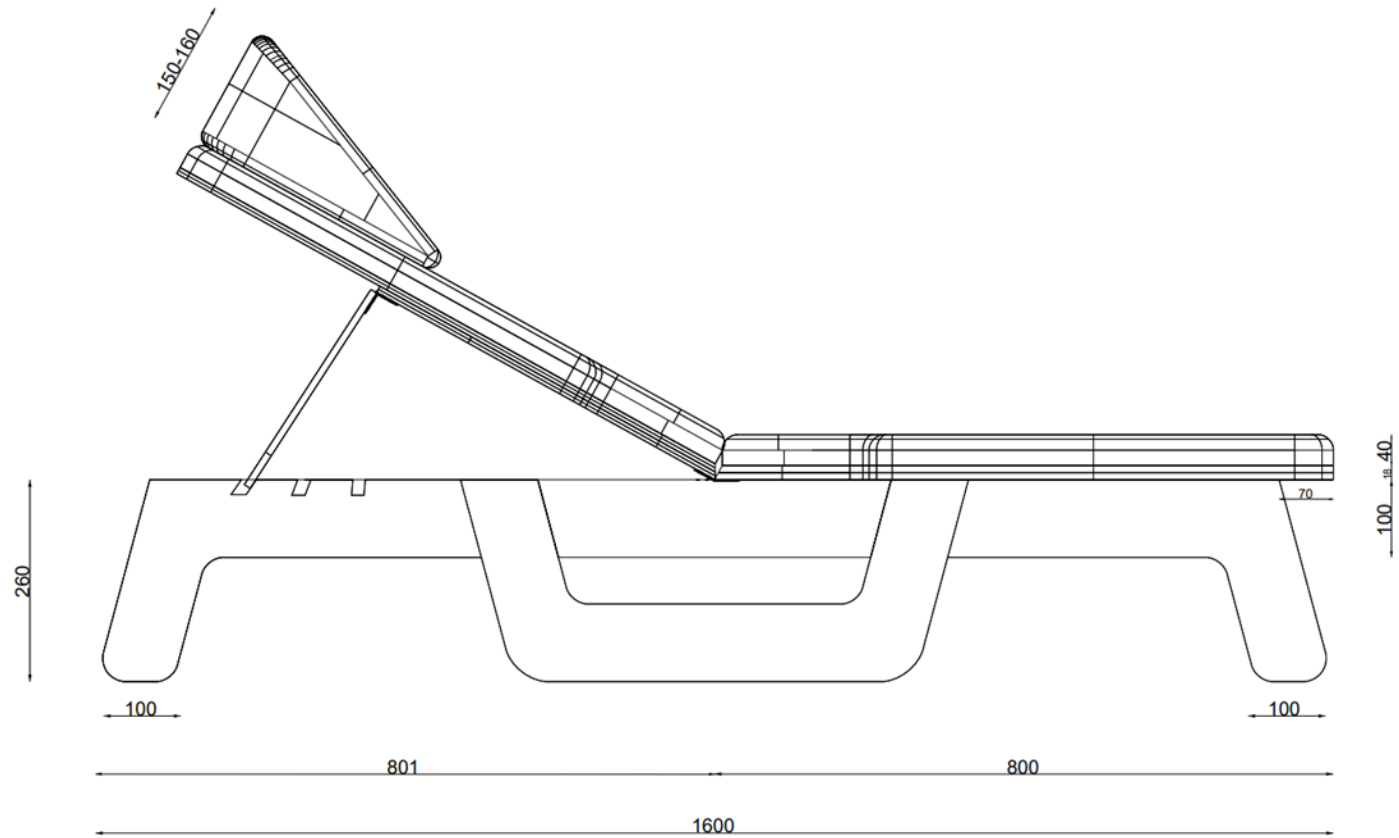

Appendices 4.

Side View, with back up, Indigo Bench 1:20

Drawing: November 2021

Author: Carolina Andrea Mac-Iver Gonzalez

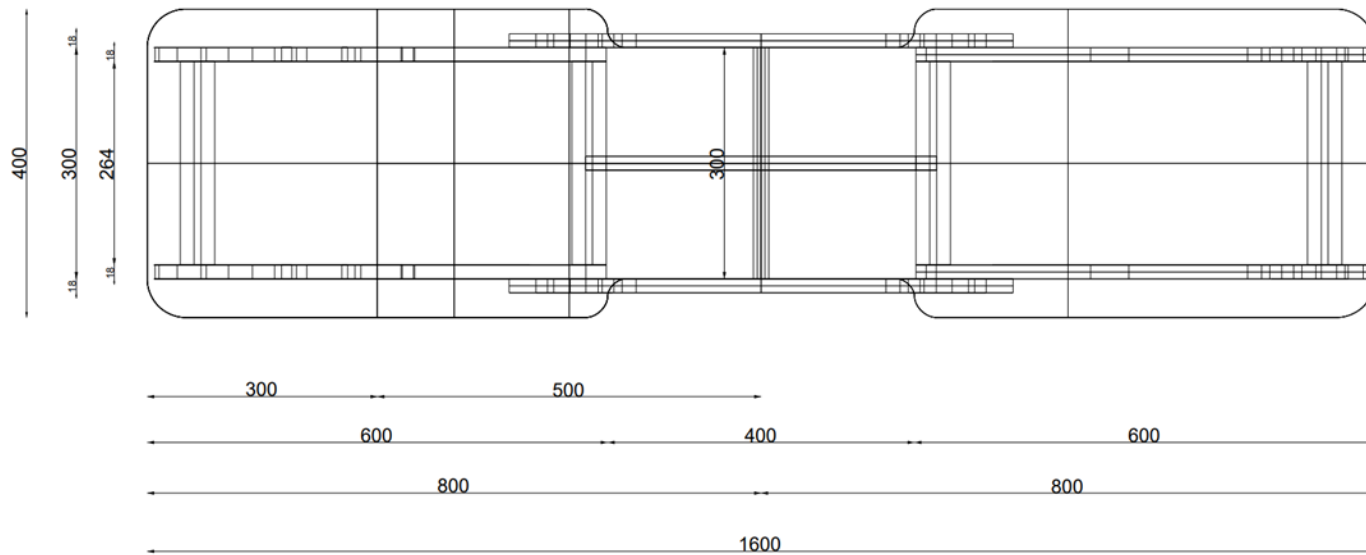

Appendices 5.

Top View ,Indigo Bench 1:20

Drawing: November 2021

Author: Carolina Andrea Mac-Iver Gonzalez

Thank You

To the Interior Design teacher Sari Anttonen and special to my tutor Vesa Damski and Hannu-Pekka Määttä from Lab wooden workshop who were helped me in whole thesis process and prototype building project.

To the professionals, and people who helped me with interviews and information.

To my family and relatives.

To Verhoomo Paltina, for made a beautiful mattress us I designed.

One special mention, to my young brother Jorge Enrique Mac-Iver Gonzalez, who was my inspiration and who pushed me to make this idea real, always thinking though the relationship between Design and Human Physiognomy.

Jorge Enrique Mac-Iver Gonzalez
Kiniesiology and Physyotherapist

(1990 - 2021)