

Markku Sahakangas

Planning of an electric system for a small CNC machine

Thesis

Spring 2015

SeAMK School of Technology

Automation Engineering



SEINÄJOEN AMMATTIKORKEAKOULU
SEINÄJOKI UNIVERSITY OF APPLIED SCIENCES

SEINÄJOKI UNIVERSITY OF APPLIED SCIENCES

Thesis abstract

Faculty: School of Technology

Degree program: Automation Engineering

Specialisation: Electric Automation

Author: Markku Sahakangas

Title of thesis: Planning of an electric system for a small CNC machine

Supervisor: Martti Lehtonen

Year: 2015

Number of pages: 40

Number of appendices: 4

As a part of SeAMK Digital Factory a project named Pilottituote was carried out. Its aim was to plan and manufacture a small-scale CNC milling machine. The machine was planned to have three linear axes and a separate control system. In this thesis the machine's electrical system was designed, components were chosen and the relevant documents were produced. In the thesis the basic principles of CNC machines, different components' functions and relevant standards are studied.

As a result, right kinds of components were selected to achieve the desired functions. An electric circuit and layout documentation, as well as a PL security classification were made for the machine. The required electrical system components were ordered and the electric system of the machine can be wired and assembled on the basis of the documentation.

Key words: CNC, electric, planning

SEINÄJOEN AMMATTIKORKEAKOULU

Opinnäytetyön tiivistelmä

Koulutusyksikkö: Tekniikan yksikkö

Tutkinto-ohjelma: Automaatiotekniikka

Suuntautumisvaihtoehto: Sähköautomaatio

Tekijä: Markku Sahakangas

Työn nimi: Pienen CNC koneen sähköjärjestelmän suunnittelu

Ohjaaja: Martti Lehtonen

Vuosi:2015

Sivumäärä: 40

Liitteiden lukumäärä: 4

Osana SeAMK:n Digital factory hanketta toteutettiin Pilottituote niminen projekti. Sen päämääränä oli suunnitella ja valmistaa pienen kokoluokan CNC jyrsinkone. Koneeseen suunniteltiin 3 lineaarista akselia ja erillinen ohjausjärjestelmä. Tässä työssä suunniteltiin kyseenomaiselle koneelle sähköjärjestelmä, valittiin komponentit ja laadittiin asiaankuuluvat dokumentit. Työssä tutustuttiin pintapuolisesti CNC koneiden periaatteisiin, eri komponenttien toimintaan ja asiaankuuluviin standardeihin.

Työn tuloksena saatiin valittua oikeanlaiset komponentit, joilla saavutetaan halutut toiminnot. Sähköjärjestelmästä tuotettiin sähkö- ja layoutkuvat sekä tehtiin PL turvaluokittelu. Sähköjärjestelmään vaaditut komponentit tilattiin ja dokumentoinnin perusteella sähköjärjestelmä voidaan johdottaa ja kasata.

Avainsanat: CNC, sähkö, suunnittelu

TABLE OF CONTENTS

Thesis abstract.....	2
Opinnäytetyön tiivistelmä.....	3
TABLE OF CONTENTS	4
TABLE OF FIGURES	6
TERMS AND ABBREVIATIONS.....	7
1 INTRODUCTION	9
2 BASICS.....	10
2.1 SeAMK.....	10
2.2 CNC	10
2.3 Electric planning.....	13
3 MACHINE DESCRIPTION	15
3.1 Functional description	16
3.2 Safety.....	17
3.2.1 Performance level (PL)	17
3.2.2 Safety functions	19
3.3 I/O definition.....	19
4 HARDWARE	21
4.1 PLC	21
4.2 I/O	22
4.2.1 Digital input and output terminals.....	23
4.2.2 Safety Logic controller and Safety I/O terminals.....	23
4.2.3 Motors and motor drives	24
4.2.4 Inputs	28
4.2.5 Outputs	30
4.3 Power supplies.....	30
4.4 Enclosure.....	30
4.5 Connectors.....	31
5 CIRCUIT AND LAYOUT PLANNING.....	33
5.1 Circuit planning	34
5.2 Layout planning.....	35

6 CONCLUSIONS.....	36
BIBLIOGRAPHY.....	37
APPENDICES	39

TABLE OF FIGURES

Figure 1. Linear movement system.....	11
Figure 2. Construction of CNC system.....	12
Figure 3. Small milling machine (GRABCAT, 2012).....	15
Figure 4. Table and work piece on two servo driving mechanisms.....	16
Figure 5. SISTEMA software	18
Figure 6. Beckhoff CX5120 - Embedded PC	22
Figure 7. I/O terminals and Safety PLC EL6900	24
Figure 8. Beckhoff 8131 servo motor	26
Figure 9. Beckhoff EL7211-0010	27
Figure 10 The embedded PC with all the terminals and servo motors.....	28
Figure 11 Mounting example of cylindrical inductive proximity switch.....	29
Figure 12 Circuit diagram drawing example.....	34

TERMS AND ABBREVIATIONS

A	Ampere, the SI base unit of electric current
AC	Alternating current, a type of electrical current where the current repeatedly changes direction
CAD	Computer aided design, a wide range of computer-based tools that assist engineers, architects and other design professionals
CNC	Computer numerical control, a computer controller that reads instructions and drives a machine tool
DC	Direct current, the unidirectional flow of electric charge
DVI	Digital Visual Interface, a video interface for digital displays
HDMI	High-Definition Multimedia Interface, a proprietary audio/video interface
I/O	Input/output, a system of communication for information processing systems
IP	Ingress Protection Rating, an equipment protection classification scheme
MMI	Man-machine interface or user interface
NC	Normally closed, an electrical switch where the default position is closed
NC	Numerical control, a method of automatic operation of machine tools

NCK	Numerical Control Kernel, motion handling part of a CNC system
NO	Normally open, an electrical switch where the default position is open
PL	Performance class, safety integrity classification
PLC	Programmable logic controller, a digital process controller
PLr	Required performance class
rpm	Revolutions per minute
SIL	Safety Integrity Level, a measurement of performance required for a Safety Instrumented Function
USB	Universal Serial Bus, a computer bus standard
V	volt, the SI unit used to quantify any electric potential difference
W	SI derived unit for power

1 INTRODUCTION

When designing an electric system for a machine, there are a many factors to take into account. To design a good system, the basic principles of the machine must be studied and different solutions compared to achieve the wanted functions in the set requirements. There are some regulations and standards, which restrict the building and designing of the system. In this thesis the basic principles of a CNC machine are studied and an electric system for a small CNC milling machine is designed. Also selection of components, safety classification and documentation are included.

2 BASICS

In this section the project and its organizer are introduced. Also an overview of essential basic principles and theories are covered, to help better understand the following sections.

2.1 SeAMK

Seinäjoki University of Applied Sciences or SeAMK is a multidisciplinary institution of higher education and an efficient actor in education and research, as well as in development and innovation in West Finland. SeAMK has a total of 4500 students and 400 staff members. The total value of research and development projects is over 5 million euros. The aim is to greatly promote research, development and innovation (RDI).

SeAMK Digital factory enhances teaching in the school of technology enabling the integration of separate periods of study to a more comprehensive, joint entity for multiple degree programs. The goal of the Digital Factory is to build a digital learning environment for automation, machinery, manufacturing and information technology teaching.

Pilottituote is a project of Digital factory, which translates to pilot product. The goal of the project is to design a small, somewhat portable, CNC milling machine. The purpose of the project is to test the concept of designing a machine with the help of modern virtual tools. First a 3D-model of the machine is designed and it is going to be tested and optimized virtually. The physical machine is build according to the designs.

2.2 CNC

Computer Numerical Control (CNC) is a computer assisted process to control general-purpose machines according to the instructions generated by a processor from numeric instructions. There are many different types of CNC machine tools,

which can be divided into two main groups: cutting machines and non-cutting machines. Cutting machines perform removal process to make a finished part. Examples of such machines are a milling machine and a turning machine. Non-cutting machines apply force to a blank material to change the shape of the blank material. A good example of this type of a machine is a press machine. Also welding-, painting-, and cutting robot systems can be classified as CNC machine tools.

Servo driving mechanism is a system that transforms the commands from NC to a linear machine motion (Figure 1), it can consist of a motor and a power transmission device. Commands from the numerical control cause the motor to rotate a ball screw. The rotation of the ball screw is transformed into a linear movement of a nut, which is fixed to the table with the work piece. A servo driving mechanism controls the velocity and torque of the table via the servo driving device of each axis based on the velocity commands from the NC (Suk-Hwan, Seong-Kyoon, Dae-Hyuk & Stroud 2008, 3-9).

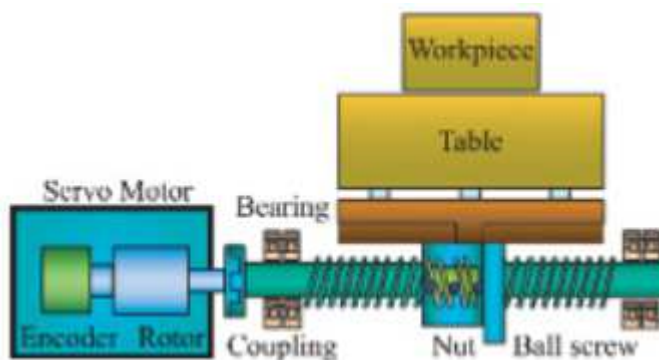

Figure 1. Linear movement system
(Suk-Hwan, Seong-Kyoon, Dae-Hyuk & Stroud 2008, 8)

Encoder is a device that detects the angular position and sends the information to the control system. It is usually fixed into the shaft of the power-transmission or integrated in the motor. In order to control the velocity, it must be measured. Velocity can be measured by a sensor or calculated with the position control data from an encoder (Suk-Hwan, Seong-Kyoon, Dae-Hyuk & Stroud 2008, 8). Encoders can be classified in two main categories: absolute- and incremental encoders. Absolute encoders give the actual angular position and incremental encoders detect changes in rotation (Bolton W. 2008, 34).

A CNC system consists of three parts (figure 2):

1. Man Machine Interface or MMI, which offers user interface for monitoring and operating the machine.
2. Numerical Control Kernel or NCK. It interprets a part program and calculates both the position to which the axes move, and the displacement of axes. It also controls the axis movement and smooths the acceleration and deceleration.
3. Programmable Logic Controller or PLC, which controls the machine behavior (excluding servo control) by carrying out a sequence program and communicating with the NCK.

(Suk-Hwan, Seong-Kyoon, Dae-Hyuk & Stroud 2008, 19-31)

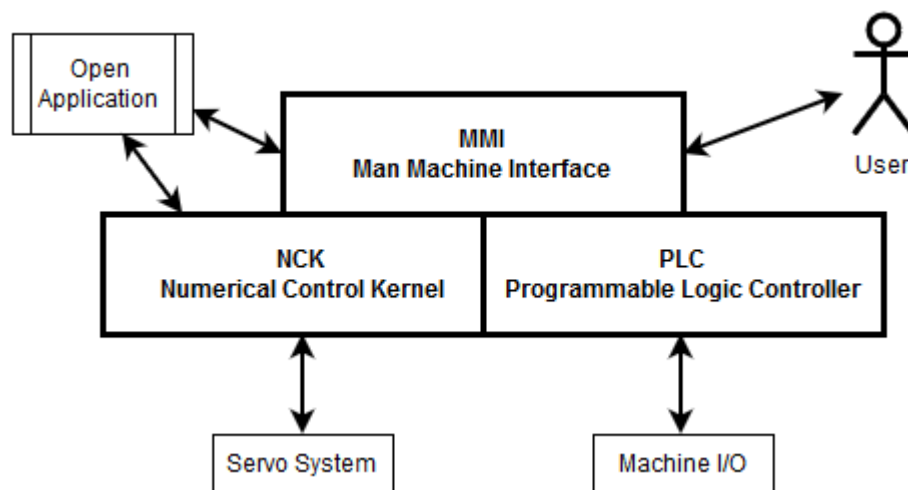

Figure 2. Construction of CNC system

A programmable logic controller is a special microprocessor based controller which can store instructions and functions such as logic, counting and timing to a programmable memory. Typical applications are controlling machines and processes. Input devices, such as, sensors and switches, and output devices in the system being controlled, such as motors and valves, are connected to the PLC. The operator then creates a program into the memory of the PLC. The PLC then monitors the programmed program (Bolton W. 2006, 3).

2.3 Electric planning

Electric planning is always needed in some form when a device, system, machine, building or premises need electric power to work. In modern devices, the apparatuses and the systems also involve more and more information technology applications and data transfer. The goal of planning is to understand practical needs and to implement electrical engineering according to them. A technical electric designer finds technical solutions to meet the customer's wishes and needs in accordance with the given resources. He documents the solutions using for example drawings, diagrams, directories and reports (Neuvottelevat Sähkösuunnittelijat NSS ry & Suomen Sähkö- ja teleurakoitsijaliitto ry 2004, 9).

Producing appropriate documents is important when designing electric systems. The documents that are required for the assembling and wiring of the machine must be delivered in an appropriate form such as drawings, diagrams, tables and instructions. These documents must be in agreed language. The documents of a simple machine can be included in one document requiring that the document shows all the components and makes it possible to do the wiring (SFS-EN 60204-1 2006, section 17).

Electric devices and apparatuses must be designed, built and manufactured in a way that they cause no threat to anyone's life, health or property (Sähköturvallisuuslaki 1996, section 2, 5§). Therefore safety must be taken into account, when designing an electric system.

Electric circuits are always drawn in the initial condition, so that all the components are in a dead state. For example NO switch is drawn with the contact open. The live wire shall be located on top of the circuit and the neutral on the bottom. To make the connecting, troubleshooting and changing of the components easier, DIN rail terminals are used. These terminals should be named for example as X1. Fuses shall be named for example as F1, relays as K1, buttons as S1 and motors as M1 (Keinänen, Kärkkäinen, Lähetkangas & Sumujärvi 2007, 79-90).

Conventionally in automation applications PLCs are used to control the systems' actuators by the information received from the sensors. With a PLC the machine or

process can be controlled accurately and safely (Keinänen, Kärkkäinen, Lähetkangas & Sumujärvi 2007, 7).

3 MACHINE DESCRIPTION

In the first project meetings, the overview of the construction and functions of the machine were determined. A picture of a similar machine (figure 3) was shown in the meeting to get an idea of what kind of a machine was planned to be built. The machine in the figure has a similar form factor and construction to the planned machine.

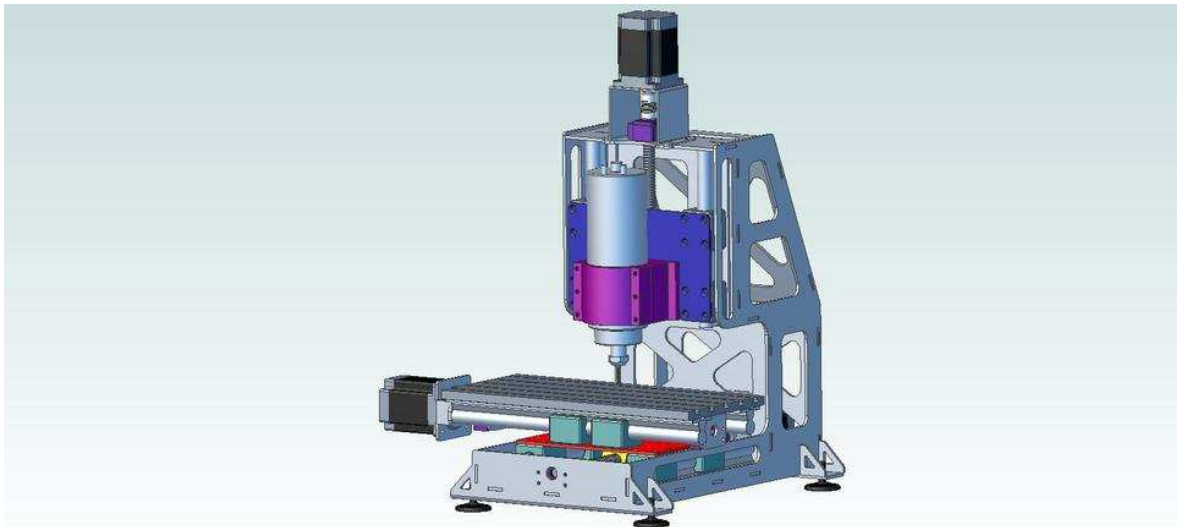

Figure 3. Small milling machine (GRABCAT, 2012)

The goal of the project is to make a small form-factor CNC milling machine, which should be portable enough to be carried by a person or two. The machine will have three linear servo driving mechanisms, each perpendicular to each other, to form X, Y and Z axes. The outer dimensions were estimated to be 500mm on each side and the motion lengths of 200mm-300mm for every axis. To prevent the movement from hitting the ends of the axes, two sensors are installed to each end. The movement of the X and Y axes are implemented by moving the table under the work piece and Z axis by lowering and rising the milling motor. The machine is going to be covered with a clear plastic cover to prevent the possible grit from flying around. This functions also as an additional safety feature. The machine is going to be separate from the enclosure that houses the electrical components and the PLC, and it must be detachable. The monitor, mouse and keyboard are connected to the PLC for monitoring and using the machine.

In the figure 4 there is a similar system. A work piece is attached to a table, which is moved in X and Y directions by two servo driving mechanisms. Blue switches for limiting the motion can also be seen in the figure. The construction for the X and Y axes will be similar and the Y axis, which will control the milling motor in relation to the table, is put perpendicularly to the table.

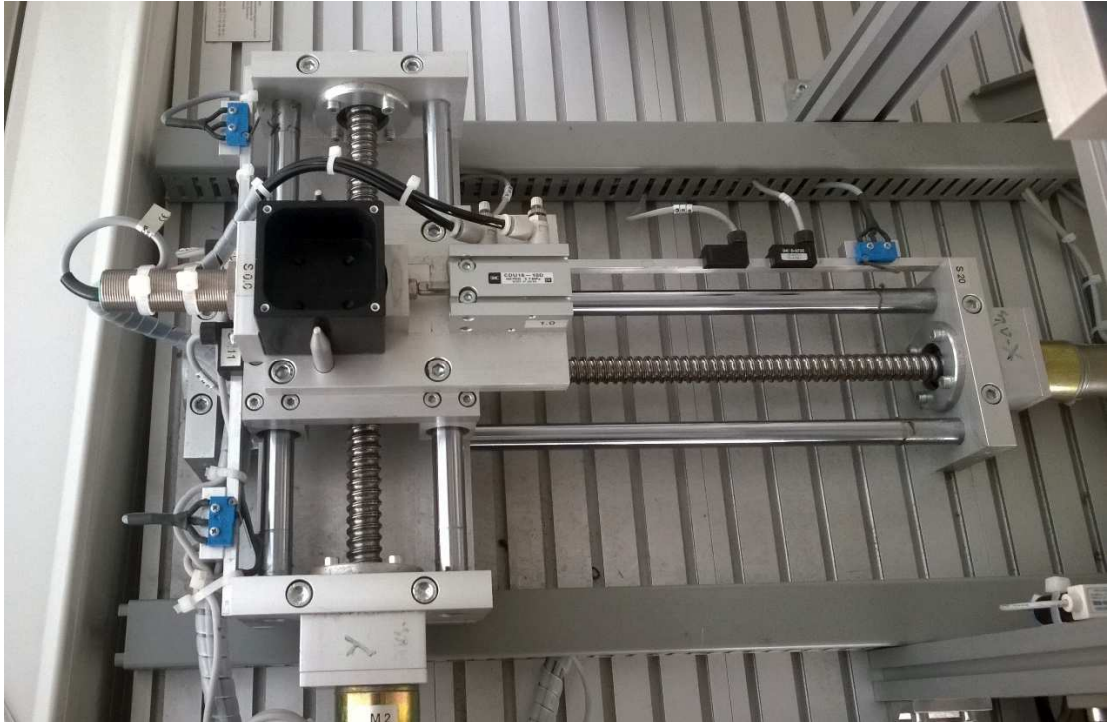

Figure 4. Table and work piece on two servo driving mechanisms

3.1 Functional description

The user takes the plastic cover off the machine and places a block of raw material on the bed, which is connected to the X- and Y-axes. The cover is placed on the machine and the user configures the machine and downloads a program to the PLC, for example, with a flash drive which contains data of a model that will be machined from the raw material. X- and Y-axes move the block and Z-axis moves the milling motor according to the model file. A milling motor spins a tool which mills the desired shape out of the block according to the program.

3.2 Safety

For designing the safety system for the machine guidelines from standard SFS-EN ISO 13849-1 were utilized. The standard covers the safety-related parts of the control systems for machines. The purpose of the following standard guidelines is to achieve safety objectives and to reduce risks. In the first place safety risks are removed and minimized by mechanical design, and furthermore by technical solutions and safety devices (Keinänen, Kärkkäinen, Lähetkangas & Sumujärvi 2007, 272-273).

3.2.1 Performance level (PL)

PL is described in the SFS-EN ISO 13849-1_(vi) standard as follows:

The ability of safety-related parts of control systems to perform a safety function under foreseeable conditions is allocated one of five levels, called performance levels (PL). These performance levels are defined in terms of probability of dangerous failure per hour.

To determine the performance level of the machine, SISTEMA (Safety Integrity Software Tool for the Evaluation of Machine Applications) (figure 5) software was used. It is used to make the safety planning and PL classification easier.

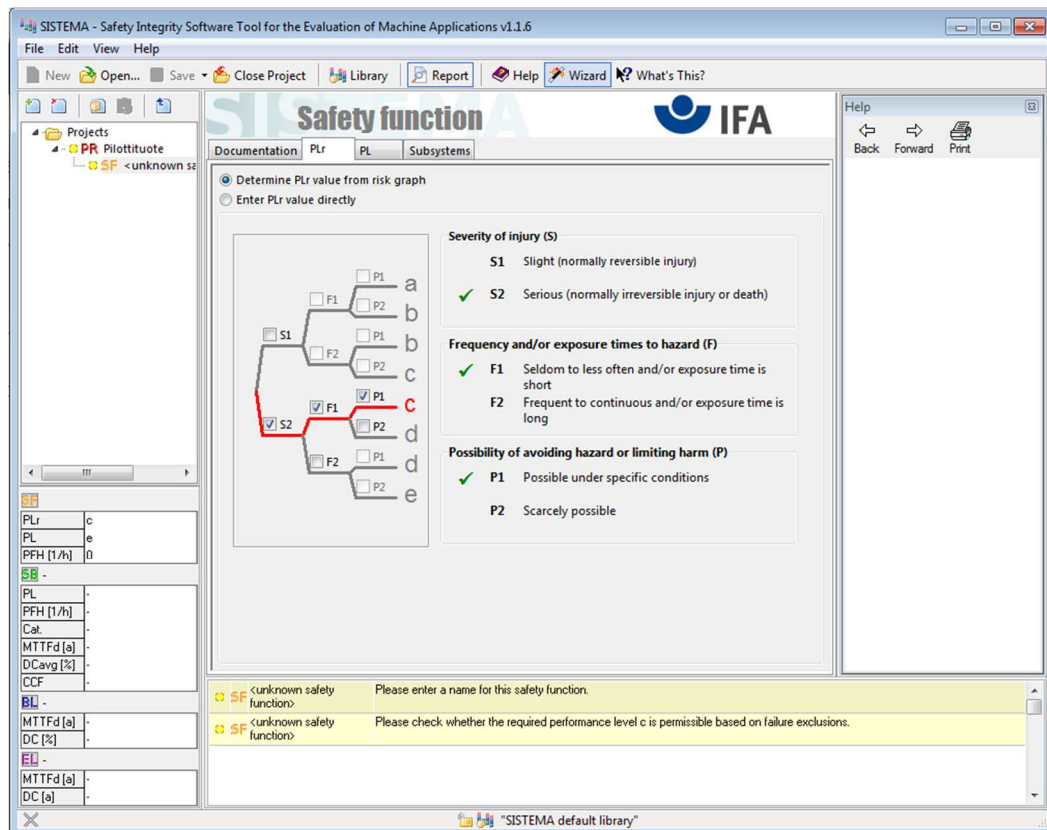

Figure 5. SISTEMA software

The determining of the required PL class (PLr) is made with a help of 3-stage diagram (figure 5). It starts with estimating the severity of injury. The milling motor spins a sharp tool with high speed, which can cause open wounds and bleeding, therefore the S2 option was selected. The second parameter is about frequency and/or exposure to a hazard. The user of the machine needs to be close to the machine only when the user attaches or removes the work piece from/to the machine. Therefore the user is not continuously exposed to a risk and thus option F1 was selected.

In the last parameter the possibility of avoiding the hazard is evaluated. The axes which move the table and milling motor have quite a low velocity and the movements of the axes are short. Therefore there is a realistic chance to avoid accidents or significantly reduce the effect and hence the P1 option was selected.

The required performance level (PLr) for the machine is c. With the determined level the right security components can be chosen (SFS-EN ISO 13849-1 2008, Annex

A). For the cutoff relays on the emergency circuit, it was decided to use a redundant system, in other words two relays in a series, to increase reliability.

3.2.2 Safety functions

The safety functions of the machine include a safety-related stop function and a manual reset function. These functions are controlled by a safety relay or a similar device. A safety-related stop function shall, as soon as necessary after actuation, put the machine in a safe state. After a stop command has been triggered, the safe state is maintained until safe conditions for restarting have been achieved (SFS-EN ISO 13849-1 2008, 5.2). This function is going to be implemented with safety inputs, such as emergency stop pushbutton, and relays which cuts off the power from motors to stop all motion. Stop category 0 will be used, which is defined in the SFS-EN 60204-1 (9.2.2) standard as follows: “stopping by immediate removal of power to the machine actuators.”

According to the SFS-EN ISO 13849-1 (5.2) standard the manual reset function should be a separate manual input for example a pushbutton, function only when all the faulty states have been cleared and enable the start of the machine when the input is disengaged from on position. The manual reset function is going to be implemented with a momentary pushbutton, one for each safety-related stop function triggering input.

3.3 I/O definition

The inputs and outputs were determined while planning the mechanical functions and safety features. All the inputs and outputs were listed to help determining what kinds of and how many components needed to be acquired.

Input list. A list of all the sensors and switches, which are used to sense the outer boundaries of the axes and to trigger and reset safety functions was compiled. It consists of the following inputs:

- X-axis lower limit

- X-axis upper limit
- Y-axis lower limit
- Y-axis upper limit
- Z-axis lower limit
- Z-axis upper limit
- error reset 1 –pushbutton
- error reset 2 –pushbutton
- emergency stop –pushbutton
- safety door switch.

Output list. The actuators and functions, which are controlled, are:

- error 1 –indicator light
- error 2 –indicator light
- milling motor
- servomotor X-axis
- servomotor Y-axis
- servomotor Z-axis
- milling motor off 1
- milling motor off 2
- servomotors off 1
- servomotors off 2.

4 HARDWARE

Some components that were needed for the machine were available from SeAMK's own stock and the rest were to be purchased from suppliers. In the beginning of the project it was decided to purchase all components possible from Beckhoff, since it is cooperation partner with SeAMK. Theirs product range covers Industrial PCs, I/O and Fieldbus Components, Drive Technology and automation software. The suppliers for the rest of the components was not decided. Therefore after gathering a rough list of the components that were needed for the machine, the price for the component list from several suppliers were compared. After finding the most suitable suppliers, the specific components were chosen (Appendix 4). This section doesn't cover all the individual components, rather provides an overview of the main components.

4.1 PLC

A programmable logic controller, or PLC, is to be used for controlling the milling machine. NC needs additional hardware if implemented with a traditional PLC, therefore an embedded PC or an industrial PC was a preferred choice for the system. These options also offer the possibility to use the machine with suitable MMI for the application for example monitor with mouse and keyboard.

Beckhoff CX5120 -embedded PC (figure 6) was chosen for the control of the machine. The CX-series Embedded PCs feature Beckhoff bus terminal system, which means that they are modular design that allows multiple I/O- and for example motion control-terminals to be connected. It has Intel Atom E3815- processor, which ensures short PLC cycle times and Windows Embedded Standard 7 P -operating system. The CX5120 has basic interface equipment, including Ethernet, several USBs and DVI-I (Beckhoff 2015, 10).



Figure 6. Beckhoff CX5120 - Embedded PC

The CX5120 is an embedded PC, which utilizes Soft-PLC to function as a traditional PLC. Soft-PLC is a programmable logic controller software, run on PC, which runs real-time logic program, in so called protected state. It ensures that the execution of the logic program doesn't depend on other programs on the PC or the state of the operating system (Keinänen, Kärkkäinen, Lähetkangas & Sumujärvi 2007, 213). Beckhoff software offers several solutions, such as interpolated motion control for several axes, to implement NCK functionality by the embedded PC (Beckhoff 2012, 10).

4.2 I/O

For all the inputs and outputs of the machine, several terminals were needed to be attached to the embedded PC. With the previously determined I/O list, suitable terminals were chosen to connect the actuators and sensors to the embedded PC.

4.2.1 Digital input and output terminals

There are total of eight digital inputs in the system, six for the limits of the axes and two for the error reset buttons. Beckhoff EL1004 was chosen for the system, shown as the leftmost terminal in figure 7. The terminal has four digital inputs (Beckhoff, 2014).

The system has total of six outputs, from witch three, milling motor and error indicator lights, are to be connected to digital output cards. Beckhoff EL2004 (2nd from the left in figure 7) was chosen for the system, since it has four digital outputs. It is suitable to control indicator lights and wide range of contactors and relays with nominal coil voltage of 24V DC (Beckhoff, 2014).

4.2.2 Safety Logic controller and Safety I/O terminals

Safety relays are devices, which function is to increase machine safety. They are used to prevent uncontrollable functions and thus decrease human and material damages (Keinänen, Kärkkäinen, Lähetkangas & Sumujärvi 2007, 54). A safety PLC was decided to be used in this application, instead of safety relay, for the safety inputs and outputs. Beckhoff EL6900 TwinSAFE PLC was chosen for the safety logic controller, it is shown in figure 7 as third terminal from left. It is designed to be connected to the Beckhoff Bus Terminal system, and therefore several input and output terminals can be connected to it. The EL6900 features certified safety function blocks for logic control, which are to be used to program the functionality instead of hard wiring them. (Beckhoff, 2015)

The system has 2 safety inputs, an emergency stop button and a safety-door switch. Beckhoff EL1904 is a digital input card with four fail-safe inputs. For the four safety outputs (milling- and servomotor cutoffs), the Beckhoff EL2904 digital input terminal was chosen. It has four outputs with maximum output current of 0,5A per channel. The terminals are shown in the figure 7. EL2904 is the double sized terminal on the right and EL1904 next to it on the left (Beckhoff, 2014).

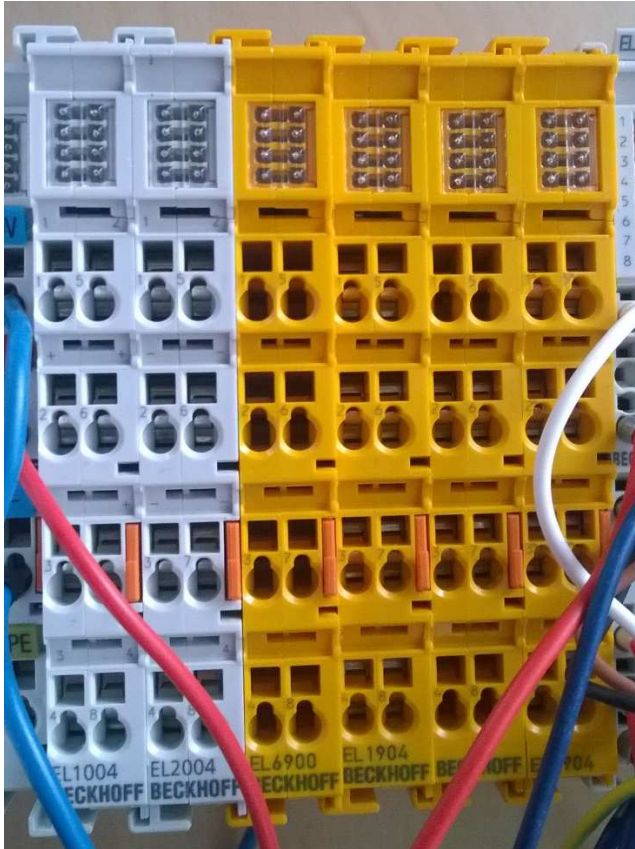

Figure 7. I/O terminals and Safety PLC EL6900

When determining the required performance level of the machine, the required performance level (PLr) was found to be c. Both safety terminals and the Safety PLC are suitable for applications up to SIL 3 according to IEC 61508 and up to PL e according to DIN EN ISO 13849. Since the PL of the terminals and Safety PLC are higher than the PLr rating, they are suitable for the machine.

4.2.3 Motors and motor drives

In a NC machine, electric motors are used to precisely move every independent axle. It is required to stop precisely and unconditionally to the programmed position. Defined movements must be carried out within programmed speed. Acceleration to the set speed and deceleration on the end of the motion must be executed in small time period. Therefore, dynamic properties are the most important features for motors in such systems. The three most common motor types in NC machines are:

1. stepper motors, fully electric or equipped with a hydraulic torque converter

2. direct current motors, mostly brushless motors
3. three-phase motors, mostly asynchronous motors.

(Opetushallitus, 2010)

Two types of motors were considered for the machine axes, stepper motor and servomotor. The advantages of the stepper motor were compact size and affordable price of the system. Eventually it was decided that the servomotor is more suitable for the application. Servomotors have higher dynamic properties, which is the most important property, and are equipped with rotary encoder (Suk-Hwan, Seong-Kyoon, Dae-Hyuk & Stroud 2008, 9).

Beckhoff AM8100-series servomotors, coupled with servo drives were chosen for the machine due to the compact size, ease of installation and since the torque is sufficient for the machine. The motor is brushless and synchronous three-phase servomotor Beckhoff AM8131 (figure 8). It has rated torque of 1,25Nm and rated speed of 1000rpm. It has absolute encoder with accuracy of 120 angles per second and resolution of approx. 0.03 degrees. There was several versions of this motors, with different type of connections and encoders. The model that was chosen has absolute encoder and single cable connection for the encoder and the power input. The absolute encoder was preferred, because it eliminates the need to do a reference run, and therefore makes the program of the machine simpler (Beckhoff, 2014).



Figure 8. Beckhoff 8131 servo motor

The manufacturer offers servo drives that are designed to be coupled with the AM8100-series motors and are Beckhoff bus terminal compatible. The Beckhoff EL7211-0010 -servo terminals (figure 9) were the chosen, since it can utilize the full power of the chosen servomotor. It also has two digital inputs and One Cable Technology or OCT, which allows the motor to be connected with one cable, instead of using separate cables for powering the motor and for the encoder. It is compact in size, has rated power of 276W and is supports fast and highly dynamic positioning tasks. The Terminal has separate power inputs for the terminal and for the servomotor. Nominal voltage for the servomotor input is 8V – 50V. The used voltage affects the maximum speed of the motor. For example with 24V the maximum speed is 200rpm for the chosen motor and with 48V it is the full speed of the motor, 1000rpm (Beckhoff, 2014).

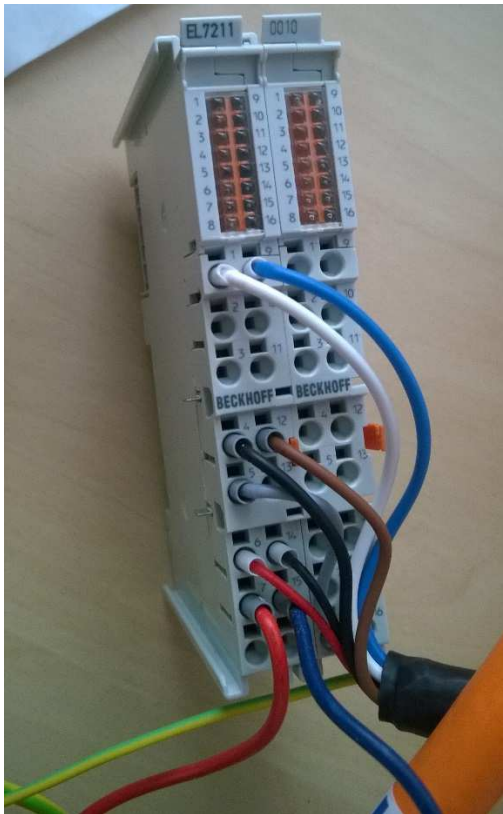

Figure 9. Beckhoff EL7211-0010

For the milling motor it was decided to use a power tool attached to the machine, instead of spindle motor, since it is less expensive option compared to high-speed spindle motors. Kress 1050 FME-1 was the chosen milling motor. Nominal rated input of the motor is 1050W, voltage of 230VAC and speed from 5000rpm to 25000rpm. It can be mounted to the machine from its metal clamping collar. Assortment of different cutting bits and a collet was chosen to go with the milling motor (Kress).

In the figure 10 the Embedded PC CX5210 connected to all the terminals can be seen. There is also all the motors connected to the servo terminals with the OCT system. The motors were connected temporarily to the system for testing purposes.

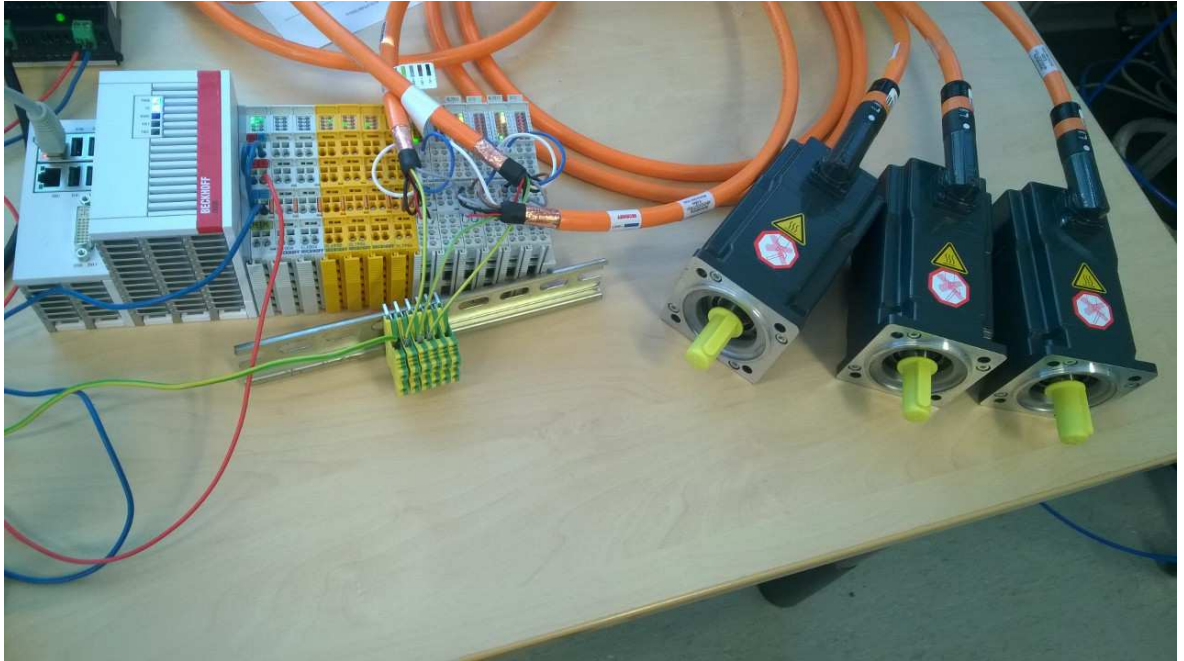

Figure 10 The embedded PC with all the terminals and servo motors.

4.2.4 Inputs

To limit the motion of the axes by sensing when the table is near the end boundaries of the axes, different limit switches and proximity sensors were compared. It was decided to use inductive proximity switches, since the construction of the machine is made of metal. Advantage of such switch is that it doesn't require a physical contact and therefore the lifetime is practically limitless and they are not vulnerable to vibrations (Keinänen, Kärkkäinen, Lähetkangas & Sumujärvi 2007). Small size and ease of installation were the main criteria for the sensor. The SICK IME08-04NPOZW2K was chosen for the sensor. It is M8-thread bodied inductive proximity

switch with normally closed contact. Thread bodied sensors are easy to install and can be adjusted by the thread as seen in figure 11.

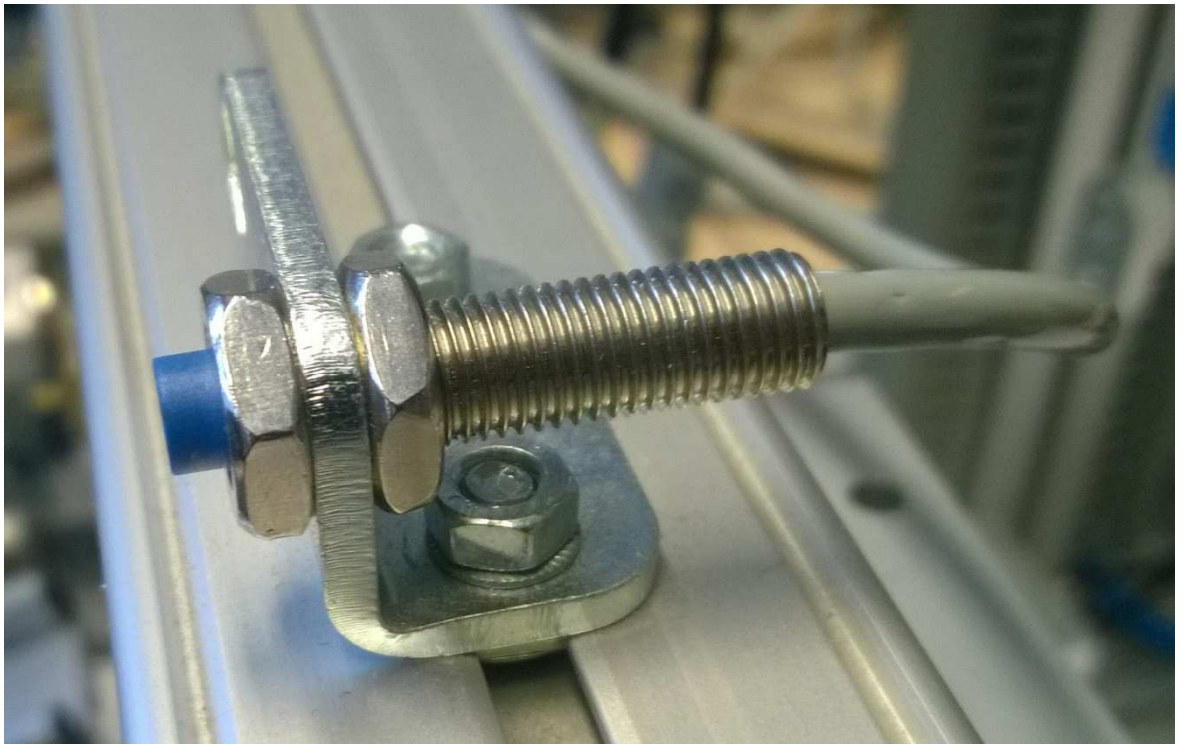

Figure 11 Mounting example of cylindrical inductive proximity switch

A safety-door switch is used to detect if the cover is in place. Some models have a locking function, but it was not needed in this case. OMRON D4NS-4BF was chosen since it has no locking feature and as it has two NC contacts. The switch is to be mounted to the base of the machine and a special operational key will be fixed to the cover, to open the contacts of the switch when the cover is inserted on top of the machine.

An emergency stop pushbutton was available from the SeAMK's stock. The button used is a big red button, which locks in when pressed and can be reset to the normal position by twisting. It is panel mount styled button and is going to be mounted on the cover of the electronic components enclosure. The button is used with NC contacts.

Error reset pushbuttons were also available from SeAMK's stock. The button is a momentary pushbutton with NO contacts and an indicator light. Two of these buttons

are also going to be mounted on the cover. One is used for resetting the error state caused by the emergency stop button and another for the safety-door switch.

4.2.5 Outputs

To stop the motion of the axes and spinning of the spindle on the milling motor, relays are to be used to cut the power input of the motors. There were few different kinds of relays in SeAMK stock and the type chosen was relay with single NC/NO contact. It is rated for up to 230V AC or 125V DC voltage and 5A current. Four of these are used in safety circuit. Turning the milling motor on and off is also controlled with relay. Same type of relay was chosen for this application.

To indicate when the machine is in error state, the indicator lights in the error reset buttons were used. One is used to indicate the error state caused by the emergency stop button and other for the safety-door switch.

4.3 Power supplies

When all the electronic components were chosen, the maximum currents used by the components were calculated. Suitable power supplies were chosen according to the calculations. The system uses mainly 24V DC, but the servo motor drives require 48V DC to achieve the full speed with the motors. Therefore two different power supplies were selected for the system. For powering the servomotors Mean Well SDR-960-48 was chosen. It produces up to 20A of current with voltage of 48V. For the rest of the system Mean Well SDR-120-24 was chosen. It is rated for 5A with 24V.

4.4 Enclosure

When all the components that are going to be mounted in an enclosure were selected, it was possible to choose suitable one. Some components had

requirements for the enclosure, such as minimum IP-classification and maximum temperature, so the enclosure was chosen to meet the requirements of the components. The Safety PLC had the strictest requirements: temperature 0 °C to +55 °C and minimum protection class of IP54. Other criteria for choosing the enclosure were compact size and light weight. Transparent cover was preferred, so the components inside can be seen.

After modeling the layout drawing (Appendix 2) of the internal components, suitable enclosure was chosen, Fibox PC 563818T. The enclosure is made of polycarbonate and it has see-through cover. Dimensions are 378mm x 588mm x 180mm and it has IP-certification of IP66.

Since the enclosure is dust tight and it is protected against powerful water jets (IP66) and has no ventilation, it was assumed that the temperatures may rise above the maximum rating of the components, so it was decided to add ventilation parts. Two IP54 certified ventilation filters and one industrial fan were chosen to get rid of the heat.

4.5 Connectors

The machine was designed to be portable, so to make it easier and faster to relocate and operate, connectors are used. All the cables that go from the enclosure to the machine were needed to be detachable by connectors on the side of the enclosure. The servomotors have detachable connectors on the end of the servo motors and will be detached from those connectors, instead of using separate connectors on the enclosure. Two connectors were chosen, one for the milling motor and other for the safety-door switch and sensors. For the milling motor, Harting Han kit 3A industrial connector was chosen. It was decided to use proprietary connector instead of regular 230V socket and plug connection, because there is relay control in the circuit, so it's not possible to plug in other electric appliances. For the rest of the cables Harting Han-kit 10A industrial connector was used which has total of 13 contacts. It was decided to use separate connectors for the milling motor and sensors since they have different voltages. Both of the connectors have IP65 certification.

To connect input devices (e.g. mouse, keyboard) and to access Ethernet and video port of the embedded PC, connectors were chosen. It was decided to add panel mounted connectors on the cover and connect them to embedded PC in the enclosure. For these Aspenol solder trail IP67-certified connectors were selected. One connector for Ethernet port, three USB connectors and HDMI connector, which is going to be soldered to cable with DVI connector to connect it to the embedded PC.

5 CIRCUIT AND LAYOUT PLANNING

The circuit diagrams are divided into different sheets such as the main circuit, a voltage allocation, a safety circuit, in- and output circuits. Additional sheets that make it more understandable and help the electrician to wire and assemble the machine can also be included in the documentation. The layout model should show all the placements for the components and make it easy to install.

The circuit diagrams and a layout model were designed using CADS Planner 13. It is CAD software and has different toolsets for layout and electric drawings. The machine will be wired and assembled according to the drawings. In the figure 12, the drawing style can be seen. Green wire is 230V DC live wire and red can be neutral, ground or lower DC wire. Yellow wires are cables. Connectors for the power input and the Han Kit connector can be seen on the left and at the bottom. Also a fuse F1, contacts from relays K1-K3 and two power supplies shown. Dots named as X1 and so on represent DIN rail connection terminals, but they are not shown in figure 12.

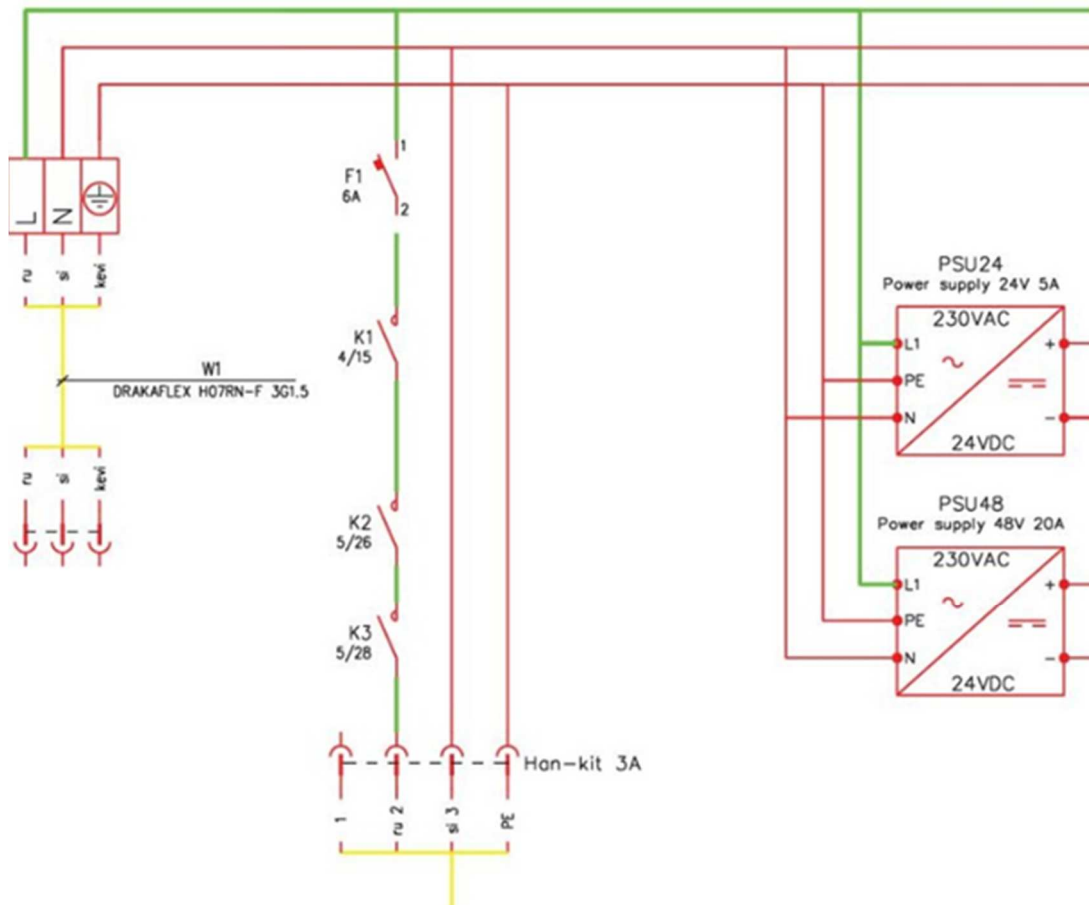

Figure 12 Circuit diagram drawing example

5.1 Circuit planning

In the main circuit (Appendix 1, sheet 1) there is the power input of the machine. It is powered from a standard 230V AC socket. There is also a fuse for the milling motor. The size of the fuse was calculated for the circuit. The milling motor and the power supplies connected to the AC voltage, can be seen in the appendix too. The voltage allocation sheet (Appendix 1, sheet 2) shows how the different voltages from the power supplies are distributed and the fuses calculated to protect the components from overcurrent.

The next three sheets (Appendix 1, sheets 3-5) show how the inputs and outputs are connected from the different input and output terminals to the sensors, switches, relays and indicator lights. On sheet three there is the embedded PC, the input terminal, connector for the inputs, joint box marked as position +JR1 and the system

fan. On the next sheet there is the output terminal and the indicator lights for errors as well as the relay coil, which controls the milling motor. On the fifth sheet there is the safety PLC and its input and output terminals. Safety-door switch and emergency pushbutton are connected to the input. The relays that cut off the power from the servo motors and the milling motor are connected to the output. The servo drives sheet (Appendix 1, sheet 6) shows the wiring of the servo drives and servomotors.

Wiring sheet (Appendix 1, sheet 7) was drawn to help an electrician to do the wiring. It shows on one sheet a set of connections which were previously spread on several sheets. In the last sheet (Appendix 1, sheet 8) the used components are listed with the abbreviations used in the drawings and the model names of the components.

5.2 Layout planning

Layout drawing (Appendix 2) was made to determine the size of the enclosure and to show the placements of the components. First all the components that are placed inside the enclosure were drawn and different arrangements tried. This gave the approximate size required for the enclosure. After the enclosure was chosen its dimensions were drawn and all the component drawings placed inside with appropriate spacing. Some components had requirements such as installation orientation and free space around the component. Another drawing was made of the face of the enclosure. All the connectors and buttons were placed to the drawing.

6 CONCLUSIONS

The goal of this thesis was to design an electric system for a CNC-machine and to produce an appropriate layout and electric diagrams. An objective was also to find solutions for the machine's functionality, choose all the components for the system and to find a supplier to provide the mentioned components. There were some regulations and safety concerns to be taken into account while designing and finding the components.

As a result, the solutions for implementing the functionality and the right components and suppliers were found. The list of components was approved in project meetings and the orders were placed for manufacturing the machine later. The layout and circuit diagrams were produced, which will be used to wire and assemble the system and they will be added to the documentation of the machine. The machine will be built later in the year 2015.

The process of designing an electronic system for the machine starting from the basic ideas about the functionality was really educating and interesting. And being a part of a bigger project offered new experiences on project work. A good motivator was that the machine will be manufactured based on the designs. I learned a lot about electric designing and got to know some of the regulations and standards.

BIBLIOGRAPHY

- Beckhoff. (2012, 4). *TwinCAT 3 – eXtended Automation Technology (XAT)*. Retrieved from http://download.beckhoff.com/download/document/catalog/Beckhoff_TwinCAT3_042012_e.pdf
- Beckhoff. (2014, 12 17). *Documentation Synchronous servomotor AM8100*. Retrieved from http://download.beckhoff.com/download/Document/Drives/AM8100_BA_en.pdf
- Beckhoff. (2014). *EL1004 | 4-channel digital input terminal*. Retrieved 1 10, 2015, from <http://www.beckhoff.com/english.asp?ethercat/el1004.htm>
- Beckhoff. (2014). *EL1004 | 4-channel digital input terminal* . Retrieved 1 10, 2015, from http://www.beckhoff.com/english.asp?embedded_pc/cx5100.htm
- Beckhoff. (2014). *EL1904 | 4-Channel digital input terminal*. Retrieved 1 10, 2015, from <http://www.beckhoff.com/el1904/>
- Beckhoff. (2014). *EL2004 | 4-channel digital output terminal*. Retrieved 1 10, 2015, from http://www.beckhoff.com/english.asp?embedded_pc/cx5100.htm
- Beckhoff. (2014). *EL2904 | 4-channel digital output terminal*. Retrieved 1 10, 2015, from <http://www.beckhoff.com/el2904/>
- Beckhoff. (2014, 11 04). *EL7201-0000*. Retrieved from Beckhoff Corporation Website: <http://download.beckhoff.com/download/Document/BusTermi/BusTermi/EL72x1-0010en.chm>
- Beckhoff. (2014). *EL7211-0010 | Servomotor terminal with OCT*. Retrieved 1 10, 2015, from <http://www.beckhoff.com/el7211-0010/>
- Beckhoff. (2014, 12 17). *Synchronous servomotor AM8100*. Retrieved from Beckhoff Corporation Web Site: http://download.beckhoff.com/download/Document/Drives/AM8100_BA_en.pdf
- Beckhoff. (2015, 1 5). *Hardware manual CX51x0*. Retrieved from http://download.beckhoff.com/download/Document/EPC/CX5100_HWen.pdf
- Beckhoff. (2015, 03 11). *Operating instructions for EL6900*. Retrieved from <http://download.beckhoff.com/download/Document/TwinSAFE/EL6900en.pdf>
- Bolton, W. (2006). *Programmable Logic Controllers*. Oxford: Elsevier Newnes.

Bolton, W. (2008). *Mechatronics a Multidisciplinary Approach*. England: Pearson Education .

GRABCAT. (2012). *GRABCAT*. Retrieved 1 10, 2015, from <https://grabcad.com/library/mini-cnc>

Keinänen, T., Kärkkäinen, P., Lähetkangas, M., & Sumujärvi, M. (2007). *Automaatiojärjestelmien logiikat ja ohjaustekniikat*. Helsinki: WSOY Oppimateriaalit.

Kress. (n.d.). *1050 FME-1*. Retrieved 1 10, 2015, from [http://www.kress-elektrik.com/Power-tools.71.123.html?&no_cache=1&L=1&tx_commerce_pi1\[catUid\]=17&tx_commerce_pi1\[showUid\]=1035](http://www.kress-elektrik.com/Power-tools.71.123.html?&no_cache=1&L=1&tx_commerce_pi1[catUid]=17&tx_commerce_pi1[showUid]=1035)

Neuvottelevat Sähkösuunnittelijat NSS ry, & Suomen Sähkö- ja teleurakoitsijaliitto ry. (2004). *Sähkösuunnittelun Käsikirja*. Espoo: Sähköinfo Oy.

Opetushallitus. (2010). *Numeerisesti Ohjatut Työstökoneet*. Tampere: Opetushallitus.

SFS 6000-1. (2012). *Sähköasennukset Osa 1*. Helsinki: Finnish Standards Association SFS.

SFS-EN 60204-1. (2006). *Koneturvallisuus. Koneiden sähkölaitteisto. Osa 1*. Helsinki: Finnish Standard Association SFS.

SFS-EN ISO 13849-1. (2008). *Safety of machinery – Safety-related parts of control systems – Part 1*. Helsinki: Finnish Standard Association SFS.

Suk-Hwan, S., Seong-Kyoon, K., Dae-Hyuk, C., & Ian, S. (2008). *Theory and Design of CNC Systems*. Springer-Verlag London.

Sätköturvallisuuslaki. (1996). *410/1996*. Finlex.

APPENDICES

Appendix 1. Circuit diagram

Appendix 2. Layout drawings

Appendix 3. PL definition report

Appendix 4. Order list (excluding Beckhoff)

APPENDIX 1 Circuit diagrams

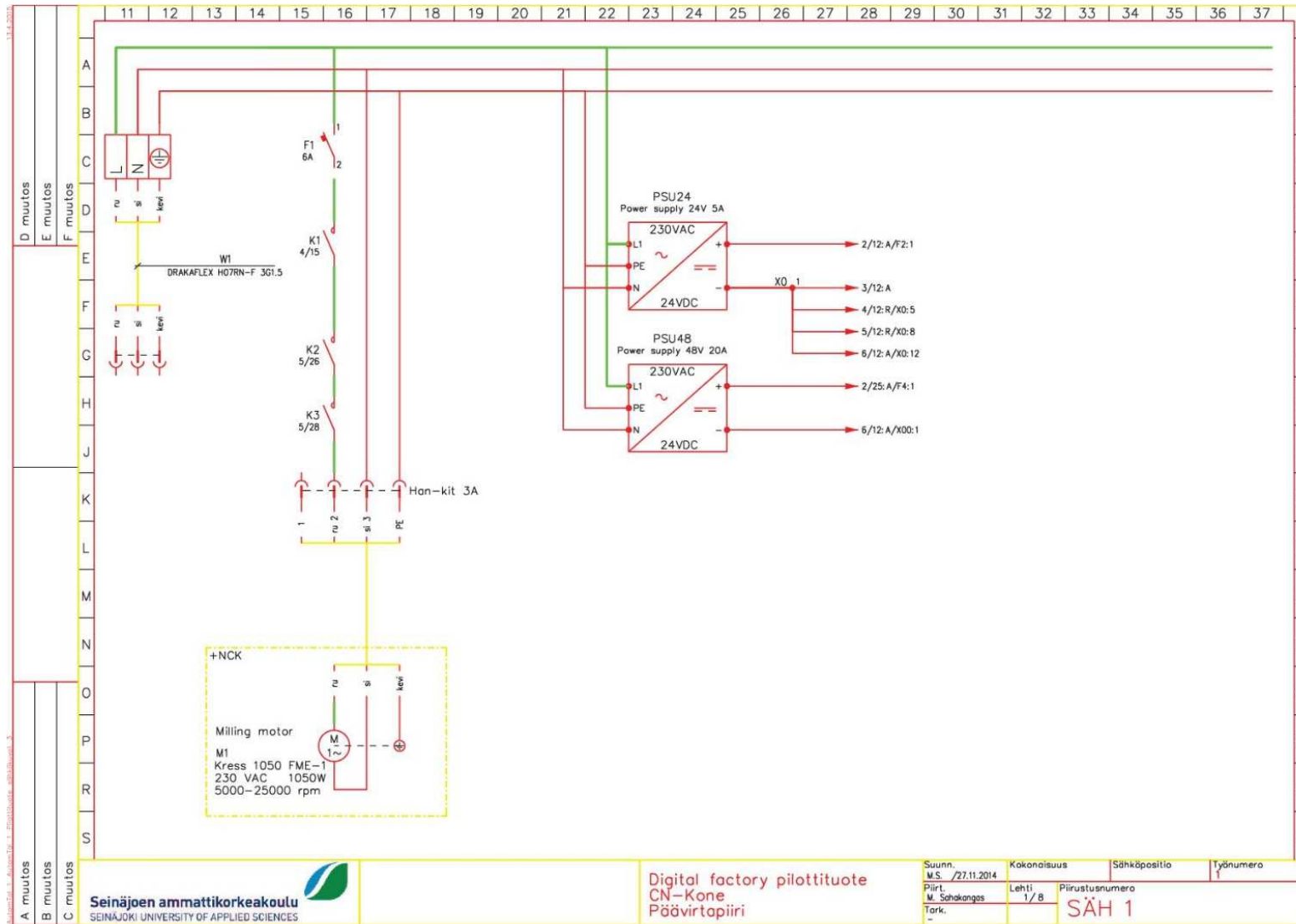

APPENDIX 1 Circuit diagrams

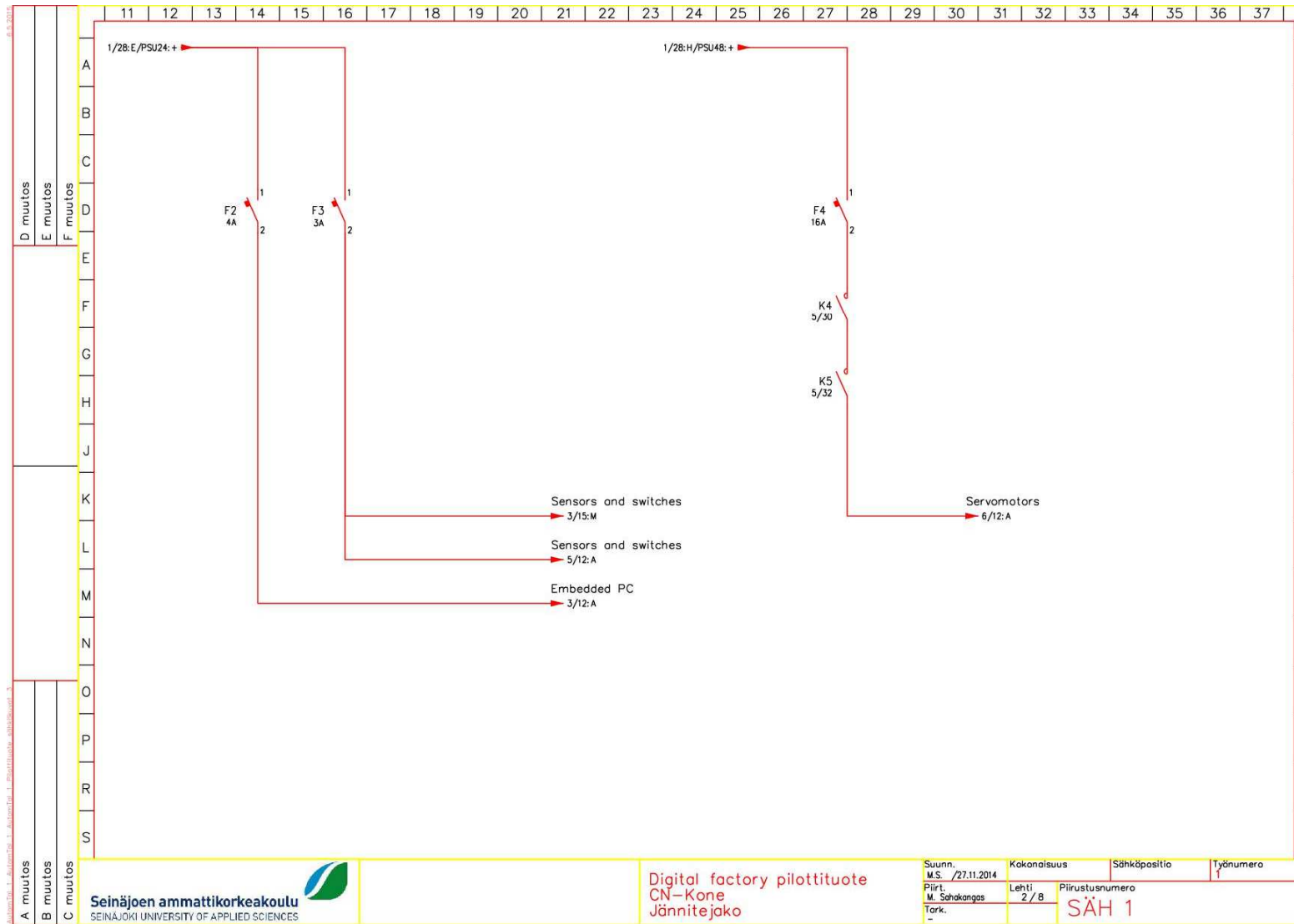

APPENDIX 1 Circuit diagrams

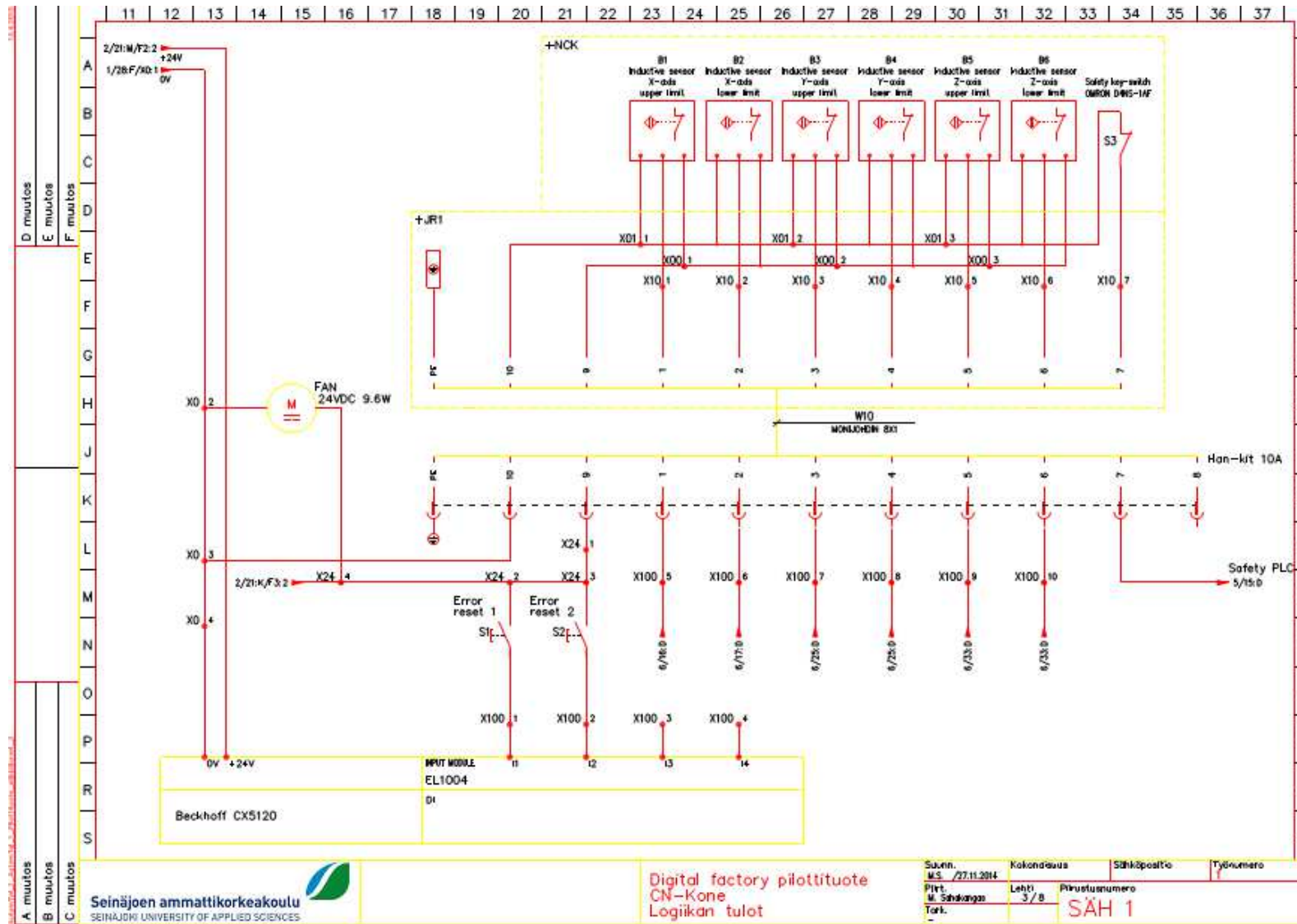

APPENDIX 1 Circuit diagrams

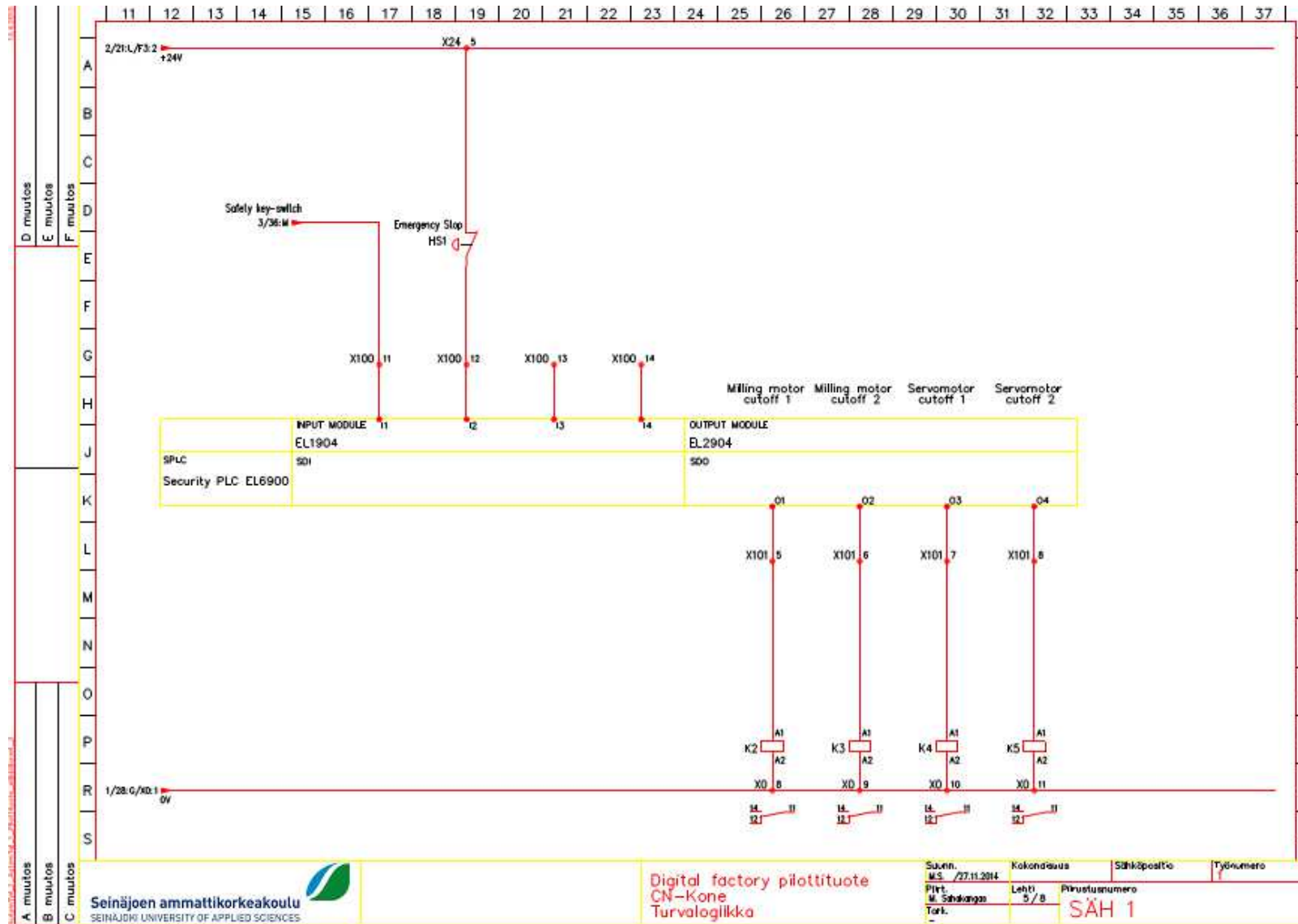

APPENDIX 1 Circuit diagrams

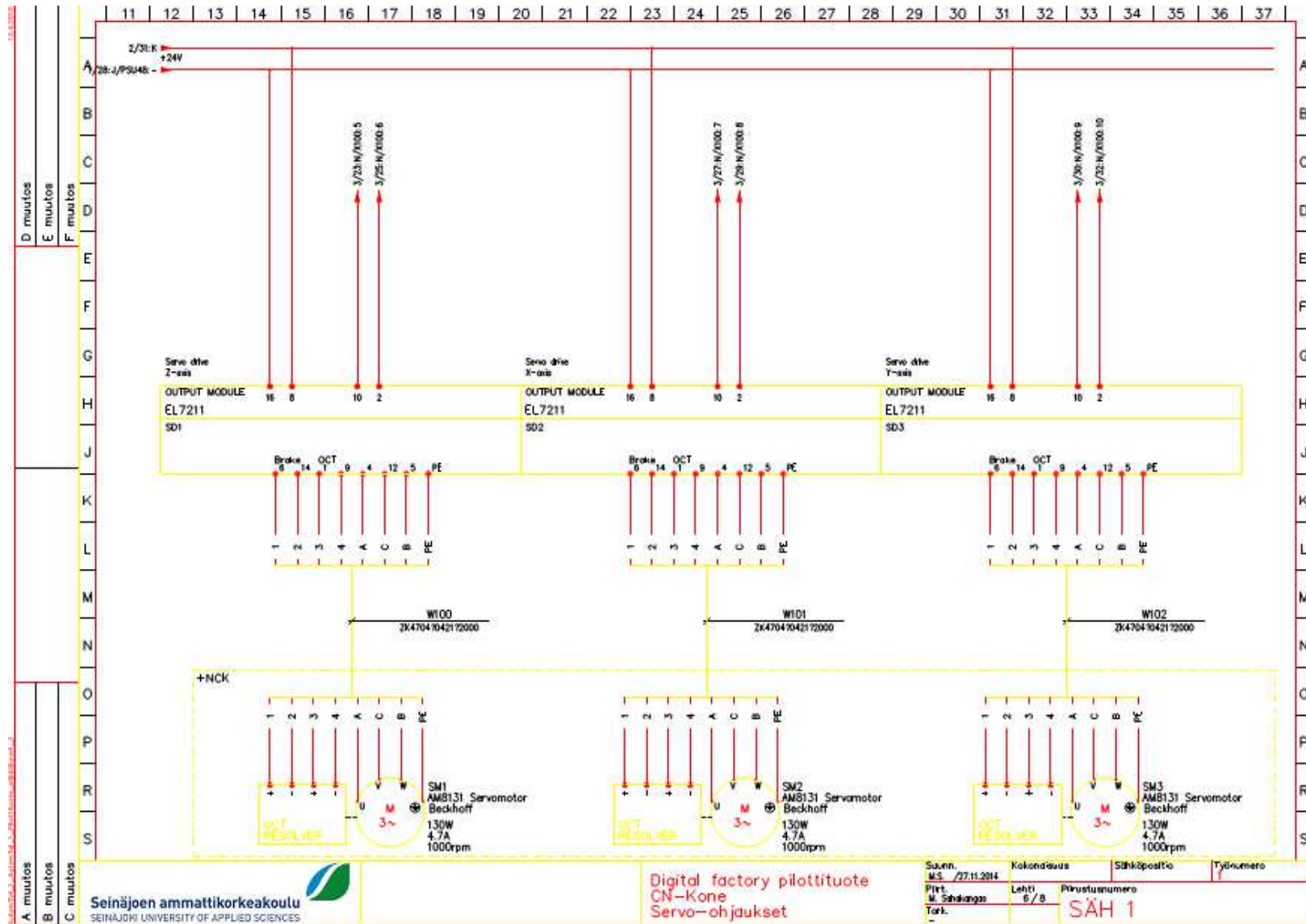

APPENDIX 1 Circuit diagrams

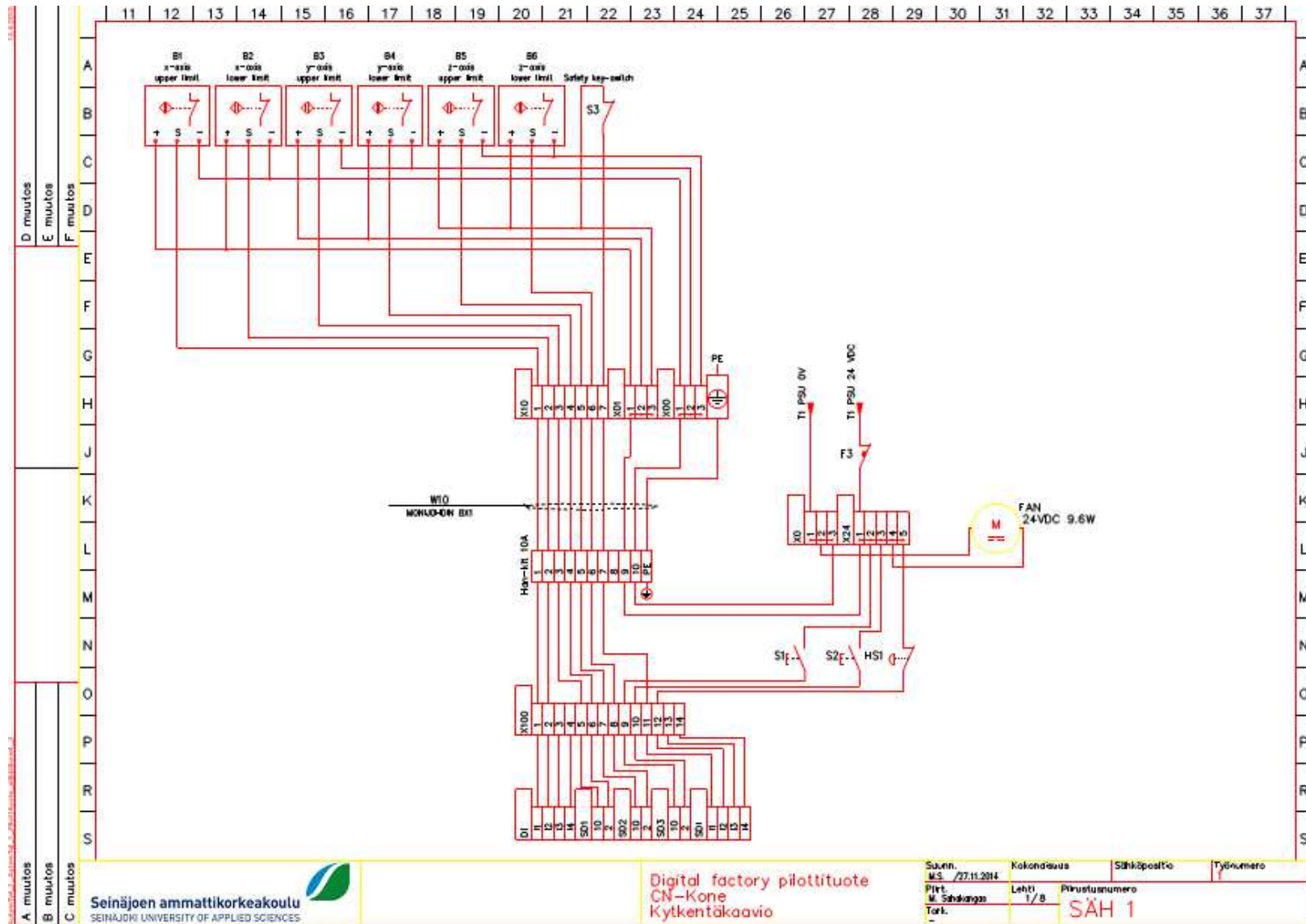

Sheet 7
Wiring diagram

APPENDIX 1 Circuit diagrams

		LAITE	TYYPPI	VALMISTAJA	MÄÄRÄ	NIMIKE	ALI- HANKINTA	HUOM.
D E F	1	Embedded PC / SoftPLC	CX5120-0120	Beckhoff	1	CX5120		
	2	Digital input-card	EL1004	Beckhoff	1	DI		
	3	Digital output-card	EL2004	Beckhoff	1	DO		
	4	Safety PLC	EL6900 TwinSAFE PLC	Beckhoff	1	SPLC		
	5	Safety digital input-card	EL1904	Beckhoff	1	SDI		
	6	Safety digital output-card	EL2904	Beckhoff	1	SDO		
	7	Servo drive-card	EL7211	Beckhoff	3	SD1, SD2, SD3		
	8	Servomotor	AM8131	Beckhoff	3	SM1, SM2, SM3		
	9	Inductive proximity sensor	IME08-04NPOZW2K	Sick	6	B1 - B6		
	10	Power supply 20A 48VDC	SDR-960-48	Mean Well	1	PSU48		
	11	Power supply 5A 24VDC	SDR-120-24	Mean Well	1	PSU24		
	12	Industrial connector set 10+PE	Han-kit 10A	Harting	1	Han-kit 10A		
	13	Industrial connector 3+PE	Han-kit 3A	Harting	1	Han-kit 3A		
	14	Relay	10A NO/NC	Omron	5	K1 - K5		
	15	Circuit breaker	3A	ABB	2	F2, F3		
	16	Circuit breaker	6A	ABB	1	F1		
	17	Circuit breaker	16A	ABB	1	F4		
	18	Safety key switch	D4NS-4BF	Omron	1	S3		
	19	Milling motor	1050 FME-1	Kress	1	M1		
	20	Push button	tba	tba	2	S1, S2		
	21	Indicator light	tba	tba	2	H1, H2		
	22	Enclosure cooling fan	EEC0382B1-000U-A99	Sunon	1	FAN1		
	23							
	24							
A B C	25							
	26							
	27							
	28							
	29							
	30							
	31							
	32							
	33							
	34							
	35							

APPENDIX 2 Layout drawing

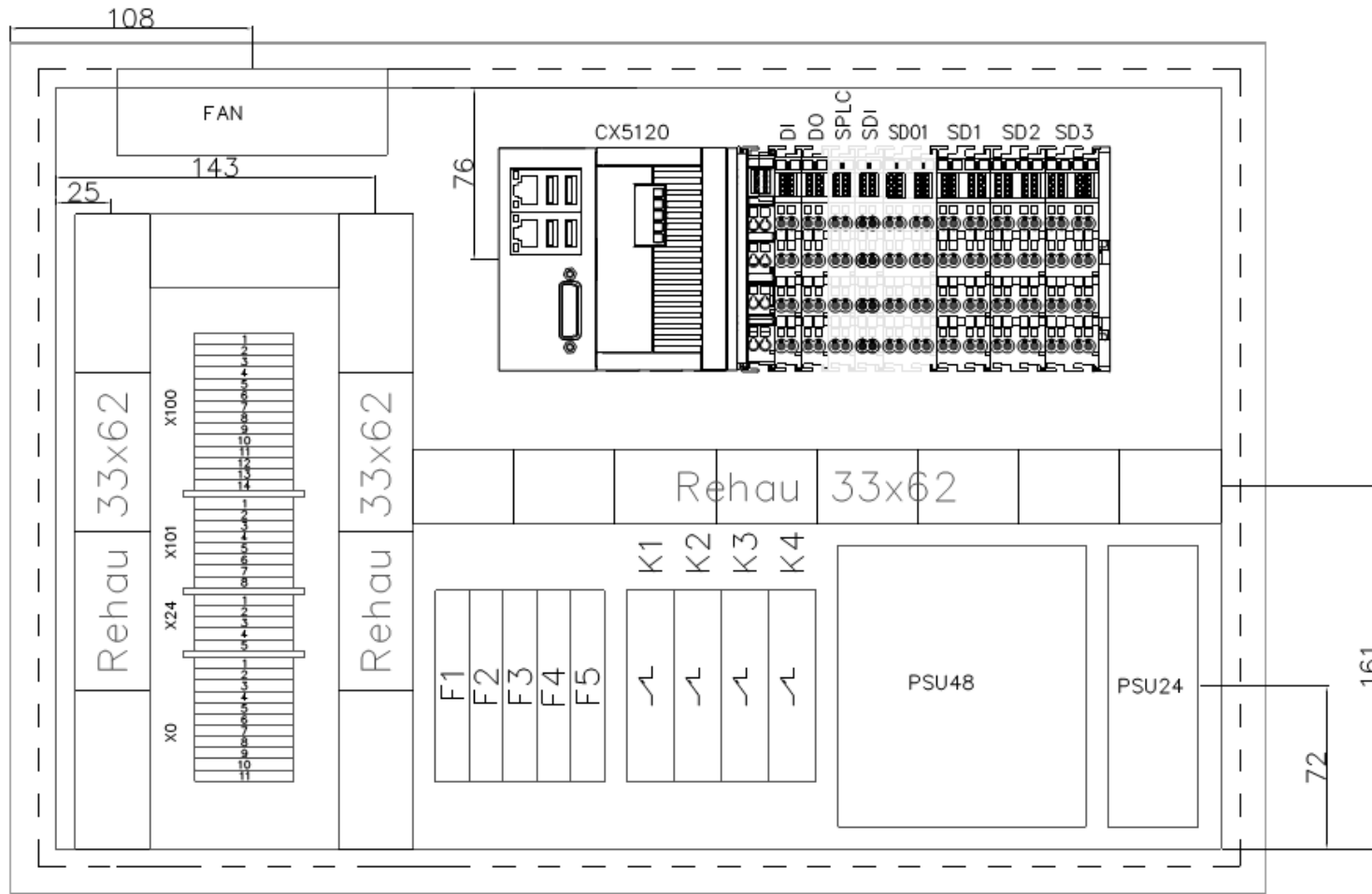

Sheet 1
Layout drawing of insides

APPENDIX 2 Layout drawing

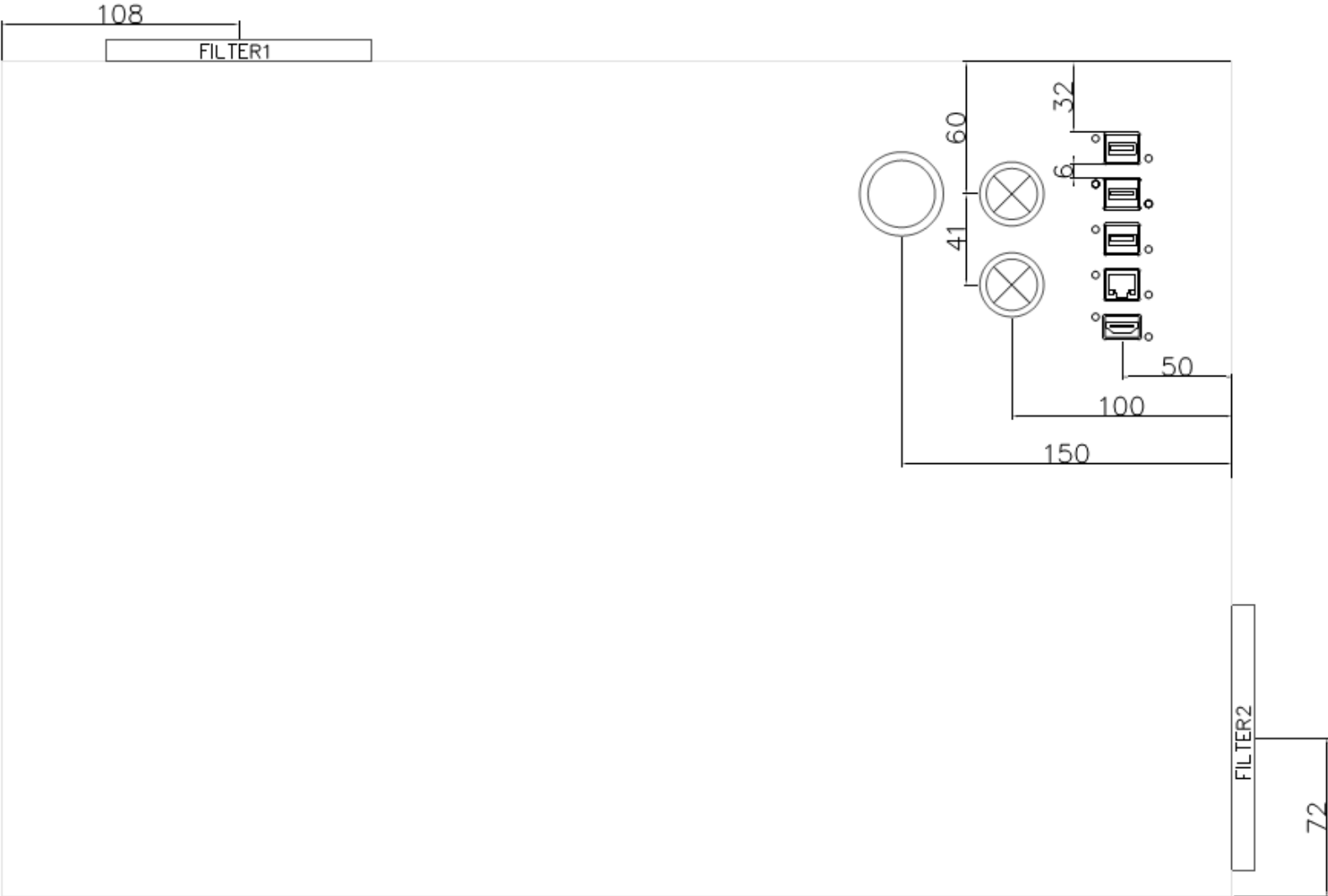

APPENDIX 3 PL definition report

SISTEMA - Ohjelmistotyökalu konesovellusten turvallisuuden eheyden arviointiin

Projektin nimi: Electrical interlocking of a movable guard - Category 3 - PL d

Tiedoston päiväys: 25.11.2014 Raportin päiväys: 25.11.2014 Tarkistussumma: ad02f5e4b4cf6f2a2d86400567d19960

PR Projektin nimi: Electrical interlocking of a movable guard - Category 3 - PL d

Tekijä:	IFA
Vaarallinen kohta/kone:	-
Dokumentaatio:	This example of a control circuit is based on example B from Annex I of EN ISO 13849-1: Safety of machinery - Safety-related parts of control systems. Part 1: General principles for design (11.06). with updates e.g. for the estimation of MTTFd and CCF.
Dokumentti:	
Tiedoston nimi:	C:\Users\k1100725\Documents\SISTEMA\Projects\en\pld_cat3_interlocking_of_movable_guard\PLd_Cat3_Interlocking_of_Movable_Guard.ssm
Ohjelmiston versio:	1.1.6
Standardin versio:	ISO 13849-1:2006, ISO 13849-1/Cor1:2009, EN ISO 13849-1:2006, EN ISO 13849-1:2008
Tarkistussumma:	ad02f5e4b4cf6f2a2d86400567d19960
Asetukset:	<input checked="" type="checkbox"/> Käytä DC:n väliarvoja PFH:n laskentaan (tarkempi). <input type="checkbox"/> Nosta MTTFd-arvon yläraja 100 vuodesta 2500 vuoteen luokassa 4
Tila:	vihreä
Huomautus:	Tähän projektiin (tai siihen kuuluviin peruselementteihin) ei ole merkitty yhtään varoitusta.

Tähän kuuluvat turvatoiminnot**SF** Nimi: Safety-related stop function initiated by safeguard

Vaadittu: PLr c

Saavutettu: PL d

PFH [1/h]: 1,86E-7

Tila: vihreä

APPENDIX 3 PL definition report

SISTEMA - Ohjelmistotyökalu konesovellusten turvallisuuden eheyden arviointiin  IFA
Institut für Arbeitsschutz der
Deutschen Gesetzlichen Unfallversicherung

Projektin nimi: Electrical interlocking of a movable guard - Category 3 - PL d

Tiedoston päiväys: 25.11.2014 Raportin päiväys: 25.11.2014 Tarkistussumma: ad02f5e4b4cf6f2a2d86400567d19960

VASTUUVAPAUCLAUSEKE

Ohjelmiston tuotannossa on huolehdittu, että se on tehty nykytekniikan tason mukaisesti. Ohjelmisto on tarkoitettu käyttöönotettavaksi korvauksetta.

Ohjelmiston käyttö tapahtuu käyttäjän omalla riskillä. Lainsäädännön antamissa rajoissa ei hyväksytä mitään lakiin perustuvaa vastuuta ohjelmistosta. Erityisesti mitään vastuuta ei hyväksytä aineellisista tai oikeudellisista virheistä, joko ohjelmistossa tai siihen liittyvässä dokumentaatiossa ja muissa tiedoissa sekä erityisesti niiden oikeellisuudesta, virheettömyydestä, kolmansien osapuolten omistusoikeuksista ja tekijänoikeuksista, ajan tasalla pysymisestä, täydellisyydestä ja/tai käyttötarkoitukseen soveltuvuudesta lukuun ottamatta tahallista vahingoittamisen tarkoitusta.

IFA sitoutuu pitämään verkkosivut vapaina viruksista, mutta kuitenkin ei voida varmistaa, että ohjelmisto ja sen mukana toimitettavat tiedot olisivat viruksista vapaita. Tämän vuoksi käyttäjää suositellaan ryhtymään sopiviin tietoturvan toimenpiteisiin ja käyttämään virustutkaa ennen ohjelmiston, dokumentaation ja muiden tietojen lataamista.

YHTEYS

Saksan sosiaalisen tapaturmavakuutuksen työterveyden ja työturvallisuuden laitos (IFA)
(Institute for Occupational Health and Safety of German Social Accident Insurance (IFA))
Osasto 5 (Tapaturmien ehkäisy/tuoteturvallisuus)
Osoite: Alte Heerstr. 111, 53754 Sankt Augustin
Sähköposti: sistema@dguv.de
Verkkosivu: www.dguv.de/ifa (Webcode e20543)

Tarkastajan päivämäärä, allekirjoitus

Tekijän päivämäärä, allekirjoitus

APPENDIX 4 Order list (excluding Beckhoff)

Enclosure IP66 PC transparent cover 378x558mmx180	Fibox PC 563818T
Mounting plate	Fibox EKUVT
Power supply 48VDC 20A	MEAN WELL SDR-960-48
Power supply 24VDC 5A	MEAN WELL SDR-120-24
Joint box w. din rail	Fibox PC B 65 G
Inductive proximity switch	SICK IME08-04NPOZW2K 6pcs.
Connector set for sensors	Harting Han-kit 10A
Connector set for milling motor	Harting Han kit 3A
Safety-door switch	OMRON D4NS-4BF
Safety-door switch key	OMRON flat key
Filter/cover IP54 2kpl	ALFA ELECTRIC ALFA1000BPB
System fan 120mm 24VDC	SUNON EEC0382B1-000U-G99
USB A - connector IP68 panel mounting	AMPHENOL MUSBR-A511-40
USB cable 1,8m	ASSMANN AK-300114-018-S
HDMI - connector IP67 panel mounting	AMPHENOL MHDR-A111-30
DVI cable 1,8m	VCOM CG441-018-PB
RJ45 - connector IP68 panel mounting	AMPHENOL MRJR-5381-M1
Milling motor	KRESS 1050 FME-1, DE
Extra collet	Kress 3,175mm
Milling bit 6,5mm	Proxxon 80-225-54
V-milling bit 6,5mm	Proxxon 80-225-56
Milling bit 6,4mm	Proxxon 80-225-55
Carbide Cutter square tip 3,2 mm (9901)	Dremel 10-886-56
Carbide Cutter ball tip 3,2 mm (9905)	Dremel 10-886-58
Carbide Cutter spear tip 3,2 mm (9910)	Dremel 10-886-59